

INSTALLATION GUIDE



XT SERIES™ PANELS

MODEL XT30/XT50

XT SERIES™

INSTALLATION GUIDE

FCC NOTICE

This equipment has been tested and found to comply with the limits for a Class B digital device, pursuant to part 15 of the FCC Rules. These limits are designed to provide reasonable protection against harmful interference in a residential installation. This equipment generates, uses and can radiate radio frequency energy and, if not installed and used in accordance with the instructions, may cause harmful interference to radio communications. However, there is no guarantee that interference will not occur in a particular installation. If this equipment does cause harmful interference to radio or television reception, which can be determined by turning the equipment off and on, the user is encouraged to try to correct the interference by one or more of the following measures:

- Reorient or relocate the receiving antenna.
- Increase the separation between the equipment and receiver.
- Connect the equipment into an outlet on a circuit different from that to which the receiver is connected.
- Consult the dealer or an experienced radio/TV technician for help.

Changes or modifications not expressly approved by the party responsible for compliance could void the user's authority to operate the equipment.

This device has been designed to operate with the 1100 Series antenna listed in the Accessory Devices section, and having a maximum gain of 1.8 dB. Antennas not included in this list or having a gain greater than 1.8 dB are strictly prohibited for use with this device. The required antenna impedance is 50 ohms.

If necessary, the installer should consult the dealer or an experienced radio/television technician for additional suggestions. The installer may find the following booklet, prepared by the Federal Communications Commission, helpful:

“How to identify and Resolve Radio-TV Interference Problems.”

This booklet is available from the U.S. Government Printing Office, Washington D.C. 20402
Stock No. 004-000-00345-4

© 2009 Digital Monitoring Products, Inc.

Information furnished by DMP is believed to be accurate and reliable.

This information is subject to change without notice.

Panel Specifications

1.1	Power Supply	1
1.2	Communication.....	1
1.3	Panel Zones.....	1
1.4	Keypads/Expansion	1
1.5	Number of Zones	1
1.6	Outputs.....	1
1.7	Enclosure Specifications	1

Introduction

2.1	System Configurations.....	2
2.2	Caution Notes.....	2
2.3	Compliance Instructions	2

System Components

3.1	Wiring Diagram.....	2
3.2	Lightning Protection	2
3.3	Accessory Devices.....	3
3.4	XT30/XT50 Wiring Diagram	4

Installation

4.1	Mounting the Enclosure.....	5
4.2	Mounting Keypads	5
4.3	Installation Specifications	6

Primary Power Supply

5.1	AC terminals 1 and 2.....	6
5.2	Transformer Types	6
5.3	Power LED	6

Secondary Power Supply

6.1	Battery Terminals 3 and 4.....	7
6.2	Earth Ground.....	7
6.3	Replacement Period	7
6.4	Discharge/Recharge	7
6.5	Battery Supervision.....	7
6.6	XT30/XT50 Power Requirements.....	7
6.7	XT30/XT50 Standby Battery Calculations ..	8

Bell Output

7.1	Terminals 5 and 6	9
-----	-------------------------	---

Keypad Data Bus

8.1	Description	9
8.2	Terminal 7 - RED.....	9
8.3	Terminal 8 - YELLOW	9
8.4	Terminal 9 - GREEN.....	9
8.5	Terminal 10 - BLACK	9
8.6	Keypad Bus LEDs.....	9
8.7	Programming Connection	9
8.8	Keypad Addressing.....	9
8.9	Overcurrent OVC LED.....	10

Smoke and Glassbreak Detector Output

9.1	Terminal 11	10
-----	-------------------	----

Burglary Zones

10.1	Description	10
10.2	Operational Parameters	10
10.3	Zone Response Time.....	11
10.4	Keyswitch Arming Zone	11

TABLE OF CONTENTS

Powered Zone for 2-Wire Smoke Detectors

- 11.1 Terminals 25 and 26.....11

Annunciator Outputs

- 12.1 Description12
- 12.2 Harness Wiring12
- 12.3 Model 860 Relay Module.....12

Telephone RJ Connector

- 13.1 Description13
- 13.2 FCC Registration13
- 13.3 Notification.....13

Ethernet Connector J1

- 14.1 Description14
- 14.2 Ethernet LEDs14

Reset Jumpers J16

- 15.1 Description14

Flash Load Jumper J18

- 16.1 Description14

Cellular Connections

- 17.1 Cellular15

On-Board 1100 Series Wireless Antenna Connection

- 18.1 Wireless Antenna15
- 18.2 LED Operation15

Listed Compliance Specifications

- 19.1 Introduction16
- 19.2 Bypass Reports.....16
- 19.3 Current Draw.....16
- 19.4 Battery Standby.....16
- 19.5 Auxiliary and Bell Current16
- 19.6 Cross Zoning16
- 19.7 Software Version.....16

Household Burglar-Alarm System Units

ANSI/UL 1023

- 20.1 Bell Cutoff16
- 20.2 Entry Delay16
- 20.3 Exit Delay.....16
- 20.4 Wireless External Contact16
- 20.5 Wireless Supervision Time16
- 20.6 Wireless Audible Annunciation16
- 20.7 Panel location16
- 20.8 Test Frequency16

Digital Burglar Alarm Communicator System Units

ANSI/UL 1635

- 21.1 Entry Delay16
- 21.2 Exit Delay.....16
- 21.3 Test Frequency16
- 21.4 Automatic Bell Test17

Central Station Burglar Alarm Units

ANSI/UL 1610

- 22.1 Central Station.....17
- 22.2 Remote Disarm.....17
- 22.3 Central Station.....17

TABLE OF CONTENTS

Household Fire Warning System

ANSI/UL 985 NFPA 72 Specifications

23.1	Bell Output Definition	17
23.2	Household System	17
23.3	Household Fire Warning	17
23.4	Wireless External Contact	17
23.5	Wireless Supervision Time	17
23.6	Wireless Fire Verification.....	17
23.7	Battery Standby	17
23.8	Alarm Verification.....	17
23.9	Model 860	17
23.10	Test Frequency	17

California State Fire Marshal Specifications

24.1	Bell Output Definition	17
------	------------------------------	----

False Alarm Reduction Programmable Options

ANSI/SIA CP-01-2007

25.1	Shipping Defaults and Recommended Programming	18
25.2	Call Waiting	19
25.3	Entry Delay	19
25.4	Local Bell	19
25.5	Minimum Installation Requirements.....	19

Troubleshooting

26.1	Troubleshooting Section	20
26.2	Common LCD Keypad Displays.....	20

Wiring Diagrams

27.1	Multiple Indicating Circuit Modules Installation	21
------	--	----

Revisions to this Document

Listings and Approvals

Panel Specifications

1.1 Power Supply

Transformer Input: Plug-in – 16.5 VAC 40 VA, Model 321
 Wire-in – 16.5 VAC 40 VA, Model 320

Standby Battery: 12 VDC 7.7 Ah (40 VA transformer charges up to 2 batteries)

Auxiliary Output: 12 VDC at 500mA

Bell Output: 12 VDC at 1.5 Amps

Smoke Detector Output: 12 VDC at 100mA

All circuits inherent power limited

Note: Please see the Listed Compliance Specifications section for certificated application requirements.

1.2 Communication

Built-in SDLC Digital Dialer communication to DMP Model SCS-1R Receivers

Built-in network communication to DMP Model SCS-1R Receivers

Built-in cellular communication to DMP Model SCS-1R Receivers

Built-in CID (Contact ID) dialer communication

1.3 Panel Zones

Nine 1k Ohm EOL burglary zones: zones 1 to 9

One 3.3k Ohm EOL Class B powered fire zone with reset capability: zone 10

1.4 Keypads/Expansion

You can connect up to five supervised alphanumeric keypads.

You can connect additional unsupervised keypads.

- Security Command™, Thinline™, Aqualite™, Clear Touch™, and Icon keypads

In addition, the following zone expanders can be added:

- One, four, eight and 16-zone expansion modules
- Single-zone PIR and glassbreak detectors

1.5 Number of Zones

- Onboard zones 1-10
- Eight keypad bus addresses with zones 11-14, 21-24, 31-34, 41-44, 51-54, 61-64, 71-74, and 81-84
- Zone numbers 31 to 34 and 41 to 44 can support 1100 Series Key Fobs or DMP wireless output modules
- XT50 has 20 additional onboard wireless zones numbered 80-99

1.6 Outputs

The XT30/XT50 panels provide four open collector outputs rated for 50mA each. A Model 300 Output Harness is required. The open collector outputs provide the ground connection for a positive voltage source.

1.7 Enclosure Specifications

The XT30/XT50 panel ships standard in a 340 enclosure with EOL resistors, battery leads, user's guide, and programming sheet. All enclosures are constructed using 20-gauge cold rolled steel.

Enclosure Model	Size	Color
340	12.5" W x 9.5" H x 2.75" D	Gray (G)
349	12.5" W x 11.25" H x 3.5" D	Gray (G)

Introduction

2.1 System Configurations

The panels can be programmed to operate as either an All/Perimeter system that provides one perimeter area and one interior area, or as a Home/Sleep/Away system that provides one perimeter, one interior, and one bedroom area. The bedroom area provides for any protection devices the user wants disarmed during their sleeping hours and armed in the Away mode. In addition, the XT30/XT50 can operate as a six area system.

2.2 Caution Notes

Throughout this guide you will see caution notes containing information you need to know when installing the panel. These cautions are indicated with a yield sign. Whenever you see a caution note, make sure you completely read and understand its information. Failing to follow the caution note can cause damage to the equipment or improper operation of one or more components in the system. See the example shown below.



Always ground the panel before applying power to any devices: The panel must be properly grounded before connecting any devices or applying power to the panel. Proper grounding protects against Electrostatic Discharge (ESD) that can damage system components.

Remove All Power From the Panel! Remove all AC and Battery power from the panel before installing or connecting any modules, cards, or wires to the panel.

2.3 Compliance Instructions

For applications that must conform to a local authorities installation standard or a National Recognized Testing Laboratory certificated system, please see the Listed Compliance Specifications section near the end of this guide for additional instructions.

System Components

3.1 Wiring Diagram

The system wiring diagram in Figure 1 shows some of the accessory devices you can connect for use in various applications. A description of each module follows.

3.2 Lightning Protection

Metal Oxide Varistors and Transient Voltage Suppressors help protect against voltage surges on input and output circuits. This transient protection provides additional resistance to electrical surges such as lightning. Additional surge protection is available by installing the DMP 370 or 370RJ Lightning Suppressors. The DMP 370 and 370RJ Lightning Suppressors have not been investigated by UL.

3.3 Accessory Devices

Zone and Output Expansion Modules	
710 Bus Splitter/Repeater	Increases keypad wiring distance to 2500 feet.
711 Single Point Zone Expander	Provides one Class B zone for burglary devices and non-powered fire devices.
714, 714-8, 714-16 Zone Expander	Provides Class B zones for burglary and non-powered fire devices.
712-8 Zone Expander	Provides 8 zones for burglary devices.
715, 715-8, 715-16 Zone Expander	Provides 12 VDC Class B powered zones for smoke detectors, glassbreak detectors, and other 2- or 4-wire devices.
860 Relay Output Module	Provides one relay and three relay sockets for expansion of up to four relays.
Interface Card	
734 Wiegand Interface Card	Provides arming, disarming, and codeless entry using access control readers.
DMP Two-Way Wireless Devices	
1100D/1100DH/1100DI Wireless Receiver	Supports transmitters in residential or commercial wireless operation on the keypad bus. Only needed for XT30.
1100R Repeater	Provides additional range for wireless devices.
1101 Universal Transmitter	Provides both internal and external contacts that may be used at the same time to yield two individual reporting zones from one wireless transmitter.
1102 Universal Transmitter	Provides one external contact.
*1114 Four-Zone Expander	Provides four wireless zones with EOL resistors.
*1116 Relay Output	Provides one Form C relay.
*1117 LED Annunciator	Provides a visual system status indicator.
*1121 PIR Motion Detector	Provides motion detection with pet immunity.
1125 PIR Motion Detector	Provides multiple lens configurations, dual coverage area selection, and sensitivity adjustments.
*1126C/*1126R/*1126W PIR Motion Detector	Ceiling mount motion detector with panel programmable sensitivity and Disarm/Disable functionality.
1127C/1127W PIR Motion Detector	Wall mount motion detector with panel programmable sensitivity and Disarm/Disable functionality.
*1129 Glassbreak Detector	Detects the shattering of framed glass mounted in an outside wall and provides full-pattern coverage and false-alarm immunity.
*1131 Recessed Contact	Provides concealed protection for doors, windows or other applications.
*1139 Bill Trap	Provides a silent alarm option for retail and banking cash drawers.
1142BC Two-button Panic Belt Clip Transmitter	Provides portable two-button panic operation.
1142 Two-button Panic Transmitter	Provides permanently mounted under-the-counter two-button panic operation.
*1145 (Four-Button) *1146 (Two-Button) *1147 (One-Button)	Key Fob transmitters designed to clip onto a key ring or lanyard.
1161 Residential Smoke Detector	Residential smoke detector with sounder.
1162 Residential Smoke Detector	Residential smoke/heat detector with sounder and fixed rate-of-rise heat detector
Keypads	
*ePAD™ Virtual Keypads	Allows users to control the security system from any computer in the world using the Internet.
LCD keypads	Allows you to control the panel from various remote locations. Connect up to five keypads. Model 690, 790, 693/793 Security Command™ keypads, 7060, 7063, 7070, 7073, 7160, 7163, 7170, 7173 Thinline™ keypads, 7060A, 7063A, 7070A, 7073A Aqualite™ keypads, 7360, 7363 Thinline Icon Series keypads, or 7760 Clear Touch™ keypad to the keypad bus using terminals 7, 8, 9, and 10.
* These devices have not been investigated and shall not be used in listed installations	

3.4 XT30/XT50 Wiring Diagram

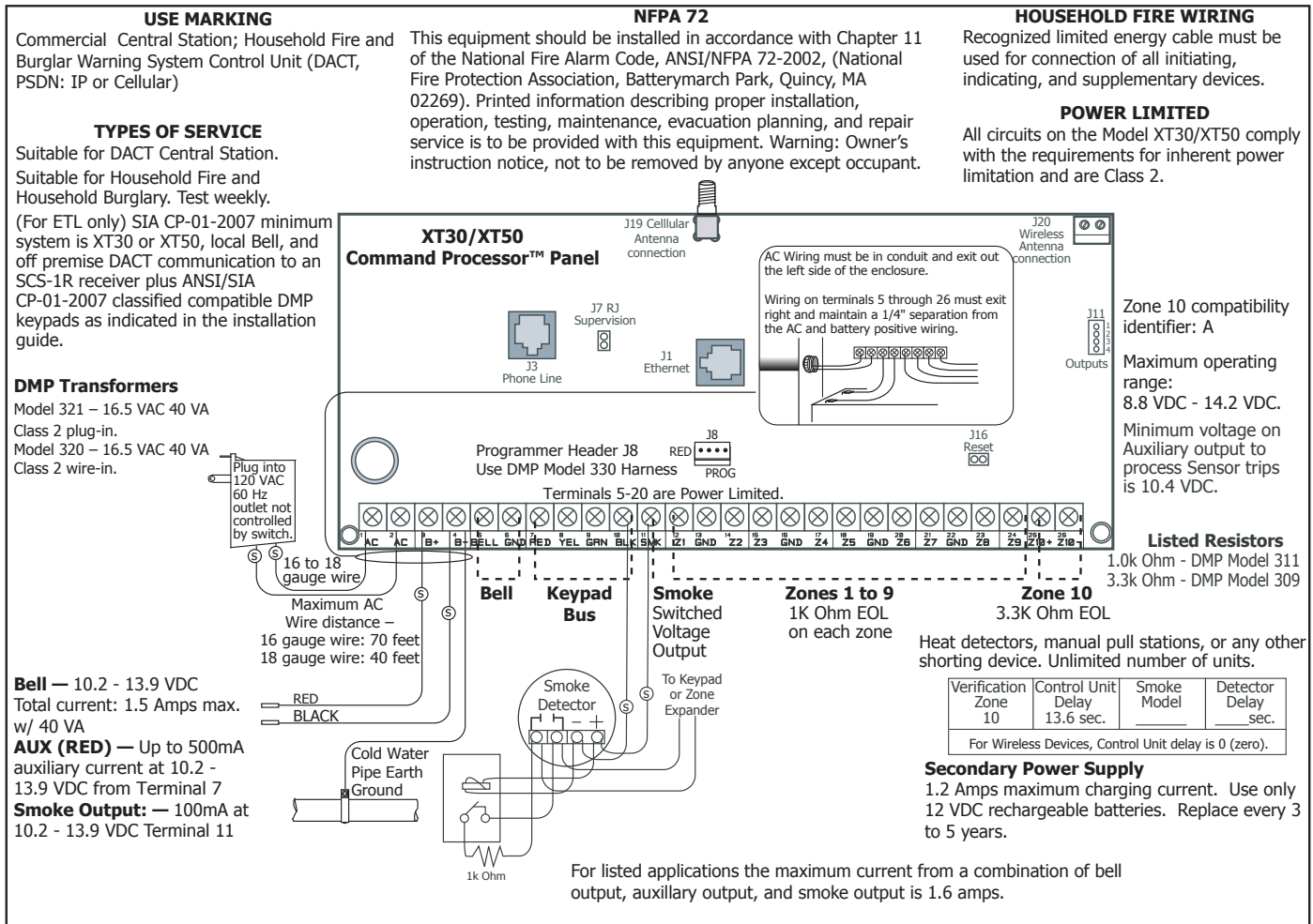

Figure 1: System Wiring Diagram

Installation

4.1 Mounting the Enclosure

The metal enclosure must be mounted in a secure, dry place to protect the panel from damage due to tampering or the elements. It is not necessary to remove the PCB when installing the enclosure. The PCB may be installed in the standard 340 small enclosure or in the optional 349 medium enclosure.

The 350A Attack Resistant enclosure is factory shipped with one knockout on the top left of the enclosure. As needed, additional knockouts or antenna exits may be added at the time of installation. See Figure 2 for the positions on the enclosure that can be added. Each additional knockout must be filled with conduit.

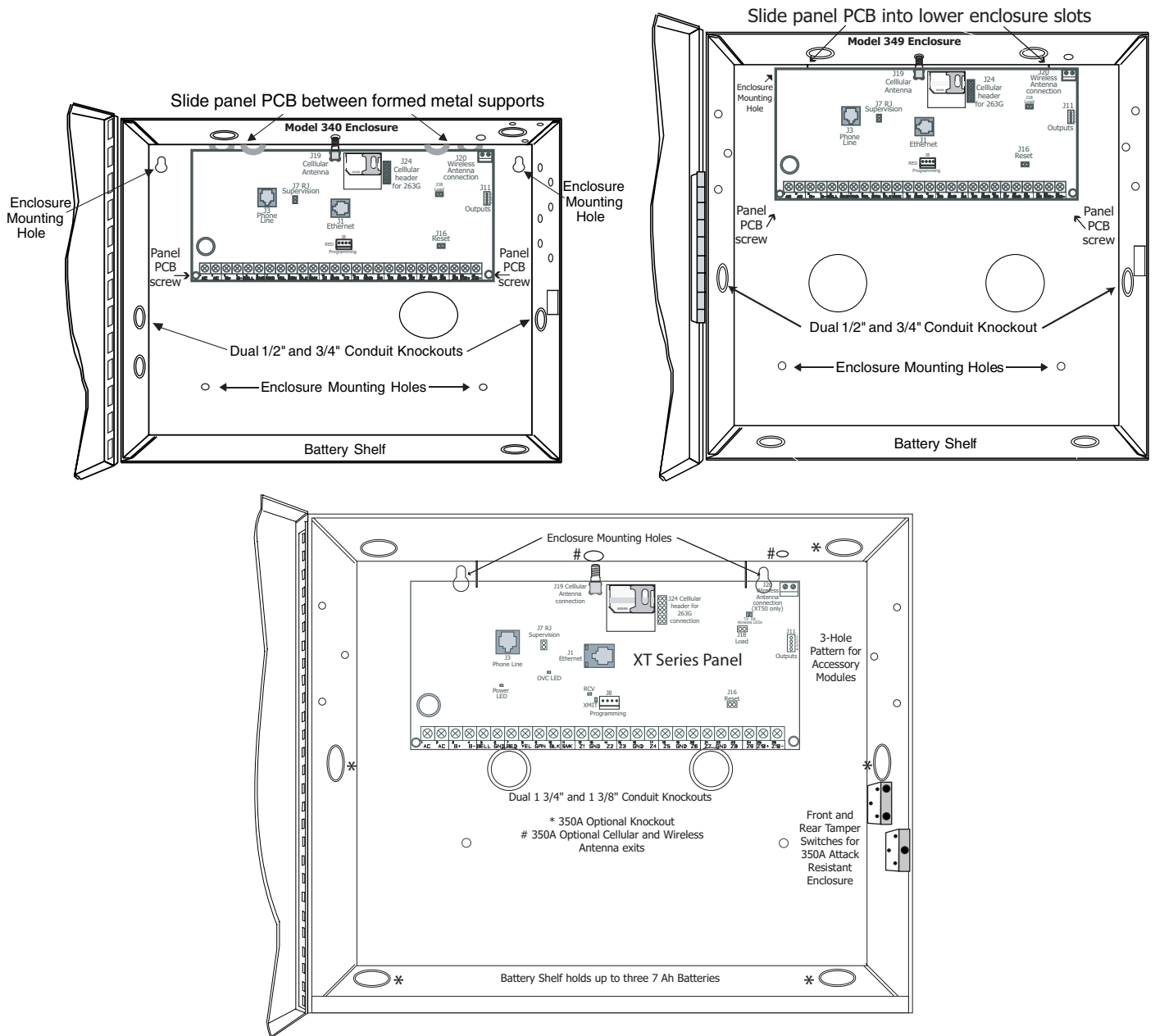

Figure 2: Standard 340 Enclosure (upper left), Optional 349 Enclosure (upper right), Optional 350A Enclosure (bottom)

4.2 Mounting Keypads

DMP keypads have removable covers that allow the base to be mounted on a wall or other flat surface using the screw holes provided on each corner.

For mounting keypads on solid walls, or for applications where conduit is required, use a DMP 695 or 696 keypad conduit backbox.

4.3 Installation Specifications

Several factors determine the performance characteristics of the keypad bus: the length of wire used, the number of devices connected, and the voltage at each device. When planning a keypad bus installation, keep in mind the following four specifications:

1. DMP recommends using 18 or 22-gauge **unshielded** wire for all keypad circuits. **Do not** use twisted pair or shielded wire for keypad bus data circuits.
2. On keypad bus circuits, to maintain auxiliary power integrity when using 22-gauge wire do not exceed 500 feet. When using 18-gauge wire do not exceed 1,000 feet. To increase the wire length or to add devices, install an additional power supply.

Note: Each panel allows a specific number of supervised keypads. Add additional keypads in the unsupervised mode. Refer to the panel installation guide for the specific number of supervised keypads allowed.

3. Maximum distance for any one bus circuit (length of wire) is 2,500 feet regardless of the wire gauge. This distance can be in the form of one long wire run or multiple branches with all wiring totaling no more than 2,500 feet. As wire distance from the panel increases, DC voltage on the wire decreases.



4. Maximum voltage drop between the panel (or auxiliary power supply) and any device is 2.0 VDC. If the voltage at any device is less than the required level, add an auxiliary power supply at the end of the circuit. When voltage is too low, the devices cannot operate properly.

For additional information refer to the 710 Installation Sheet (LT-0310) and or the LX-Bus/Keypad Bus Wiring Application Note (LT-2031).

Primary Power Supply

5.1 AC terminals 1 and 2

Connect the transformer wires to terminals 1 and 2 on the panel. Use no more than 70 ft. of 16 gauge, or 40 ft. of 18 gauge, wire between the transformer and the panel to deliver a minimum of 15.5 VAC when 500mA of current draw is used from the auxiliary power supply terminal 7.



Always ground the panel before applying power to any devices: The panel must be properly grounded before connecting any devices or applying power to the panel. Proper grounding protects against Electrostatic Discharge (ESD) that can damage system components. See Earth ground, in the Secondary Power Supply section.

5.2 Transformer Types

The transformer for the panel is 16.5 VAC 40 VA, which provides up to 1.5 Amps of bell output current, 500mA of auxiliary current, and 100mA of smoke detector output. You can use either the Model 320 wire-in or 321 plug-in transformer with the panel. The total current available is limited by the total battery standby requirements of the installation.



The transformer must be connected to a 120 VAC 60 Hz commercial power outlet that is not controlled by a wall switch. **Never share the transformer output with any other equipment.**

5.3 Power LED

When either AC transformer power or DC battery power is connected to the panel the PWR LED will show steady green.

Secondary Power Supply

6.1 Battery Terminals 3 and 4

Connect the black battery lead to the negative battery terminal. The negative terminal connects to the enclosure ground internally through the XT30 or XT50 circuit board. Connect the red battery lead to the positive battery terminal. Observe polarity when connecting the battery.

Add a second battery in parallel using the DMP Model 318 Dual Battery Harness. DMP requires each battery be separated by a PTC in the battery harness wiring to protect each battery from a reversal or short within the circuit. See Figure 3.



Use sealed lead-acid batteries only: Use 12 VDC sealed lead-acid rechargeable battery. Batteries supplied by DMP have been tested to ensure proper charging with DMP products.

GEL CELL BATTERIES CANNOT BE USED WITH THE XT30/XT50 PANEL.

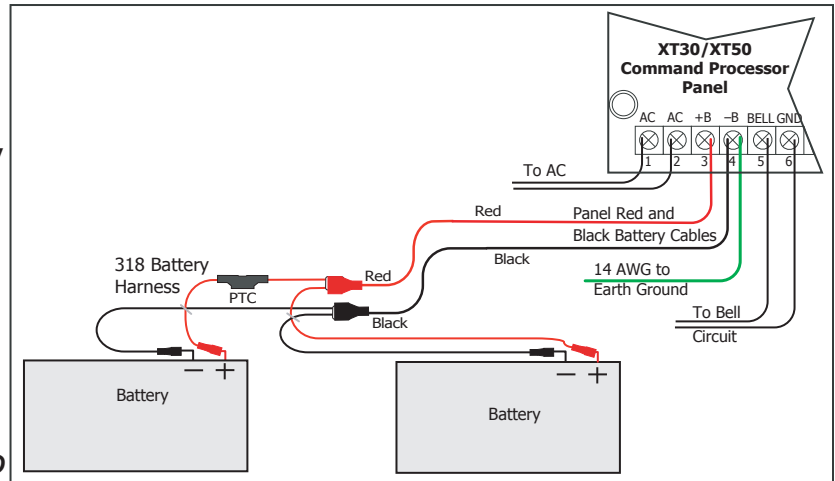

Figure 3: Wiring Multiple Batteries

6.2 Earth Ground

Terminal 4 of the panel must be connected to earth ground using 14 gauge or larger wire to provide proper transient suppression. DMP recommends connecting to a metal cold water pipe or ground rod only. Do not connect to electrical conduit or a telephone company ground.

6.3 Replacement Period

DMP recommends replacing the battery every 3 to 5 years under normal use.

6.4 Discharge/Recharge

The panel battery charging circuit float charges at 13.9 VDC at a maximum current of 1.2 Amps using a 40 VA transformer. The total current available is reduced by the combined auxiliary current draw from terminals 7, 11, and 25. The various battery voltage levels are listed below:

Battery Trouble:	Below	11.9 VDC
Battery Restored:	Above	12.6 VDC

6.5 Battery Supervision

The panel tests the battery once every hour when AC power is present. This test occurs 15 minutes past each hour and lasts for five seconds. A load is placed on the battery and if its voltage falls below 11.9 VDC a low battery is detected. If AC power has failed, a low battery is detected any time the battery voltage falls below 11.9 VDC.

If a low battery is detected with AC power present, the test is repeated every two minutes until the battery charges above 12.6 VDC; the battery restored voltage. If a faulty battery is replaced with a fully charged battery, the restored battery will not be detected until the next two-minute test is done.

6.6 XT30/XT50 Power Requirements

During AC power failure, the panel and all auxiliary devices connected draw their power from the battery. All devices must be taken into consideration when calculating the battery standby capacity. On the following page is a list of the power requirements of the panel. Add the additional current draw of DMP keypads, smoke detector output, and any other auxiliary devices used in the system for the total current required. The total is then multiplied by the total number of standby hours required to arrive at the total Ampere-hours required.

INSTALLATION

6.7 XT30/XT50 Standby Battery Calculations

Standby Battery Power Calculations		Alarm Current	
XT30 Panel	x 125mA _____ mA		125mA _____ mA
XT50 Panel	x 145mA _____		145mA _____
Built-in Network (additional current)	x 145mA _____		145mA _____
Built-in Cellular (additional current)	x 18mA _____		18mA _____
Active Zones 1-9	x 1.6mA _____	Qty _____ x	*2mA _____
Active Zone 10	x 4mA _____	Qty _____ x	30mA _____
2-Wire Smoke Detectors	0.1mA _____	Qty _____ x	0.1mA _____
Panel Bell Output		1500mA x	Max. _____
263G Digital Cellular Communicator	x 18mA _____	Qty _____ x	18mA _____
1100D Wireless Receiver	x 40mA _____	Qty _____ x	40mA _____
1100DH Wireless High Power Receiver	x 160mA _____	Qty _____	160mA _____
1100DI Wireless In-Line Receiver	x 30mA _____	Qty _____	30mA _____
690 Security Command Keypad	x 77mA _____	Qty _____ x	84mA _____
693 Security Command Keypad	x 92mA _____	Qty _____ x	120mA _____
790 Security Command Keypad	x 77mA _____	Qty _____ x	84mA _____
Active Zones (EOL Installed)	1.6mA _____	Qty _____ x	*2mA _____
793 Security Command Keypad	x 92mA _____	Qty _____ x	120mA _____
Active Zones (EOL Installed)	1.6mA _____	Qty _____ x	*2mA _____
7060/7160 Thinline/7060A Aqualite Keypad	x 72mA _____	Qty _____ x	87mA _____
7063/7163 Thinline/7063A Aqualite Keypad	x 85mA _____	Qty _____ x	100mA _____
7360 Thinline Icon Keypad	x 60mA _____	Qty _____ x	67mA _____
7363 Thinline Icon Keypad	x 73mA _____	Qty _____ x	80mA _____
7070/7170 Thinline/7070A Aqualite Keypad	x 72mA _____	Qty _____ x	87mA _____
Active Zones (EOL Installed)	1.6mA _____	Qty _____ x	*2mA _____
7073/7173 Thinline/7073A Aqualite Keypad	x 85mA _____	Qty _____ x	100mA _____
Active Zones (EOL Installed)	1.6mA _____	Qty _____ x	*2mA _____
734 Wiegand Interface Module	x 15mA _____	Qty _____ x	15mA _____
Active Zones (EOL Installed)	x 1.6mA _____	Qty _____ x	*2mA _____
738A Ademco Wireless Interface Module	x 75mA _____	Qty _____ x	75mA _____
708 Bus Extender Module (one pair)	x 20mA _____	Qty _____ x	20mA _____
710 Bus Splitter/Repeater Module	x 30mA _____	Qty _____ x	30mA _____
714 Zone Expansion Modules	x 7mA _____	Qty _____ x	7mA _____
Active Zones (EOL Installed)	x 1.6mA _____	Qty _____ x	*2mA _____
712-8 Zone Expansion Module	x 17mA _____	Qty _____ x	17mA _____
Active Zones (EOL Installed)	x 1.6mA _____	Qty _____ x	*2mA _____
714-8, 714-16 Zone Expansion Module	x 20mA _____	Qty _____ x	20mA _____
Active Zones (EOL Installed)	x 1.6mA _____	Qty _____ x	*2mA _____
715 Zone Expansion Module	x 7mA _____	Qty _____ x	7mA _____
Active Zones (EOL Installed)	x 4mA _____	Qty _____ x	*30mA _____
2-Wire Smokes	x .1mA _____	Qty _____ x	.1mA _____
715-8, 715-16 Zone Expansion Modules	x 20mA _____	Qty _____ x	20mA _____
Active Zones (EOL Installed)	4mA _____		*30mA _____
2-Wire Smokes	.1mA _____		.1mA _____
Aux. Powered Devices on Terminals 7 and 11 Other than Keypads and Modules	_____ mA		_____ mA
Total Standby _____ mA		Total Alarm _____ mA	
Total Standby _____ mA x number of Standby Hours _____ = _____ mA-hours			
needed _____ mA _____ mA-hours			
Total Alarm + _____ mA-hours			
		Total X .001	
* Based on 10% of active zones in alarm condition.		= _____ Amp-hrs Required	

Bell Output

7.1 Terminals 5 and 6

Nominal 12 VDC is supplied by terminal 5 on the panel to power alarm bells or horns. The output is rated for a maximum of 1.5 Amps with a 40 VA transformer. This output can be steady, pulsed, or Temporal Code 3 depending upon the Bell Action specified in Output Options programming. Terminal 6 is the ground reference for the bell circuit. If using a horn or siren, a 1k Ohm resistor should be added across the bell circuit for supervision.

Keypad Data Bus

8.1 Description

Terminals 7, 8, 9, and 10 of the panel are designated as the keypad data bus. In addition to keypads, the XT30/XT50 allows the connection of any combination of zone expansion modules, 5845LX Glassbreak Detectors, and 6155LX PIRs to the keypad bus up to the maximum of five devices.

8.2 Terminal 7 - RED

Nominal 12 VDC is supplied at terminal 7 to power keypads and zone expanders. This is also where power for any auxiliary device is supplied. The ground reference for terminal 7 is terminal 10. The maximum output is rated at 500mA. All auxiliary devices totaled together must not exceed the Terminal 7 maximum current rating of 500mA.

8.3 Terminal 8 - YELLOW

Data receive from keypads and zone expanders.

8.4 Terminal 9 - GREEN

Data transmit to keypads and zone expanders.

8.5 Terminal 10 - BLACK

Terminal 10 is the ground reference for LCD keypads, zone expanders, and any auxiliary devices being powered by terminals 7 and 11.

8.6 Keypad Bus LEDs

The two LEDs located just above terminal 13 indicate keypad transmit data (XMIT) and keypad receive data (RCV). The bottom LED flashes green to indicate data being transmitted from the panel. The top LED flashes yellow to indicate data being received by the panel from keypads, zone expanders, etc.

8.7 Programming Connection

A locking 4-pin header (J8) is provided to connect a keypad when using a DMP Model 330 Programming Cable. This provides a quick and easy connection for programming the panel.

8.8 Keypad Addressing

Keypad Bus expansion zones are numbered in groups of four corresponding to the address. Example: address 1 is zones 11-14 and address 5 is zones 51-54. There are a maximum of 32 zones possible on the Keypad Bus. All keypad zones terminate with a 1k Ohm EOL resistor.

Address	XT30/XT50 Zone Number
1	11-14
2	21-24
3	31-34
4	41-44
5	51-54
6	61-64
7	71-74
8	81-84

8.9 Overcurrent OVC LED

The Overcurrent LED (OVC) lights Red when the devices connected to the Keypad Bus draw more current than the auxiliary output rating. The OVC LED is located above terminals 9 and 10 as shown in Figure 4. When the OVC LED lights Red, the Keypad bus/auxiliary power (terminal 7) and the Programming header (J8) shut down.

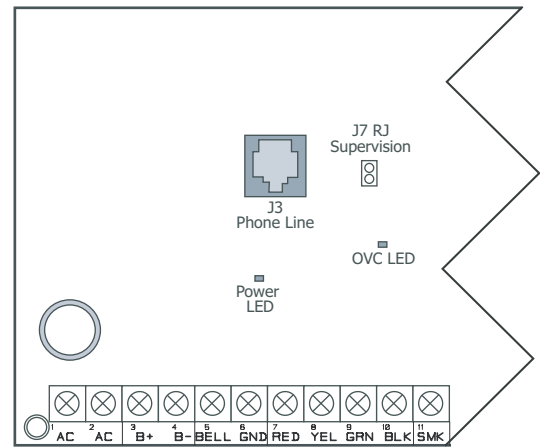

Figure 4: OVC LED location

Smoke and Glassbreak Detector Output

9.1 Terminal 11

Nominal 12 VDC at 100mA maximum (shared by terminal 25) is supplied at terminal 11 to power 4-wire smoke detectors or other auxiliary powered devices. This output can be turned off by the user for 5 seconds using the Sensor Reset option in the User Menu. Terminal 10 is the ground reference for terminal 11.

Burglary Zones

10.1 Description

On XT30/XT50 panels, terminals 12 to 24 are the nine burglary zones. For programming purposes, the zone numbers are 1 to 9. The zone configurations on terminals 12 to 24 are described below.

Terminal	Function	Terminal	Function
12	Zone 1 voltage sensing	19	Ground for zones 5 & 6
13	Ground for zones 1 & 2	20	Zone 6 voltage sensing
14	Zone 2 voltage sensing	21	Zone 7 voltage sensing
15	Zone 3 voltage sensing	22	Ground for zones 7, 8, & 9
16	Ground for zones 3 & 4	23	Zone 8 voltage sensing
17	Zone 4 voltage sensing	24	Zone 9 voltage sensing
18	Zone 5 voltage sensing		

The voltage sensing terminal measures the voltage across the 1k Ohm End-of-Line resistor and the zone's ground terminal. Dry contact sensing devices can be used in series (normally-closed) or in parallel (normally-open) with any of the burglary protection zones.

10.2 Operational Parameters

Each burglary protection zone detects three conditions: open, normal, and short.

The parameters for each are listed below:

Condition	Resistance on zone	Voltage on zone terminal
Open	over 1300 ohms	over 2.0 VDC
Normal	600 to 1300 ohms	1.2 to 2.0 VDC
Short	under 600 ohms	under 1.2 VDC

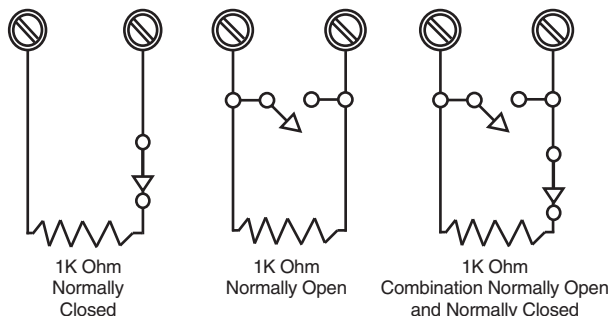

Figure 5: Protection Zone Contact Wiring

10.3 Zone Response Time

A condition must be present on a zone for 500 milliseconds before it is detected by the panel. Ensure detection devices used on the protection zones are rated for use with this delay.

10.4 Keyswitch Arming Zone

You can use a momentary keyswitch on a zone programmed as an Arming type for use in arming and disarming the system without a code.

Powered Zone for 2-Wire Smoke Detectors

11.1 Terminals 25 and 26

A resettable 2-wire Class B powered zone is provided on terminals 25 (positive) and 26 (negative) of the panel. For programming purposes, the zone number is 10 on the XT30/XT50. The zone uses a Model 309, 3.3k Ohm EOL resistor (provided with the panel) and has an operating range of 8.8 to 13.9 VDC.

The compatibility identifier is: B



Caution: Sensor reset on zone 10 will drop power to devices on this zone, causing the panel to sense an open condition on all zone types other than Fire, Fire Verify, and Supervisory. Whenever non-Fire and non-Supervisory zone types are used on zone 10, make the appropriate adjustments to the zone's Armed Action to prevent false alarms from occurring.

Manufacturer	Model	Detector ID	Base	Base ID	# of Detectors	Zone Expansion Modules
DMP/Hochiki	SLR-835B	HD-6			7	715, 715-8, 715-16, 725
Sentrol/ESL	429AT, 521B, 521BXT	S09A			12	715, 715-8, 715-16

Annunciator Outputs

12.1 Description

The four annunciator outputs can be programmed to indicate the activity of the panel's zones or conditions occurring on the system. Annunciator outputs do not provide a voltage but instead switch-to-ground voltage from another source. The outputs can respond to any of the conditions listed below:

- 1) Activation by zone condition: Steady, Pulse, Momentary, or Follower
- 2) Manually from the keypad
- 3) Communication failure
- 4) Armed area annunciation
- 5) Fire Alarm or Fire Trouble
- 6) Ambush alarm
- 7) Exit and Entry timers
- 8) System Ready
- 9) Late to Close

12.2 Harness Wiring

The open collector outputs are accessible by installing the DMP 300 Harness on the 4-pin header labeled J11. The output locations are shown below.

Output	Color	Wire	Output	Color	Wire
1	Red	1	3	Green	3
2	Yellow	2	4	Black	4

12.3 Model 860 Relay Module

Connect a Model 860 Relay Module to the panel to provide relays for the annunciator outputs that can be used for electrical isolation between the alarm panel and other systems or for switching voltage to control various functions. The module includes one relay and provides three additional sockets for expansion of up to four relays. Power is supplied to the relay coils from the panel keypad bus. The 860 mounts inside the panel enclosure using the 3-hole mounting configuration. Plastic standoffs are provided with the module for ease of installation. A 4-wire harness is also provided that connects the Model 860 to the panel.

Relay Contact Rating: 1 Amp at 30 VDC

Telephone RJ Connector

13.1 Description

Connect the panel to the public telephone network by installing a DMP 356 RJ Cable between the panel's J3 connector and the RJ31X or RJ38X phone jack. **CAUTION** - To reduce the risk of fire, use only No. 26 AWG or larger telecommunication line cord, such as DMP Model 356 Series Phone Cords.

A two pin header labeled RJ SUP (J7) is provided to allow monitoring of the telephone cable connected between the panel and a RJ38X jack (pins 2 and 7 jumpered). Attach a DMP Model 306 Harness between J7 and any available zone. The J7 pins are connected via the telephone cable to the RJ38X jack pins 2 and 7. The RJ38X jack provides a jumper between pins 2 and 7 which completes the circuit. Program the zone as a Supervisory type (SV). When the telephone cable is removed, the keypad displays zone trouble and produces a steady tone.

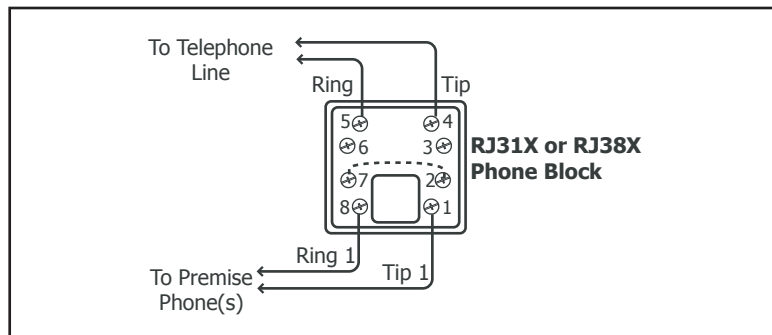

Figure 6: Phone Jack Wiring

13.2 FCC Registration

The panel complies with FCC part 68 and is registered with the FCC.

Registration number: CCKAL00BXT50

Ringer Equivalence: 0.0B

13.3 Notification

Registered terminal equipment must not be repaired by the user. In case of trouble, the device must be immediately unplugged from the telephone jack. The factory warranty provides for repairs. Registered terminal equipment may not be used on party lines or in connection with coin telephones. Notification must be given to the telephone company with the following information:

- a. The particular line(s) the service is connected to
- b. The FCC registration number
- c. The ringer equivalence
- d. The make, model, and serial number of the device

Ethernet Connector J1

14.1 Description

The Ethernet Connector (J1) is available on the Network version and connects directly to an Ethernet network using a standard patch cable.

14.2 Ethernet LEDs

The two LEDs, located on the left side of the J1 Ethernet Connector, indicate network operation. The top, Link LED is a steady green light when an ethernet cable is connected. The bottom, Activity LED flashes yellow to indicate messages are being received or transmitted.

Reset Jumpers J16

15.1 Description

The reset header is located just above the terminal strip on the right side of the circuit board and is used to reset the XT30/XT50 microprocessor. To reset the panel when first installing the system, install the reset jumper before applying power to the panel. After connecting the AC and battery, remove the reset jumper.

To reset the panel while the system is operational, for example, prior to reprogramming, install the reset jumper without powering down the system. Remove the reset jumper after one or two seconds.

After resetting the panel, begin programming within 30 minutes. If you wait longer than 30 minutes, you must reset the panel again.

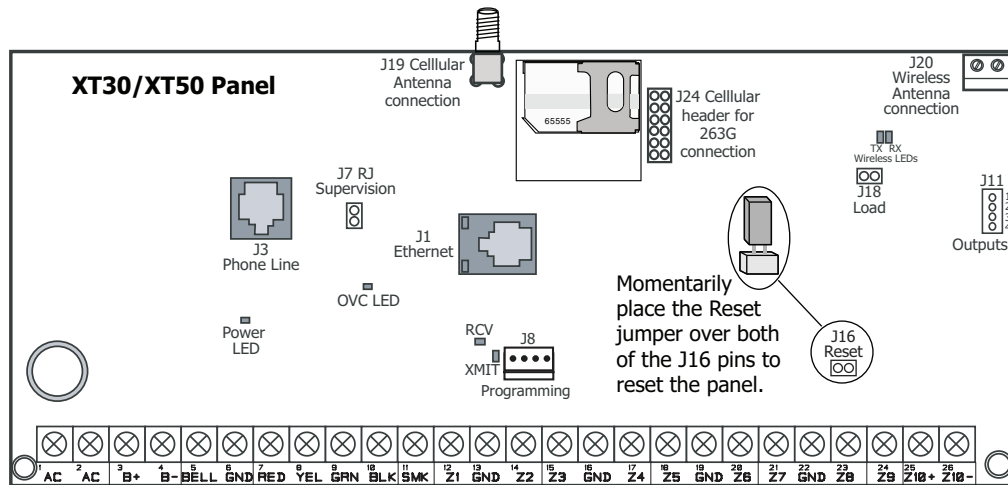

Figure 9: Panel Showing the Reset Jumper Wires

Flash Load Jumper J18

16.1 Description

The XT Series panel software can be updated via the panel's programming (PROG) header. To update the XT30/50 panel with a new software version, complete the following steps at the protected premise:

1. Place a jumper across the Reset (J16) header and then remove the yellow and green wires from keypad bus terminals 8 and 9.
2. Connect a DMP 399 Cable from the J8 Programming Header to the serial port of your PC operating Remote Link and containing the XT RU file. Requires Remote Link 1.43 or higher.
3. Start Remote Link and create or open the XT Series control panel account that matches the panel to be updated.
4. Set the Connection Information Type to Direct with a baud rate of 38400 and choose the appropriate COM port.
5. Select Panel>Remote Update, then select the correct RU file for the XT panel model.
6. While placing a short across the LOAD (J18) header, remove the jumper from the Reset (J16) header. Then remove the short from the LOAD header and click <Update> in Remote Link.
7. After the software version is updated, place the jumper across Reset (J16) then remove the 399 cable.
8. Replace the yellow and green wires to terminals 8 and 9.
9. Remove Reset (J16) jumper to resume normal panel operation.

Cellular Connections

17.1 Cellular

The XT30/XT50 Cellular option is available built-in at the factory or as an optional add-on module, Model 263G. The J19 SMA cellular antenna connector is provided for the built-in cellular version and protrudes through the top of the enclosure.

If the panel is not purchased with built-in cellular, then the J24 header is provided to connect a 263G Digital Cellular Communicator as an add-on. The 263G Digital Cellular Communicator provides a cellular antenna connection that protrudes through the top of the enclosure similar to J19.

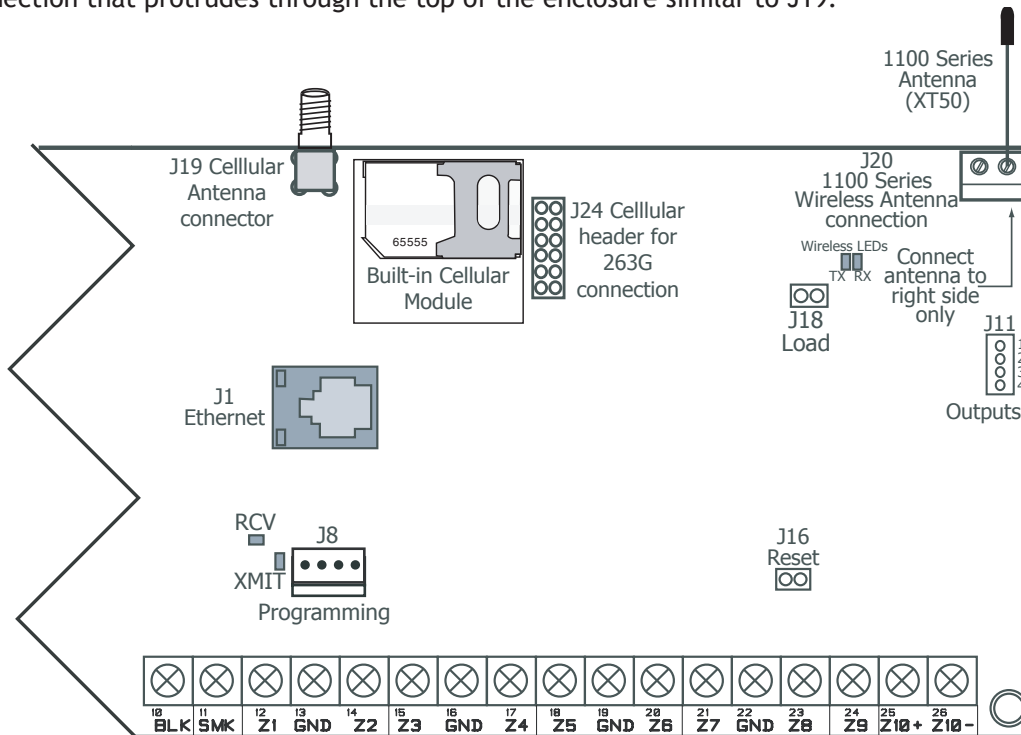

Figure 9: Cellular and 1100 Series Wireless Antenna Connections

On-Board 1100 Series Wireless Antenna Connection

18.1 Wireless Antenna

The XT50 Wireless Antenna terminal block J20 is located at the top right corner of the circuit board. The antenna installs through a small opening in the top of the enclosure and is attached to the panel using the right terminal. The left terminal is not used.

The XT50 built-in wireless operates with DMP 1100 Series transmitters. See section 3.4 for a list of accessory devices.

18.2 LED Operation

Green (TX): With a wireless house code enabled, the green LED flashes every time the receiver transmits (32 times per second). If a house code is not programmed in the panel, the panel is reset, or the panel is powered off, the green LED will be off. Under normal operation, the green LED flashes constantly with no interruption or change.

Yellow (RX): The yellow LED flashes every time the receiver hears a message from a programmed wireless transmitter. When a message is sent by a transmitter, typically by pressing or releasing the tamper switch, the yellow LED should flash indicating that the receiver received a message from the transmitter. If the LED never flashes, the transmitter is not getting through to the receiver. This could be because of a misprogrammed serial number or the transmitter is too far away. Under normal operation, the yellow LED will flash at every trip of every wireless transmitter and occasionally when the transmitters perform their periodic check-in. It is not unusual for this LED to stay off for many minutes at a time when no transmitters are communicating.

Listed Compliance Specifications

19.1 Introduction

The programming and installation specifications contained in this section must be completed when installing the XT30/XT50 in accordance with any of the ANSI/UL burglary standards. Additional specifications may be required by a particular standard.

19.2 Bypass Reports

The bypass reports must be programmed as YES for all listed burglary applications.

19.3 Current Draw

The total current draw from a combination of auxiliary, smoke, and bell output terminals must not exceed 1.6 Amps.

19.4 Battery Standby

For 24 Hour battery standby operation, use 9.0Ah batteries.

19.5 Auxiliary and Bell Current

For UL listed applications, the maximum auxiliary current is 400mA, and the maximum bell current is 500mA.

19.6 Cross Zoning

Each zone must have the capability of protecting the common area individually.

19.7 Software Version

For UL listed applications, the minimum software version must be Version 103.

Household Burglar-Alarm System Units ANSI/UL 1023

20.1 Bell Cutoff

The bell cutoff time cannot be less than four minutes.

20.2 Entry Delay

The maximum entry delay used must not be more than 45 seconds.

20.3 Exit Delay

The maximum exit delay used must not be more than 60 seconds.

20.4 Wireless External Contact

When used, the External Contact of 1101 or 1102 must be programmed Normally Closed.

20.5 Wireless Supervision Time

The Zone Information Supervision Time cannot be set to 0 (zero).

20.6 Wireless Audible Annunciation

The Wireless Audible option must be selected as DAY for residential applications.

20.7 Panel location

Mount panel inside protected area.

20.8 Test Frequency

The Test Frequency option must be programmed to send a report at least once every 30 days.

Digital Burglar Alarm Communicator System Units ANSI/UL 1635

21.1 Entry Delay

The maximum entry delay used must not be more than 60 seconds.

21.2 Exit Delay

The maximum exit delay used must not be more than 60 seconds.

21.3 Test Frequency

The Test Frequency option must be programmed to send a report once every 24 hours.

21.4 Automatic Bell Test

This option must be programmed as YES.

**Central Station Burglar Alarm Units
ANSI/UL 1610****22.1 Central Station**

Digital Dialer Central Station (DACT) service for commercial application can be provided by adding a listed local audible signal appliance and placing the XT30 or XT50 panel into the Model 350A Attack Resistant Enclosure.

22.2 Remote Disarm

REMOTE DISARM must be programmed as NO.

22.3 Central Station

MESSAGE TO TRANSMIT programming for zones must not be set to LOCAL (L).

**Household Fire Warning System
ANSI/UL 985 NFPA 72 Specifications****23.1 Bell Output Definition**

The bell output of the Model XT30/XT50 must be programmed to operate steady on burglary alarms and temporal on fire alarms. See the XT30/XT50 Programming Guide.

23.2 Household System

An alarm sounding device must be installed indoors so that it is clearly heard in all sleeping areas.

23.3 Household Fire Warning

Recognized limited energy cable must be used for connection of all initiating, indicating, and supplementary devices.

23.4 Wireless External Contact

When used, the External Contact of 1101 or 1102 must be programmed Normally Closed. See the XT30/XT50 Programming Guide.

23.5 Wireless Supervision Time

The Zone Information Supervision Time must be 3 minutes for fire devices. See the XT30/XT50 Programming Guide.

23.6 Wireless Fire Verification

When used, the Model 1161 and 1162 wireless smoke detectors must not be programmed as Fire Verification (FV) zone type. See the XT30/XT50 Programming Guide.

23.7 Battery Standby

For UL listed applications, the panel must have 24 Hour battery standby operation.

23.8 Alarm Verification

Alarm Verification must only be enabled on smoke detectors that do not employ an integral alarm verification feature.

23.9 Model 860

When using the Model 860 Relay Output, a fire and non-fire device must not share a relay.

23.10 Test Frequency

The Test Frequency option must be programmed to send a report at least once every 30 days.

California State Fire Marshal Specifications**24.1 Bell Output Definition**

The bell output of the Model XT30/XT50 must be programmed to operate steady on burglary alarms and temporal on fire alarms.

False Alarm Reduction Programmable Options ANSI/SIA CP-01-2007

25.1 Shipping Defaults and Recommended Programming

SIA CP-01 FEATURE PARAGRAPH # AND DESCRIPTION	DMP PROGRAMMING GUIDE LT-0981 SECTION #	REQUIREMENT	RANGE	SHIPPING DEFAULT	RECOMMENDED PROGRAMMING*
4.2.2.1 Exit Time	8.6 Exit Delay	Required (Programmable)	45 sec. - 250 sec.	60 Seconds	60 Seconds
4.2.2.2 Progress Annunciation	13.14 Prewarn Address	Allowed	Individual keypads may be disabled per zone	All keypads enabled	All keypads enabled
4.2.2.3 Exit Time Restart	8.6 Exit Delay	Required Option	For re-entry during exit time	Enabled	Enabled
4.2.2.5 Auto Stay Arm on Unvacated Premises	8.17 Occupied Premise - See Install Guide	Required Option (except for remote arming)	Occupied Premise NO/YES option	Enabled	Enabled Yes for Residential Applications
4.2.4.4 Exit Time and Progress Annunciation/ Disable - for Remote Arm	Not Available on Remote Arming	Allowed Option	Progress Annunciation Always disabled for Remote Arming	Not Available	Remote Arming not allowed for CP-01 installations.
4.2.3.1 Entry Delay(s)	8.5 Entry Delay	Required (Programmable)	30 sec. - 240 Sec. **	30 Seconds	At least 30 Seconds **
4.2.5.1 Abort Window - for Non-Fire Zones	3.3 Transmit Delay	Required Option	Disable by zone or zone type	Enabled NT DY EX Zone	Enabled
4.2.5.1 Abort Window Time - for Non-Fire Zones	3.3 Transmit Delay	Required (Programmable)	20 sec., 30 sec., or 40 sec. **	30 Seconds	At least 20 Seconds **
4.2.5.1.2 Abort Annunciation	3.3 Transmit Delay	Required Option	Annunciate that no alarm was transmitted	Yes	Yes
4.2.5.4.1 Cancel Annunciation	Always Enabled - Not Programmable	Required Option	Annunciate that a Cancel was transmitted (S49)	Always Enabled	Yes
4.2.6.1 & 4.2.6.2 Duress Feature	User Code + 1 = Ambush Code Not Available	Allowed Option	No 1 + derivative of another user code/no duplicates with other user codes	Code +1 Always Disabled	Not Programmable
4.3.1 Cross Zoning	13.16 Cross Zone	Required Option	Yes/No Zone Programming	No	Enabled using two or more programmed zones
4.3.1 Programmable Cross Zoning Time	8.7 Cross Zone Time	Allowed	4 sec. - 250 sec.	0 Seconds	Per walk path in protected premises
4.3.2 Swinger Shutdown	Not Available – Always On	Required	For all non-fire zones, shut down after 1 trip	Always On	Always On
4.3.2 Swinger Shutdown Disable	13.13 Swinger Bypass	Allowed	For non-police response zones	Yes	Enabled (all zones)
4.3.3 Fire Alarm Verification	13.5 Zone Type	Required Option	FV Type Zone	No	Yes as required (unless sensors can self verify)
4.5 Call Waiting Cancel	3.17 First Telephone Number	Required Option	Include *70P in Telephone Number	Disabled	Enabled if user has call waiting

* Programming at installation may be subordinate to other listed requirements for the intended application.

** For listed Installations, combined Entry Delay and Transmit Delay should not exceed 1 minute.

False Alarm Reduction Programmable Options ANSI/SIA CP-01-2007 (continued)

25.2 Call Waiting

The Call Waiting default setting is disabled. To cancel the Call Waiting feature, program * (star) 7 0 P (pause), the standard telephone code prefix that cancels call waiting, into the telephone number string. Cancel Call Waiting for telephone lines that have Call Waiting operational on the telephone line. See the XT30/XT50 Programming Guide.



Caution: A call waiting cancel programmed on a non-call waiting telephone line, would prevent communication to the central station.

25.3 Entry Delay

Only use Entry Delay 1. Do not use Entry Delay 2. See the XT30/XT50 Programming Guide.

25.4 Local Bell

All non-fire zones such as Night, Day, Exit, Aux1 and Aux 2 must be programmed for local bell enabled with a bell cutoff time set to a minimum of 6 minutes to provide a cancel window of 5 minutes or greater. This does not apply to manually operated zone types such as Panic and Emergency.

25.5 Minimum Installation Requirements

SIA CP-01-2007 minimum system installation requirements include an XT30 or XT50, a local Bell, and off premise DACT communication to an SCS-1R receiver plus one of the following compatible keypads.

- 690, 693, 790, 793 Security Command™ keypads
- 7060, 7063, 7070, 7073, 7160, 7163, 7170, or 7173 Thinline™ keypads
- 7060A, 7063A, 7070A, or 7073A Aqualite™ keypads
- 7360 or 7363 Thinline™ Icon keypads
- 7760 Clear Touch™ keypad

Troubleshooting

26.1 Troubleshooting Section

This section provides troubleshooting information for use when installing or servicing an XT30/XT50 system.

Problem	Possible Cause	Possible Solutions
Keypad displays "SYSTEM TROUBLE"	J16 Jumper is installed.	Remove the J16 reset jumper.
	Open or short on the green data wire to the keypad.	Check for broken or shorted wires between the panel and the keypad.
	Bad keypad or zone expander is affecting the Green data wire.	Replace keypad or zone expander.
Keypad keyboard is not functional. When a key is pressed, only a short beep is emitted.	Open or short on the yellow data wire to the keypad.	Check for broken or shorted wires between the panel and the keypad.
	Bad keypad or zone expander. is affecting the Yellow data wire.	Replace keypad or zone expander.
Keypad XMIT Green LED is off	Panel is reset.	Remove J16 jumper.
	Flash Load enabled.	Remove J18 jumper and reset panel.
Keypad RCV Yellow LED is off	Keypad/expanders are not connected to panel.	Connect keypad/expanders.
	Keypad/expanders are greater than five.	Check keypad/expanders address.
Keypad beeps when keys are pressed, but will not allow the user to arm or disarm, or enter the User Menu.	Two or more keypads are assigned to the same address.	Set each keypad on the system to a unique address.
Power LED is off.	AC/Battery is not connected.	Connect AC power and/or battery.
Overcurrent OVC LED turns Red	Too many devices attached to auxiliary.	Maximum current draw is 500 mA.
Wireless Green TX LED is off.	Wireless House Code is not programmed.	Program House Code in System Options.
Wireless Yellow RX LED never flashes.	Transmitters are not getting through to receiver.	Check transmitter serial numbers.
		Move transmitter closer.
		If XT30, replace 1100 series receiver.
Wireless Green TX and Yellow RX LEDs are both on steady	Panel is reset.	Remove J16 jumper.
	Flash Load enabled	Remove J18 jumper and reset panel.
Keypad operates intermittently, keystrokes may be missed, or display does not update consistently.	Wire length may exceed maximum, resulting in poor data performance.	Wire length can be reduced or a heavier gauge used.
		A power supply can be added near the keypad. See LT-2031, LX-Bus/Keypad Bus Wiring Application Note for more information.

26.2 Common LCD Keypad Displays

Listed below are several keypad messages you may see on the display. Follow the instructions in the Possible Solutions column to correct the problem.

Message	Meaning	Possible Solutions
INVALID CODE	The user code entered is not recognized by the system.	Check the user code and try again.
CLOSING TIME	The system was not armed at its scheduled closing time.	Users still on the premise should arm the system or extend the schedule to a later time.
AC TROUBLE	The system is not getting proper AC power.	Check that the AC connections are good from the transformer.
BATTERY TROUBLE	The battery is either low or missing.	Check to see that battery and connections are good.
SYSTEM BUSY	The system is performing another task with a higher priority or is being Remote Programmed.	Wait a few moments for the system to complete the task. Make sure the J16 jumper is not on the panel. If the message displays for several minutes, the keypad is not receiving polling from the panel.
TRANSMIT FAIL	The panel has attempted to communicate with the central station multiple times and has not succeeded.	Verify your communication type, account number, and phone number. Make sure the telephone line is connected and working properly.

Wiring Diagrams

27.1 Multiple Indicating Circuit Modules Installation

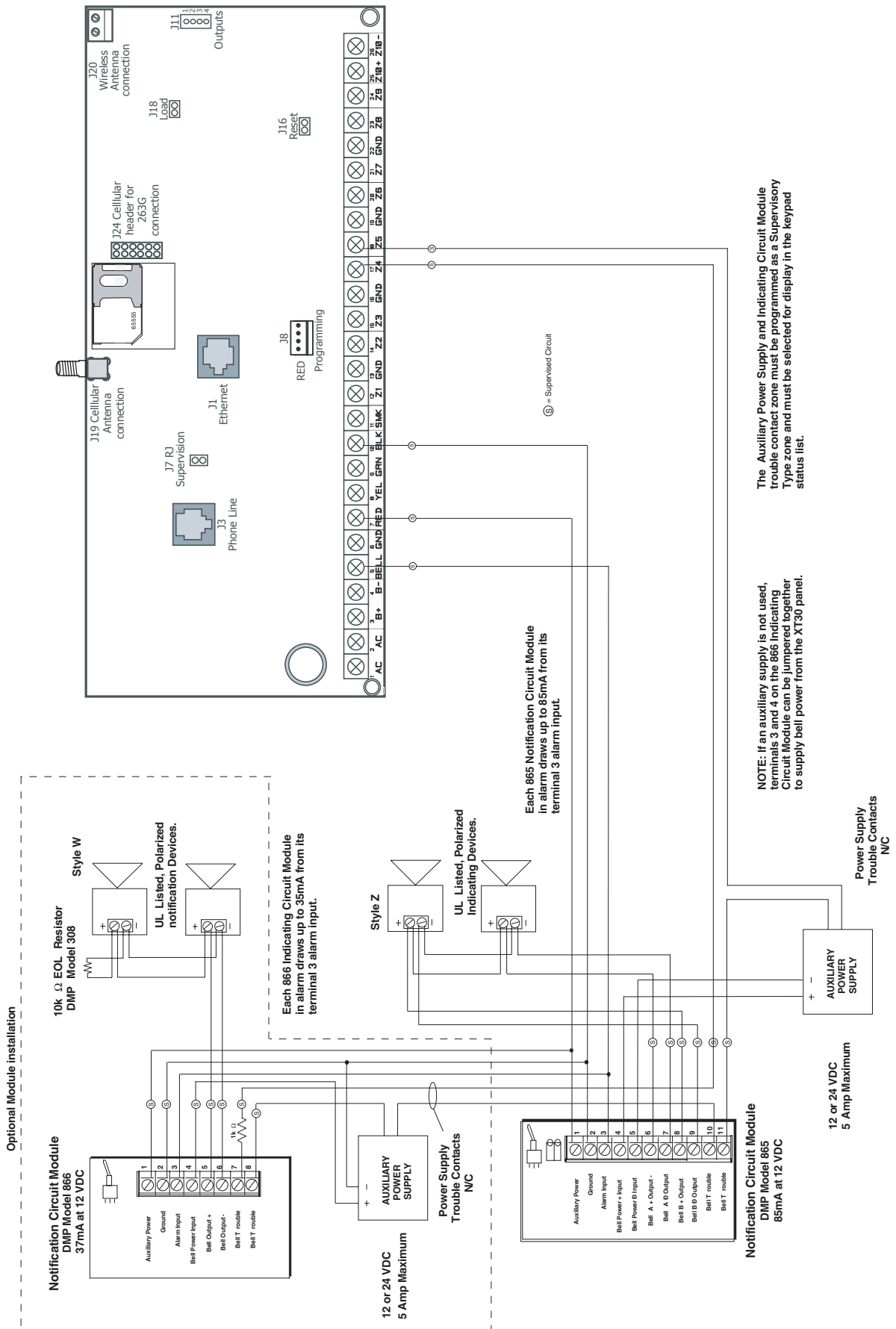

Revisions to This Document

This section explains the changes that were made to this document during this revision. This section lists the version, section number with heading, and a quick summary of the change.

Ver.	Section Number and Heading	Summary of Changes
1.02	1.5 Number of Zones	Updated to include addresses 6-8
	3.3 Accessory Devices	Added 1127C/1127W PIRs
	3.4 Wiring Diagram	Updated Use Marking text
	4.1 Mounting the Enclosure	Added 350A illustration
	8.8 Keypad Addressing	Updated to include addresses 6-8
	19.4 Battery Supervision	Added section for UL Listing requirements
	19.5 Auxiliary and Bell Current	Added section for UL Listing requirements
	19.6 Cross Zoning	Added section for UL Listing requirements
	19.7 Software Version	Added section for UL Listing requirements
	20.7 Panel Location	Removed reference to enclosure tamper
	20.8 Test Frequency	Added section for UL Listing requirements
	21.5 Central Station	Moved to section 22.1
	22.2 Remote Disarm	Added section for UL Listing requirements
	22.3 Central Station	Added section for UL Listing requirements
	22.7 Battery Standby	Added section for UL Listing requirements
	22.8 Alarm Verification	Added section for UL Listing requirements
	22.9 Model 860	Added section for UL Listing requirements
	22.10 Test Frequency	Added section for UL Listing requirements
	Listings and Approvals	Added UL Listings

This page intentionally left blank

Listings and Approvals

California State Fire Marshal (CSFM)

ETL: ANSI/SIA CP-01 False Alarm Reduction
ANSI/UL 1023 Household Burglar
ANSI/UL 985 Household Fire Warning
ANSI/UL 1635 Digital Burglar

FCC Part 15 ID: CCKPC0096

FCC Part 68 Registration ID CCKAL00BXT50

Industry Canada ID: 5251A-PC0096

Underwriters Laboratories (UL) Listed

ANSI/UL 1023 Household Burglar
ANSI/UL 985 Household Fire Warning
ANSI/UL 1635 Digital Burglar
ANSI/UL 1610 Central Station Burglar



Digital Monitoring Products

800-641-4282

www.dmp.com

Made in the USA

INTRUSION • FIRE • ACCESS • NETWORKS

2500 North Partnership Boulevard

Springfield, Missouri 65803-8877

LT-0980 1.02 © 2009 Digital Monitoring Products, Inc.

9505

