



Electrical Library

Elektrotechnische Bibliothek

Librairie électrique

Handbuch Elektrik

Libreria Impianto Elettrico

Biblioteca Eléctrica

Livraria Eléctrica

Defender





DEFENDER 2002 MY ELECTRICAL LIBRARY

LRL 0389ENG

Published by Land Rover

© Land Rover 2001

All rights reserved. No part of this publication may be reproduced, stored in a retrieval system or transmitted in any form, electronic, mechanical, recording or other means without prior written permission from Land Rover Group.

INTRODUCTION	1.1
ABOUT THIS DOCUMENT	1.1
ELECTRICAL PRECAUTIONS	1.3
ABBREVIATIONS	1.5
HOW TO USE THIS DOCUMENT	1.7
FAULT DIAGNOSIS	1.9
WIRE COLOUR CODES	1.10
FUSE DETAILS	2.1
UNDER SEAT FUSE BOX	2.2
PASSENGER COMPARTMENT FUSE BOX	2.4
EARTH POINTS AND HEADERS	3.1
DESCRIPTION AND OPERATION	4.1
ANTI-THEFT ALARM AND CENTRAL DOOR LOCKING (CDL)	4.1
ENGINE IMMOBILISATION	4.7
WINDOWS	4.11
HEATED SEATS	4.13
DIAGNOSTIC SOCKET	4.14
STARTING AND CHARGING – 300 Tdi	4.15
STARTING AND CHARGING – Td5	4.18
ANTI-LOCK BRAKING SYSTEM (ABS)	4.21
AIR CONDITIONING – 300 Tdi	4.25
AIR CONDITIONING – Td5	4.28
HEATER	4.31
HEATED REAR WINDOW	4.32
HEATED FRONT SCREEN	4.33
WIPERS AND WASHERS	4.34
BRAKE AND REVERSE LAMPS	4.37
HEAD, SIDE AND TAIL LAMPS	4.39
HEADLAMP LEVELLING	4.44
FOG LAMPS	4.46
DIRECTION INDICATOR/HAZARD WARNING LAMPS	4.48
INTERIOR LAMPS – NON ANTI-THEFT ALARM	4.51
INTERIOR LAMPS – ANTI-THEFT ALARM	4.53
INTERIOR ILLUMINATION	4.56
INSTRUMENTS	4.58
HORNS	4.64

CONTENTS

CLOCK	4.65
CIGAR LIGHTER	4.66
ACCESSORY SOCKETS	4.67
TRAILER SOCKET	4.68
AUDIO SYSTEM	4.69
FUEL PUMP	4.71
OVERSPEED WARNING	4.73
CONNECTOR	5.1
CONNECTOR REFERENCE NUMBERS	5.1

ABOUT THIS DOCUMENT

General

This document is intended to assist in diagnosing electrical faults, and should be used in conjunction with the Electrical Circuit Diagrams. The document is divided into the following sections.

1. **INTRODUCTION** – Includes Electrical Precautions, a list of Abbreviations and general information on how to use this document.
2. **FUSE DETAILS** – Provides details of location, rating in Amperes, and circuit(s) protected.
3. **EARTH POINTS AND HEADERS** – Provides details of earth points and earth headers, including a plan view of the vehicle to aid location.
4. **DESCRIPTION AND OPERATION** – Provides an explanation of how each of the systems operate.
5. **CIRCUIT REFERENCE NUMBERS** – Provides a list of circuit reference numbers against a model or feature to which they apply.
6. **CONNECTOR DETAIL** – Details of connectors including a location photograph, face view and pin-out table.

NOTE: Before starting electrical checks on the vehicle, ensure that relevant mechanical functions operate satisfactorily.

References

References to the LH or RH side given in this document are made when viewing the vehicle from the rear.

Operations covered in this document do not include reference to testing the vehicle after repair. It is essential that work is inspected and tested after completion and, if necessary, a road test of the vehicle is undertaken, particularly where safety related items are concerned.

CAUTION: Before undertaking any electrical work on a vehicle ALWAYS read the ELECTRICAL PRECAUTIONS.

INTRODUCTION

Battery Voltage

Open Circuit Voltage Test

Before commencing diagnosis of electrical problems, verify the condition of the battery is acceptable by using the open circuit voltage test.

1. Switch off all electrical loads on the vehicle.
2. Adjust digital multimeter to read dc volts on the appropriate scale.
3. Connect test probes across battery terminals ensuring that polarity is correct and record the voltage displayed.

A reading of 12.3 V or more is acceptable; any battery which reads less than this will need charging.

NOTE: If the vehicle has been used within a period of 8 hours prior to the test, surface charge must be removed from the battery by switching the headlamps on for approximately 30 seconds. Wait a further 60 seconds before checking the open circuit voltage.

Battery voltage is used as a known reference for ascertaining whether or not circuits are receiving sufficiently high voltage for components to function correctly. This reference is only a guide since most electronic circuits are designed to function over a wide range of voltages. In addition, consideration must be given to readings affected by voltage drop across certain components and fluctuations due to cable lengths.

ELECTRICAL PRECAUTIONS

General

The following guidelines are intended to ensure the safety of the operator whilst preventing damage to the electrical and electronic components fitted to the vehicle. Where necessary, specific precautions are detailed in the relevant sections of this document, reference of which should be made prior to commencing repair operations.

Equipment – Prior to commencing any test procedure on the vehicle, ensure that the relevant test equipment is working correctly and any harness or connections are in good condition. This particularly applies to mains lead or connections.

WARNING: Before commencing work on an ignition system, all high tension terminals, adaptors and diagnostic equipment for testing should be inspected to ensure that they are adequately insulated and shielded to prevent accidental personal contact and to minimise the risk of shock. Wearers of surgically implanted pacemaker devices should not work in close proximity to ignition circuits or diagnostic equipment.

Polarity – Never reverse connect the vehicle battery and always observe correct polarity when connecting test equipment.

High Voltage Circuits – Whenever disconnecting live ht circuits, always use insulated pliers and never allow the open end of the ht lead to come into contact with other components, particularly ECU's. Since high voltage spikes can occur on the terminals of the coil while the engine is running, exercise caution when measuring the voltage at these points.

Connectors and Harnesses – The engine compartment of a vehicle is a particularly hostile environment for electrical components and connectors. Always ensure these items are dry and oil free before disconnecting and connecting test equipment. Never force connectors apart either by using tools or by pulling on the wiring harness. Always ensure locking tabs are disengaged before removal and note orientation to enable correct reconnection. Ensure that any protective covers and substances are replaced if disturbed.

Before removing a faulty component, refer to the Workshop Manual for removal procedures. Ensure the ignition switch is turned to the 'OFF' position, the battery is disconnected (**see *Battery Disconnecting***) and any disconnected harnesses are supported to avoid any undue strain at the terminals. When replacing the component keep oily hands away from electrical connection areas and push connectors home until any locking tabs fully engage.

INTRODUCTION

Battery Disconnecting

Before disconnecting the battery, switch off all electrical equipment. If the radio is to be serviced, ensure the security code has been deactivated. When the battery is disconnected, certain data such as radio code and clock time will be lost.

CAUTION: To prevent damage to electrical components, ALWAYS disconnect the battery when working on the vehicle electrical systems. The earth lead must be disconnected first and reconnected last. Always ensure that battery leads are routed correctly and are not close to any potential chafing points.

Battery Charging

Recharge the battery out of the vehicle and keep the top well ventilated. While being charged or discharged, and for approximately fifteen minutes afterwards, batteries emit hydrogen gas. This gas is inflammable.

Always ensure any battery charging area is well ventilated and that every precaution is taken to avoid flames and sparks.

Disciplines

Switch off ignition prior to making any connection or disconnection in the system as electrical surge caused by disconnecting 'live' connections can damage electrical components.

Ensure hands and work surfaces are clean and free of grease, swarf, etc. as grease collects dirt which can cause tracking or high-resistance contacts.

When handling printed circuit boards, treat them as you would a disc – hold by the edges only; note that some electrical components are susceptible to body static.

Connectors should never be subjected to forced removal or refit, especially inter-board connectors. Damaged contacts will cause short-circuit and open-circuit conditions.

Prior to commencing testing, and periodically during testing, touch a good earth, i.e. cigar lighter socket, to discharge body static as some electrical components are vulnerable to static electricity.

Grease for Electrical Connectors

Some under bonnet and under body connectors are protected against corrosion by the application of a special grease during production. Should connectors of this type be disturbed, repaired, or replaced, a grease of this type, available under part number BAU 5811, should again be applied. Do not apply grease to any connectors that do not have grease applied as standard.

NOTE: The use of other greases must be avoided as they can migrate into relays, switches, etc. contaminating the contacts and leading to intermittent operation or failure.

ABBREVIATIONS

General

A	Ampere
ABS	Anti-lock braking system
ac	Alternating current
A/C	Air Conditioning
ATF	Automatic transmission fluid
BUS	Databus
CAN	Controller area network
Cav	Cavity
Cct	Circuit
CCU	Central control unit
CDL	Central door locking
CHMSL	Centre high mounted stop lamp
Col	Colour
dc	Direct current
DCU	Diagnostic control unit
EAT	Electronic automatic transmission
EBD	Electronic braking force distribution
ECM	Engine control module
ECT	Engine coolant temperature
ECU	Electronic control unit
EKA	Emergency key access
ETC	Electronic traction control
F	Fuse
FL	Fusible link
HDC	Hill descent control
HRW	Heated rear window
HT	High tension
ISO	International Organisation for Standardisation
LED	Light emitting diode
LH	Left hand
LHD	Left hand drive
MIL	Malfunction indicator lamp
NAS	North American specification
PWM	Pulse width modulated
R	Relay
RF	Radio frequency

INTRODUCTION

RH	Right hand
RHD	Right hand drive
SRS	Supplementary restraint system
V	Volt
VIN	Vehicle identification number
W	Watt

HOW TO USE THIS DOCUMENT

Fuse Details

Contains information on fuse functions and values and should be used together with the power distribution circuit diagrams to establish which systems share a common power supply and to ensure that correct value fuses are fitted.

Earth Points and Headers

Shows a plan view of the vehicle with location of all earth points. Supporting photographs and connector detail information appear in the Connector section.

Description and Operation

Presented in the same order as the circuit diagrams in the Electrical Circuit Diagram folder, each of the descriptions contains a brief overview of the main system functions and includes reference to the appropriate wire colours. Always read this section before starting work on a system so that a good understanding of system functionality is obtained.

Connector Details

This section is effectively an index of every electrical connector on the vehicle, including headers and eyelets. A page is dedicated to each connector, with the information presented in a standard format. The connector number is displayed on each page header to ease reference. Connector information comprises:

- **Connector Number** – The assigned number, prefixed 'C'.
- **Connector Name** – Usually derived from the component to which the connection is made.
- **Male/Female** – If applicable, identifies the gender of the connector pins (NOT the housing) as Male or Female. Generally, connectors mating directly into a component have Female pins.
- **Colour** – If applicable, the colour of the connector housing is shown. NATURAL is used to describe connectors with a clear/translucent plastic finish.
- **Location Statement** – Used in conjunction with the photograph to determine the location of the connector.
- **Photograph** – Shows the location of the subject connector. In most cases the photograph will indicate the amount of trim removal necessary to reveal the connector. For convenience some photographs identify more than one connector.
- **Face View** – An outline of the connector housing, viewed from the front, showing pin numbers (if applicable).
- **Pin-out Table** – A three column table, detailing the colour and position of each wire in the connector:

INTRODUCTION

Cav	Col	Cct
1	GR	ALL
2	B	ALL

1. **Cav:** The connector pin (cavity) number.
2. **Col:** The colour of wire populating the connector pin.
3. **Cct:** Identifies the model or feature which uses the wire. 'ALL' means applicable to all models in the range fitted with the feature or system in question. In instances where different models, features or systems require different colour wires to be fitted in a cavity, each instance of the cavity is included in the pin-out table.

NOTE: Wires may not be fitted to all cavities.

Example – 12 Pin Connector

Cav	Col	Cct
2	G	ALL
4	GW	8
4	GB	10
4	GR	12
5	LGB	ALL
6	GB	8
6	GW	10
6	GR	12
8	B	ALL

Where necessary, a table listing the circuit reference numbers against a description of the model or features which may or may not be fitted can be found at the beginning of the connector section. A sample of a typical table is shown below.

Cct	Model or Feature
1	3 Door
2	5 Door
3	LHD
4	RHD
5	Japanese vehicles only
6	NAS vehicles only
7	Australian vehicles only

FAULT DIAGNOSIS

General

When diagnosing an electrical fault, follow the steps below:

1. Read the circuit description appropriate to the reported fault to ensure a good understanding of circuit operation.
2. Study the power distribution, fuse details and earth distribution diagrams and identify other circuits which share fuses and/or earth points. Check whether these circuits operate correctly.
3. Using the photographs contained in the Connector section, locate a point on the circuit (approximately half way between supply and earth) which is easily accessible.
4. Check that the pin-out details of the connector are correct and that the correct signals exist at the correct terminals.
5. Using the marker pen supplied (or other suitable non-permanent marker pen), mark the parts of the circuit you have verified.
6. Continue to the next point on the circuit which is easiest to access and repeat the above.
7. Continue with this approach until a fault is found, rectify the fault and then verify that the circuit operates correctly.

CAUTION: Never probe directly into the front face of a connector. This can damage the terminal and cause a failure. Always probe the back of a terminal, taking care not to damage the terminal or any seals.

Never probe wire insulation. On small diameter cables this can cut the conductors. It may also allow moisture into the cable, causing corrosion.

INTRODUCTION

WIRE COLOUR CODES

General

The following list contains wire colour codes used on the vehicle harness's.

Code	Colour
B	Black
G	Green
K	Pink
LG	Light green
N	Brown
O	Orange
P	Purple
R	Red
S	Slate (Grey)
U	Blue
W	White
Y	Yellow

Introduction

Fuses are mounted in one of two fuse boxes. One fuse box is located under the RH front seat, and the other is located below the centre of the fascia.

The under seat fuse box contains three different types of fuse:

1. **Blade type fuse** – Small, pull out, male fuse, used to protect circuits from 5 A to 30 A.
2. **J-case fuse** – Square shaped, pull out, female fuse, used to protect circuits from 30 A to 60 A.
3. **Bolt down fuse** – Also known as a fusible link, used to protect circuits from 40 A to 250 A.

The passenger compartment fuse box contains blade type fuses only.

FUSE DETAILS

UNDER SEAT FUSE BOX

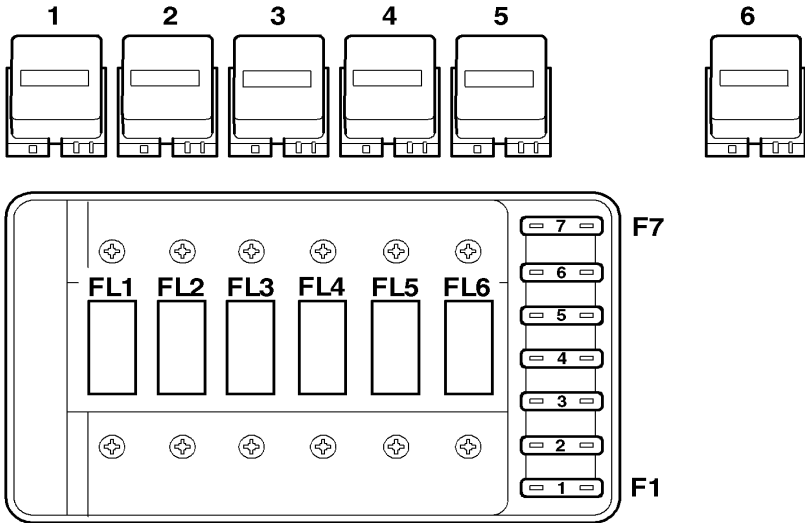

186 5673

1. Air Conditioning (A/C) relay
2. Air Conditioning (A/C) relay
3. Glow plug relay
4. Main Relay
5. Fuel pump relay
6. ABS return pump relay.

FUSE DETAILS

Link	Rating	Vehicle	Function
FL1	100 A	Td5	Glowplug relay, fusible links 2, 3, and 4, fuses 1, 2, and 3 of the under seat fuse box, fuse 36 of the passenger compartment fuse box.
FL1	100 A	300 Tdi	Glowplug relay, fusible links 2, 3, and 4, fuses 1, 2, and 3 of the under seat fuse box.
FL2	60 A	All	Fuses 28, 29, 30, 31, and 32 of the passenger compartment fuse box.
FL3	60 A	All	Ignition relay.
FL4	30 A	All	ABS return pump relay.
FL5	60 A	All	Ignition switch, starter motor relay.
FL6	30 A	All	Lighting switch.

Fuse	Rating	Vehicle	Function
F1	30 A	Td5	ABS ECU.
F1	30 A	300 Tdi	Not used.
F2	20 A	All	Accessory socket.
F3	30 A	All	Column switch.
F4	20 A	Td5	Fuel pump relay.
F4	20 A	300 Tdi	Not used.
F5	30 A	Td5	Main relay, inertia switch.
F5	30 A	300 Tdi	Not used.
F6	15 A	All	BBUS, alarm relay, anti-theft alarm ECU.
F7	20 A	All	Anti-theft alarm ECU.

FUSE DETAILS

PASSENGER COMPARTMENT FUSE BOX

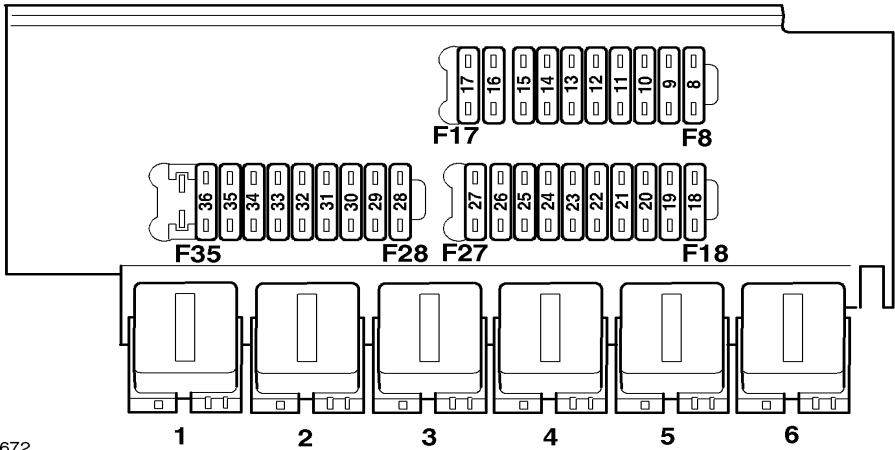

186 5672

1. Heated front screen relay
2. Starter motor relay
3. Heated rear window relay
4. Headlamp relay
5. Anti-theft alarm relay
6. Seat heat/window lift relay.

FUSE DETAILS

Fuse	Rating	Vehicle	Function
F8	10 A	All	Anti-theft alarm ECU, BBUS.
F9	15 A	All	Windscreen wiper delay ECU.
F10	10 A	All	Rear screen wiper relay.
F11	10 A	Td5	ABS ECU.
F11	10 A	300 Tdi	Not used.
F12	10 A	Td5	Engine Control Module.
F12	10 A	300 Tdi	Speed transducer.
F13	10 A	All	Brake pedal switch.
F14	10 A	All	Reverse lamp switch.
F15	5 A	All	Headlamp relay, dim dip relay, A/C compressor clutch relay, cooling fan relay, heated rear screen switch, instrument pack, ignition relay, heated front screen timer unit, blower motor relay, air conditioning unit.
F16	20 A	All	Blower motor.
F17	5 A	All	Radio/cassette player.
F18	10 A	All	RH front side lamp.
F19	10 A	130's only	LH front side lamp, LH tail lamp, instrument pack.
F19	10 A	90's and 110's only	LH front side lamp, trailer socket, instrument pack.
F20	10 A	All	RH front window switch, LH front window switch, cigar lighter, dim dip relay, headlamp levelling switch, RH headlamp levelling motor, LH headlamp levelling motor, RH heated seat switch, LH heated seat switch, rear fog lamp switch, radio/cassette player.
F21	10 A	All	Hazard warning switch.
F22	10 A	All	RH headlamp dipped beam bulb.
F23	10 A	All	LH headlamp dipped beam bulb.
F24	10 A	All	RH headlamp main beam bulb.
F25	10 A	All	LH headlamp main beam bulb.
F26	10 A	All	Rear fog lamp ECU.
F27	10 A	All	RH horn, LH horn, column switch.
F28	30 A	All	Blower relay.
F29	20 A	All	Cooling fan relay.
F30	10 A	All	Radio/cassette player, diagnostic socket.
F31	15 A	All	Hazard warning switch.
F32	20 A	All	Heated rear window relay.
F33	20 A	Td5	LH heated seat switch.
F33	20 A	300 Tdi	Not used.

FUSE DETAILS

Fuse	Rating	Vehicle	Function
F34	20 A	All	RH front window switch.
F35	20 A	All	LH front window switch.
F36	30 A	Td5	Heated front screen relay.
F36	30 A	300 Tdi	Not used.

EARTH POINTS AND HEADERS

General

The following illustration indicates the general position of each earth point and header on the vehicle. Refer to the **Connector** section for more information.

Refer to the **Circuit Diagrams** for details of electrical components and their associated earth points.

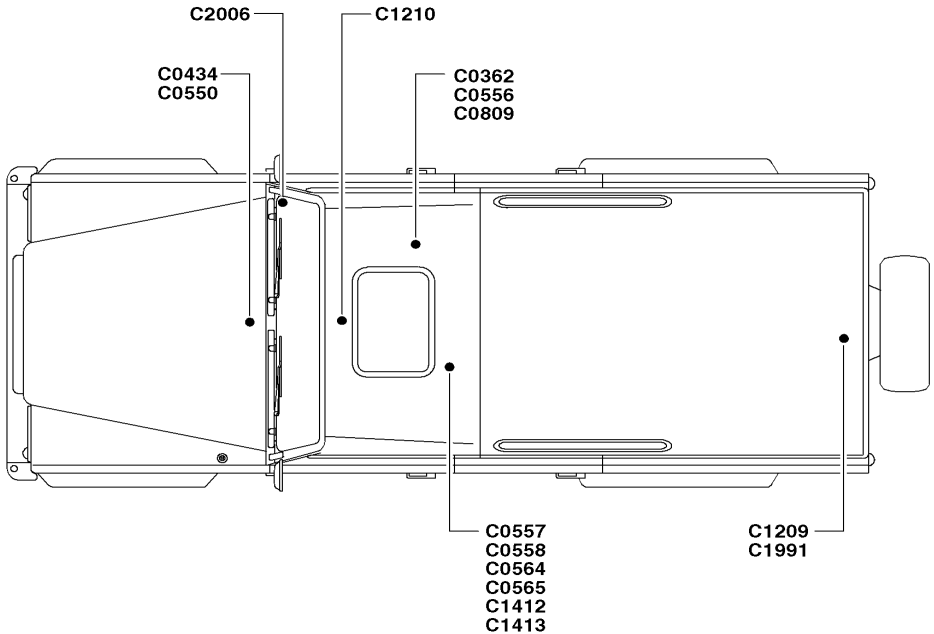

M86 5669

ANTI-THEFT ALARM AND CENTRAL DOOR LOCKING (CDL)

DESCRIPTION

General

Defender now features an enhanced 10AS anti-theft alarm system, which incorporates Central Door Locking (CDL) in addition to perimetric and volumetric protection. The perimetric alarm function monitors the hinged panels of the vehicle. If any of the doors or the bonnet are opened while the alarm is armed, the alarm will be triggered. The volumetric alarm function monitors the interior space within the passenger compartment. If any movement is sensed while the alarm is armed, the alarm will be triggered.

To arm both the perimetric and volumetric functions, the vehicle should be locked using the RF handset.

CDL is functional on all doors, and is operated by pressing the appropriate button on the RF handset.

The anti-theft alarm ECU also interacts with the Engine Control Module (ECM), causing the engine to be immobilised whenever the alarm system is armed. For more details on engine immobilisation, refer to the ***Engine Immobilisation*** section of this manual.

 **ENGINE IMMOBILISATION.**

DESCRIPTION AND OPERATION

OPERATION

Power Distribution

Feed from the positive battery terminal (C0192) is supplied to the following on an N wire:

- Fuse 6
- Fuse 7
- Fusible link 1
- Fusible link 5.

All are located in the under seat fuse box.

Fuse 6 (C0574) supplies a constant battery feed to the following:

- The anti-theft alarm ECU (C1979 on LHD vehicles, C0057 on RHD vehicles) on a PN wire
- The Battery Backed-Up Sounder (BBUS) (C0666) on a PN then B wire
- The anti-theft alarm relay (C0731) on a PN wire.

Fuse 7 (C0574) also supplies a constant battery feed to the anti-theft alarm ECU (C1980 on LHD, C0061 on RHD) on a PN wire.

Fusible link 1 is connected in series with fusible link 2, which is also located in the under seat fuse box. Fusible link 2 (C0570) supplies a constant battery feed to fuse 30 of the passenger compartment fuse box (C0595) on an NK wire. Fuse 30 (C0595) is connected to the anti-theft alarm LED (C1060) located in the instrument pack by a PN then NU wire.

Fusible link 5 (C0570) supplies a constant battery feed to the ignition switch (C1043 on LHD, C0028 on RHD) on an NW wire. When the ignition switch is turned to the 'ignition' position, current flows across the switch (C1732 on LHD, C0094 on RHD) to fuse 8 of the passenger compartment fuse box (C0580) on a W wire. Fuse 8 (C0580) supplies an ignition feed to the anti-theft alarm ECU (C1979 on LHD, C0061 on RHD) on a WG wire, and the BBUS (C0666) on a WG then B wire.

Door Switches

In order for the perimetric alarm system to operate, the anti-theft alarm ECU monitors the condition of the door switches. The door switches are open circuit when the doors are closed. When the doors are opened, the switches close and an earth path is created. The anti-theft alarm ECU (C1979 on LHD, C0061 on RHD) is connected to the door switches as follows:

- To the driver door switch (C0266 on LHD, C2007 on RHD) on an SW wire
- To the front passenger door switch (C0265 on LHD, C0106 on RHD) on a PU wire
- To the LH rear passenger door switch (5 door vehicles only) (C0104) on a PU wire
- To the RH rear passenger door switch (5 door vehicles only) (C0108) on a PU wire
- To the tail door switch (C0615 on 90 Station Wagons, C1992 on 110 Station Wagons, C1993 on 90 Hard Tops, C1994 on 110 Hard Tops) on a PU wire.

NOTE: The anti-theft alarm ECU treats the passenger doors and the tail door as a single item.

Bonnet Switch

In addition to the door switches, the anti-theft alarm ECU also monitors the condition of the bonnet switch. The bonnet switch is open circuit when the bonnet is closed. When the bonnet is opened, the switch contacts close and an earth path is created.

The anti-theft alarm ECU (C1979 on LHD, C0061 on RHD) provides a feed to the bonnet switch (C1981 on LHD, C0007 on RHD) on an OU wire. The switch is earthed on a B wire.

Volumetric Sensor

The anti-theft alarm ECU (C1979 on LHD, C0061 on RHD) provides a feed to the volumetric sensor (C0719 on Truck Cabs, C0359 on Station Wagons) on a BN wire. The volumetric sensor (C0719 on Truck Cabs, C0359 on Station Wagons) is earthed on a B wire. When the alarm is armed, the volumetric sensor (C0719 on Truck Cabs, C0359 on Station Wagons) provides a feed to the anti-theft alarm ECU (C1979 on LHD, C0061 on RHD) on a WB wire. If the sensor detects any movement within the passenger compartment, it replaces the feed with a pulsed signal. If the anti-theft alarm ECU receives a pulse of greater than 50 mS or three pulses within 1 second, it will trigger the alarm system.

DESCRIPTION AND OPERATION

Battery Backed-Up Sounder (BBUS)

Fuse 6 of the under seat fuse box (C0574) provides a constant battery feed to the BBUS (C0666) on a PN then B wire. The BBUS (C0666) is earthed on a B wire.

The anti-theft alarm ECU (C1980 on LHD, C0057 on RHD) provides a battery voltage feed to the BBUS (C0666) on an OW then B wire. If the alarm is triggered, the anti-theft alarm ECU withdraws the feed and replaces it with an earth. By pulsing the feed/earth path, the anti-theft alarm ECU can control the operation of the BBUS. The anti-theft alarm ECU will re-introduce a permanent feed to the BBUS after approximately 4.5 minutes, or if the ignition is switched on. Fuse 8 of the passenger compartment fuse box (C0580) provides an ignition feed to the BBUS (C0666) on a WG then B wire.

NOTE: The BBUS is not fitted in all markets.

Alarm Sounder

Fuse 6 of the under seat fuse box (C0574) provides a constant battery feed to the alarm relay (C0731) on a PN wire. The earth path for the relay coil is controlled by the anti-theft alarm ECU (C1980 on LHD, C0057 on RHD). The anti-theft alarm ECU (C1980 on LHD, C0057 on RHD) provides a battery voltage feed to the alarm relay coil (C0731) on an OW wire. To energise the relay, the anti-theft alarm ECU withdraws the feed and replaces it with an earth. Battery voltage from fuse 6 is now able to flow across the closed relay contacts (C0731) to the sounder (C0520) on an OB wire. The sounder (C0520) is earthed on a B wire. By pulsing the feed/earth path to the alarm relay, the anti-theft alarm ECU can control the operation of the sounder.

NOTE: The alarm sounder is not fitted in all markets.

Horns

Fuse 6 of the under seat fuse box (C0574) provides a constant battery feed to the alarm relay (C0731) on a PN wire. The earth path for the relay coil is controlled by the anti-theft alarm ECU (C1980 on LHD, C0057 on RHD). The anti-theft alarm ECU (C1980 on LHD, C0057 on RHD) provides a battery voltage feed to the alarm relay coil (C0731) on an OW wire. To energise the relay, the anti-theft alarm ECU withdraws the feed and replaces it with an earth. Battery voltage from fuse 6 is now able to flow across the closed relay contacts (C0731) to fuse 27 of the passenger compartment fuse box (C0581) on an OR wire. Fuse 27 (C0581) provides a feed to the LH horn (C0003) and the RH horn (C0004) on PB wires. By pulsing the feed/earth path to the alarm relay, the anti-theft alarm ECU can control the operation of the horns.

Anti-theft Alarm LED

The anti-theft alarm LED is located in the instrument pack, and is supplied a constant battery feed from fuse 30 of the passenger compartment fuse box (C0595) on a PN then NU wire. The earth path for the LED (C1060) is controlled by the anti-theft alarm ECU (C1980 on LHD, C0057 on RHD) on a K wire. To extinguish the LED, the ECU supplies a voltage equal to that of battery voltage along the K wire. To illuminate the LED, the ECU withdraws the feed and replaces it with an earth path. By switching from a feed to an earth path, the ECU can control the flashing sequence of the LED.

Hazard Warning Lamps

The anti-theft alarm ECU is able to control the flashing sequence of the hazard warning lamps. When the alarm is first armed, the hazard warning lamps will flash three times. When the alarm is disarmed, the hazard warning lamps will flash once. If the alarm is triggered, the hazard warning lamps will flash until the alarm system is disarmed.

To illuminate the RH hazard warning lamps, the anti-theft alarm ECU (C1980 on LHD, C0057 on RHD) provides a feed to the hazard warning switch (C0096) on a GW wire. Simultaneously, the anti-theft alarm ECU provides a feed to the hazard warning switch (C0096) on a GR wire to illuminate the LH hazard warning lamps.

NOTE: When the alarm is triggered, the anti-theft alarm ECU flashes the hazard warning lamps alternately with the BBUS/alarm sounder.

For more information on the hazard warning lamps, refer to the ***Direction Indicator/Hazard Warning Lamps*** section of this manual.



DIRECTION INDICATOR/HAZARD WARNING LAMPS.

DESCRIPTION AND OPERATION

Door Lock Motors

When the anti-theft alarm ECU (C1980 on LHD, C0057 on RHD) receives a valid lock signal from the RF handset, it provides a feed to the following on K wires:

- To the driver door lock motor (C0342)
- To the front passenger door lock motor (C0327)
- To the RH rear passenger door lock motor (C1996)
- To the LH rear passenger door lock motor (C1996)
- To the tail door lock motor (C0617).

NOTE: The RH rear and LH rear door lock motors have the same connector numbers as they utilise the same harness.

Current flows across the motors and back to the anti-theft alarm ECU (C1980 on LHD, C0057 on LHD) on O wires. When the anti-theft alarm ECU receives a valid unlock signal from the RF handset, it provides a feed to the door motors on O wires. Current flows across the motors and back to the anti-theft alarm ECU on K wires.

Interior Lamps

The anti-theft alarm ECU will illuminate the interior lamps under the following conditions:

- If the alarm system is disarmed using the remote handset
- If a door or the tail door is opened.

The anti-theft alarm ECU (C1979 on LHD, C0061 on RHD) provides a feed to the front interior lamp (C0355) and the rear interior lamp (C0356 on 90 Station Wagons, C0357 on 110 Station Wagons) on PW wires.

For more information on interior lamp operation, refer to the **Interior Lamps – Anti-theft Alarm** section of this manual.

 **INTERIOR LAMPS – ANTI-THEFT ALARM.**

Diagnostic Socket

The anti-theft alarm system can be interrogated using TestBook via the diagnostic socket. The diagnostic socket (C0040) is connected to the anti-theft alarm ECU (C1979 on LHD, C0061 on RHD) by an LG wire.

ENGINE IMMOBILISATION

DESCRIPTION

Introduction

The function of the immobilisation system is to prevent unauthorised starting of the vehicle. The system is controlled by the anti-theft alarm ECU in conjunction with the Engine Control Module (ECM) on Td5 vehicles, or the immobilisation ECU on 300 Tdi vehicles. Re-mobilisation is achieved by a transponder in the vehicle key, which is read by a transponder coil when the ignition switch is turned to the 'ignition' position.

OPERATION

Power Distribution

Feed from the positive battery terminal (C0192) is supplied to fuse 7, fusible link 1 and fusible link 5 of the under seat fuse box (C0632) on an N wire. Fuse 7 (C0574) provides a constant battery feed to the anti-theft alarm ECU (C1979 on LHD, C0061 on RHD) on a PN wire.

Fusible link 1 is connected in series with fusible link 2, which is also located in the under seat fuse box. Fusible link 2 (C0570) provides a constant battery feed to fuse 30 of the passenger compartment fuse box (C0595) on an NK wire. Fuse 30 (C0595) is connected to the engine immobilisation warning lamp (C1016) by a PN wire.

Fusible link 5 (C0570) provides a constant battery feed to the ignition switch (C1043 on LHD, C0028 on RHD) on an NW wire. When the ignition switch is turned to the 'ignition' position, current flows across the switch (C1732 on LHD, C0094 on RHD) to fuse 8 (Td5) or fuse 12 (300 Tdi) of the passenger compartment fuse box (C0580) on W wires. Fuse 8 (C0580) provides an ignition feed to the anti-theft alarm ECU (C1979 on LHD, C0061 on RHD) on a WG wire. Fuse 12 (C0580) provides an ignition feed to the immobilisation ECU (C0059) on a WG then B wire.

When the ignition switch is turned to the 'crank' position, current flows across the switch (C1732 on LHD, C0090 on RHD) to the starter relay (C0151) on a WR wire.

DESCRIPTION AND OPERATION

Transponder Coil

The transponder coil (C1318 on LHD, C0049 on RHD) is provided a battery value feed by the anti-theft alarm ECU (C1980 on LHD, C0057 on RHD) on an OP wire. The anti-theft alarm ECU (C1980 on LHD, C0057 on RHD) also provides the transponder coil (C1318 on LHD, C0049 on RHD) a pulsed feed on a OG wire. The transponder coil creates a magnetic field that excites a coil within the RF handset. This causes the RF handset to transmit a remobilisation code the anti-theft alarm ECU.

NOTE: The transponder coil is only energised when the ignition switch is turned to the 'ignition' position, and the engine is immobilised.

Anti-Theft Alarm ECU

Td5

When the anti-theft alarm ECU (C1979 on LHD, C0061 on RHD) receives an ignition feed via fuse 8 of the passenger compartment fuse box (C0508), it provides the Engine Control Module (ECM) (C0658) a coded digital signal on an LGS wire. If the coded signal matches the one expected by the ECM, the ECM will allow the engine to be started. For more information on engine starting, refer to the **Starting and Charging – Td5** section of this manual.

 **STARTING AND CHARGING – Td5.**

300 Tdi

When the anti-theft alarm ECU (C1979 on LHD, C0061 on RHD) receives an ignition feed via fuse 8 of the passenger compartment fuse box (C0508), it provides the immobilisation ECU (C0059) a coded digital signal on an LGS then B wire. If the coded signal matches the one expected by the immobilisation ECU, the immobilisation ECU will allow the engine to be started. For more information on engine starting, refer to the **Starting and Charging – 300 Tdi** section of this manual.

 **STARTING AND CHARGING – 300 Tdi.**

Immobilisation Warning Lamp

Fuse 30 of the passenger compartment fuse box (C0595) provides a constant battery feed to the immobilisation warning lamp (C1061) on a PN wire. The anti-theft alarm ECU (C1980 on LHD, C0057 on RHD) also provides a feed to the warning lamp (C0233) on an O wire. As the potential difference across the bulb is 0 V, the lamp remains extinguished. To illuminate the lamp, the anti-theft alarm ECU withdraws the feed on the O wire and provides an earth path. By switching the feed/earth on and off, the immobilisation ECU can control the flashing sequence of the warning lamp.

Starter Relay

The starter relay coil (C0151) receives an 'engine crank' feed from the ignition switch (C1731 on LHD, C0090 on RHD) on a WR wire. When the vehicle is immobilised, the anti-theft alarm ECU (C1980 on LHD, C0057 on RHD) provides a feed to the other side of the relay coil (C0151) on a BO wire. When the anti-theft alarm ECU receives a valid re-mobilisation signal, it replaces the feed to the starter relay coil on the BO wire with an earth path. The energised starter relay is now able to provide a feed to either the starter motor (C0179) on an NR wire (Td5) or the immobilisation ECU (C0059) on an NR then B wire (300 Tdi).

For more details on starting, refer to the **Starting and Charging – Td5** or **Starting and Charging – 300 Tdi** sections of this manual.



STARTING AND CHARGING – Td5.



STARTING AND CHARGING – 300 Tdi.

DESCRIPTION AND OPERATION

Immobilisation ECU – 300 Tdi Only

The immobilisation ECU (C0059) receives an ignition feed via fuse 12 of the passenger compartment fuse box (C0580) on a WG then B wire, and is earthed on a B wire.

When the ignition switch is turned to the 'ignition' position, the anti-theft alarm ECU (C1979 on LHD, C0061 on RHD) provides a coded digital signal to the immobilisation ECU (C0059) on a LGS then B wire. When the ignition switch is turned to the 'crank' position, the immobilisation ECU (C0059) receives a feed from the starter relay (C0151) on an NR then B wire. If the coded signal from the anti-theft alarm ECU has been accepted, the immobilisation ECU will provide a feed to the following on B wires:

- The fuel cut-off solenoid (C0198)
- The starter motor (C0179)
- The glow plug ECU (C0190).

Diagnostic Socket

The engine immobilisation system can be interrogated using TestBook via the diagnostic socket. The diagnostic socket (C0040) is connected to the anti-theft alarm ECU (C1979 on LHD, C0061 on RHD) by an LG wire.

WINDOWS

DESCRIPTION

Introduction

Defender is now fitted with electric front windows, which operate when the ignition switch is turned to the 'ignition' position. The window lift switches are non-latching, and are located on the fascia console.

OPERATION

Power Distribution

Feed from the positive battery terminal (C0192) is supplied to fusible link 1 and fusible link 5 of the passenger compartment fuse box (C0632) on an N wire. Fusible link 1 is connected in series with fusible link 3, which is also located in the under seat fuse box. Fusible link 3 (C0571) provides a constant battery feed to the ignition relay (C0218) on an NR wire.

Fusible link 5 (C0570) provides a constant battery feed to the ignition switch (C1043 on LHD, C0028 on RHD) on an NW wire. When the ignition switch is turned to the 'ignition' position, current flows across the switch (C1732 on LHD, C0094 on RHD) to fuse 15 of the passenger compartment fuse box (C0580) on a W wire. Fuse 15 (C0580) provides an ignition feed to the ignition relay coil (C0218) on an LGP wire. The relay coil (C0218) is earthed on a B wire.

RH Window

The energised ignition relay (C0218) provides a feed to fuse 34 of the passenger compartment fuse box (C0595) on an NS wire. Fuse 34 (C0595) is connected to the RH window switch (C0242) by an SO wire.

Up

When the window switch is moved to the 'Up' position, current flows across the switch (C0242) to the RH window lift motor (C0326) on an OR then R wire. The window lift motor (C0326) is provided an earth path via the window switch (C0242) on a U then OU then B wire. The window lift motor is now able to power the window up.

Down

When the window switch is moved to the 'Down' position, current flows across the switch (C0242) to the RH window lift motor (C0326) on an OU then U wire. The window lift motor (C0326) is provided an earth path via the window switch (C0242) on an R then OR then B wire. The window lift motor is now able to power the window down.

DESCRIPTION AND OPERATION

LH Window

The energised ignition relay (C0218) provides a feed to fuse 35 of the passenger compartment fuse box (C0595) on an NS wire. Fuse 35 (C0595) is connected to the LH window switch (C0321) by an RG wire.

Up

When the window switch is moved to the 'Up' position, current flows across the switch (C0321) to the LH window lift motor (C0326) on an R wire. The window lift motor (C0326) is provided an earth path via the window switch (C0321) on a U then B wire. The window lift motor is now able to power the window up.

Down

When the window switch is moved to the 'Down' position, current flows across the switch (C0321) to the LH window lift motor (C0326) on a U wire. The window lift motor (C0326) is provided an earth path via the window switch (C0321) on an R then B wire. The window lift motor is now able to power the window down.

NOTE: The RH and LH window lift motors have the same connector number as they are derived from the same harness drawing.

HEATED SEATS

DESCRIPTION

Introduction

Defender is now fitted with heated front seats, which operate when the ignition switch is turned to the 'ignition' position. The seat heat switches are latching switches, and are located on the fascia console. Each switch also contains a tell-tale LED.

Both seat heater elements contain a thermostatically controlled switch. When the element temperature reaches $37 \pm 3 \text{ }^\circ\text{C}$ ($98 \pm 3 \text{ }^\circ\text{F}$), the thermostat cuts the supply to the heater elements for that seat. As the temperature of the heater elements falls to $28 \pm 3 \text{ }^\circ\text{C}$ ($82 \pm 3 \text{ }^\circ\text{F}$), the thermostat closes causing the elements to heat up again.

OPERATION

Power Distribution

Feed from the positive battery terminal (C0192) is supplied to fusible link 1 and fusible link 5 of the under seat fuse box (C0632) on an N wire. Fusible link 1 is connected in series with fusible link 3, which is also located in the under seat fuse box. Fusible link 3 (C0571) provides a constant battery feed to the ignition relay (C0218) on an NR wire.

Fusible link 5 (C0570) provides a constant battery feed to the ignition switch (C1043 on LHD, C0028 on RHD) on an NW wire. When the ignition switch is turned to the 'ignition' position, current flows across the switch (C1732 on LHD, C0094 on RHD) to fuse 15 of the passenger compartment fuse box (C0580) on a W wire. Fuse 15 (C0580) provides an ignition feed to the ignition relay coil (C0218) on an LGP wire. The relay coil (C0218) is earthed on a B wire. The energised ignition relay (C0218) provides a feed to fuse 33 of the passenger compartment fuse box (C0595) on an NS wire.

RH Seat

Fuse 33 of the passenger compartment fuse box (C0595) provides a feed to the RH seat heat switch (C0249) on an LGW wire. When the seat heat switch is depressed, current flows across the switch contacts (C0249) to the seat heater element (C0237) on a UK then U wire. The heater element (C0237) is earthed on a B wire.

LH Seat

Fuse 33 of the passenger compartment fuse box (C0595) provides a feed to the LH seat heat switch (C0250) on an LGW wire. When the seat heat switch is depressed, current flows across the switch contacts (C0250) to the seat heater element (C0237) on a US then U wire. The heater element (C0237) is earthed on a B wire.

NOTE: The seat heater elements have the same connector number as they utilise the same harness.

DESCRIPTION AND OPERATION

DIAGNOSTIC SOCKET

DESCRIPTION

Introduction

The diagnostic socket is located below the centre of the fascia. It allows communication to and from off board diagnostic tools, enabling detailed fault diagnosis checks to be carried out. The socket is compliant with SAE directive J1962 standard, and allows attachment of TestBook, T4 or any other diagnostic software and tools.

OPERATION

Power Distribution

Feed from the positive battery terminal (C0192) is supplied to fusible link 1 of the under seat fuse box (C0632) on an N wire. Fusible link 1 is connected in series with fusible link 2, which is also located in the under seat fuse box. Fusible link 2 (C0570) is connected to fuse 30 of the passenger compartment fuse box (C0595) by an NK wire. Fuse 30 (C0595) provides a constant battery feed to the diagnostic socket (C0040) on a P wire. The diagnostic socket (C0040) is earthed on a pair of B wires.

Diagnostic Socket

The diagnostic socket (C0040) communicates with the following systems:

- The anti-theft alarm ECU (C1979 on LHD, C0061 on RHD) on an LG wire
- The Anti-Lock Braking System (ABS) ECU (C0504) on a K wire (Td5 vehicles only)
- The Engine Control Module (ECM) (C0658) on a K wire (Td5 vehicles only).

STARTING AND CHARGING – 300 Tdi

DESCRIPTION

Starting

The starting system on the vehicle comprises a 12 volt starter motor which drives the engine to start the combustion process. The starter converts electrical energy into mechanical power. The vehicle electrical system must be capable of supplying sufficient power to enable the engine to be cranked.

Charging

The charging system comprises a battery and an alternator. The battery must be of a sufficient capacity to operate the starter motor and operate various electrical systems in the vehicle. The alternator charges the battery when the engine is running and increases its output as demand on the battery increases.

The instrument pack incorporates a charge warning lamp which illuminates when there is no output or a low output from the alternator.

OPERATION

Power Distribution

Feed from the positive battery terminal (C0192) is supplied to fusible link 1 and fusible link 5 of the under seat fuse box (C0632) on an N wire. The battery (C0192) also provides a feed to the starter motor solenoid (C0823) on an R wire.

Fusible link 1 (C0622) provides a constant battery feed to the glow plug ECU (C0190) on an N wire. Fusible link 5 (C0570) provides a constant battery feed to the starter relay (C0151) and the ignition switch (C1043 on LHD, C0028 on RHD) on NW wires. When the ignition switch is turned to the 'ignition' position, current flows across the switch (C1732 on LHD, C0094 on RHD) to fuse 14 and fuse 15 of the passenger compartment fuse box (C0580) on a W wire. Fuse 14 (C0580) provides an ignition feed to the glow plug ECU (C0190) on an LGP then GY wire. Fuse 15 (C0580) provides an ignition feed to the ignition/no charge warning lamp located in the instrument pack (C0233) on a WG wire.

DESCRIPTION AND OPERATION

Starting

Glow Plug ECU

When the glow plug ECU (C0190) receives an ignition feed via fuse 14 of the passenger compartment fuse box (C0580), it provides a feed to the following:

- Glow plug number 4 (C1039) on a YB wire
- Glow plug number 3 (C0478) on a YB wire
- Glow plug number 2 (C0477) on a YB wire
- Glow plug number 1 (C0476) on a YB wire
- The glow plug warning lamp (C0233) on a BY wire.

The glow plugs are connected in parallel, and are all earthed via their fixings. The glow plug ECU (C0190) is earthed on a B wire.

After a pre-determined time (or if the ignition switch is turned to the crank position) the glow plug ECU withdraws the feeds to the glow plugs. For more information, refer to the **Starter Relay** description later in this section.

Glow Plug Warning Lamp

The glow plug warning lamp (C0233) is located in the instrument pack, and is provided a feed by the glow plug ECU (C0190) on a BY wire when the ignition switch is turned to the 'ignition' position. The glow plug warning lamp (C0230) is earthed on a B wire. After a pre-determined time (or if the ignition switch is turned to the crank position) the glow plug ECU withdraws the feed, extinguishing the warning lamp.

Starter Relay

When the ignition switch is turned to the 'crank' position, current flows across the switch (C1731 on LHD, C0090 on RHD) to the starter relay coil (C0151) on a WR wire. The earth path for the starter relay coil (C0151) is controlled as follows:

- On vehicles with an anti-theft alarm system, the earth path is controlled by the anti-theft alarm ECU (C1980 on LHD, C0057 on RHD) on a BO wire. For more information, refer to the **Anti-theft Alarm and Central Door Locking (CDL)** section of this manual.
 **ANTI-THEFT ALARM AND CENTRAL DOOR LOCKING (CDL).**
- On vehicles without an anti-theft alarm system fitted, the earth path is direct to earth on a B wire.

The energised starter relay (C0151) provides a feed to the immobilisation ECU (C0059) on an NR then B wire. If the vehicle has been successfully re-mobilised, the immobilisation ECU (C0059) provides a feed to the starter motor solenoid (C0179) on a B wire, and the glow plug ECU (C0190) on a B then NR wire. When the glow plug ECU receives the feed from the immobilisation ECU, it immediately cuts the feed to the glow plugs and the glow plug warning lamp.

The feed supplied by the immobilisation ECU energises the starter motor solenoid. The energised starter motor solenoid allows a battery feed to power the starter motor on an R wire.

Charging ***Alternator***

The battery (C0192) provides a permanent feed to the alternator (C0183) via the starter motor (C0178) on an R then N wire.

When the engine is started, the magnetised rotor within the stator windings generate 3 phase alternating current (ac) and voltage that rises rapidly with rotor speed. The field diodes in the rectifier pack convert the ac current into direct current (dc). Output current from the field diodes supplements the initial current flowing through the field windings. This causes an increase in the magnetic influence of the rotor, resulting in self-excitation of the alternator. The field current increases with rotor speed and thus increases the generated current and voltage until the alternator is fully excited. The alternator (C0183) charges the battery (C0192) by providing current on an N then R wire.

Ignition/No Charge Warning Lamp

Fuse 15 of the passenger compartment fuse box (C0580) provides an ignition feed to the ignition/no charge warning lamp (C0233) on a WG wire. The earth path for the warning lamp (C0233) is controlled by the alternator (C0185) on an NY wire. When the alternator outputs a voltage equal to that supplied by the battery, the warning lamp is extinguished as the potential difference across the lamp is 0 volts.

DESCRIPTION AND OPERATION

STARTING AND CHARGING – Td5

DESCRIPTION

Starting

The starting system on the vehicle comprises a 12 volt starter motor which drives the engine to start the combustion process. The starter converts electrical energy into mechanical power. The vehicle electrical system must be capable of supplying sufficient power to enable the engine to be cranked.

Charging

The charging system comprises a battery and an alternator. The battery must be of a sufficient capacity to operate the starter motor and operate various electrical systems in the vehicle. The alternator charges the battery when the engine is running and increases its output as demand on the battery increases.

The instrument pack incorporates a charge warning lamp which illuminates when there is no output or a low output from the alternator.

OPERATION

Power Distribution

Feed from the positive battery terminal (C0192) is supplied to fusible link 1 and fusible link 5 of the under bonnet fuse box (C0632) on an N wire. The battery (C0192) also provides a feed to the starter motor solenoid (C0823) on an R wire.

Fusible link 1 (C0622) provides a constant battery feed to the glow plug relay (C0215) on an N wire. Fusible link 5 (C0570) provides a constant battery feed to the starter relay (C0151) and the ignition switch (C1043 on LHD, C0028 on RHD) on NW wires. When the ignition switch is turned to the 'ignition' position, current flows across the switch (C1732 on LHD, C0094 on RHD) to fuse 12 and fuse 15 of the passenger compartment fuse box (C0580) on a W wire. Fuse 12 (C0580) provides an ignition feed to the alternator (C0226) on a WG wire. Fuse 15 (C0580) provides an ignition feed to the ignition/no charge warning lamp located in the instrument pack (C0233) on a WG wire.

Starting

Glow Plug Relay

The energised main relay (C0063) provides a feed to the glow plug relay (C0215) on an NO wire. The earth path for the glow plug relay coil (C0215) is controlled by the Engine Control Module (ECM) (C0158) on a GU wire. The ECM provides an earth path for the relay coil to control both pre and post heat. Pre-heat is determined by battery voltage and engine coolant temperature. Post heat is determined solely by engine coolant temperature.

For more information on glow plug operation, refer to the **Engine Management System – Td5** section of the Workshop manual.

The energised glow plug relay (C0215) provides a feed to the following on a YB then B wires:

- Glow plug number 1 (C0476)
- Glow plug number 2 (C0477)
- Glow plug number 3 (C0478)
- Glow plug number 4 (C0479).

NOTE: Cylinder number 5 does not have a glow plug.

Glow Plug Warning Lamp

Operation of the glow plug warning lamp is controlled by the ECM. The ECM (C0658) provides a feed to the glow plug warning lamp (C0233) on a BY wire. The lamp (C0230) is earthed on a B wire.

Starter Relay

When the ignition switch is turned to the 'crank' position, current flows across the switch (C1731 on LHD, C0090 on RHD) to the starter relay coil (C0151) on a WR wire. The earth path for the starter relay coil (C0151) is controlled by the anti-theft alarm ECU (C1980 on LHD, C0057 on RHD) on a BO wire. For more information, refer to the **Anti-theft Alarm and Central Door Locking (CDL)** section of this manual.

 **ANTI-THEFT ALARM AND CENTRAL DOOR LOCKING (CDL).**

The energised starter relay (C0151) provides a feed to the starter motor solenoid (C0179) on an NR wire. A battery feed is now able to flow across the starter motor solenoid switch contacts to power the starter motor.

DESCRIPTION AND OPERATION

Charging

Alternator

Feed from the positive battery terminal (C0192) is supplied to the alternator (C0183) via the starter motor (C0178) on an R then N wire.

When the engine is started, the magnetised rotor within the stator windings generate 3 phase alternating current (ac) and voltage that rises rapidly with rotor speed. The field diodes in the rectifier pack convert the ac current into direct current (dc). Output current from the field diodes supplements the initial current flowing through the field windings. This causes an increase in the magnetic influence of the rotor, resulting in self-excitation of the alternator. The field current increases with rotor speed and thus increases the generated current and voltage until the alternator is fully excited. The alternator (C0183) charges the battery (C0192) via the starter motor by providing current on an N then R wire.

Ignition/No Charge Warning Lamp

Fuse 13 of the passenger compartment fuse box (C0580) provides an ignition feed to the ignition/no charge warning lamp (C0233) on a WG wire. The earth path for the warning lamp (C0233) is controlled by the alternator (C0226) on an NY wire. When the alternator outputs a voltage equal to that supplied by the battery, the warning lamp is extinguished as the potential difference across the lamp is 0 volts.

ANTI-LOCK BRAKING SYSTEM (ABS)

DESCRIPTION

General

The Anti-lock Braking System (ABS) fitted to Defender operates three features:

- Anti-lock braking
- Electronic Brake force Distribution (EBD)
- Traction Control (TC).

The anti-lock braking system (ABS) is controlled by the ABS ECU, which is located beneath the RH front seat. The ABS ECU receives wheel speed information from the wheel speed sensors and monitors deceleration when the brakes are applied. If wheel deceleration is outside expected values, the ABS ECU controls the brake line pressure to each wheel via the ABS modulator. Once wheel deceleration has recovered to within allow limits, the ABS ECU allows brake pressure to be re-applied to the wheels.

When the ignition is switched on, the ABS ECU carries out a system self checking process. When this has been successfully completed, the ABS will be fully functional.

Traction Control (TC) operates in a similar manner. The ABS ECU monitors the speed of each wheel during acceleration. If any wheel is rotating faster than the others, brake pressure is applied to that wheel to slow it to the speed of the remaining three wheels.

NOTE: TC can be disabled by operating the brake pedal ten times within ten seconds, when the ignition is turned on. TC will be re-activated when the ignition is turned off then on again.

The ABS also features an Electronic Braking force Distribution (EBD) function. EBD allows the brake balance between the front and rear wheels to be maintained at an optimum level, ensuring the rear wheels don't lock before the front wheels.

DESCRIPTION AND OPERATION

OPERATION

Power Distribution

Feed from the positive battery terminal (C0192) is supplied to fusible link 1 and fusible link 5 of the under seat fuse box (C0632) on an N wire. Fusible link 1 is connected in series with fusible link 4 and fuse 1, which are also located in the under seat fuse box. Fuse 1 (C0573) provides a constant battery feed to the ABS ECU (C0504) on an NW wire. Fusible link 4 (C0571) provides a constant battery feed to the ABS modulator pump relay (C0508) on an NW wire.

Fusible link 5 (C0570) is connected to the ignition switch (C1043 on LHD, C0028 on RHD) by an NW wire. When the ignition switch is turned to the 'ignition' position, current flows across the switch (C1732 on LHD, C0094 on RHD) to fuse 11 of the passenger compartment fuse box (C0580) on a W wire. Fuse 11 (C0580) provides an ignition feed to the ABS ECU (C0504) on a GO wire.

Wheel Speed Sensors

The wheel speed sensors provide the ABS ECU with 60 pulses per wheel revolution. Each wheel speed sensor is connected to the ABS ECU via a twisted pair of wires, with both wires carrying the pulsed signal to the ABS ECU. The sensors are connected to the ABS ECU (C0505) as follows:

- The LH front wheel speed sensor (C0516) is connected to the ABS ECU via a pair of W wires.
- The RH front wheel speed sensor (C0517) is connected to the ABS ECU via a pair of G wires.
- The LH rear wheel speed sensor (C0502) is connected to the ABS ECU via a pair of W wires.
- The RH rear wheel speed sensor (C0503) is connected to the ABS ECU via a pair of G wires.

ABS Modulator Pump

The ABS modulator pump is part of the modulator assembly, and is controlled by the ABS ECU. The pump is used to increase brake line pressure. The ABS ECU (C0506) provides a feed to the modulator pump relay coil (C0508) on a WO wire. The relay coil (C0508) is earthed on a B wire. The energised modulator pump relay (C0508) allows a battery feed from fusible link 4 of the under seat fuse box (C0571) to power the modulator pump (C1587 on LHD, C0507 on RHD) on an NR wire. The pump is earthed on a B wire.

The energised modulator pump relay (C0508) also provides a feed to the ABS ECU (C0504) on an NR wire. This feed is used by the ABS ECU to monitor operation of the modulator pump.

ABS ECU and Modulator

The ABS ECU (C0506) provides outputs to the ABS modulator (C1591 on LHD, C0501 on RHD) as follows:

- The ABS modulator LH front outlet valve is driven by the ABS ECU via an SW wire.
- The ABS modulator LH front inlet valve is driven by the ABS ECU via an SR wire.
- The ABS modulator RH front outlet valve is driven by the ABS ECU via an SG wire.
- The ABS modulator RH front inlet valve is driven by the ABS ECU via an SU wire.
- The ABS modulator LH rear outlet valve is driven by the ABS ECU via an SY wire.
- The ABS modulator LH rear inlet valve is driven by the ABS ECU via an SN wire.
- The ABS modulator RH rear outlet valve is driven by the ABS ECU via an SP wire.
- The ABS modulator RH rear inlet valve is driven by the ABS ECU via an SK wire.

The ABS ECU (C0504) and the modulator (C1592 on LHD, C0500 on RHD) are both earthed on B wires.

The ABS modulator (C1591 on LHD, C0501 on RHD) provides outputs to the ABS ECU (C0506) as follows:

- An earth monitoring signal is provided to the ABS ECU on a B wire.
- A brake pedal signal is provided to the ABS ECU on an RB wire.

Engine Control Module

The Engine Control Module (ECM) provides information to the ABS ECU to enable optimum TC performance. The ECM (C0658) is connected to the ABS ECU (C0504) as follows:

- The ECM provides the ABS ECU with a Pulse Width Modulated (PWM) signal on an SP wire. This signal includes information on engine torque, engine throttle, engine type, and throttle type.
- The ECM provides the ABS ECU with pulsed voltage signal on a YK wire. This signal informs the ABS ECU of engine speed. The ECM provides the ABS ECU with two voltage pulses per engine revolution.

DESCRIPTION AND OPERATION

Instrument Pack

ABS Warning Lamp

The ABS ECU (C0504) provides a feed to the instrument pack mounted ABS warning lamp (C0230) on an RS wire. The ABS ECU illuminates the warning lamp under the following conditions:

- A bulb check when the ignition is switched on. The ABS ECU illuminates the lamp for 0.3 seconds.
- If vehicle speed remains under 7 kph (4.3 mph) after the ignition has been switched on. When vehicle speed is greater than 7 kph, the ABS ECU will extinguish the lamp.
- If a fault has been stored in the ABS ECU memory.

TC Lamp

The ABS ECU (C0504) provides a feed to the instrument pack mounted TC lamp (C0230) on a YS wire. The ABS ECU illuminates the lamp under the following conditions:

- A bulb check when the ignition is switched on. The ABS ECU illuminates the lamp for 0.3 seconds.
- For a minimum of 2 seconds if TC is active.
- If a TC fault is detected by the ABS ECU.

NOTE: The TC lamp may also illuminate if an ABS fault is detected.

Brake Warning Lamp

The ABS ECU (C0504) provides a feed to the instrument pack mounted brake warning lamp (C0230) on a BW wire. The ABS ECU illuminates the lamp under the following conditions:

- A bulb check when the ignition is switched on. The ABS ECU illuminates the lamp for 3 seconds.
- If an EBD fault is detected by the ABS ECU.

The brake warning lamp will also illuminate if the handbrake is applied, or the brake fluid level is low. The handbrake switch (C0091) is connected to the brake warning lamp (C0230) by a WY then BW wire. The brake fluid level switch (C1725 on LHD, C0026 on RHD) is connected to the brake warning lamp (C0230) by a BW wire.

Diagnostic Socket

The ABS ECU can be interrogated using TestBook via the diagnostic socket. The diagnostic socket (C0040) is located on the centre console, and is connected to the ABS ECU (C0504) by a K wire.

AIR CONDITIONING – 300 Tdi

DESCRIPTION

General

The air conditioning (A/C) system fitted to Defender operates independently of the standard heating and ventilation system. The A/C system is controlled by two rotary switches located on the driver side of the fascia; one switch controls blower speed, the other controls output temperature.

In order to gain maximum A/C system performance, the standard heater blower control should be set to '0', and both the temperature and distribution controls in the fully up position. The A/C system will then produce cooled and dehumidified air via the lower fascia vents.

NOTE: The A/C system will only operate when the engine is running.

For more information on A/C system controls and general operating procedures, refer to the **Air Conditioning** section of the Owners Handbook.

OPERATION

Power Distribution

Feed from the positive battery terminal (C0192) is supplied to fusible link 1 and fusible link 5 of the under seat fuse box (C0632) on an N wire. Fusible link 1 is connected in series with fusible link 2, which is also located in the under seat fuse box. Fusible link 2 (C0570) provides a constant battery feed to fuse 28 and fuse 29 of the passenger compartment fuse box (C0595) on an NK wire.

Fuse 28 (C0595) provides a constant battery feed to the blower motor relay (C0153) on an NP then N wire. Fuse 29 (C0595) provides a constant battery feed to the compressor clutch relay (C1268) and the cooling fan relay (C0019) on a pair of NS wires.

Fusible link 5 of the under seat fuse box (C0570) provides a constant battery feed to the ignition switch (C1043 on LHD, C0028 on RHD) on an NW wire. When the ignition switch is turned to the 'ignition' position, current flows across the switch (C1732 on LHD, C0094 on RHD) to fuse 15 (C0580) of the passenger compartment fuse box on a W wire.

DESCRIPTION AND OPERATION

Fuse 15 (C0580) provides an ignition feed to the following on WG wires:

- The blower motor relay (C0153)
- The air conditioning unit (C1273)
- The blower motor switch (C1508)
- The air conditioning temperature control switch (C0275)
- The compressor clutch relay (C1268)
- The cooling fan relay (C0019).

Blower Motor

The blower motor relay coil (C0153) receives an ignition feed from fuse 15 of the passenger compartment fuse box (C0580) on a WG wire. The relay coil (C0153) is earthed on a UB then B wire. The energised blower motor relay (C0153) provides a feed to the blower motor (C0023) on a UW wire.

Blower Speed 1

When the rotary blower switch is in position 1, current flows across the blower motor windings (C0023) to the blower motor resistor (C0425) on a U wire. The blower motor resistor (C0425) is connected to the blower motor switch (C1508) by a G wire. As current has to flow through a high resistance rating within the blower motor resistor, the blower motor operates at slow speed. The blower motor switch (C1508) is earthed on a UB then B wire.

Blower Speed 2

When the rotary blower switch is in position 2, current flows across the blower motor windings (C0023) to the blower motor resistor (C0425) on a U wire. The blower motor resistor (C0425) is connected to the blower motor switch (C1508) by an NY wire. As current has to flow through a lower resistance rating within the blower motor resistor, the blower motor operates at increased speed. The blower motor switch (C1508) is earthed on a UB then B wire.

Blower Speed 3

When the rotary blower switch is in position 3, current flows across the blower motor windings (C0023) directly to the blower motor switch (C1508) on a U wire. As the blower motor resistor is by-passed, the blower motor operates at fast speed. The blower motor switch (C1508) is earthed on a UB then B wire.

Temperature Control

The temperature control switch relays operator input to the air conditioning unit, to control A/C system temperature output. The switch (C0275) receives an ignition feed from fuse 15 of the passenger compartment fuse box (C0580) on a WG wire.

When the switch is turned to position 1, a feed is provided to the air conditioning unit (C1273) on a UY wire. When the switch is turned to position 2, a feed is provided to the air conditioning unit (C1273) on a RW wire. When the switch is turned to position 3 (maximum cooling), a feed is provided to the air conditioning unit (C1273) on a B wire.

The switch (C1273) is earthed on a UB then B wire.

Evaporator Temperature Sensor

The evaporator temperature sensor is used to ensure the evaporator doesn't freeze. The air conditioning unit (C1273) provides a feed to the temperature sensor (C0134) on a K wire, and receives a return signal on a UW wire. The air conditioning unit (C1273) is earthed on a UB then B wire.

Compressor Clutch

When A/C is requested, the compressor clutch switch contacts (C0847) close. This allows current to flow from the compressor clutch relay coil (C1268) to the pressure sensor (C0279) on a WK then BS wire.

The air conditioning unit (C1273) provides a feed to the other side of the pressure sensor (C0279) on a UG wire. If the pressure within the high pressure side of the A/C system is within operational limits, the air conditioning unit removes its feed and replaces it with a path to earth. This has the effect of energising the compressor clutch relay.

The energised compressor clutch relay (C1268) provides a feed to the compressor clutch (C0182) on a BG wire. The clutch (C0182) is earthed on a B wire.

Condenser Fan

The cooling fan relay coil (C0019) receives a feed from fuse 15 of the passenger compartment fuse box (C0580) on a WG wire. The earth path for the relay coil (C0019) is controlled by the air conditioning fan switch (C0848) on a BP wire. If condenser cooling is required, the switch contacts close, creating a path to earth on a B wire.

The energised cooling fan relay (C0019) is now able to provide a feed to the condenser fan motor (C0280) on a BN wire. The motor (C0280) is earthed on a B wire.

DESCRIPTION AND OPERATION

AIR CONDITIONING – Td5

Description

General

The air conditioning (A/C) system fitted to Defender operates independently of the standard heating and ventilation system. The A/C system is controlled by two rotary switches located on the driver side of the fascia; one switch controls blower speed, the other controls output temperature.

In order to gain maximum A/C system performance, the standard heater blower control should be set to '0', and both the temperature and distribution controls in the fully up position. The A/C system will then produce cooled and dehumidified air via the lower fascia vents.

NOTE: The A/C system will only operate when the engine is running.

For more information on A/C system controls and general operating procedures, refer to the **Air Conditioning** section of the Owners Handbook.

Operation

Power Distribution

Feed from the positive battery terminal (C0192) is supplied to fusible link 1 and fusible link 5 of the under seat fuse box (C0632) on an N wire. Fusible link 1 is connected in series with fusible link 2, which is also located in the under seat fuse box. Fusible link 2 (C0570) provides a feed to fuse 28 and fuse 29 of the passenger compartment fuse box (C0595) on an NK wire.

Fuse 28 (C0595) provides a constant battery feed to the blower motor relay (C0153) on an NP then N wire. Fuse 29 (C0595) provides a constant battery feed to the compressor clutch relay (C1268 on LHD, C0689 on RHD) and the cooling fan relay (C0019) on a pair of NS wires.

Fusible link 5 of the under seat fuse box (C0570) is connected to the ignition switch (C1043 on LHD, C0028 on RHD) by an NW wire. When the ignition switch is turned to the 'ignition' position, current flows across the switch (C1732 on LHD, C0094 on RHD) to fuse 15 and fuse 12 (C0580) of the passenger compartment fuse box on a pair of W wires.

Fuse 15 (C0580) provides an ignition feed to the following on WG wires:

- The blower motor relay (C0153)
- The air conditioning unit (C1273)
- The blower motor switch (C1508)
- The air conditioning temperature control switch (C0275).

Fuse 12 (C0580) provides an ignition feed to the Engine Control Module (ECM) (C0658) on a WG wire.

Blower Motor

The blower motor relay coil (C0153) receives an ignition feed from fuse 15 of the passenger compartment fuse box (C0580) on a WG wire. The relay coil (C0153) is earthed on a UB then B wire. The energised blower motor relay (C0153) provides a feed to the blower motor (C0023) on a UW wire.

Blower Speed 1

When the rotary blower switch is in position 1, current flows across the motor windings (C0023) to the blower motor resistor (C0425) on a U wire. The blower motor resistor (C0425) is connected to the blower motor switch (C1508) by a G wire. As current has to flow through a high resistance rating within the blower motor resistor, the blower motor operates at slow speed. The blower motor switch (C1508) is earthed on a UB then B wire.

Blower Speed 2

When the rotary blower switch is in position 2, current flows across the motor windings (C0023) to the blower motor resistor (C0425) on a U wire. The blower motor resistor (C0425) is connected to the blower motor switch (C1508) by an NY wire. As current has to flow through a lower resistance rating within the blower motor resistor, the blower motor operates at increased speed. The blower motor switch (C1508) is earthed on a UB then B wire.

Blower Speed 3

When the rotary blower switch is in position 3, current flows across the motor windings (C0023) directly to the blower motor switch (C1508) on a U wire. As the blower motor resistor is by-passed, the blower motor operates at fast speed. The blower motor switch (C1508) is earthed on a UB then B wire.

Engine Control Module

The air conditioning unit (C1273) monitors blower motor operation on a U wire. When the motor is operational, the air conditioning unit (C1273) provides a feed to the Engine Control Module (ECM) (C0658) on a WB then PB wire.

DESCRIPTION AND OPERATION

Temperature Control

The temperature control switch relays operator input to the air conditioning unit, to control A/C system temperature output. The switch (C0275) receives an ignition feed from fuse 15 of the passenger compartment fuse box (C0580) on a WG wire.

When the switch is turned to position 1, a feed is provided to the air conditioning unit (C1273) on a UY wire. When the switch is turned to position 2, a feed is provided to the air conditioning unit (C1273) on a RW wire. When the switch is turned to position 3 (maximum cooling), a feed is provided to the air conditioning unit (C1273) on a B wire.

The switch (C1273) is earthed on a UB then B wire.

Evaporator Temperature Sensor

The evaporator temperature sensor is used to ensure the evaporator doesn't freeze. The air conditioning unit (C1273) provides a feed to the temperature sensor (C0134) on a K wire, and receives a return signal on a UW wire. The air conditioning unit (C1273) is earthed on a UB then B wire.

Compressor Clutch

When A/C is requested, the air conditioning unit (C1273) provides a feed to the Engine Control Module (ECM) (C0658) via the pressure switch (C0279) on a UG then BS then YS wire. If the pressure within the high pressure side of the A/C system is within operational limits, the ECM energises the compressor clutch relay.

The compressor clutch relay coil (C0689) receives a feed from the energised main relay (C0063) on an NO wire. To energise the compressor clutch relay the ECM (C0658) provides an earth path for the relay coil (C0689) on a BS wire.

The energised compressor clutch relay (C0689) provides a feed to compressor clutch (C0182) on a BG wire. The compressor clutch (C0182) is earthed on a B wire.

Condenser Fan

The cooling fan relay coil (C0019) is provided a feed by the energised main relay (C0063) on an NO wire. To energise the cooling fan relay, the ECM (C0658) provides an earth path for the relay coil (C0019) on a BP wire. The energised cooling fan relay (C0019) is now able to provide a feed to the condenser fan motor (C0280) on a BN wire. The motor (C0280) is earthed on a B wire.

HEATER

Description

General

The heater operates when the ignition switch is turned to position I or II. The blower motor is controlled via a three position rotary switch, which is located on the driver side of the fascia. Two slider controls are also located on the fascia centre module, controlling heater temperature and direction.

Operation

Power Distribution

Feed from the positive battery terminal (C0192) is supplied to fusible link 5 of the under seat fuse box (C0632) on an N wire. Fusible link 5 (C0570) provides a constant battery feed to the ignition switch (C1043 on LHD, C0038 on RHD) on an NW wire. When the ignition switch is turned to position I, current flows across the switch (C1730 on LHD, C0099 on RHD) to fuse 16 of the passenger compartment fuse box (C0580) on a WO wire.

Blower Motor

Fuse 16 of the passenger compartment fuse box (C0580) provides a feed to the blower motor (C0023 on RHD, C0056 on RHD) on a PG wire. The earth path for the motor is controlled by the rotary heater switch.

Switch Position 0

With the rotary switch in the off position, current cannot flow across the motor windings.

Switch Position 1

With the rotary switch in position I, current flows across the motor (C0023 on LHD, C0056 on RHD) to the switch (C1508 on LHD, C0058 on RHD) on a GY wire. The switch (C1508 on LHD, C0058 on RHD) is earthed on a B wire. As current also has to flow through the in-line resistor located in the motor, the motor operates at slow speed.

Switch Position 2

With the rotary switch in position II, current flows across the motor (C0023 on LHD, C0056 on RHD) to the switch (C1508 on LHD, C0058 on RHD) on a GS wire. The switch (C1508 on LHD, C0058 on RHD) is earthed on a B wire. As current by-passes the in-line resistor located in the motor, the motor operates at high speed.

DESCRIPTION AND OPERATION

HEATED REAR WINDOW

Description

General

The Heated Rear Window (HRW) is operated via a latching switch mounted in the fascia console. When the switch is pressed, a warning lamp located in the instrument pack and a switch mounted tell-tale LED both illuminate to indicate the HRW is operating. The HRW only operates when the ignition switch is turned to the 'ignition' position.

Operation

Power Distribution

Feed from the positive battery terminal (C0192) is supplied to fusible link 1 and fusible link 5 of the under seat fuse box (C0632) on an N wire. Fusible link 1 is connected in series with fusible link 2, which is also located in the under seat fuse box. Fusible link 2 (C0570) is connected to fuse 32 of the passenger compartment fuse box (C0595) by an NK wire. Fuse 32 (C0595) provides a constant battery feed to the HRW relay (C0044) on an NO wire.

Fusible link 5 (C0570) is connected to the ignition switch (C1043 on LHD, C0028 on RHD) by an NW wire. When the ignition switch is turned to the 'ignition' position, current flows across the switch (C1732 on LHD, C0094 on RHD) to fuse 14 of the passenger compartment fuse box (C0580) on a W wire. Fuse 14 (C0580) provides an ignition feed to the HRW switch (C0072) on a WG wire.

HRW

When the HRW switch is pressed, current flows across the switch (C0072) to the HRW relay coil (C0044) on a WB wire. The relay coil (C0044) is earthed on a B wire. The energised HRW relay (C0044) provides a feed to the HRW element (C0381) on a WB wire. The element (C0381) is earthed on a B wire.

When the HRW switch is pressed, a feed is also supplied to the tell-tale LED (which is integral with the switch), and the instrument pack warning lamp (C0233) on a WB wire. For more information on the warning lamp, refer to the ***Instruments*** section of this manual.

 **INSTRUMENTS.**

HEATED FRONT SCREEN

Description

General

The Heated Front Screen (HFS) comprises two separate elements, one RH and one LH. When the switch is pressed, both elements operate simultaneously. A tell-tale LED is located in the switch to inform the driver when the HFS is operational.

Operation

Power Distribution

Feed from the positive battery terminal (C0192) is supplied to fusible link 1 and fusible link 5 of the under seat fuse box (C0632) on an N wire. Fusible link 1 (C0575) is connected to fuse 36 of the passenger compartment fuse box (C0595) by an NO wire. Fuse 36 (C0595) provides a constant battery feed to the HFS relay (C0994) on an NO wire.

Fusible link 5 is connected to the ignition switch (C1043 on LHD C0028 on RHD) by an NW wire. When the ignition switch is turned to the 'ignition' position, current flows across the switch (C1732 on LHD, C0094 on RHD) to fuse 15 of the passenger compartment fuse box (C0580) on a W wire. Fuse 15 (C0580) provides an ignition feed to the HFS timer unit (C1623) on an WG wire.

HFS Timer Unit

The HFS timer unit (C1623) monitors the condition of the HFS switch (C0131) by providing a feed on a KO wire. When the HFS switch is pressed, an earth path is created on a B wire.

In order for the HFS timer unit to operate the HFS, it must also receive an ignition feed from fuse 15 of the passenger compartment fuse box, and an engine running signal from the oil pressure switch (C0187) on a WN wire. When both of these are received, the HFS timer unit (C1623) energises the HFS relay (C0994) by providing a feed to the relay coil on a PY wire. The relay coil (C0994) is earthed on a B wire.

The energised HFS relay (C0994) provides a feed to the HFS elements (C0247) and the HFS switch tell-tale LED (C0131) on PS wires. Both are earthed on B wires.

DESCRIPTION AND OPERATION

WIPERS AND WASHERS

Description

General

The front wipers are controlled via the wash/wipe switch mounted on the steering column. The front wipers have two speed settings, a flick wipe facility, and an intermittent wipe function, which is controlled by a wiper delay ECU. The wiper delay ECU also controls the programmed wash wipe function, which is activated by pressing the end of the wash/wipe switch.

The rear screen wiper is controlled via a latching switch mounted on the fascia centre module. The rear screen wash facility is controlled via a separate non-latching switch, which is also located on the fascia centre module.

Operation

Power Distribution

Feed from the positive battery terminal (C0192) is supplied to fusible link 5 of the under seat fuse box (C0632) on an N wire. Fusible link 5 (C0570) is connected to the ignition switch (C1043 on LHD, C0028 on RHD) by an NW wire. When the ignition switch is turned to the 'ignition' position, current flows across the switch (C1732 on LHD, C0094 on RHD) to fuse 9 and fuse 10 of the passenger compartment fuse box (C0580) on a W wire.

Fuse 9 (C0580) supplies power to the front wash wipe circuit on a WG wire. Fuse 10 (C0580) supplies power to the rear wash wipe circuit on a WG wire.

Front Wipers

Fuse 9 of the passenger compartment fuse box (C0580) provides an ignition feed to the following on WG wires:

- The wash/wipe switch (C1740 on LHD, C0278 on RHD)
- The wiper delay ECU (C0303)
- The wiper motor park switch (C1593 on LHD, C0030 on RHD).

Slow Wipe

When the wash/wipe switch is moved to the slow wipe position, current flows from the switch (C1740 on LHD, C0278 on RHD) to the wiper motor (C1593 on LHD, C0030 on RHD) on a ULG wire. Current flows across the motor (C1593 on LHD, C0030 on RHD) to earth on a B wire. As current has to flow through the in-line resistor located within the wiper motor, the wiper motor operates at slow speed.

Fast Wipe

When the wash/wipe switch is moved to the fast wipe position, current flows across the switch (C1740 on LHD, C0278 on RHD) to the wiper motor (C1593 on LHD, C0030 on RHD) on a RLG wire. Current flows across the motor (C1593 on LHD, C0030 on RHD) to earth on a B wire. Current by-passes the in-line resistor located within the wiper motor, enabling the motor to operate at fast speed.

Intermittent Wipe

When the wash/wipe switch is moved to the intermittent wipe position, current flows across the switch (C1740 on LHD, C0278 on RHD) to the wiper delay ECU (C0303) on a WG wire. The wiper delay ECU (C0303) returns a pulsed voltage signal back to the wash/wipe switch (C1740 on LHD, C0278 on RHD) on a YLG wire. The pulsed voltage signal flows through the wash/wipe switch (C1740 on LHD, C0278 on RHD) to the wiper motor (C1593 on LHD, C0030 on RHD) on a ULG wire. The wiper motor operates at slow speed during the intermittent wipe function.

Flick Wipe

When the wash/wipe switch is moved upwards against (but not past) spring pressure, the wipers will operate until the switch is released. Current flows across the wash/wipe switch (C1740 on LHD, C0278 on RHD) to the wiper motor (C1593 on LHD, C0030 on RHD) on an RLG wire, powering the motor at fast speed until the wash/wipe switch is released.

Park Circuit

The park circuit allows the wipers to return to their park position when the wash/wipe switch has been moved back to the off position. The park switch is integral with the wiper motor (C1593 on LHD, C0030 on RHD), and receives an ignition feed from fuse 9 of the passenger compartment fuse box (C0580) on a WG wire.

The park switch is open circuit when the wipers are in any position other than their park position. When the wipers reach their park position, the switch contacts close, enabling the ignition feed from fuse 9 of the passenger compartment fuse box to flow to the wiper delay ECU (C0303) on an NLG wire. The wiper delay ECU (C0303) then provides a feed to the wash/wipe switch (C1740 on LHD, C0278 on RHD) on a YLG wire. The wipers continue to operate at slow speed (as described in the Slow Wipe section previously) until they reach their park position. The park switch then returns to its open position, cutting the feed to the wiper delay ECU.

DESCRIPTION AND OPERATION

Programmed Wash Wipe

Pressing the end of the wash/wipe switch initiates the programmed wash/wipe function. When the switch is pressed, current flows across the switch (C1740 on LHD, C0278 on RHD) to the windscreen washer pump (C0008) on an LGB wire. The pump (C0008) is earthed on a B wire.

When the switch is pressed, the wash/wipe switch (C1740 on LHD, C0278 on RHD) also provides a feed to the wiper delay ECU (C0303) on an LGB wire. The wiper delay ECU (C0303) will now provide a feed to the wash/wipe switch (C1740 on LHD, C0278 on RHD) on a YLG wire, which operates the wipers at slow speed (as described in the Slow Wipe section previously). When the washer switch is released, the wiper delay ECU will operate the wipers for a further three cycles.

Rear Wiper

Fuse 10 of the passenger compartment fuse box (C0580) provides a feed to the following on WG wires:

- The rear screen wiper motor park switch (C1105)
- The rear screen wiper relay (C0124)
- The rear washer switch (C0073).

The earth path for the rear screen wiper relay coil (C0124) is controlled by the rear screen wiper switch (C0079) on a BG wire. When the switch is pressed, current flows across the closed switch contacts to earth on a B wire. The energised rear screen wiper relay (C0124) provides a feed to the wiper motor (C0388) on an RLG wire. Current flows through the wiper motor (C0388) to earth on a B wire.

Park Circuit

The park circuit allows the rear screen wiper to return to its park position when the wiper switch has been switched off. The park switch is integral with the wiper motor (C1105), and receives an ignition feed from fuse 10 of the passenger compartment fuse box (C0580) on a WG wire.

The park switch is open circuit when the wiper is in any position other than its park position. When the wiper reaches its park position, the switch contacts close, enabling the ignition feed from fuse 10 of the passenger compartment fuse box to flow to the wiper relay (C0124) on an NLG wire. The de-energised relay (C0124) provides a feed to the wiper motor (C0388) on an RLG wire. The wiper continues to operate until it reaches its park position. The park switch then returns to its open position, cutting the feed to the wiper relay.

BRAKE AND REVERSE LAMPS

Description

General

The brake lamps illuminate when the ignition switch is turned to position II, and the brake pedal is pressed. The reverse lamps illuminate when the ignition switch is in position II, and the gear selector lever is in the reverse gear position.

Operation

Power Distribution

Feed from the positive battery terminal (C0192) is supplied to fusible link 5 of the under seat fuse box (C0632) on an N wire. Fusible link 5 (C0570) is connected to the ignition switch (C1043 on LHD, C0028 on RHD) by an NW wire. When the ignition switch is turned to the 'ignition' position, current flows across the switch (C1732 on LHD, C0094 on RHD) to fuse 13 and fuse 14 of the passenger compartment fuse box (C0580) on a W wire.

Brake Lamps

Fuse 13 of the passenger compartment fuse box (C0580) provides an ignition feed to the brake pedal switch (C1038 on LHD, C0075 on RHD) on a GO wire. The brake pedal switch is a normally open switch. When the brake pedal is pressed, the switch contacts close, allowing current to flow from the switch (C1727 on LHD, C0029 on RHD) to the following on GP wires:

Defender 90 and 110

- The LH brake lamp (C0121)
- The RH brake lamp (C0125)
- The Centre High Mounted Stop Lamp (CHMSL) (C0832)
- The trailer socket (C0499).

Defender 130

- The LH brake lamp (C0490)
- The RH brake lamp (C0489)
- The trailer socket (C0499).

All are earthed on B wires.

Td5 Vehicles Only

When the brake pedal is pressed, a feed is also provided to the Engine Control Module (ECM) (C0658) on a GP wire. The ECM uses this signal to help control fuelling requirements for the engine.

DESCRIPTION AND OPERATION

Reverse Lamps

Fuse 14 of the passenger compartment fuse box (C0580) provides an ignition feed to the reverse lamp switch (C0167) on an LGP then GY wire. The reverse lamp switch is a normally open switch. When reverse gear is selected, the switch contacts close, allowing current to flow from the switch (C0167) to the following:

Defender 90 and 110

- The LH reverse lamp (C0472 on LHD, C2122 on RHD) on a GN then W wire
- The trailer socket (C0942) on a GN wire.

Defender 130

- The LH reverse lamp (C2121) on a GN then W wire.
- The trailer socket (C0942) on a GN wire.

All are earthed on B wires.

HEAD, SIDE AND TAIL LAMPS

Description

General

The head, side and tail lamps are operated via the lighting switch located on the steering column. The lighting switch has two positions. Position I switches on the tail lamps, the number plate lamps, and the front side lamps. Position II additionally switches on the front headlamps. When the headlamps are on, the column switch can be used to switch between main and dipped beam. The headlamps can be flashed with the lighting switch in any position, by pulling the column switch towards the driver.

Operation

Td5

Power Distribution

Feed from the positive battery terminal (C0192) is supplied to fusible link 1, fusible link 5, and fusible link 6 of the under seat fuse box (C0632) on an R wire. Fusible link 1 is connected in series with fuse 3, which is also located in the under seat fuse box. Fuse 3 (C0572) provides a constant battery feed to the column switch (C1739 on LHD, C1042 on RHD) on an NP wire.

Fusible link 6 (C0571) provides a constant battery feed to the lighting switch (C1082 on LHD, C0041 on RHD) on an NU wire, and the dim dip resistor (C0014) on an NU then NW wire.

Fusible link 5 (C0570) is connected to the ignition switch (C1043 on LHD, C0028 on RHD) by an NW wire. When the ignition switch is turned to the 'ignition' position, current flows across the switch (C1732 on LHD, C0094 on RHD) to fuse 15 of the passenger compartment fuse box (C0580) on a W wire. Fuse 15 (C0580) provides an ignition feed to the headlamp relay (C0282) and the dim dip relay (C0048) on WG wires.

DESCRIPTION AND OPERATION

Side Lamps

When the lighting switch is moved to the side lamp position, current flows across the switch (C1082 on LHD, C0041 on RHD) to fuse 18 fuse 19 and fuse 20 of the passenger compartment fuse box (C0581) on an R wire. Fuse 18 (C0581) provides a feed to the following on RO wires:

- The RH front side lamp (C0537)
- The RH tail lamp (C0125 on 90 & 110 vehicles, C0489 on 130 vehicles)
- The trailer socket (C0499)

All are earthed on B wires.

Fuse 19 (C0581) provides a feed to the following on RB wires:

- The LH front side lamp (C0538)
- The LH tail lamp (C0121 on 90 & 110 vehicles, C0490 on 130 vehicles)
- The number plate lamp (C0138 on 90 & 110 vehicles, C0140 on 130 vehicles)
- The trailer socket (C0499)
- The side lamp warning lamp (C0233) located in the instrument pack.

All are earthed on B wires.

Fuse 20 (C0581) provides a feed to the dim dip relay (C0048) on an RO wire.

Headlamp Dim Dip

The dim dip relay (C0048) is provided an ignition feed from fuse 15 of the passenger compartment fuse box (C0580) on a WG wire. With the lighting switch in the side lamp position, the dim dip relay (C0048) is earthed on a B wire.

Fusible link 6 of the under seat fuse box (C0571) provides a constant battery feed to the dim dip resistor (C0014) on an NU then NW wire. The dim dip resistor (C0014) provides a reduced feed to the dim dip relay (C0048) on an NG wire. The energised dim dip relay (C0048) provides a feed to fuse 22 and 23 of the passenger compartment fuse box on a UR wire.

Fuse 22 (C0581) provides a reduced feed to the RH headlamp dipped beam bulb (C0011) on a UB wire. Fuse 23 (C0581) provides a reduced feed to the LH headlamp dipped beam bulb (C0009 on a UK wire. Both bulbs are earthed on B wires.

Headlamps

The headlamp relay coil (C0282) is provided an ignition feed from fuse 15 of the passenger compartment fuse box (C0580) on a WG wire. The relay coil (C0282) is earthed on a B wire. When the lighting switch is moved to the headlamp position, current flows across the switch (C1082 on LHD, C0041 on RHD) to the headlamp relay switch (C0282) on a U wire. The energised headlamp relay (C0282) provides a feed to the column switch (C1739 on LHD, C1042 on RHD) and the dim dip relay (C0048) on U wires.

NOTE: The feed on the U wire de-energises the dim dip relay.

With the column switch in the dipped beam position, current flows across the switch (C1739 on LHD, C1042 on RHD) to the dim dip relay (C0048) on a UR wire. Current flows across the dim dip relay switch contacts to fuse 22 and fuse 23 of the passenger compartment fuse box (C0581) on a UR wire.

Fuse 22 (C0581) provides a feed to the RH headlamp dipped beam bulb (C0011) on a UB wires. Fuse 23 (C0581) provides a feed to the LH headlamp dipped beam bulb (C0009) on a UK wire. Both bulbs are earthed on B wires.

With the column switch in the main beam position, current flows across the switch (C1739 on LHD, C1042 on RHD) to fuse 24 and fuse 25 of the passenger compartment fuse box (C0581) on a UW wire. Fuse 24 (C0581) provides a feed to the RH headlamp main beam bulb (C0011) on a UO wire. Fuse 25 (C0581) provides a feed to LH headlamp main beam bulb (C0009) on a US wire. Both bulbs are earthed on B wires.

When the column switch is in the main beam position, it also provides a feed to the main beam warning lamp located within the instrument pack (C0233). The warning lamp (C0230) is earthed on a B wire.

Headlamp Flash

Fuse 3 of the under seat fuse box (C0572) provides a constant battery feed to the column switch (C1739 on LHD, C1042 on RHD) on an NP wire. When the column switch is pulled forward against spring pressure, current flows across the column switch (C1739 on LHD, C1042 on RHD) to fuse 24 and fuse 25 of the passenger compartment fuse box (C0581) on a UW wire. Fuse 24 (C0581) provides a feed to the RH headlamp main beam bulb (C0011) on a UO wire. Fuse 25 (C0581) provides a feed to LH headlamp main beam bulb (C0009) on a US wire. Both bulbs are earthed on B wires.

When the column switch is pulled forward against spring pressure, it also provides a feed to the main beam warning lamp located within the instrument pack (C0233). The warning lamp (C0230) is earthed on a B wire.

DESCRIPTION AND OPERATION

300 Tdi

Power Distribution

Feed from the positive battery terminal (C0192) is supplied to fusible link 1, fusible link 5, and fusible link 6 of the under seat fuse box (C0632) on an N wire. Fusible link 1 is connected in series with fuse 3, which is also located in the under seat fuse box. Fuse 3 (C0572) provides a constant battery feed to the column switch (C1739 on LHD, C1042 on RHD) on an NP wire.

Fusible link 6 (C0571) provides a constant battery feed to the lighting switch (C1082 on LHD, C0041 on RHD) on an NU wire.

Fusible link 5 (C0570) is connected to the ignition switch (C1043 on LHD, C0094 on RHD) by an NW wire. When the ignition switch is turned to the 'ignition' position, current flows across the switch (C1732 on LHD, C0094 on RHD) to fuse 15 of the passenger compartment fuse box (C0580) on a W wire. Fuse 15 (C0580) provides an ignition feed to the headlamp relay coil (C0282) on a WG wire. The headlamp relay coil (C0282) is earthed on a B wire.

Side Lamps

When the lighting switch is moved to the side lamp position, current flows across the switch (C1082 on LHD, C0041 on RHD) to fuse 18 and fuse 19 of the passenger compartment fuse box (C0581) on an R wire. Fuse 18 (C0581) provides a feed to the following on RO wires:

- The RH front side lamp (C0537)
- The RH tail lamp (C0125 on 90 & 110, C0489 on 130 vehicles)
- The trailer socket (C0499).

All are earthed on B wires.

Fuse 19 (C0581) provides a feed to the following on RB wires:

- The LH front side lamp (C0538)
- The LH tail lamp (C0121 on 90 & 110 vehicles, C0490 on 130 vehicles)
- The number plate lamp (C0138 on 90 & 110 vehicles, C0140 on 130 vehicles)
- The trailer socket (C0499)
- The side lamp warning lamp (C0233) located in the instrument pack.

All are earthed on B wires.

Headlamps

When the lighting switch is moved to the headlamp position, current flows across the switch (C1082 on LHD, C0041 on RHD) to the energised headlamp relay (C0282) on a U wire. The headlamp relay (C0282) provides a feed to the column switch (C1739 on LHD, C1042 on RHD) on a U wire.

With the column switch in the dipped beam position, current flows across the switch (C1739 on LHD, C1042 on RHD) to fuse 22 and fuse 23 of the passenger compartment fuse box (C0581) on a UR wire.

Fuse 22 (C0581) provides a feed to the RH headlamp dipped beam bulb (C0011) on a UB wires. Fuse 23 (C0581) provides a feed to the LH headlamp dipped beam bulb (C0009) on a UK wire. Both bulbs are earthed on B wires.

With the column switch in the main beam position, current flows across the switch (C1739 on LHD, C1042 on RHD) to fuse 24 and fuse 25 of the passenger compartment fuse box (C0581) on a UW wire. Fuse 24 (C0581) provides a feed to the RH headlamp main beam bulb (C0011) on a UO wire. Fuse 25 (C0581) provides a feed to LH headlamp main beam bulb (C0009) on a US wire. Both bulbs are earthed on B wires.

When the column switch is in the main beam position, it also provides a feed to the main beam warning lamp located within the instrument pack (C0233). The warning lamp (C0230) is earthed on a B wire.

Headlamp Flash

Fuse 3 of the under seat fuse box (C0572) provides a constant battery feed to the column switch (C1739 on LHD, C1042 on RHD) on an NP wire. When the column switch is pulled forward against spring pressure, current flows across the column switch (C1739 on LHD, C1042 on RHD) to fuse 24 and fuse 25 of the passenger compartment fuse box (C0581) on a UW wire. Fuse 24 (C0581) provides a feed to the RH headlamp main beam bulb (C0011) on a UO wire. Fuse 25 (C0581) provides a feed to LH headlamp main beam bulb (C0009) on a US wire. Both bulbs are earthed on B wires.

When the column switch is pulled forward against spring pressure, it also provides a feed to the main beam warning lamp located within the instrument pack (C0233). The warning lamp (C0230) is earthed on a B wire.

DESCRIPTION AND OPERATION

HEADLAMP LEVELLING

Description

General

The headlamp levelling feature is controlled via the four position rotary switch located on the fascia centre module. Headlamp levelling should be used under the following circumstances:

- 0 – Driver, or driver and front seat passenger only (no luggage)
- 1 – Driver and three passengers (no luggage)
- 2 – Driver, three passengers and full luggage compartment
- 3 – Driver only, full luggage compartment.

Operation

Power Distribution

Feed from the positive battery terminal (C0192) is supplied to fusible link 6 of the under seat fuse box (C0632) on an N wire. Fusible link 6 (C0571) is connected to the lighting switch (C1082 on LHD, C0041 on RHD) by an NU wire.

Headlamp Levelling Switch

When the lighting switch is turned to the side or headlamp position, current flows across the switch (C1082 on LHD, C0041 on RHD) to fuse 20 of the passenger compartment fuse box (C0581) on an R wire. Fuse 20 (C0581) provides a feed to the headlamp levelling switch (C0093) on an RO wire. The switch (C0093) is earthed on a B wire.

The headlamp levelling switch has four pre-set positions. At each of the four switch positions, the contacts in the switch connect to a different resistance value to provide one of four different output voltages.

RH Headlamp Levelling Motor

Fuse 20 of the passenger compartment fuse box (C0581) provides a feed to the RH motor (C0070) on an RO wire. The headlamp levelling switch (C0093) provides a feed to the RH motor (C0070) on a UY wire. By comparing the voltage supplied by fuse 20 with the voltage supplied by the switch, the motor moves the headlamp to the required position. The motor (C0070) is earthed on a B wire.

LH Headlamp Levelling Motor

Fuse 20 of the passenger compartment fuse box (C0581) provides a feed to the LH motor (C0071) on an RO wire. The headlamp levelling switch (C0093) provides a feed to the LH motor (C0070) on a UY wire. By comparing the voltage supplied by fuse 20 with the voltage supplied by the switch, the motor moves the headlamp to the required position. The motor (C0071) is earthed on a B wire.

DESCRIPTION AND OPERATION

FOG LAMPS

Description

General

The rear fog lamps only operate when the headlamps are switched on, and the ignition switch is in position II. The non-latching fog lamp switch is mounted in the fascia console, and contains a tell-tale LED. The fog lamps are automatically switched off every time the ignition is turned off.

Operation

Power Distribution

Feed from the positive battery terminal (C0192) is supplied to fusible link 5 and fusible link 6 of the under seat fuse box (C0632) on an N wire. Fusible link 6 (C0571) provides a constant battery feed to the lighting switch (C1082 on LHD, C0041 on RHD) on an NU wire.

Fusible link 5 (C0570) is connected to the ignition switch (C1043 on RHD, C0028 on LHD) by an NW wire. When the ignition switch is turned to the 'ignition' position, current flows across the switch (C1732 on LHD, C0094 on RHD) to fuse 15 of the passenger compartment fuse box (C0580) on a W wire. Fuse 15 (C0580) provides an ignition feed to the headlamp relay coil (C0282) on a WG wire. The relay coil (C0282) is earthed on a B wire.

Fog Lamps

When the lighting switch is moved to the headlamp position, current flows across the switch (C1082 on LHD, C0041 on RHD) to the headlamp relay (C0282) on a BU wire. Current flows across the closed relay switch contacts (C0282) to fuse 26 of the passenger compartment fuse box (C0581) on a U wire. Fuse 26 (C0581) provides a feed to the fog lamp ECU (C1724 on LHD, C0543 on RHD) on a UP wire. The fog lamp ECU (C1724 on LHD, C0543 on RHD) is earthed on a B wire.

DESCRIPTION AND OPERATION

When the fog lamp ECU (C1724 on LHD, C0543 on RHD) receives a feed from fuse 26, it provides a feed to the fog lamp switch (C0064 on LHD, C1741 on RHD) on a BS wire. When the fog lamp is pressed, the switch contacts close, and a momentary earth path is created on a B wire. Sensing this earth, the fog lamp ECU (C1724 on LHD, C0543 on RHD) provides a feed to the following on RY wires:

- The tell-tale LED (C0064) located in the fog lamp switch
- The warning lamp (C0233) located in the instrument pack
- The rear fog lamp (C0512 on LHD, C2119 on RHD) – 90 and 110 vehicles only
- The rear fog lamp (C0515 on LHD, C2120 on RHD) – 130 vehicles only
- The trailer socket (C0499).

All except the trailer socket are earthed on B wires.

DESCRIPTION AND OPERATION

DIRECTION INDICATOR/HAZARD WARNING LAMPS

Description

General

The indicators are controlled via the LH steering column switch and operate when the ignition switch is in position II.

The hazard warning lamp switch is mounted on the centre fascia module. When the switch is pressed, the LH and RH indicator lamps, the switch, and the instrument pack mounted warning lamp all flash simultaneously.

Hazard warning lamp operation is not dependent on ignition switch position.

Operation

Power Distribution

Feed from the positive battery terminal (C0192) is supplied to fusible link 1 and fusible link 5 of the under seat fuse box (C0632) on an N wire. Fusible link 1 is connected in series with fusible link 2, which is also located in the under seat fuse box. Fusible link 2 (C0570) is connected to fuse 31 of the passenger compartment fuse box (C0595) by an NK wire. Fuse 31 (C0595) provides a constant battery feed to the hazard warning switch (C0096) on a PN wire.

Fusible link 5 (C0570) is connected to the ignition switch (C1043 on LHD, C0028 on RHD) by an NW wire. When the ignition switch is turned to the 'ignition' position, current flows across the switch (C1732 on LHD, C0094 on RHD) to fuse 21 of the passenger compartment fuse box (C0581) on an NW wire.

Fuse 21 (C0581) provides an ignition feed to the hazard warning switch (C0096) on a WG wire. The hazard warning switch (C0096) is now able to provide a feed to the hazard warning relay coil and switch (C0547) on a LG wire. The relay coil is earthed on a B wire. The energised hazard warning relay (C0547) provides a feed to the column switch (C1739 on LHD, C1042 on RHD) on a LGN wire.

Direction Indicator Lamps

LH Turn

When the column switch is moved to the LH position, current flows across the switch (C1739 on LHD, C1042 on RHD) to the following on GR wires:

- The LH front direction indicator lamp (C0001)
- The LH front side repeater lamp (C0013)
- The LH rear direction indicator lamp (C0928 on 90 and 100 vehicles, C1745 on 130 vehicles)
- The trailer socket (C0499)
- The LH indicator warning lamp located in the instrument pack (C0233).

All except the trailer socket are earthed on B wires. The flashing sequence of the lamps is controlled by circuitry contained within the hazard warning switch.

RH Turn

When the column switch is moved to the RH position, current flows across the switch (C1739 on LHD, C1042 on RHD) to the following on GW wires:

- The RH front direction indicator lamp (C0002)
- The RH front side repeater lamp (C0013)
- The RH rear direction indicator lamp (C0837 on 90 and 110 vehicles, C1758 on 130 vehicles)
- The trailer socket (C0499)
- The RH indicator warning lamp located in the instrument pack (C0233).

All except the trailer socket are earthed on B wires. The flashing sequence of the lamps is controlled by circuitry contained within the hazard warning switch.

Trailer Socket

When a left or right hand turn is selected, the hazard warning relay (C0547) also provides a feed to the trailer warning lamp located in the instrument pack (C0236) on an LGP wire. The trailer warning lamp will flash once, then extinguish. The lamp is earthed on a B wire.

DESCRIPTION AND OPERATION

Hazard Warning Lamps

When the hazard warning switch is pressed, current flows across the switch (C0096) to the hazard warning relay (C0547) on a LG wire. The energised hazard warning relay (C0547) provides a feed back to the hazard warning switch (C0096) on an LGN wire. The hazard warning switch (C0096) is now able to provide a feed to both the LH and RH direction indicator circuits simultaneously as follows:

- To the LH front direction indicator lamp (C0001) on a GR wire
- To the LH front side repeater lamp (C0013) on a GR wire
- To the LH rear direction indicator lamp (C0928 on 90 and 110 vehicles, C1745 on 130 vehicles) on a GR wire
- To the trailer socket (C0499) on a GR wire
- To the LH indicator warning lamp located in the instrument pack (C0233) on a GR wire
- To the RH front direction indicator lamp (C0002) on a GW wire
- To the RH front side repeater lamp (C0013) on a GW wire
- To the RH rear direction indicator lamp (C0837 on 90 and 110 vehicles, C1758 on 130 vehicles) on a GW wire
- To the trailer socket (C0499) on a GW wire
- To the RH indicator warning lamp located in the instrument pack (C0233) on a GW
- To the hazard warning lamp located in the instrument pack (C0233) on a BR wire.

All except the trailer socket are earthed on B wires. The flashing sequence of the lamps is controlled by circuitry contained within the hazard warning switch.

Anti-theft Alarm ECU

When the vehicle alarm system is armed, the anti-theft alarm ECU flashes the hazard warning lamps three times. To do this, the anti-theft alarm ECU (C1980 on LHD, C0057 on RHD) provides a pulsed feed to both the LH and RH direction indicator lamp circuits on a GR and GW wire respectively.

For more information on the anti-theft alarm system, refer to the ***Anti-theft Alarm and Central Door Locking (CDL)*** section of this manual.

 **ANTI-THEFT ALARM AND CENTRAL DOOR LOCKING (CDL).**

INTERIOR LAMPS – NON ANTI-THEFT ALARM

Description

General

Illumination of the front and rear interior lamps is controlled by the door switches. When any of the side doors are opened, both lamps will illuminate. The lamps will extinguish when all side doors are closed. The interior lamps can be switched on or off manually by moving the three position switch located on the lamp assembly to the required position.

Operation

Power Distribution

Feed from the positive battery terminal (C0192) is supplied to fusible link 1 of the under seat fuse box (C0632) on an N wire. Fusible link 1 is connected in series with fusible link 2, which is also located in the under seat fuse box. Fusible link 2 (C0570) is connected to fuse 30 of the passenger compartment fuse box (C0595) by an NK wire. Fuse 30 (C0595) provides a constant battery feed to the following on PN wires:

- The front interior lamp (C0355)
- The rear interior lamp (C0356) – 90 models only
- The rear interior lamp (C0357) – 110 models only.

Front Interior Lamp

With the lamp switch in the central position, current flows across the bulb and switch contacts (C0355) to the following:

- To the RH front door switch (C0265) on a PW wire
- To the LH front door switch (C0106) on a PW wire
- To the RH rear door switch (C0108) on a PW then PU wire
- To the LH rear door switch (C0104) on a PW then PU wire.

When any of the doors are opened, the relevant door switch contacts close creating an earth path for the lamp.

With the lamp switch in the 'On' position, current flows across the bulb and switch contacts (C1210) to earth on a B wire.

With the lamp switch in the 'Off' position, current cannot flow across the open switch contacts.

DESCRIPTION AND OPERATION

Rear Interior Lamp – 90 Models

With the lamp switch in the central position, current flows across the bulb and switch contacts (C0356) to the following:

- To the RH front door switch (C0265) on a PW wire
- To the LH front door switch (C0106) on a PW wire
- To the RH rear door switch (C0108) on a PW then PU wire
- To the LH rear door switch (C0104) on a PW then PU wire.

When any of the doors are opened, the relevant door switch contacts close creating an earth path for the lamp.

With the lamp switch in the 'On' position, current flows across the bulb and switch contacts (C1209) to earth on a B wire.

With the lamp switch in the 'Off' position, current cannot flow across the open switch contacts.

Rear Interior Lamp – 110 Models

With the lamp switch in the central position, current flows across the bulb and switch contacts (C0357) to the following:

- To the RH front door switch (C0265) on a PW wire
- To the LH front door switch (C0106) on a PW wire
- To the RH rear door switch (C0108) on a PW then PU wire
- To the LH rear door switch (C0104) on a PW then PU wire.

When any of the doors are opened, the relevant door switch contacts close creating an earth path for the lamp.

With the lamp switch in the 'On' position, current flows across the bulb and switch contacts (C1991) to earth on a B wire.

With the lamp switch in the 'Off' position, current cannot flow across the open switch contacts.

INTERIOR LAMPS – ANTI-THEFT ALARM

Description

General

On vehicles fitted with an anti-theft alarm system, illumination of the front and rear interior lamps is controlled by the anti-theft alarm ECU. The anti-theft alarm ECU monitors the condition of all the doors, illuminating the interior lamps when any door (including the tail door) is opened. The anti-theft alarm ECU also features a time-out function, which extinguishes the lamps after 8 minutes if any of the doors are left open. The anti-theft alarm ECU will also illuminate the interior lamps if the vehicle is disarmed using the remote handset.

The interior lamps can also be controlled manually, by moving the three position switch mounted in the lamp assembly to the 'On' position.

NOTE: The time-out function is by-passed if the three position switch is moved to the 'On' position.

Operation

Power Distribution

Feed from the positive battery terminal (C0192) is supplied to fusible link 1 and fuse 7 of the under seat fuse box (C0632) on an N wire. Fuse 7 (C0574) provides a constant battery feed to the anti-theft alarm ECU (C1979 on LHD, C0061 on RHD) on a PN wire.

Fusible link 1 is connected in series with fusible link 2, which is also located in the under seat fuse box. Fusible link 2 (C0570) is connected to fuse 30 of the passenger compartment fuse box (C0595) by an NK wire. Fuse 30 (C0580) provides a constant battery feed to the following on PN wires:

- The front interior lamp (C0355)
- The rear interior lamp (C0356) – 90 vehicles only
- The rear interior lamp (C0357) – 110 vehicles only.

DESCRIPTION AND OPERATION

Door Switches

The anti-theft alarm ECU (C1979 on LHD, C0061 on RHD) monitors the condition of the door switches as follows:

- The driver door switch (C0266 on LHD, C2007 on RHD) on an SW wire
- The front passenger door switch (C0265 on LHD, C0106 on RHD) on a PU wire
- The LH rear door switch (C0104) on a PU wire
- The RH rear door switch (C0108) on a PU wire
- The tail door switch (C0615) on a PU wire – 90 Station Wagons only
- The tail door switch (C1992) on a PU wire – 110 Station Wagons only
- The tail door switch (C1993) on a PU wire – 90 Hard top vehicles with Central Door Locking (CDL) only
- The tail door switch (C1994) on a PU wire – 110 Hard top vehicles with CDL only.

When any of the doors are opened, the relevant door switch contacts close creating an earth path. When the anti-theft alarm ECU registers an earth, it illuminates the interior lamps.

Front Interior Lamp

With the lamp switch in the central position, current flows across the bulb and switch contacts (C0355) to the anti-theft alarm ECU (C1979 on LHD, C0061 on RHD) on a PW wire. When the anti-theft alarm ECU registers an earth path via the door switches, it provides an earth path to illuminate the front interior lamp.

With the lamp switch in the 'On' position, current flows across the bulb and switch contacts (C1210) to earth on a B wire.

With the lamp switch in the 'Off' position, current cannot flow across the bulb and switch contacts.

Rear Interior Lamp – 90 Models

With the lamp switch in the central position, current flows across the bulb and switch contacts (C0356) to the anti-theft alarm ECU (C1979 on LHD, C0061 on RHD) on a PW wire. When the anti-theft alarm ECU registers an earth path via the door switches, it provides an earth path to illuminate the front interior lamp.

With the lamp switch in the 'On' position, current flows across the bulb and switch contacts (C1209) to earth on a B wire.

With the lamp switch in the 'Off' position, current cannot flow across the bulb and switch contacts.

Rear Interior Lamp – 110 Models

With the lamp switch in the central position, current flows across the bulb and switch contacts (C0357) to the anti-theft alarm ECU (C1979 on LHD, C0061 on RHD) on a PW wire. When the anti-theft alarm ECU registers an earth path via the door switches, it provides an earth path to illuminate the front interior lamp.

With the lamp switch in the 'On' position, current flows across the bulb and switch contacts (C1991) to earth on a B wire.

With the lamp switch in the 'Off' position, current cannot flow across the bulb and switch contacts.

DESCRIPTION AND OPERATION

INTERIOR ILLUMINATION

Description

General

With the lighting switch in either the side lamp or headlamp position, the interior controls and gauges are illuminated so they can be easily located during night driving. Interior illumination is not controlled by the ignition switch.

Operation

Power Distribution

Feed from the positive battery terminal (C0192) is supplied to fusible link 6 of the under seat fuse box (C0632) on an N wire. Fusible link 6 (C0571) is connected to the lighting switch (C1082 on LHD, C0041 on RHD) by an NU wire.

When the lighting switch is turned to the side or headlamp position, current flows across the switch (C1082 on LHD, C0041 on RHD) to fuse 18 and fuse 20 of the passenger compartment fuse box (C0581) on an R wire.

Interior Lamps

When the lighting switch is turned to the side or headlamp position, fuse 18 (C0581) provides a feed to the following on RO wires:

- The fuel gauge (C1055)
- The coolant temperature gauge (C1053)
- The speedometer (C1060)
- The clock (C0232)
- The LH heater control (C1199)
- The RH heater control (C1200)

All are earthed on B wires.

DESCRIPTION AND OPERATION

When the lighting switch is turned to the side or headlamp position, fuse 20 (C0581) provides a feed to the following on RO wires:

- The cigar lighter (C0074)
- The headlamp levelling switch (C0093)
- The heated front screen switch (C0131)
- The LH seat heat switch (C0250)
- The RH seat heat switch (C0249)
- The rear fog lamp switch (C0064 on LHD, C1741 on RHD)
- The RH front window switch (C0242)
- The LH front window switch (C0321)
- The heated rear window switch (C0072)
- The rear wiper switch (C0079)
- The radio/cassette player (C1315)
- The hazard warning switch (C0096).

All are earthed on B wires.

DESCRIPTION AND OPERATION

INSTRUMENTS

Description

General

The instrument pack relays information to the driver via the instrument pack. The instrument pack contains warning lamps and analogue gauges. The warning lamps illuminate in one of four colours, which indicate the level of the warning as follows:

- Red – Warning
- Yellow – Caution
- Green – System operative
- Blue – Headlamp main beam operative.

Operation

Power Distribution

Feed from the positive battery terminal (C0192) is supplied to fusible link 5 and fusible link 1 of the under seat fuse box (C0632) on an N wire. Fusible link 1 is connected in series with fusible link 2, which is also located in the under seat fuse box. Fusible link 2 (C0570) is connected to fuse 30 of the passenger compartment fuse box (C0595) by an NK wire. Fuse 30 (C0595) provides a constant battery feed to the engine immobilisation warning lamp (C1060) and the speedometer (C1060) on PN wires.

Fusible link 5 (C0570) is connected to the ignition switch (C1043 on LHD, C0028 on RHD) by an NW wire. When the ignition switch is turned to the 'ignition' position, current flows across the switch (C1732 on LHD, C0094 on RHD) to fuse 15 of the passenger compartment fuse box (C0580) on a W wire. Fuse 15 (C0580) provides an ignition feed to the following on WG wires:

- The fuel gauge (C1054)
- The engine coolant temperature gauge (C1052)
- The speedometer (C1060)
- The low fuel warning lamp (C0233)
- The differential lock warning lamp (C0233)
- The oil pressure warning lamp (C0233)
- The ignition/no charge warning lamp (C0236)
- The transmission oil warning lamp (C0233)
- The ABS warning lamp (C0230)
- The traction control warning lamp (C0230)
- The handbrake/low brake fluid warning lamp (C0234)
- The transmission oil warning lamp (C0234).

Fuel Gauge

Fuse 15 of the passenger compartment fuse box (C0580) provides an ignition feed to the fuel gauge (C1054) on a WG wire.

The fuel tank sender unit provides a feed to the instrument pack (C1061) on a GB then LGB wire. The voltage supplied to the instrument pack varies in relation to fuel level. The fuel gauge (C1054) is earthed on a B wire.

Engine Coolant Temperature Gauge

Fuse 15 of the passenger compartment fuse box (C0580) provides an ignition feed to the engine coolant temperature gauge (C1052) on a WG wire.

Td5

The Engine Control Module (ECM) (C0658) provides a 5 V feed to the Engine Coolant Temperature (ECT) sensor (C0169) on a KG wire. As coolant temperature increases, the resistance of the sensor decreases. By measuring the resistance of the sensor on a KB wire, the ECM can determine ECT. The ECM (C0658) then provides a Pulse Width Modulated (PWM) ECT signal to the gauge on a GU then LGU wire. The gauge (C1052) is earthed on a B wire.

300 Tdi

The Engine Coolant Temperature (ECT) sensor (C0169) provides an ECT signal to the instrument pack (C1052) on a GU then LGU wire. The gauge (C1052) is earthed on a B wire.

Speedometer

The speedometer (C1060) receives a constant battery feed from fuse 30 of the passenger compartment fuse box (C0595) on a PN wire. The speedometer (C1060) also receives an ignition feed from fuse 15 of the passenger compartment fuse box (C0580) on a WG wire. The speedometer (C1060) is earthed on a B wire.

The speed transducer (C0195) provides a square wave, pulsed speed signal to the instrument pack (C1060) on a BR wire. The instrument pack uses this signal to drive the speedometer. The speedometer also doubles the frequency of pulses (from 4100 per mile to 8200 per mile) and provides an output to the ECM (C0658 – Td5 vehicles only) and the overspeed ECU (C1311 – Gulf specification vehicles only) on YK wires.

The anti-theft alarm LED is also contained within the speedometer, and is driven by the anti-theft alarm ECU (C1980 on LHD, C0057 on RHD) on a K wire. For more information, refer to the **Anti-theft Alarm and Central Door Locking (CDL)** section of this manual.



ANTI-THEFT ALARM AND CENTRAL DOOR LOCKING (CDL).

DESCRIPTION AND OPERATION

Warning Lamps

The warning lamps operate as follows:

- Illumination of the **low fuel warning lamp** (C0233) is controlled internally within the instrument pack by the speedometer. For more information, refer to the **Fuel Gauge** section earlier.
- Illumination of the **differential lock warning lamp** (C0233) is controlled by differential lock unit (C0306) on a BU wire. When differential lock is selected, the switch contacts within the unit close creating a path to earth (C0307) on a B wire. Current from fuse 15 of the passenger compartment fuse box (C0580) is now able to flow across the bulb.
- Illumination of the **oil pressure warning lamp** (C0233) is controlled by the oil pressure switch (C0187) on a WN wire. When low oil pressure is detected by the switch, the switch contacts close creating a path to earth. Current from fuse 15 of the passenger compartment fuse box (C0580) is now able to flow across the bulb.
- Illumination of the **ignition/no charge warning lamp** (C0233) is controlled by the alternator (C0236 on Td5 vehicles, C0185 on 300 Tdi vehicles) on an NY wire. When the alternator is not producing an output voltage, current is able to flow across the bulb to earth via the alternator. When the alternator outputs a voltage equal to that supplied by fuse 15 of the passenger compartment fuse box (C0580), the lamp will extinguish as the potential difference across the lamp is 0 volts.
- Illumination of the **transmission oil warning lamp** (C0230) is controlled by the transmission oil temperature switch (C0686) on an SR wire. When transmission oil temperature exceeds the recommended limits, the switch contacts close creating a path to earth (C0687) on a B wire. Current from fuse 15 of the passenger compartment fuse box (C0580) is now able to flow across the bulb.
- Illumination of the **ABS warning lamp** is controlled by the ABS ECU. If the ABS ECU (C0504) detects a fault in the system, it provides a feed to the ABS warning lamp (C0230) on an RS wire. This triggers a series of transistors and diodes within the instrument pack to allow current from fuse 15 of the passenger compartment fuse box (C0580) to flow across the bulb. The bulb is earthed via the instrument pack on a B wire.

NOTE: If ABS isn't fitted, a shorting link is fitted to the instrument pack between C0234-6 and C0234-10. This link prevents the ABS warning lamp illuminating.

- Illumination of the **Traction Control (TC) warning lamp** (C0230) is controlled by the ABS ECU (C0504) on a YS wire. When TC is active (or if the ABS ECU detects a TC fault) the ABS ECU provides an earth path, allowing current from fuse 15 of the passenger compartment fuse box (C0580) to flow across the bulb.
- Illumination of the **handbrake/low brake fluid level warning lamp** (C0230) is controlled by the brake fluid level switch (C1725 on LHD, C0026 on RHD), and the handbrake switch (C0091).

If brake fluid level is too low, the brake fluid level switch contacts (C1726 on LHD, C0031 on RHD) will close, creating an earth path for the bulb on a B wire.

If the handbrake is applied, the switch contacts (C0091) close creating an earth path for the bulb.

NOTE: If ABS isn't fitted, a shorting link is fitted to the instrument pack between C0234-9 and C0234-13. This enables the handbrake/low brake fluid warning lamp to operate correctly in the absence of an EBD signal.

- Illumination of the **main beam warning lamp** (C0233) is controlled via the column switch (C1739 on LHD, C1042 on RHD) on a UW wire. The lamp (C0230) is earthed on a B wire. For more information, refer to the **Head, Side and Tail Lamps** section of this manual.

HEAD, SIDE AND TAIL LAMPS.

- Illumination of the **RH direction indicator warning lamp** (C0233) is controlled via the column switch (C1739 on LHD, C1040 on RHD) on a GW wire. The lamp (C0230) is earthed on a B wire. For more information, refer to the **Direction Indicator/Hazard Warning Lamps** section of this manual.

DIRECTION INDICATOR/HAZARD WARNING LAMPS.

- Illumination of the **rear fog lamp warning lamp** (C0233) is controlled by the fog lamp ECU (C1724 on LHD, C0543 on RHD) on a RY wire. The lamp (C0230) is earthed on a B wire. For more information, refer to the **Fog Lamps** section of this manual.

FOG LAMPS.

- Illumination of the **hazard warning lamp** (C0233) is controlled by the hazard warning relay (C0547) on a BR wire. The lamp (C0230) is earthed on a B wire. For more information, refer to the **Direction Indicator/Hazard Warning Lamps** section of this manual.

DIRECTION INDICATOR/HAZARD WARNING LAMPS.

DESCRIPTION AND OPERATION

- Illumination of the **engine immobilisation warning lamp** (C0233) is controlled by the anti-theft alarm ECU (C1980 on LHD, C0057 on RHD) on an O wire. For more information, refer to the **Engine Immobilisation** section of this manual.
👉 **ENGINE IMMOBILISATION.**
- Illumination of the **Heated Rear Window (HRW) warning lamp** (C0233) is controlled via the HRW relay (C0044) on a WB wire. The lamp (C0230) is earthed on a B wire. For more information, refer to the **Heated Rear Window** section of this manual.
👉 **HEATED REAR WINDOW.**
- Illumination of the **trailer warning lamp** (C0233) is controlled via the hazard warning relay (C0547) on an LGP wire. The lamp (C0230) is earthed on a B wire. For more information, refer to the **Direction Indicator/Hazard Warning Lamps** section of this manual.
👉 **DIRECTION INDICATOR/HAZARD WARNING LAMPS.**
- Illumination of the **engine management warning lamp** (C0233) is controlled by the Engine Control Module (ECM) (C0658) on an RS wire. The ECM provides an on/off signal to the warning lamp to control its flashing sequence. For more information, refer to the **Engine Management System – Td5** section of the workshop manual.
- Illumination of the **glow plug warning lamp** (C0233) is controlled by the ECM (C0658) on Td5 vehicles, or the glow plug ECU (C0190) on 300 Tdi vehicles. When the ignition switch is turned to the 'ignition' position, a feed is supplied to the warning lamp on a BY wire. The lamp (C0230) is earthed on a B wire. For more information, refer to the **Starting and Charging – 300 Tdi** or **Starting and Charging – Td5** sections of this manual.
👉 **STARTING AND CHARGING – 300 Tdi.**
👉 **STARTING AND CHARGING – Td5.**
- Illumination of the **LH direction indicator warning lamp** (C0233) is controlled via the column switch (C1739 on LHD, C1040 on RHD) on a GR wire. The lamp (C0230) is earthed on a B wire. For more information, refer to the **Direction Indicator/Hazard Warning Lamps** section of this manual.
👉 **DIRECTION INDICATOR/HAZARD WARNING LAMPS.**
- Illumination of the **side lamp warning lamp** (C0233) is controlled via the lighting switch (C1082 on LHD, C0041 on RHD) on an R then RB wire. The lamp (C0230) is earthed on a B wire. For more information, refer to the **Head, Side and Tail Lamps** section of this manual.
👉 **HEAD, SIDE AND TAIL LAMPS.**

DESCRIPTION AND OPERATION

- Illumination of the **water filter warning lamp** is controlled by the water filter sensor. When water collects in the bottom of the fuel filter, the sensor (C0735 on 90 vehicles, C1978 on 110 vehicles, C2064 on 130 vehicles) provides a feed to the warning lamp (C0230) on an OG wire. The lamp (C0234) is earthed on a B wire.
- Illumination of the **overspeed warning lamp** is controlled by the overspeed ECU (C1311) on a BK wire. For more information, refer to the **Overspeed Warning** section of this manual.

 **OVERSPEED WARNING.**

NOTE: The overspeed warning lamp is only fitted to Gulf Market Specification vehicles.

DESCRIPTION AND OPERATION

HORNS

Description

General

Defender vehicles are fitted with one or two horns (dependent on market configuration), one mounted behind each headlamp. The horn(s) are operated by pressing the end of the direction indicator switch, and are not dependent on ignition switch position.

Operation

Power Distribution

Feed from the positive battery terminal (C0192) is supplied to fusible link 1 of the under seat fuse box (C0632) on an N wire. Fusible link 1 is connected in series with fuse 3, which is also located in the under seat fuse box. Fuse 3 (C0572) provides a constant battery feed to the column switch (C1739 on LHD, C1042 on RHD) on an NP wire.

Horns

The horn switch is integral with the column switch. When the horn switch is pressed, current flows across the closed switch contacts (C1739 on LHD, C1042 on RHD) to the LH horn (C0003) and the RH horn (C0004) on PB wires. The horns are earthed on B wires.

CLOCK

Description

General

The analogue clock is located within the instrument pack. The clock is illuminated when the side or headlamps are switched on. For more information on clock illumination, refer to the *Interior Illumination* section of this manual.

 **INTERIOR ILLUMINATION.**

Operation

Power Distribution

Feed from the positive battery terminal (C0192) is supplied to fusible link 1 of the under seat fuse box (C0632) on an N wire. Fusible link 1 is connected in series with fusible link 2, which is also located in the under seat fuse box. Fusible link 2 (C0570) is connected to fuse 30 of the passenger compartment fuse box (C0595) by an NK wire.

Clock

Fuse 30 of the passenger compartment fuse box (C0595) provides a constant battery feed to the clock (C0232) on a PN wire. The clock (C0232) is earthed on a B wire.

DESCRIPTION AND OPERATION

CIGAR LIGHTER

Description

General

The cigar lighter is located in the fascia console. Pressing the centre of the cigar lighter latches the heater element into the holder. When the heating element reaches a sufficient temperature, the holder automatically releases the cigar lighter which can then be removed.

The cigar lighter holder is illuminated when the side or headlamps are switched on. For more information on cigar lighter illumination, refer to the ***Interior Illumination*** section of this manual.

 **INTERIOR ILLUMINATION.**

Operation

Power Distribution

Feed from the positive battery terminal (C0192) is supplied to fusible link 5 of the under seat fuse box (C0632) on a B wire. Fusible link 5 (C0570) is connected to the ignition switch (C1043 on LHD, C0028 on RHD) by an NW wire. When the ignition switch is turned to the 'auxiliary' position, current flows across the switch (C1730 on LHD, C0099 on RHD) to fuse 16 of the passenger compartment fuse box (C0580) on a WO wire.

Cigar Lighter

Fuse 16 of the passenger compartment fuse box (C0580) provides an auxiliary ignition feed to the cigar lighter (C0089) on a PG wire. When the cigar lighter element is pushed into the holder, an earth path is created (C0089) on a B wire. When the element reaches the correct temperature and is ejected, the circuit is broken.

ACCESSORY SOCKETS

Description

General

Two bullet style connectors are located at the rear of the vehicle and can supply battery voltage to any approved Land Rover accessory. These can be used in conjunction with the trailer socket. For more information on the trailer socket, refer to the **Trailer Socket** section of this manual.

 **TRAILER SOCKET.**

NOTE: The cigar lighter should not be used for accessory power or damage may result.

Operation

Power Distribution

Feed from the positive battery terminal (C0192) is supplied to fusible link 1 of the under seat fuse box (C0632) on an N wire. Fusible link 1 is connected in series with fuse 2, which is also located in the under seat fuse box.

Accessory Sockets

90 and 110 Vehicles

Fuse 2 of the under seat fuse box (C0573) provides a constant battery feed to the accessory socket (C1692) on a P wire. The accessory socket (C1692) is earthed on a B wire. Fuse 2 (C0573) also provides a constant battery feed to a second accessory socket (C0350) on a P wire.

A feed is also provided to the accessory socket (C0942) via the reverse lamp switch (C0167) on a GN wire

130 Vehicles

Fuse 2 of the under seat fuse box (C0573) provides a constant battery feed to the accessory socket (C0350) on a P wire. A second feed is also provided to the accessory socket (C0942) via the reverse lamp switch (C0167) on a GN wire

DESCRIPTION AND OPERATION

TRAILER SOCKET

Description

General

The 7 pin trailer socket is mounted on the rear bumper, and provides lighting and auxiliary power feeds to a trailer or caravan.

Operation

Power Distribution

Feed from the positive battery terminal (C0192) is supplied to fusible link 6 of the under seat fuse box (C0632) on an N wire. Fusible link 6 (C0571) provides a constant battery feed to the lighting switch (C1082 on LHD, C0041 on RHD) on an NU wire.

Exterior Lamps

Tail Lamps

When the lighting switch is turned to the side or headlamp position, current flows across the switch (C1082 on LHD, C0041 on RHD) to fuse 18 and fuse 19 of the passenger compartment fuse box (C0581) on an R wire. Fuse 18 (C0581) provides a feed to the trailer socket (C0499) on an RO wire. Fuse 19 (C0581) provides a feed to the trailer socket (C0499) on an RB wire.

Brake Lamps

When the brake pedal is pressed, the brake pedal switch (C1727 on LHD, C0029 on RHD) provides a feed to the trailer socket (C0499) on a GP wire.

Direction Indicator Lamps

When the column switch (C1739 on LHD, C1042 on RHD) is moved to the LH turn position, it provides a feed to the trailer socket (C0499) on a GR wire. When the column switch (C1739 on LHD, C1042 on RHD) is moved to the RH turn position, it provides a feed to the trailer socket (C0499) on a GW wire.

Hazard Warning Lamps

When the hazard warning switch (C0096) is pressed, it provides a feed to the LH and RH direction indicator circuits simultaneously, on GR and GW wires respectively.

Fog Lamps

When the rear fog lamp switch is pressed, the fog lamp ECU (C1724 on LHD, C0543 on RHD) provides a feed to the trailer socket (C0499) on an RY wire.

AUDIO SYSTEM

Description

General

The radio/cassette player is mounted in the fascia console, and will operate when the ignition switch is in the 'auxiliary' position. Two speakers are mounted in the front of the vehicle, one in each door.

NOTE: Rear speakers may also be fitted in certain markets.

Operation

Power Distribution

Feed from the positive battery terminal (C0192) is supplied to fusible link 1 and fusible link 5 of the under seat fuse box (C0632) on an N wire. Fusible link 1 is connected in series with fusible link 2, which is also located in the under seat fuse box. Fusible link 2 (C0570) is connected to fuse 30 of the passenger compartment fuse box (C0595) by an NK wire. Fuse 30 (C0595) provides a constant battery feed to the radio/cassette player (C0098 on LHD, C1315 on RHD) on a PN wire. This feed powers the radio/cassette players memory circuits.

Fusible link 5 (C0570) is connected to the ignition switch (C1043 on LHD, C0028 on RHD) by an NW wire. When the ignition switch is turned to the 'auxiliary' position, current flows across the switch (C1730 on LHD, C0099 on RHD) to fuse 17 of the passenger compartment fuse box (C0580) on a WO wire. Fuse 17 (C0580) provides an auxiliary ignition feed to the radio/cassette player (C0098 on LHD, C1315 on RHD) on a WO wire. The radio/cassette player (C0098 on LHD, C1315 on RHD) is earthed on a B wire.

DESCRIPTION AND OPERATION

Speakers

The radio/cassette player (C0092 on LHD, C1315 on RHD) is connected to the speakers as follows:

- A positive signal is provided by the radio/cassette player to the RH front speaker (C0339 on LHD, C0369 on RHD) on a BK wire. The RH front speaker (C1493 on LHD, C1577 on LHD) is provided a negative signal by the radio/cassette player (C0092 on LHD, C1315 on RHD) on a BR wire.
- A positive signal is provided by the radio/cassette player to the LH front speaker (C0340) on a BW wire. The LH front speaker (C1492) is provided a negative signal by the radio/cassette player (C0092 on LHD, C1315 on RHD) on a BN wire.
- A positive signal is provided by the radio/cassette player to the RH rear speaker (C0311) on a BY wire. The RH rear speaker (C0310) is provided a negative signal by the radio/cassette player (C0092 on LHD, C1315 on RHD) on a BO wire.
- A positive signal is provided by the radio/cassette player to the LH rear speaker (C0309) on a BG wire. The LH rear speaker (C0308) is provided a negative signal by the radio/cassette player (C0092 on LHD, C1315 on RHD) on a BU wire.

NOTE: It is essential that the speakers are connected correctly. If the speakers are connected incorrectly they will be out of phase, causing a deterioration of sound quality.

FUEL PUMP

Description

General

The fuel pump is located above the fuel tank, and is controlled by the Engine Control Module (ECM) via the fuel pump relay. For more information on the Td5 fuel system, refer to the ***Fuel System Td5*** section of the workshop manual.

Operation

Power Distribution

Feed from the positive battery terminal (C0192) is supplied to the following on an N wire.

- Fusible link 5
- Fuse 4
- Fuse 5.

All are located in the under seat fuse box (C0632).

Fuse 4 (C0573) provides a constant battery feed to the fuel pump relay (C0730) on a PW wire. Fuse 5 (C0574) provides a feed to the main relay (C0063) and the inertia switch (C0123) on NLG wires. Fusible link 5 (C0570) provides a feed to the ignition switch (C1043 on LHD, C0028 on RHD) on an NW wire.

When the ignition switch is turned to the 'ignition' position, current flows across the switch (C1732 on LHD, C0094 on RHD) to fuse 11 of the passenger compartment fuse box (C0580) on a W wire. Fuse 11 (C0580) provides an ignition feed to the ECM (C0658) on a WG wire.

Main Relay

The main relay coil (C0063) is provided a constant battery feed via the inertia switch (C0123) on an N wire. When the ECM (C0658) receives an ignition switch feed from fuse 11 of the passenger compartment fuse box (C0580), it provides an earth path for the main relay coil (C0063) on a UR wire. The energised main relay (C0063) is now able to provide a feed to the fuel pump relay (C0730) and back to the ECM (C0658) on a series of NO wires.

DESCRIPTION AND OPERATION

Fuel Pump Relay

The fuel pump relay coil (C0730) receives a feed from the energised main relay (C0063) on an NO wire. If the ECM (C0658) has received the correct re-mobilisation signal from the anti-theft alarm ECU, it provides an earth path for the fuel pump relay coil (C0730) on a UP wire.

The energised fuel pump relay (C0730) is now able to provide a feed to the fuel pump (C0114 on 90 models, C0115 on 110 vehicles, C2063 on 130 vehicles) on a WP wire. The fuel pump (C0114 on 90 models, C0115 on 110 vehicles, C2063 on 130 vehicles) is earthed on a B wire.

Fuel Tank Sender Unit

The fuel tank sender unit (C0114 on 90 models, C0115 on 110 vehicles, C2063 on 130 vehicles) is provided a feed by the energised fuel pump relay (C0730) on a WP wire. The output voltage supplied by the sender to the instrument pack (C1061) on a GB wire varies in relation to fuel level. The sender unit (C0114 on 90 models, C0115 on 110 vehicles, C2063 on 130 vehicles) is earthed on an SB then B wire.

For more information on fuel gauge operation, refer to the ***Instruments*** section of this manual.

 **INSTRUMENTS.**

OVERSPEED WARNING

Description

General

Overspeed Warning informs the driver if the vehicle is travelling at speeds in excess of 120 kph (75 mph) by illuminating a warning lamp located in the instrument pack. The system is controlled by the overspeed ECU, which is located adjacent the passenger compartment fuse box.

NOTE: Overspeed warning is only fitted to Gulf Market Specification vehicles.

Operation

Power Distribution

Feed from the positive battery terminal (C0192) is supplied to fusible link 5 of the under seat fuse box (C0632) on an N wire. Fusible link 5 (C0570) is connected to the ignition switch (C1043) by an NW wire. When the ignition switch is turned to the 'ignition' position, current flows across the switch (C1732) to fuse 15 of the passenger compartment fuse box (C0580) on a W wire. Fuse 15 (C0580) provides an ignition feed to the overspeed ECU (C1311) on a WG wire. The ECU (C1311) is earthed on a B wire.

Road Speed

The speed transducer (C0195) provides a pulsed road speed signal to the instrument pack (C1060) on a BR wire. The transducer is located within the transfer box, and provides 4100 voltage pulses per mile. The instrument pack (C1060) doubles the frequency of the pulses and provides this signal to the overspeed ECU (C1311) on a YK wire.

Warning Lamp

If road speed reaches 123.5 kph (77 mph), the overspeed ECU (C1311) illuminates the warning lamp located in the instrument pack (C0236) by providing a feed on a BK wire. The bulb will remain illuminated until road speed drops to 117.5 kph (73 mph).

DESCRIPTION AND OPERATION

CONNECTOR REFERENCE NUMBERS

CONNECTOR APPLICABILITY

General

The following table lists the circuit reference numbers against a description of the model or feature to which they apply. This information should be used in conjunction with the connector pin-out tables on the following pages to determine the wire configuration of the vehicle being worked on.

Cct	Model or Feature
1	All
2	LHD
3	RHD
4	Td5 (All)
5	Td5 (LHD Only)
6	Td5 (RHD Only)
7	300 Tdi (All)
8	300 Tdi (LHD Only)
9	300 Tdi (RHD Only)
10	90 (All except Pick-Up)
11	90 (Td5 Only)
12	90 (300 Tdi Only)
13	110 (All except Pick-Up)
14	110 (Td5 Only)
15	110 (300 Tdi Only)
16	130 (All)
17	130 (Td5 Only)
18	130 (300 Tdi Only)
19	Anti-theft Alarm & Central Door Locking
20	Anti-theft Alarm & Central Door Locking (LHD Only)
21	Anti-theft Alarm & Central Door Locking (RHD Only)
22	Dim Dip
23	Non Dim Dip
24	Central Door Locking (90's Only)
25	Air Conditioning
26	Cold Climate Pack
27	Electric Front Windows (All)
28	Electric Front Windows (LHD Only)
29	Electric Front Windows (RHD Only)

CONNECTOR

Cct	Model or Feature
30	Manual Locking (All)
31	Manual Locking (LHD Only)
32	Manual Locking (RHD Only)
33	Anti-theft Alarm (Pick-Up Only)
34	Anti-theft Alarm (Station Wagons Only)
35	90 (Pick-Up Only)
36	Low Line Audio System
37	High Line Audio System
38	CDL – Driver Door
39	CDL – Passenger Door
40	Headlamp Levelling
41	South African Vehicles Only
42	Military Vehicles Only
43	Italian Police Vehicles Only
44	Central Door Locking (110's Only)
45	Pre 02MY Vehicles Only
46	Exhaust Gas Recirculation
47	110 (Pick-Up Only)

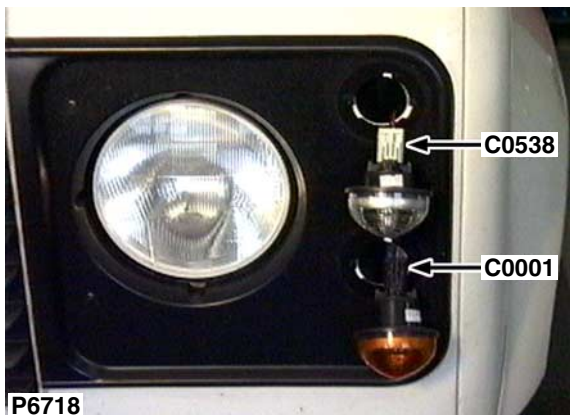

Cav	Col	Cct
1	B	ALL
2	GR	ALL

Description: *Lamp - Direction indicator / hazard warning - Front - LH*
 Location: *Behind LH front indicator lamp*

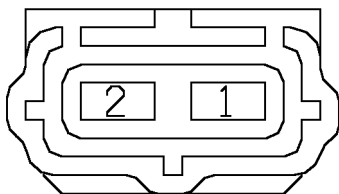

YPC10070

Colour: *BLACK*
 Gender: *Female*

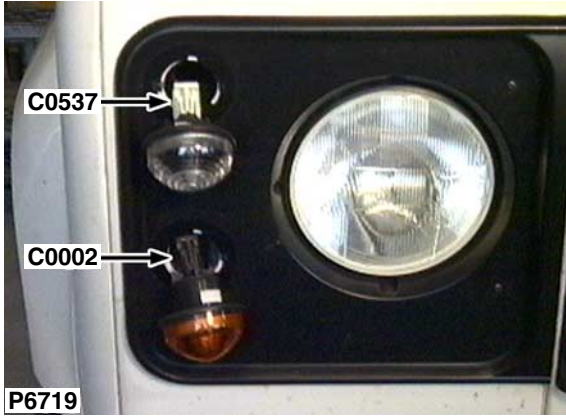

Cav	Col	Cct
1	B	ALL
2	GW	ALL

Description: *Lamp - Direction indicator / hazard warning - Front - RH*
Location: *Behind RH front indicator lamp*

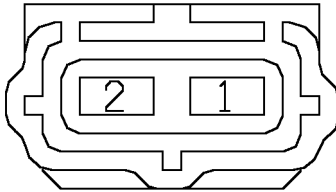

YPC10070

Colour: *BLACK*
Gender: *Female*

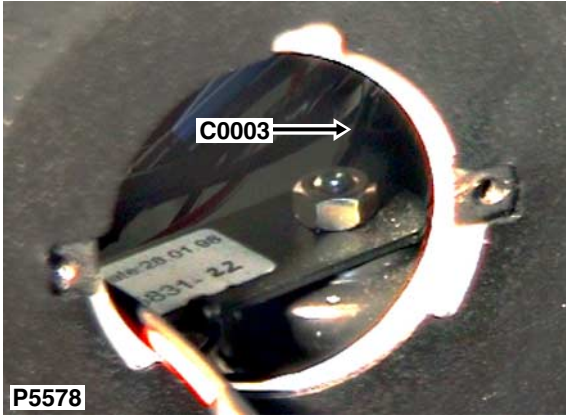

P5578

Description: *Horn - LH*

Location: *Behind LH headlamp*

Cav	Col	Cct
1	B	ALL
2	PB	1

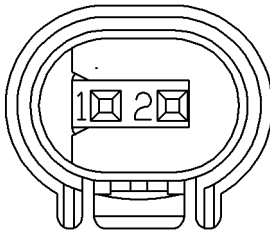

YPC110600

Colour: *LIGHT BLUE*

Gender: *Female*

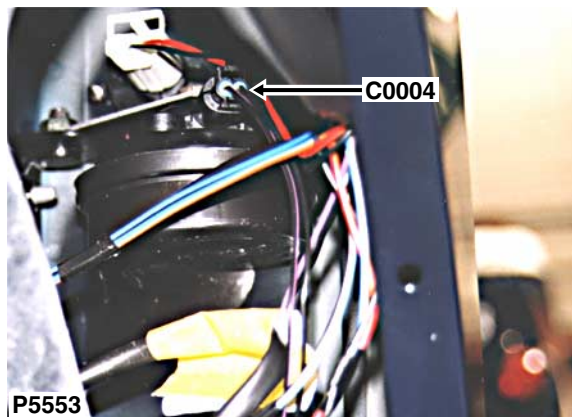

Cav	Col	Cct
1	B	ALL
2	PB	1

Description: *Horn - RH*

Location: *Behind RH headlamp*

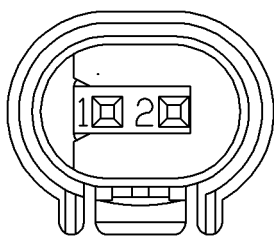

YPC110600

Colour: *LIGHT BLUE*

Gender: *Female*

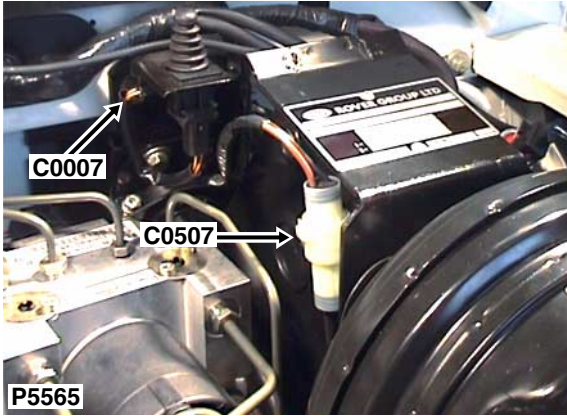

Cav	Col	Cct
1	B	21
2	OU	21

Description: *Switch - Bonnet*
Location: *Adjacent pedal box*

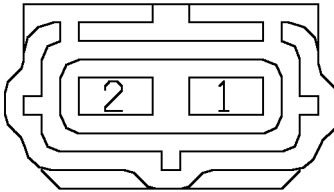

YPC10070

Colour: *BLACK*
Gender: *Female*

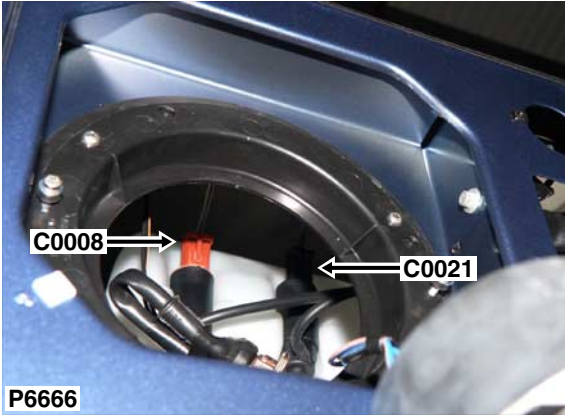

Cav	Col	Cct
1	B	ALL
2	LGB	ALL

Description: *Pump - Washer - Windscreen*
Location: *Behind LH headlamp*

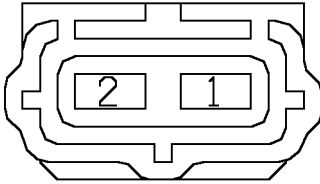

YPC10131

Colour: *RED*
Gender: *Female*

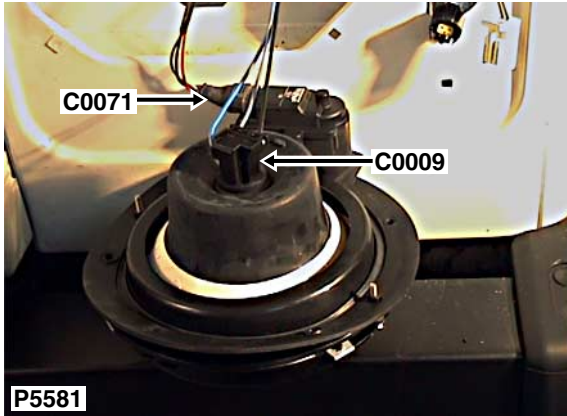

Cav	Col	Cct
1	US	ALL
2	UK	ALL
3	B	ALL

Description: *Headlamp - LH*
 Location: *Behind LH headlamp*

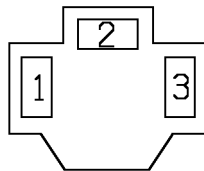

AFU3113

Colour: *BLACK*
 Gender: *Female*

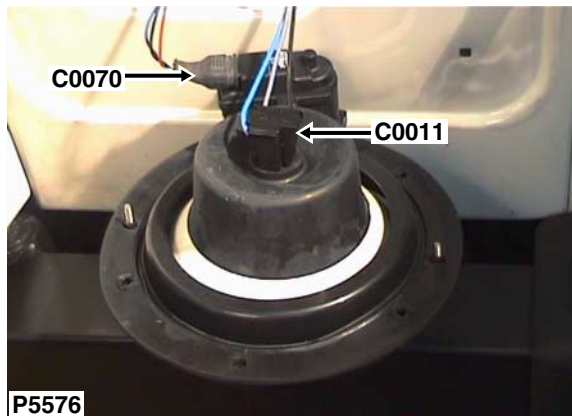

Cav	Col	Cct
1	UO	ALL
2	UB	ALL
3	B	ALL

Description: *Headlamp - RH*

Location: *Behind RH headlamp*

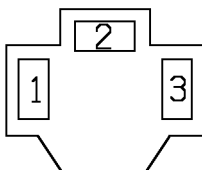

AFU3113

Colour: *BLACK*

Gender: *Female*



Cav	Col	Cct
1	GW	ALL
2	B	ALL

P5580

Description: *Lamp - Side repeater - Front - RH*

Location: *Behind RH side repeater lamp*

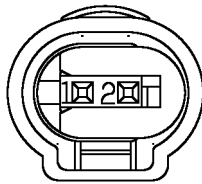

YPC116820

Colour: *BLACK*

Gender: *Female*

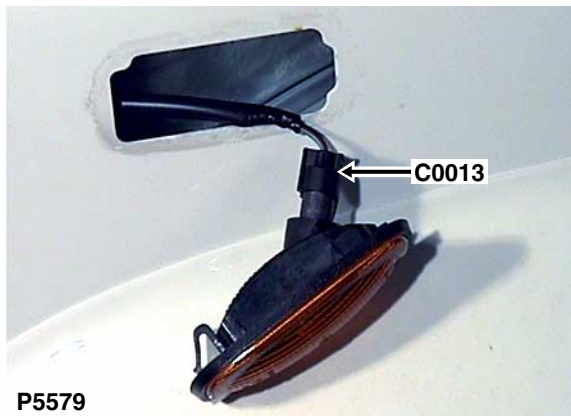

P5579

Description: *Lamp - Side repeater - Front - LH*

Location: *Behind LH side repeater lamp*

Cav	Col	Cct
1	GR	ALL
2	B	ALL

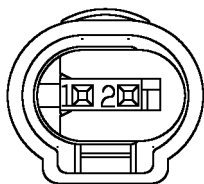

YPC116820

Colour: *BLACK*

Gender: *Female*

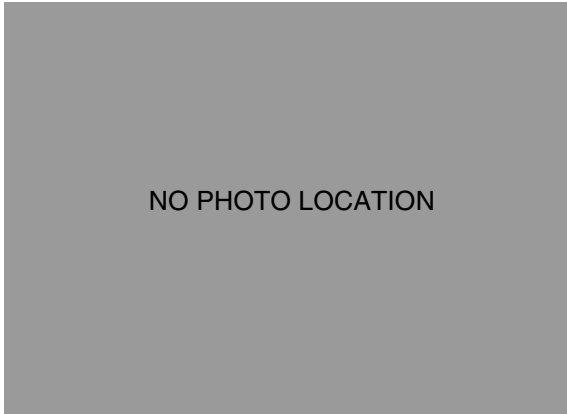

Cav	Col	Cct
1	NW	37
2	NG	37

Description: *Resistor - Dim dip*

Location: *Behind RH side repeater lamp*

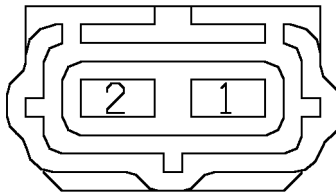

YPC10070

Colour: *BLACK*

Gender: *Female*

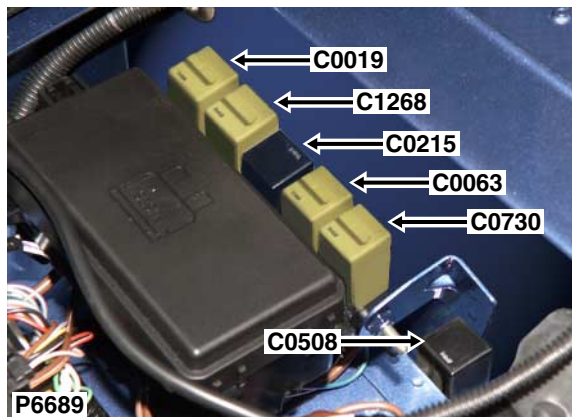

Cav	Col	Cct
30	NS	25
85	NO	25
85	WG	25
86	BP	25
87	BN	25

Description: *Relay - Air conditioning (A/C) - Td5*

Location: *Beneath RH seat*

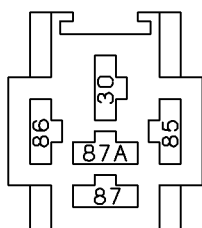

AFU3271

Colour: *YELLOW*

Gender: *Female*

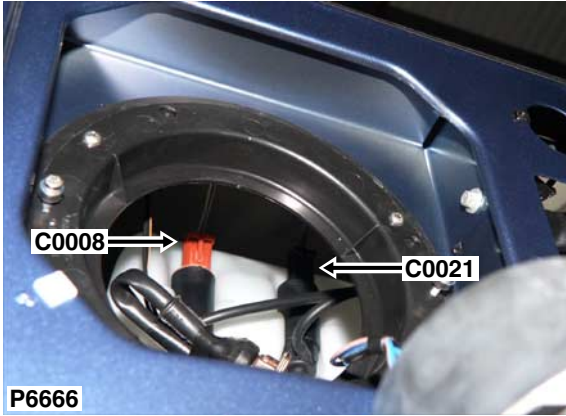

Cav	Col	Cct
1	B	ALL
2	BLG	ALL

Description: *Pump - Washer - Rear screen*
 Location: *Behind LH headlamp*

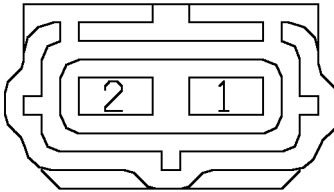

YPC10070

Colour: *BLACK*
 Gender: *Female*

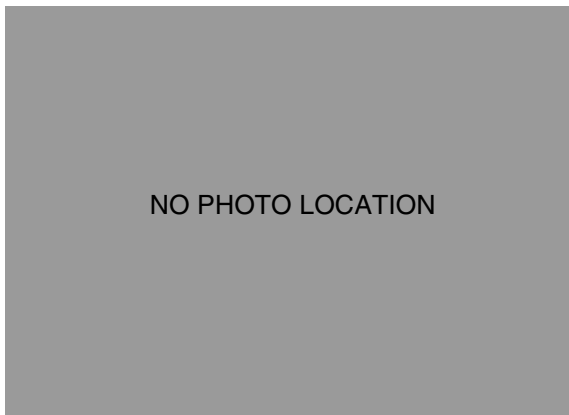

Cav	Col	Cct
1	GS	2
2	GY	2
3	PG	2

Description: *Motor - Blower*

Location: *Behind RH side of fascia*

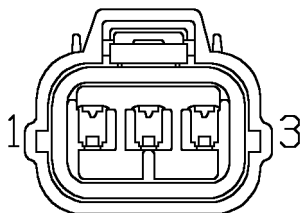

YPC10181

Colour: *LIGHT GREY*

Gender: *Female*

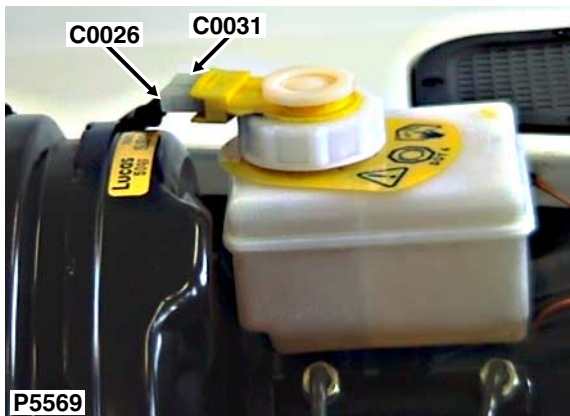

Cav	Col	Cct
1	BW	3

Description: *Switch - Brake fluid level*

Location: *Adjacent pedal box*

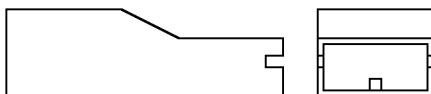

ADU8339

Colour: *NATURAL*

Gender: *Female*

C0027

CONNECTOR DETAILS

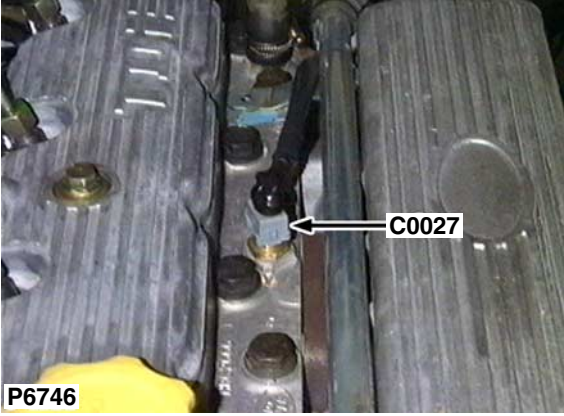

Cav	Col	Cct
1	GU	46
2	KB	46

Description: *Sensor - Temperature - EGR*

Location: *Top of engine*

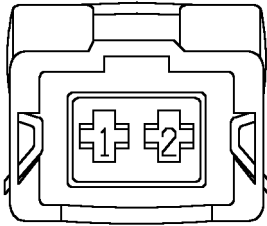

YPC107820

Colour: *GREY*

Gender: *Female*

Cav	Col	Cct
1	NW	3

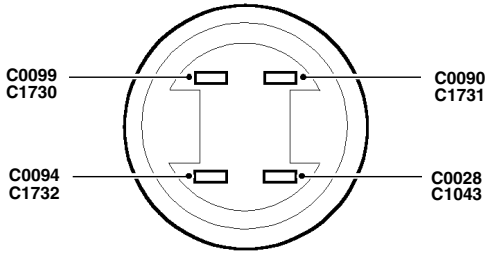

Description: *Switch - Ignition*
 Location: *Behind instrument pack*

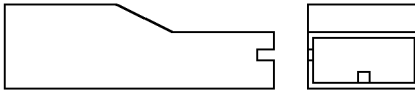

AAU1010

Colour: *BLACK*
 Gender: *Female*

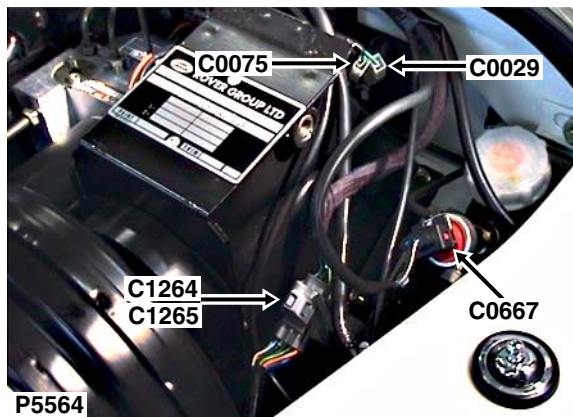

Cav	Col	Cct
1	GP	3

Description: *Switch - Brake pedal*

Location: *Adjacent pedal box*

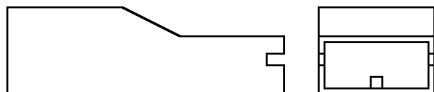

ADU8339

Colour: *NATURAL*

Gender: *Female*

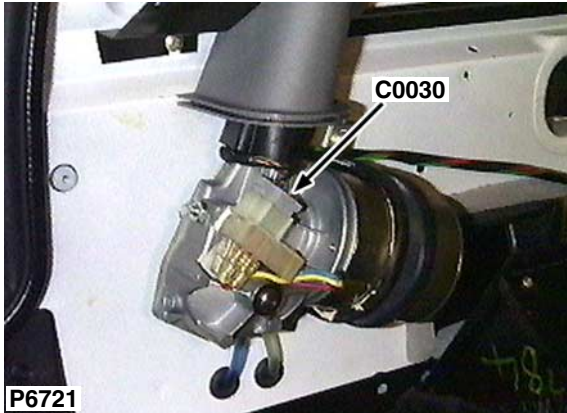

Cav	Col	Cct
1	B	ALL
2	NLG	ALL
3	ULG	ALL
4	WG	ALL
5	RLG	ALL

Description: *Motor - Wiper - Windscreen*

Location: *Behind LH side of fascia*

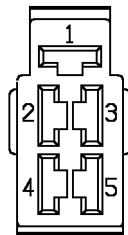

13H4576

Colour: *LIGHT GREY*

Gender: *Female*

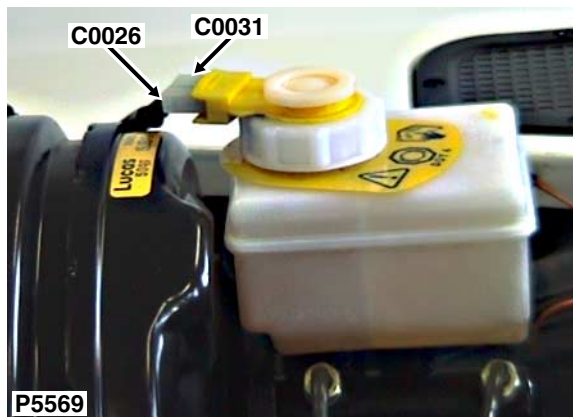

Cav	Col	Cct
1	B	3

Description: *Switch - Brake fluid level*

Location: *Adjacent pedal box*

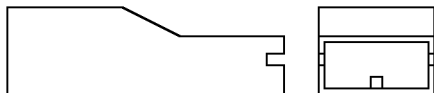

ADU8339

Colour: *NATURAL*

Gender: *Female*

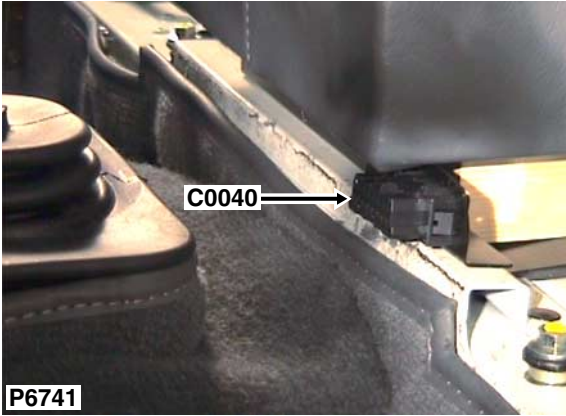

Cav	Col	Cct
4	B	ALL
5	B	ALL
7	K	4
8	OLG	ALL
16	PN	ALL

Description: *Diagnostic socket*
 Location: *Behind front of centre console*

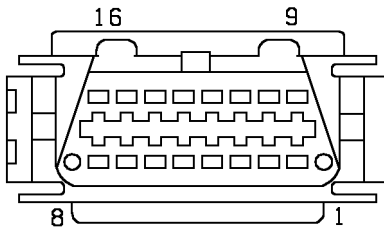

YPC107920

Colour: *BLACK*
 Gender: *Female*

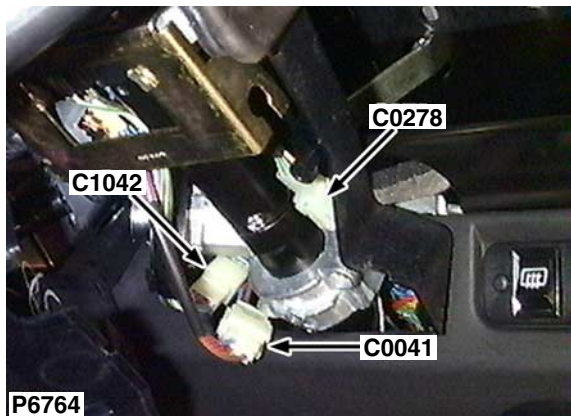

Cav	Col	Cct
1	NU	ALL
2	R	3
4	U	3

Description: *Switch - Lighting*

Location: *Behind steering column cowl LH side*

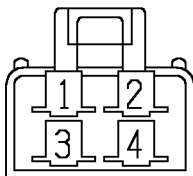

AFU3855

Colour: *NATURAL*

Gender: *Female*

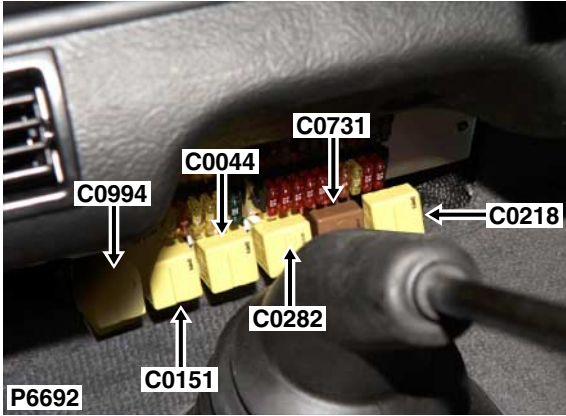

Cav	Col	Cct
30	WB	ALL
85	B	ALL
86	WB	ALL
87	NO	ALL

Description: *Relay - Heated rear screen*
 Location: *Behind centre of fascia*

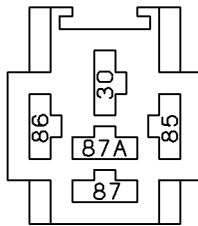

AFU3271

Colour: *YELLOW*
 Gender: *Female*

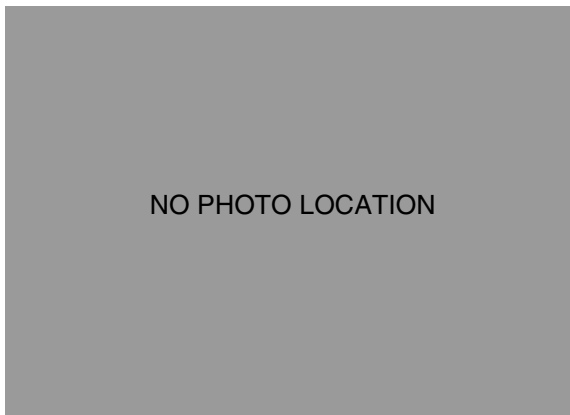

Cav	Col	Cct
1	WG	22
2	UR	22
4	NG	22
5	U	22
6	B	22
7	RO	22
8	UR	22

Description: *Relay - Dim dip*

Location: *Behind RH side of fascia*

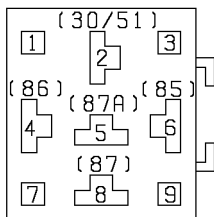

AFU4177

Colour: *BLACK*

Gender: *Female*

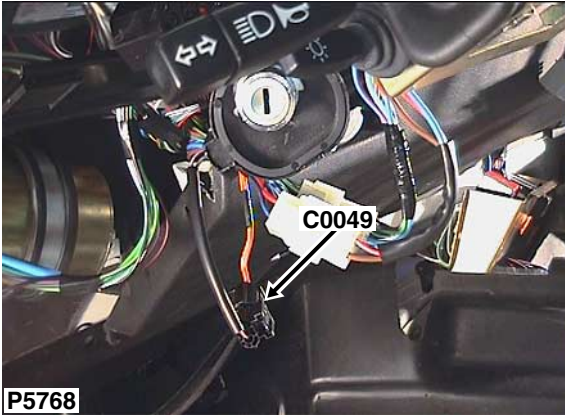

Cav	Col	Cct
1	OG	21
2	OP	21

Description: *Coil - Transponder*

Location: *Behind steering column cowl LH side*

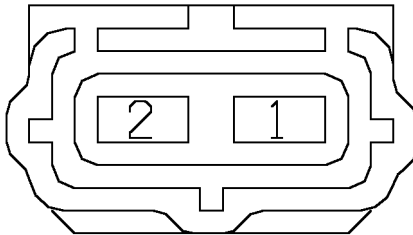

YPC10069

Colour: *BLACK*

Gender: *Female*

C0056

CONNECTOR DETAILS

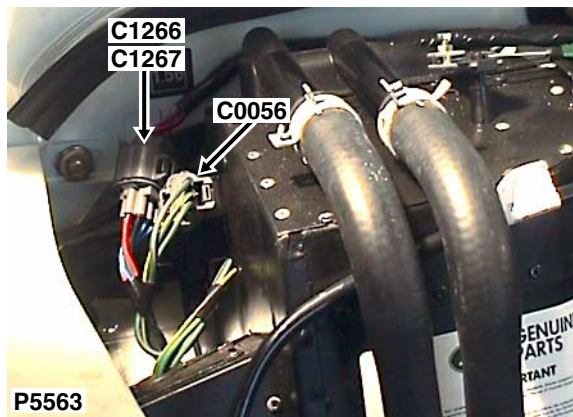

Cav	Col	Cct
1	GS	3
2	GY	3
3	PG	3

Description: *Motor - Blower*

Location: *Adjacent heater assembly*

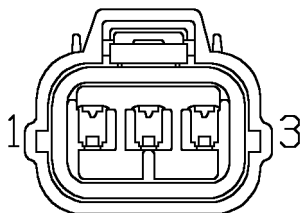

YPC10181

Colour: *LIGHT GREY*

Gender: *Female*

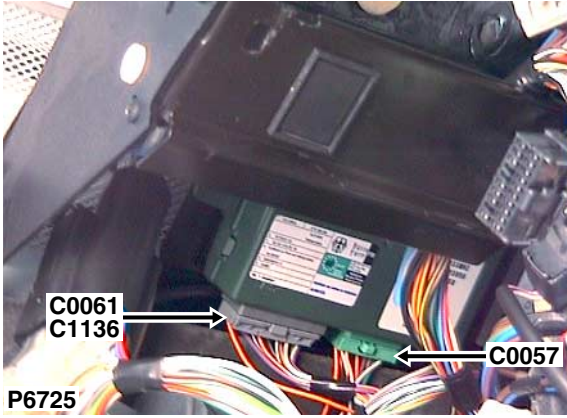

Cav	Col	Cct
1	GW	21
2	O	21
3	K	21
4	K	21
5	OW	21
6	GR	21
7	OG	21
8	PN	21
9	O	21
10	BO	21
11	B	21
12	OP	21

Description: *ECU - Alarm*
 Location: *Behind instrument pack*

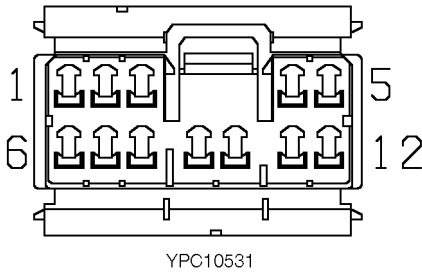

Colour: *GREEN*
 Gender: *Female*

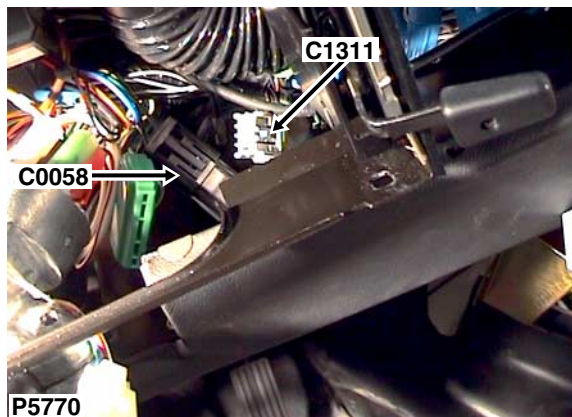

Cav	Col	Cct
1	GS	3
2	GY	3
3	B	3

Description: *Switch - Blower motor*

Location: *Behind instrument pack*

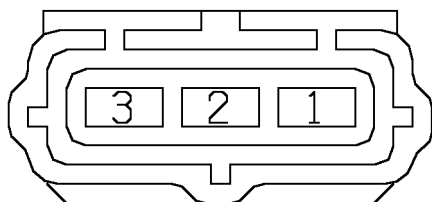

YPC10067

Colour: *BLACK*

Gender: *Female*

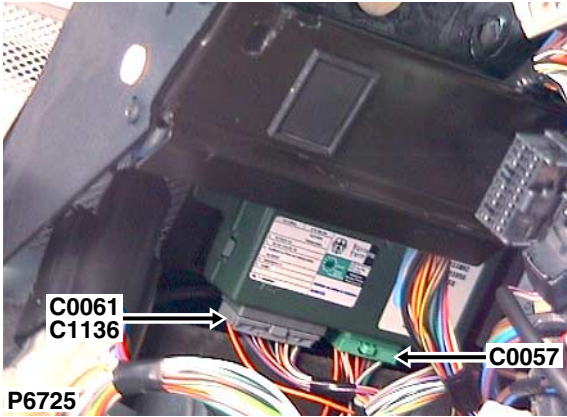

Description: *ECU - Alarm*
 Location: *Behind instrument pack*

Cav	Col	Cct
1	PW	21
3	WB	21
5	SW	21
7	YK	21
9	OU	21
10	WG	21
14	LGS	ALL
16	PU	21
17	OLG	21
20	BN	21
25	PN	21
26	OS	21

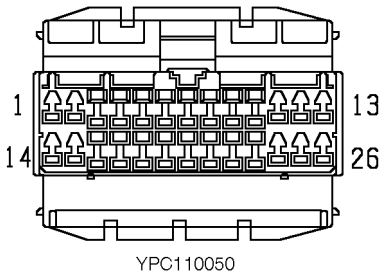

Colour: *GREY*
 Gender: *Female*

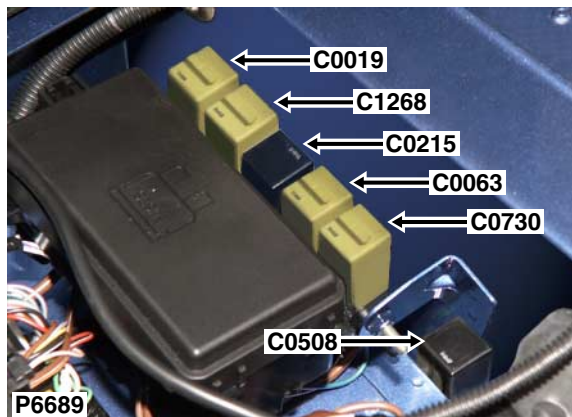

Cav	Col	Cct
30	NLG	4
85	N	4
86	UR	4
87	NO	4

Description: *Relay - main*

Location: *Beneath RH seat*

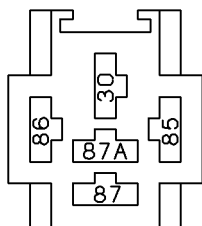

AFU3271

Colour: *YELLOW*

Gender: *Female*

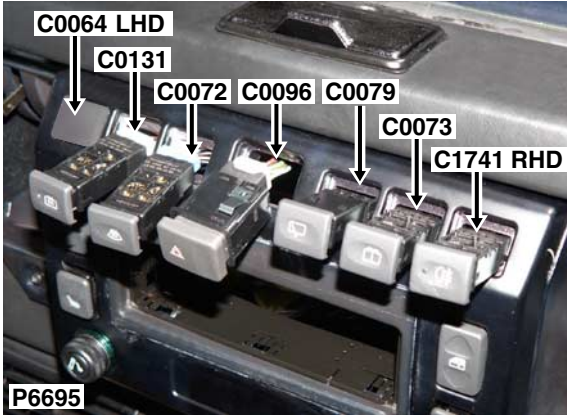

Cav	Col	Cct
1	BS	2
2	RO	2
4	B	2
5	RY	2

Description: *Switch - Fog guard lamp - Rear*
 Location: *Fascia - top centre*

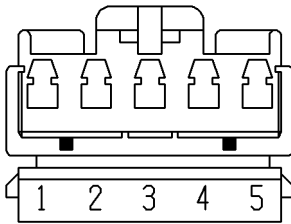

YPC10523

Colour: *BLACK*
 Gender: *Female*

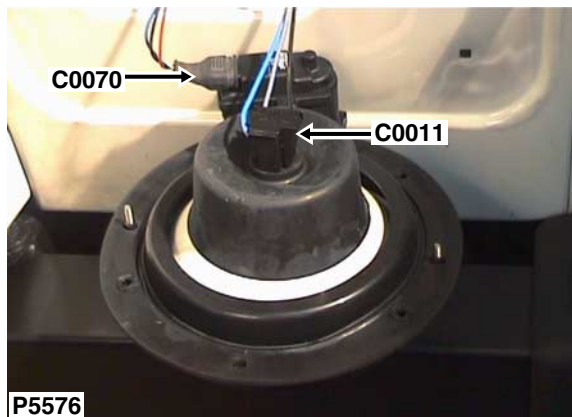

Description: *Motor - Headlamp levelling - RH*

Location: *Behind RH headlamp*

Cav	Col	Cct
1	UY	37
2	B	37
3	RO	37

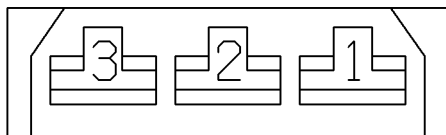

YPC10426

Colour: *NATURAL*

Gender: *Female*

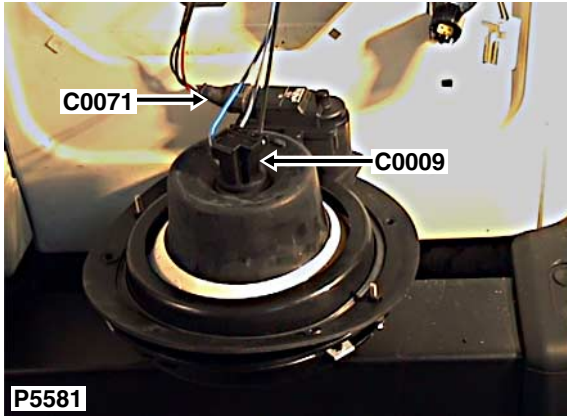

Cav	Col	Cct
1	UY	37
2	B	37
3	RO	37

Description: *Motor - Headlamp levelling - LH*
 Location: *Behind LH headlamp*

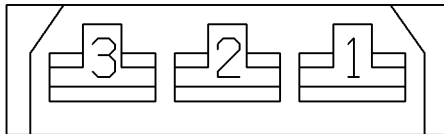

YPC10426

Colour: *NATURAL*
 Gender: *Female*

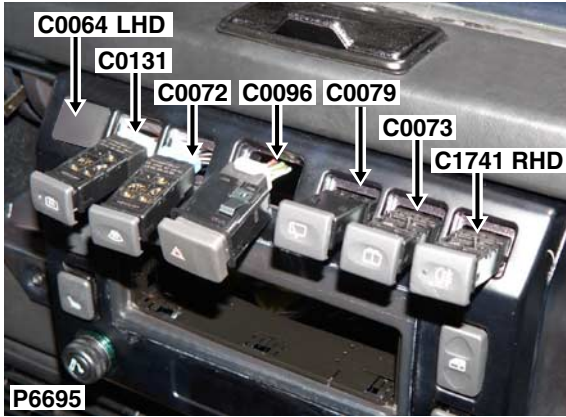

Description: *Switch - Heated rear screen*

Location: *Fascia - top centre*

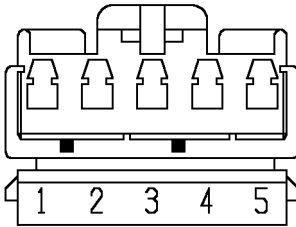

YPC10525

Colour: *BLUE*
 Gender: *Female*

Cav	Col	Cct
1	WG	ALL
2	RO	ALL
4	WB	ALL
5	B	ALL

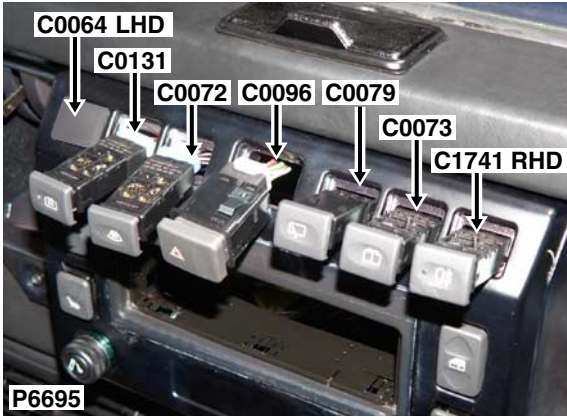

Cav	Col	Cct
1	WG	ALL
2	B	ALL
4	BLG	ALL
5	RO	ALL

Description: *Switch - Washer - Rear screen*
 Location: *Fascia - top centre*

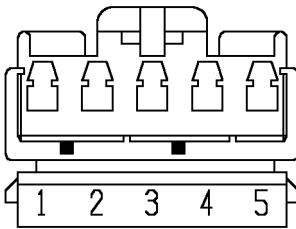

YPC10525

Colour: *BLUE*
 Gender: *Female*

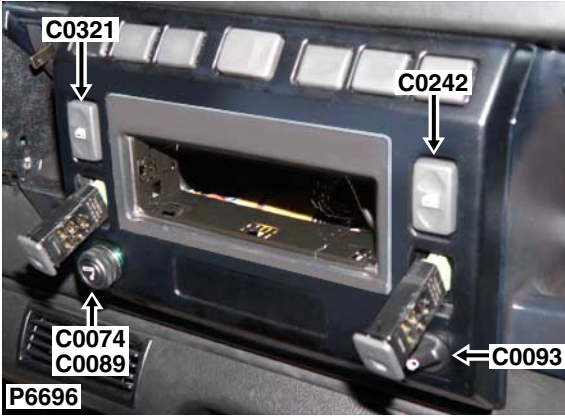

Cav	Col	Cct
1	RO	ALL

Description: *Cigar lighter illumination*
Location: *Fascia - top centre*

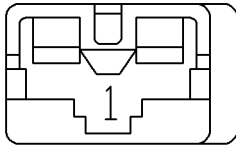

AFU4521

Colour: *NATURAL*
Gender: *Female*

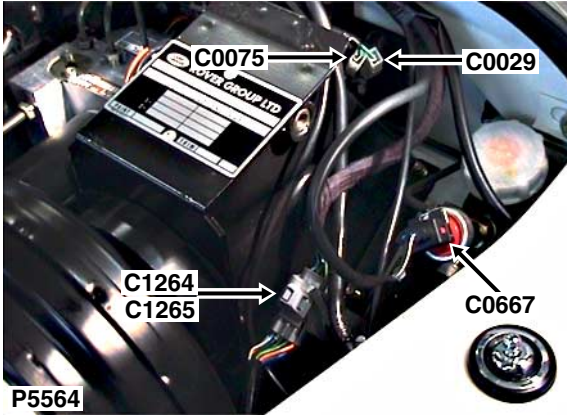

Cav	Col	Cct
1	GO	3

Description: *Switch - Brake pedal*
 Location: *Rear LH side of engine compartment*

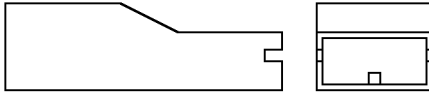

ADU8339

Colour: *NATURAL*
 Gender: *Female*

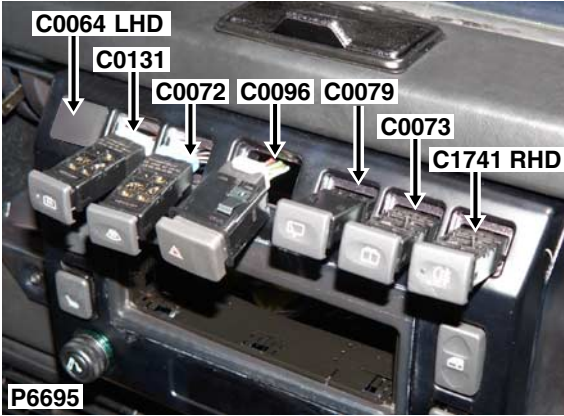

Description: *Switch - Wiper - Rear*

Location: *Fascia - top centre*

Cav	Col	Cct
1	BG	ALL
2	RO	ALL
4	B	ALL

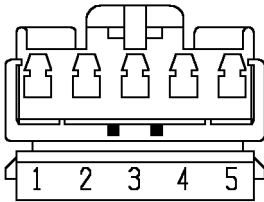

YPC10524

Colour: *WHITE*

Gender: *Female*



Cav	Col	Cct
1	B	ALL
2	PG	ALL

Description: *Cigar lighter*

Location: *Fascia - top centre*

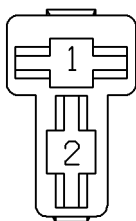

YPC 109020

Colour: *RED*
 Gender: *Female*

Cav	Col	Cct
1	WR	3

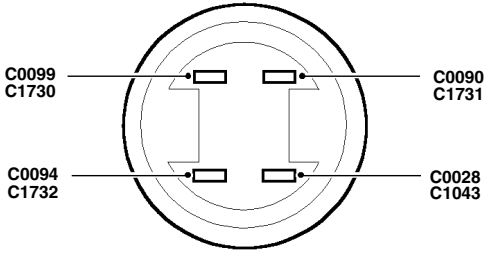

Description: *Switch - Ignition*

Location: *Behind instrument pack*

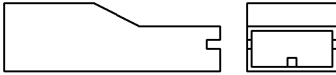

YPC10245

Colour: *RED*

Gender: *Female*

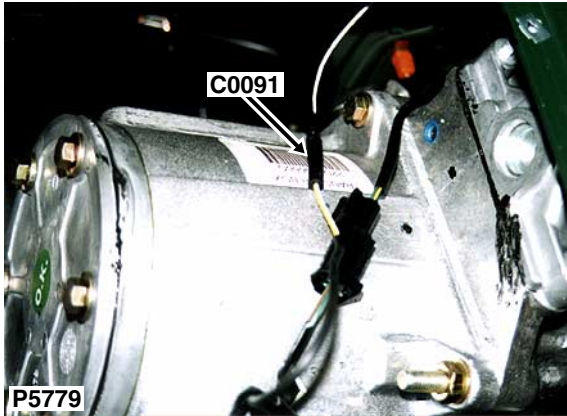

Cav	Col	Cct
1	WY	ALL

Description: *Switch - Handbrake*

Location: *Base of handbrake lever*

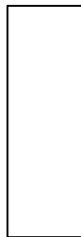

13H5155

Colour: *BLACK*

Gender: *Female*

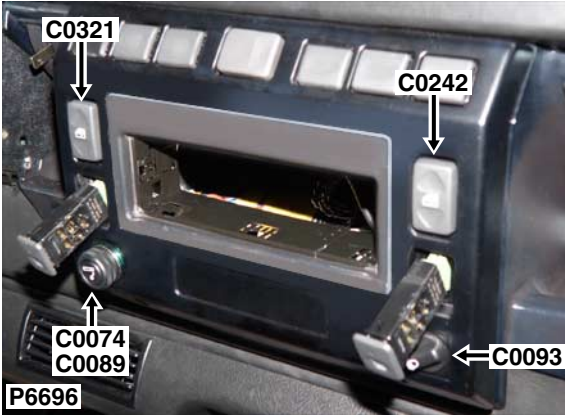

Cav	Col	Cct
2	UY	40
3	B	40
4	RO	40
5	RO	40

Description: *Switch - Headlamp levelling*

Location: *Fascia - top centre*

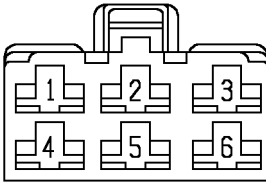

YPC10004

Colour: *NATURAL*

Gender: *Female*

Cav	Col	Cct
1	W	ALL

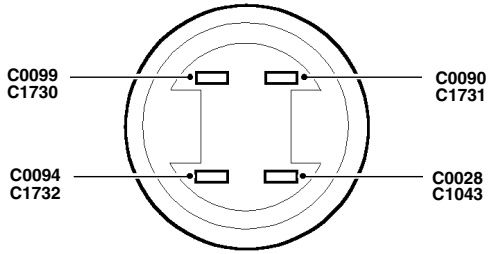

Description: *Switch - Ignition*
 Location: *Behind instrument pack*

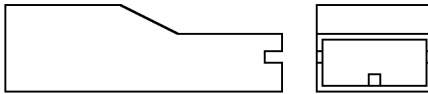

ADU8339

Colour: *NATURAL*
 Gender: *Female*

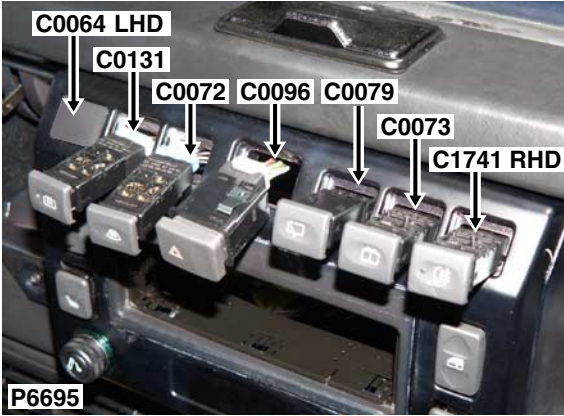

Description: *Switch - Hazard warning*

Location: *Fascia - top centre*

Cav	Col	Cct
1	WG	ALL
2	PN	ALL
3	LG	ALL
4	RO	ALL
5	B	ALL
6	LGN	ALL
7	GR	ALL
8	BR	ALL
9	GW	ALL

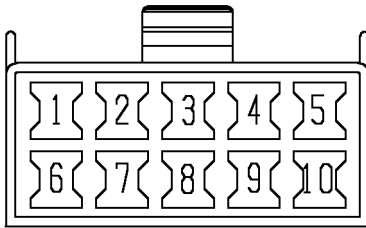

AFU3731

Colour: *NATURAL*

Gender: *Female*

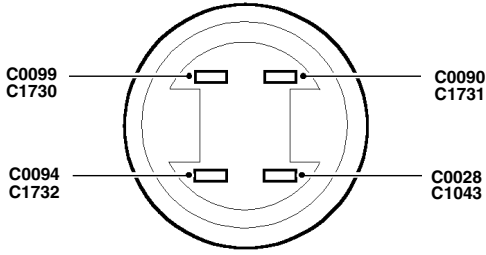

Cav	Col	Cct
1	WO	3

Description: *Switch - Ignition*
 Location: *Behind instrument pack*

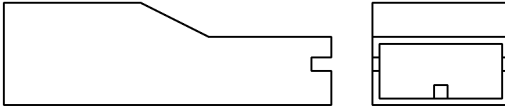

YPC115690

Colour: *GREEN*
 Gender: *Female*



Cav	Col	Cct
1	PU	ALL

Description: *Switch - Door - Rear - LH*

Location: *Base of 'C' post - LH side*

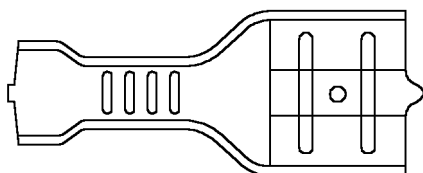

AFU3262

Colour: *BRASS, TIN-PLATED*

Gender: *Female*



Cav	Col	Cct
1	PU	21
1	PW	30

P6724

Description: *Switch - Door - LH*

Location: *LH 'A' post*

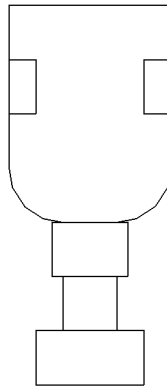

ADU9566

Colour: *BRASS, TIN-PLATED*

Gender: *Female*



Cav	Col	Cct
1	PU	ALL

Description: *Switch - Door - Rear - RH*

Location: *Base of 'C' post RH side*

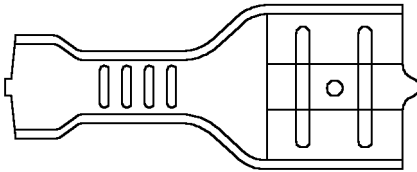

AFU3262

Colour: *BRASS, TIN-PLATED*

Gender: *Female*

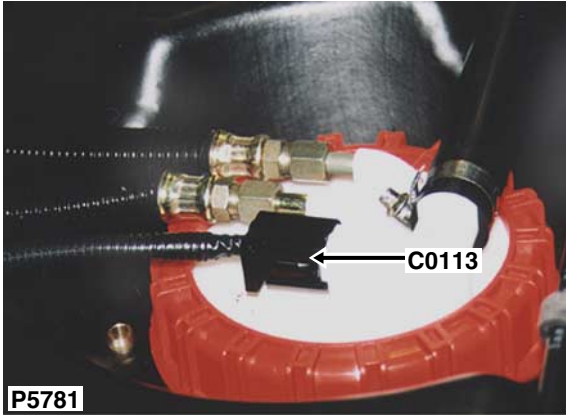

Cav	Col	Cct
1	GB	12
2	SB	12
3	B	12

Description: *Fuel tank*

Location: *Above fuel tank*

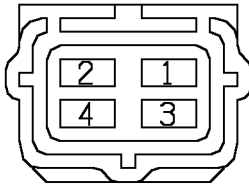

YPC10066

Colour: *BLACK*

Gender: *Female*

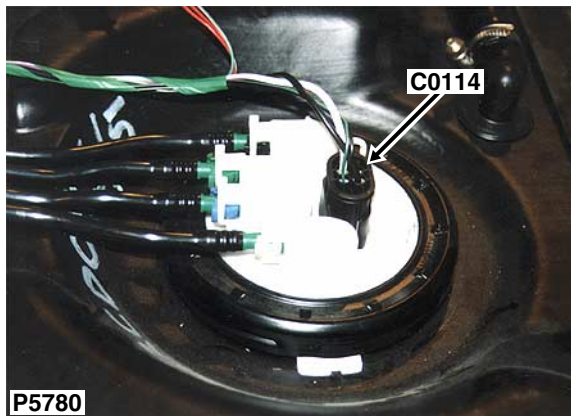

Cav	Col	Cct
1	WP	11
2	GB	11
3	SB	11
4	B	11

Description: *Fuel tank*

Location: *Above fuel tank*

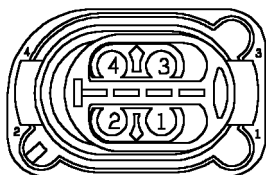

YPC110200

Colour: *BLACK*

Gender: *Female*

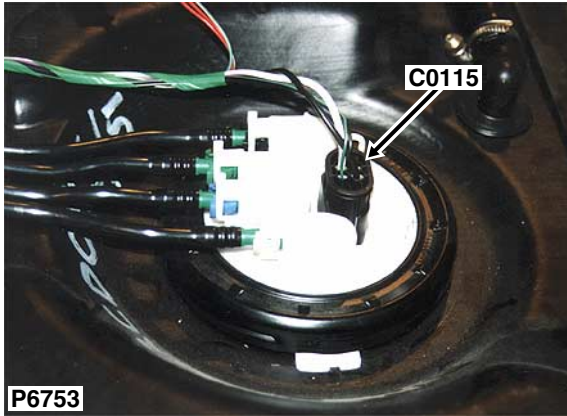

Cav	Col	Cct
1	WP	14
2	GB	14
3	SB	14
4	B	14

Description: *Fuel tank*

Location: *Above fuel tank*

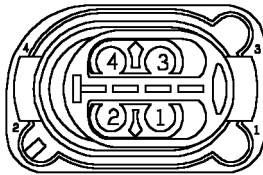

YPC110200

Colour: *BLACK*

Gender: *Female*

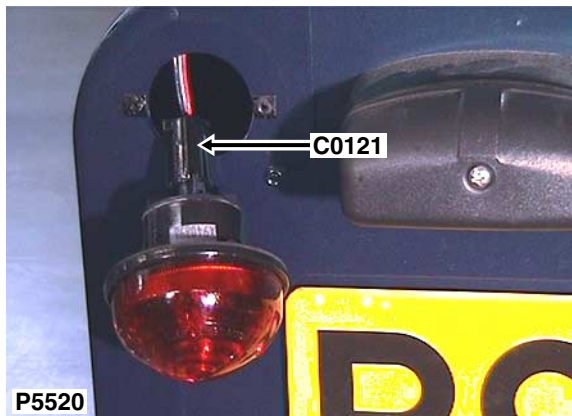

P5520

Description: *Lamp - Tail - LH*

Location: *LH rear of vehicle*

Cav	Col	Cct
1	B	ALL
2	GP	ALL
3	RB	ALL

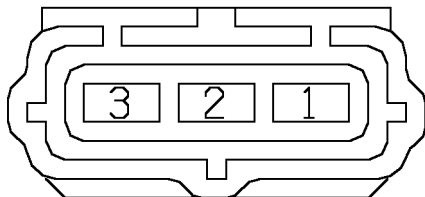

YPC10068

Colour: *BLACK*

Gender: *Female*

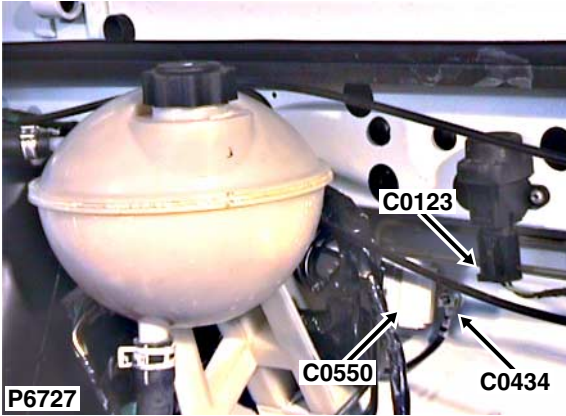

Cav	Col	Cct
1	NLG	4
3	N	4

Description: *Switch - Inertia*
Location: *Top of bulkhead - centre*

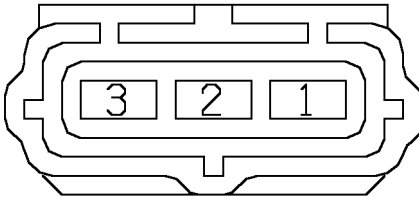

YPC10068

Colour: *BLACK*
Gender: *Female*

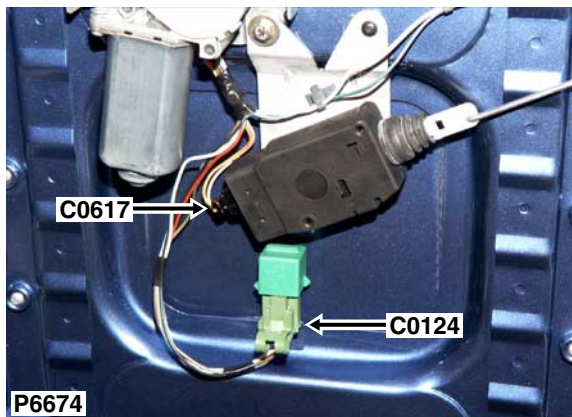

Cav	Col	Cct
2	RLG	1
4	BG	1
5	NLG	1
6	WG	1
8	WG	1

Description: *Relay - Rear wiper*

Location: *Centre of taildoor, behind trim panel*

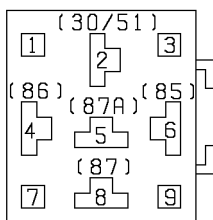

AFU4177

Colour: *BLACK*

Gender: *Female*

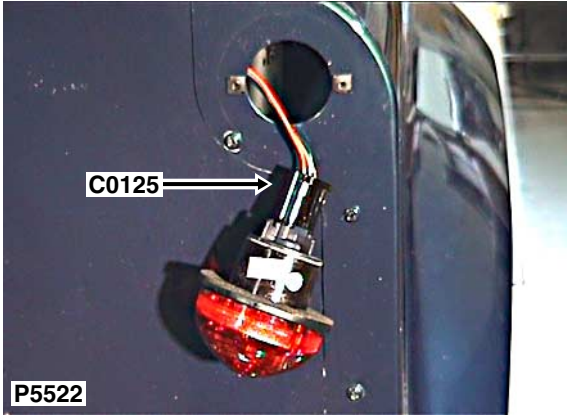

Cav	Col	Cct
1	B	ALL
2	GP	ALL
3	RO	ALL

Description: *Lamp - Tail - RH*
 Location: *RH rear of vehicle*

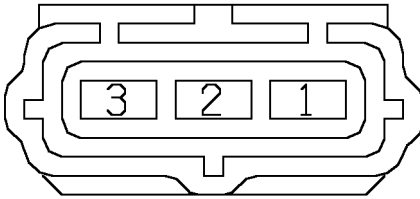

YPC10068

Colour: *BLACK*
 Gender: *Female*

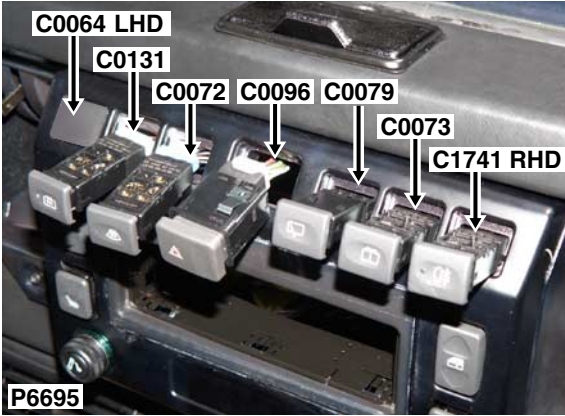

Description: *Switch - Heated front screen*

Location: *Fascia - top centre*

Cav	Col	Cct
1	KO	26
2	RO	26
4	B	26
5	PS	26

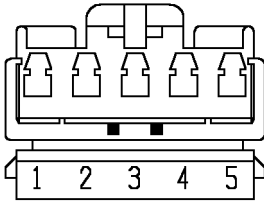

YPC10524

Colour: *WHITE*

Gender: *Female*

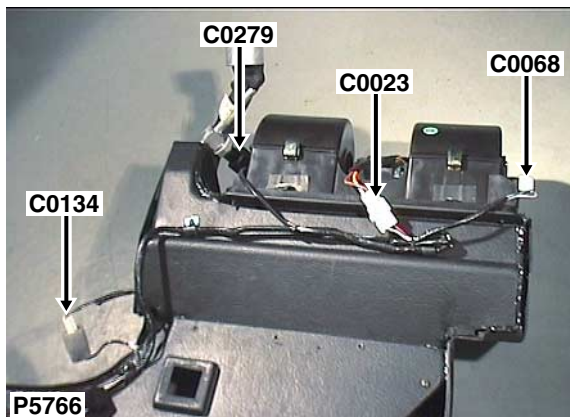

Cav	Col	Cct
1	K	ALL
2	UW	ALL

Description: *Sensor - Evaporator*

Location: *Behind RH side of fascia*

NO CONNECTOR FACE

Colour: *WHITE*

Gender: *Female*

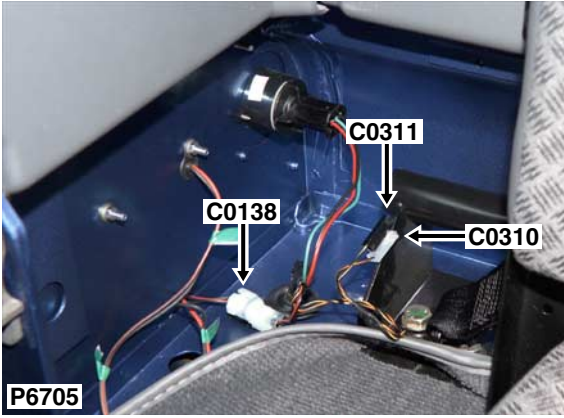

Cav	Col	Cct
1	RB	ALL
2	B	ALL

Description: *Lamp - Number plate*

Location: *Behind LH rear trim panel*

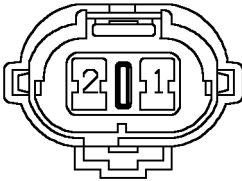

AFU3584

Colour: *NATURAL*

Gender: *Male*

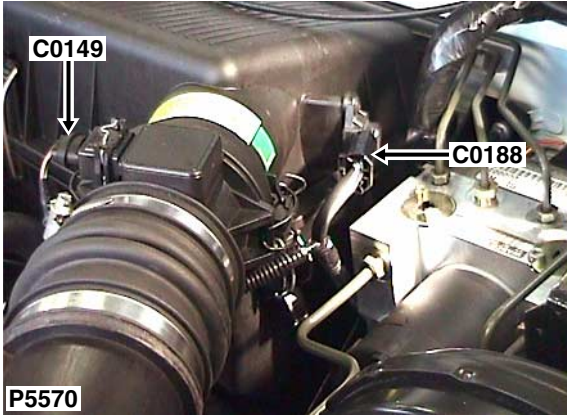

Cav	Col	Cct
1	KB	ALL
2	SLG	ALL
3	NO	ALL

Description: *Sensor - Mass air flow (MAF)*
Location: *Top of engine - RH side*

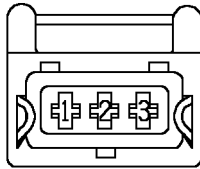

YPC114930

Colour: *BLACK*
Gender: *Female*

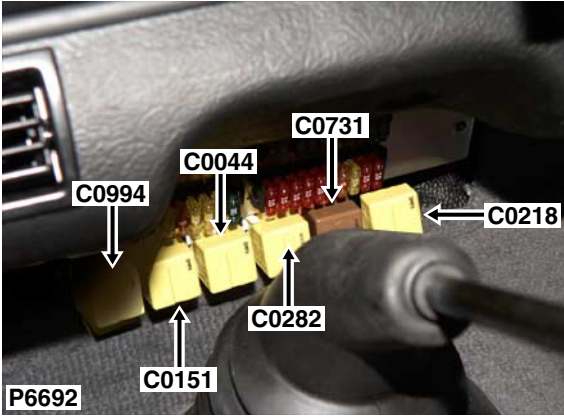

Description: *Relay - Starter*

Location: *Beneath centre console*

Cav	Col	Cct
30	NW	ALL
85	BO	ALL
85	B	ALL
86	WR	ALL
87	NR	ALL

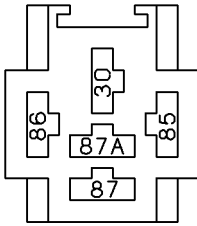

AFU3271

Colour: *YELLOW*

Gender: *Female*

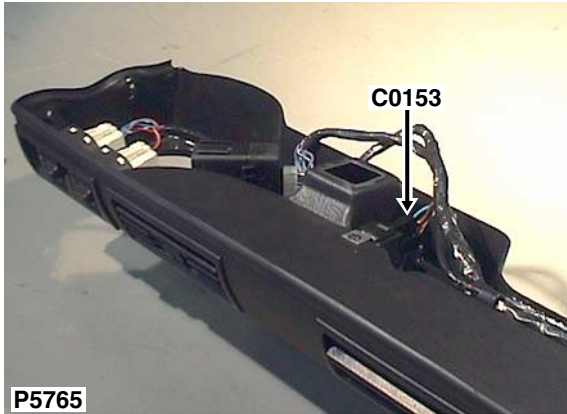

Cav	Col	Cct
1	N	ALL
2	UB	ALL
3	WG	ALL
4	UW	ALL

Description: *Relay - Blower*

Location: *Behind LH side of fascia*

NO CONNECTOR FACE

Colour: *BLACK*

Gender: *Female*

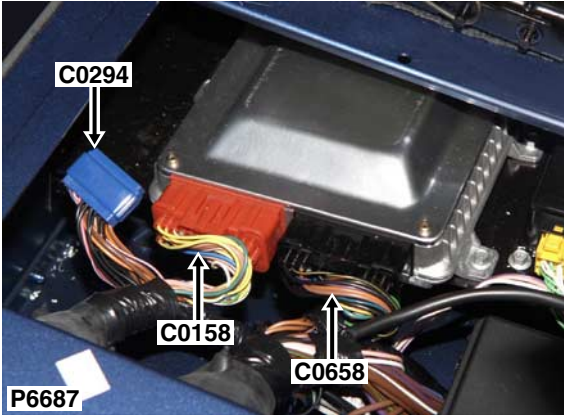

Description: *Engine control module (ECM)*

Location: *Beneath RH seat*

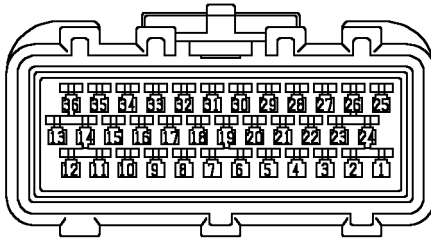

YPC10530

Colour: *RED*
 Gender: *Female*

Cav	Col	Cct
1	YP	ALL
3	U	46
4	O	46
5	KB	ALL
6	WY	ALL
7	KG	ALL
8	KP	ALL
10	WY	4
11	SLG	ALL
13	KB	ALL
16	SCR	ALL
17	KB	ALL
18	KB	ALL
19	YW	ALL
20	KB	ALL
22	NK	ALL
23	NO	ALL
24	YR	ALL
25	Y	ALL
26	YN	ALL
27	YU	ALL
29	GU	ALL
30	KB	4
31	GU	4
33	WB	ALL
34	GB	ALL
36	WU	ALL

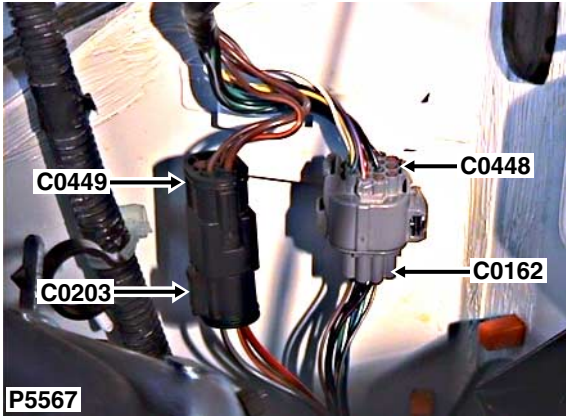

Description: *Engine harness to main harness*
 Location: *Lower RH rear of engine compartment*

Cav	Col	Cct
1	WN	ALL
2	NY	ALL
3	BU	ALL
4	GN	ALL
5	GY	ALL
6	B	ALL
7	SR	ALL
8	BS	25
9	BP	25
10	BR	ALL
11	BY	ALL
12	B	ALL
12	WG	ALL
13	WG	7
13	B	ALL
14	GU	ALL

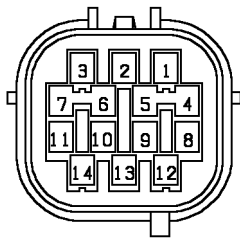

YPC10469

Colour: *GREY*
 Gender: *Male*

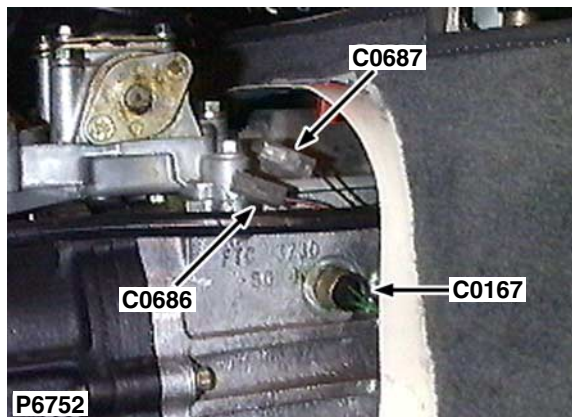

Cav	Col	Cct
1	GN	ALL
2	GY	ALL

Description: *Switch - Reverse lamp - 300 TDi*

Location: *LH side of gearbox*

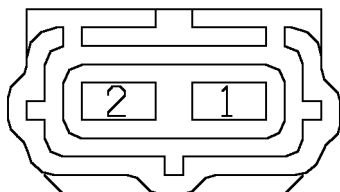

YPC10070

Colour: *BLACK*

Gender: *Female*

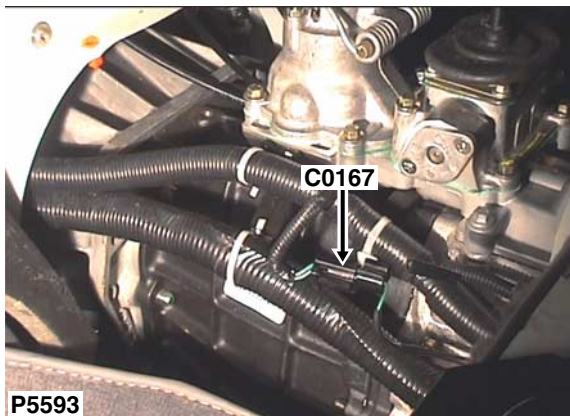

Cav	Col	Cct
1	GN	ALL
2	GY	ALL

P5593

Description: *Switch - Reverse lamp - Td5*

Location: *LH side of gearbox*

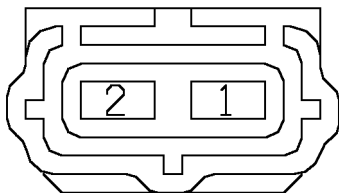

YPC10070

Colour: *BLACK*

Gender: *Female*

C0168

CONNECTOR DETAILS

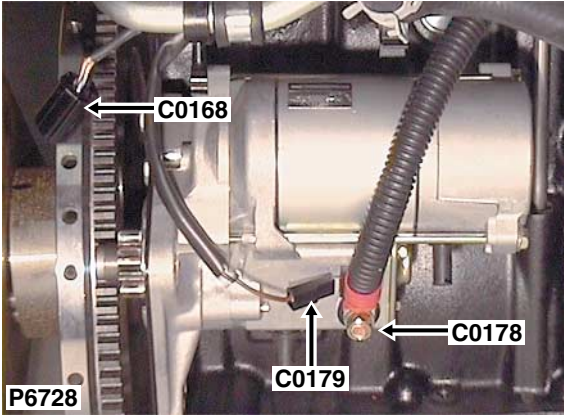

Cav	Col	Cct
SCR	SCR	ALL
1	KB	ALL
2	WU	ALL

Description: *Sensor - Crankshaft position (CKP)*

Location: *Lower RH rear of engine compartment*

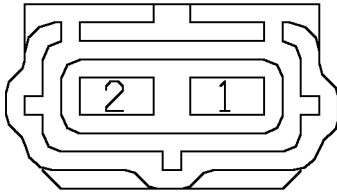

YPC10070

Colour: *BLACK*

Gender: *Female*



Cav	Col	Cct
1	GU	ALL

Description: *Sensor - Engine coolant temperature (ECT) - 300 TDi*
Location: *Front of engine - centre*

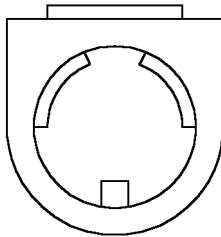

YPC10132

Colour: *NATURAL*
Gender: *Female*

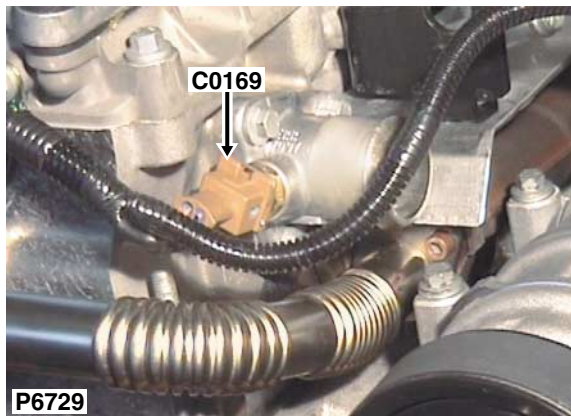

Cav	Col	Cct
1	KB	ALL
2	KG	ALL

Description: *Sensor - Engine coolant temperature (ECT) - Td5*

Location: *Front RH side of engine*

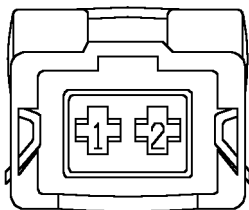

YPC107780

Colour: *BROWN*

Gender: *Female*

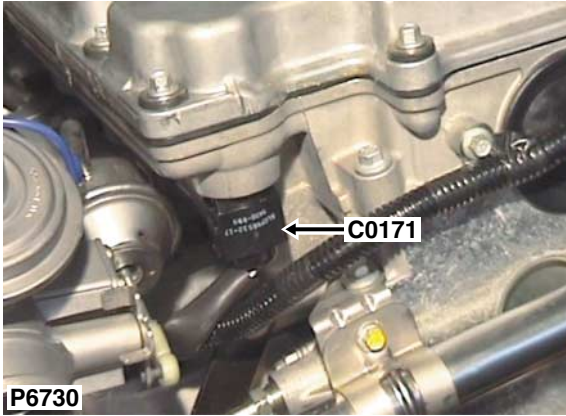

Cav	Col	Cct
1	Y	ALL
2	YN	ALL
4	YR	ALL
5	YP	ALL
6	YU	ALL
7	NO	ALL
8	NK	ALL

Description: *Engine harness to injector harness*
 Location: *Front LH side of engine*

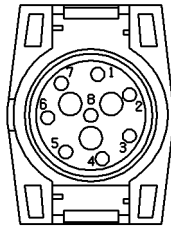

YYC10324

Colour: *BLACK*
 Gender: *Female*

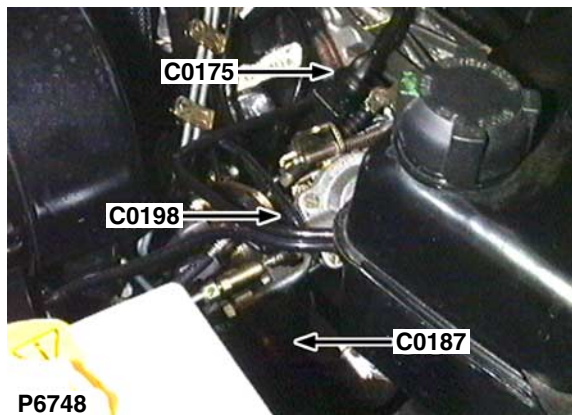

P6748

Description: *Sensor - Throttle position (TP)*

Location: *RH side of engine*

Cav	Col	Cct
1	KB	46
2	R	46
3	RB	46

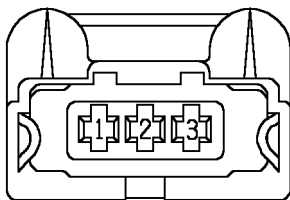

YPC107900

Colour: *BLACK*

Gender: *Female*

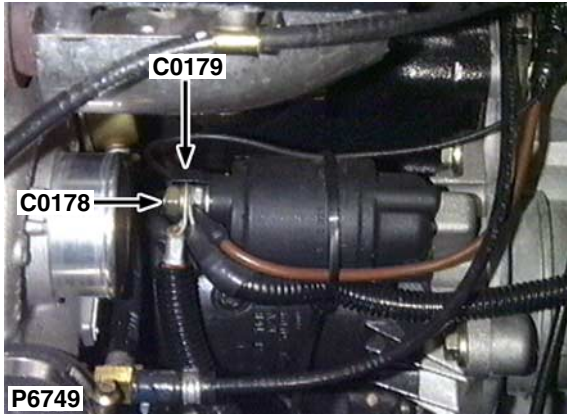

Cav	Col	Cct
1	N	ALL

Description: *Starter motor - 300 TDi*

Location: *LH side of engine*

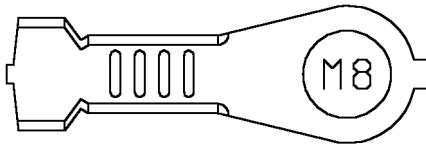

YPG10018

Colour: *TIN-PLATE*

Gender: *Eyelet*

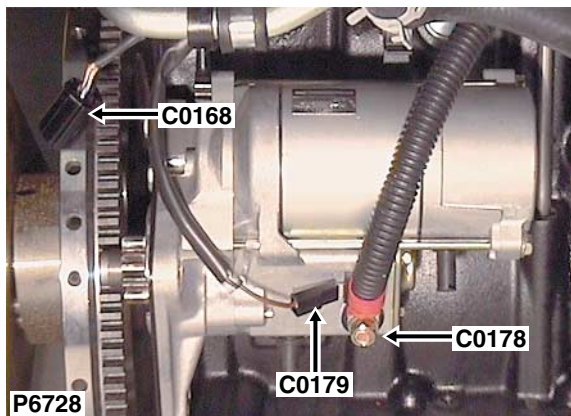

Cav	Col	Cct
1	N	ALL

Description: *Starter motor - Td5*

Location: *Rear RH side of engine*

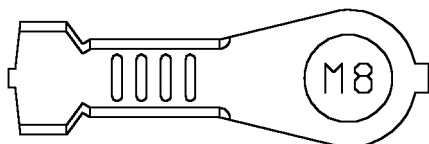

YPG10018

Colour: *TIN-PLATE*

Gender: *Eyelet*

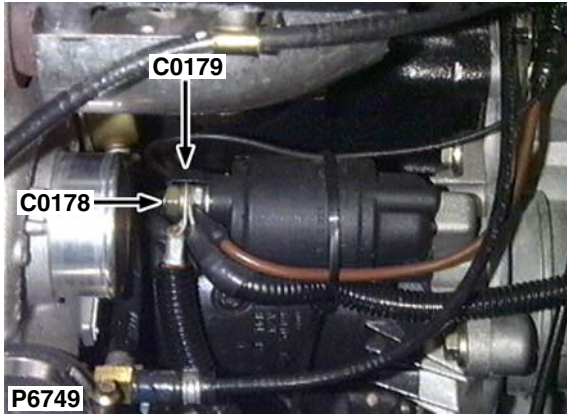

Cav	Col	Cct
1	NR	7
1	B	ALL

Description: *Solenoid - Starter motor - 300 TDi*

Location: *LH side of engine*

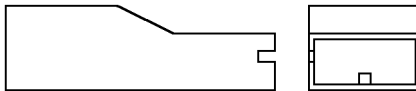

AAU1010

Colour: *BLACK*

Gender: *Female*

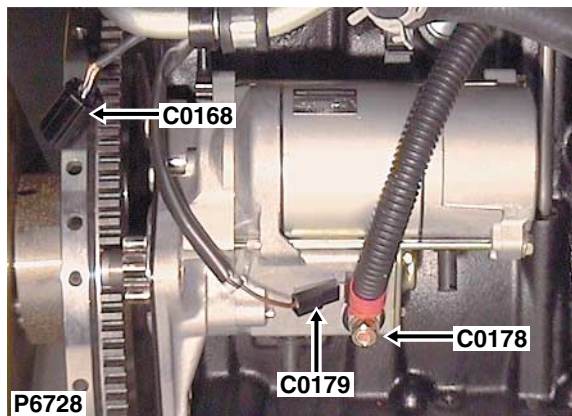

Cav	Col	Cct
1	NR	ALL

Description: *Solenoid - Starter motor - Td5*

Location: *Lower rear of engine - RH side*

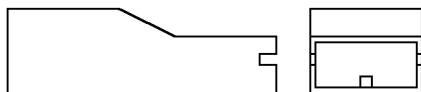

AAU1010

Colour: *BLACK*

Gender: *Female*

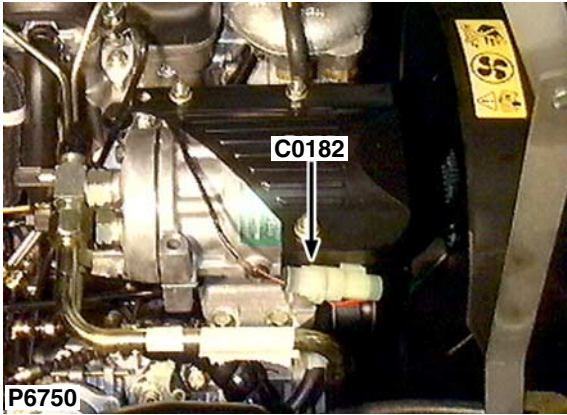

Cav	Col	Cct
1	BG	25
2	B	25

Description: *Clutch - Compressor - Air conditioning (A/C) - 300 TDi*
Location: *Front RH side of engine*

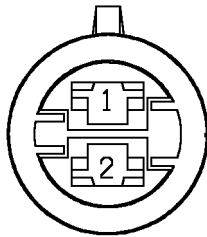

AFU3692

Colour: *NATURAL*
Gender: *Female*

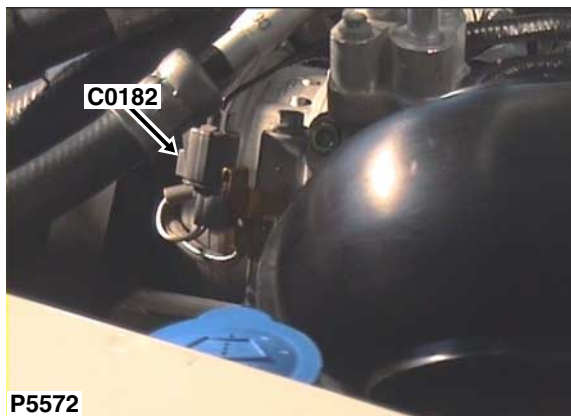

P5572

Description: *Clutch - Compressor - Air conditioning (A/C) - Td5*

Location: *Front RH side of engine*

Cav	Col	Cct
1	BG	25
2	B	25

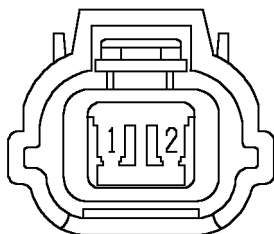

YPC10180

Colour: *GREY*

Gender: *Female*

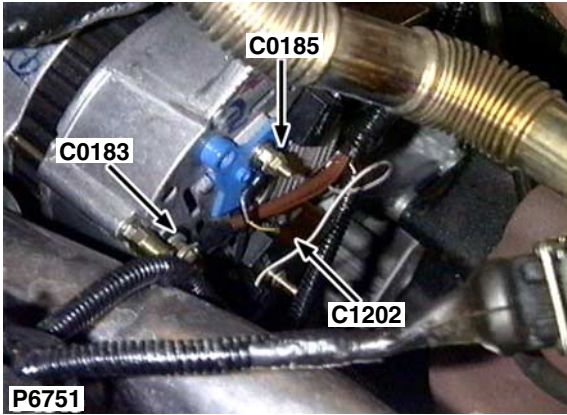

Cav	Col	Cct
1	N	ALL

Description: *Power - Alternator - 300 TDi*
Location: *Front LH side of engine*

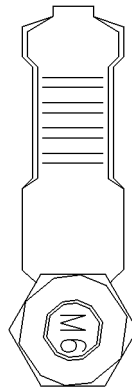

YPG10058

Colour: *BRASS, TIN-PLATED*
Gender: *Eyelet*

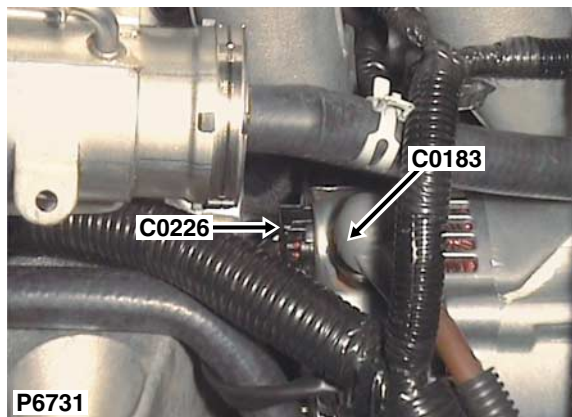

Cav	Col	Cct
1	N	ALL

Description: *Power - Alternator - Td5*

Location: *Front RH side of engine*

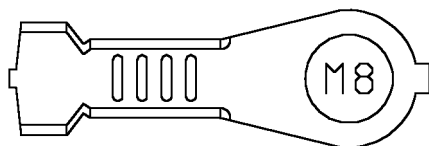

YPG10016

Colour: *BRASS*

Gender: *Eyelet*

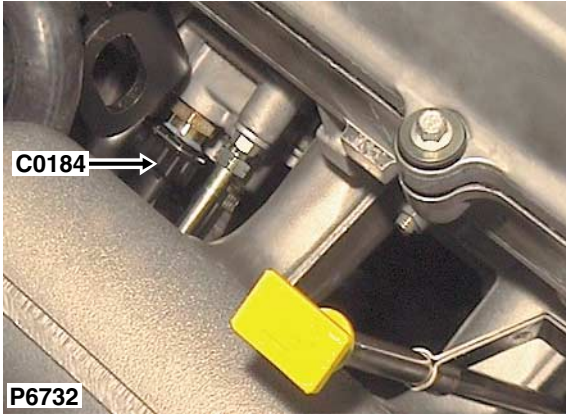

Cav	Col	Cct
1	KB	ALL
2	YW	ALL

Description: *Sensor - Temperature - Fuel rail*
Location: *Top of engine - RH side*

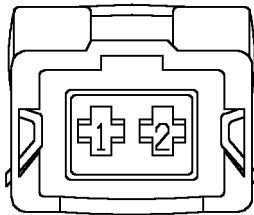

YPC107790

Colour: *BLACK*
Gender: *Female*

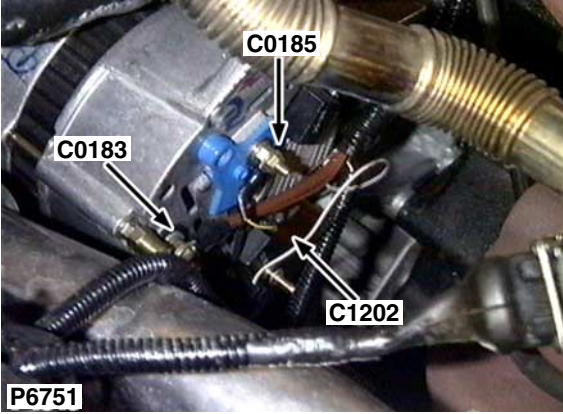

Cav	Col	Cct
1	NY	ALL

Description: *Warning lamp - Ignition / no charge*
Location: *LH side of engine*

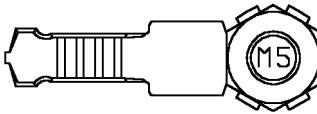

YPG100730

Colour: *BRASS*
Gender: *Female*

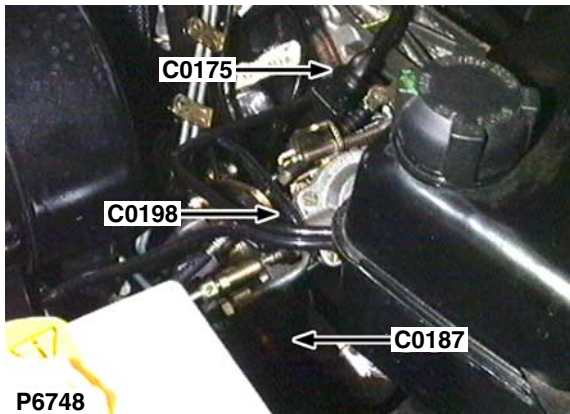

Cav	Col	Cct
1	WN	ALL

P6748

Description: *Switch - Oil pressure - 300 TDi*

Location: *RH side of engine*

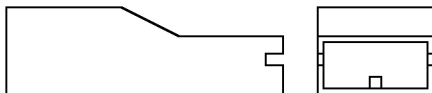

ADU8339

Colour: *NATURAL*

Gender: *Female*

C0187

CONNECTOR DETAILS

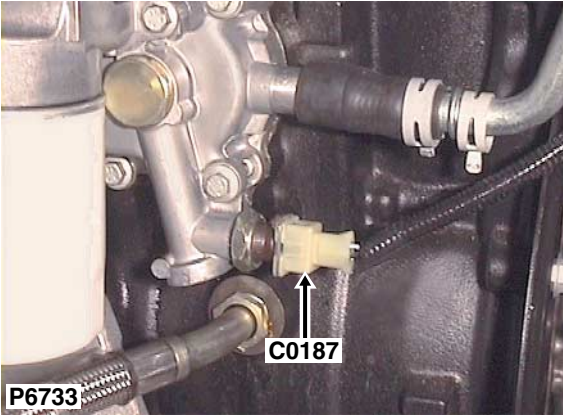

Cav	Col	Cct
1	WN	ALL

Description: *Switch - Oil pressure - Td5*
Location: *RH side of engine*

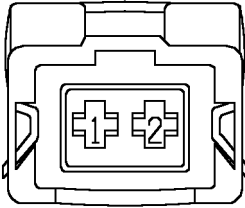

YPC107830

Colour: *NATURAL*
Gender: *Female*

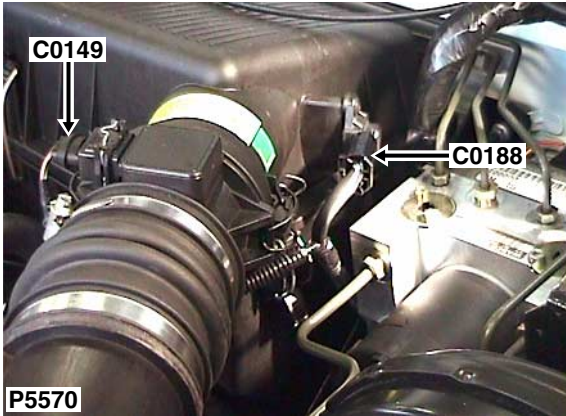

Cav	Col	Cct
1	KB	4
2	WY	4
3	KP	4

Description: *Sensor - Ambient Air Pressure (AAP)*
 Location: *Rear LH side of engine compartment*

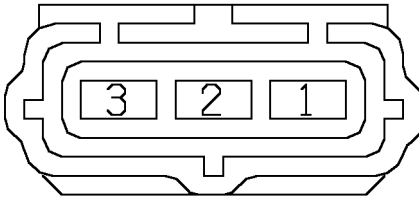

YPC10068

Colour: *BLACK*
 Gender: *Female*

C0191

CONNECTOR DETAILS

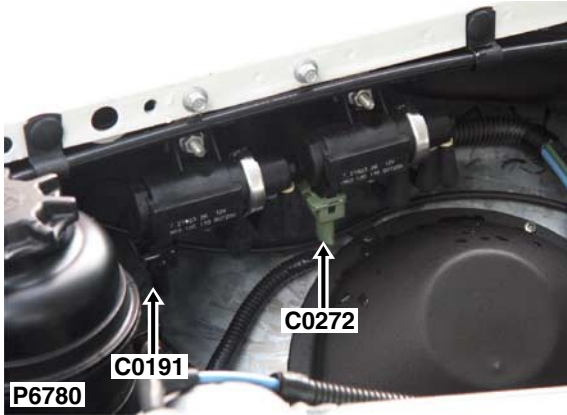

Cav	Col	Cct
1	NO	46
2	U	46

Description: *Modulator - EGR*

Location: *RH side of engine compartment*

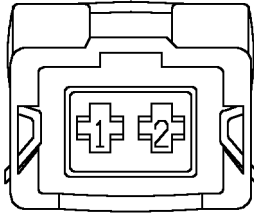

YPC107790

Colour: *BLACK*

Gender: *Female*

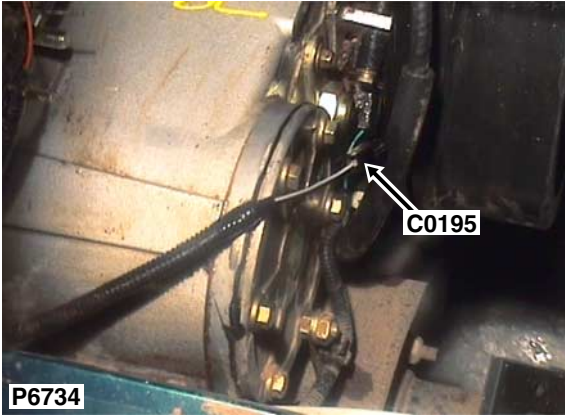

P6734

Description: *Speed transducer - Td5*

Location: *RH side of gearbox*

Cav	Col	Cct
1	WG	ALL
2	B	ALL
3	BR	ALL

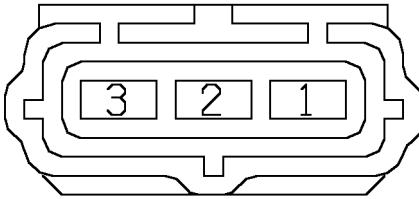

YPC10068

Colour: *BLACK*

Gender: *Female*

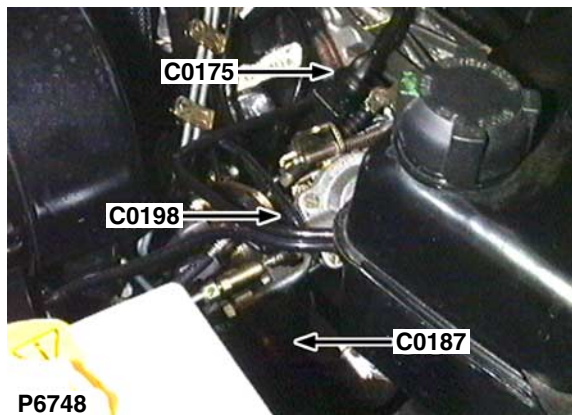

Cav	Col	Cct
1	WG	7
1	B	ALL

Description: *Solenoid - Fuel cut-off*
 Location: *RH side of engine*

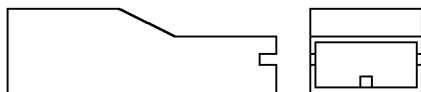

AAU1010

Colour: *BLACK*
 Gender: *Female*

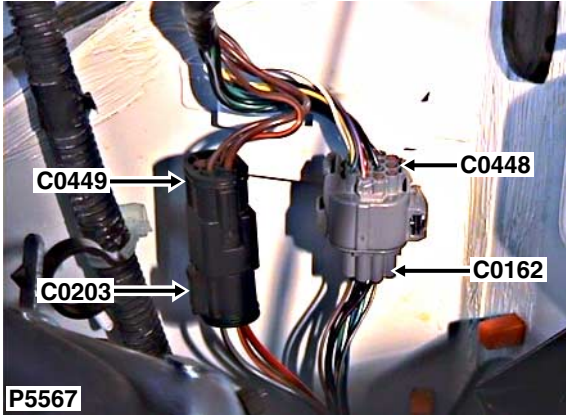

Cav	Col	Cct
1	B	ALL
1	NR	ALL
2	WG	25
2	NO	ALL
3	NS	25
4	WS	41

P5567

Description: *Engine harness to main harness*
 Location: *Lower RH rear of engine compartment*

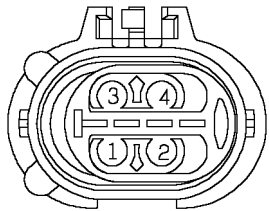

Colour: *BLACK*
 Gender: *Male*

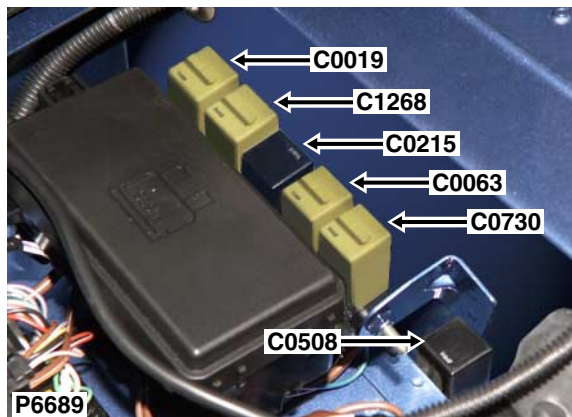

Cav	Col	Cct
1	N	ALL
2	NO	ALL
3	YB	ALL
4	GU	ALL

Description: *Relay - Glow plug*

Location: *Beneath RH seat*

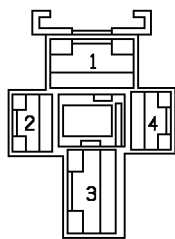

YPP10005

Colour: *BLACK*

Gender: *Female*

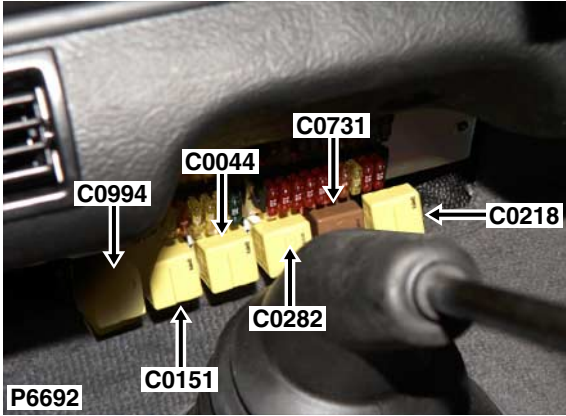

Cav	Col	Cct
30	NR	27
85	WG	27
86	B	27
87	NS	27

Description: *Relay - Window lift*
 Location: *Behind centre of fascia*

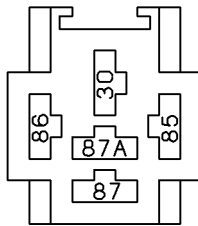

AFU3271

Colour: *YELLOW*
 Gender: *Female*

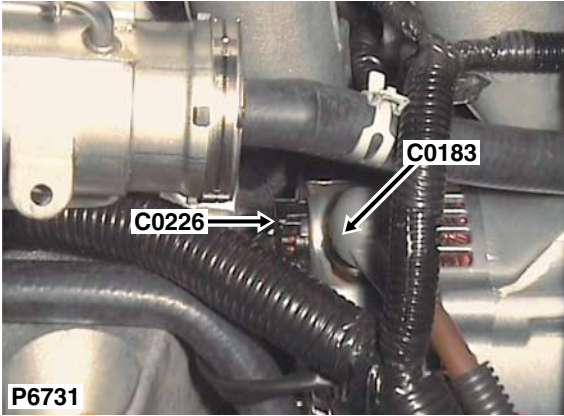

Cav	Col	Cct
1	NY	ALL
2	WG	ALL

Description: *Alternator / generator*
Location: *Front RH side of engine*

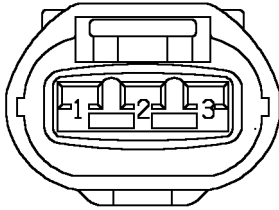

YPC10604

Colour: *BLACK*
Gender: *Female*

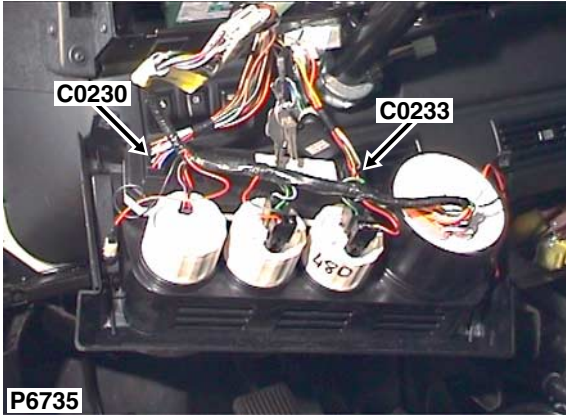

Cav	Col	Cct
1	WG	3
4	OG	6
5	SR	3
6	RS	9
7	RS	6
8	B	3
9	BW	9
10	RS	9
13	BW	9
14	BW	3
16	YS	6

Description: *Instrument Pack*
 Location: *Behind instrument pack*

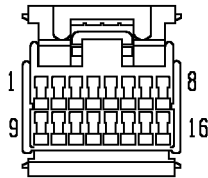

YPC10174

Colour: *BLACK*
 Gender: *Female*

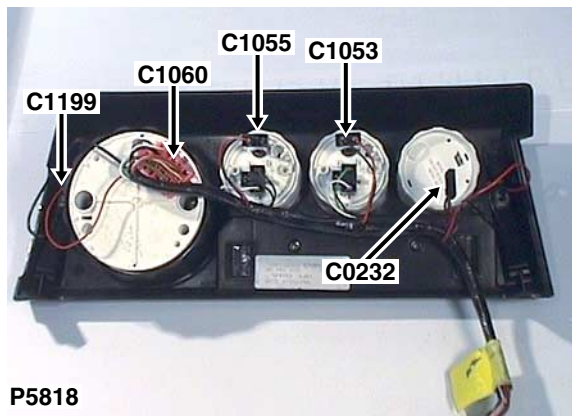

P5818

Description: *Clock - Analogue*

Location: *Behind instrument pack*

Cav	Col	Cct
1	RO	1
2	B	1
3	PN	1

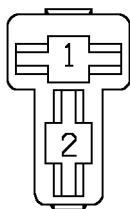

YPC109010

Colour: *BLACK*

Gender: *Female*

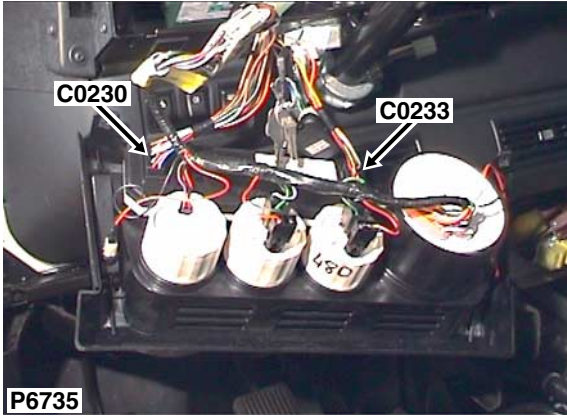

Description: *Instrument Pack*
 Location: *Behind instrument pack*

Cav	Col	Cct
1	UW	3
2	GW	3
3	WO	3
4	RY	3
5	O	21
7	BU	3
8	WB	3
9	BR	3
10	LGP	3
11	RS	6
12	BY	ALL
13	WN	ALL
16	WG	3
17	NY	3
18	GR	3
20	RB	3

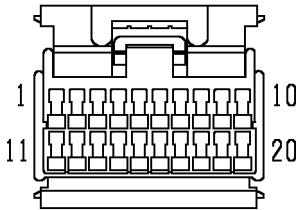

YPC10175

Colour: *BLACK*
 Gender: *Female*

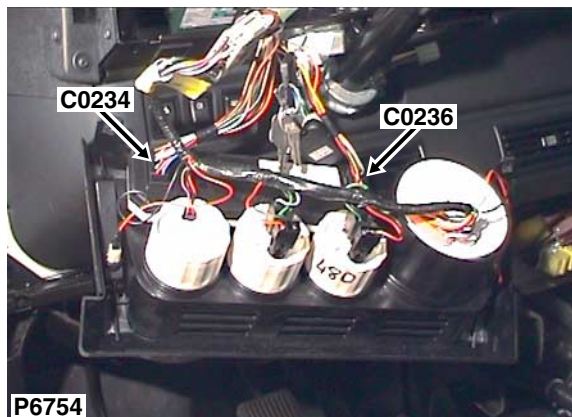

Description: *Instrument Pack*

Location: *Behind instrument pack*

Cav	Col	Cct
1	WG	2
4	OG	5
5	SR	2
6	RS	8
7	RS	5
8	B	2
9	BW	8
10	RS	8
13	BW	8
14	BW	2
16	YS	5

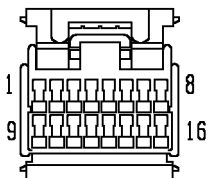

YPC10174

Colour: *BLACK*

Gender: *Female*

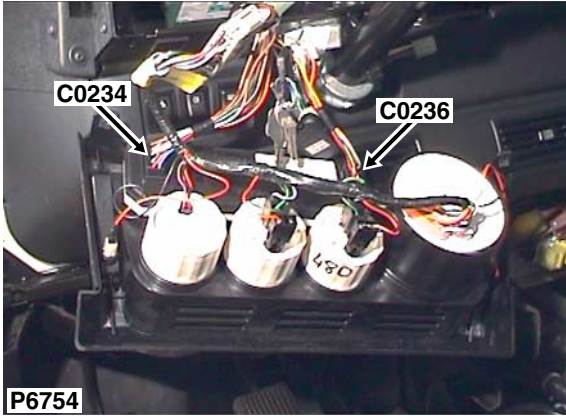

Description: *Instrument Pack*
 Location: *Behind instrument pack*

Cav	Col	Cct
1	UW	2
2	GW	2
3	WO	2
4	RY	2
5	O	20
6	BK	2
7	BU	2
8	WB	2
9	BR	2
10	LGP	2
11	RS	5
12	BY	ALL
13	WN	ALL
16	WG	2
17	NY	2
18	GR	2
20	RB	2

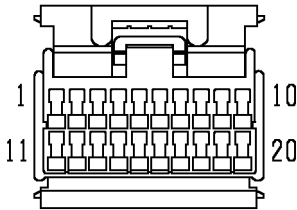

YPC10175

Colour: *BLACK*
 Gender: *Female*

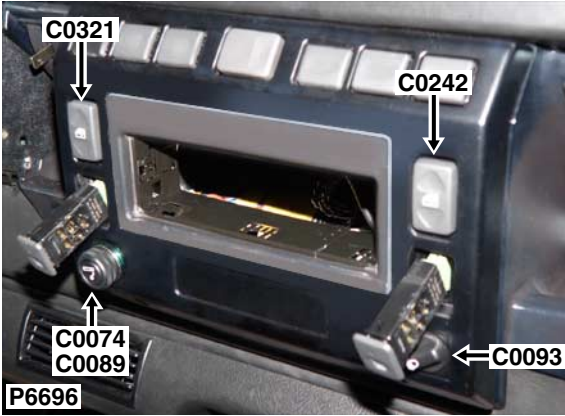

Cav	Col	Cct
1	B	27
2	SO	27
3	OU	ALL
4	OR	ALL
6	RO	ALL

Description: *Switch - Window - Front - RH*

Location: *Behind centre of fascia*

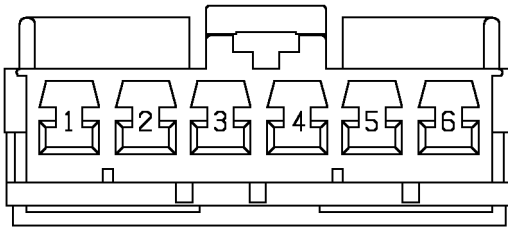

YPC113220

Colour: *WHITE*

Gender: *Female*



Cav	Col	Cct
1	PS	26

P6714

Description: *Heated screen - Front*
 Location: *Behind LH side of fascia*

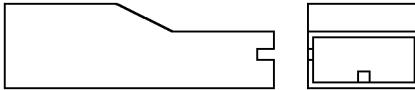

AAU1010

Colour: *BLACK*
 Gender: *Female*

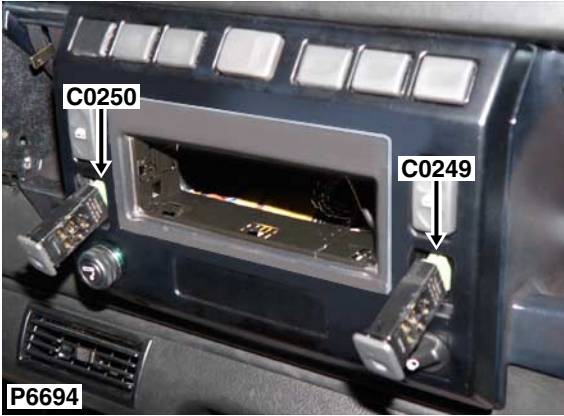

Cav	Col	Cct
1	LGW	26
2	RO	26
4	UK	26
5	B	26

Description: *Switch - Heater - Seat - RH*

Location: *Behind centre of fascia*

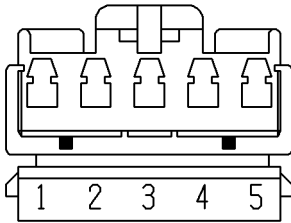

YPC10523

Colour: *GREEN*

Gender: *Female*

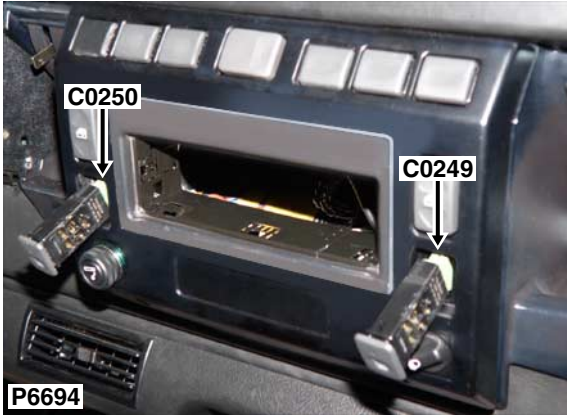

Cav	Col	Cct
1	LGW	26
2	RO	26
4	US	26
5	B	26

Description: *Switch - Heater - Seat - LH*
 Location: *Behind centre of fascia*

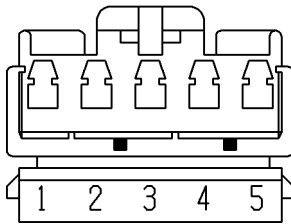

YPC 10526

Colour: *GREEN*
 Gender: *Female*

C0259

CONNECTOR DETAILS

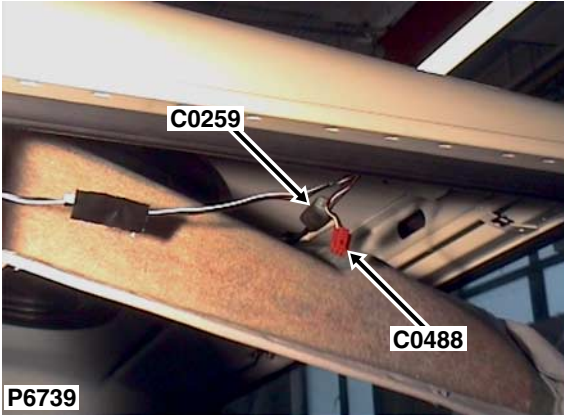

Cav	Col	Cct
1	B	ALL
2	PW	ALL
3	PN	ALL
4	PU	ALL
5	K	ALL
6	O	ALL
8	BN	ALL
9	B	ALL
10	WB	ALL

Description: Interior lamp harness to main harness

Location: Headlining - front RH side

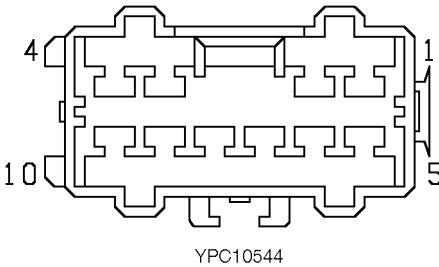

Colour: LIGHT GREY

Gender: Male

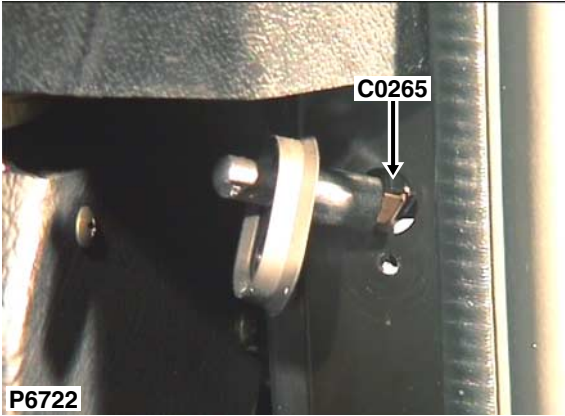

Cav	Col	Cct
1	PU	20
1	PW	30

Description: *Switch - Door - RH*
Location: *RH 'A' post*

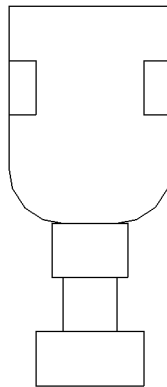

ADU9566

Colour: *BRASS, TIN-PLATED*
Gender: *Female*

**P6724**Description: *Switch - Door - LH*Location: *LH 'A' post*

Cav	Col	Cct
1	SW	20

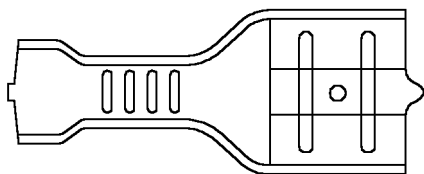

AFU3262

Colour: *BRASS, TIN-PLATED*Gender: *Female*



Cav	Col	Cct
1	G	46
2	BO	46

P6782

Description: *Modulator - EGR*

Location: *RH side of engine compartment*

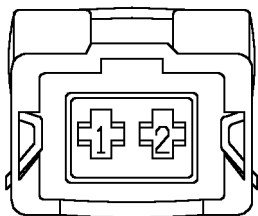

YPC107790

Colour: *BLACK*

Gender: *Female*

C0272

CONNECTOR DETAILS

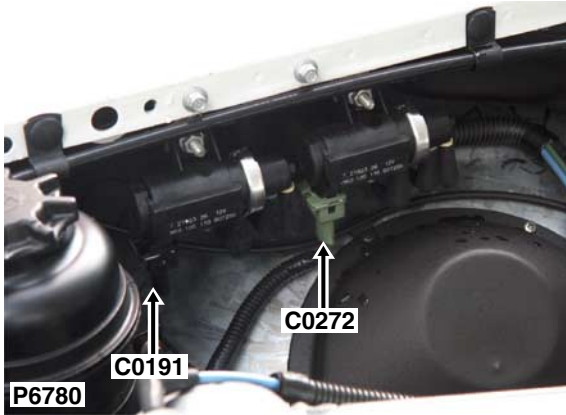

Cav	Col	Cct
1	NO	46
1	RB	46
2	KB	46
2	O	46
3	RU	46

Description: *Throttle - EGR - Inlet*

Location: *RH side of engine compartment*

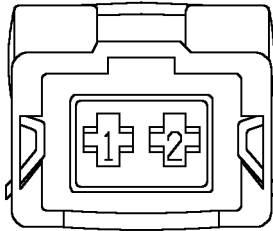

YPC107810

Colour: *GREEN*

Gender: *Female*

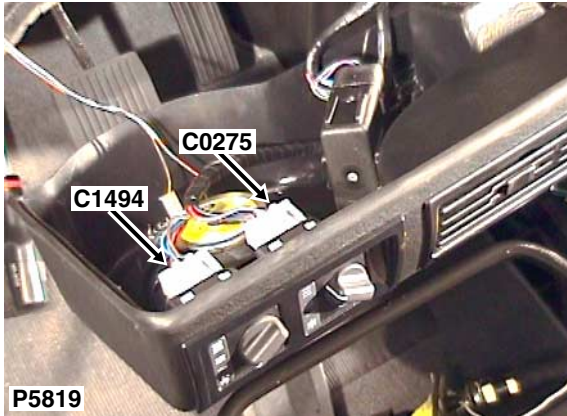

Cav	Col	Cct
2	RW	ALL
3	UB	ALL
4	WG	ALL
5	B	ALL
6	UY	ALL

Description: *Switch - Temperature control*

Location: *Behind LH side of fascia*

NO CONNECTOR FACE

Colour: *WHITE*

Gender: *Female*

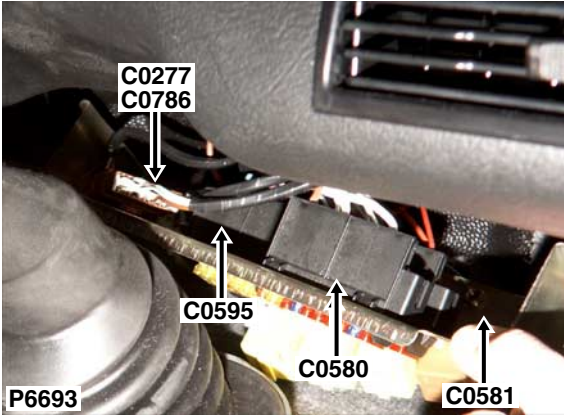

Cav	Col	Cct
1	WG	ALL
3	BS	ALL
4	WB	ALL
6	N	ALL
7	UB	ALL

Description: *Air conditioning (A/C) harness to main harness*

Location: *Beneath centre console*

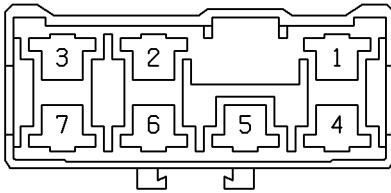

YPC10479

Colour: *BROWN*

Gender: *Male*

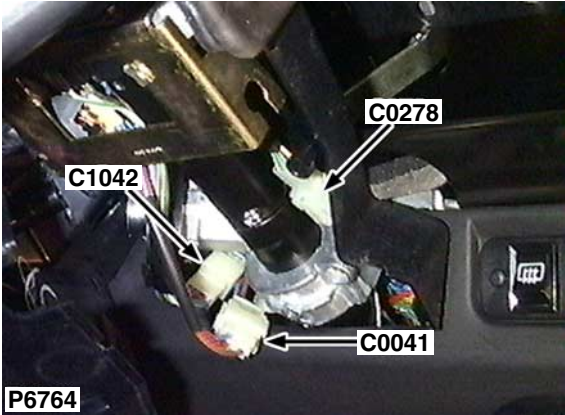

Cav	Col	Cct
1	ULG	3
2	LGB	3
3	WG	3
4	YLG	3
5	RLG	3
6	WG	3

Description: *Switch - Wash / wipe - Windscreen*
 Location: *Behind steering column cowl - RH side*

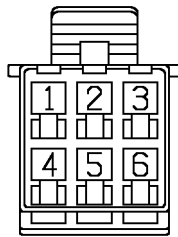

YPC10038

Colour: *NATURAL*
 Gender: *Female*

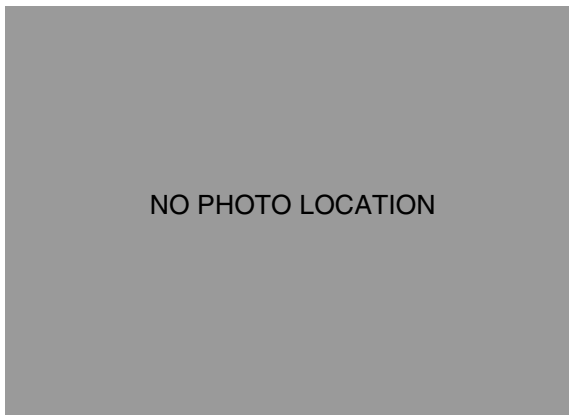

Cav	Col	Cct
1	UG	ALL
2	UB	ALL
3	BS	ALL
4	GW	ALL

Description: *Switch - Trinary*

Location: *Behind RH side of fascia*



Colour: *BLACK*

Gender: *Female*

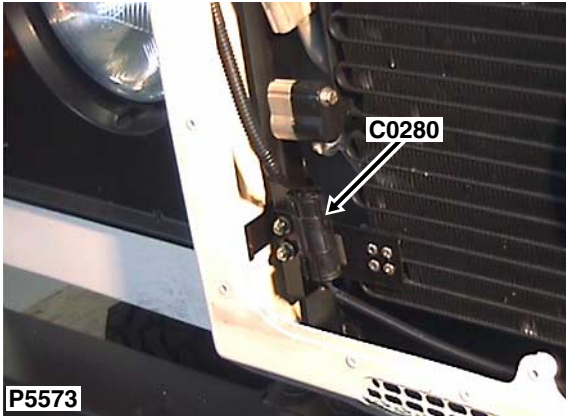

Cav	Col	Cct
1	BN	25
2	B	25

P5573

Description: *Fan - Condenser*
 Location: *In front of radiator*

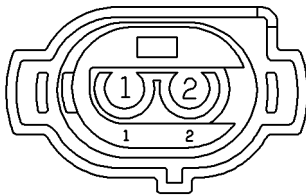

YPC110300

Colour: *BLACK*
 Gender: *Female*

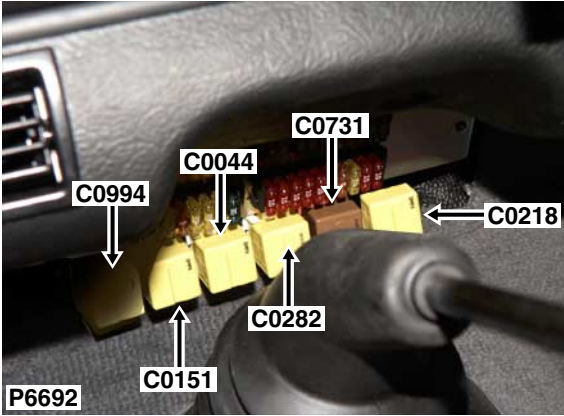

Cav	Col	Cct
30	U	ALL
85	B	ALL
86	WG	ALL
87	U	ALL

Description: *Relay - Headlamp*

Location: *Behind centre of fascia*

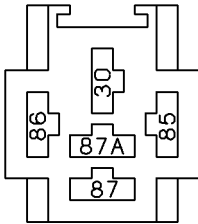

AFU3271

Colour: *YELLOW*

Gender: *Female*

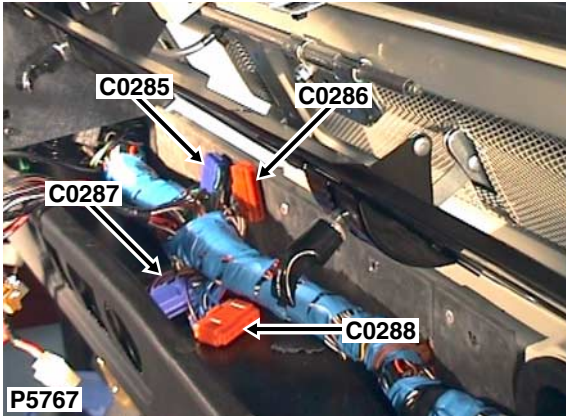

Description: *Header*

Location: *Behind centre of fascia*

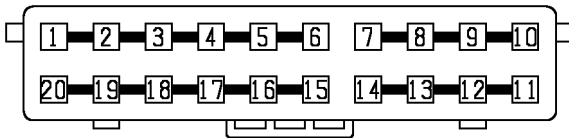

YQC10005

Colour: *BLUE*
 Gender: *Female*

Cav	Col	Cct
1	WG	ALL
2	WG	ALL
3	WG	ALL
4	WG	27
5	WG	26
6	WG	25
7	PB	ALL
8	PB	19
9	PB	ALL
10	PB	ALL
11	WG	2
12	WG	ALL
13	WG	ALL
14	WG	ALL
15	WG	ALL
16	WG	ALL
17	WG	ALL
18	WG	7
19	WG	ALL
20	WG	ALL

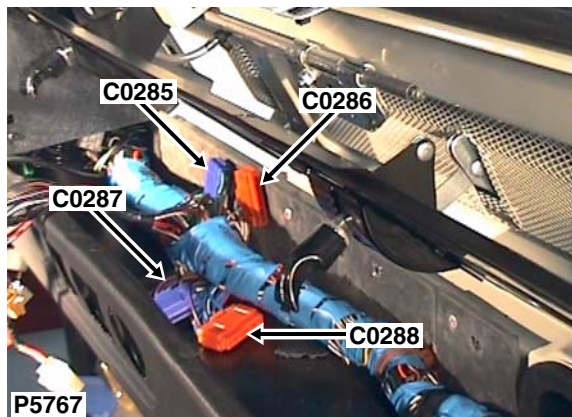

Description: *Header*

Location: *Behind centre of fascia*

Cav	Col	Cct
1	WG	ALL
2	WG	19
3	B	19
5	RB	ALL
6	RB	ALL
7	RB	ALL
8	RB	ALL
10	WB	ALL
11	WB	ALL
12	WB	ALL
17	B	19
18	B	ALL
19	B	ALL
20	B	ALL

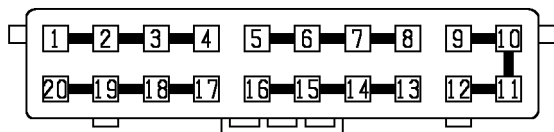

YQC10004

Colour: *YELLOW*

Gender: *Female*

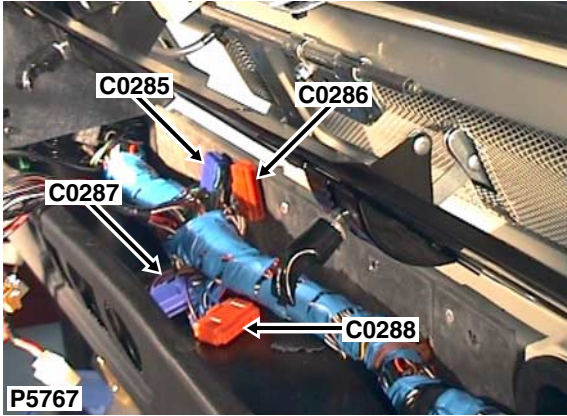

Description: *Header*

Location: *Behind centre of fascia*

Cav	Col	Cct
1	BW	ALL
2	WY	ALL
3	GP	ALL
4	GP	ALL
5	UY	40
6	UY	40
7	K	4
8	BW	ALL
9	BW	4
10	GP	4
12	UY	40
13	K	4
14	K	4

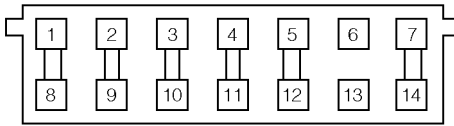

YQC101050

Colour: *BLUE*

Gender: *Female*

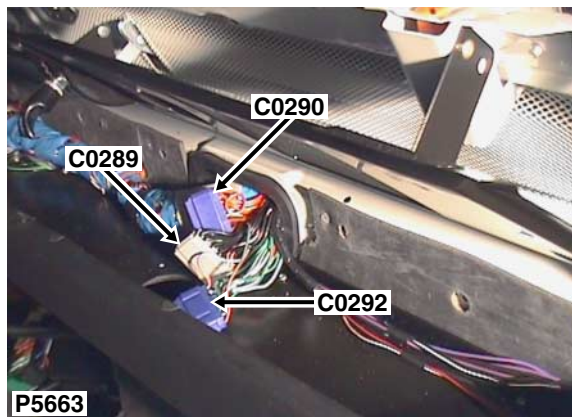

Description: *Header*

Location: *Behind centre of fascia*

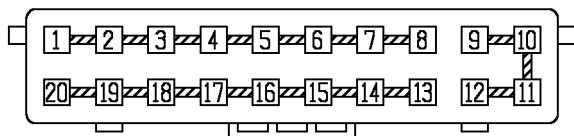

YQC10002

Colour: *GREY*
 Gender: *Female*

Cav	Col	Cct
1	B	26
2	B	3
3	B	22
4	B	6
5	B	40
6	B	3
7	B	3
8	B	26
9	OW	21
10	OW	21
11	B	21
13	B	3
14	B	3
15	B	32
16	B	3
17	B	3
18	B	3
20	B	3

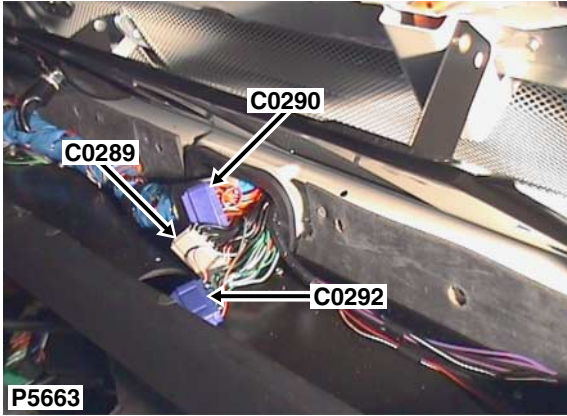

Description: *Header*

Location: *Behind centre of fascia*

Cav	Col	Cct
1	RO	3
2	RO	29
3	RO	29
4	RO	3
5	RO	22
6	RO	40
7	RO	40
8	RO	3
9	B	3
10	B	3
11	B	21
12	B	3
13	RO	3
16	RO	3
17	RO	40
18	RO	40

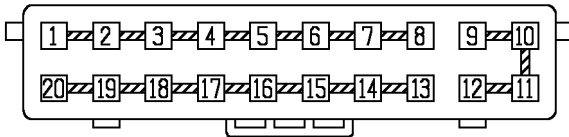

YQC10002

Colour: *GREY*

Gender: *Female*

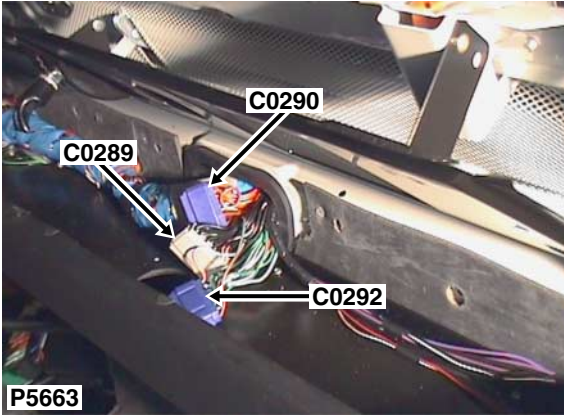

Description: *Header*

Location: *Behind centre of fascia*

Cav	Col	Cct
1	GR	3
2	GR	3
3	GR	3
4	GR	3
5	GR	21
6	GR	3
11	B	3
13	B	3
14	B	3
15	GW	3
16	GW	3
17	GW	3
18	GW	3
19	GW	21
20	GW	3

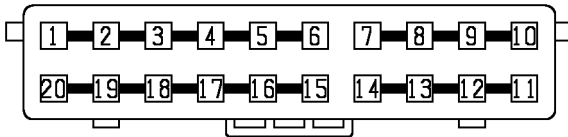

YQC10005

Colour: *BLUE*
 Gender: *Female*

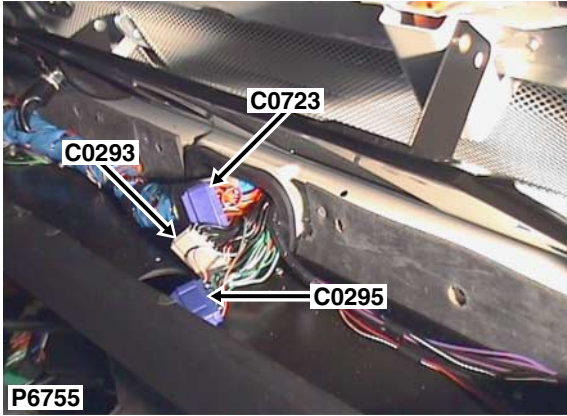

Description: *Header*

Location: *Behind centre of fascia*

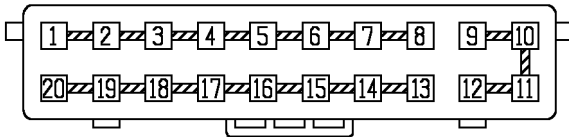

YQC10002

Colour: *GREY*
 Gender: *Female*

Cav	Col	Cct
1	B	2
2	B	2
3	B	43
4	B	5
5	B	40
6	B	2
7	B	2
8	B	26
9	OW	20
10	OW	20
11	B	20
13	B	2
14	B	2
15	B	31
16	B	2
17	B	2
18	B	2
19	B	26
20	B	2

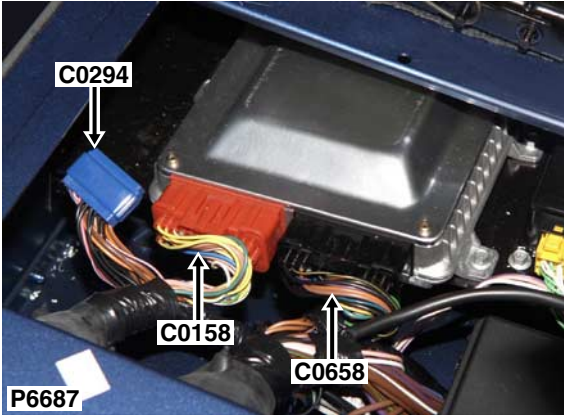

Description: *Header*
 Location: *Beneath RH seat*

Cav	Col	Cct
1	B	ALL
2	B	ALL
3	B	ALL
4	B	ALL
5	B	25
6	B	25
7	KP	ALL
8	KP	ALL
9	KP	4
15	NO	ALL
16	NO	46
17	NO	ALL
18	NO	ALL
19	NO	25
20	NO	25

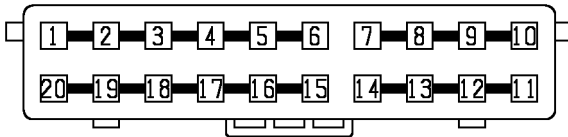

YQC10005

Colour: *BLUE*
 Gender: *Female*

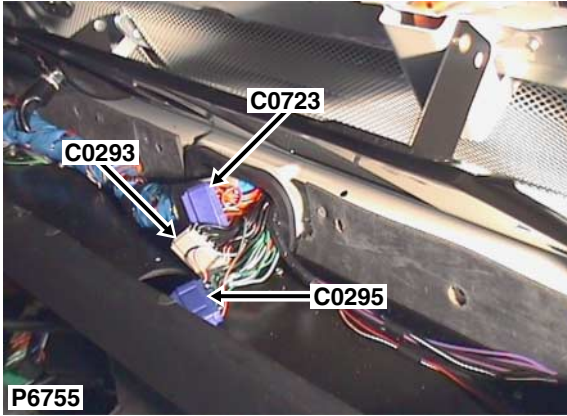

Description: *Header*

Location: *Behind centre of fascia*

Cav	Col	Cct
1	GR	2
2	GR	2
3	GR	2
4	GR	2
5	GR	20
6	GR	2
11	B	2
12	B	2
13	B	2
14	B	2
15	GW	2
16	GW	2
17	GW	2
18	GW	2
19	GW	20
20	GW	2

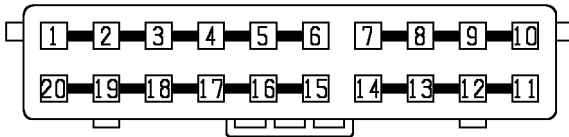

YQC10005

Colour: *BLUE*

Gender: *Female*

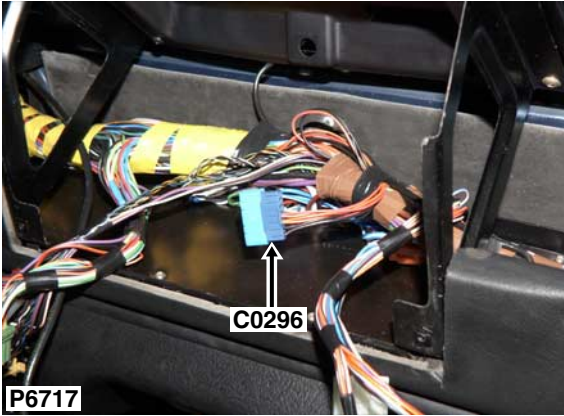

Cav	Col	Cct
1	B	26
2	B	26
3	RO	ALL
4	RO	26
7	PN	ALL
8	B	26
9	B	26
10	RO	ALL
11	RO	ALL
13	PN	19
14	PN	21

Description: *Header*

Location: *Behind centre of fascia*

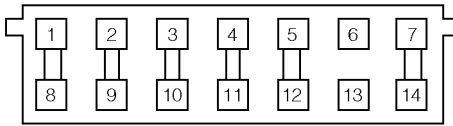

YQC101050

Colour: *BLUE*

Gender: *Female*

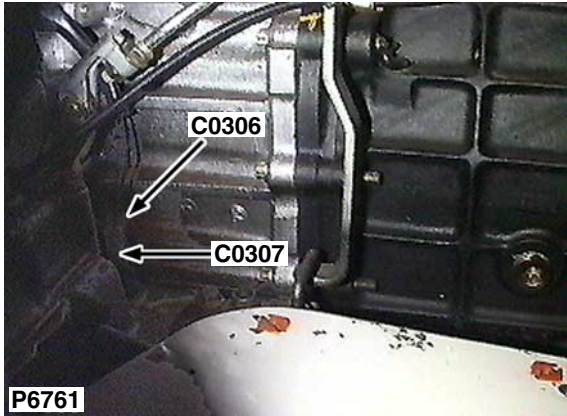

Cav	Col	Cct
1	BU	ALL

P6761

Description: *Differential lock unit*

Location: *LH side of gearbox*

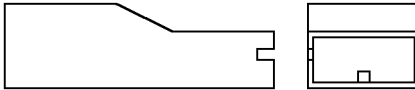

AAU1010

Colour: *BLACK*

Gender: *Female*

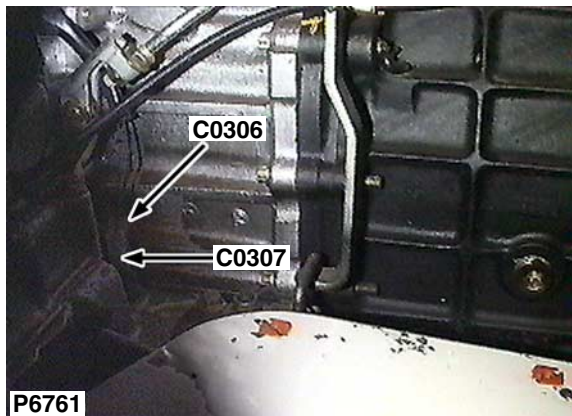

P6761

Description: *Differential lock unit*

Location: *LH side of gearbox*

Cav	Col	Cct
1	B	ALL

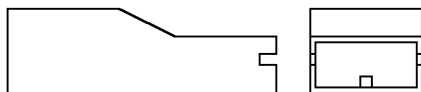

AAU1010

Colour: *BLACK*

Gender: *Female*

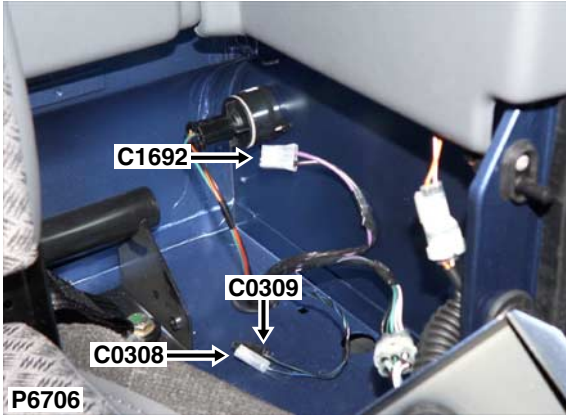

Cav	Col	Cct
1	BU	41

Description: *Speaker - Rear - RH*

Location: *Behind RH rear trim panel*

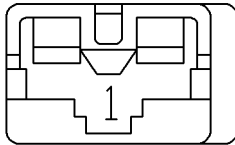

AFU4521

Colour: *NATURAL*

Gender: *Female*

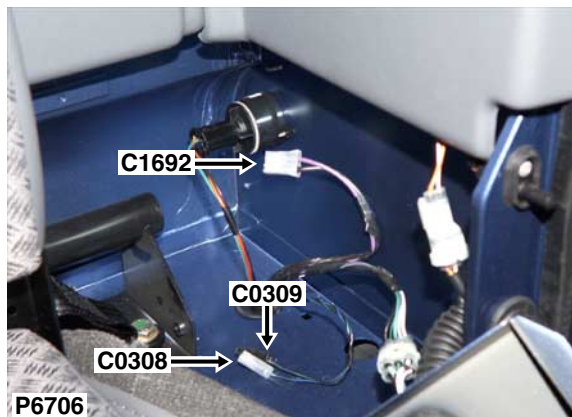

Cav	Col	Cct
1	BG	41

Description: *Speaker - Rear - RH*

Location: *Behind RH rear trim panel*

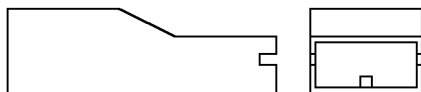

AAU1010

Colour: *BLACK*

Gender: *Female*

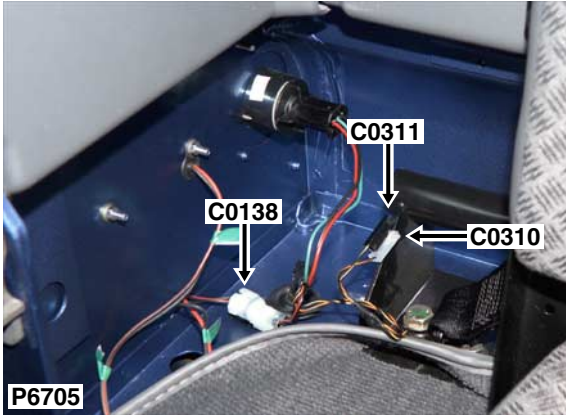

Cav	Col	Cct
1	BO	41

Description: *Speaker - Rear - LH*

Location: *Behind LH rear trim panel*

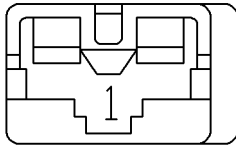

AFU4521

Colour: *NATURAL*

Gender: *Female*

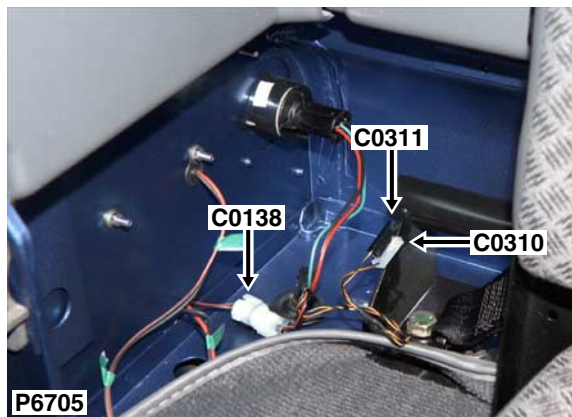

Cav	Col	Cct
1	BY	41

Description: *Speaker - Rear - LH*

Location: *Behind LH rear trim panel*

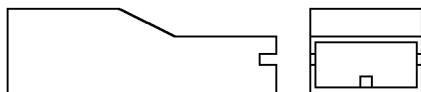

AAU1010

Colour: *BLACK*

Gender: *Female*

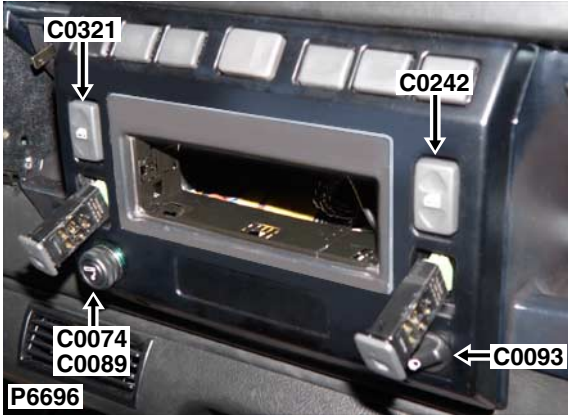

Cav	Col	Cct
1	B	27
2	RG	27
3	U	ALL
4	R	ALL
6	RO	ALL

Description: *Switch - Window - Front - LH*
 Location: *Behind centre of fascia*

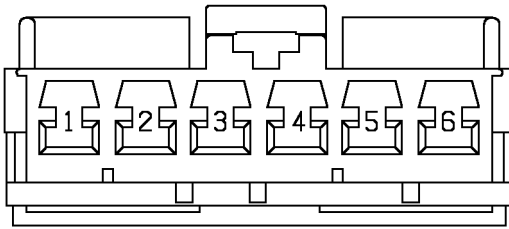

YPC113220

Colour: *WHITE*
 Gender: *Female*

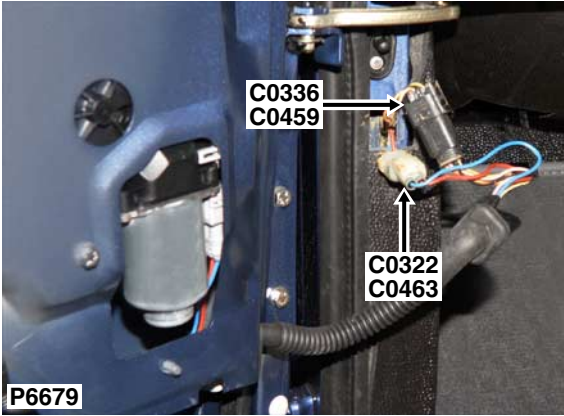

Cav	Col	Cct
1	R	27
2	U	27

Description: *Passenger door harness to main harness*
Location: *Base of RH 'A' post*

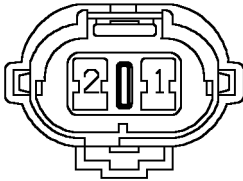

AFU3584

Colour: *NATURAL*
Gender: *Male*

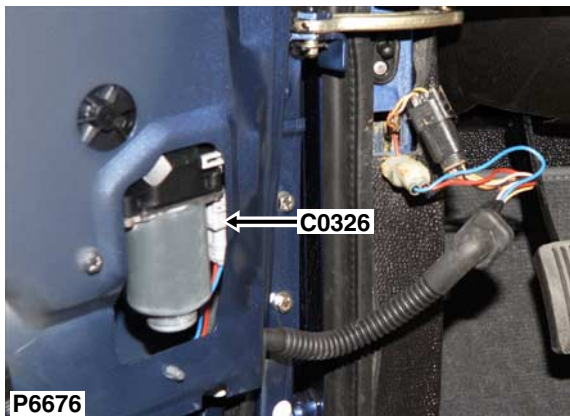

Cav	Col	Cct
1	R	27
2	U	27

Description: *Motor - Window - Front*

Location: *Behind front door trim panel*

NO CONNECTOR FACE

Colour: *BLACK*

Gender: *Female*

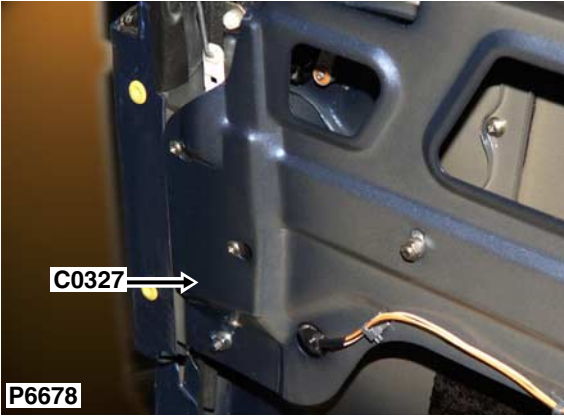

Cav	Col	Cct
1	O	39
2	K	39

Description: *Motor - Central door locking - Passenger*

Location: *Behind front door trim panel*

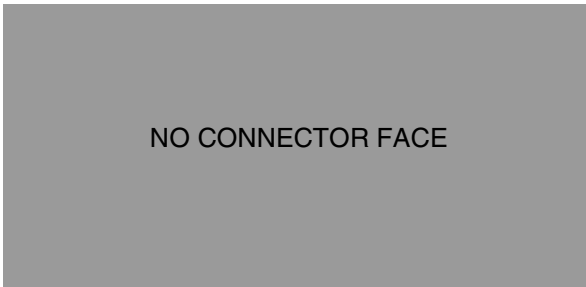

Colour: *BLACK*

Gender: *Female*

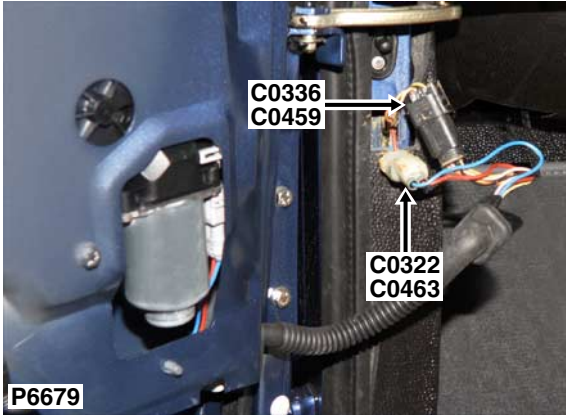

Cav	Col	Cct
1	O	38
2	K	38
3	B	38
4	YK	38

Description: *Drivers door harness to main harness - LHD*
 Location: *Base of LH 'A' post*

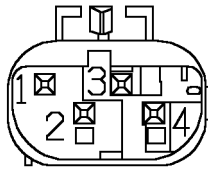

YPC110750

Colour: *BLACK*
 Gender: *Male*

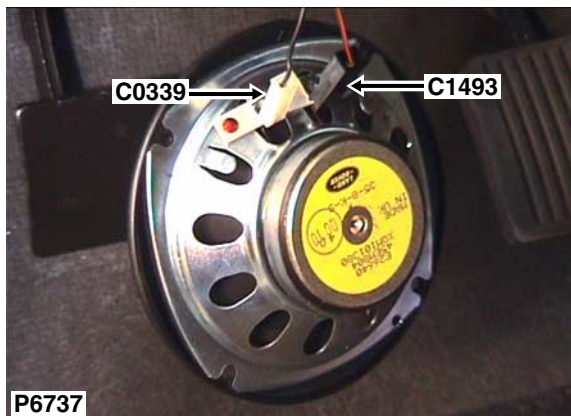

Cav	Col	Cct
1	BK	2

Description: *Speakers - Front*

Location: *Under RH side of fascia*

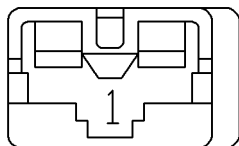

AFU4521

Colour: *NATURAL*

Gender: *Female*

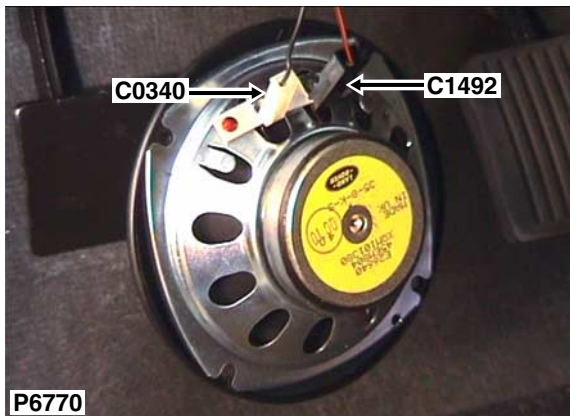

Cav	Col	Cct
1	BW	ALL

P6770

Description: *Speakers - Front*

Location: *Under LH side of fascia*

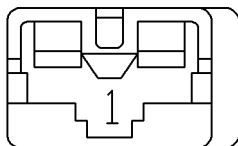

AFU4521

Colour: *NATURAL*

Gender: *Female*

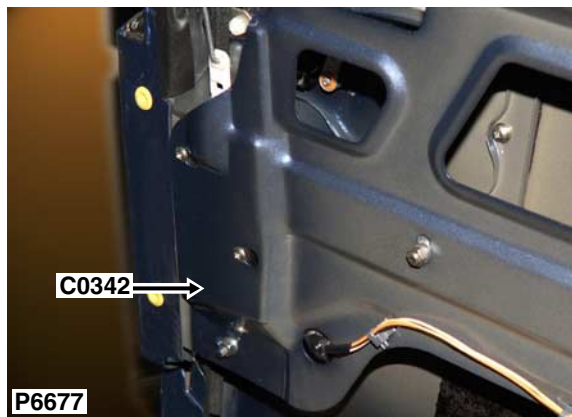

Cav	Col	Cct
1	O	38
2	K	38
3	YK	38
4	B	38

Description: *Motor - Central door locking - Driver*

Location: *Behind front door trim panel*

NO CONNECTOR FACE

Colour: *BLACK*

Gender: *Female*

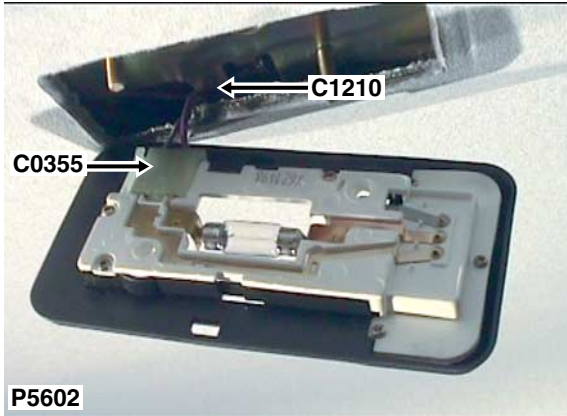

Cav	Col	Cct
1	PW	ALL
3	PN	ALL

P5602

Description: *Lamp - Interior - Front*

Location: *Front of headlining in the centre*



YPC10026

Colour: *NATURAL*

Gender: *Female*

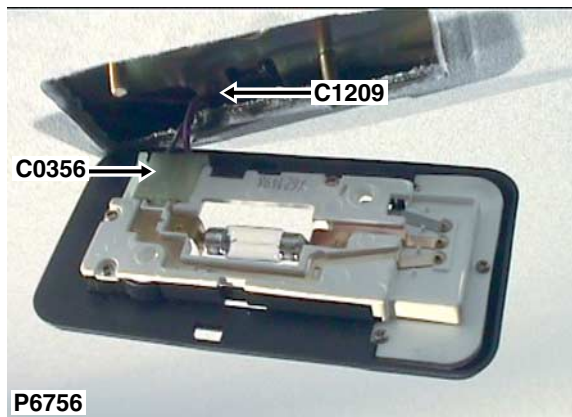

Cav	Col	Cct
1	PW	44
3	PN	44

Description: *Lamp - Interior - Rear*

Location: *Rear of headlining*

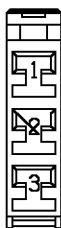

YPC10026

Colour: *NATURAL*

Gender: *Female*

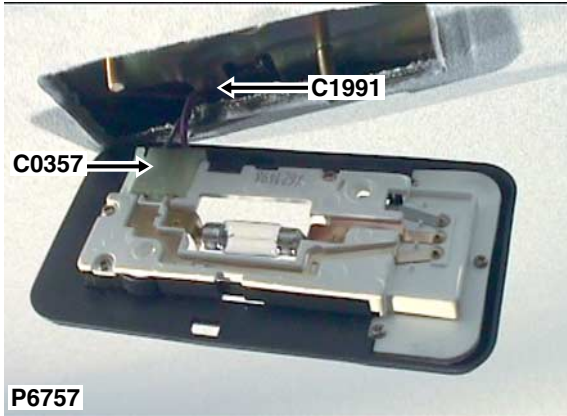

Cav	Col	Cct
1	PW	24
3	PN	24

Description: *Lamp - Interior - Rear*
 Location: *Rear of headlining*



YPC10026

Colour: *NATURAL*
 Gender: *Female*

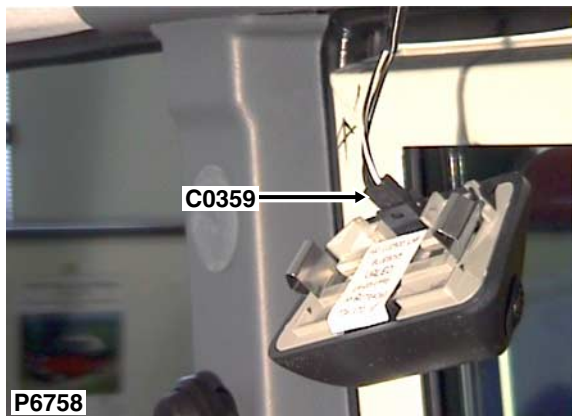

Cav	Col	Cct
1	BN	34
2	B	34
3	WB	34

Description: *Sensor - Volumetric*

Location: *Behind headlining top of RH 'B' post*

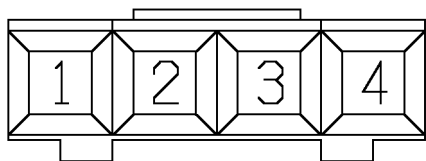

YPC10199

Colour: *BLACK*

Gender: *Female*

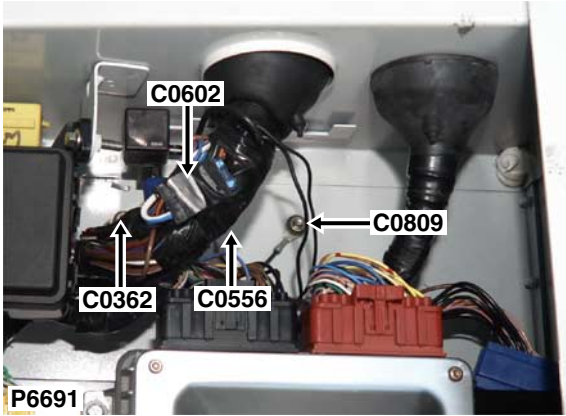

Cav	Col	Cct
1	B	4

Description: *Earth - ABS*
Location: *Beneath RH seat*

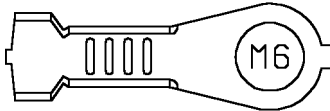

YPG10014

Colour: *TIN-PLATE*
Gender: *Female*

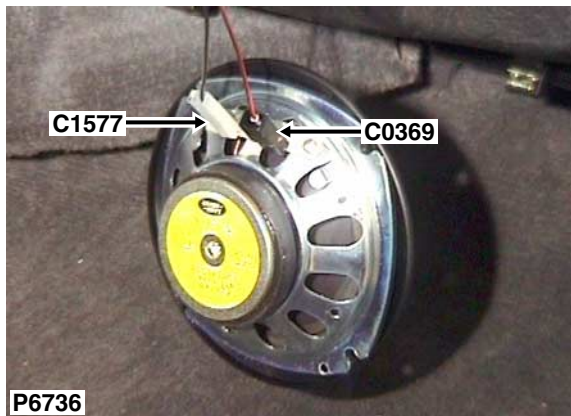

Cav	Col	Cct
1	BR	3

Description: *Speakers - Front*

Location: *Under RH side of fascia*

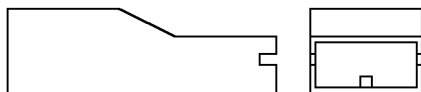

AAU1010

Colour: *BLACK*

Gender: *Female*

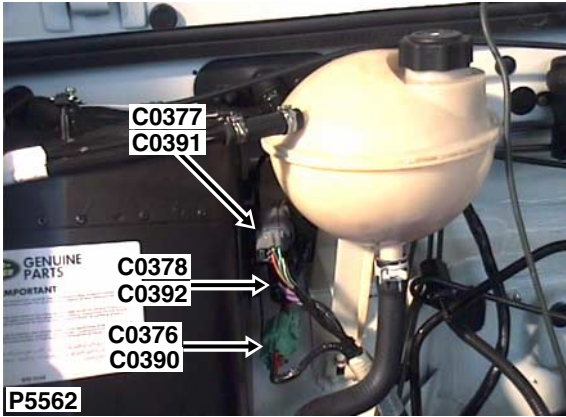

Cav	Col	Cct
1	RO	ALL
2	RB	ALL
3	RY	ALL
4	GR	ALL
5	GW	ALL
6	GP	ALL
7	GN	2
7	RY	3
8	RY	2
8	GN	3
9	GN	ALL

Description: *Main harness to chassis harness*

Location: *Rear of engine compartment*

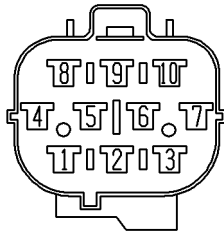

YPC10633

Colour: *ORANGE*

Gender: *Female*

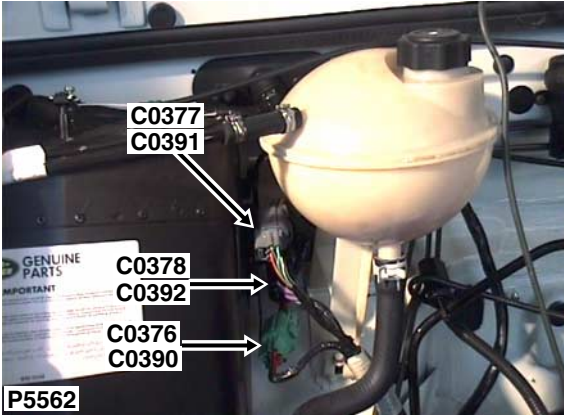

Description: *Main harness to chassis harness*

Location: *Rear of engine compartment*

Cav	Col	Cct
1	SB	ALL
2	WB	ALL
3	WG	ALL
4	BG	ALL
5	GB	ALL
6	OG	ALL



YPC10542

Colour: *ORANGE*

Gender: *Female*

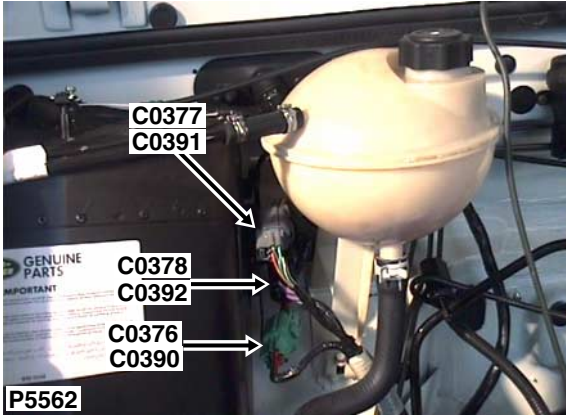

Cav	Col	Cct
1	P	ALL
4	WP	4

Description: *Main harness to chassis harness*
Location: *Rear of engine compartment*

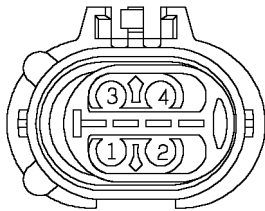

Colour: *ORANGE*
Gender: *Male*

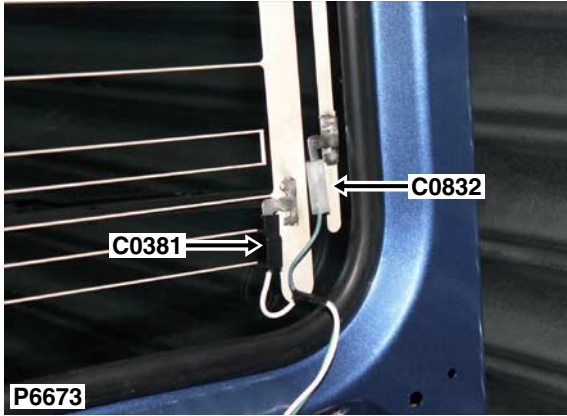

Cav	Col	Cct
1	WB	1

Description: *Heater element - Rear screen*

Location: *LH side of taildoor*

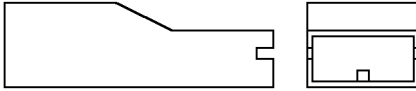

AAU1010

Colour: *BLACK*

Gender: *Female*

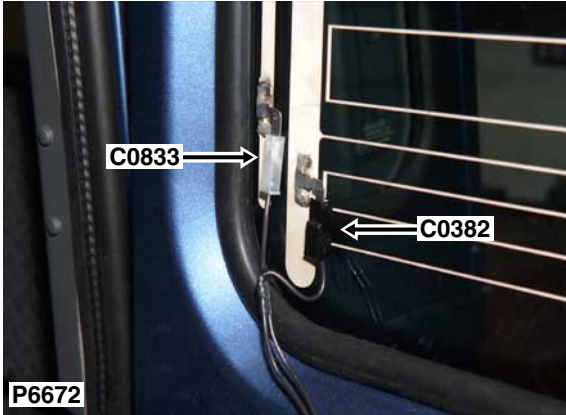

Cav	Col	Cct
1	B	1

Description: *Heater element - Rear screen*
 Location: *RH side of tail door*

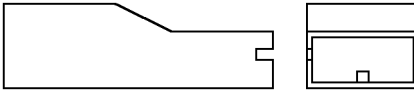

AAU1010

Colour: *BLACK*
 Gender: *Female*

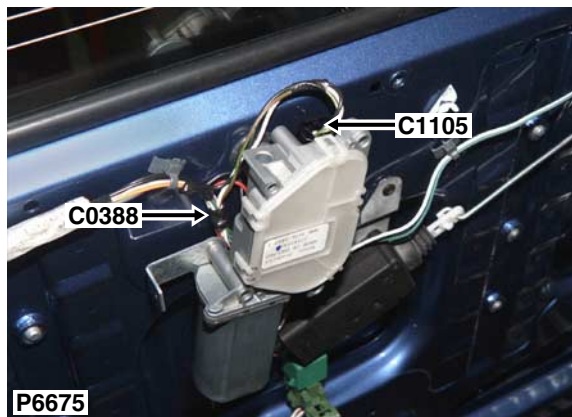

Description: *Motor - Wiper - Rear screen*

Location: *Centre of taildoor, behind trim panel*

Cav	Col	Cct
1	B	1
2	RLG	1

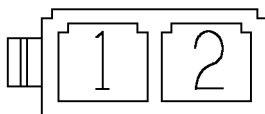

YPC106820

Colour: *BLACK*

Gender: *Female*

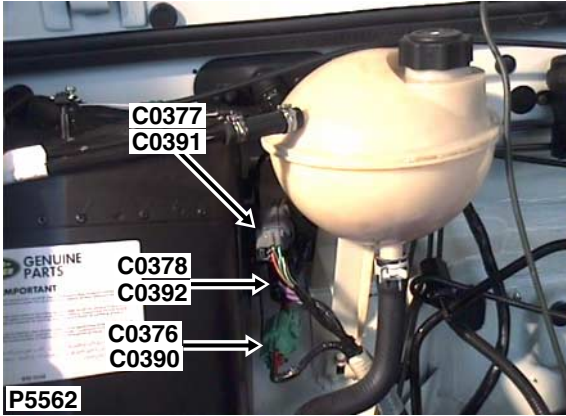

Cav	Col	Cct
1	RO	10
2	RB	10
3	RY	10
4	GR	10
5	GW	10
6	GP	10
7	S	10
8	W	10
9	GN	10

Description: *Chassis harness to main harness*

Location: *Rear of engine compartment*

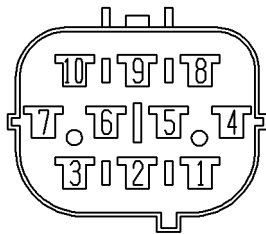

YPC10468

Colour: *ORANGE*

Gender: *Male*

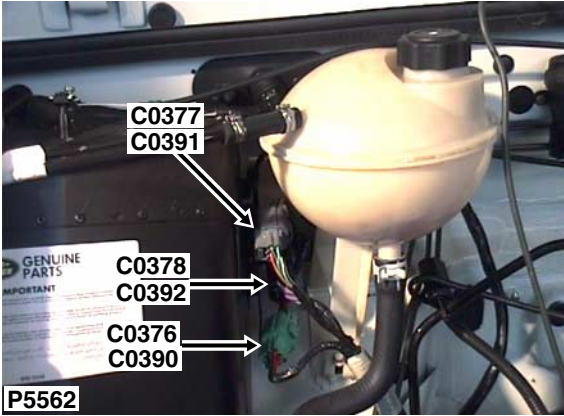

Description: *Chassis harness to main harness*

Location: *Rear of engine compartment*

Cav	Col	Cct
1	SB	ALL
2	WB	10
3	WG	ALL
4	BG	10
5	GB	ALL
6	OG	11

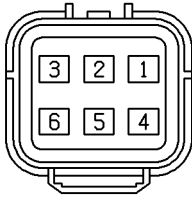

YPC106620

Colour: *ORANGE*

Gender: *Male*

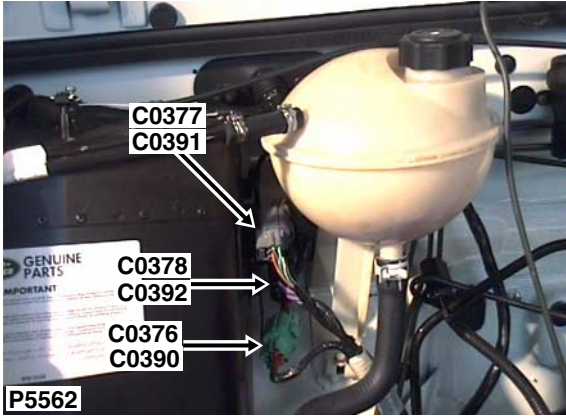

Cav	Col	Cct
1	P	10
4	WP	11

Description: *Chassis harness to main harness*

Location: *Rear of engine compartment*

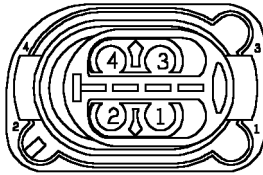

YPC110200

Colour: *ORANGE*

Gender: *Female*

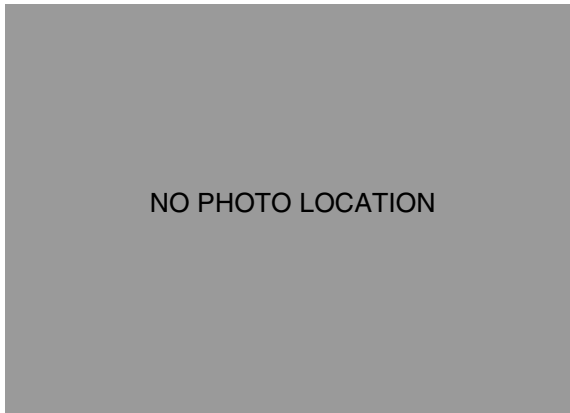

Cav	Col	Cct
1	NY	ALL
2	U	ALL
4	G	ALL

Description: *Resistor - Blower motor*

Location: *Behind RH side of fascia*

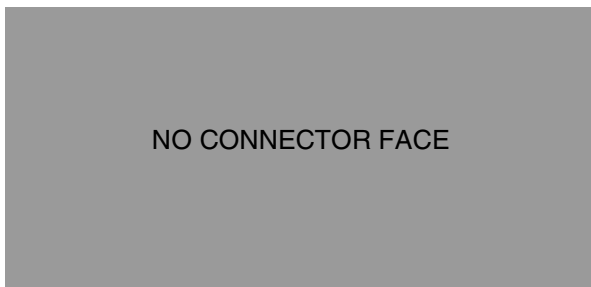

Colour: *WHITE*

Gender: *Female*

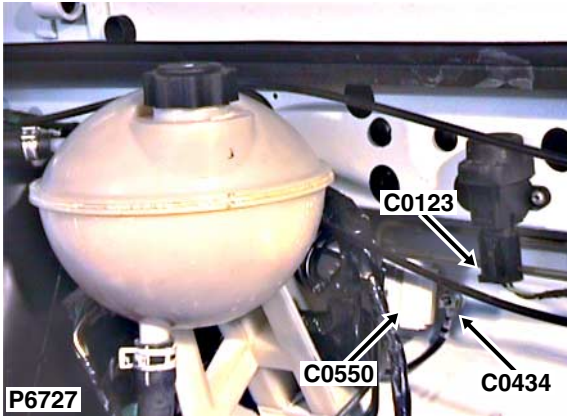

Cav	Col	Cct
1	B	ALL

Description: *Earth - ABS modulator*
 Location: *Top of bulkhead - centre*

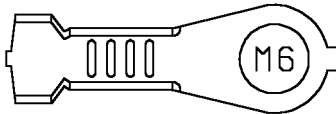

YPG10013

Colour: *TIN-PLATE*
 Gender: *Female*

C0438

CONNECTOR DETAILS

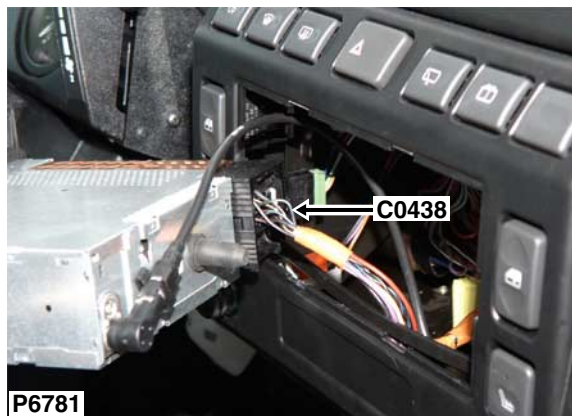

Description: *Radio / cassette player*

Location: *Behind radio*

Cav	Col	Cct
1	BW	ALL
2	BK	ALL
3	BY	41
5	WO	ALL
6	BG	41
8	BN	ALL
9	PN	ALL
11	BR	ALL
12	BO	41
13	RO	ALL
14	BU	41
15	B	ALL

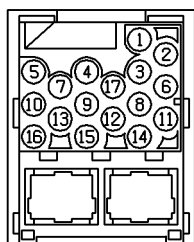

YPC115120

Colour: *BLACK*

Gender: *Female*

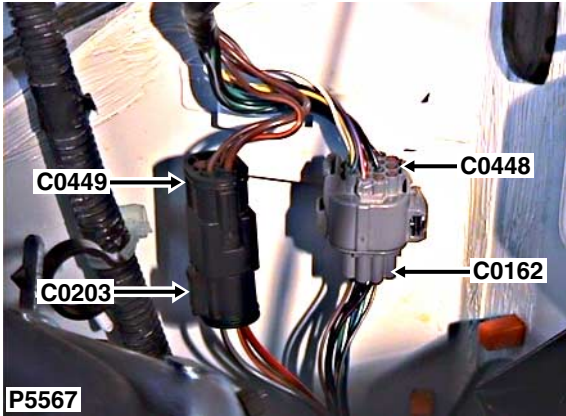

Description: *Main harness to engine harness*

Location: *Lower RH rear of engine compartment*

Cav	Col	Cct
1	WN	ALL
2	NY	ALL
3	BU	ALL
4	GN	ALL
5	LGP	ALL
6	B	ALL
7	SR	ALL
8	BS	ALL
9	BP	ALL
10	BR	ALL
11	BY	ALL
12	WG	4
12	LGS	ALL
13	WG	7
14	GU	ALL

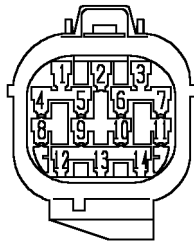

YPC10549

Colour: *GREY*

Gender: *Female*

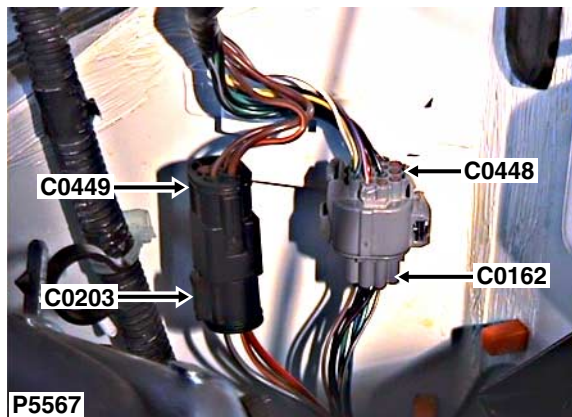

Cav	Col	Cct
1	NR	ALL
2	N	4
2	WG	7
3	NS	25

Description: *Main harness to engine harness*

Location: *Lower RH rear of engine compartment*

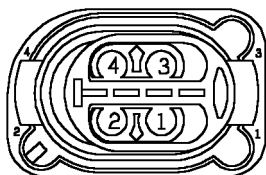

YPC110200

Colour: *BLACK*

Gender: *Female*

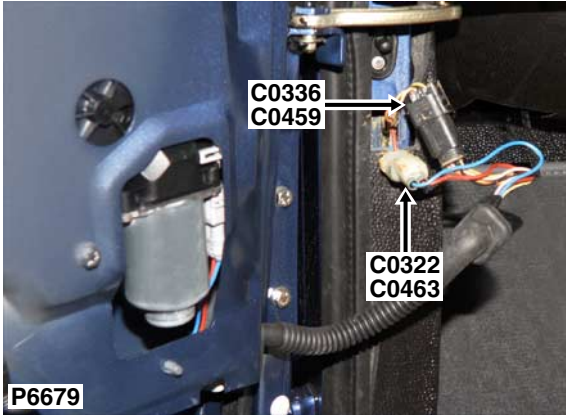

Cav	Col	Cct
1	O	20
2	K	20
3	B	20
4	YK	20

Description: *Main harness to door harness*
 Location: *Base of driver side 'A' post*

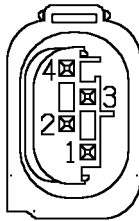

YPC117050

Colour: *BLACK*
 Gender: *Female*

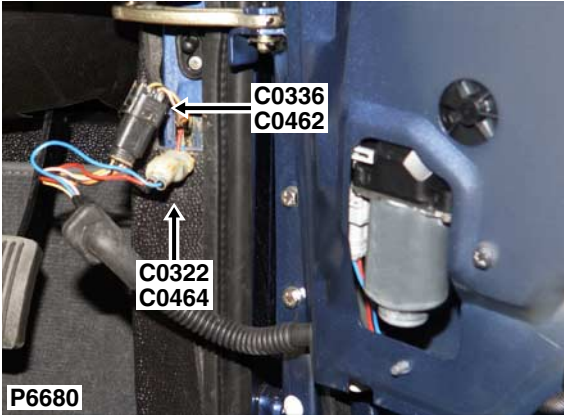

Cav	Col	Cct
1	O	20
2	K	20

Description: *Main harness to door harness*

Location: *Base of driver side 'A' post*

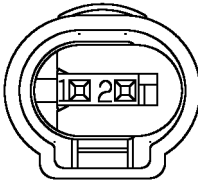

YPC116820

Colour: *BLACK*

Gender: *Female*

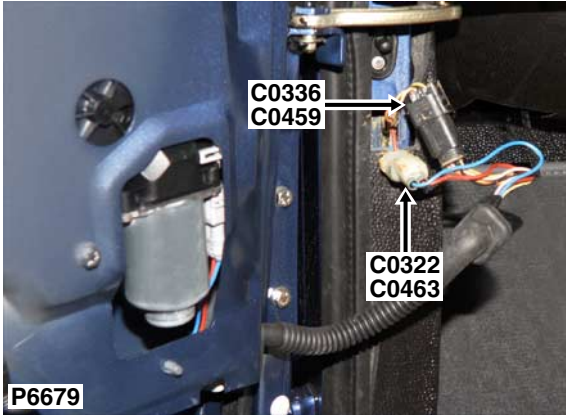

Cav	Col	Cct
1	R	ALL
2	U	ALL

Description: *Main harness to door harness*
Location: *Base of passenger side 'A' post*

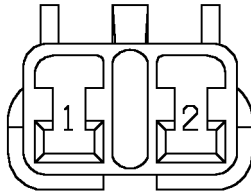

AFU3635

Colour: *NATURAL*
Gender: *Female*

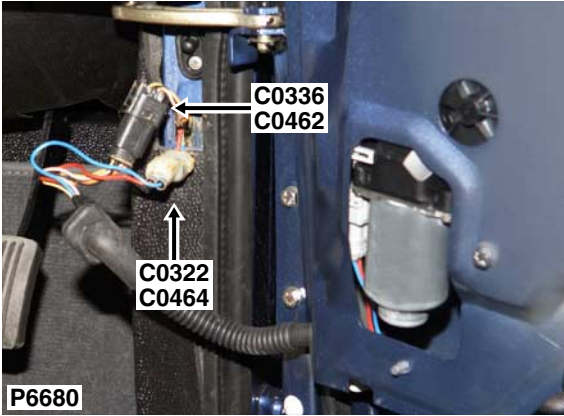

Cav	Col	Cct
1	OR	ALL
2	OU	ALL

Description: *Main harness to door harness*

Location: *Base of driver side 'A' post*

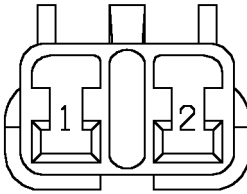

AFU3635

Colour: *NATURAL*

Gender: *Female*

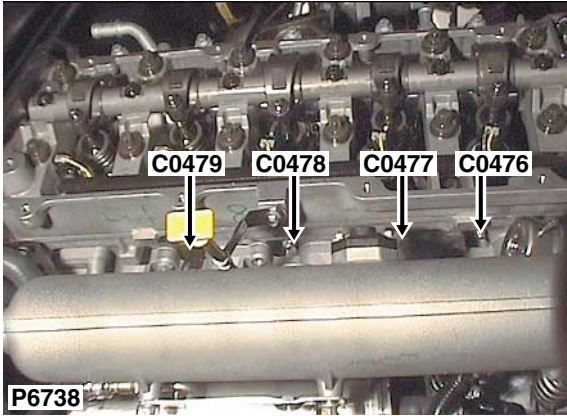

Cav	Col	Cct
1	B	ALL
1	YB	ALL

Description: *Glow plug - Td5*
Location: *Top of engine - RH side*

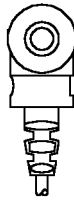

YPC107890

Colour: *BLACK*
Gender: *Female*

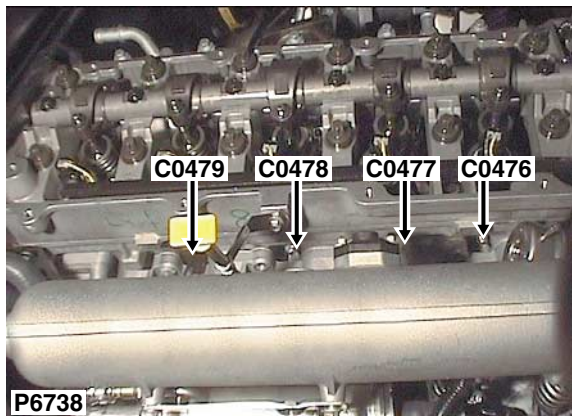

Cav	Col	Cct
1	B	ALL

Description: *Glow plug - Td5*

Location: *Top of engine - RH side*

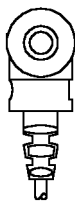

YPC107890

Colour: *BLACK*

Gender: *Female*

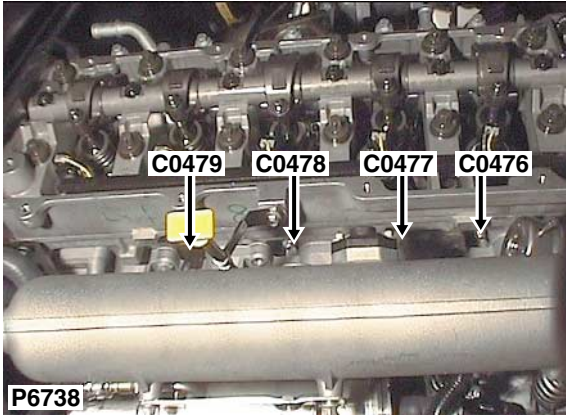

Cav	Col	Cct
1	B	ALL

Description: *Glow plug - Td5*
Location: *Top of engine - RH side*

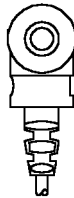

YPC107890

Colour: *BLACK*
Gender: *Female*

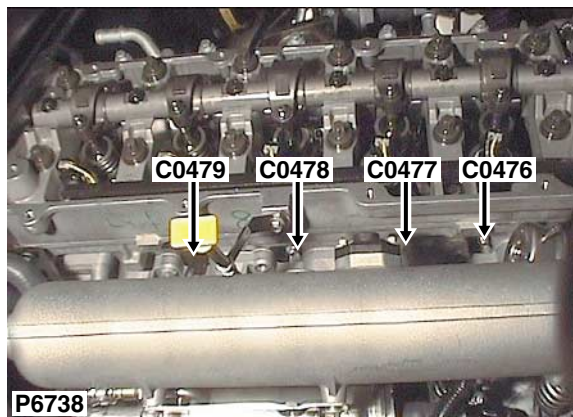

Cav	Col	Cct
1	B	ALL

Description: *Glow plug - Td5*

Location: *Top of engine - RH side*

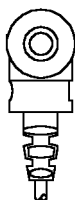

YPC107890

Colour: *BLACK*

Gender: *Female*

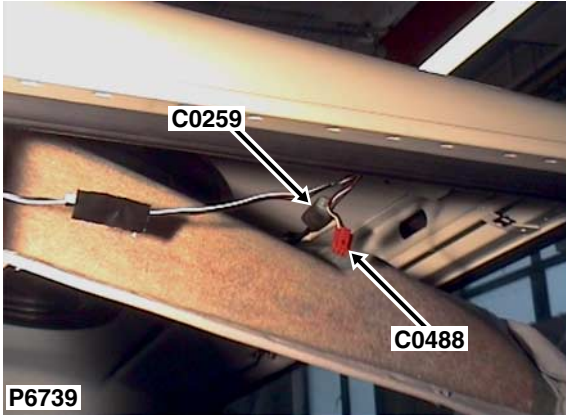

Cav	Col	Cct
1	B	ALL
2	PW	ALL
3	PN	ALL
4	PU	ALL
4	PN	30
5	K	ALL
6	O	ALL
8	BN	ALL
9	B	19
10	WB	ALL

Description: *Main harness to interior lamp harness*
 Location: *Headlining - front RH side*

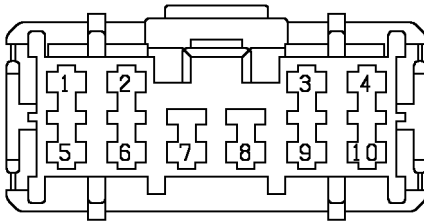

YPC10534

Colour: *LIGHT GREY*
 Gender: *Female*

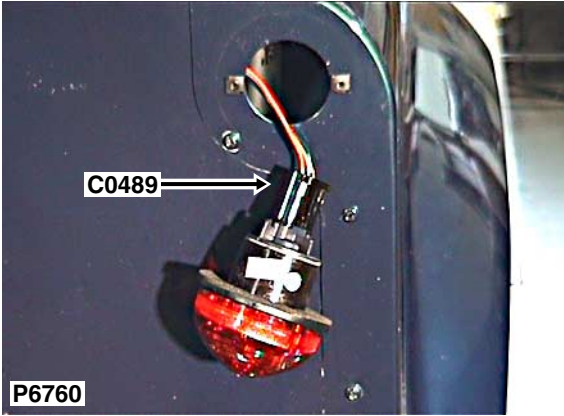

Cav	Col	Cct
1	B	ALL
2	GP	16
3	RO	16

Description: *Lamp - Tail - RH*

Location: *RH rear of vehicle*

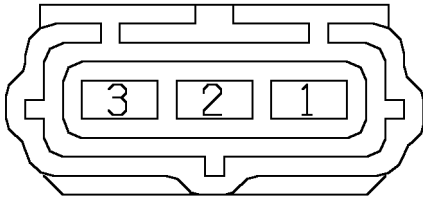

YPC10068

Colour: *BLACK*

Gender: *Female*

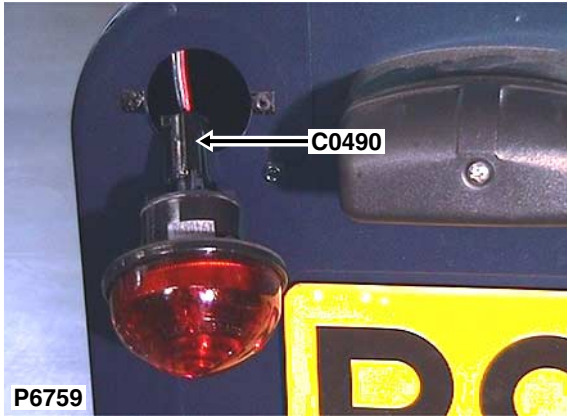

Cav	Col	Cct
1	B	16
2	GP	16
3	RB	16

Description: *Lamp - Tail - LH*
 Location: *LH rear of vehicle*

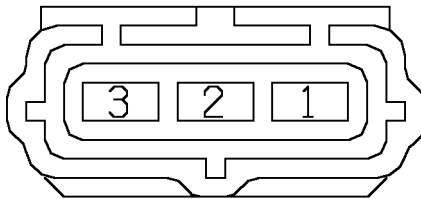

YPC10068

Colour: *BLACK*
 Gender: *Female*

C0499

CONNECTOR DETAILS



Cav	Col	Cct
1	GR	ALL
2	RY	ALL
3	B	ALL
4	GW	ALL
5	RO	ALL
6	GP	ALL
7	RB	ALL

Description: *Trailer pick-up*

Location: *Behind centre of rear bumper*

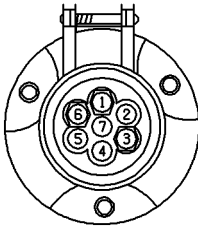

PC113030

Colour: *BLACK*

Gender: *Female*

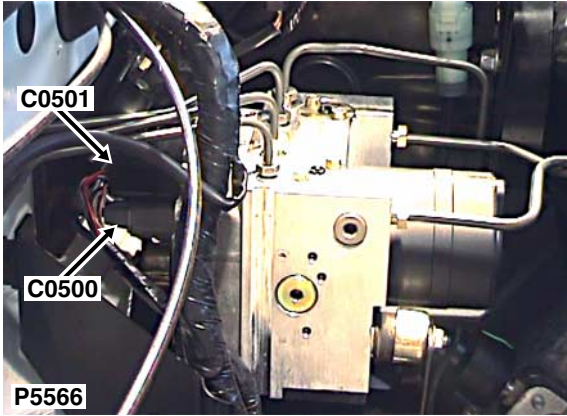

Cav	Col	Cct
1	B	6

Description: *Modulator - ABS*

Location: *Behind ABS modulator*

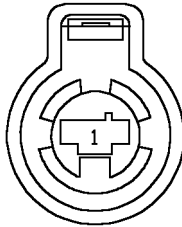

YPC109840

Colour: *LIGHT GREY*

Gender: *Female*

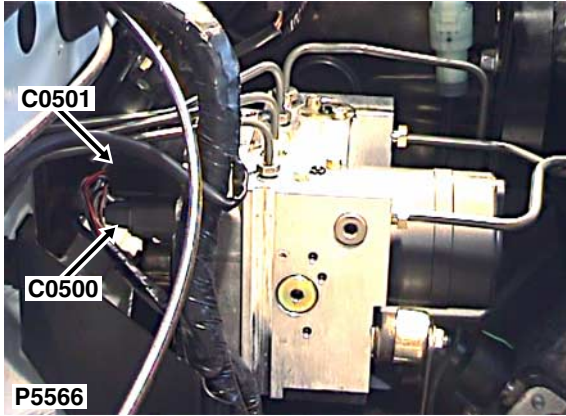

Cav	Col	Cct
1	SW	6
2	SR	6
4	SK	6
5	SP	6
8	B	6
9	RB	6
10	SG	6
11	SU	6
12	SN	6
13	SY	6

Description: *Modulator - ABS*

Location: *Behind ABS modulator*

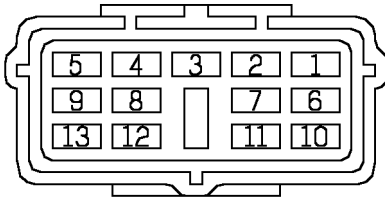

YPC10062

Colour: *BLACK*

Gender: *Female*



Cav	Col	Cct
1	W	4
2	W	4

Description: *Sensor - ABS - Rear - LH*
Location: *Beneath centre of vehicle*

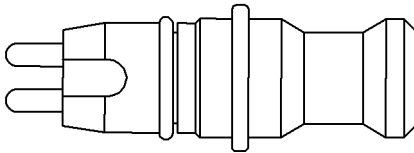

51277057

Colour: *NATURAL*
Gender: *Male*

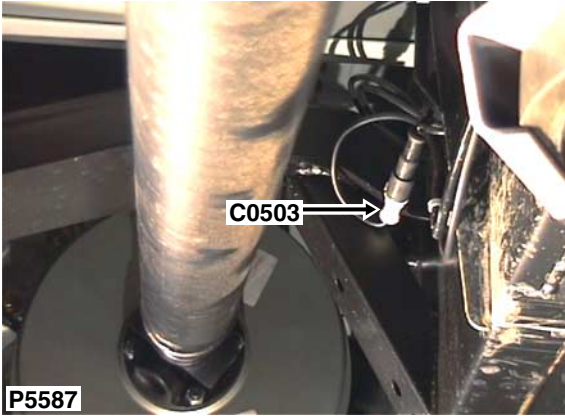

Cav	Col	Cct
1	G	4
2	G	4

Description: *Sensor - ABS - Rear - RH*
Location: *Beneath centre of vehicle*

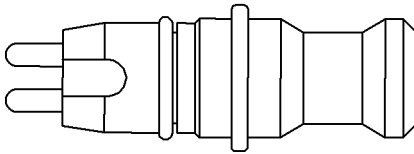

51277057

Colour: *NATURAL*
Gender: *Male*

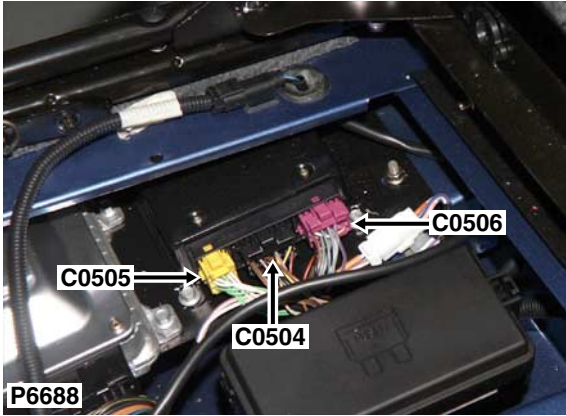

Cav	Col	Cct
1	NW	4
2	GO	4
5	K	4
8	NR	ALL
9	BW	4
10	SP	4
11	YK	4
12	B	4
17	YS	ALL
18	RS	ALL

Description: ECU - ABS

Location: Beneath RH seat

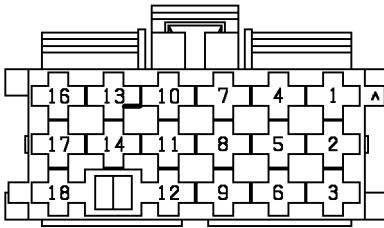

YPC108720

Colour: BLACK

Gender: Female

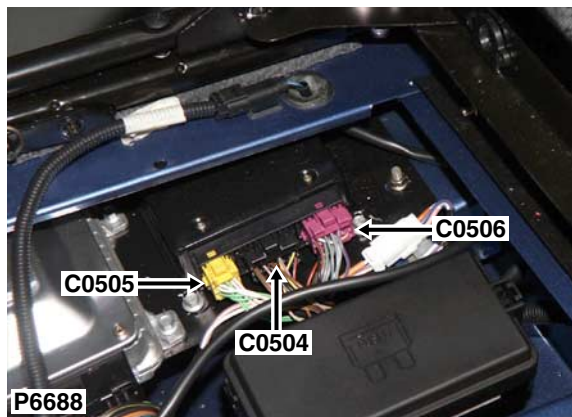

Description: *ECU - ABS*
 Location: *Beneath RH seat*

Cav	Col	Cct
1	W	4
2	W	4
3	G	4
4	G	4
5	G	4
6	G	4
7	W	4
8	W	4

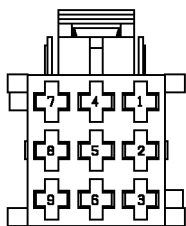

YPC108770

Colour: *YELLOW*
 Gender: *Female*

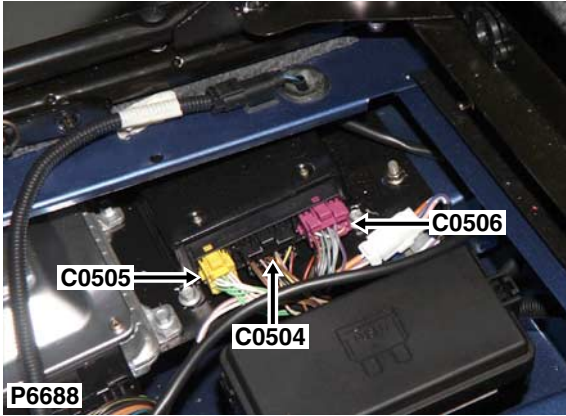

Description: *ECU - ABS*

Location: *Beneath RH seat*

Cav	Col	Cct
1	SW	ALL
2	SR	ALL
3	B	ALL
4	SG	ALL
5	SU	ALL
6	RB	ALL
7	SY	ALL
8	SN	ALL
10	SP	ALL
11	SK	ALL
15	WO	4

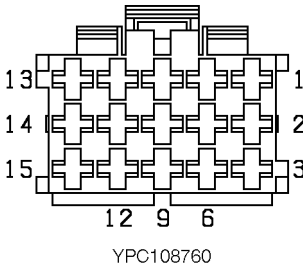

Colour: *PURPLE*

Gender: *Female*

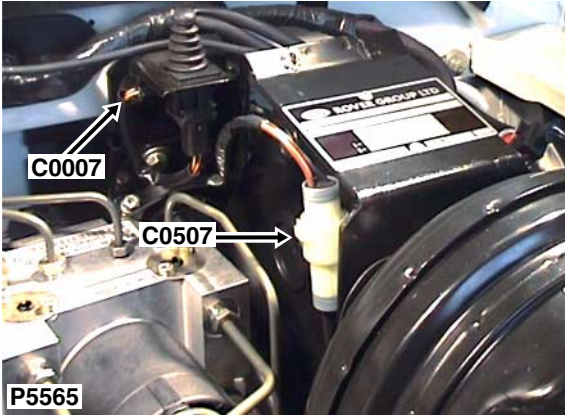

Cav	Col	Cct
1	NR	6
2	B	6

Description: *Pump - Return - ABS*

Location: *Adjacent pedal box*

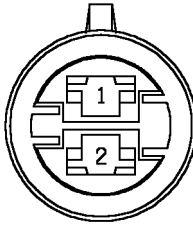

AFU3727

Colour: *NATURAL*

Gender: *Female*

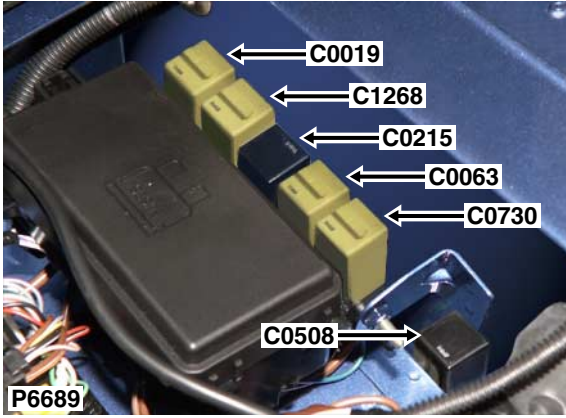

Cav	Col	Cct
1	NR	ALL
2	WO	4
3	NW	4
4	B	ALL

Description: *Relay - ABS - Return pump*
 Location: *Beneath RH seat*

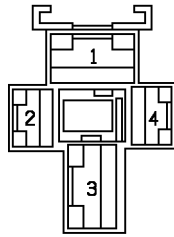

YPP10005

Colour: *BLACK*
 Gender: *Female*

C0516

CONNECTOR DETAILS



Cav	Col	Cct
1	W	4
2	W	4

P5574

Description: *Sensor - ABS - Front - LH*

Location: *LH side of engine compartment*

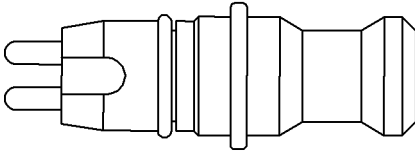

51277057

Colour: *NATURAL*

Gender: *Male*

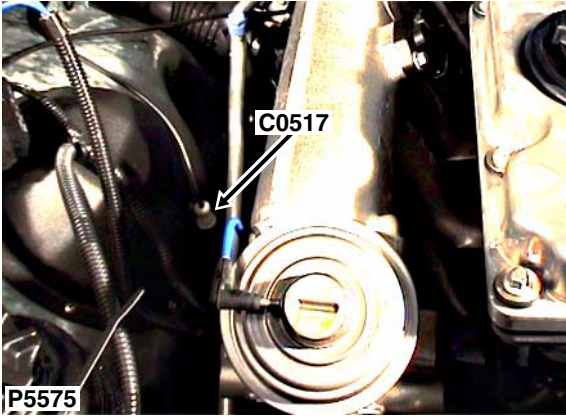

Cav	Col	Cct
1	G	4
2	G	4

Description: *Sensor - ABS - Front - RH*

Location: *RH side of engine compartment*

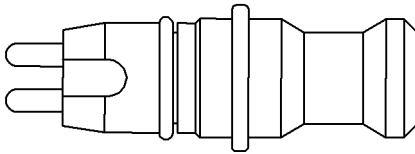

51277057

Colour: *NATURAL*

Gender: *Male*

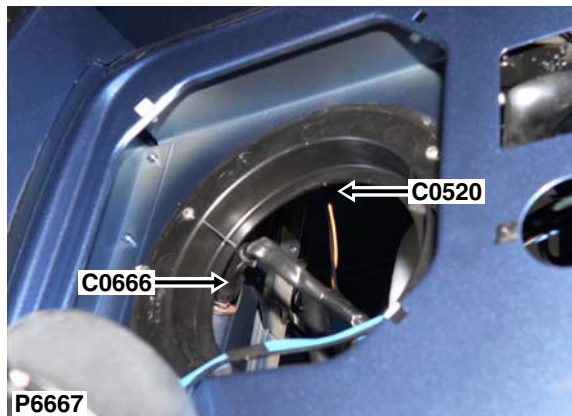

Cav	Col	Cct
1	B	37
2	OB	37

Description: *Unit - Sounder - Alarm*

Location: *Behind LH headlamp*

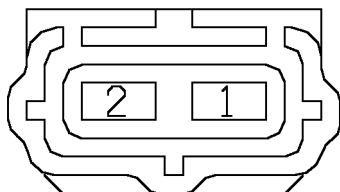

YPC10070

Colour: *BLACK*

Gender: *Female*

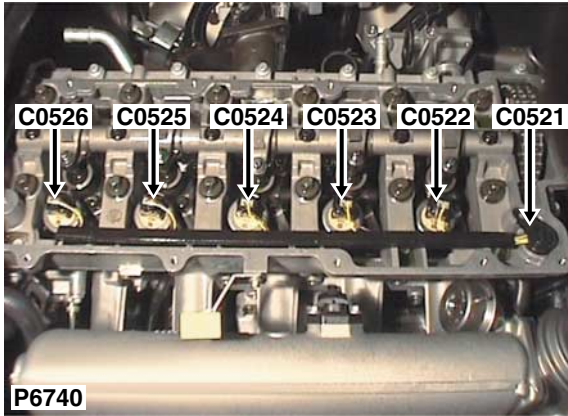

Cav	Col	Cct
1	Y	ALL
2	YN	ALL
4	YR	ALL
5	YP	ALL
6	YU	ALL
7	NO	ALL
8	NB	ALL

Description: *Injector harness to engine harness - Td5*

Location: *Top of engine*

NO CONNECTOR FACE

Colour: *BLACK*

Gender: *Female*

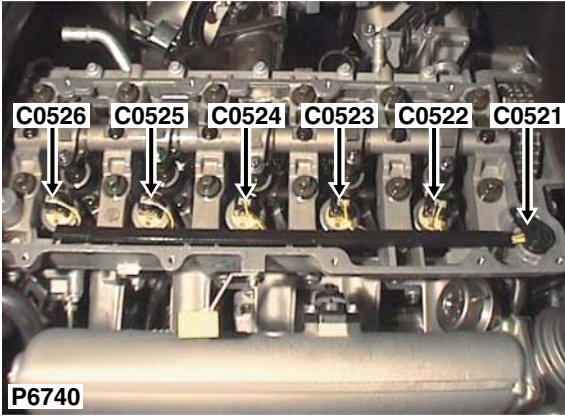

Cav	Col	Cct
1	Y	ALL
2	NB	ALL

Description: *Fuel injector - No. 1 - Td5*

Location: *Top of engine*

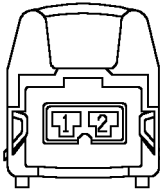

YPC115190

Colour: *BLACK*

Gender: *Female*

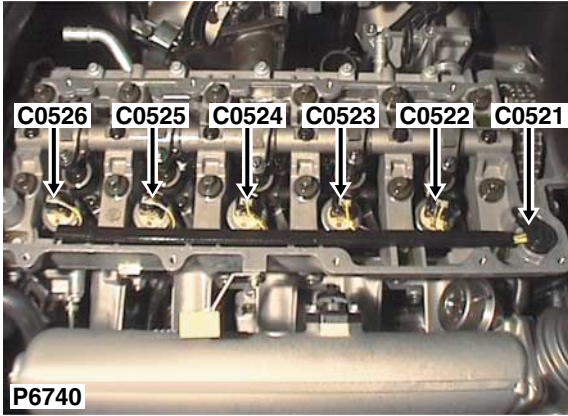

Cav	Col	Cct
1	YN	ALL
2	NO	ALL

Description: *Fuel injector - No. 2 - Td5*
Location: *Top of engine*

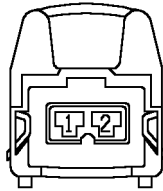

YPC115190

Colour: *BLACK*
Gender: *Female*

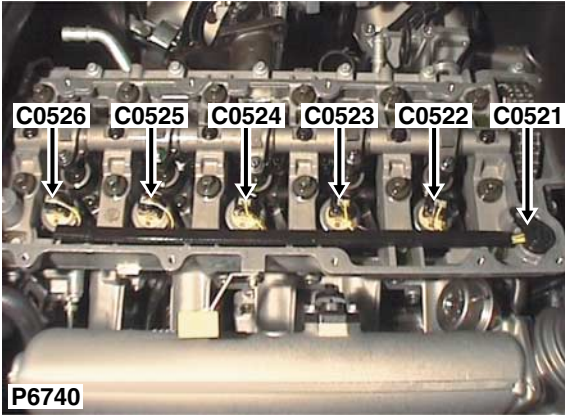

Cav	Col	Cct
1	YU	ALL
2	NB	ALL

Description: *Fuel injector - No. 3 - Td5*

Location: *Top of engine*

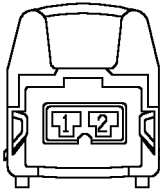

YPC115190

Colour: *BLACK*

Gender: *Female*

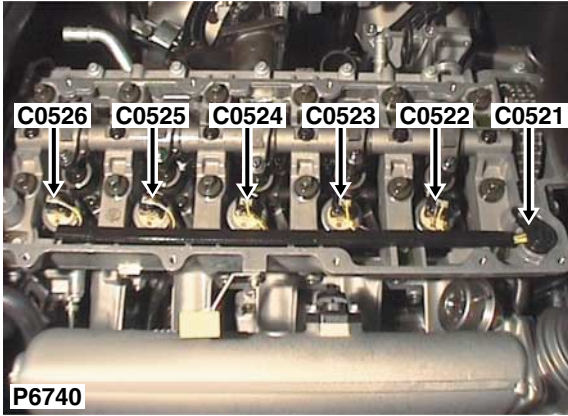

Cav	Col	Cct
1	YR	ALL
2	NB	ALL

Description: *Fuel injector - No. 4 - Td5*
 Location: *Top of engine*

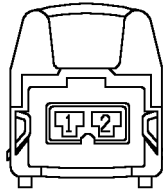

YPC115190

Colour: *BLACK*
 Gender: *Female*

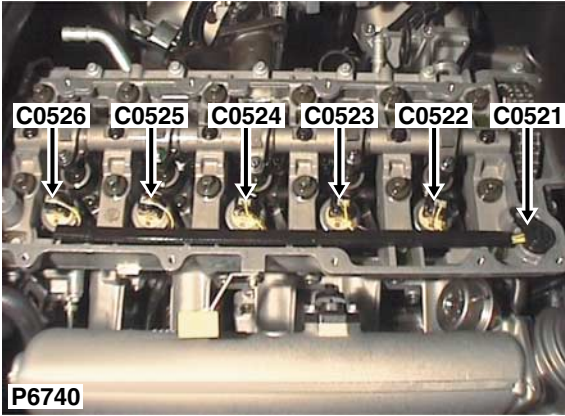

Cav	Col	Cct
1	YP	ALL
2	NO	ALL

Description: *Fuel injector - No. 5 - Td5*

Location: *Top of engine*

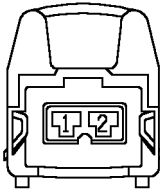

YPC115190

Colour: *BLACK*

Gender: *Female*

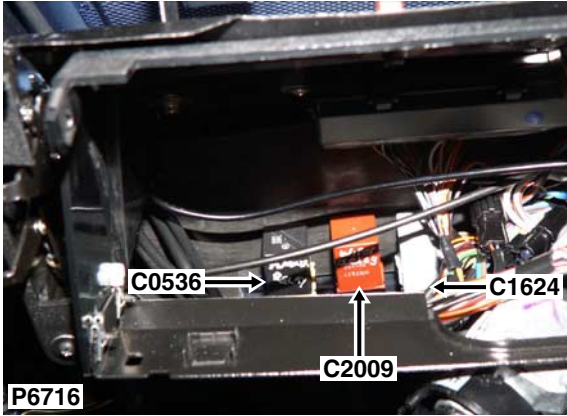

Cav	Col	Cct
2	LGP	2
4	B	2
6	LG	2
8	LGN	2

Description: *Relay - Direction indicator*
 Location: *Behind LH side of fascia*

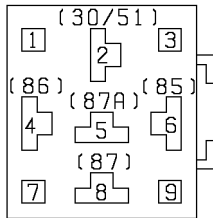

AFU4177

Colour: *BLACK*
 Gender: *Female*

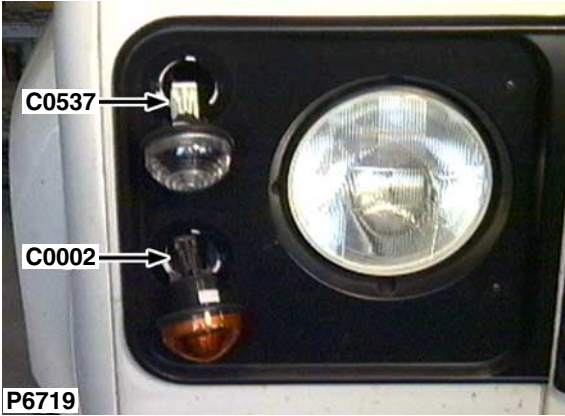

Cav	Col	Cct
1	B	ALL
2	RO	1
2	RB	42

Description: *Lamp - Side - Front - RH*
Location: *Behind RH front side lamp*

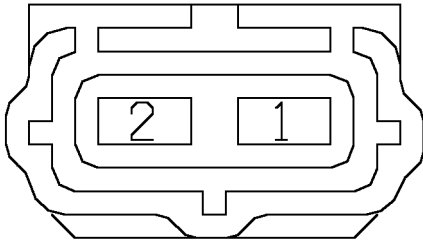

YPC10187

Colour: *WHITE*
Gender: *Female*

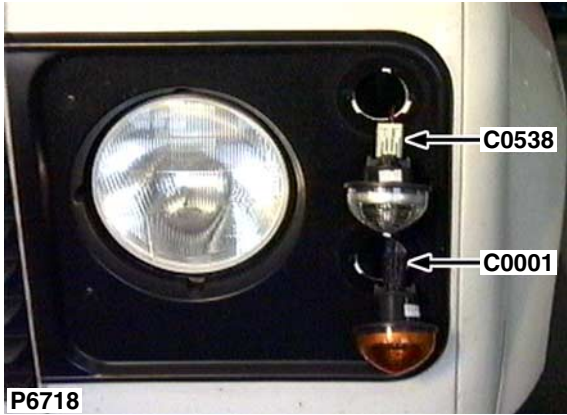

Cav	Col	Cct
1	B	ALL
2	RB	ALL

P6718

Description: *Lamp - Side - Front - LH*
 Location: *Behind LH front side lamp*

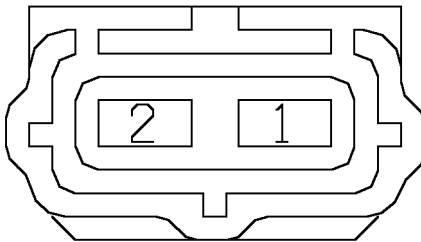

YPC10187

Colour: *WHITE*
 Gender: *Female*

C0543

CONNECTOR DETAILS

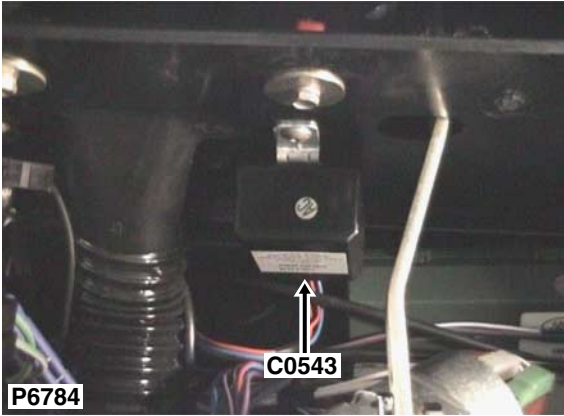

Cav	Col	Cct
1	B	3
2	UP	3
3	RY	3
4	BS	3

Description: *ECU - Lamp - Fog guard - Rear*

Location: *Behind instrument pack*

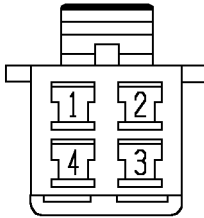

YPC10002

Colour: *NATURAL*

Gender: *Female*

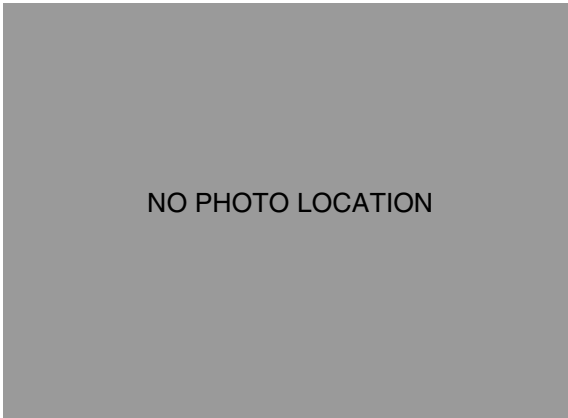

Cav	Col	Cct
2	LGP	3
4	B	3
6	LG	3
8	LGN	3

Description: *Unit - Direction indicator / hazard warning - RHD*
 Location: *Behind centre of fascia*

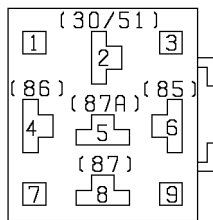

AFU4177

Colour: *BLACK*
 Gender: *Female*

C0550

CONNECTOR DETAILS

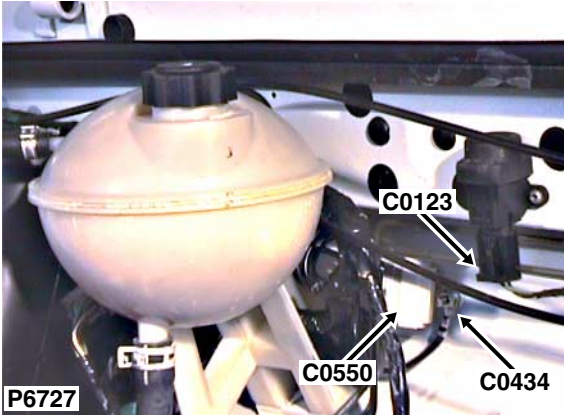

Cav	Col	Cct
1	B	ALL
2	B	ALL
3	B	ALL
4	B	ALL
5	B	ALL
6	B	ALL
7	B	ALL
8	B	ALL
9	B	ALL
10	B	25

Description: *Header - Earth*

Location: *Top of bulkhead - centre*

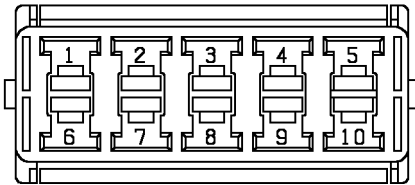

YPC10611

Colour: *LIGHT GREY*

Gender: *Female*

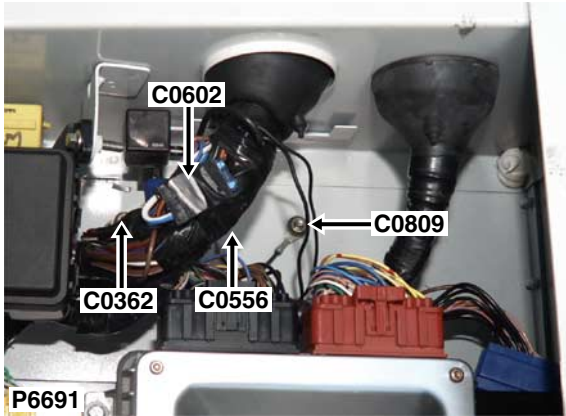

Cav	Col	Cct
1	B	4

Description: *Earth*

Location: *Beneath RH seat*

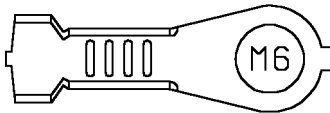

YPG10014

Colour: *TIN-PLATE*

Gender: *Eyelet*

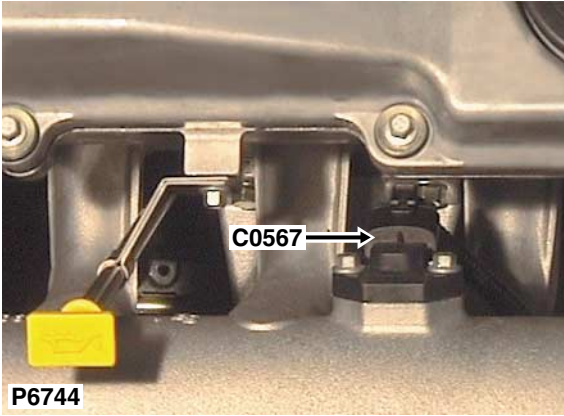

Cav	Col	Cct
1	KB	ALL
2	GB	ALL
3	KP	ALL
4	WY	ALL

Description: *Sensor - Inlet Air Temperature (IAT) and Manifold Absolute Pressure (MAP)*

Location: *Top of engine - RH side*

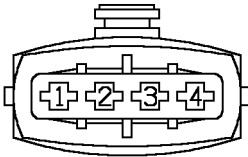

YPC110150

Colour: *BLACK*

Gender: *Female*

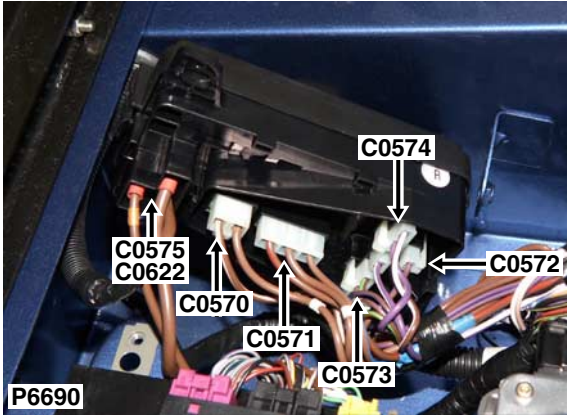

Cav	Col	Cct
1	NK	ALL
2	NW	ALL

Description: *Fuse box - Engine compartment*
 Location: *Beneath RH seat*

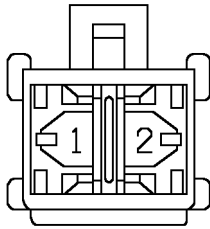

YPC10135

Colour: *NATURAL*
 Gender: *Female*

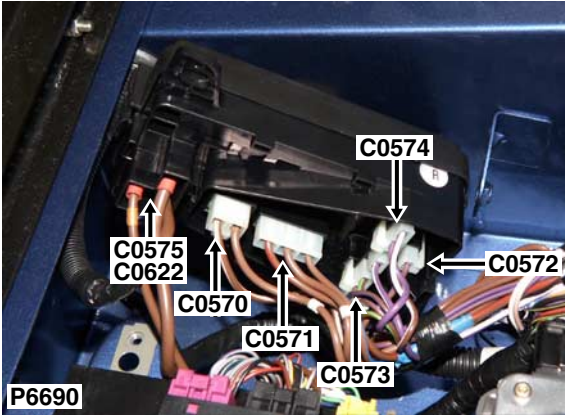

Cav	Col	Cct
1	NR	27
2	NW	4
3	NU	ALL

Description: Fuse box - Engine compartment

Location: Beneath RH seat

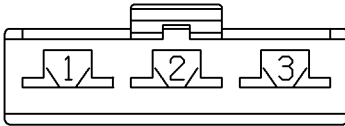

YPC10052

Colour: NATURAL

Gender: Female

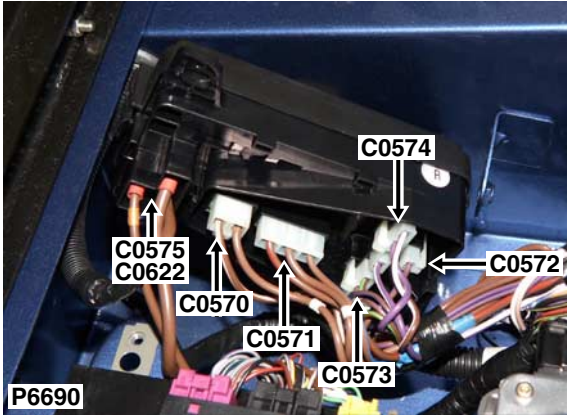

Cav	Col	Cct
1	NP	ALL

Description: *Fuse box - Engine compartment*
 Location: *Beneath RH seat*



YPC10007

Colour: *NATURAL*
 Gender: *Female*

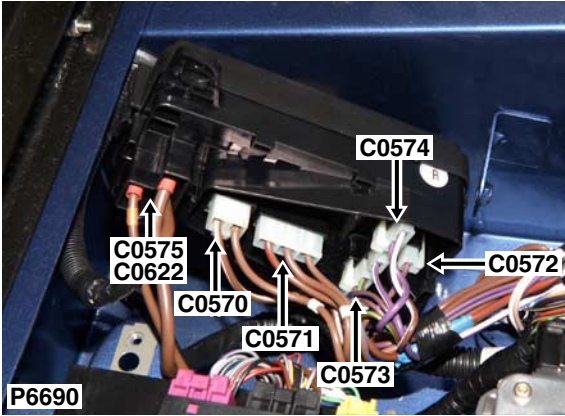

Cav	Col	Cct
1	PW	4
3	P	ALL
4	NW	4

Description: Fuse box - Engine compartment

Location: Beneath RH seat

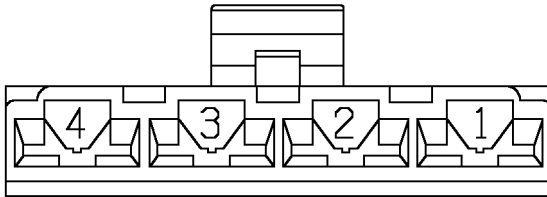

YPC10053

Colour: NATURAL

Gender: Female

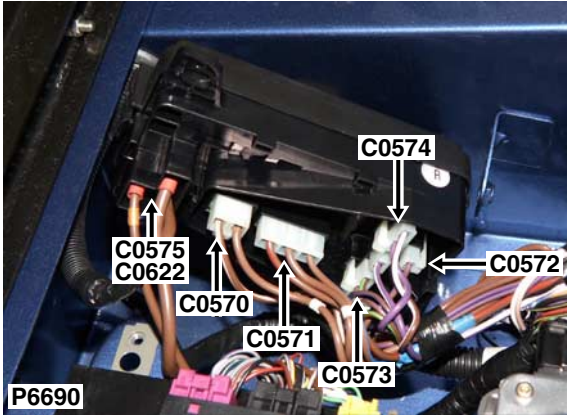

Cav	Col	Cct
1	PN	ALL
2	PN	ALL
3	NLG	4

Description: Fuse box - Engine compartment

Location: Beneath RH seat

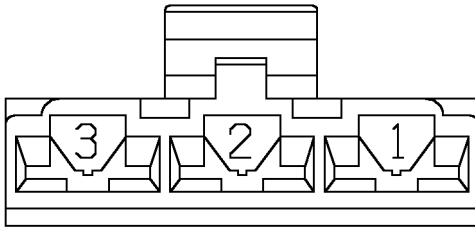

YPC10085

Colour: NATURAL

Gender: Female

Cav	Col	Cct
1	NO	26

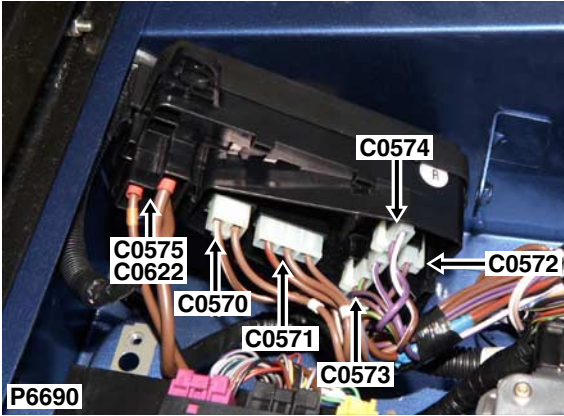

Description: Fuse box - Engine compartment

Location: Beneath RH seat

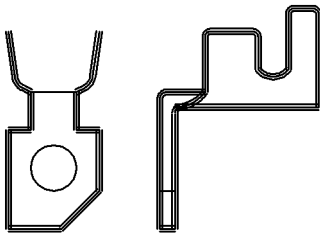

YPG100800

Colour: TIN-PLATE

Gender: Female

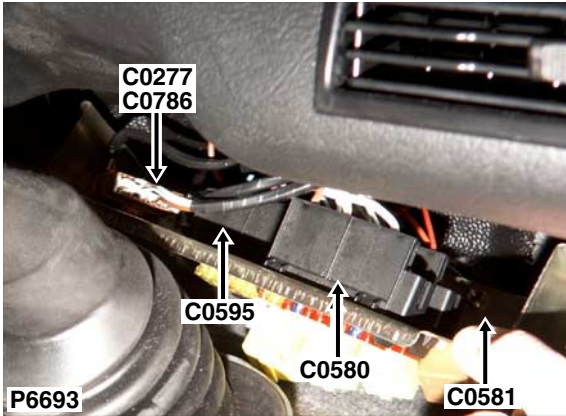

Description: *Fuse box - Passenger compartment*
 Location: *Behind centre of fascia*

Cav	Col	Cct
1	W	ALL
2	WG	19
4	WG	ALL
6	WG	ALL
8	GO	4
9	W	ALL
10	WG	ALL
12	GO	ALL
14	LGP	ALL
16	WG	ALL
17	WO	ALL
18	PG	ALL
20	WO	ALL

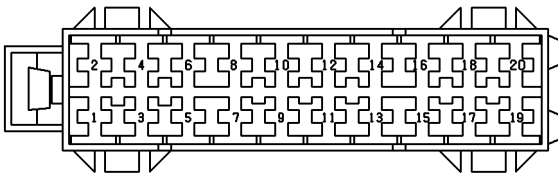

YQE102850

Colour: *BLACK*
 Gender: *Female*

C0581

CONNECTOR DETAILS

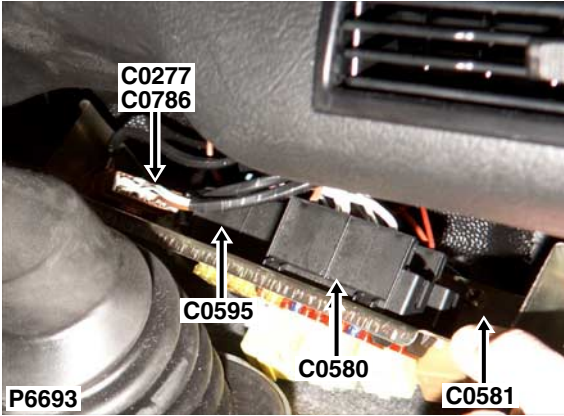

Description: *Fuse box - Passenger compartment*

Location: *Behind centre of fascia*

Cav	Col	Cct
1	R	ALL
2	RO	ALL
4	RB	ALL
6	RO	ALL
7	W	ALL
8	WG	ALL
9	UR	ALL
10	UB	ALL
12	UK	ALL
13	UW	ALL
14	UO	ALL
16	US	ALL
17	U	ALL
18	UP	ALL
19	PB	19
20	OR	19

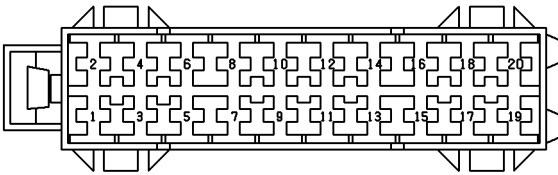

YQE102850

Colour: *BLACK*

Gender: *Female*

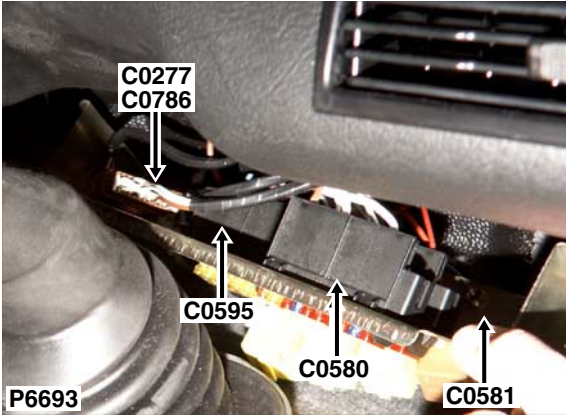

Description: *Fuse box - Passenger compartment*
 Location: *Behind centre of fascia*

Cav	Col	Cct
1	NK	ALL
2	NP	25
4	NS	25
6	PN	ALL
8	PN	ALL
9	NK	ALL
10	NO	ALL
11	NS	27
12	LGW	26
14	SO	27
16	RG	27
17	NO	26
18	NP	26

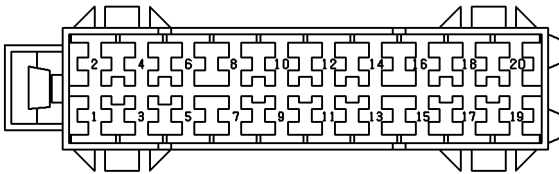

YQE102850

Colour: *BLACK*
 Gender: *Female*

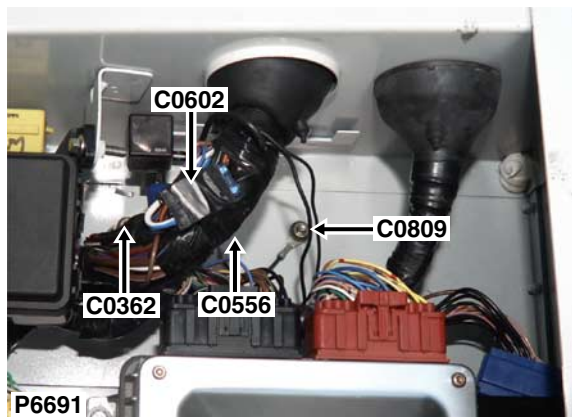

Cav	Col	Cct
1	NO	4
2	N	4

Description: *Holder - Fuse*
 Location: *Beneath RH seat*

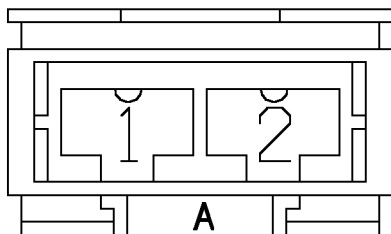

ADU7900

Colour: *BLACK*
 Gender: *Female*

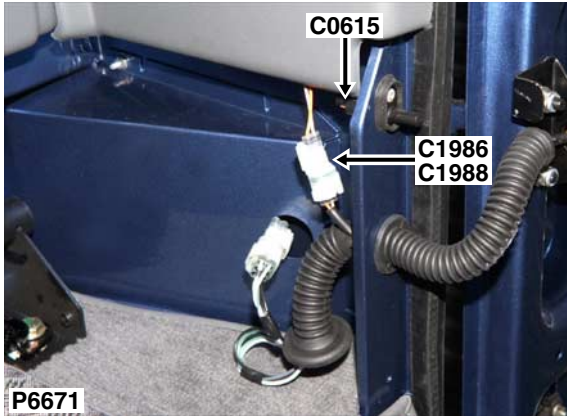

Cav	Col	Cct
1	PU	24

Description: *Switch - Boot / tail door*
 Location: *Behind RH rear trim panel*

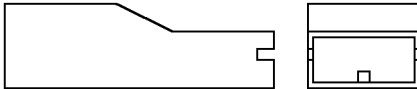

AAU1010

Colour: *BLACK*
 Gender: *Female*

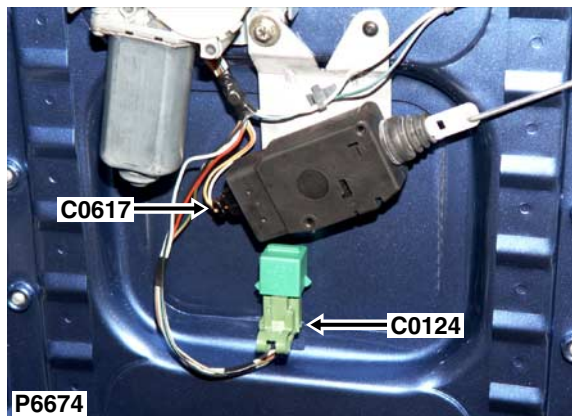

Cav	Col	Cct
1	O	19
2	K	19

Description: *Motor - Lock - Tail door*

Location: *Centre of taildoor, behind trim panel*

NO CONNECTOR FACE

Colour: *BLACK*

Gender: *Female*

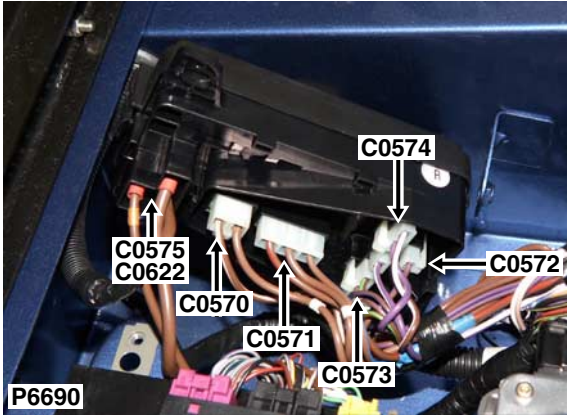

Cav	Col	Cct
1	N	ALL

Description: Fuse box - Engine compartment - Td5
 Location: Beneath RH seat

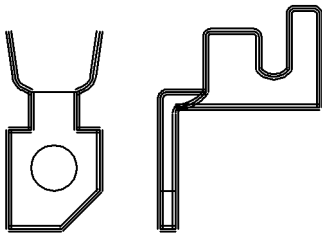

YPG100800

Colour: TIN-PLATE
 Gender: Female

C0658

CONNECTOR DETAILS

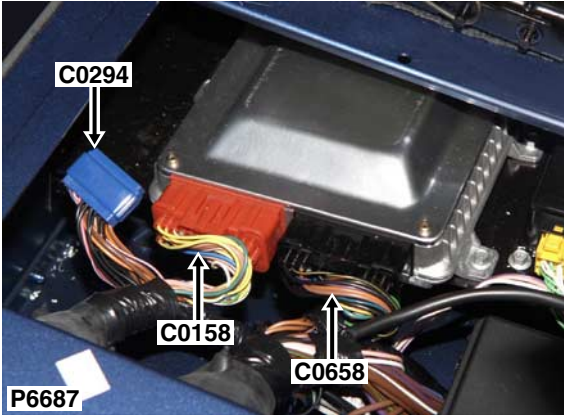

Description: Engine control module (ECM)

Location: Beneath RH seat

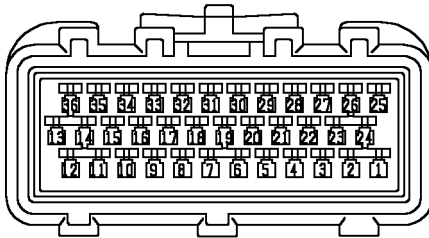

YPC10073

Colour: BLACK

Gender: Female

Cav	Col	Cct
1	B	4
2	B	4
3	NO	4
4	BP	4
5	UP	4
6	RS	ALL
7	GU	ALL
9	YS	4
12	WG	ALL
13	YK	ALL
14	WP	ALL
16	GP	4
18	K	4
19	YK	4
19	WS	ALL
20	RG	ALL
21	UR	4
22	NO	4
23	PB	4
24	B	4
25	B	4
26	BY	ALL
27	NO	4
29	BS	4
30	BY	ALL
32	SP	4
33	WG	4
34	LGS	ALL
35	BW	ALL
36	WS	ALL

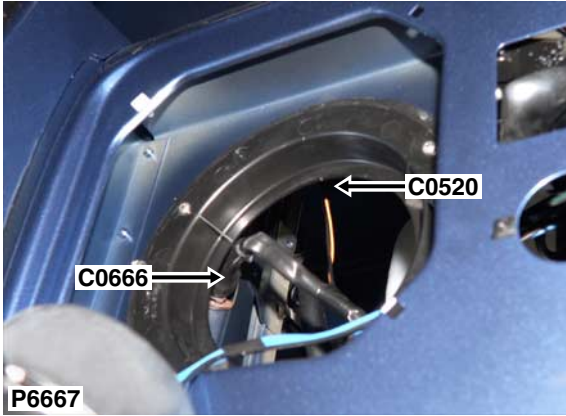

Cav	Col	Cct
1	B	37
2	B	37
3	B	37
4	B	37

Description: *Sounder - Alarm - Battery backed up*
 Location: *Behind LH headlamp*

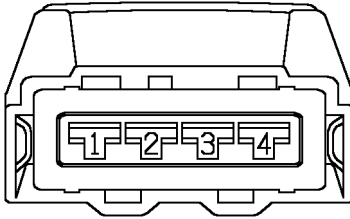

YPC108930

Colour: *BROWN*
 Gender: *Female*

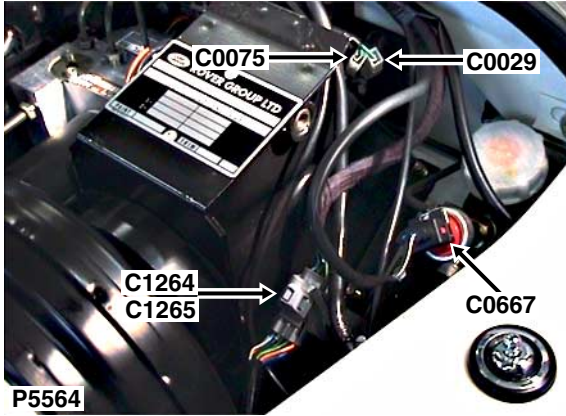

Cav	Col	Cct
1	BW	6
2	B	6

Description: *Switch - Clutch pedal*
 Location: *Adjacent pedal box*

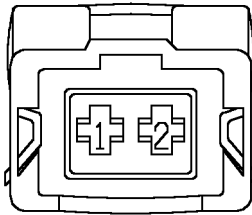

YPC107790

Colour: *BLACK*
 Gender: *Female*

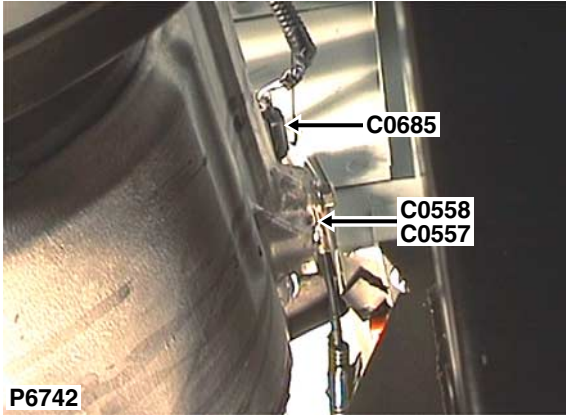

Cav	Col	Cct
1	WB	ALL
3	B	ALL

Description: *Switch - Transmision - High-Low*
 Location: *LH side of transfer box*

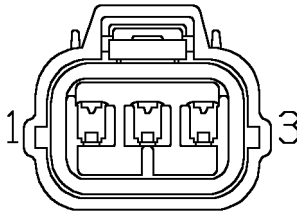

YPC10181

Colour: *LIGHT GREY*
 Gender: *Female*

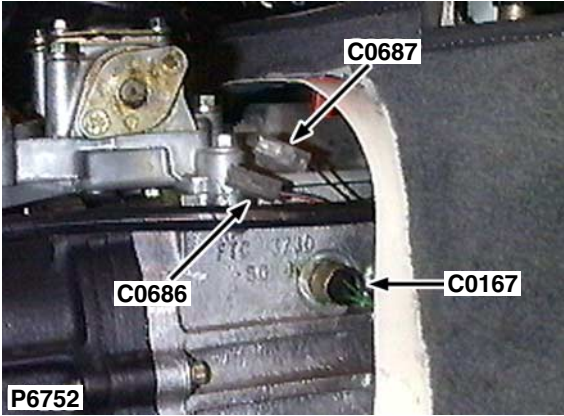

Cav	Col	Cct
1	SR	ALL

Description: *Switch - Temperature - Transmission oil*
Location: *LH side of gearbox*

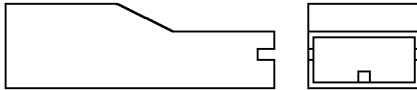

AAU1010

Colour: *BLACK*
Gender: *Female*

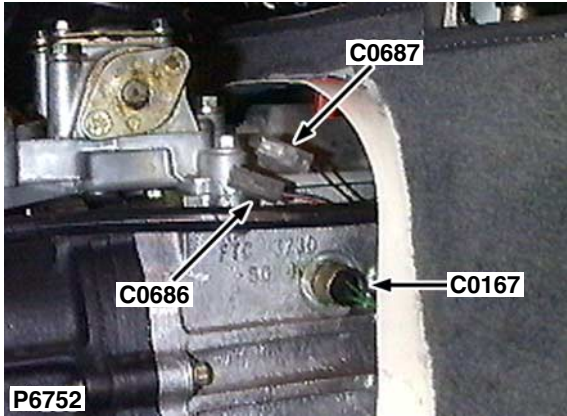

Cav	Col	Cct
1	B	ALL

Description: *Switch - Temperature - Transmission oil*
 Location: *LH side of gearbox*

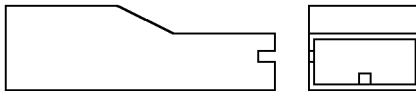

AAU1010

Colour: *BLACK*
 Gender: *Female*

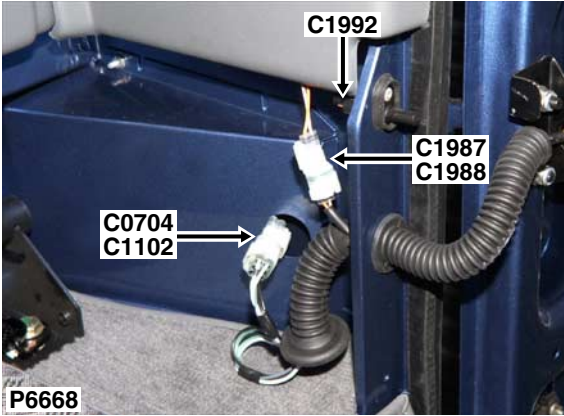

Cav	Col	Cct
1	WB	ALL
2	GP	ALL
3	BG	ALL
4	WG	ALL
6	B	ALL

Description: *Chassis harness to tail door harness*

Location: *Behind RH rear trim panel*

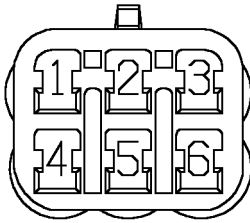

AFU3563

Colour: *NATURAL*

Gender: *Female*

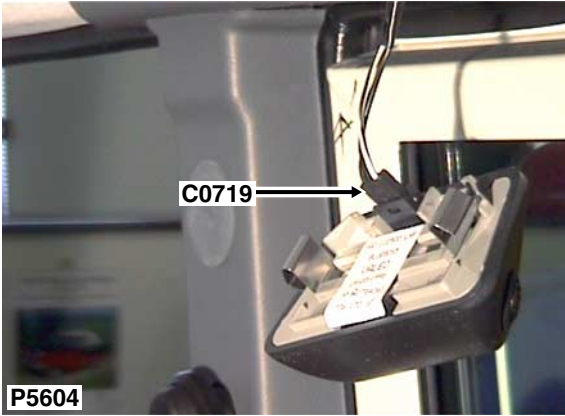

Cav	Col	Cct
1	BN	33
2	B	33
3	WB	33

Description: *Sensor - Volumetric*
Location: *Behind headlining top of RH 'B' post*

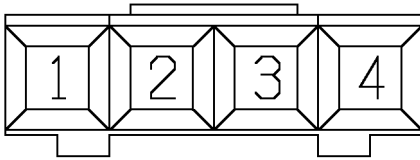

YPC10199

Colour: *BLACK*
Gender: *Female*

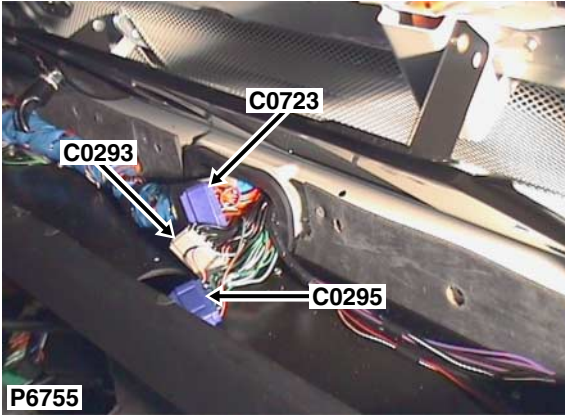

Description: *Header*

Location: *Behind centre of fascia*

Cav	Col	Cct
1	RO	2
2	RO	28
3	RO	28
4	RO	2
6	RO	40
7	RO	40
8	RO	2
9	B	2
10	B	2
11	B	20
12	B	2
13	RO	2
16	RO	2
17	RO	40
18	RO	40

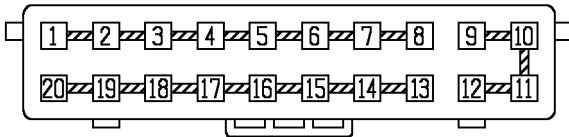

YQC10002

Colour: *GREY*
 Gender: *Female*

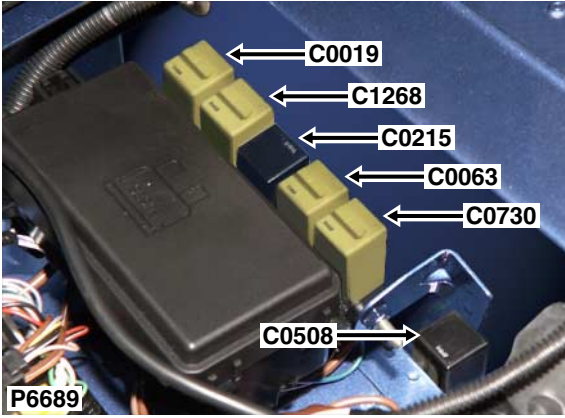

Cav	Col	Cct
30	WP	4
85	UP	4
86	NO	4
87	PW	4

Description: *Relay - Fuel pump*

Location: *Beneath RH seat*

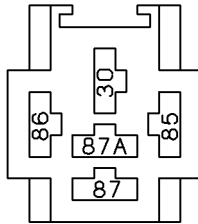

AFU3271

Colour: *YELLOW*

Gender: *Female*

C0731

CONNECTOR DETAILS

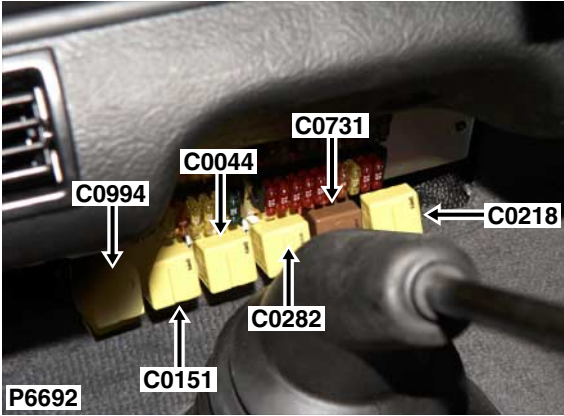

Cav	Col	Cct
87A	OR	19
30	OB	19
85	PN	19
86	OW	ALL
87	PN	19

Description: *Relay - Sounder - Alarm*

Location: *Behind centre of fascia*

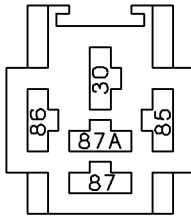

YPP10004

Colour: *BROWN*

Gender: *Female*

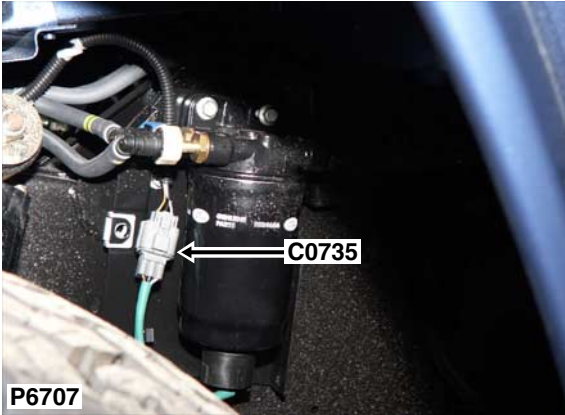

Cav	Col	Cct
1	OG	11
2	B	11
3	WG	11

P6707

Description: *Sensor - Water filter*

Location: *Below RH rear wheelarch*

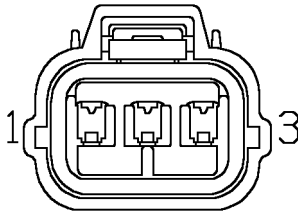

YPC10181

Colour: *LIGHT GREY*

Gender: *Female*

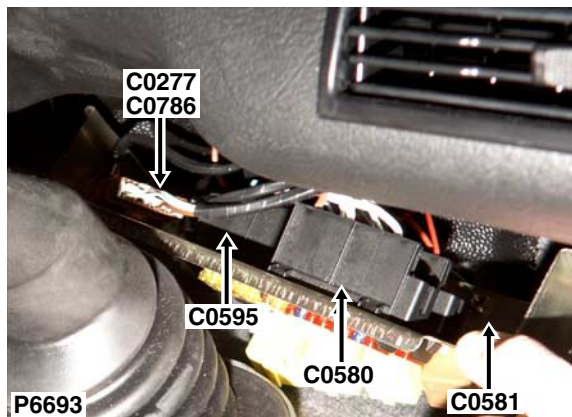

Cav	Col	Cct
1	WG	25
3	YS	4
3	BS	7
4	PB	4
4	BP	7
6	NP	25
7	B	25

Description: *Main harness to air conditioning (A/C) harness*

Location: *Behind centre of fascia*

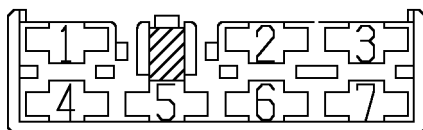

YPC10473

Colour: *BROWN*

Gender: *Female*



Cav	Col	Cct
B	WP	6
C	RG	6
D	BY	6
F	WG	6
G	BY	6
J	WP	6
K	WS	6

Description: *Switch - Throttle pedal*
 Location: *Behind driver side of fascia*

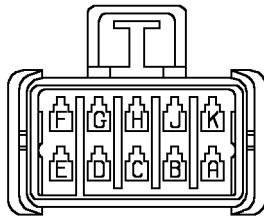

YPC111870

Colour: *BLACK*
 Gender: *Female*

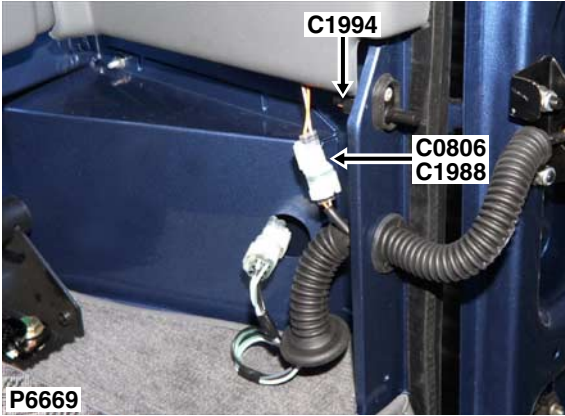

Cav	Col	Cct
1	K	44
2	O	44

Description: *Lamp - Interior - Rear*

Location: *Behind RH rear trim panel*

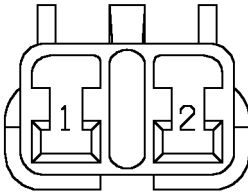

AFU3635

Colour: *NATURAL*

Gender: *Female*

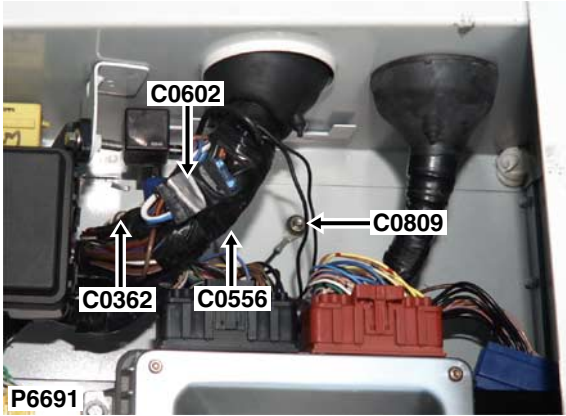

Cav	Col	Cct
1	B	26

Description: *Earth*

Location: *Beneath RH seat*

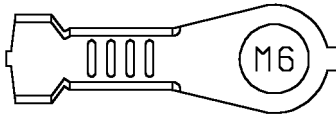

YPG10013

Colour: *TIN-PLATE*

Gender: *Female*

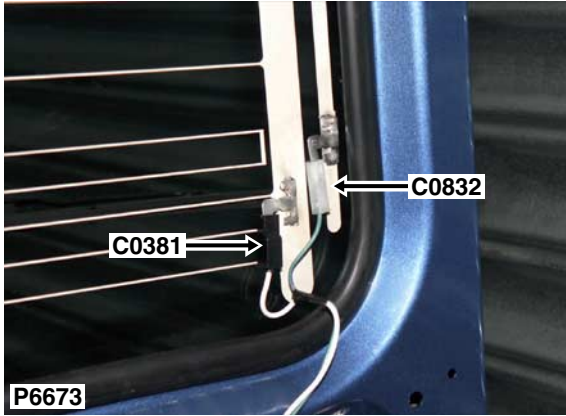

Cav	Col	Cct
1	GP	1

Description: *Lamp - brake - high mounted*
Location: *LH side of taildoor*

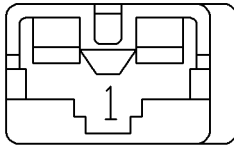

AFU4521

Colour: *NATURAL*
Gender: *Female*

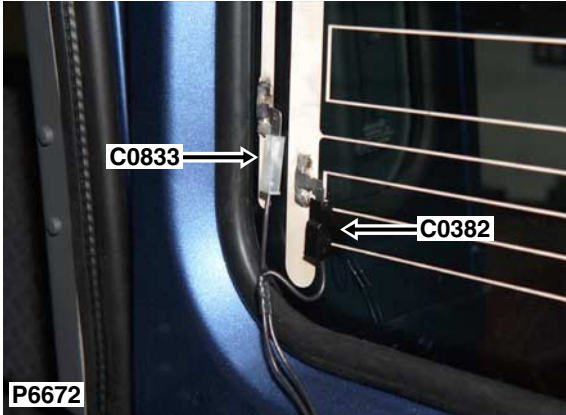

Cav	Col	Cct
1	B	1

Description: *Lamp - brake - high mounted*
Location: *RH side of tail door*

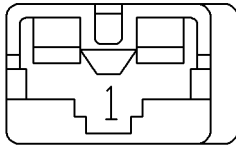

AFU4521

Colour: *NATURAL*
Gender: *Female*

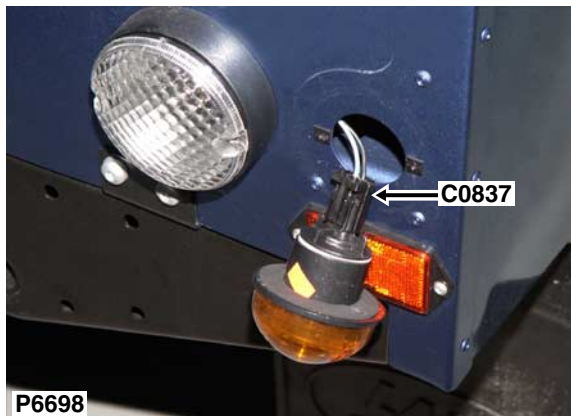

Cav	Col	Cct
1	B	ALL
2	GW	ALL

Description: *Lamp - Direction indicator / hazard warning - Rear - RH*
 Location: *RH rear of vehicle*

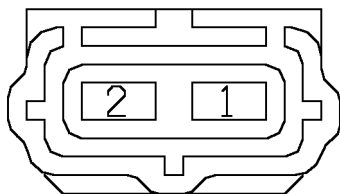

YPC10070

Colour: *BLACK*
 Gender: *Female*

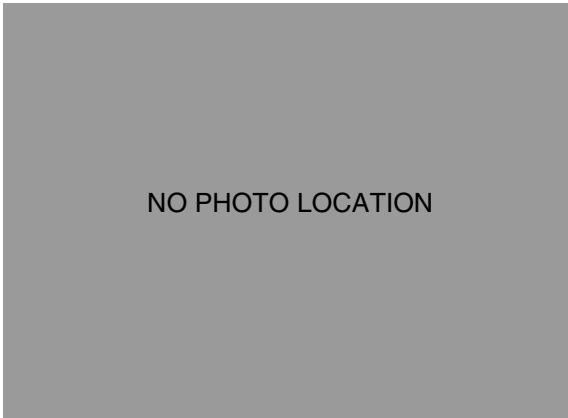

Cav	Col	Cct
1	WK	25
2	BS	25

Description: *Switch - Clutch - Air conditioning (A/C) - 300 TDi*
 Location: *Front RH side of engine*

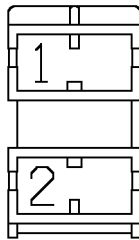

YPC107190

Colour: *GREEN*
 Gender: *Female*

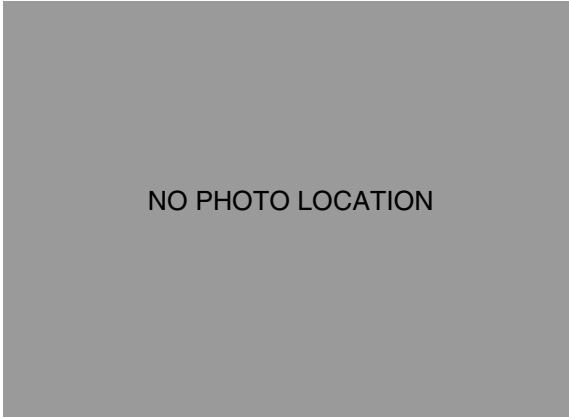

Cav	Col	Cct
1	BP	25
2	B	25

Description: *Switch - Fan - Air conditioning (A/C) - 300 TDi*
Location: *Front RH side of engine*

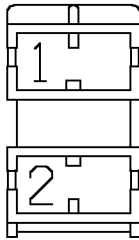

YPC107200

Colour: *YELLOW*
Gender: *Female*

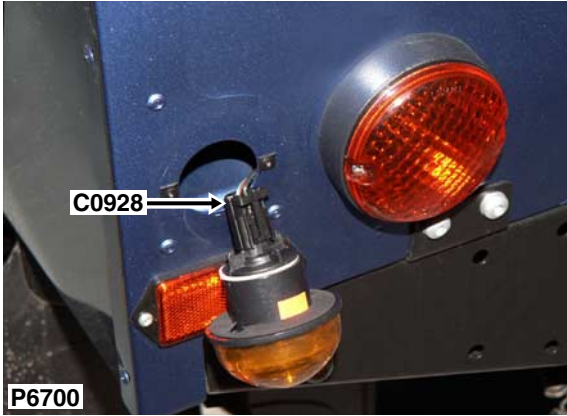

Cav	Col	Cct
1	B	ALL
2	GR	ALL

Description: *Lamp - Direction indicator / hazard warning - Rear - LH*
 Location: *LH rear of vehicle*

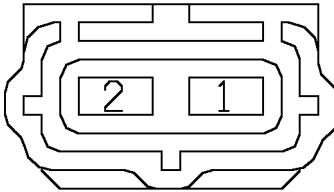

YPC10070

Colour: *BLACK*
 Gender: *Female*

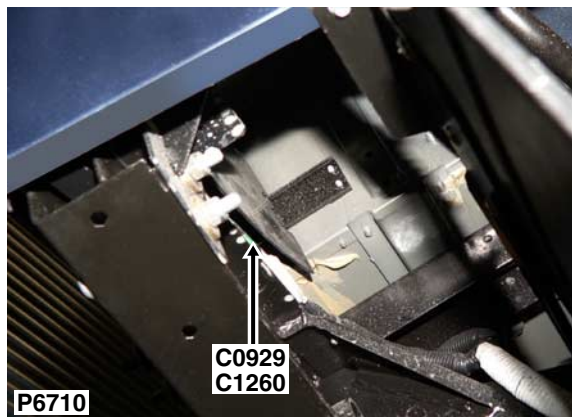

Description: *Trailer pick-up*

Location: *Below RH rear wheelarch*

Cav	Col	Cct
1	GR	ALL
2	RB	ALL
3	GW	ALL
4	RO	ALL
5	GP	ALL
6	P	ALL
7	GN	ALL
8	RY	ALL
9	B	ALL

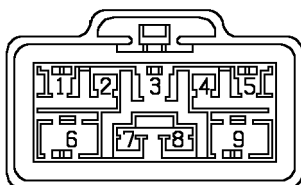

YPC114850

Colour: *GREY*

Gender: *Female*

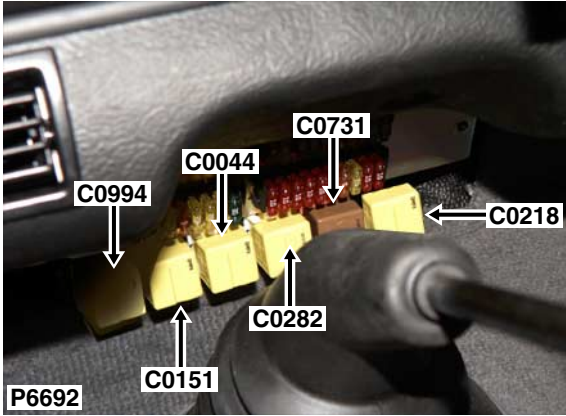

Cav	Col	Cct
30	NP	26
85	PY	26
86	B	26
87	PS	26

Description: *Relay - Heated front screen*

Location: *Behind centre of fascia*

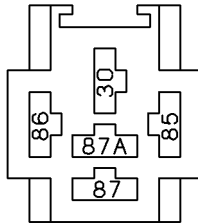

AFU3271

Colour: *YELLOW*

Gender: *Female*

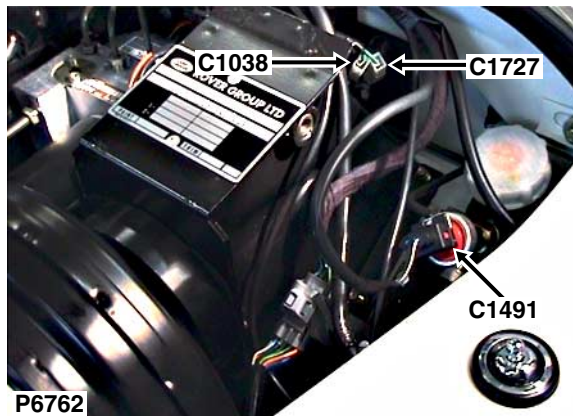

Cav	Col	Cct
1	GO	2

Description: *Switch - Brake pedal*

Location: *Adjacent pedal box*

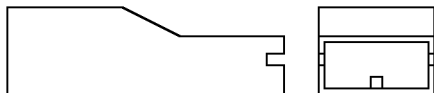

ADU8339

Colour: *NATURAL*

Gender: *Female*

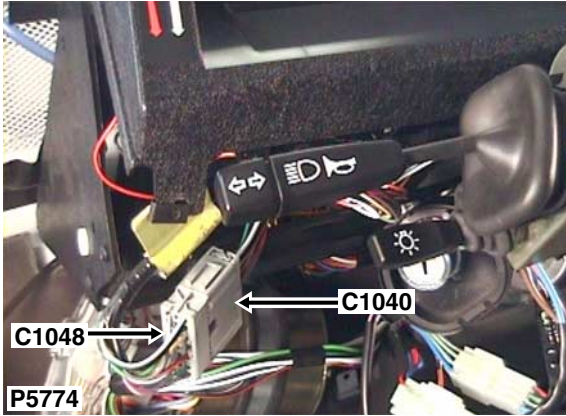

Description: *Main harness to instrument pack harness*
 Location: *Behind instrument pack*

Cav	Col	Cct
1	WG	3
2	B	3
3	YK	6
4	RO	3
5	GB	3
6	PN	3
7	SB	3
8	GU	ALL
9	B	3
10	BR	3
11	PN	21
12	WO	3
13	K	21
14	WS	6

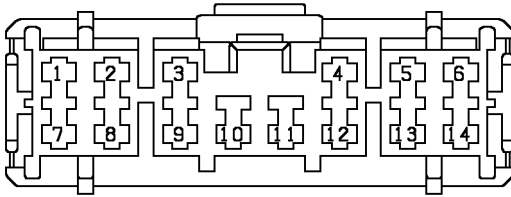

YPC10495

Colour: *LIGHT GREY*
 Gender: *Female*

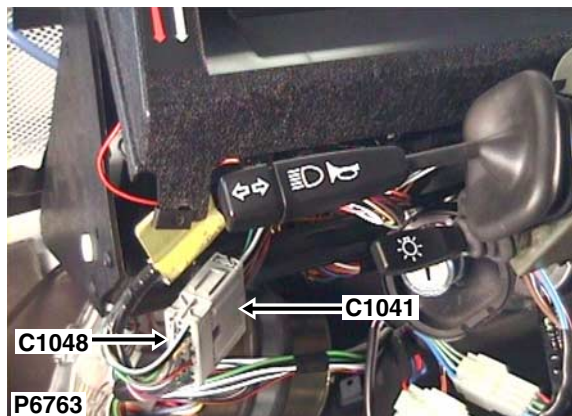

Description: *Main harness to instrument pack harness*

Location: *Behind instrument pack*

Cav	Col	Cct
1	WG	2
2	B	2
3	YK	ALL
4	RO	2
5	GB	2
6	PN	2
7	SB	2
8	GU	ALL
9	B	2
10	BR	2
11	PN	20
12	WO	2
13	K	20
14	WS	5

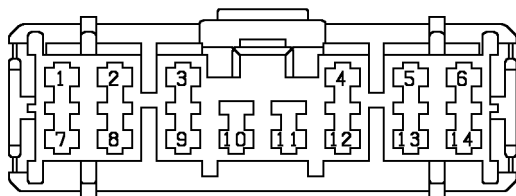

YPC10495

Colour: *LIGHT GREY*

Gender: *Female*

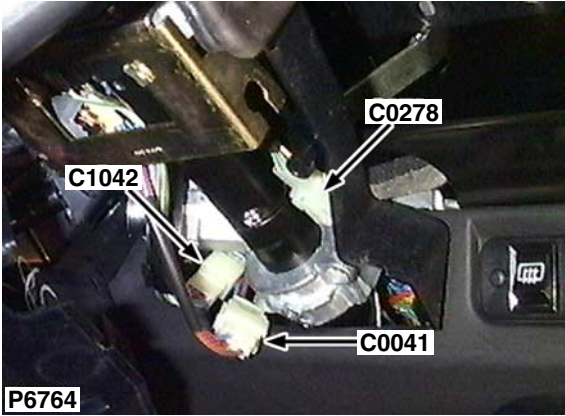

Cav	Col	Cct
1	U	ALL
2	GW	3
3	LGN	3
4	GR	3
5	UW	3
6	UR	ALL
7	NP	3
8	PB	3

Description: *Switch - Horn / Dim dip*
 Location: *Behind steering column cowl LH side*

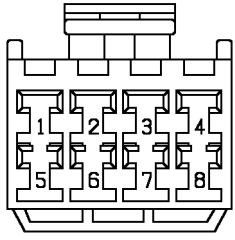

AFU3574

Colour: *NATURAL*
 Gender: *Female*

C1043

CONNECTOR DETAILS

Cav	Col	Cct
1	NW	2

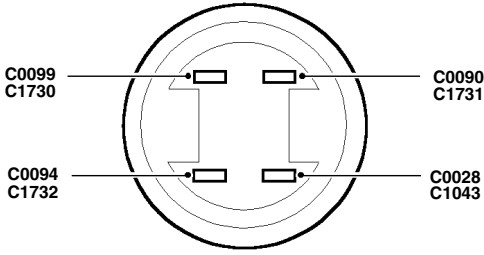

Description: *Switch - Ignition*

Location: *Behind instrument pack*

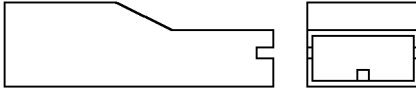

AAU1010

Colour: *BLACK*

Gender: *Female*

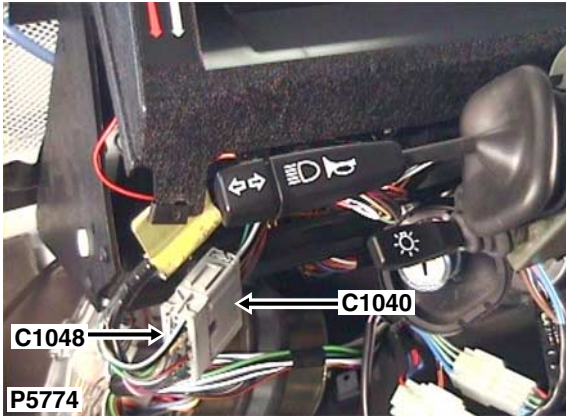

Description: *Instrument pack harness to main harness*
 Location: *Behind instrument pack*

Cav	Col	Cct
1	WG	ALL
2	B	ALL
3	YK	ALL
4	RO	ALL
5	GB	ALL
6	PN	ALL
7	SB	ALL
8	LGU	4
8	GU	7
9	B	ALL
10	BR	ALL
11	NU	ALL
12	WO	ALL
13	K	ALL
14	WS	41

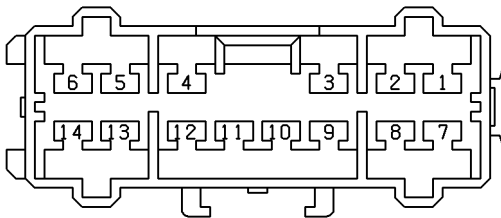

YPC10592

Colour: *LIGHT GREY*
 Gender: *Male*

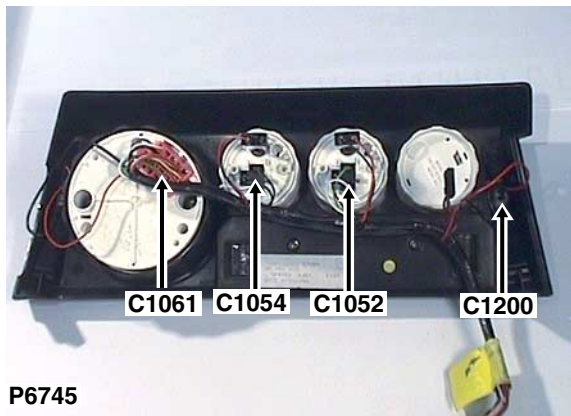

Cav	Col	Cct
1	B	ALL
2	LGU	ALL
3	WG	ALL

P6745

Description: *Gauge - Coolant temperature*

Location: *Behind instrument pack*

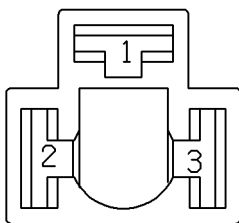

YPC114046

Colour: *BLACK*

Gender: *Female*

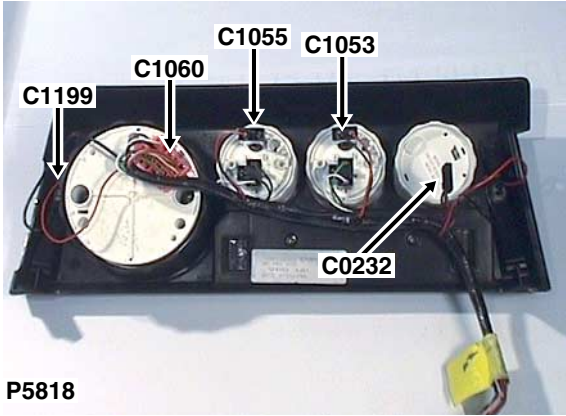

Cav	Col	Cct
1	RO	ALL
2	B	ALL

P5818

Description: *Gauge - Coolant temperature*

Location: *Behind instrument pack*

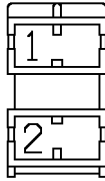

ADU8885

Colour: *BLACK*
 Gender: *Female*

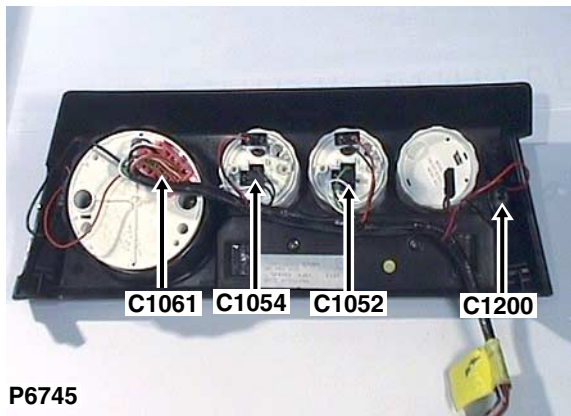

Cav	Col	Cct
1	B	ALL
2	LGB	ALL
3	WG	ALL

P6745

Description: *Gauge - Fuel*

Location: *Behind instrument pack*

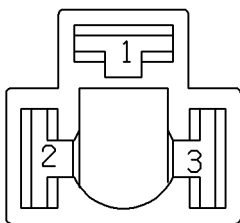

YPC114046

Colour: *BLACK*

Gender: *Female*

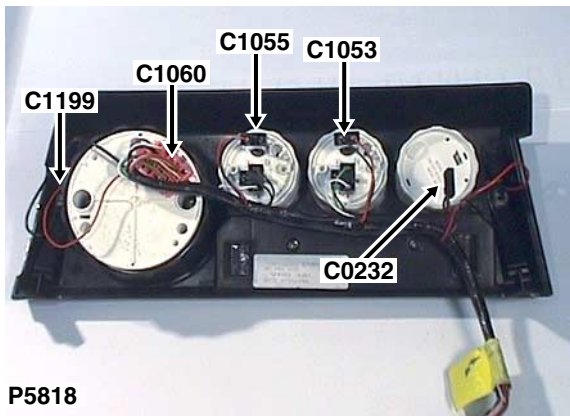

Cav	Col	Cct
1	RO	ALL
2	B	ALL

P5818

Description: *Gauge - Fuel*

Location: *Behind instrument pack*

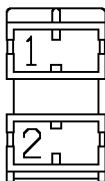

ADU8885

Colour: *BLACK*

Gender: *Female*

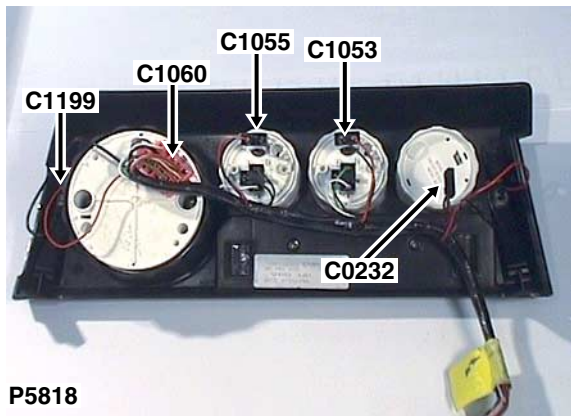

P5818

Description: *Speedometer*

Location: *Behind instrument pack*

Cav	Col	Cct
1	YK	ALL
2	BR	ALL
3	K	ALL
4	RO	ALL
6	NU	ALL
7	B	ALL
9	PN	ALL
10	WG	ALL

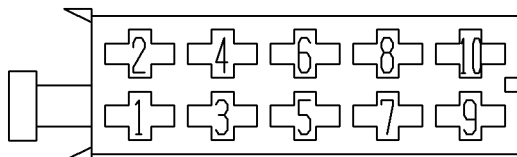

YPC10192

Colour: *RED*

Gender: *Female*

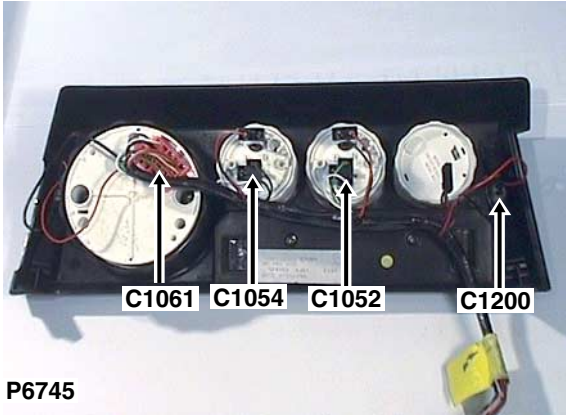

Cav	Col	Cct
1	WO	ALL
3	GB	ALL
5	GU	7
7	LGB	ALL
9	LGU	7

P6745

Description: *Speedometer*

Location: *Behind instrument pack*

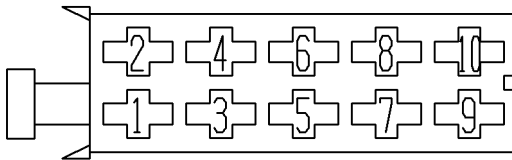

YPC10192

Colour: *RED*
 Gender: *Female*

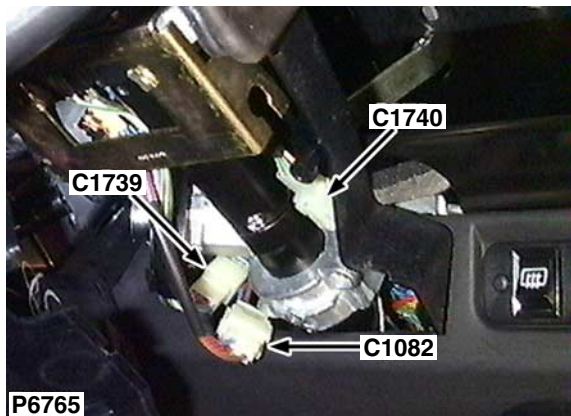

Cav	Col	Cct
1	NU	20
2	R	2
4	U	2

Description: *Switch - Lighting*

Location: *Behind steering column cowl LH side*

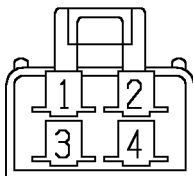

AFU3855

Colour: *NATURAL*

Gender: *Female*

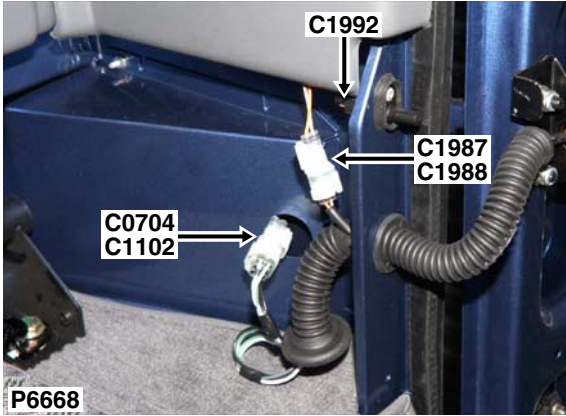

Cav	Col	Cct
1	WB	1
2	GP	1
3	BG	1
4	WG	1
6	B	1

Description: *Tail door harness to chassis harness*
 Location: *Behind RH rear trim panel*

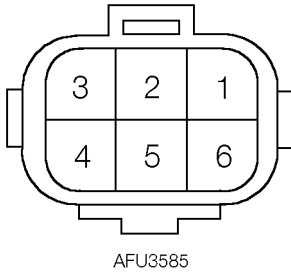

Colour: *NATURAL*
 Gender: *Male*

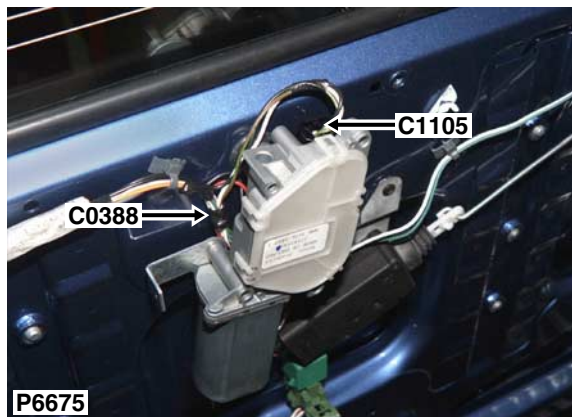

Cav	Col	Cct
1	NLG	1
2	WG	1
3	B	1

Description: *Switch - Park - Rear wiper*

Location: *RH side of taildoor, behind trim panel*

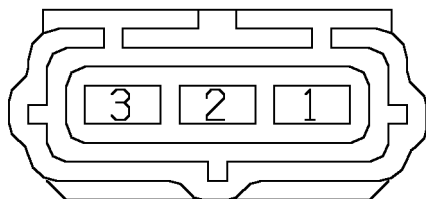

YPC10068

Colour: *BLACK*

Gender: *Female*

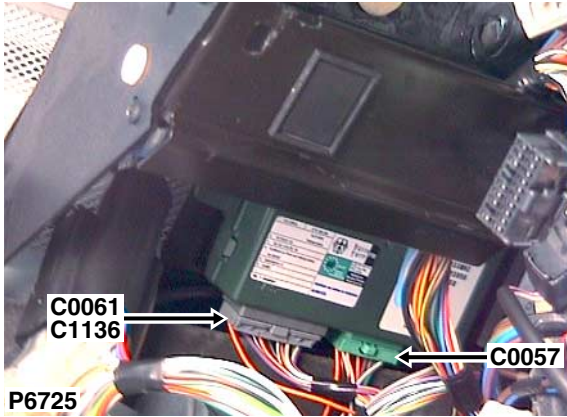

Cav	Col	Cct
1	OS	21

Description: *Aerial*

Location: *Behind instrument pack*

NO CONNECTOR FACE

Colour:

Gender:

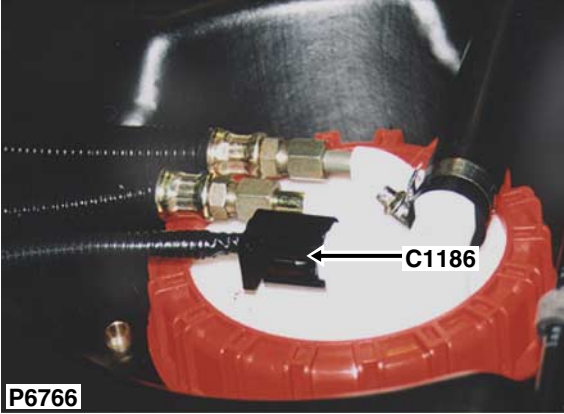

Cav	Col	Cct
1	GB	15
2	SB	15
3	B	15

Description: *Fuel tank*

Location: *Above fuel tank*

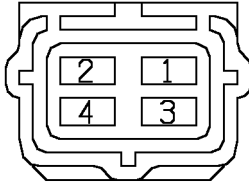

YPC10066

Colour: *BLACK*

Gender: *Female*

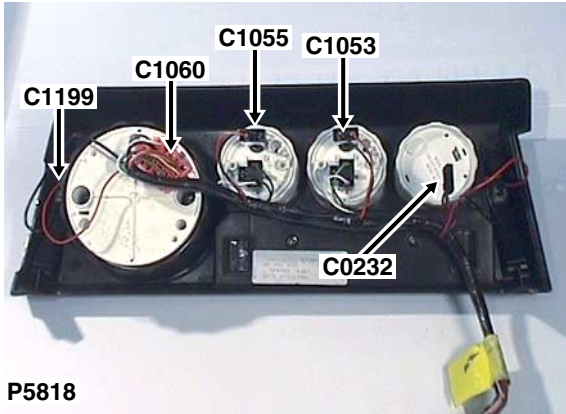

P5818

Description: *Heater control illumination*

Location: *Behind instrument pack*

Cav	Col	Cct
1	RO	ALL

NO CONNECTOR FACE

Colour: *BRASS, TIN-PLATED*

Gender: *Female*

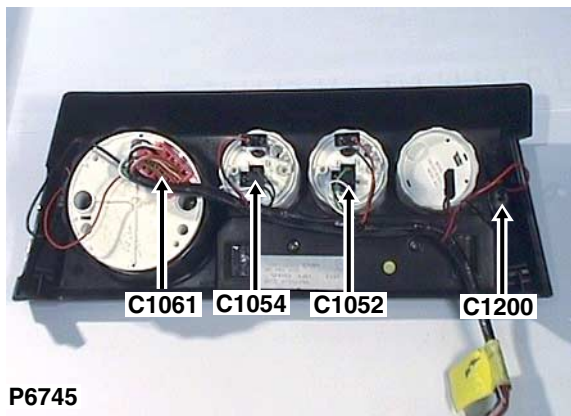

Cav	Col	Cct
1	RO	ALL

P6745

Description: *Heater control illumination*

Location: *Behind instrument pack*

NO CONNECTOR FACE

Colour: *BRASS, TIN-PLATED*

Gender: *Female*

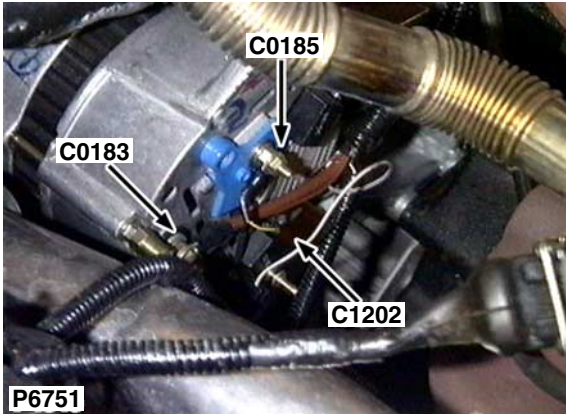

Cav	Col	Cct
1	WG	41
1	WS	ALL

Description: *Tachometer - 300 TDi*
 Location: *LH side of engine*

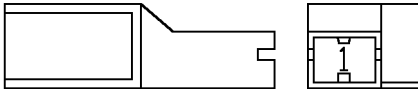

YPC10165

Colour: *BLACK*
 Gender: *Female*

C1209

CONNECTOR DETAILS

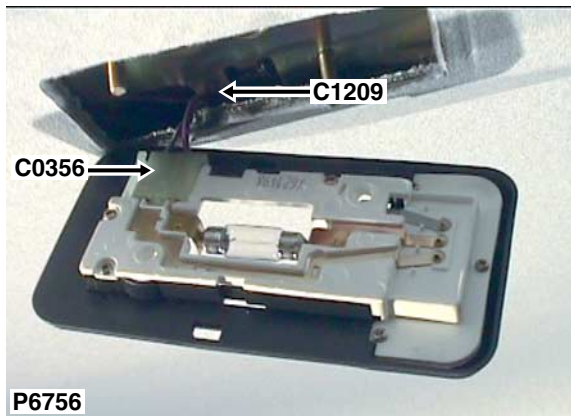

Cav	Col	Cct
1	B	44

Description: *Earth*

Location: *Rear of headlining*

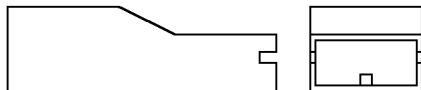

AAU1010

Colour: *BLACK*

Gender: *Female*

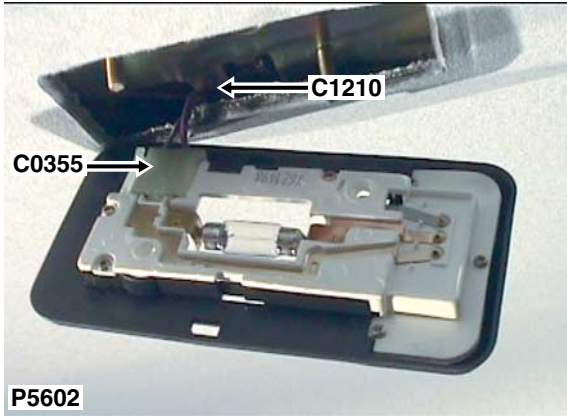

Cav	Col	Cct
1	B	ALL

Description: *Earth*

Location: *Front of headlining in the centre*

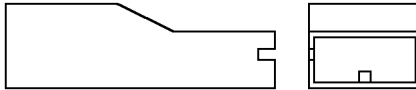

AAU1010

Colour: *BLACK*

Gender: *Female*

C1260

CONNECTOR DETAILS

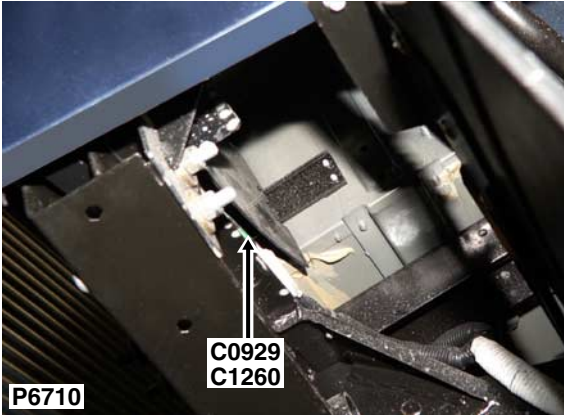

Cav	Col	Cct
1	GR	ALL
2	RB	ALL
3	GW	ALL
4	RO	ALL
5	GP	ALL
6	P	ALL
7	GN	ALL
8	RY	ALL
9	B	ALL

Description: *Trailer pick-up*

Location: *Below RH rear wheelarch*

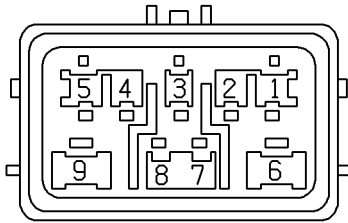

PC114860

Colour: *DARK GREY*

Gender: *Male*

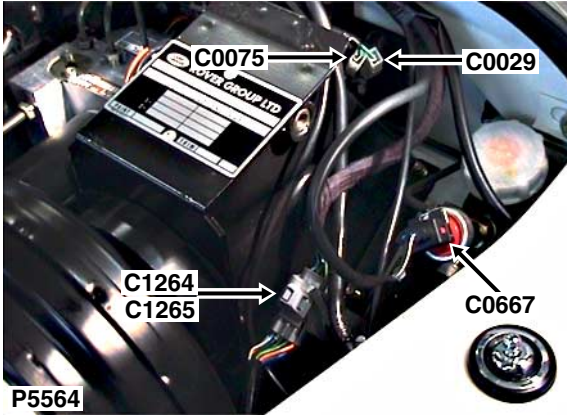

Description: *Main harness to wing harness*
 Location: *Adjacent pedal box*

Cav	Col	Cct
1	US	ALL
2	UK	ALL
3	B	ALL
4	GR	ALL
5	RB	ALL
6	PB	ALL
7	RO	40
8	OB	19
9	B	ALL
10	B	19
11	B	ALL
12	LGB	ALL
13	BLG	ALL
14	UY	40

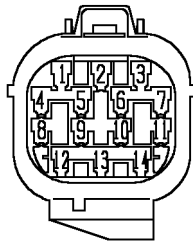

YPC10549

Colour: *GREY*
 Gender: *Female*

C1265

CONNECTOR DETAILS

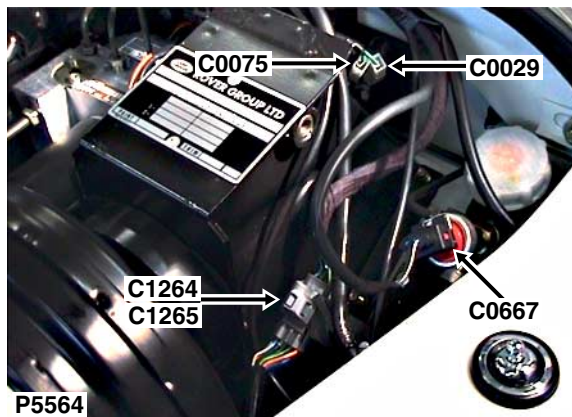

Description: *Wing harness to main harness*

Location: *Adjacent pedal box*

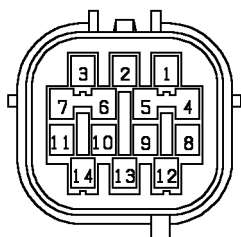

YPC10469

Colour: *GREY*

Gender: *Male*

Cav	Col	Cct
1	US	ALL
2	UK	ALL
3	B	ALL
4	GR	ALL
5	RB	ALL
6	PB	ALL
7	RO	37
7	UO	42
8	OB	37
9	B	37
10	B	37
11	B	37
12	LGB	ALL
13	BLG	ALL
14	UY	37

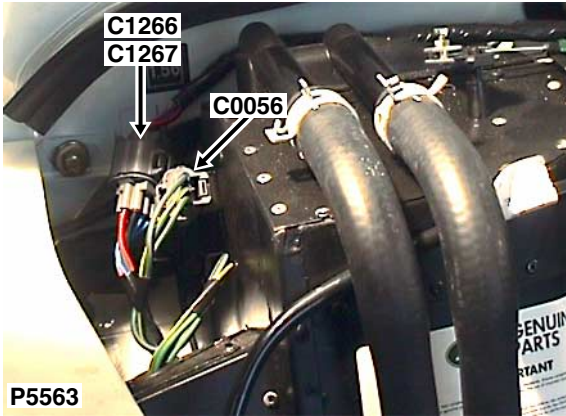

Cav	Col	Cct
1	UO	ALL
2	UB	ALL
3	B	ALL
4	GW	ALL
5	RO	ALL
6	PB	ALL
7	RO	40
8	UY	40
9	NU	6
10	NG	22

Description: *Main harness to wing harness*

Location: *Adjacent heater assembly*

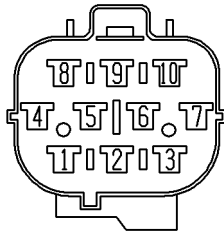

YPC10633

Colour: *GREY*

Gender: *Female*

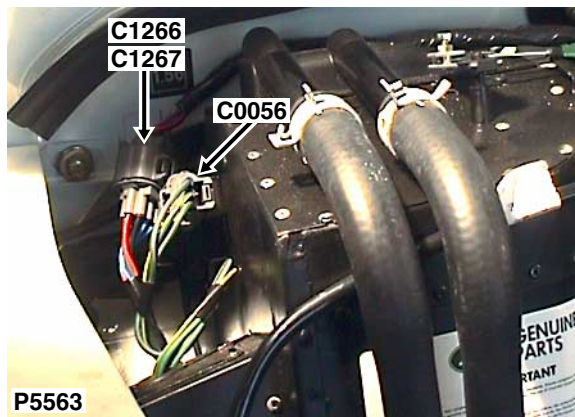

Description: *Wing harness to main harness*

Location: *Adjacent heater assembly*

Cav	Col	Cct
1	UO	ALL
2	UB	ALL
3	B	ALL
4	GW	ALL
5	RO	1
5	RB	42
6	PB	1
7	RO	37
7	UO	42
8	UY	37
9	NW	37
10	NG	37

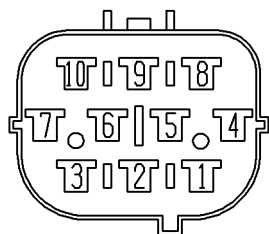

YPC10468

Colour: *GREY*

Gender: *Male*

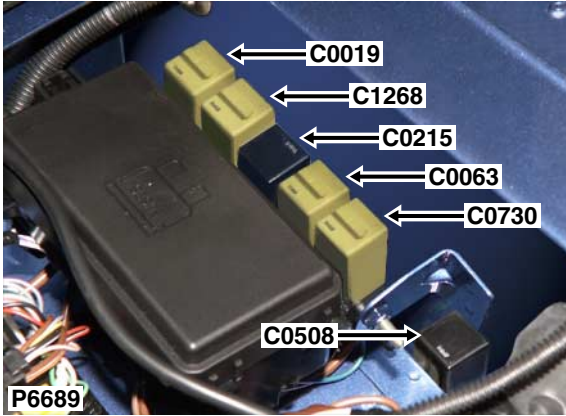

Cav	Col	Cct
30	NS	25
85	WG	25
86	WK	25
87	BG	25

Description: *Relay - Compressor clutch - Air conditioning (A/C)*
 Location: *Beneath RH seat*

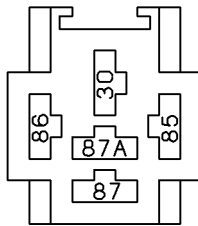

AFU3271

Colour: *YELLOW*
 Gender: *Female*

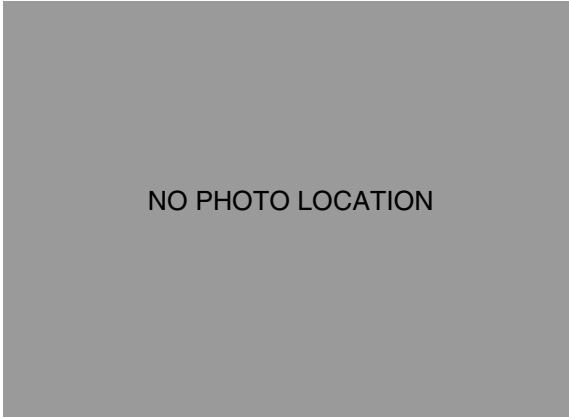

Description: *Unit - Air conditioning (a/c)*

Location: *Behind LH side of fascia*

Cav	Col	Cct
1	WB	ALL
2	UG	ALL
3	B	ALL
4	RW	ALL
5	UY	ALL
7	K	ALL
8	GW	ALL
9	UB	ALL
11	WG	ALL
12	U	ALL
14	UW	ALL

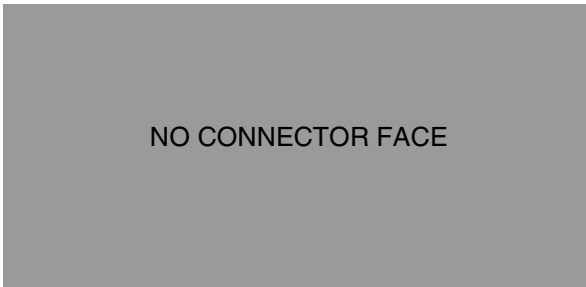

Colour: *NATURAL*

Gender: *Female*

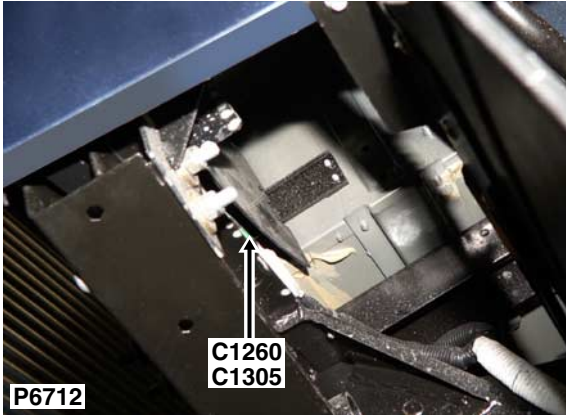

Cav	Col	Cct
1	GR	16
2	RB	16
3	GW	16
4	RO	16
5	GP	16
6	P	16
7	GN	16
8	RY	16
9	B	ALL

Description: *Trailer pick-up*
 Location: *Below RH rear wheelarch*

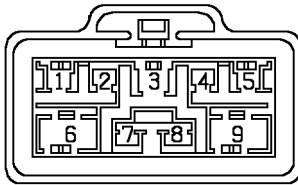

YPC114850

Colour: *GREY*
 Gender: *Female*

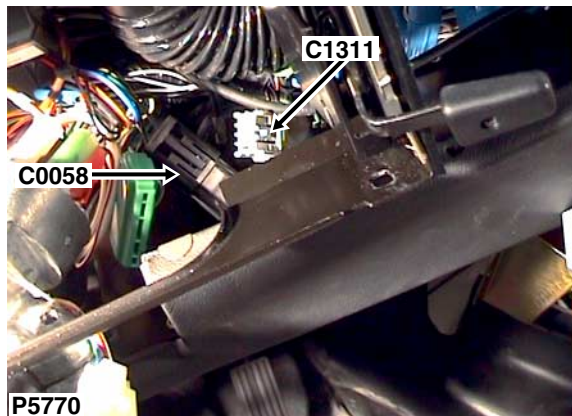

Cav	Col	Cct
1	WG	2
2	B	2
3	YK	ALL
4	BK	2
5	WP	2

Description: *ECU - Speed (Gulf states only)*

Location: *Behind instrument pack*

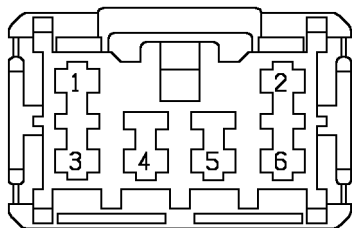

YPC10634

Colour: *LIGHT GREY*

Gender: *Female*

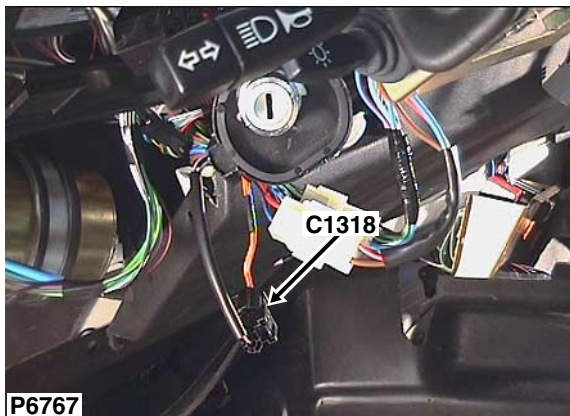
**P6767**Description: *Coil - Transponder*Location: *Behind steering column cowl LH side*

Cav	Col	Cct
1	OG	20
2	OP	20

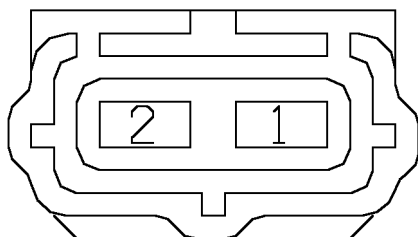

YPC10069

Colour: *BLACK*Gender: *Female*

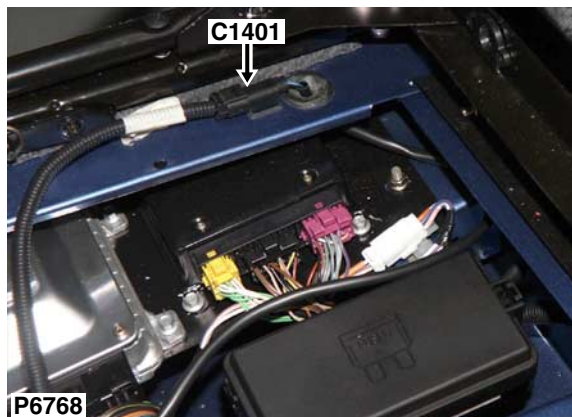

Cav	Col	Cct
1	US	26
2	B	26

Description: *Heated seat - LH*

Location: *Beneath LH seat*

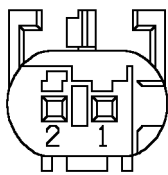

YPC110710

Colour: *BLACK*

Gender: *Male*

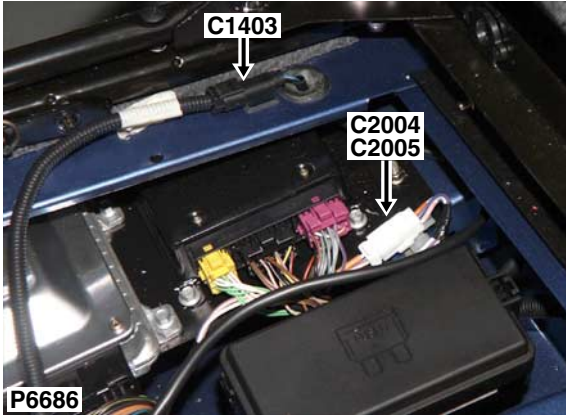

Cav	Col	Cct
1	UK	26
2	B	26

Description: *Heated seat - RH*
 Location: *Beneath RH seat*

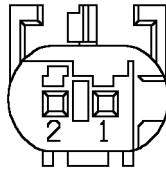

YPC110710

Colour: *BLACK*
 Gender: *Male*

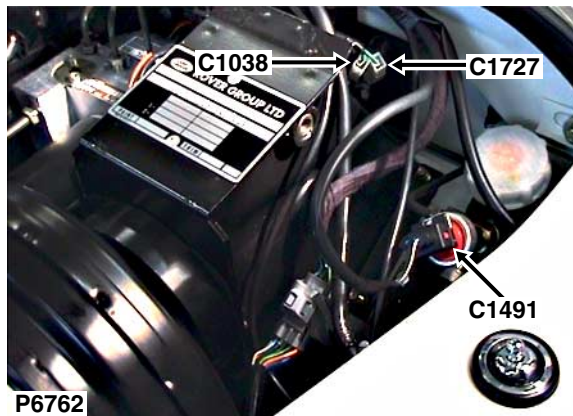

Cav	Col	Cct
1	BW	5
2	B	5

Description: *Switch - Clutch pedal*
 Location: *Adjacent pedal box*

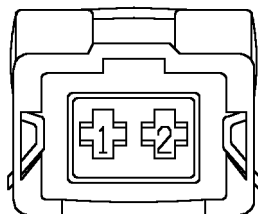

YPC107790

Colour: *BLACK*
 Gender: *Female*

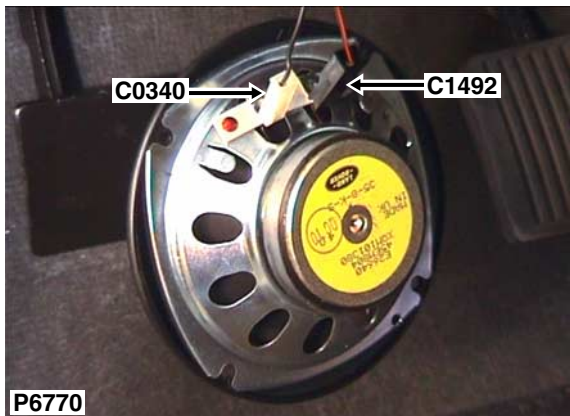

Cav	Col	Cct
1	BN	ALL

P6770

Description: *Speakers - Front*
 Location: *Under LH side of fascia*

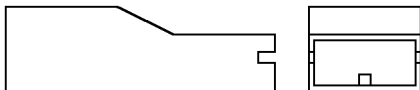

AAU1010

Colour: *BLACK*
 Gender: *Female*

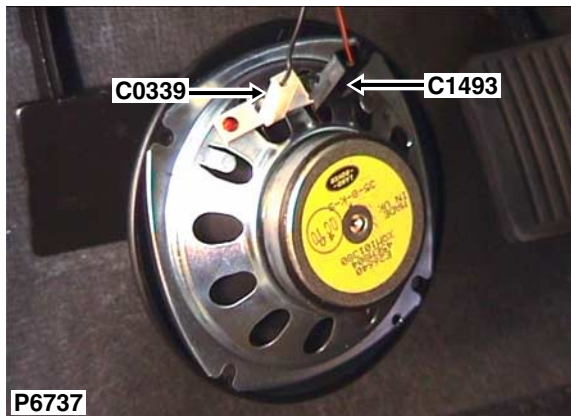

Cav	Col	Cct
1	BR	2

Description: *Speakers - Front*

Location: *Under RH side of fascia*

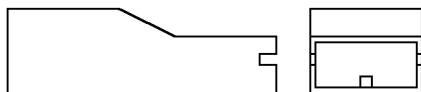

AAU1010

Colour: *BLACK*

Gender: *Female*

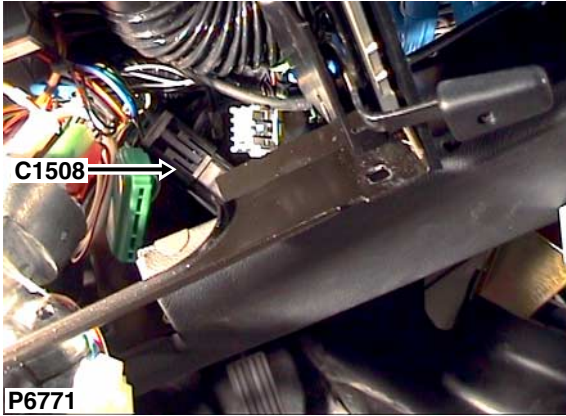

Cav	Col	Cct
1	GS	2
2	GY	2
3	B	2

Description: *Switch - Blower motor*
Location: *Behind instrument pack*

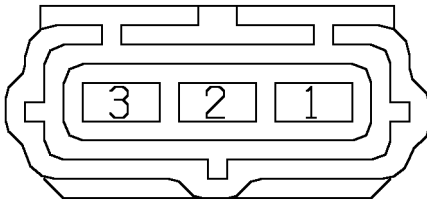

YPC10067

Colour: *BLACK*
Gender: *Female*

C1510

CONNECTOR DETAILS



Description: *Main harness to link harness*

Location: *Behind RH side of fascia*

Cav	Col	Cct
1	B	2
2	NLG	2
3	ULG	2
4	WG	2
5	RLG	2

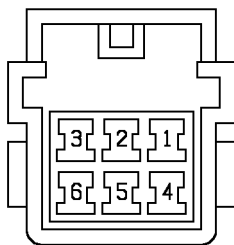

YPC10018

Colour: *NATURAL*

Gender: *Male*

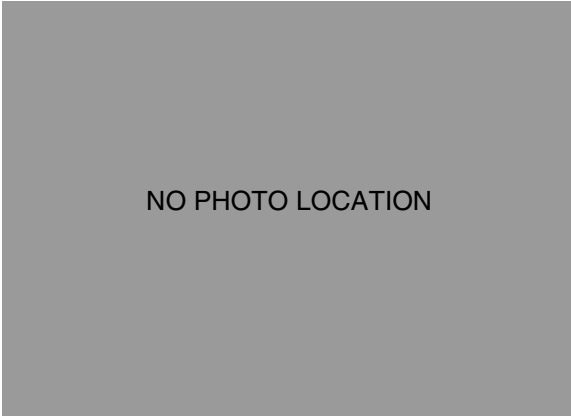

Cav	Col	Cct
1	B	ALL
2	NLG	ALL
3	ULG	ALL
4	WG	ALL
5	RLG	ALL

Description: *Link harness to main harness - LHD*

Location: *Behind RH side of fascia*

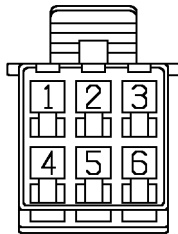

YPC10038

Colour: *NATURAL*

Gender: *Female*

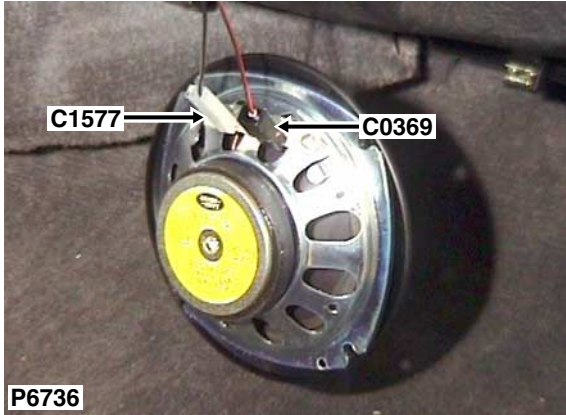

Cav	Col	Cct
1	BK	3

Description: *Speakers - Front*

Location: *Under RH side of fascia*

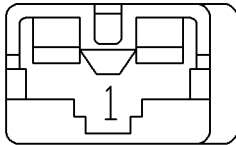

AFU4521

Colour: *NATURAL*

Gender: *Female*

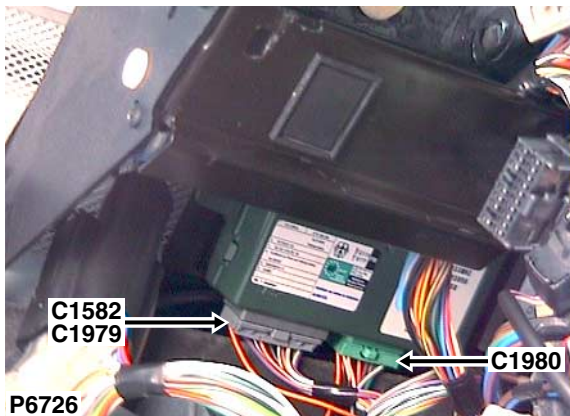

Cav	Col	Cct
1	OS	20

Description: *Aerial*

Location: *Behind instrument pack*

NO CONNECTOR FACE

Colour:

Gender:

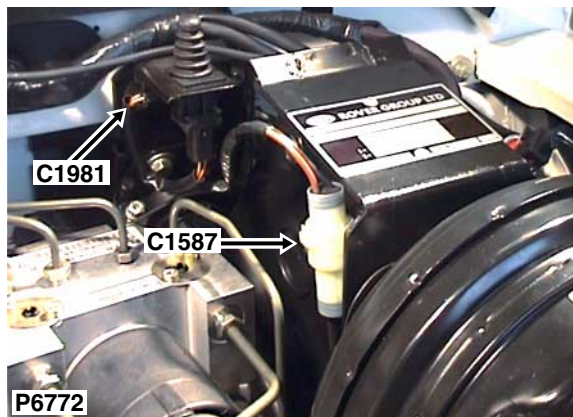

Cav	Col	Cct
1	NR	5
2	B	5

Description: *Pump - Return - ABS*

Location: *Adjacent pedal box*

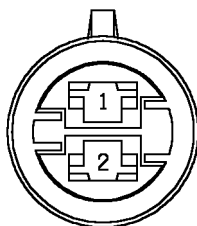

AFU3727

Colour: *NATURAL*

Gender: *Female*



Cav	Col	Cct
B	WP	5
C	RG	5
D	BY	5
F	WG	5
G	BY	5
J	WP	5
K	WS	5

P6774

Description: *Sensor - Position - Accelerator pedal*
 Location: *Under RH side of fascia*

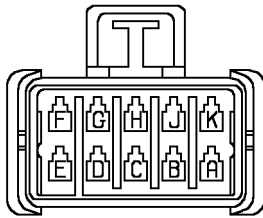

YPC111870

Colour: *BLACK*
 Gender: *Female*

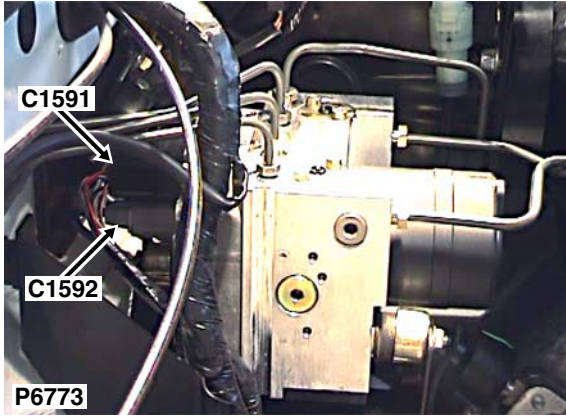

Description: *Modulator - ABS*

Location: *Behind ABS modulator*

Cav	Col	Cct
1	SW	5
2	SR	5
4	SK	5
5	SP	5
8	B	5
9	RB	5
10	SG	5
11	SU	5
12	SN	5
13	SY	5

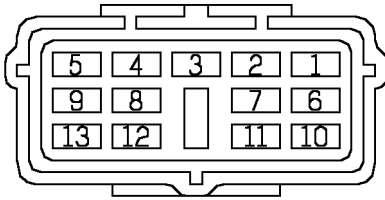

YPC10062

Colour: *BLACK*

Gender: *Female*

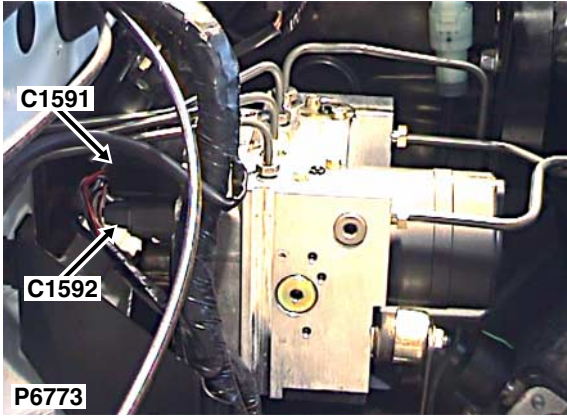

Cav	Col	Cct
1	B	5

Description: *Modulator - ABS*

Location: *Behind ABS modulator*

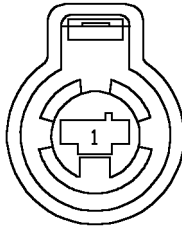

YPC109840

Colour: *LIGHT GREY*

Gender: *Female*

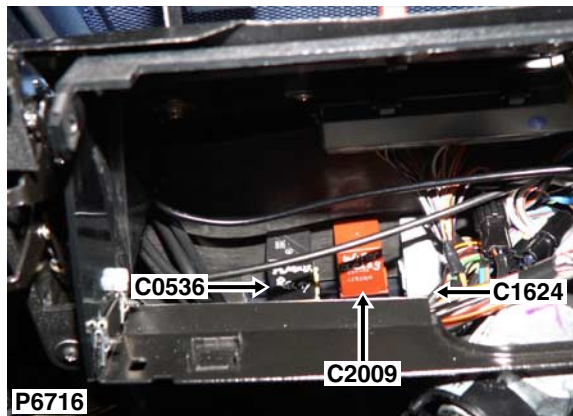

Cav	Col	Cct
2	B	26
4	WG	26
5	KO	26
6	WN	26
8	PY	26

Description: *Heated screen - Front*

Location: *Behind LH side of fascia*

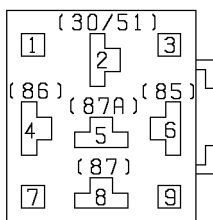

AFU4177

Colour: *BLACK*

Gender: *Female*

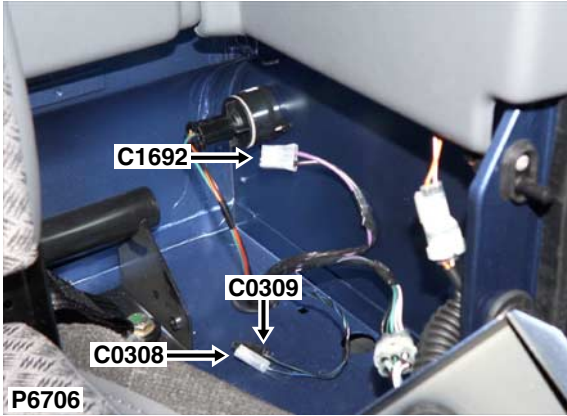

Cav	Col	Cct
1	B	ALL
2	P	ALL

Description: *Socket - Accessory*

Location: *Behind RH rear trim panel*

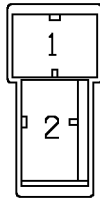

ADU9448

Colour: *NATURAL*

Gender: *Female*

C1724

CONNECTOR DETAILS

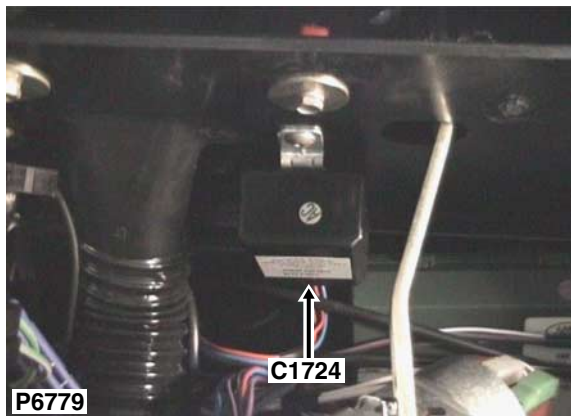

Cav	Col	Cct
1	B	2
2	UP	2
3	RY	2
4	BS	2

Description: *ECU - Lamp - Fog guard - Rear*

Location: *Behind instrument pack*

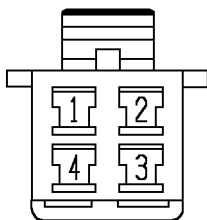

YPC10002

Colour: *NATURAL*

Gender: *Female*

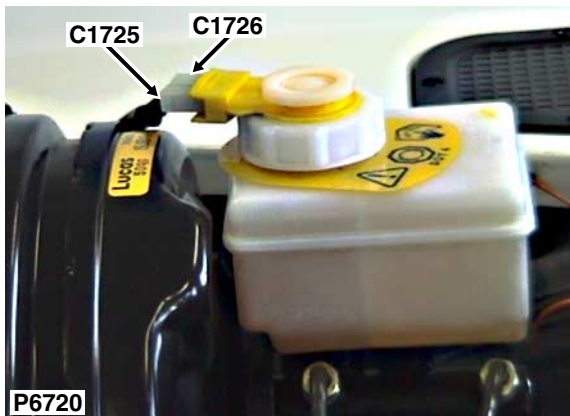

Cav	Col	Cct
1	BW	2

Description: *Switch - Brake fluid level*

Location: *Adjacent pedal box*

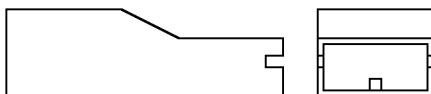

ADU8339

Colour: *NATURAL*

Gender: *Female*

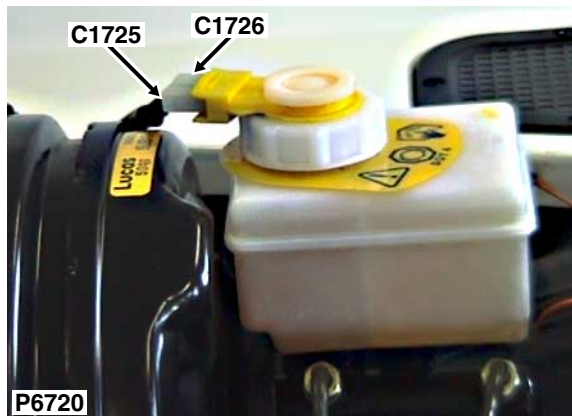

Cav	Col	Cct
1	B	2

Description: *Switch - Brake fluid level*

Location: *Adjacent pedal box*

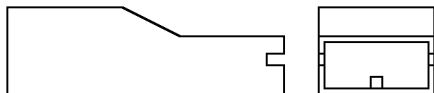

ADU8339

Colour: *NATURAL*

Gender: *Female*

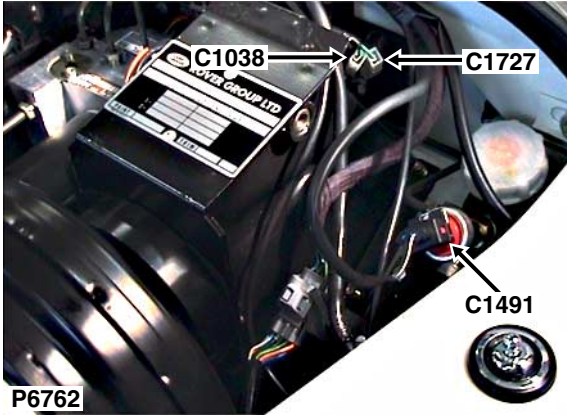

Cav	Col	Cct
1	GP	2

Description: *Switch - Brake pedal*
Location: *Adjacent pedal box*

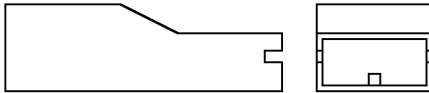

ADU8339

Colour: *NATURAL*
Gender: *Female*

Cav	Col	Cct
1	WO	2

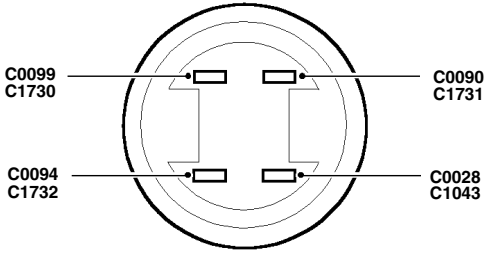

Description: *Switch - Ignition*

Location: *Behind instrument pack*

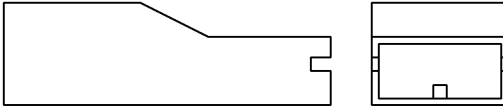

YPC115690

Colour: *GREEN*

Gender: *Female*

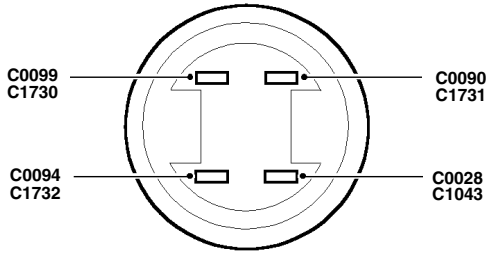

Cav	Col	Cct
1	WR	2

Description: *Switch - Ignition*
 Location: *Behind instrument pack*



YPC10245

Colour: *RED*
 Gender: *Female*

Cav	Col	Cct
1	W	ALL

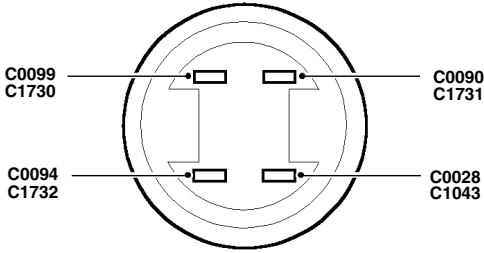

Description: *Switch - Ignition*

Location: *Behind instrument pack*

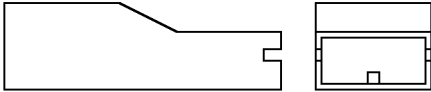

ADU8339

Colour: *NATURAL*

Gender: *Female*

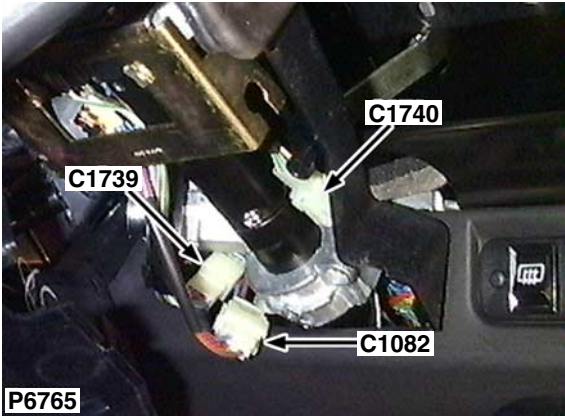

Cav	Col	Cct
1	U	2
2	GW	2
3	LGN	2
4	GR	2
5	UW	2
6	UR	2
7	NP	2
8	PB	2

Description: *Switch - Horn / Dim dip*
 Location: *Behind steering column cowl LH side*

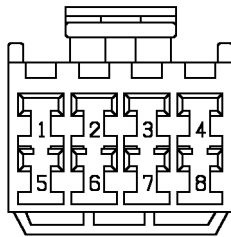

AFU3574

Colour: *NATURAL*
 Gender: *Female*

C1740

CONNECTOR DETAILS

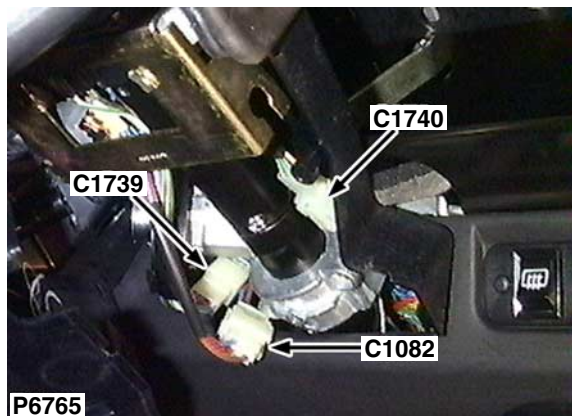

Cav	Col	Cct
1	ULG	2
2	LGB	2
3	WG	2
4	YLG	2
5	RLG	2
6	WG	2

Description: *Switch - Wash / wipe - Windscreen*

Location: *Behind steering column cowl LH side*

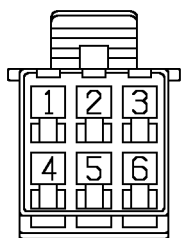

YPC10038

Colour: *NATURAL*

Gender: *Female*

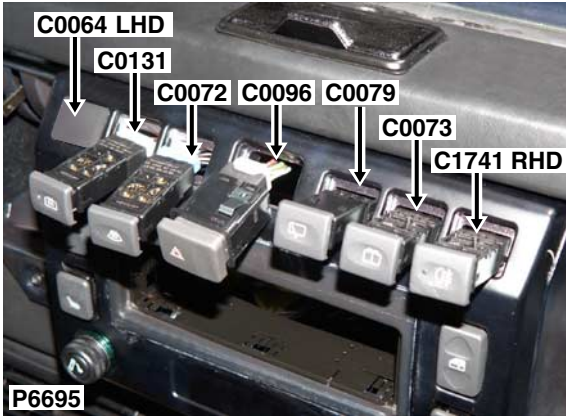

Cav	Col	Cct
1	BS	3
2	RO	3
4	B	3
5	RY	3

Description: *Switch - Fog guard lamp - Rear*
 Location: *Behind centre of fascia*

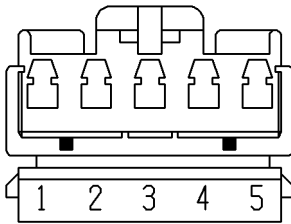

YPC10523

Colour: *BLACK*
 Gender: *Female*

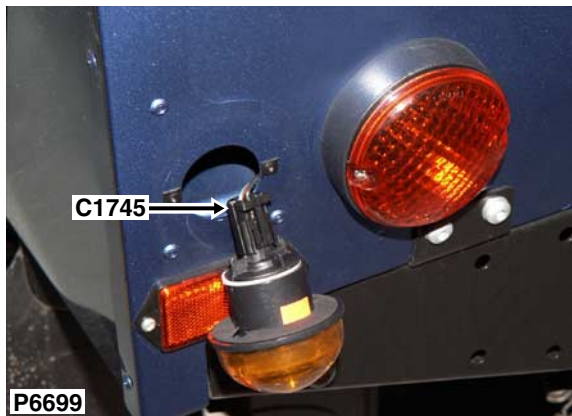

Cav	Col	Cct
1	B	16
2	GR	16

Description: *Lamp - Direction indicator / hazard warning - Rear - LH*
 Location: *LH rear of vehicle*

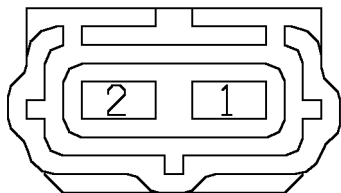

YPC10070

Colour: *BLACK*
 Gender: *Female*

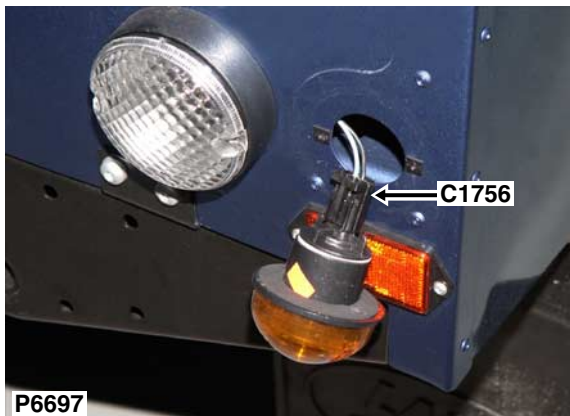

Cav	Col	Cct
1	B	ALL
2	GW	16

Description: *Lamp - Direction indicator / hazard warning - Rear - RH*
 Location: *RH rear of vehicle*

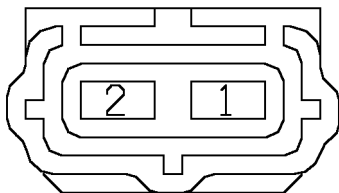

YPC10070

Colour: *BLACK*
 Gender: *Female*

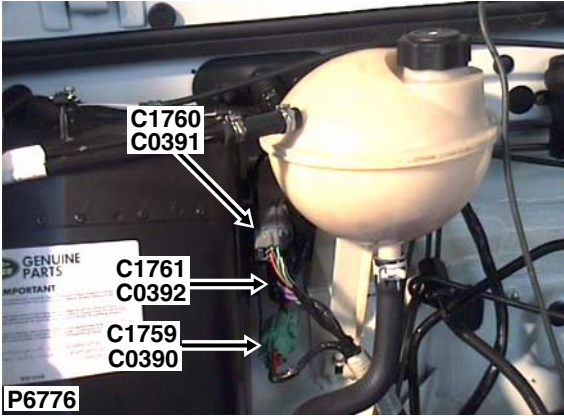

Cav	Col	Cct
1	RO	13
2	RB	13
3	RY	13
4	GR	13
5	GW	13
6	GP	13
7	S	13
8	W	13
9	GN	13

Description: *Chassis harness to main harness*

Location: *Rear of engine compartment*

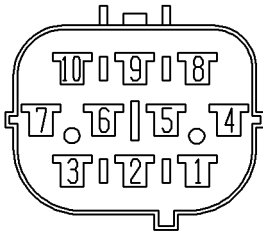

YPC10468

Colour: *GREY*

Gender: *Male*

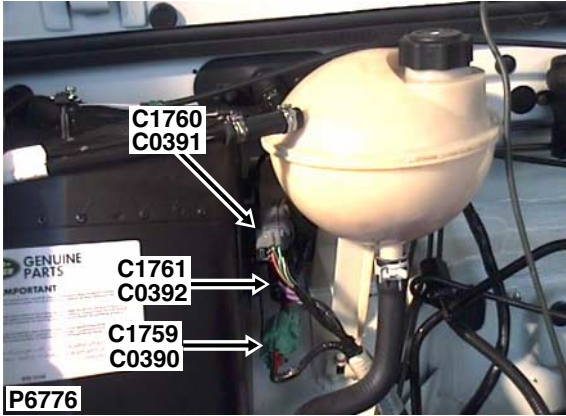

Cav	Col	Cct
1	SB	ALL
2	WB	13
3	WG	ALL
4	BG	13
5	GB	ALL
6	OG	14

Description: *Chassis harness to main harness*

Location: *Rear of engine compartment*

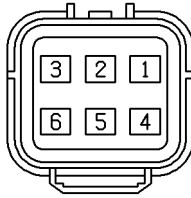

YPC 106620

Colour: *GREY*

Gender: *Male*

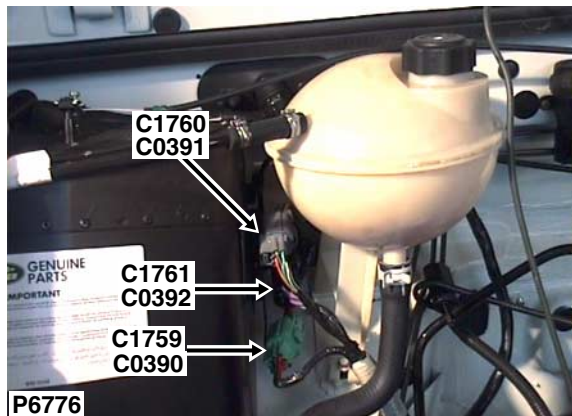

Cav	Col	Cct
1	P	13
4	WP	14

Description: *Chassis harness to main harness*

Location: *Rear of engine compartment*

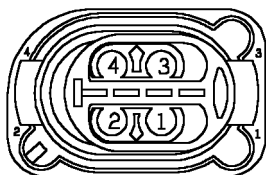

YPC110200

Colour: *BLACK*

Gender: *Female*

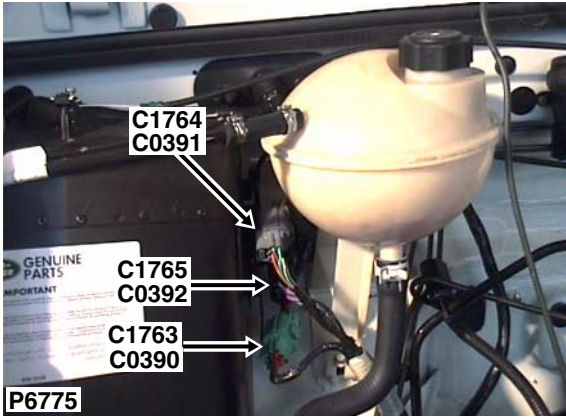

Cav	Col	Cct
1	RO	16
2	RB	16
3	RY	16
4	GR	16
5	GW	16
6	GP	16
7	S	16
8	W	16
9	GN	16

Description: *Chassis harness to main harness*

Location: *Rear of engine compartment*

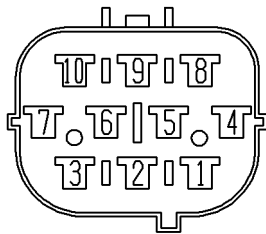

YPC10468

Colour: *GREY*

Gender: *Male*

C1764

CONNECTOR DETAILS

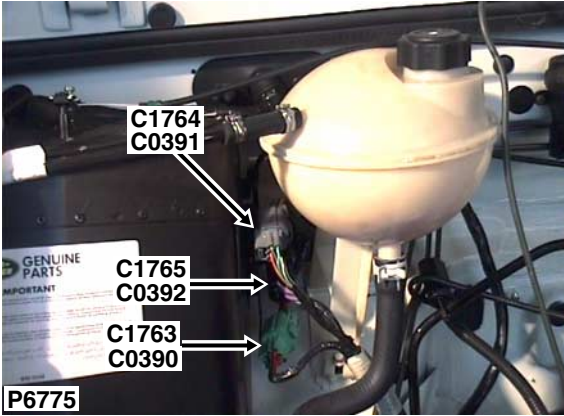

Cav	Col	Cct
1	SB	ALL
3	WG	17
5	GB	ALL
6	OG	17

Description: *Chassis harness to main harness*

Location: *Rear of engine compartment*

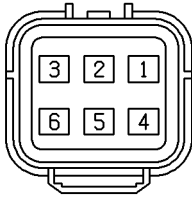

YPC106620

Colour: *GREY*

Gender: *Male*

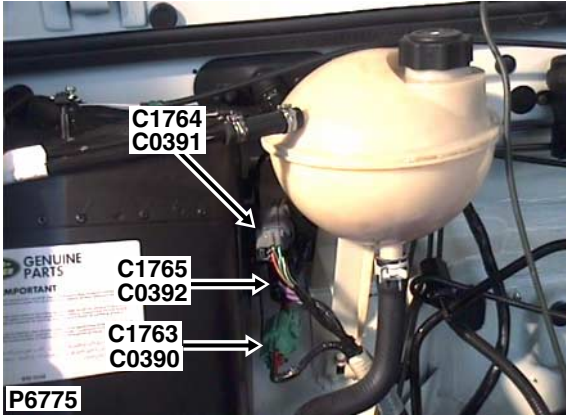

Cav	Col	Cct
1	P	16
4	WP	17

Description: *Chassis harness to main harness*
 Location: *Rear of engine compartment*

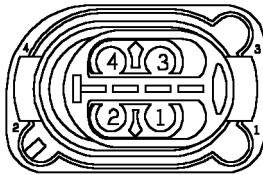

YPC110200

Colour: *BLACK*
 Gender: *Female*

C1978

CONNECTOR DETAILS

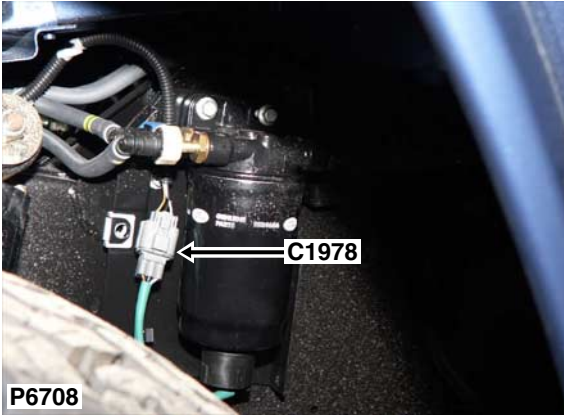

Cav	Col	Cct
1	OG	14
2	B	14
3	WG	14

Description: *Sensor - Water filter*

Location: *Below RH rear wheelarch*

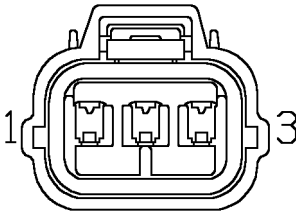

YPC10181

Colour: *LIGHT GREY*

Gender: *Female*

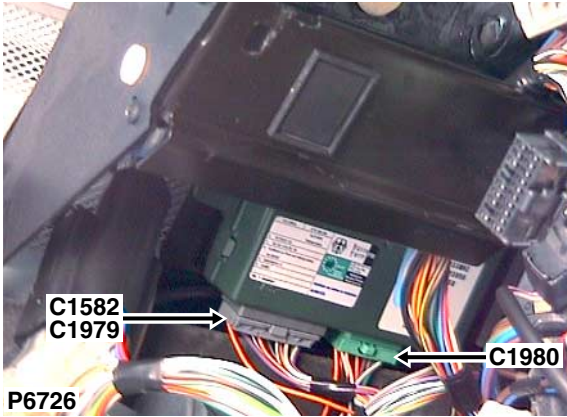

Description: *ECU - Alarm*
 Location: *Behind instrument pack*

Cav	Col	Cct
1	PW	20
3	WB	20
5	SW	20
7	YK	20
9	OU	20
10	WG	20
14	LGS	ALL
16	PU	20
17	OLG	20
20	BN	20
25	PN	20
26	OS	20

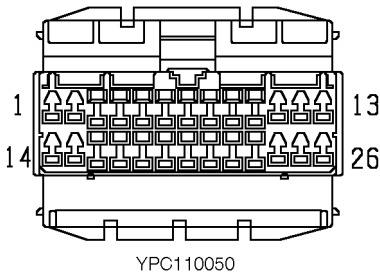

Colour: *GREY*
 Gender: *Female*

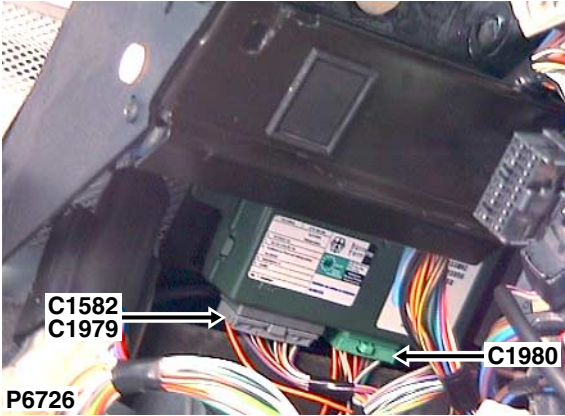

Description: *ECU - Alarm*

Location: *Behind instrument pack*

Cav	Col	Cct
1	GW	20
2	O	20
3	K	20
4	K	20
5	OW	20
6	GR	20
7	OG	20
8	PN	20
9	O	20
10	BO	20
11	B	20
12	OP	20

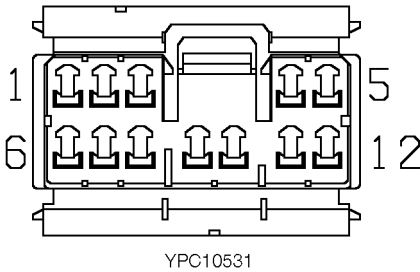

Colour: *GREEN*
 Gender: *Female*

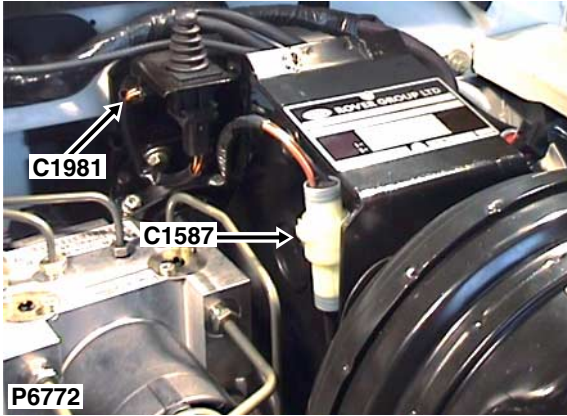

Cav	Col	Cct
1	B	20
2	OU	20

Description: *Switch - Bonnet*
 Location: *Adjacent pedal box*

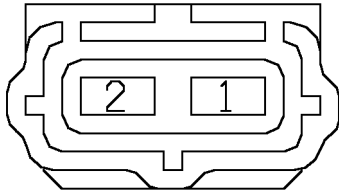

YPC10070

Colour: *BLACK*
 Gender: *Female*

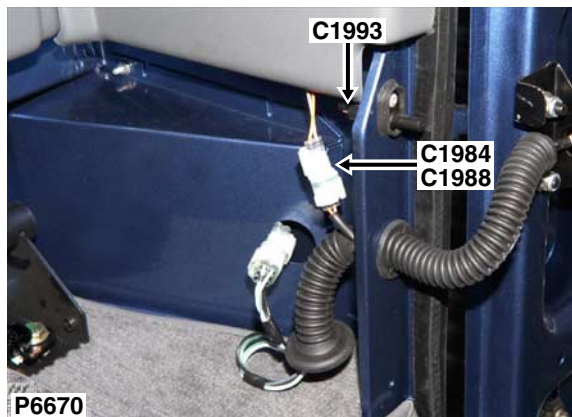

Cav	Col	Cct
1	K	24
2	O	24

Description: *Lamp - Interior - Rear*

Location: *Behind RH rear trim panel*

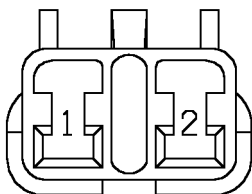

AFU3635

Colour: *NATURAL*

Gender: *Female*

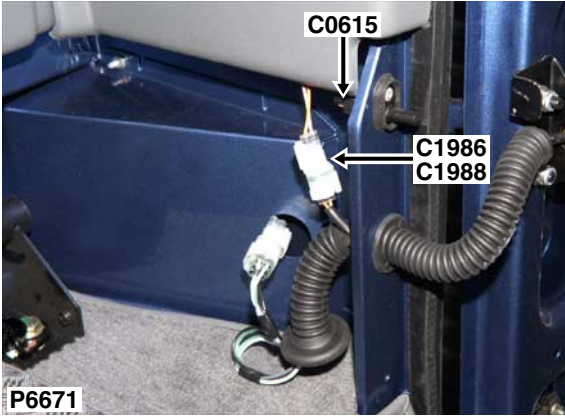

Cav	Col	Cct
1	K	24
2	O	24

Description: *Lamp - Interior - Rear*

Location: *Behind RH rear trim panel*

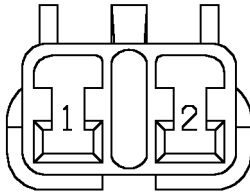

AFU3635

Colour: *NATURAL*

Gender: *Female*

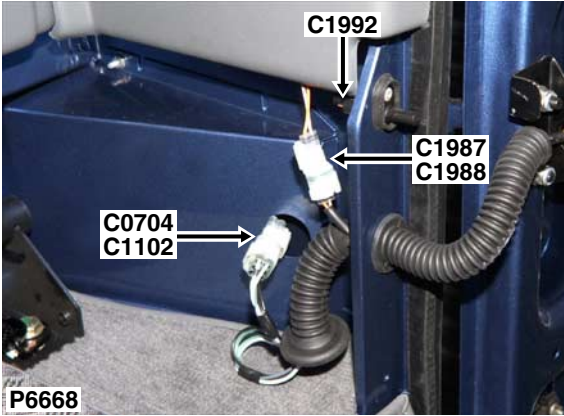

Cav	Col	Cct
1	K	44
2	O	44

Description: *Lamp - Interior - Rear*

Location: *Behind RH rear trim panel*

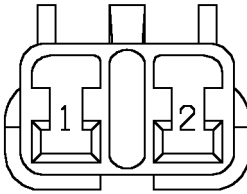

AFU3635

Colour: *NATURAL*

Gender: *Female*

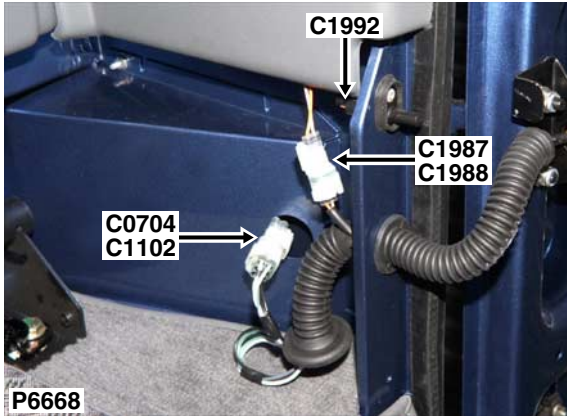

Cav	Col	Cct
1	K	19
2	O	19

Description: *Lamp - Interior - Rear*

Location: *Behind RH rear trim panel*

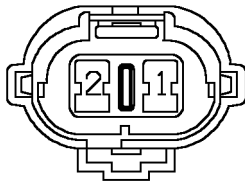

AFU3584

Colour: *NATURAL*

Gender: *Male*

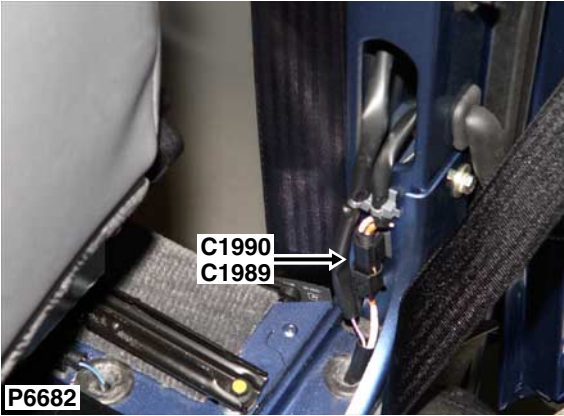

Cav	Col	Cct
1	O	19
2	K	19

Description: *Rear door harness to body harness*

Location: *'C' post*

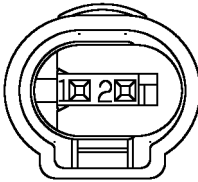

YPC116820

Colour: *BLACK*

Gender: *Female*

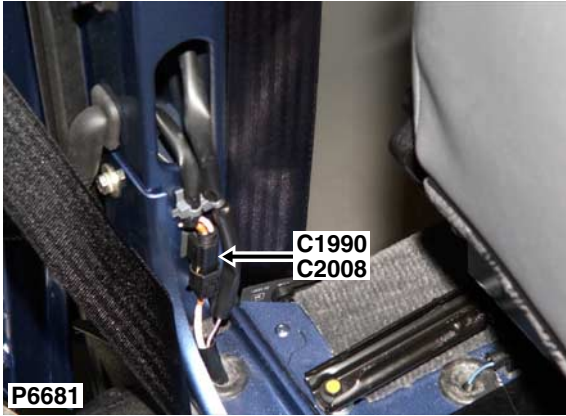

Cav	Col	Cct
1	O	ALL
2	K	ALL

Description: *Rear door harness to body harness*
 Location: *'C' post*

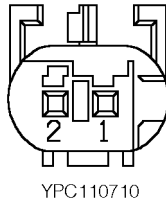

Colour: *BLACK*
 Gender: *Male*

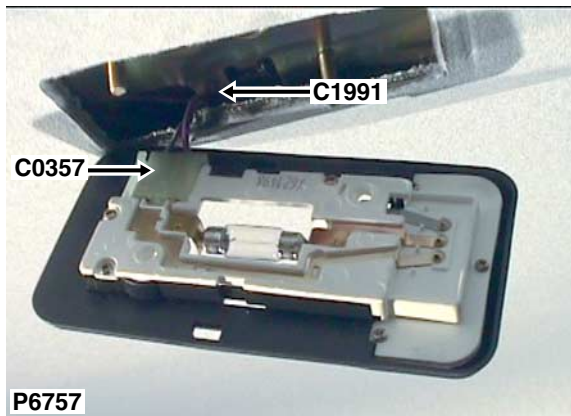

Cav	Col	Cct
1	B	24

Description: *Earth*

Location: *Rear of headlining*

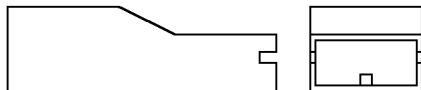

AAU1010

Colour: *BLACK*

Gender: *Female*

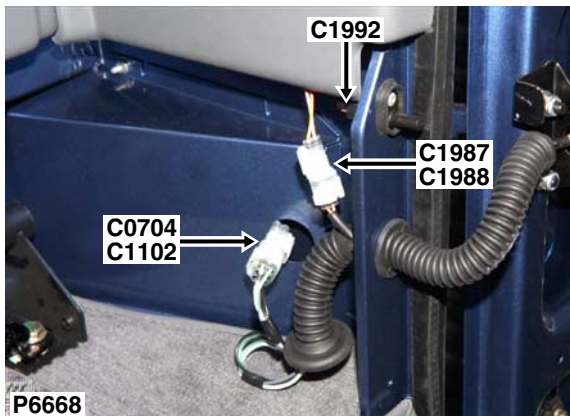

Cav	Col	Cct
1	PU	44

Description: *Switch - Boot / tail door*

Location: *Behind RH rear trim panel*

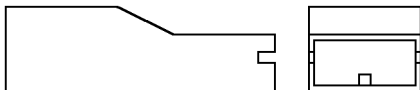

AAU1010

Colour: *BLACK*

Gender: *Female*

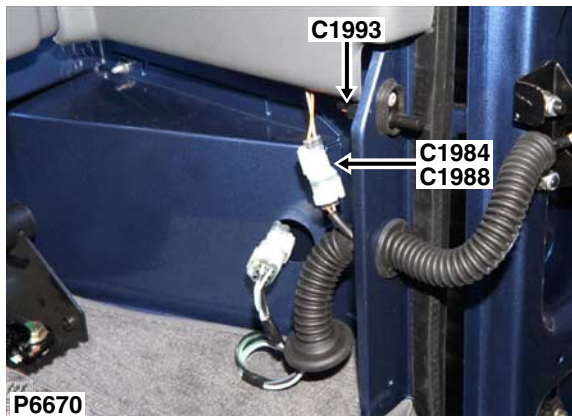

Cav	Col	Cct
1	PU	35

Description: *Switch - Boot / tail door*
 Location: *Behind RH rear trim panel*

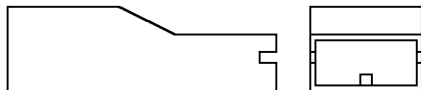

AAU1010

Colour: *BLACK*
 Gender: *Female*

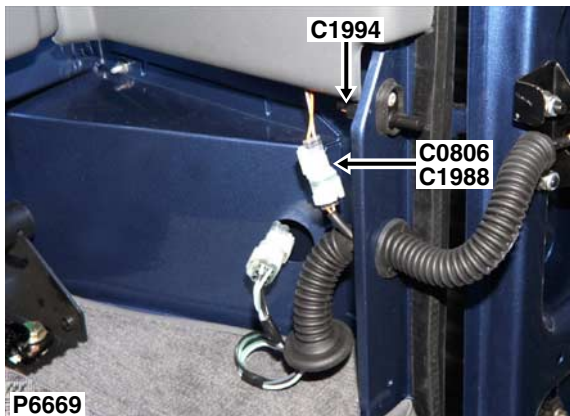

Cav	Col	Cct
1	PU	47

Description: *Switch - Boot / tail door*

Location: *Behind RH rear trim panel*

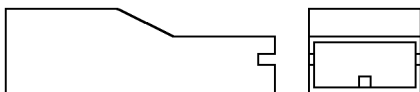

AAU1010

Colour: *BLACK*

Gender: *Female*

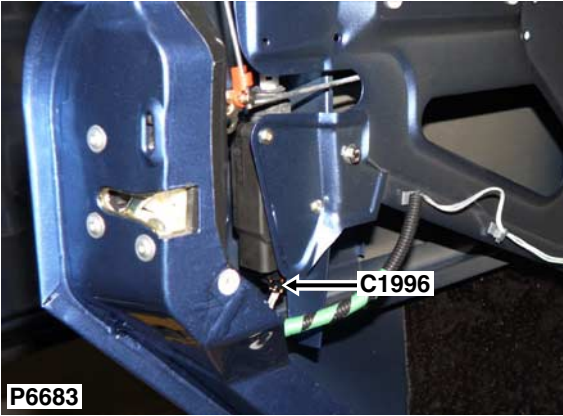

Cav	Col	Cct
1	O	ALL
2	K	ALL

Description: *Motor - Door lock - Rear*

Location: *Behind rear door trim panel*

NO CONNECTOR FACE

Colour: *BLACK*

Gender: *Female*

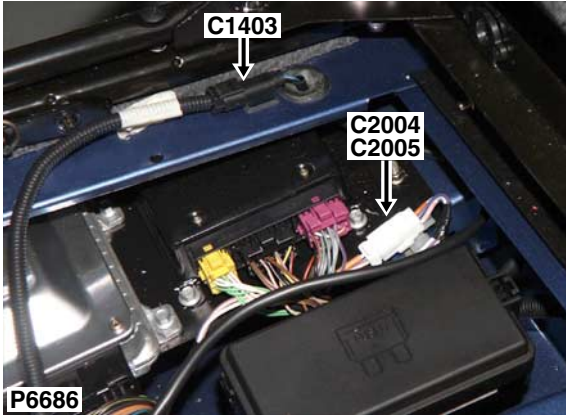

Cav	Col	Cct
1	K	ALL
2	PU	ALL
2	PW	30
3	O	ALL

Description: *Main harness to door harness*
 Location: *Beneath RH seat*

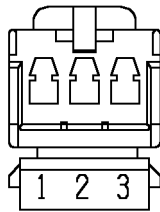

YPC10227

Colour: *WHITE*
 Gender: *Female*

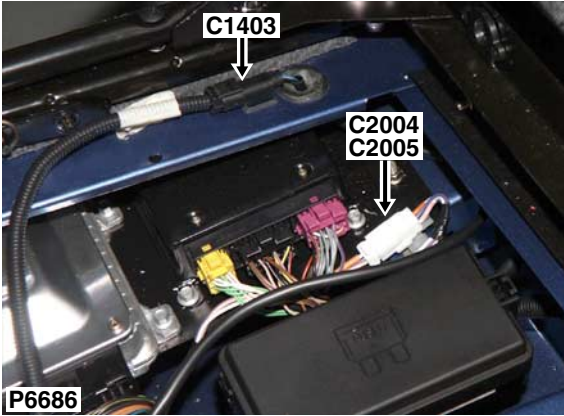

Description: *Door harness to main harness*
Location: *Beneath RH seat*

Cav	Col	Cct
1	K	19
2	PU	ALL
3	O	19

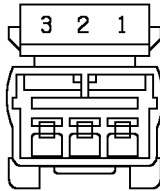

YPC10272

Colour: *WHITE*
Gender: *Male*



Cav	Col	Cct
1	B	26

Description: *Heated screen - Front*
 Location: *Behind RH side of fascia*

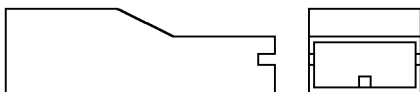

AAU1010

Colour: *BLACK*
 Gender: *Female*

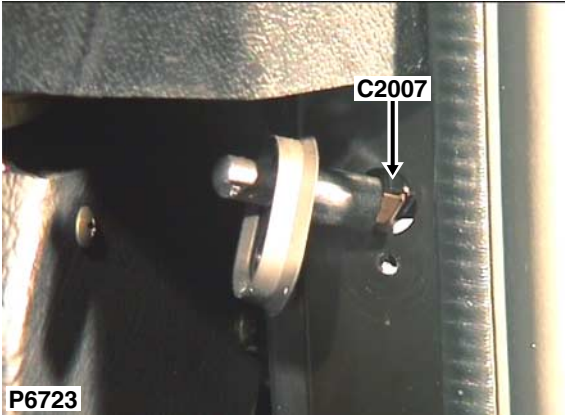

Cav	Col	Cct
1	SW	21

Description: *Switch - Door - RH*
Location: *RH 'A' post*

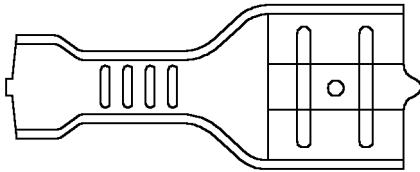

AFU3262

Colour: *BRASS, TIN-PLATED*
Gender: *Female*

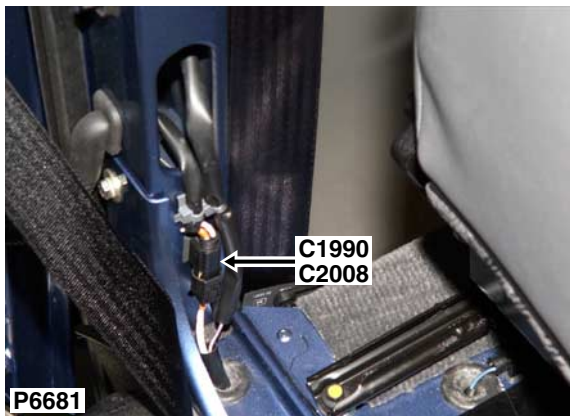

Cav	Col	Cct
1	O	19
2	K	19

Description: *Door harness to main harness*

Location: *'C' post*

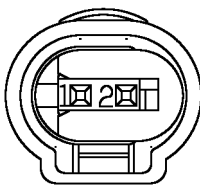

YPC116820

Colour: *BLACK*

Gender: *Female*

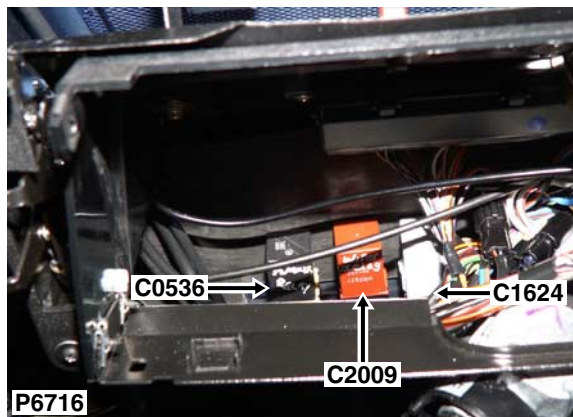

Cav	Col	Cct
1	WG	2
2	YLG	2
4	B	2
5	NLG	2
6	LGB	2
8	WG	2

Description: *ECU - Delay - Windscreen wiper*

Location: *Behind LH side of fascia*

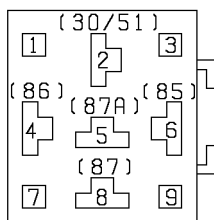

AFU4177

Colour: *BLACK*

Gender: *Female*

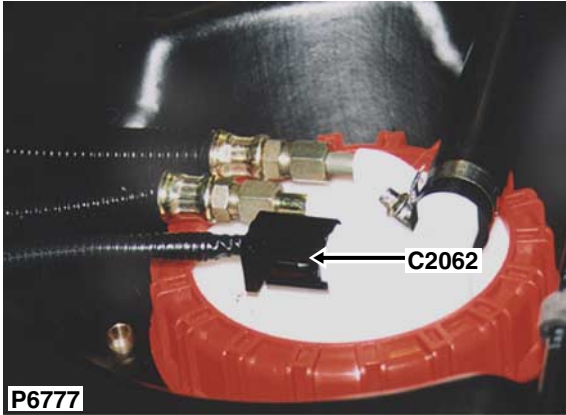

Cav	Col	Cct
1	GB	18
2	SB	18
3	B	18

Description: *Fuel tank*

Location: *Above fuel tank*

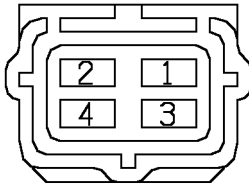

YPC10066

Colour: *BLACK*

Gender: *Female*

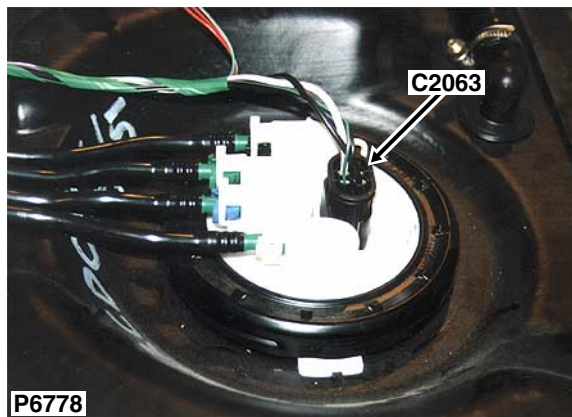

Cav	Col	Cct
1	WP	17
2	GB	17
3	SB	17
4	B	17

Description: *Fuel tank*

Location: *Above fuel tank*

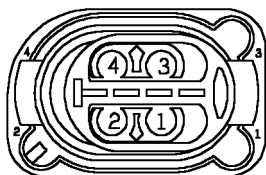

YPC110200

Colour: *BLACK*

Gender: *Female*

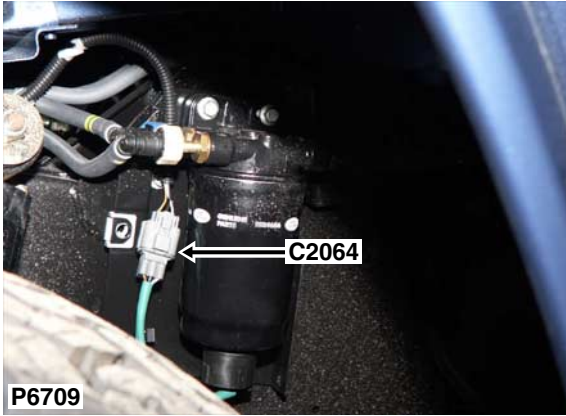

Cav	Col	Cct
1	OG	17
2	B	17
3	WG	17

Description: *Sensor - Water filter*
 Location: *Below RH rear wheelarch*

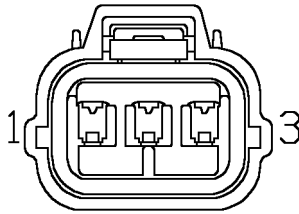

YPC10181

Colour: *LIGHT GREY*
 Gender: *Female*

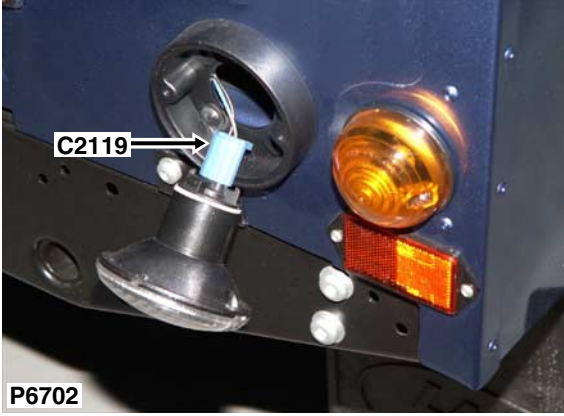

Cav	Col	Cct
1	B	ALL
2	S	ALL

P6702

Description: *Lamp - Reverse - RH*

Location: *RH rear of vehicle*

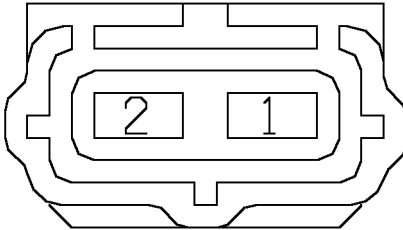

YPC10208

Colour: *BLUE*

Gender: *Female*

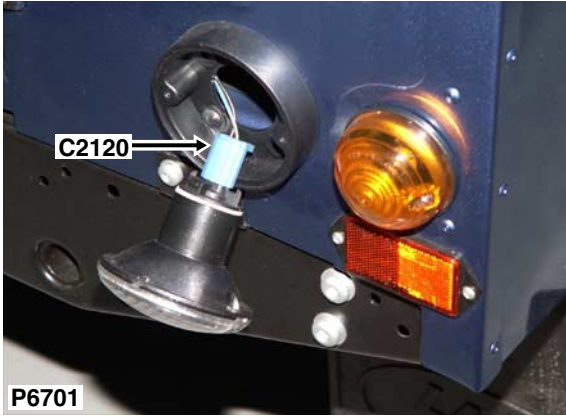

Cav	Col	Cct
1	B	ALL
2	S	16

Description: *Lamp - Reverse - RH - 130*
 Location: *RH rear of vehicle*

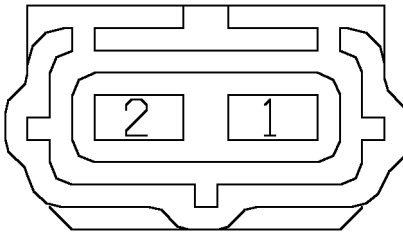

YPC10208

Colour: *BLUE*
 Gender: *Female*

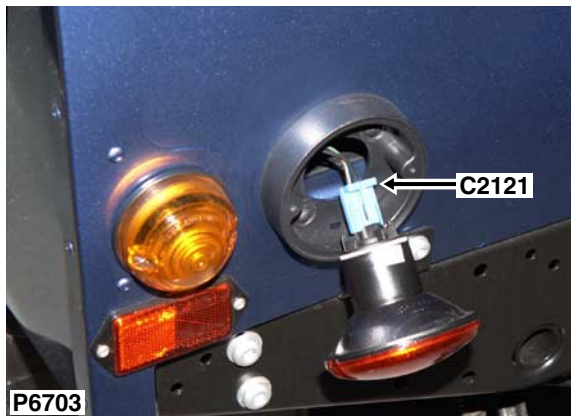

Cav	Col	Cct
1	B	16
2	W	16

Description: *Lamp - Reverse - LH - 130*

Location: *LH rear of vehicle*

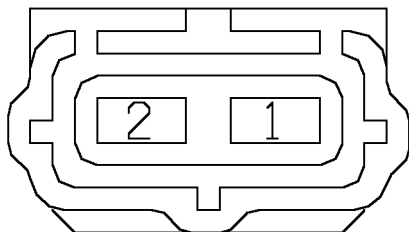

YPC10208

Colour: *BLUE*

Gender: *Female*

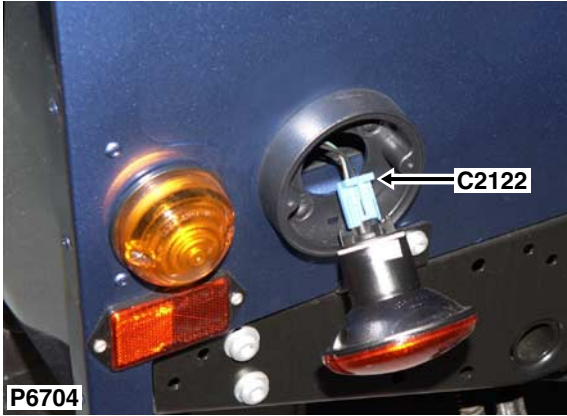

Cav	Col	Cct
1	B	ALL
2	W	ALL

Description: *Lamp - Reverse - LH*
Location: *LH rear of vehicle*

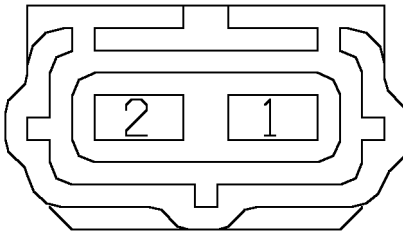

YPC10208

Colour: *BLUE*
Gender: *Female*