

EHX User Guide

Eclipse® 10.0 HX (EHX) Software User Guide

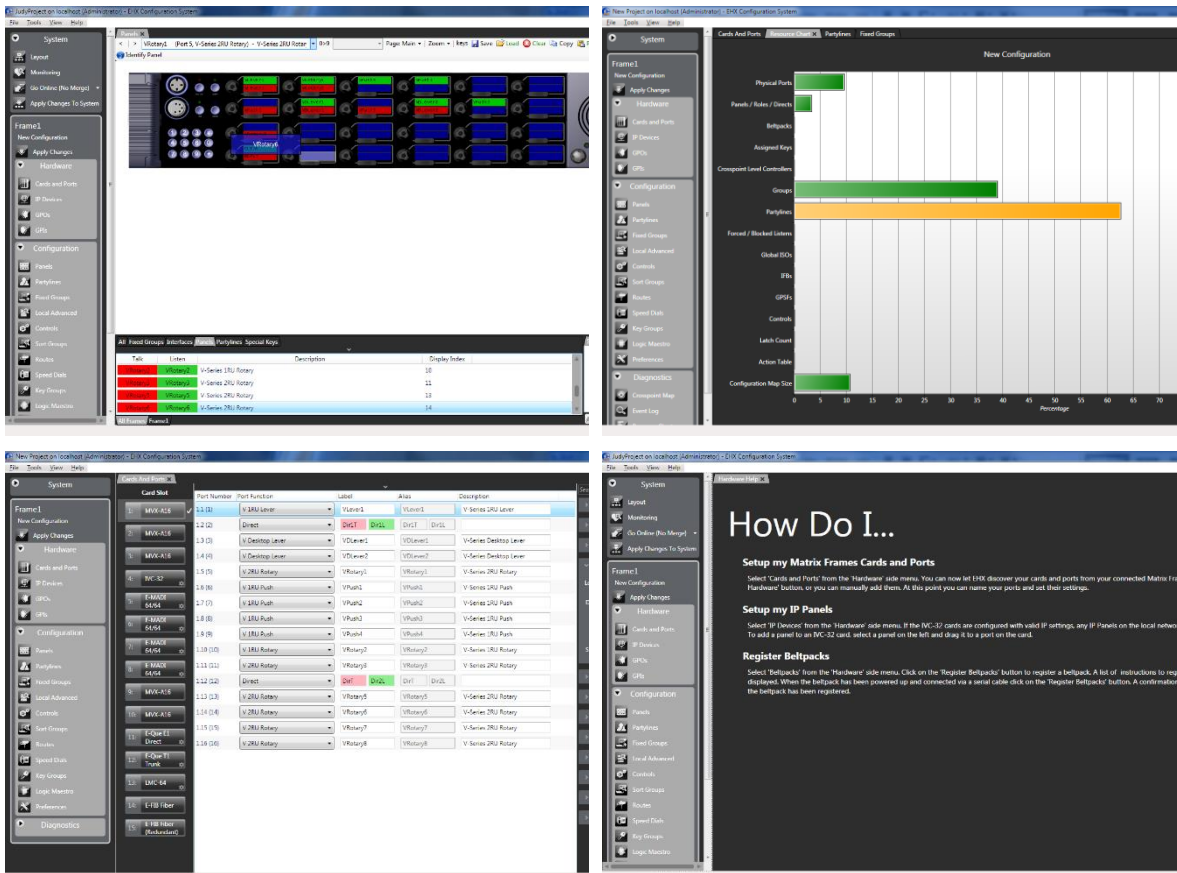

Part Number: 399G263 Revision A

Date: 27 July 2018

Document Reference

EHX User Guide

Part Number: 399G263 Revision: A

Legal Disclaimers

Copyright © 2018 HME Clear-Com Ltd.

All rights reserved.

Clear-Com, the Clear-Com logo, and Clear-Com Concert are trademarks or registered trademarks of HM Electronics, Inc.

The software described in this document is furnished under a license agreement and may be used only in accordance with the terms of the agreement.

The product described in this document is distributed under licenses restricting its use, copying, distribution, and decompilation / reverse engineering. No part of this document may be reproduced in any form by any means without prior written authorization of Clear-Com, an HME Company.

Clear-Com Offices are located in California, USA; Cambridge, UK; Dubai, UAE; Montreal, Canada; and Beijing, China. Specific addresses and contact information can be found on Clear-Com's corporate website:

www.clearcom.com

Clear-Com Contacts

Americas and Asia-Pacific Headquarters

California, United States

Tel: +1 510 337 6600

Email: CustomerServicesUS@clearcom.com

Europe, Middle East, and Africa Headquarters

Cambridge, United Kingdom

Tel: +44 1223 815000

Email: CustomerServicesEMEA@clearcom.com

China Office

Beijing Representative Office

Beijing, P.R. China

Tel: +8610 65811360/65815577

Table of contents

1	Introduction to EHX Configuration Software	16
1.1	<i>System components</i>	16
1.2	<i>Setting up an Eclipse HX matrix system</i>	18
1.3	<i>Further information</i>	19
2	Getting started with EHX	20
2.1	<i>System requirements</i>	20
2.2	<i>Installing EHX</i>	21
2.3	<i>Installing .NET Framework</i>	23
2.4	<i>Logging into EHX</i>	24
2.5	<i>Importing your projects and configurations into EHX.....</i>	28
3	Connecting a matrix	29
3.1	<i>Introduction</i>	29
3.2	<i>Matrix Ethernet operation.....</i>	32
3.3	<i>Selecting Ethernet or serial connection.....</i>	35
3.4	<i>Adding a new matrix</i>	47
4	Using the EHX menus	51
4.1	<i>Eclipse HX configuration software (EHX).....</i>	51
4.2	<i>Top menu</i>	53
4.3	<i>System menu.....</i>	54
4.4	<i>Hardware menu</i>	55
4.5	<i>Configuration menu.....</i>	56
4.6	<i>Diagnostics menu</i>	58
4.7	<i>System pane menus.....</i>	59
4.8	<i>Keyboard shortcuts</i>	60
5	Managing configurations and users	62
5.1	<i>Introduction</i>	62
5.2	<i>Creating a project file.....</i>	62
5.3	<i>Opening a project</i>	62
5.4	<i>Password protection override.....</i>	63
5.5	<i>Closing a project.....</i>	63
5.6	<i>Importing and exporting a project.....</i>	64
5.7	<i>Saving a project</i>	64
5.8	<i>Deleting a project</i>	65

- 5.9 *Importing/exporting configuration keysets*..... 65
- 5.10 *User management*..... 67
- 5.11 *Logging in and out of EHX* 72
- 5.12 *Exiting EHX* 73
- 5.13 *System Access Codes* 73
- 5.14 *The EHX screen after a project has been loaded* 75
- 5.15 *Configuration options*..... 76
- 6 *Configuring hardware*.....85**
 - 6.1 *Matrix hardware setup*..... 85
 - 6.2 *Matrix hardware* 86
 - 6.3 *Selecting card slots*..... 87
 - 6.4 *Selecting ports on the card*..... 87
 - 6.5 *Port list options* 88
 - 6.6 *Port number*..... 89
 - 6.7 *Port function* 89
 - 6.8 *Label*..... 89
 - 6.9 *Description* 89
 - 6.10 *Search Ports*..... 89
 - 6.11 *Search Properties*..... 90
 - 6.12 *System configuration limits* 91
 - 6.13 *System hardware limits*..... 91
 - 6.14 *Go Live configuration* 93
- 7 *Applying Eclipse HX changes*94**
 - 7.1 *Apply map to matrix*..... 94
 - 7.2 *Apply to all matrices*..... 97
 - 7.3 *Preserving locally assigned keys*..... 97
 - 7.4 *Apply changes to all matrices* 97
 - 7.5 *Configuration application preferences* 98
- 8 *Adding and configuring an MVX-A16 card*.....100**
 - 8.1 *Adding an MVX-A16 card (automatic discovery)* 100
 - 8.2 *Adding an MVX-A16 card (manual)*..... 100
 - 8.3 *Removing an MVX-A16 card* 102
 - 8.4 *Setting the port function* 103
 - 8.5 *Port properties* 106
- 9 *Adding and configuring an E-QUE card*138**

9.1	<i>Adding an E-Que card (automatic discovery)</i>	138
9.2	<i>Adding an E-Que card (manual)</i>	138
9.3	<i>Removing an E-Que card</i>	141
9.4	<i>Setting the port function</i>	142
9.5	<i>E-QUE E1 direct</i>	142
9.6	<i>E-QUE T1 direct</i>	146
9.7	<i>E-QUE E1 trunk</i>	147
9.8	<i>E-QUE T1 trunk</i>	149
9.9	<i>E-QUE E1 direct/trunk</i>	151
9.10	<i>E-QUE T1 direct/trunk</i>	153
9.11	<i>E-Que antenna/E-Que FS II-TA antenna</i>	155
9.12	<i>Configuring the antenna on an E-Que card</i>	156
9.13	<i>Configuring the antenna for an E-Que FS II card</i>	157
9.14	<i>E-Que splitter/E-Que FS II-TA splitter</i>	158
9.15	<i>Configuring an E-Que card for splitter</i>	159
9.16	<i>Configuring an E-Que FS II card for splitter</i>	160
9.17	<i>Antenna role map for FreeSpeak/CellCom</i>	160
9.18	<i>Antenna role map for FreeSpeak II™</i>	161
10	Adding and configuring an IVC-32 card	162
10.1	<i>Adding an IVC-32 card (automatic discovery)</i>	162
10.2	<i>Adding an IVC-32 card (manual)</i>	162
10.3	<i>Removing an IVC-32 card</i>	166
10.4	<i>Setting the port function</i>	167
10.5	<i>Port Properties</i>	168
10.6	<i>Adding and configuring an IVC-32 redundant card</i>	171
11	Adding and Configuring an LMC-64 card	176
11.1	<i>Adding an LMC-64 card (automatic discovery)</i>	176
11.2	<i>Adding an LMC-64 card (manual)</i>	176
11.3	<i>Removing an LMC-64 card</i>	180
11.4	<i>Port Properties</i>	180
12	Adding and configuring an E-FIB card	182
12.1	<i>Adding an E-FIB card (automatic discovery)</i>	182
12.2	<i>Adding an E-FIB card (manual)</i>	182
12.3	<i>Removing an E-FIB card</i>	184
12.4	<i>Port Properties</i>	185

13	Adding and configuring an E-MADI64 card	187
13.1	<i>Adding an E-MADI64 card (automatic discovery)</i>	187
13.2	<i>Adding an E-MADI64 card (manual)</i>	187
13.3	<i>Removing an E-MADI64 card</i>	189
13.4	<i>Setting E-MADI64 Card Properties</i>	189
13.5	<i>Setting the port function</i>	190
13.6	<i>Port Properties.....</i>	190
13.7	<i>Upgrading the E-MADI64 card firmware.....</i>	191
14	Adding and configuring an E-Dante64 card	194
14.1	<i>Adding an E-Dante64 card (automatic discovery).....</i>	194
14.2	<i>Adding an E-Dante64 card (manual)</i>	194
14.3	<i>Setting the E-Dante64 Card Properties</i>	196
14.4	<i>Setting the Port Function.....</i>	196
14.5	<i>Dante labels</i>	197
14.6	<i>Hardware name detection.....</i>	197
14.7	<i>Port Properties.....</i>	197
14.8	<i>Configuring the Dante interface.....</i>	198
14.9	<i>Upgrade your E-DANTE64-HX card</i>	212
15	Adding and configuring an E-IPA-HX card.....	216
15.1	<i>Licenses.....</i>	217
15.2	<i>Card capacity</i>	217
15.3	<i>Adding an E-IPA-HX card (automatic discovery)</i>	218
15.4	<i>Adding an E-IPA-HX card (manual)</i>	218
15.5	<i>Network setup for the E-IPA-HX card</i>	221
15.6	<i>Configure the E-IPA-HX card for IVC connections.....</i>	225
15.7	<i>Configure the E-IPA-HX card for FreeSpeak II</i>	229
15.8	<i>Convert to IPA facility</i>	236
15.9	<i>System monitoring</i>	237
15.10	<i>Troubleshooting</i>	239
15.11	<i>Upgrade the E-IPA-HX card</i>	241
16	General Purpose Inputs and Outputs	243
16.1	<i>General Purpose Inputs (GPIs).....</i>	243
16.2	<i>General Purpose Outputs (GPOs).....</i>	246
17	Panel programming	248
17.1	<i>The panel programming screen</i>	249

17.2	<i>The Palette</i>	251
17.3	<i>Stacked keys</i>	254
17.4	<i>Panel programming preferences</i>	256
17.5	<i>Key operation preferences</i>	257
17.6	<i>Expansion panels</i>	258
17.7	<i>V-Series panel programming</i>	259
17.8	<i>Concert panel programming</i>	266
17.9	<i>i-Series programming</i>	269
17.10	<i>Setting up assignment panel partyline membership options</i>	274
17.11	<i>Setting up assignment panel fixed group membership options</i>	275
17.12	<i>Agent-IC Mobile Client</i>	276
17.13	<i>ICS-1008 and ICS-1016 panels</i>	280
17.14	<i>ICS-22 panels</i>	282
17.15	<i>Local advanced</i>	283
17.16	<i>Fonts</i>	290
18	Configuring audio and conference routing	294
18.1	<i>Partylines</i>	294
18.2	<i>Fixed groups</i>	300
18.3	<i>Controls</i>	313
18.4	<i>Sort groups</i>	317
18.5	<i>Routes</i>	321
18.6	<i>Speed dials using SIP and TEL-14</i>	324
18.7	<i>Key groups</i>	326
18.8	<i>Logic</i>	331
19	Virtual Interruptible Foldbacks (IFBs)	332
19.1	<i>ISO and IFB preferences</i>	336
19.2	<i>Viewing and creating virtual IFBs</i>	339
19.3	<i>Configuring IFB properties</i>	342
20	Adding and configuring wireless devices	344
20.1	<i>CellCom/FreeSpeak Beltpacks</i>	344
20.2	<i>FreeSpeak II® (FS II) beltpacks</i>	353
20.3	<i>IP Transceivers (IPTs)</i>	378
21	Telephone audio routes in Eclipse matrices	379
21.1	<i>Telephone calls using LQ SIP</i>	379
21.2	<i>Telephone calls using TEL-14</i>	382

22	IP devices	388
22.1	<i>Introduction to IP devices.....</i>	388
22.2	<i>IP panel preferences.....</i>	389
22.3	<i>IP panels</i>	390
22.4	<i>Assigning a panel to an IVC-32 port.....</i>	395
22.5	<i>IP cards.....</i>	396
22.6	<i>IVC-32 IP settings.....</i>	397
22.7	<i>IVC-32 card panel list.....</i>	399
22.8	<i>Concert users</i>	402
23	Audio Mixer.....	407
23.1	<i>Introduction to Audio Mixer</i>	407
23.2	<i>Audio Mixer panel</i>	407
24	Go Live mode	421
24.1	<i>Introduction to Go Live mode.....</i>	421
24.2	<i>Entering Go Live mode.....</i>	422
24.3	<i>Using Go Live mode.....</i>	424
24.4	<i>Go Live limitations.....</i>	425
24.5	<i>Exiting Go Live mode.....</i>	426
25	Networking	427
25.1	<i>Network system configuration.....</i>	427
25.2	<i>Intelligent linking (trunking)</i>	431
25.3	<i>Programming remote labels.....</i>	449
25.4	<i>Remote fixed groups.....</i>	450
25.5	<i>Remote partylines</i>	451
25.6	<i>Remote 2-way radio</i>	452
25.7	<i>Remote telephone</i>	453
25.8	<i>Remote controls.....</i>	455
25.9	<i>Remote secondary actions.....</i>	456
25.10	<i>Remote IFBs.....</i>	456
26	Client server	457
26.1	<i>Client/server operation</i>	457
27	Using the diagnostic tools.....	465
27.1	<i>Crosspoint map.....</i>	465
27.2	<i>Matrix event log.....</i>	470

27.3 *Wireless status* 473

27.4 *System monitoring* 476

27.5 *E-DANTE-HX interface card*..... 479

27.6 *Resource chart* 480

27.7 *Save diagnostics information utility*..... 481

27.8 *Clear unused memory*..... 482

27.9 *Matrix event log and save diagnostics* 483

28 Glossary.....**484**

29 Limited Warranty**489**

30 Technical Support & Repair Policy**493**

SOFTWARE LICENSE AGREEMENT

IMPORTANT—THIS IS A LEGAL AGREEMENT BETWEEN YOU AND CLEAR-COM. BEFORE DOWNLOADING, ACCESSING, OR USING ANY PART OF THE SOFTWARE, YOU SHOULD READ CAREFULLY THE FOLLOWING TERMS AND CONDITIONS CONTAINED IN THIS SOFTWARE LICENSE AGREEMENT ("AGREEMENT") AS THEY GOVERN YOUR ACCESS TO AND USE OF THE SOFTWARE. CLEAR-COM IS WILLING TO LICENSE AND ALLOW THE USE OF THIS SOFTWARE ONLY ON THE CONDITION THAT YOU ACCEPT AND AGREE TO ALL OF THE TERMS AND CONDITIONS CONTAINED IN THIS AGREEMENT. IF YOU DO NOT AGREE WITH THIS AGREEMENT, YOU ARE NOT GRANTED PERMISSION TO ACCESS OR OTHERWISE USE THE SOFTWARE.

This Agreement applies to any computer program and related files (the "Software") offered to you by either Clear-Com LLC or HME Clear-Com Ltd. (each of whom is referred to herein as "Clear-Com") and whether the software is delivered in the form of a diskette, DVD, USB storage device or CD-ROM (the "Storage Media"), over the Internet or through an on-line network. Your use of the Software constitutes your acceptance of the following terms and conditions.

TERMS AND CONDITIONS

- 1) **License Grant.** The Software is provided by Clear-Com, and this Agreement provides to you a personal, revocable, limited, non-exclusive, royalty-free, non-transferable license to use the Software conditioned on your continued compliance with the terms and conditions of this Agreement. This Agreement permits you to use and access for personal or business purposes the Software only at a single physical location in connection with the use of Clear-Com products. You may also load information from the Software into your laptop, workstation, or computer temporary memory (RAM) and print and download materials and information from the Software solely for your personal or business use, provided that all hard copies contain all copyright and other applicable notices contained in such materials and information. If you are using the Software on behalf of a company or other form of entity, please note that such a company or entity may have a separate agreement with Clear-Com regarding access and usage privileges for the Software. Nevertheless, your use of the Software will be subject to the obligations and restrictions regarding use of the Software as set forth in this Agreement.
- 2) **Restrictions.** The license granted under this Agreement is limited. You may not use, copy, store, reproduce, transmit, distribute, display, rent, lease, sell, modify, alter, license, sublicense, or commercially exploit any data provided by Clear-Com through the Software in any manner not expressly permitted by this Agreement. In addition, you may not modify, translate, decompile, create any

derivative work(s) of, copy, distribute, disassemble, broadcast, transmit, publish, remove or alter any proprietary notices or labels, license, sublicense, transfer, sell, mirror, frame, exploit, rent, lease, private label, grant a security interest in, or otherwise use the Software in any manner not expressly permitted herein.

- 3) **User Obligations.** By downloading, accessing, or using the Software in order to view our information and materials or submit information of any kind, you represent that you are at least 18 years of age and will, at all times, provide true, accurate, current, and complete information when submitting information or materials on the software including, without limitation, when you provide information via a software registration or submission form. In addition, you agree to abide by all applicable local, state, national, and international laws and regulations with respect to your use of the software. This Agreement is also expressly made subject to any applicable export laws, orders, restrictions, or regulations.
- 4) **Proprietary Rights.** This Agreement provides only a limited license to access and use the Software. Accordingly, you expressly acknowledge and agree that Clear-Com transfers no ownership or intellectual property interest or title in and to the Software to you or anyone else. All text, graphics, user interfaces, visual interfaces, photographs, sounds, artwork, computer code (including html code), programs, software, products, information, and documentation as well as the design, structure, selection, coordination, expression, "look and feel," and arrangement of any content contained on or available through the Software, unless otherwise indicated, are owned, controlled, and licensed by Clear-Com and its successors and assigns and are protected by law including, but not limited to, United States copyright, trade secret, patent, and trademark law, as well as other state, national, and international laws and regulations. Except as expressly provided herein, Clear-Com does not grant any express or implied right to you or any other person under any intellectual or proprietary rights. Accordingly, your unauthorized use of the Software may violate intellectual property or other proprietary rights laws as well as other laws, regulations, and statutes. The name of the Software, the Clear-Com logo, and all other names, logos, and icons identifying Clear-Com and its programs, products, and services are proprietary trademarks of Clear-Com, and any use of such marks, including, without limitation, as domain names, without the express written permission of Clear-Com is strictly prohibited. Other service and entity names mentioned herein may be the trademarks and/or service marks of their respective owners.
- 5) **Feedback and Submissions.** Clear-Com welcomes your feedback and suggestions about Clear-Com's products or services or the Software. By transmitting any suggestions, information, material, or other content (collectively, "feedback") to Clear-Com, you represent and warrant that such feedback does not infringe or violate the intellectual property or proprietary

rights of any third party (including, without limitation, patents, copyrights, or trademark rights) and that you have all rights necessary to convey to Clear-Com and enable Clear-Com to use such feedback. In addition, any feedback received will be deemed to include a royalty-free, perpetual, irrevocable, transferable, non-exclusive right and license for Clear-Com to adopt, publish, reproduce, disseminate, transmit, distribute, copy, use, create derivative works, and display (in whole or in part) worldwide, or act on such feedback without additional approval or consideration, in any form, media, or technology now known or later developed for the full term of any rights that may exist in such content, and you hereby waive any claim to the contrary.

6) Limited Warranty.

- a) Clear-Com warrants that any Storage Media on which the Software is stored will be free from defects in materials and workmanship for 90 days from the date you acquire it. If a defect in the Storage Media occurs, return the Storage Media to Clear-Com and Clear-Com will replace it at no cost to you. This remedy is your exclusive remedy for breach of this warranty. This limited warranty is void if the damage or defect has resulted from accident, abuse or misapplication.
- b) WHILE CLEAR-COM ENDEAVORS TO PROVIDE RELIABLE INFORMATION, SERVICES, PROGRAMS, SOFTWARE, AND MATERIALS, EXCEPT AS SPECIFICALLY PROVIDED IN SECTION 6.1, THE SOFTWARE IS PROVIDED ON AN "AS-IS" AND "AS AVAILABLE" BASIS AND MAY INCLUDE ERRORS, OMISSIONS, OR OTHER INACCURACIES. YOU ASSUME THE SOLE RISK OF MAKING USE OF THE SOFTWARE. CLEAR-COM MAKES NO REPRESENTATIONS OR WARRANTIES ABOUT THE RESULTS THAT CAN BE ACHIEVED FROM OR THE SUITABILITY, COMPLETENESS, TIMELINESS, RELIABILITY, LEGALITY, OR ACCURACY OF THE SOFTWARE FOR ANY PURPOSE, AND EXPRESSLY DISCLAIMS ALL WARRANTIES, EXPRESS OR IMPLIED, INCLUDING, WITHOUT LIMITATION, ANY WARRANTY OF MERCHANTABILITY, FITNESS FOR A PARTICULAR PURPOSE, OR NON-INFRINGEMENT OR ANY OTHER IMPLIED WARRANTY UNDER THE UNIFORM COMPUTER INFORMATION TRANSACTIONS ACT AS ENACTED BY ANY STATE. CLEAR-COM ALSO MAKES NO REPRESENTATION OR WARRANTY THAT THE SOFTWARE WILL OPERATE ERROR FREE OR IN AN UNINTERRUPTED FASHION OR THAT ANY DOWNLOADABLE FILES OR INFORMATION WILL BE FREE OF VIRUSES OR CONTAMINATION OR DESTRUCTIVE FEATURES.

- 7) Limitation of Liability. You expressly absolve and release Clear-Com from any claim of harm resulting from a cause beyond Clear-Com's control, including, but not limited to, failure of electronic or mechanical equipment or communication lines, telephone or other connection problems, computer viruses, unauthorized access, theft, operator errors, severe weather, earthquakes, or natural disasters, strikes, or other labor problems, wars, or governmental restrictions. MOREOVER, IN NO EVENT SHALL CLEAR-COM BE LIABLE FOR ANY INDIRECT, PUNITIVE, INCIDENTAL, SPECIAL, EXEMPLARY, MULTIPLE, INDIRECT OR

CONSEQUENTIAL DAMAGES ARISING OUT OF OR IN ANY WAY CONNECTED WITH THE USE OF THE SOFTWARE, WITH ANY DELAY OR INABILITY TO USE THE SOFTWARE, OR FOR ANY INFORMATION, SERVICES, PROGRAMS, PRODUCTS, AND MATERIALS AVAILABLE THROUGH THE SOFTWARE, WHETHER BASED IN CONTRACT, TORT, STRICT LIABILITY, OR OTHERWISE, EVEN IF CLEAR-COM HAS BEEN ADVISED OF THE POSSIBILITY OF SUCH DAMAGES. BECAUSE SOME JURISDICTIONS DO NOT ALLOW THE EXCLUSION OR LIMITATION OF LIABILITY FOR CONSEQUENTIAL OR INCIDENTAL DAMAGES, THE ABOVE LIMITATION MAY NOT APPLY. NOTWITHSTANDING THE FOREGOING, TOTAL LIABILITY OF CLEAR-COM FOR ANY REASON WHATSOEVER RELATED TO USE OF THE SOFTWARE SHALL NOT EXCEED THE TOTAL AMOUNT PAID BY YOU TO CLEAR-COM TO PURCHASE THE SOFTWARE.

- 8) Indemnity. You agree to protect, defend, indemnify, and hold harmless Clear-Com and its affiliates and all of their respective employees, agents, directors, officers, shareholders, attorneys, successors, and assigns from and against any and all claims, proceedings, damages, injuries, liabilities, losses, costs, and expenses (including reasonable attorneys' fees and litigation expenses) relating to or arising from any breach by you of this Agreement.
- 9) Legal Matters.
 - a) If you are resident or domiciled anywhere other than Europe, the Middle East or Africa, this Agreement will be construed and enforced solely in accordance with the laws of the State of California, U.S.A., and courts in California shall have exclusive subject matter jurisdiction, personal jurisdiction, and venue to adjudicate any dispute arising out of this Agreement.
 - b) If you are resident or domiciled in Europe, the Middle East or Africa (the "EMEA"), this Agreement will be construed and enforced solely in accordance with English law and English Courts shall have exclusive subject matter jurisdiction, personal jurisdiction and venue to adjudicate any dispute arising out of this Agreement.
 - c) You agree to waive any right to a jury trial in connection with any action or litigation in any way arising out of or related to this Agreement and acknowledge that either party may seek attorney's fees in any proceeding. Any claim you might have against Clear-Com must be brought within two (2) years after the cause of action arises, or such claim or cause of action will be barred. You also acknowledge and agree that any applicable state law implementation of the Uniform Computer Information Transactions Act (including any available remedies or laws) shall not apply to this Agreement and is hereby disclaimed.
 - d) Clear-Com makes no representation that the Software is appropriate or available for use in locations outside the State of California or the EMEA and access to or use of the Software from states, territories, or nations where any aspect of the Software is illegal is prohibited. You access or use the Software on your own volition and are responsible for compliance with all applicable local laws with respect to your access and use of the Software.

- e) A printed version of this Agreement and of any related notice given in electronic form shall be admissible in judicial or administrative proceedings based upon or relating to this Agreement to the same extent and subject to the same conditions as other business documents and records originally generated and maintained in printed form.
 - f) Clear-Com has no obligation to provide free updates to or upgrades of the Software or to provide support of any kind with respect to the Software.
 - g) If you are acquiring the Software for an agency of the United States Government, the provisions of Federal Acquisition Regulations Section 12.212 or Department of Defense FAR Supplement Section 227.7202-3, as applicable, apply to such acquisition.
- 10) **Term and Termination.** This Agreement and your right to use the Software will take effect at the moment you click "I ACCEPT" or you install, access, or use the Software and is effective until terminated as set forth below. This Agreement will terminate automatically if you click "I REJECT." In addition, Clear-Com reserves the right at any time and on reasonable grounds, which shall include, without limitation, any reasonable belief of fraudulent or unlawful activity or actions or omissions that violate any term or condition of this Agreement, to deny your access to the Software or to any portion thereof in order to protect its name and goodwill, its business, or other authorized users, and this Agreement will also terminate automatically if you fail to comply with this Agreement, subject to the survival rights of certain provisions identified below. Termination will be effective without notice. You may also terminate this Agreement at any time by ceasing to use the Software, but all applicable provisions of this Agreement will survive termination, as identified below. Upon termination, you must destroy all copies of any aspect of the Software in your possession. In addition to the miscellaneous section below, the provisions concerning Clear-Com's proprietary rights, feedback, indemnity, disclaimers of warranty, limitation of liability, and governing law will survive the termination of this Agreement for any reason.
- 11) **Miscellaneous.** You acknowledge that any breach, threatened or actual, of this Agreement will cause irreparable injury to Clear-Com, such injury would not be quantifiable in monetary damages, and Clear-Com would not have an adequate remedy at law. You therefore agree that Clear-Com shall be entitled, in addition to other available remedies, to seek and be awarded an injunction or other appropriate equitable relief from a court of competent jurisdiction restraining any breach, threatened or actual, of your obligations under any provision of this Agreement. Accordingly, you hereby waive any requirement that Clear-Com post any bond or other security in the event any injunctive or equitable relief is sought by or awarded to Clear-Com to enforce any provision of this Agreement. The parties agree that this Agreement is for the benefit of the parties hereto as well as Clear-Com's licensors. Accordingly, this Agreement is personal to you, and you may not assign your rights or

obligations to any other person or entity without Clear-Com's prior written consent. Failure by Clear-Com to insist on strict performance of any of the terms and conditions of this Agreement will not operate as a waiver by Clear-Com of that or any subsequent default or failure of performance. If any provision (or part thereof) contained in this Agreement is determined to be void, invalid, or otherwise unenforceable by a court of competent jurisdiction or on account of a conflict with an applicable government regulation, such determination shall not affect the remaining provisions (or parts thereof) contained herein and the illegal, invalid, or unenforceable clause shall be modified in compliance with applicable law in a manner that most closely matches the intent of the original language. No joint venture, partnership, employment, or agency relationship exists between you and Clear-Com as a result of this Agreement or your utilization of the Software. Headings herein are for convenience only. This Agreement represents the entire agreement between you and Clear-Com with respect to use of the Software, and it supersedes all prior or contemporaneous communications and proposals, whether electronic, oral, or written between you and Clear-Com with respect to the Software.

1 Introduction to EHX Configuration Software

EHX Configuration Software (EHX) is used to create and manage communication pathways between your Eclipse HX devices, including matrices, interface cards, interface modules and user panels.

This guide describes the features of EHX, and helps you to use the software to build and configure a matrix intercom system.

For example, use EHX software to:

- Create individual, point-to-point talk and listen paths between members of a matrix intercom system.
- Create groups and one-to-many calls (fixed groups).
- Store complete system setups (configurations) on the EHX PC.
- Apply and instantly implement a configuration on the matrix.
- Store four complete configuration maps in the matrix on-board memory, any of which can be activated immediately from the front of the matrix with the push of a button.
- Communicate with CellCom®, FreeSpeak® and FreeSpeak II™ beltpacks allowing direct communication between panels and roaming users.
- Communicate with remote panels over IP.
- Interface with the Clear-Com Concert™ multi-user conferencing system over IP.
- Interface with HelixNet Partyline™, the Clear-Com digital partyline system.
- Interface with telephones, two-way radios, camera intercoms, and more.
- Bring an outside audio source, such as program source, into the system's audio stream and interrupt the program audio for announcements (IFBs).
- Activate an applause light in a studio, a lock on a door, or other control functions each time an external device such as a switch is triggered.
- Control, monitor, or run diagnostics on a matrix system remotely from anywhere, if the matrix is set up on a LAN network.
- Link matrices worldwide.

1.1 System components

A complete Eclipse HX system comprises the Eclipse HX configuration software (EHX), a central hardware matrix, user panels and other remote devices - interfaces, four-wire equipment—connected to the matrix. A matrix and connected devices operate in a star

configuration, with each device connecting back to the matrix directly. Audio signals are routed through the central matrix and out to the connected audio devices in accordance with the configuration created in EHX.

The following sections give a brief overview of the matrix system.

1.1.1 Central matrix

The matrix hardware assembly comprises the following components:

- The metal housing (sometimes called the chassis or frame).
- The central processing unit (CPU).
- The internal circuitry which controls the attached devices.
- Power supplies.
- The rear panel interfaces which link the matrix to user panels and remote devices.

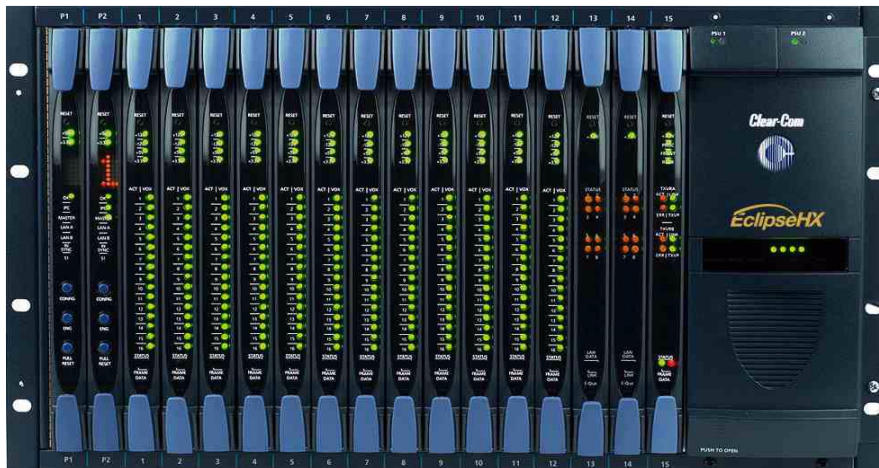

Figure 1-1 Eclipse HX-Omega Matrix

Chassis

The matrix chassis (frame) is a metal rectangular container which houses the matrix internal circuitry and power supplies, as follows:

- The Eclipse HX-Omega, Eclipse HX-Median and Eclipse HX-Delta are designed to host removable CPU cards, interface cards, and interface modules.
- The Eclipse HX-PiCo contains fixed internal circuitry.

The larger matrices (Eclipse HX-Omega, Eclipse HX-Median and Eclipse HX-Delta) have removable power supplies, which can be exchanged when necessary.

Central processing unit (CPU)

The central processing unit (CPU) provides the serial data and Ethernet connection to the PC hosting the EHX software.

The CPU also coordinates the data flow for other features of the system, such as general-purpose outputs and inputs. The CPU stores four complete system configurations in its memory, which can be retrieved and activated directly from the matrix front-panel controls, even when the matrix is not connected to a computer.

Each matrix system contains at least one central processing unit, located either on its own removable CPU card, or in internal circuitry.

The Eclipse HX-Omega, Eclipse HX-Median and Eclipse HX-Delta are supplied with two CPU cards (in a master and slave relationship), ensuring fail-safe operation.

Interface cards/PiCo matrix

The matrix interface cards control the operation of the panels and interface modules connected to them. Panels and interfaces connect to the interface cards through an RJ-45 connector, or port, on the rear panel of the matrix. The interface card sends balanced duplex audio and RS-422 data signals to and from connected audio equipment.

Power supplies

Each Eclipse HX-Median, Eclipse HX-Omega or Eclipse HX-Delta matrix can hold two independent power supplies. These may be connected to a main and backup power source for redundancy. If one of these power supplies fails, the second supply automatically takes over.

In the event of a complete power failure, a matrix can automatically restore itself to complete functioning by retrieving configuration information from its non-volatile operational memory.

The Eclipse HX-PiCo matrix has dual AC power supplies which can operate independently.

1.1.2 Eclipse HX configuration software (EHX)

The Eclipse HX configuration software (EHX) controls the operation of the system's connected audio devices, using a configuration (sometimes called a configuration map) that is applied to the matrix.

EHX can also be used to monitor the matrix for faults and to log errors for analysis.

1.2 Setting up an Eclipse HX matrix system

The following procedure shows the basic steps for setting up an Eclipse HX matrix system. For more quick start information, see the *Eclipse HX Quick Start Guide*. For detailed installation information, see the *Eclipse HX Installation Guide*.

To set up an Eclipse HX matrix system:

- Ensure that there is a working connection between the EHX PC and the matrix (see section **2.3.3 Importing your projects and configurations** into EHX).

To import a saved project from an earlier version of EHX or ECS into EHX in **Client-only** mode:

- 1) Open EHX. Select **File > Open**.
- 2) Navigate to the project file (*.hxn or *.ccn format) saved to your hard drive. Click **Open**.
- 3) If you import a .ccn file, remember to save your imported project as an *.hxn format file.

To import a saved project from an earlier version of EHX or ECS into EHX in **Client-Server** mode:

- 1) Open EHX. Select File > Import Project.
- 2) Navigate to the project file (*.hxn or *.ccn format) saved to your hard drive. To import the file, click **Open**.

Note: Remember to save your project, after opening it.

- 3) Repeat the above procedure for all the projects you want to import.

1.3 Further information

For more information about the Eclipse HX matrix system, including matrices, interface cards, interface modules and user panels, see the complete Eclipse® HX documentation set, available from both the Clear-Com website (www.clearcom.com) and the Eclipse HX software and documentation DVDs.

2 Getting started with EHX

2.1 System requirements

EHX 10.0 runs on the following versions of Windows:

- Microsoft Windows 7 (32-bit and 64-bit).
- Microsoft Windows 8.1 (32-bit and 64-bit)
- Microsoft Windows 10 (32-bit and 64-bit)
- Microsoft Windows Server 2008 R2 (64-bit)
- Microsoft Windows Server 2012 R2 (64-bit)
- Microsoft Windows Server 2016 (64-bit)

Note: Operation on other platforms is no longer supported.

Note: When running EHX on Windows OS, you can run the client and server on separate machines, connected over the network.

The minimum requirements for the PC hosting EHX are as follows:

Specification	Value / Description
Processor	1 GHz
Memory	1 GB RAM
Hard Disk Free Space	2 GB
Input Devices	CD/DVD-ROM drive
Display Resolution	SVGA
User Entry	Keyboard, Mouse
Network	IEEE 802.3 Ethernet card and serial port

Table 2-1 Minimum PC Requirements

The recommended requirements for the PC hosting EHX are:

Specification	Value / Description
Processor	2 GHz for a client. As many cores as possible for a server
Memory	2 GB for a 32-bit client 3 GB for a 32-bit server 4 GB for a 64-bit client 4 GB for a 64-bit server
Hard Disk Free Space	2 GB
Display Resolution	1600 x 1200
Ports	One serial port and Ethernet port

Table 2-2 Recommended PC Requirements

2.2 Installing EHX

Note: If installing EHX on a system that uses a firewall, you must add specific exemptions for the EHX Server and Client in the firewall.

2.2.1 Backing up your existing projects and configurations

If you are upgrading from an earlier version of EHX/ECS, Clear-Com recommends backing up your projects and configurations before you install EHX.

Backing up ECS 5.2.x projects and configuration

To back up and export your existing ECS 5.2.x projects and configurations:

- 1) Open the project you want to export.
- 2) Select **File > Export Project**.
- 3) Save the project to a location on your hard drive. The project is saved as a *.ccn format file, which you can import later into EHX.

Note: EHX can open *.ccn format files as well as its own *.hxn format files.

- 4) Repeat the above procedure for all the projects you want to save.

Backing up EHX 7.x/8.x and above projects and configurations

To back up and export your EHX 7.x/8.x and above projects and configurations in **Client Only** mode:

- 1) Open the project you want to export.

- 2) Select **File > Save Project**.
- 3) Save the project to a location on your hard drive. The project is saved as a *.hxn format file, which you can import later into EHX.

Note: EHX can open *.ccn format files as well as its own *.hxn format files.

- 4) Repeat the above procedure for all the projects you want to save.

To back up and export your projects and configurations in **Client Server** mode:

- 1) Open the project you want to export.
- 2) Select **File > Export Project**.
- 3) Save the project to a location on your hard drive. The project is saved as a *.hxn format file, which you can import later into EHX.

Note: EHX can open *.ccn format files as well as its own *.hxn format files.

- 4) Repeat the above procedure for all the projects you want to save.

2.2.2 Uninstalling and reinstalling EHX

Configurations

If you are required to uninstall and re-install your EHX installation for any reason, ensure that you save your projects first for re-importing into EHX (see section **Note>Note: If installing EHX on a system that** uses a firewall, you must add specific exemptions for the EHX Server and Client in the firewall.

Backing up your existing projects and configurations and section **2.5 Importing your projects and configurations into EHX**). You can uninstall EHX from your Windows **All Programs** menu.

If you are running EHX in Client-Server mode, export your projects to a secure location on your hard drive in the same way as in **Note>Note: If installing EHX on a system that** uses a firewall, you must add specific exemptions for the EHX Server and Client in the firewall.

Backing up your existing projects and configurations.

2.2.3 Installing the EHX software

The Eclipse HX software USB or DVD contains the following executables for installing EHX. Run the required installation file, and follow the instructions that appear.

Installation *.exe	Description
EHXSetup.exe	Installer for the 32-bit and 64-bit versions of the EHX client (not including Dynam-EC). Use the EHX client version to connect directly to the matrix in Client-only mode or to an EHX server in Client-Server mode.
EHXDynam-ECSetup.exe	Installer for the 32-bit and 64-bit versions of the EHX client (including Dynam-EC). Use the EHX client version to connect directly to the matrix in Client-only mode or to an EHX server in Client-Server mode.
EHXServerSetup.exe	Installer for the 32-bit server and 64-bit server versions of EHX. The EHX server enables multiple EHX clients to work together when configuring an Eclipse HX system.

Table 2-3 EHX Installation Executables

Note: Before Installing EHX Server, please see section **Installing and Configuring IIS on the Server**.

2.3 Installing .NET Framework

Windows .NET is a software development framework. Some versions of Windows have .NET pre-installed, but if this is not the case and the EHX installer (EHXPMSetup.exe or EHXSetup.exe) encounters a problem when installing .NET, you must install it manually. To do so:

- 1) Go to the Microsoft website (www.microsoft.com) and download the appropriate version of .NET.

For example, for Windows 8.1 install .NET 4.5.1, for Windows 10 install .NET 4.6

- 2) Run the .NET installer.

Note: The .NET Framework 4 can be installed side-by-side with previous versions of the .NET Framework on a single computer. If IIS was previously enabled on the computer, the setup process for the .NET Framework automatically registers ASP.NET 4 with IIS. However, if you install the .NET Framework 4 before you enable IIS, you must run the ASP.NET IIS Registration tool to register the .NET Framework with IIS and create application pools that use the .NET Framework 4.

Open a command prompt and navigate to the folder
%WindowsDir%\Microsoft.NET\Framework\v2.0.50727\ and then enter the
following command:

```
aspnet_regiis.exe -i
```

This will register ASP.Net with IIS.

Note: You may have to have to reboot after installation.

- 3) If .NET is pre-installed on your version of Windows, you will be notified when running the installer. In this case, the appropriate version of .Net should be installed using the **Turn Windows Features On or Off** option from the Windows Control Panel. It is essential that you select all the following sub-options when installing .Net:
 - **.Net Framework 3.5**
 - Windows Communication Foundation HTTP Activation
 - Windows Communication Foundation Non-HTTP Activation
 - **.Net Framework 4.5 Advanced Services**
 - ASP.NET 4.5
 - WCF Services
 - HTTP Activation
 - Message Queuing (MSMQ) Activation
 - Named Pipe Activation
 - TCP Activation
 - TCP Port Sharing
- 4) Re-run the EHX installer.

2.4 Logging into EHX

2.4.1 Client-only mode

- 1) From the Windows **Start** menu, select **All Programs > Clear-Com > Eclipse HX Configuration System**. The EHX user login screen is displayed (see below). If you are logging in for the first time, the default username (Administrator) is already entered for you. No password is required on initial login

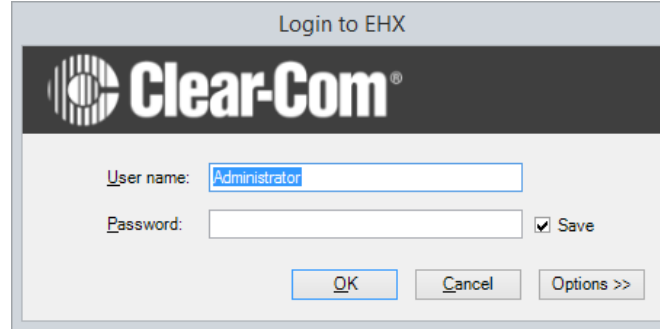

Figure 2-1 EHX Login Screen

- 2) Click **OK**.

When logged in to EHX, you can use the **User Management** facility to change the password for the default user and add further users (see section **2.5 Importing your projects and configurations into EHX**).

To import a saved project from an earlier version of EHX or ECS into EHX in Client-Server mode:

- 3) Open EHX. Select **File > Import Project**.
- 4) Navigate to the project file (*.hxn or *.ccn format) saved to your hard drive. To import the file, click **Open**.

Note: Remember to save your project, after opening it.

- 5) Repeat the above procedure for all the projects you want to import.

To import a saved project from an earlier version of EHX or ECS into EHX in Client-only mode:

- 1) Open EHX. Select **File > Open**.
- 2) Navigate to the project file (*.hxn or *.ccn format) saved to your hard drive. Click **Open**.

Note: If you import a .ccn file, remember to save your imported project as an *.hxn format file.

2.4.2 Client-Server mode

If you are running EHX in Client-Server mode, you must enter the address of the remote server before logging in.

To log into EHX in Client-Server mode:

- 1) From the Windows **Start** menu, select **All Programs > Clear-Com > Eclipse HX Configuration System**. The EHX user login screen is displayed (see below). If you are logging in for the first time, the default username (Administrator) is already entered for you. No password is required on initial login.

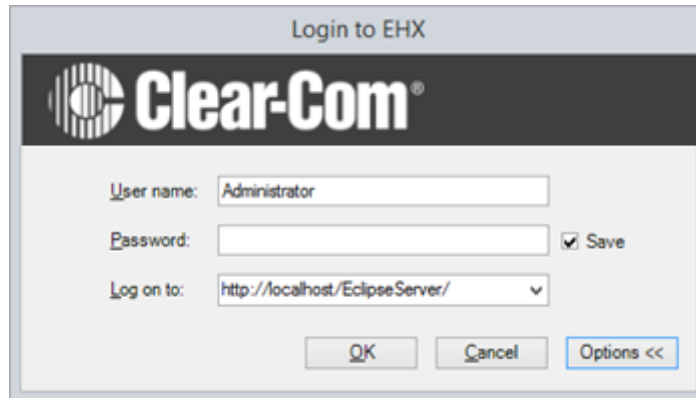

Figure 2-2 EHX Log in Server Option

- 2) Click **Options**.
- 3) Enter the address of the remote server to log into (for example, `http://RemoteHost:80/EclipseServer`). RemoteHost is the machine name or IP address of the machine running the EHX server software.
- 4) Click **OK**.

Note: The same versions of EHX must be installed to both the client and the server.

First screen after log in

After successfully logging in (either locally or to a server) the EHX initial screen is displayed.

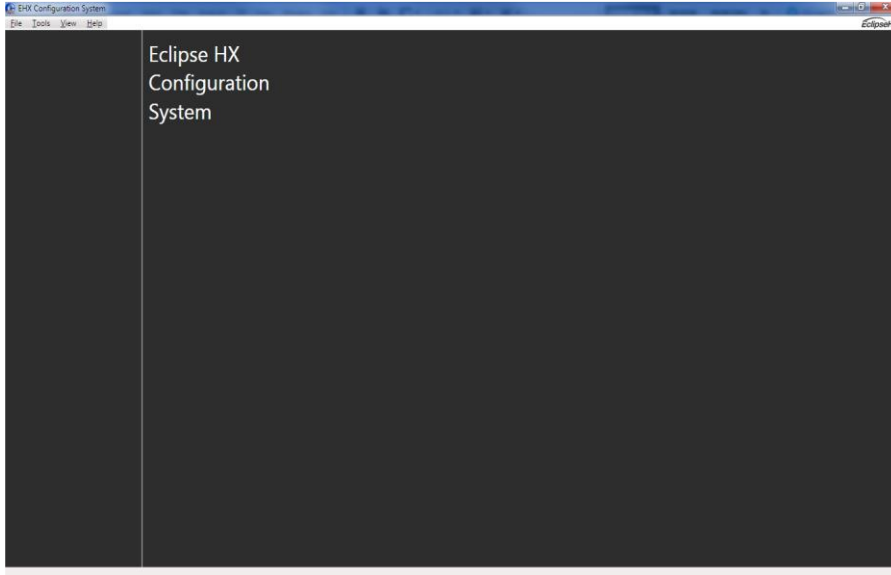

Figure 2-3 EHX Initial Screen

2.4.3 Identifying the EHX version

- 1) To identify the version of EHX, select **Help > About** on the Windows toolbar. An example of what you might see is shown below.



Figure 2-4 EHX About Screen

Note: The operational mode of EHX (Client-Only or Client-Server mode) is displayed, as well as the version of EHX.

2.5 Importing your projects and configurations into EHX

2.5.1 Client-only mode

- 1) Open EHX. Select **File > Open**.
- 2) Navigate to the project file (*.hxn or *.ccn format) saved to your hard drive. Click **Open**.

If you import a .ccn file, remember to save your imported project as an *.hxn format file.

2.5.2 Server-only mode

- 1) Open EHX. Select **File > Import Project**.
- 2) Navigate to the project file (*.hxn or *.ccn format) saved to your hard drive. To import the file, click **Open**.

Note: Remember to save your project, after opening it.

- 3) Repeat the above procedure for all the projects you want to import.

3 *Connecting a matrix*

3.1 Introduction

This chapter describes how to set up a new Eclipse HX matrix.

Note: For more detailed guidance, see the User Guide for each matrix.

Note: For information on setting the default IP address on Eclipse HX-Pico matrices, see the Eclipse HX-PiCo User Guide.

- 1) Reset the matrix to the factory default IP address (169.254.0.100):
The default IP address is a link local IP address. This means that the PC is connected directly to the matrix using an Ethernet cable, and communicates with the rack in DHCP mode. When the rack's IP configuration is defaulted back to the above link local address it also defaults to DHCP enabled.
- 2) The matrix is fitted with two CPU cards, in a master and slave relationship. Remove the slave CPU card.

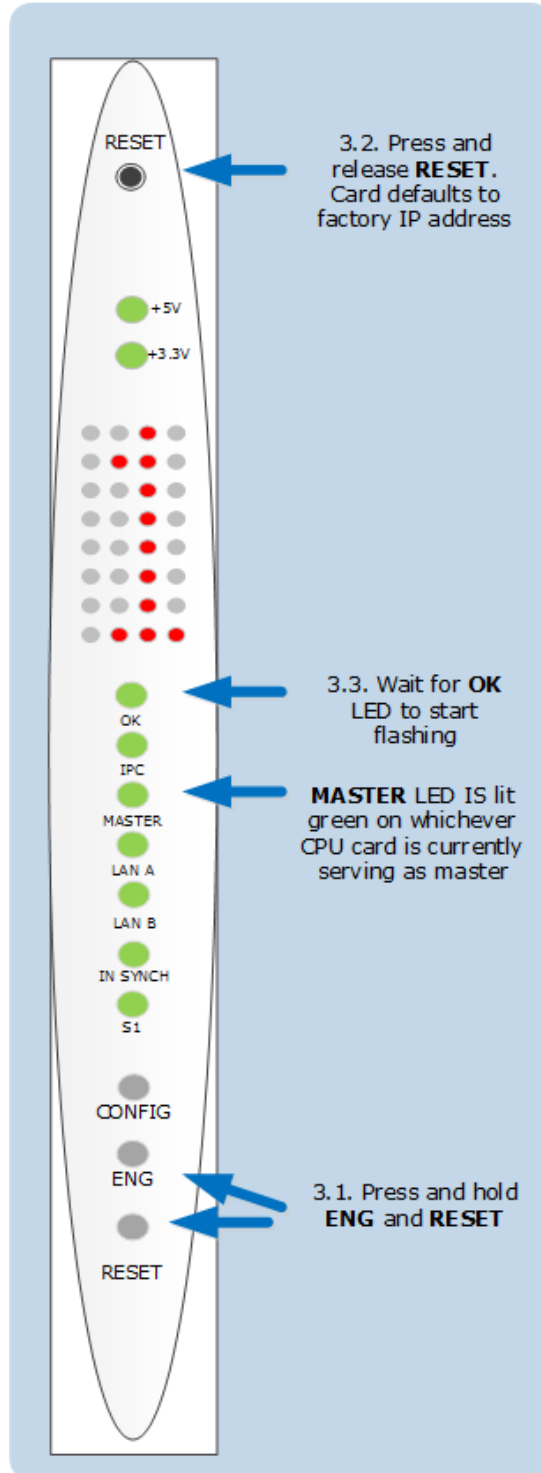

Figure 3-1 CPU Card

- 3) Press and hold the **ENG** and **FULL RESET** front panel buttons simultaneously (bottom of card), and at the same time press and release the **RESET** button

(top of card) on the master CPU card. Keep the ENG and FULL RESET buttons pressed, and wait for the OK LED to start flashing. Then release the ENG and FULL RESET buttons.

- 4) Replace the slave CPU card.
- 5) Ensure that the matrix and the EHX PC are connected directly using an Ethernet connection.
- 6) Configure the Ethernet connection on the EHX PC, then create a configuration with the factory default IP address. Ensure that the PC is set to DHCP mode.
- 7) Apply the complete configuration map to the matrix, using the factory default IP address.
- 8) Clear-Com recommends that the matrix is given a fixed/static IP address after the initial configuration is applied. Contact your IP administrator.

3.2 Cabling recommendations

The following table outlines Clear-Com’s recommendations about cabling.

Clear-Com CAT5e/6a cable recommendations	
Category (CAT)	<p>Higher CAT numbers will support a higher bandwidth. Therefore, by using a higher CAT number, you are future proofing your system to some extent.</p> <p>Example:</p> <ul style="list-style-type: none"> • Cat5: up to 1G • Cat6a: up to 10G. <p>Use CAT5e or higher.</p>
American Wire Guage (AWG)	<p>The lower the AWG number, the less temperature rise there will be in the cable when using PoE. This is particularly important for bundles. Local building regulations may rule out the use of 26AWG or higher, depending on the installation. Check with your local building regulations.</p> <p>Use AWG 24 or lower.</p>
Shielded Twisted Pair (STP) or Foiled Twisted Pair (FTP)	<p>Using shielded cable means less problems with interference from other sources. This means that your network will be more robust if you use shielded cables.</p>
Overall Recommendation	<p>Use CAT6a 23 AWG STP cable.</p>

3.3 Matrix Ethernet operation

The Eclipse HX-Omega, Eclipse HX-Median and Eclipse HX-Delta CPU card Ethernet ports are normally connected to a LAN and used to communicate with clients such as EHX and Dynam-EC. The Ethernet port functionality depends on the IP address setup. If an IP address of 0.0.0.0 is configured on the second Ethernet port, it is not used for Tx or Rx. This is the default setup if the default IP address is set as described above.

Ethernet is the recommended connection type for all applications. Serial connections are limited to a single matrix, have a limited range of functionality and should only be used for backup purposes.

If the redundant Ethernet mode is enabled, all matrix to matrix traffic is sent out on both Ethernet ports. This applies to both directed and broadcast packets. All matrix to matrix traffic is also received on both Ethernet ports. If the traffic is transaction related, the second (duplicate) message received is not consumed, but simply dropped.

The matrices listen for client connections on both Ethernet ports. Once the connection is made it is added to the list of connections to service. Broadcast type Tx data is duplicated out on each connection (for example, an HCI connection to the matrix from 3rd party applications).

The EHX PC makes a connection on either the main or backup Ethernet port of each system in the linked set. If both are up, this defaults to the primary port. If connection is lost to the currently active port on a matrix, EHX swaps over to using the other Ethernet port. If this connection is lost only on one matrix in a linked set, the others are not affected.

Note: Matrices are shipped DHCP enabled, and with a default address. If there is no valid DHCP server, the address can be set manually. Right click on the matrix (which can be connected either by a serial or Ethernet connection), select **Change IP Settings**, and enter the new IP details.

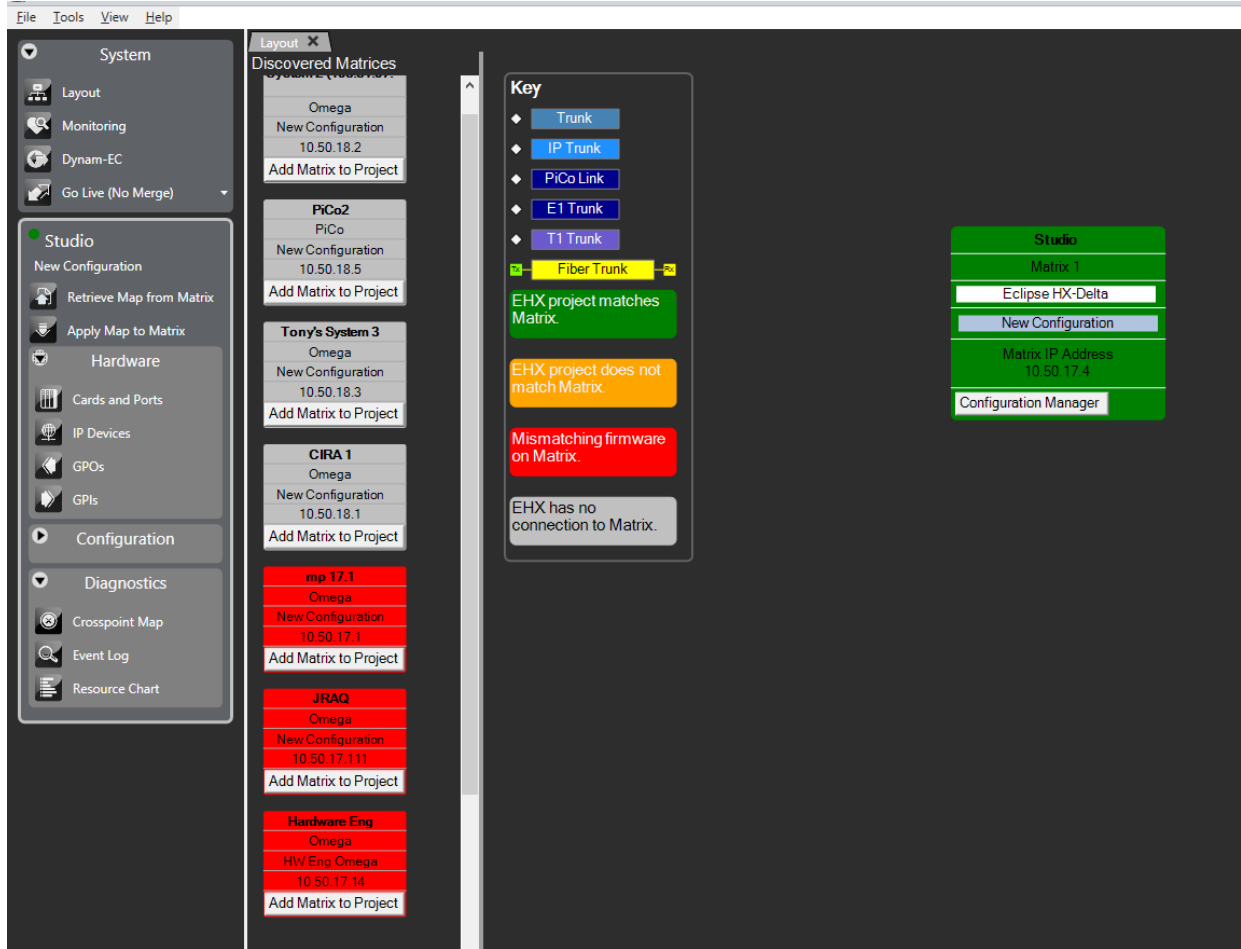

Figure 3-2 Change matrix IP address

Right-click the matrix and select **Change IP Settings**.

3.3.1 Configuration restrictions using dual LAN mode

The network ID (subnet) on the first Ethernet port must be different from that of the second port. The network ID is defined by the IP address and the network mask for the port.

For example:

A network address of 172.16.2.1 and a mask of 255.255.0.0 give a network ID of 172.16. Therefore, in this scheme the second port could not have an IP address starting with 172.16. (but could be 172.17.xx)

If the network mask is extended to 255.255.255.0 the network ID becomes 172.16.2. This means that the second port could have an address of 172.16.3.1 and a mask of 255.255.255.0, giving a network ID of 172.16.3 for the second port.

Note: If both Ethernet ports are set up with the same network ID, this condition results in data loss on one or both Ethernet ports.

Clear-Com does not recommend Ethernet redundancy and the use of a default gateway. An IP address and gateway combination on an Ethernet port means that all Tx traffic to any address is possible on the port. Traffic that matches the other Ethernet port can therefore be sent out on the wrong port. **If Ethernet redundancy mode is enabled, then no gateway settings should be entered for the matrix IP settings.**

3.4 Selecting Ethernet or serial connection

EHX can communicate with a matrix using one of the following methods:

- Ethernet connection.
- Serial connection if the EHX PC is connected directly to the matrix via an RS-232 cable. For more information, see section **3.4.3 Serial connection**.

3.4.1 Ethernet connection

To select an Ethernet connection:

Select **Tools > Matrix Connection**, and select the **Ethernet** radio button.

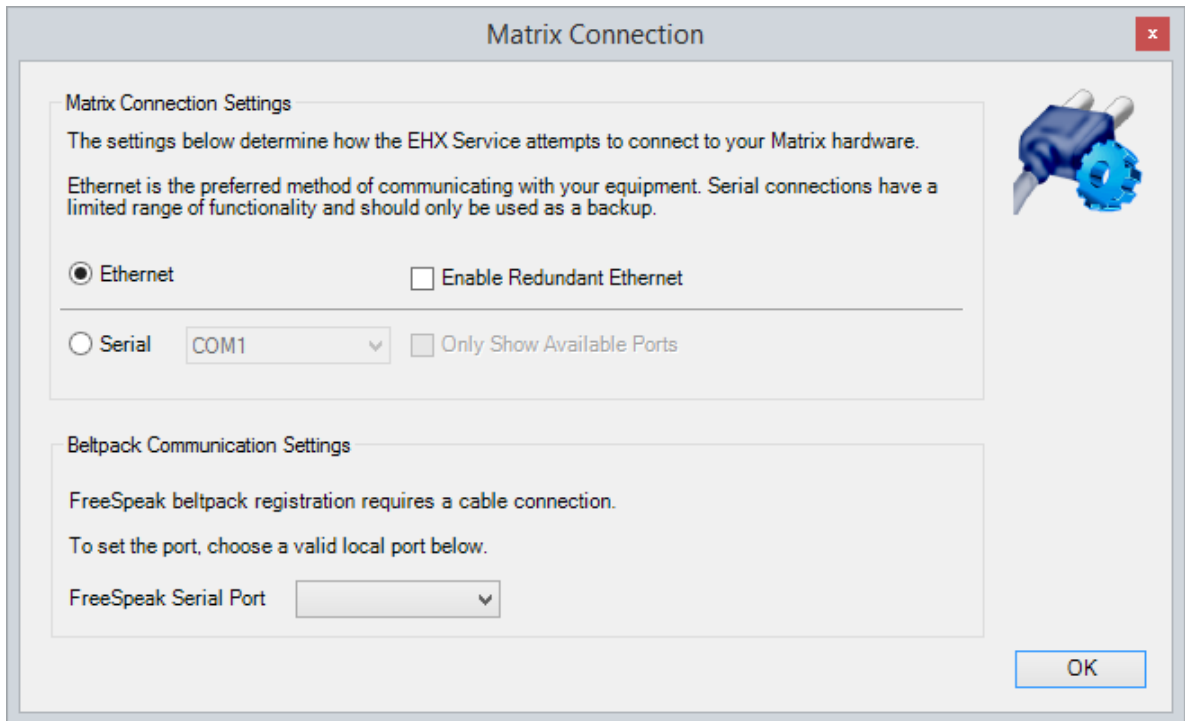

Figure 3-3 Matrix Connection

Note: You can also select the **Enable Redundant Ethernet** radio button. For more information, see section **3.2 Cabling recommendations**

Note: The following table outlines Clear-Com’s recommendations about cabling.

Clear-Com CAT5e/6a cable recommendations	
Category (CAT)	<p>Higher CAT numbers will support a higher bandwidth. Therefore, by using a higher CAT number, you are future proofing your system to some extent.</p> <p>Example:</p> <ul style="list-style-type: none"> • Cat5: up to 1G • Cat6a: up to 10G. <p>Use CAT5e or higher.</p>
American Wire Guage (AWG)	<p>The lower the AWG number, the less temperature rise there will be in the cable when using PoE. This is particularly important for bundles. Local building regulations may rule out the use of 26AWG or higher, depending on the installation. Check with your local building regulations.</p> <p>Use AWG 24 or lower.</p>
Shielded Twisted Pair (STP) or Foiled Twisted Pair (FTP)	<p>Using shielded cable means less problems with interference from other sources. This means that your network will be more robust if you use shielded cables.</p>
Overall Recommendation	<p>Use CAT6a 23 AWG STP cable.</p>

Note: Matrix Ethernet operation.

The PC is usually connected to the matrix using:

- The LAN1 connector (a standard RJ45 connector) on the rear of the Eclipse HX-Median, Eclipse HX-Omega or Eclipse HX-Delta matrix.
LAN1 is the default connector on the matrix. LAN2 (also a standard RJ45 connector) is not configured when it leaves the factory, and must be enabled in EHX.
- The LAN connector (a standard RJ45 connector) on the rear of the Eclipse HX-PiCo.

A ferrite core must be added to the socket end of each Ethernet cable to comply with European EMC standards. A suitable ferrite core is Wurth Elektronik part: 74271132. Shielded CAT5e/6 cable is recommended for Electro Magnetic Compliance in EU countries.

A crossover cable should be used (though a straight-through CAT5 cable can be used with a switch and a modern PC manufactured after 2010):

Pin	Function
Pin 1	Transmit data +
Pin 2	Transmit data -
Pin 3	Receive data +
Pin 4	N/C
Pin 5	N/C
Pin 6	Receive data -
Pin 7	N/C
Pin 8	N/C

Table 3-1 Pin Assignments for LAN Connectors

To establish communication between the PC and the Eclipse HX matrix, the PC and the matrix must be set to the same subnet. Windows provides many different methods of reconfiguring network settings.

Reconfiguring network settings in Windows 7

This section explains how to configure Windows 7 to work with the matrix in its default 169.xx link local setting.

Note: To establish communication between the PC and the Eclipse HX matrix, the PC and the matrix must be set to the same subnet.

- 1) Navigate to **Start > Control Panel > Network and Internet > Network and Sharing Centre**. The following screen appears:

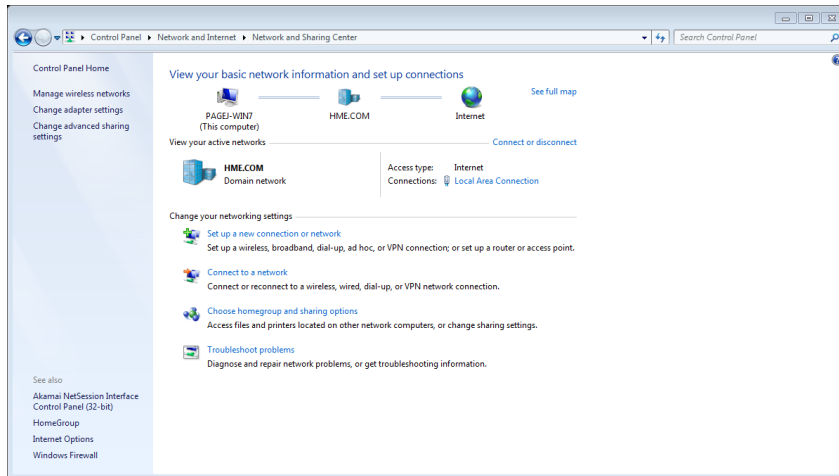

Figure 3-4 Network and Sharing Center

2) Select **Local Area Network**. The following screen appears:

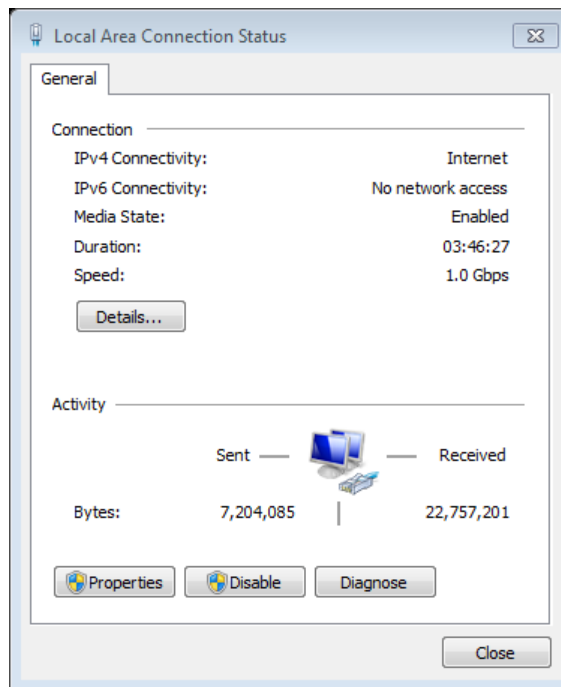

Figure 3-5 Local Area Network Status

3) Select **Properties**. The following screen appears:

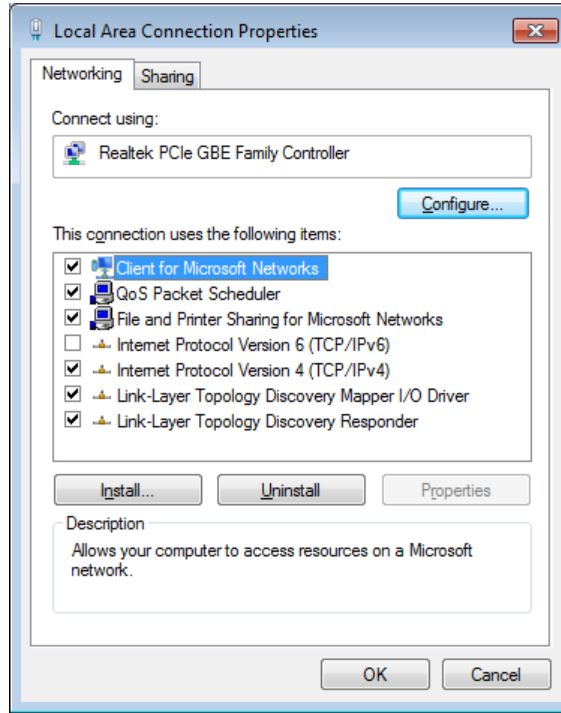

Figure 3-6 Local Area Connection Properties

- 4) Select **Internet Protocol Version 4**, and then select **Properties**. The following screen appears:

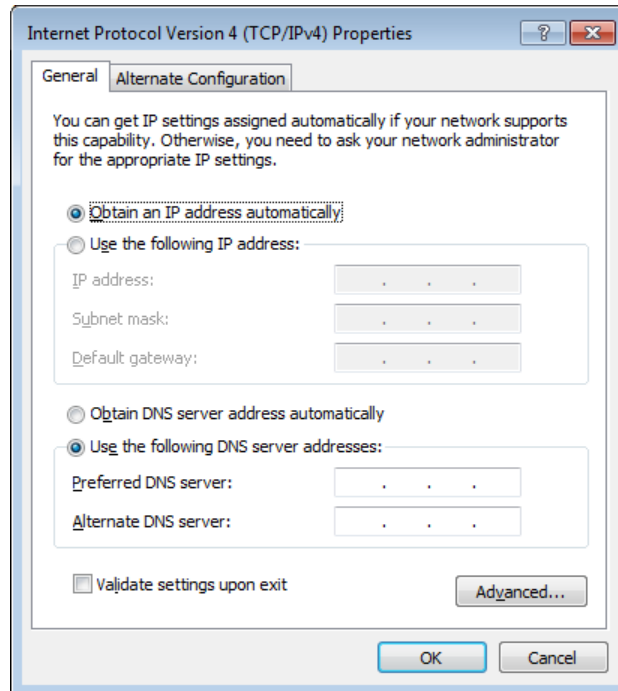

Figure 3-7 Internet Protocol Version 4

- 5) Select **Use the following IP address**, and then enter the correct IP address (169.254.0.10) and Subnet mask (255.255.0.0), and then click **OK**.

Note: If your matrix has a fixed/static IP address, set your PC to be in the same IP address range.

Note: To establish communication between the PC and the Eclipse HX matrix, the PC and the matrix must be set to the same subnet.

Reconfiguring network settings in Windows 8.1

Navigate to **Start > Control Panel > Network and Internet > Network and Sharing Center**. The following screen appears:

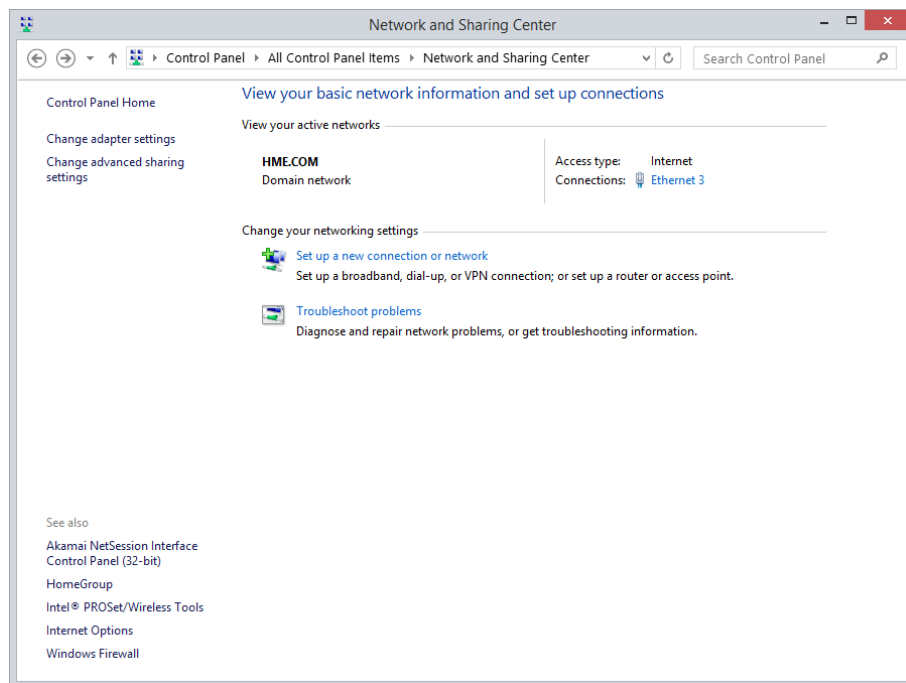

Figure 3-8 Network and Sharing Center

- 6) Select **Ethernet 3**. The following screen appears:

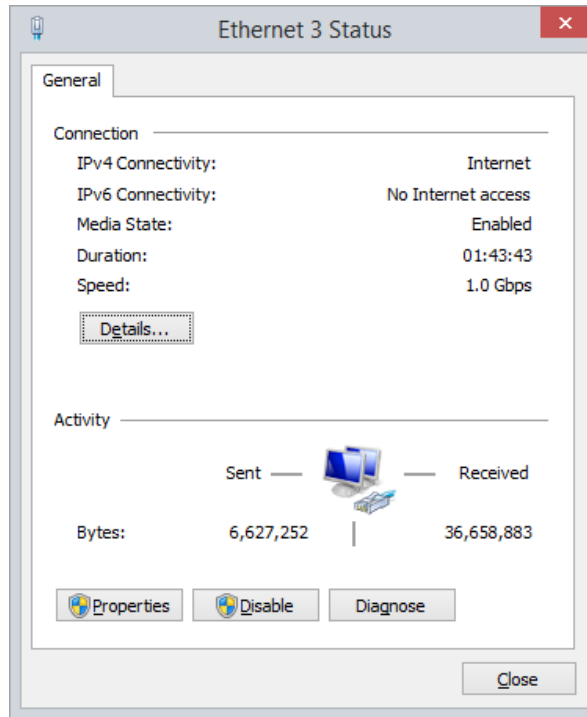

Figure 3-9 Ethernet 3 Status

7) Select **Properties**. The following screen appears:

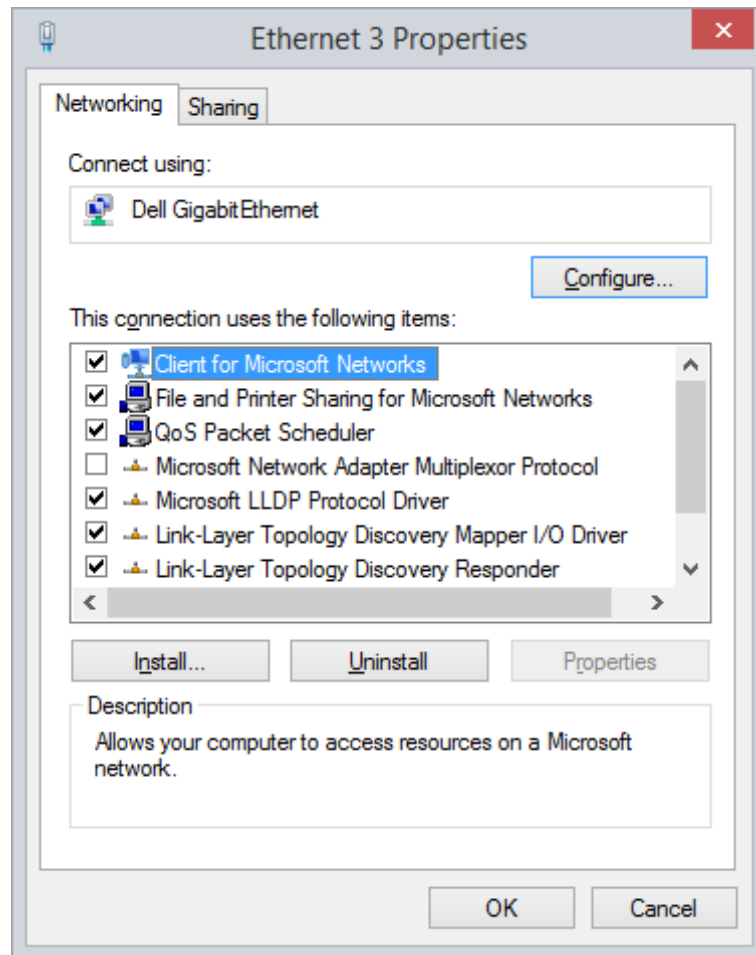

Figure 3-10 Ethernet 3 Properties

- 8) Select **Internet Protocol Version 4**, and then select **Properties**. The following screen appears:

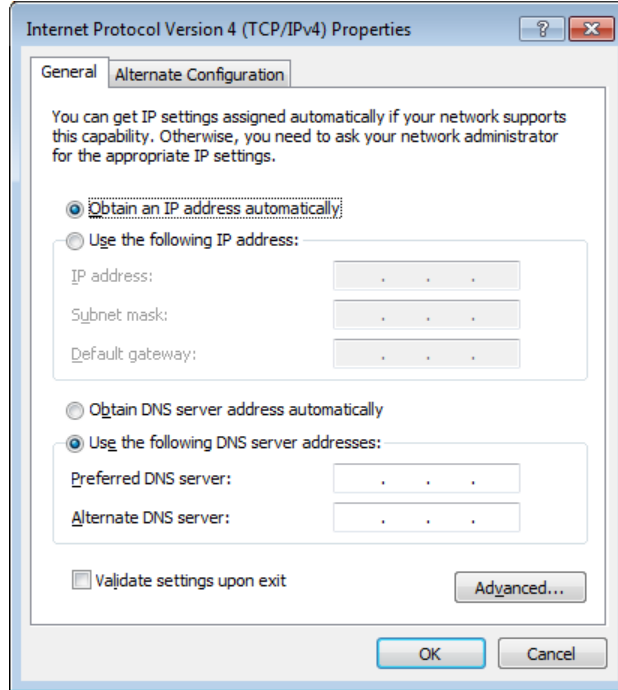

Figure 3-11 Internet Protocol Version

- 9) Select **Use the following IP address**, and then enter the correct IP address (169.254.0.10) and Subnet mask (255.255.0.0), and then click **OK**.

Note: If your matrix has a fixed/static IP address, set your PC to be in the same IP address range.

Note: To establish communication between the PC and the Eclipse HX matrix, the PC and the matrix must be set to the same subnet.

Checking Ethernet connections with the Windows ping utility

If there is a problem connecting to the Eclipse HX matrix, you can use the Windows Ping utility on Ethernet to verify that the cabling and IP settings are correct.

To check the connection to the matrix with Ping:

- 1) From the Windows **Start** menu, select **Run**.
The Run dialog is displayed.
- 2) To open the command window, type `cmd` in the **Open** field and click **OK**.
- 3) Type `ping xxx.xxx.xx.xxx`, where the X's represent the IP address of the Eclipse HX matrix.

- 4) Press **Enter**.

If the ping was successful, a reply is received. If the ping was not successful check the cabling and IP settings.

Note: When checking the connection, ensure that Network Bridging and any firewalls are disabled.

Note: If you have an Omega, Median or Delta matrix, press and release the ENG button on the master CPU card to display its IP address on its dot matrix display.

Note: If you have a PiCo matrix, go to **Menu > System > Info** to view the IP address of the matrix.

3.4.2 Changing matrix IP address using matrix event log

It may be necessary to change the IP address of a matrix. It is recommended that the following steps be followed when the right click layout screen IP setting change is not available, for example when the serial interface is the only available interface. The sequence of steps to change the IP address of a matrix via the event log is:

- 1) After starting EHX open the configuration.
- 2) Ensure that the PC is connected to the matrix via Ethernet or a serial link.
- 3) Open Matrix Event Log from the Diagnostics menu (see section **27 Using the diagnostic tools** for details on the Matrix Event Log).

Note: To display the Diagnostics menu at least one matrix must be configured on the layout pane.

- 4) To connect to the matrix, press **Play**.

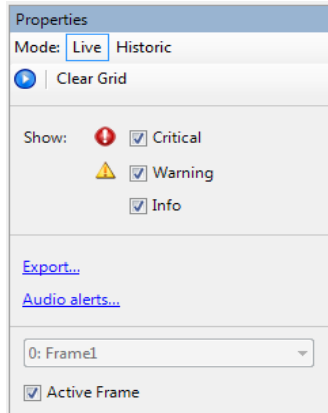

Figure 3-12 Press Play to Connect to Matrix

- 5) When connection is established click on the **Request Info** button which is displayed beside the **Play** icon.

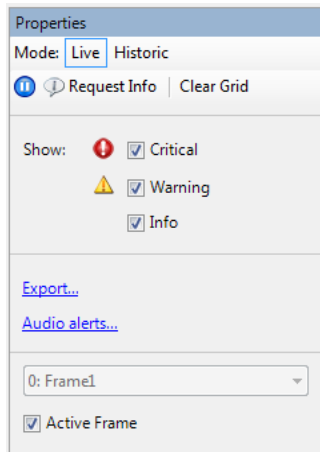

Figure 3-13 Request Info Button

- 6) Choose **Change IP Address** from the list in the left-hand pane and enter the desired values listed below.

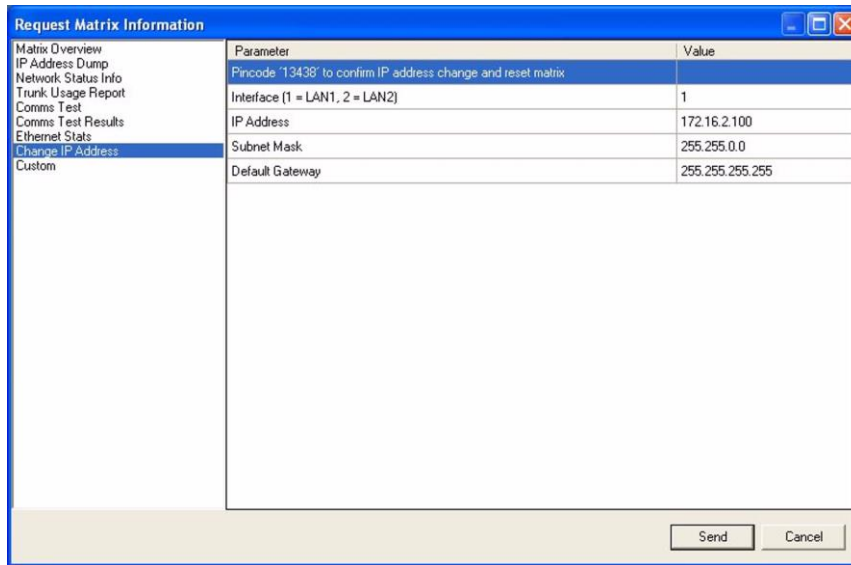

Figure 3-14 IP Address Entry

- Select parameter 1 and enter the pin code.
 - Select parameter 2 and enter interface 1 and then enter the LAN1 port address.
 - Select parameter 2 and enter interface 2 and then enter the LAN2 port address (Omega, Median and Delta matrix only).
 - Select parameter 3 and enter the subnet mask.
 - Select parameter 4 and enter the default gateway address.
- 7) Click on **Send** to update the matrix.
 - 8) A message from the Matrix indicating that the change was successful is seen in the log, and the matrix resets.
 - 9) Close Matrix Event Log, and open **Systems > Layout**.
 - 10) Change the IP address in **Systems > Layout** to be the same as the new value in the matrix.
 - 11) Press **File > Save**.

Note: It may be necessary to change the IP address and subnet mask of the PC if the new matrix IP address is from a different network range.

3.4.3 Serial connection

Note: Ethernet is the recommended connection type for all applications. Serial connections are limited to a single matrix, have a limited range of functionality and should only be used for backup purposes.

To establish a serial connection between the EHX PC and the matrix the hardware must be connected first and then the software configured.

To establish the hardware connection, connect a serial (RS-232) cable between the computer's serial port and the connector labelled RS-232 on the rear of the Eclipse HX matrix.

To set up a serial connection between EHX and the Eclipse HX matrix:

- 1) From the EHX command line, open the **Tools** menu and select **Matrix Connection**. The **Matrix Connection** dialog is displayed.

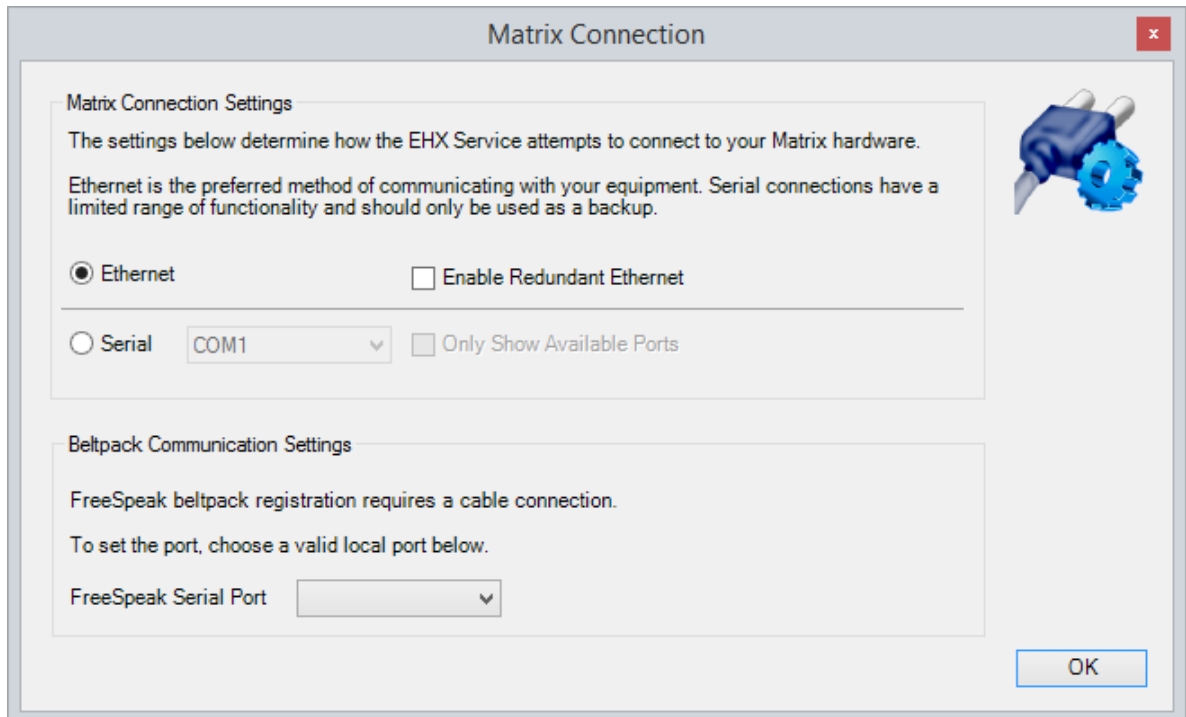

Figure 3-15 Matrix Connection

Ethernet connection is the default.

- 2) Select the **Serial** radio button.
- 3) From the drop-down menu, select the **COM port** on the PC the serial cable is connected to.

Note: Click **Only Show Available Ports** to display the available COM ports on the computer.

- 4) Select **OK**.

Note: When using a serial connection, the left-hand menu pane is highlighted in purple.

3.5 Adding a new matrix

When a new project has been created, matrices can be added to the project. There are two ways to set up a new matrix:

- Adding an offline matrix
- Adding a discovered matrix

Note: Matrices that are added to a project are allocated the next available system number at the time that they are added to the project.

3.5.1 Adding an offline matrix

If the matrix you want to configure is unavailable (for example, the matrix has yet to be installed), you can still add that matrix to the EHX project.

To add an offline matrix:

- 1) Right click the right-hand System pane.
- 2) Click **Add Matrix**. A matrix, with generic information, is added to the layout pane.

Note: An offline matrix is always displayed gray on the layout pane.

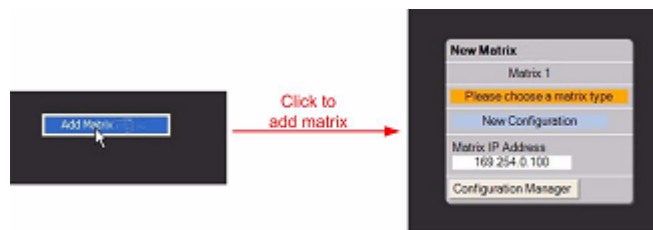

Figure 3-16 Adding an offline matrix (shell)

- 3) You can now configure the offline matrix with the relevant, specific configuration information (if known).

Configuring an offline matrix

The offline matrix, which is a shell at this stage, requires basic configuration, before you can start adding cards and panels.

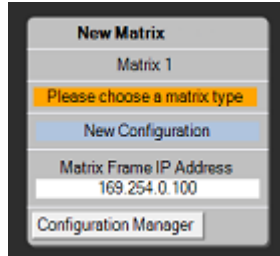

Figure 3-17 New Matrix Icon

To configure the matrix:

- 1) To enter a name for the matrix (optional), click **New Matrix** at the top of the matrix, and then enter a name.
- 2) To set the matrix type, click **Please choose a matrix type** on the matrix. From the drop-down menu, select the appropriate matrix type (Eclipse HX-Omega, Eclipse HX-Median, Eclipse HX-Delta or Eclipse HX-PiCo).

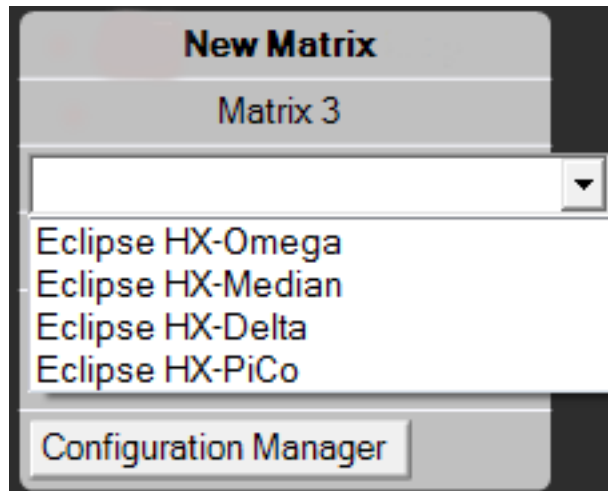

Figure 3-18 Select Matrix Type

- 3) The **Hardware** and **Configuration** menus for the matrix are now available from the sidebar menu for the matrix on the left of the screen. Click to open / view all menu options.

Note: The **Configuration** menu flashes amber, because there is no connection with physical hardware.

- 4) The default IP address (169.254.0.100) is shown on the matrix on the layout pane. Type the IP address of the offline matrix into the IP address field, if known.

3.5.2 Adding a discovered matrix

A matrix can only be discovered if:

- The Ethernet address of the matrix is accessible to the EHX PC.
- The EHX PC can receive broadcast packets from the matrix.

For more information, see section **3.4.1 Ethernet connection**.

To add a discovered matrix to the project:

- 1) Select **System > Layout**. If there are active matrices on the network, EHX lists the discovered matrices left of center on the screen.

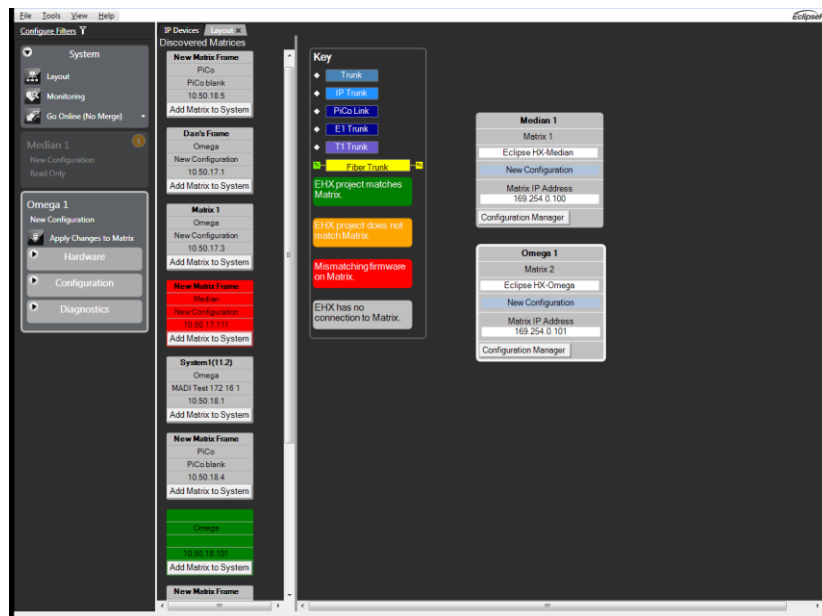

Figure 3-19 Layout Screen

- 2) To add a matrix to the new project, either:
 - Drag a discovered matrix into the right-hand pane (recommended). The matrix is added to the project and the **Hardware**, **Configuration** and **Diagnostic** menu links are displayed in the left-hand menu pane.
 - Click **Add Matrix to System** on the matrix icon. A dialog is displayed with the following options:

Option	Description
Empty Configuration	<p>If this option is selected the matrix is added and the Hardware, Configuration and Diagnostic menu links are displayed in the menu pane. The Hardware link flashes amber if no cards or panels have been configured.</p> <p>The matrix IP address and system preferences are set up as described below, after which the hardware should be configured manually.</p>
Discover Hardware	<p>Select this option to fully and automatically populate the project with available cards and panels.</p> <p>A progress bar is displayed while the hardware is being discovered (see below). The matrix is added to the project and the Hardware, Configuration and Diagnostic menu links are displayed in the left-hand menu pane.</p>
Retrieve map from Matrix	<p>This option is a backup facility that enables you to retrieve the last applied configuration from the matrix (provided one has been retrieved).</p> <p>Once the configuration has been loaded the Hardware, Configuration and Diagnostics menu links are displayed and the configuration (which already contains the system and panel setups) can be edited. This is not possible if the matrix CPU and EHX software are incompatible.</p>

Table 3-2 Add Matrix to Project Dialog

4 Using the EHX menus

This chapter gives a brief overview of the different sections of the EHX Software configuration screen. It also briefly lists and describes the main menu commands and options, with references to more detailed information.

4.1 Eclipse HX configuration software (EHX)

The Eclipse HX configuration software (EHX) controls the operation of the system’s connected audio devices, using a configuration (sometimes called a configuration map) that is applied to the matrix.

A matrix and connected devices operate in a star configuration, with each device connecting back to the matrix directly. Audio signals are routed through the central matrix and out to the connected audio devices in accordance with the configuration created in EHX.

EHX can also be used to monitor the matrix for faults and to log errors for analysis.

The EHX software comprises a graphical user interface with a main screen that is divided into two parts:

- The Menu pane – This is located on the left of the EHX main screen. It contains the System, Hardware, Configuration and Diagnostics dropdown menu lists.
- The System pane – This is located on the right of the EHX main screen. It contains a graphical representation items selected from the Menu pane.

Various menu items may be highlighted **amber** to indicate possible configuration issues:

Menu	Highlighted when ...
System	There is an open project, but not an open configuration. There is an open configuration but the matrix type is not set. There are multiple matrices in the system but the fiber ring is judged to be incorrect.
Cards and Ports	There are no ports configured for a matrix.
IP Devices	There are IP cards which do not have any available ports
Beltpacks	There are antennas but no beltpacks
Panels	There are key groups which do not have members There are configured panels but no configured keys
Controls	There are speed dials but no controls.

Table 4-1 Highlighted configuration issues

4.1.1 Layout and monitoring key

The layout and monitoring key gives status information about:

- Trunks
- Matrix firmware
- EHX to matrix connection
- EHX to matrix configuration matching

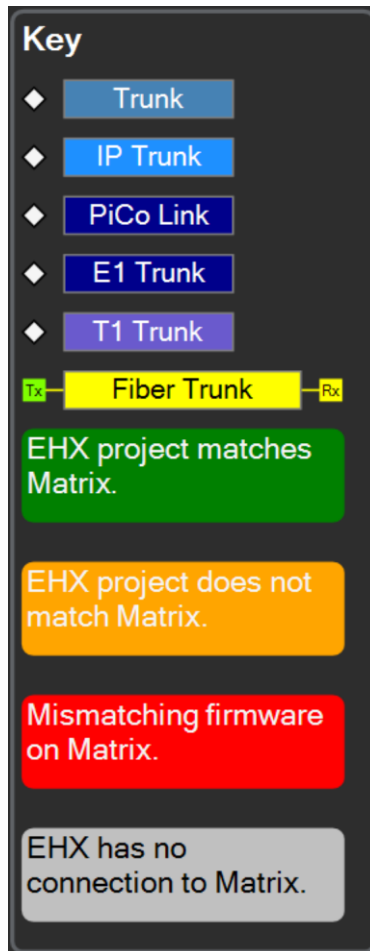

Figure 4-1 Layout and monitoring key

It is located in the System pane. To view the key, select **View > Display Layout and Monitoring Key**.

Status LEDs also appear next to the Matrix Name in the side bar. The Top LED replicates the colour shown in the layout screen. The Bottom LED replicates the colour in the monitoring screen.

In this instance the matrix has non-matching map and missing or errored hardware.

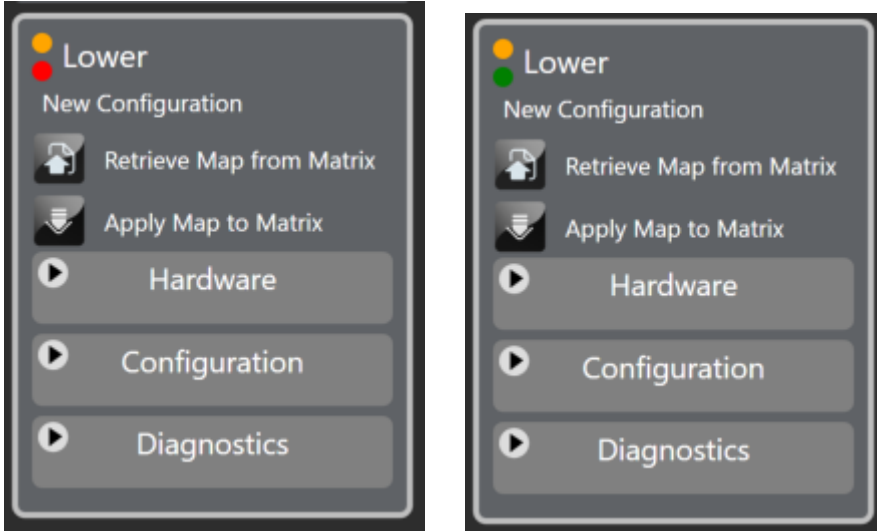

Figure 4-2 Status LEDs

4.2 Top menu

The Top menu contains the following drop-down lists:

- File
- Tools
- View
- Help

4.2.1 File menu

Use this menu to:

- Create, open, save and close project files (configuration maps).
- Import and export keysets
- Access the User Management facility
- Log out of, or exit EHX.

For more information, see section **5 Managing configurations and users**.

4.2.2 Tools menu

Use this menu to:

- Open the last logged-in project on starting EHX
- Enable retrieving configurations from a connected matrix

- Enable ten character labels. See section **6.8 Label**.
- Specify configuration banks
- Specify matrix connection (serial or Ethernet). See section **3.4 Selecting Ethernet or serial connection**.
- Load wireless beltpack or antenna (transceiver) firmware by USB connection. See section **20.2.17 Upgrading beltpack and antenna firmware**.
- Load firmware to matrices
- Apply EHX configuration changes to matrices. See section **7 Applying Eclipse HX**.

Tip: You can also press Ctrl + D to apply configuration changes.

4.2.3 View menu

Use this menu to:

- Browse back and forwards between the current screen and the previously viewed screen.

Tip: You can also press Alt + Left arrow and Alt + Right arrow.

- Display the Layout and Monitoring Key. See section **4.1.1 Layout and monitoring key**.

4.2.4 Help menu

Use this menu to:

- Open a PDF file of the EHX Software User Guide

Tip: You can press F1 at any time to open a PDF of the User Guide

- Clear unused memory. See section **27.8 Clear unused memory**.
- Save diagnostics. See section **27.7 Save diagnostics information utility**.

Note: You can also save diagnostics by right-clicking on a matrix and selecting **Save Diagnostics**.

- View release and version information about the software. See section **2.4.3 Identifying the EHX version**.

4.3 System menu

The System menu consists of the following items:

- Layout
- Monitoring
- Dynam-EC
- Go Live
- Apply Changes to all Matrices (when more than one matrix present)

4.3.1 Layout

This displays the System pane where you can view and configure matrices.

4.3.2 Monitoring

This displays the monitoring screen. For more information, see section **27.4 System monitoring**.

4.3.3 Dynam-EC

This opens the Dynam-EC application. For more information, see the *Dynam-EC User Guide*.

4.3.4 Go live

This enables live mode. Choose between:

- Go Live (No Merge)
- Go Live (EHX To System)
- Go Live (System To EHX)
- Go Live (Visual Merge)

For more information, see section **24 Go Live mode**.

4.4 Hardware menu

The Hardware menu consists of the following items:

- Cards and Ports
- IP Devices
- Beltpacks
- Transceivers
- GPOs
- GPIs

4.4.1 Cards and Ports

This displays the Cards and Ports screen, where you can add, remove and configure matrix cards.

4.4.2 IP Devices

This displays the IP Devices screen. For more information, see section **22 IP devices**. This is only visible when an IVC-32 card is present.

4.4.3 Beltpacks

This displays the Beltpacks screen. For more information, see section **20.1.1 Beltpack properties**. This is only visible when an E-Que card is present.

4.4.4 Transceivers

This displays the FreeSpeak II transceivers that are connected to your system.

4.4.5 GPOs

This displays the GPO screen. For more information, see section **16 General Purpose Inputs and Outputs**.

4.4.6 GPIs

This displays the GPI screen. For more information, see section **16 General Purpose Inputs and Outputs**.

4.5 Configuration menu

The Configuration menu consists of the following items:

Panels	Routes
Partylines	Speed Dials
Fixed Groups	Beltpack Roles
Local Advanced	Key Groups
IFBS	Logic
Controls	Preferences
Sort Groups	

4.5.1 Panels

This displays the Panel programming screen. For more information, see section **17 Panel programming**.

4.5.2 Partylines

This displays the Partyline configuration screen. For more information, see section **18.1 Partylines**.

4.5.3 Fixed Groups

This displays the Fixed Groups configuration screen. For more information, see section **18.2 Fixed groups**.

4.5.4 Local Advanced

This displays the Local Advanced screen. For more information, see section **17.15 Local advanced**.

4.5.5 IFBs

This displays the IFB configuration screen. For more information, see section **19 Virtual Interruptible Foldbacks**.

4.5.6 Controls

This displays the Controls configuration screen. For more information, see section **18.3 Controls**.

4.5.7 Sort Groups

This display the Sort Groups configuration screen. For more information, see section **18.4 Sort groups**.

4.5.8 Routes

This displays the Routes configuration screen. For more information, see section **18.5 Routes**.

4.5.9 Speed Dials

This displays the Speed Dials configuration screen. For more information, see section **18.6 Speed dials**.

4.5.10 Beltpack Roles

This display the Beltpack Roles configuration screen. For more information, see section **20.2.4 Beltpack roles and properties**. This is only visible when an E-Que card is present.

4.5.11 Key Groups

This displays the Key Groups configuration screen. For more information, see **18.7 Key groups**.

4.5.12 Logic

This opens the Logic application. For more information, see the *Logic Programming User Guide*.

4.5.13 Preferences

This displays the Preferences screen. Here, you can set preferences for the following:

Preference	For more information ...
Intelligent Linking	25.2.2 Intelligent linking preferences
ISO and IFB	19.1 ISO and IFB preferences
System Access Codes	5.13 System Access Codes
Wireless Beltpacks	20.2.18 Wireless beltpack preferences
Key Operation	17.5 Key operation preferences
Panel Operation	17.4 Panel programming preferences
IP Panels	22.2 IP panel preferences
Dynam-EC	17.16.7 Dynam-EC preferences
Configuration Download	7.5 Configuration application preferences

Table 4-2 Preferences menu

4.6 Diagnostics menu

The Diagnostics menu consists of the following items:

Menu item	For more information
Crosspoint Map	27.1 Crosspoint map
Event Log	27.2 Matrix event log
Wireless Status	
Resource Chart	27.6 Resource chart

Table 4-3 Diagnostics menu

4.7 System pane menus

The menus described in this section are accessed either by:

- Right-clicking in an empty area of the System pane
- Right-clicking a matrix that is in the System pane

4.7.1 Right-clicking in an empty area of the System pane

The following items appear:

- Add Matrix – use this to add a new matrix to the System pane
- Restore Matrix Locations – use this to restore the original matrix positions in the System pane after you have relocated them
- Zoom – use this to adjust the magnification of the System pane view. You can choose between:
 - Zoom To Fit – this adjust the System pane magnification so that all matrices are visible
 - Zoom to 50, 75, 100, 125 or 150 per cent

4.7.2 Right-clicking a matrix

The following items appear:

Apply Map to Matrix	Show Matrix's Redundant IP Address
Configuration	Delete Matrix From Project
Firmware	Filter Matrix
User Access Control	Save Diagnostics
Change IP Settings	

Apply Map to Matrix

Use this to apply configuration changes to the matrix.

Tip: You can also select **Tools > Apply Changes To Matrix** or from the Menu pane, select **Apply Map to Matrix** or press **Ctrl + D**

Configuration

This opens the configuration drop-down list. For more information, see section **5.15 Configuration options**.

Firmware

This opens the Firmware drop-down list. For more information, see section **5.15.5 Firmware options**.

4.7.3 User Access Control

Use this to specify who can access each matrix. For more information, see section **5.15.6 User access control**.

4.7.4 Change IP Settings

Use this to view and edit the matrix IP settings. For more information, see section **5.15.7 Change IP settings**.

4.7.5 Show Matrix's Redundant IP Address

Use this to display the redundant IP address of the matrix under the IP address. For more information, see section **5.15.8 Show matrix redundant IP address**.

4.7.6 Delete Matrix From Project

Use this to completely remove the matrix from your configuration.

4.7.7 Filter Matrix

If you have many matrices in your configuration, you can use this to determine which ones are visible in the System pane. For more information, see section **5.15.10 Matrix filtering**.

Tip: You can also use **Configure Filters** at the top of the Menu pane.

4.7.8 Save Diagnostics

Use this to take a snapshot of the current state of your configuration, the EHX PC and the matrices, and store it as a compressed file on your computer.

This information can then be sent to Clear-Com support to assist with diagnosis.

For more information, see section **27.7 Save diagnostics information utility**.

Note: You can also save diagnostics from **Help > Save Diagnostics**.

4.8 Keyboard shortcuts

The table below lists the keyboard shortcuts that you can use instead of menus.

Menu	Function	Shortcut
File	New Project	Ctrl + N
	Open Project	Ctrl + O
	Close Project	Ctrl + F4
	Save Project	Ctrl + S
Tools	Apply Changes To Matrix	Ctrl + D
View	Back (move back a screen)	Alt + left arrow key
	Forward (move forward a screen)	Alt + right arrow key
Help	Display help PDF file	F1

Table 4-4 Keyboard shortcuts

5 Managing configurations and users

5.1 Introduction

Use the **File** menu to create, open and save projects.

You can also delete projects and export projects as *.hxn files so that you can import them back into EHX later.

5.2 Creating a project file

A project (stored and exported as an *.hxn file) provides a container for your configurations, and might consist of one or many configurations for one or many matrices.

A project can be used to define every aspect of a complex intercom system, including the connectivity between multiple, intelligently linked matrices and/or the configurations for individual matrices. An unlimited number of projects may be stored on the hard drive of the EHX PC or on a server.

A configuration determines the operating parameters of the Eclipse HX system.

When you first create a configuration, the file does not have any content. EHX populates the configuration with details of the system, including:

- The user panels, interface cards, interface modules and control devices associated with the matrix / matrices.
- The labels (alphanumeric names) assigned to each device.

To create a project file:

- 1) Select **File > New Project** (Control-N).

Note: Control-N can be used when in any EHX mode to start a new configuration map.

- 2) If you are running EHX in Client-Server mode, enter a name for the project in the dialog. Click **Save**.

The project name is displayed on the title bar at the top of the screen.

5.3 Opening a project

- 1) To open a project, select **File > Open Project** (Control-O)
In Client-Only mode, a standard Windows Open dialog is displayed.

In Client-Server mode, a dialog is displayed with a list of available projects. Select the project and click **Open**.

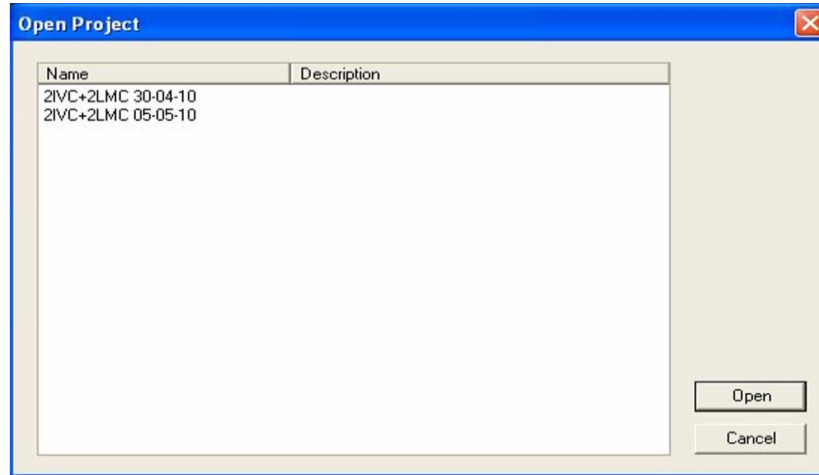

Figure 5-1 Client-Server mode: Project list dialog

- 2) Navigate to the project file and click **Open**.

Note: A list of recently opened files is also available from the **File** menu. Select **File > Recent Projects**.

Note: To automatically open the last configuration on starting EHX, enable **Tools > Open Last Project On Login**.

Note: If a project is already open, EHX asks if the current project should be saved before opening the new project.

5.4 Password protection override

EHX users with Network Admin rights can open any configuration within a project, even if a configuration password has been set in the Configuration Manager. Users with Network Admin rights can also reset the password if required.

If an EHX user without Network Admin rights tries to open a password protected configuration within a project, they must enter the correct password.

5.5 Closing a project

To close a project, select **File > Close Project** (Control-F4).

Note: If there are unsaved changes, EHX prompts you to save the project before closing.

5.6 Importing and exporting a project

In Client-Only mode, importing a project will open a normal windows dialogue screen. Navigate to the file location and select the project.

- 1) In Client-Server mode, to import a project / configuration (*.ccn or *.hxn file format) into EHX select **File > Import Project**.
- 2) Navigate to the project file you want to import. Select the file and click **Open**.
The project is then displayed in the normal project selection screen and you can select and load the required project, as described previously (see above).

Note: After a project file is imported from a previous version of EHX, it is advisable to ensure that the matrix type is set correctly.

If the imported configuration is currently active on the matrix, and has not been renamed, Clear-Com recommends applying the imported configuration to the matrix before entering Go Live mode.

- 3) You can export a project (*.hxn file format only) from EHX by selecting **File > Export Project**.
- 4) Navigate to the desired folder location. Name the file and click **Save**.

5.7 Saving a project

To save the project, select **File > Save Project** (Ctrl-S).

5.7.1 Save project as

- 1) To change the name or details of a configuration you want to save, select **File > Save Project As**.
- 2) In Client-Only mode, a standard **Windows Save As dialog** is displayed. Enter a project name and click **Save**.
- 3) In Client-Server mode, the **Save Project dialog** is displayed. Change the name and/ or description of the project and then click **Save**.

Note: Client-Server mode only: **Save** saves changes to the EHX database but does not apply the configuration to the Eclipse HX matrix.

5.7.2 Save Dynam-EC information

You can save a file that holds the project information required for Dynam-EC to link to frames in the project.

- 1) Select **File > Save Dynam-EC Information**.

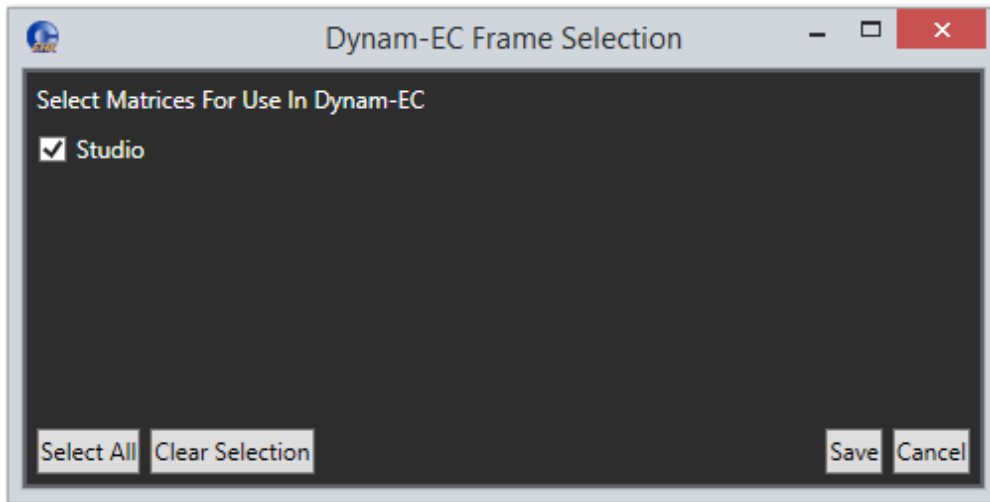

Figure 5-2 Dynam-EC Information

- 2) Select the required matrix or matrices.

Note: To select all the matrices in the configuration, click **Select All**.

5.8 Deleting a project

In Client-Only mode, you can delete project files directly from the PC.

To delete a project:

- 1) In Client-Server mode, select **File > Delete Project**.
- 2) The delete project screen is displayed. Select the project to be deleted and click **Delete**.
- 3) A confirmation dialog is displayed. To continue with the deletion, click **Yes**.

5.9 Importing/exporting configuration keysets

You can use the **Import/Export Configuration Keysets** wizard (**File > Import/Export Configuration Keysets**) to:

- Export all the keysets in the current configuration to an external file.
- Import all the keysets from an external file and apply those keysets to the current configuration. Saved configuration keysets can be imported into other configurations avoiding the need to manually recreate panel setups.

5.9.1 Importing configuration keysets

To import configuration keysets:

- 1) Select **File > Import/Export Configuration Keysets**.
- 2) The welcome screen of the wizard is displayed. Select **Import keysets**.

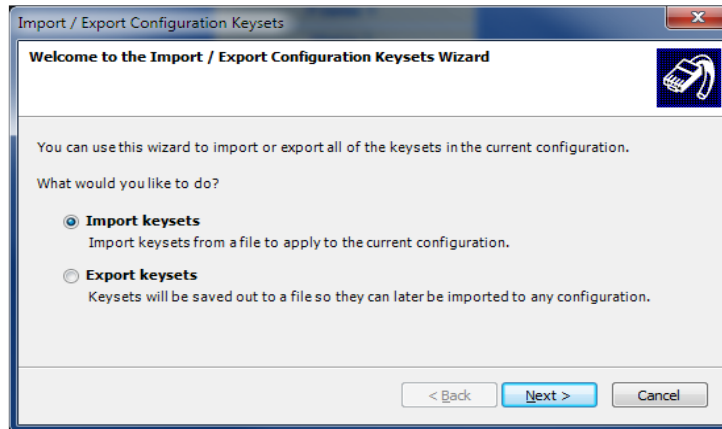

Figure 5-3 Import and Export Configuration Keysets Dialog

- 3) Click **Next**.
- 4) Click **Browse...** to navigate to the keyset file you want to import. To load the file into the dialog, select the file and click **Open**.

Note: The default file extension for the keyset files is ***.KEYSET**.

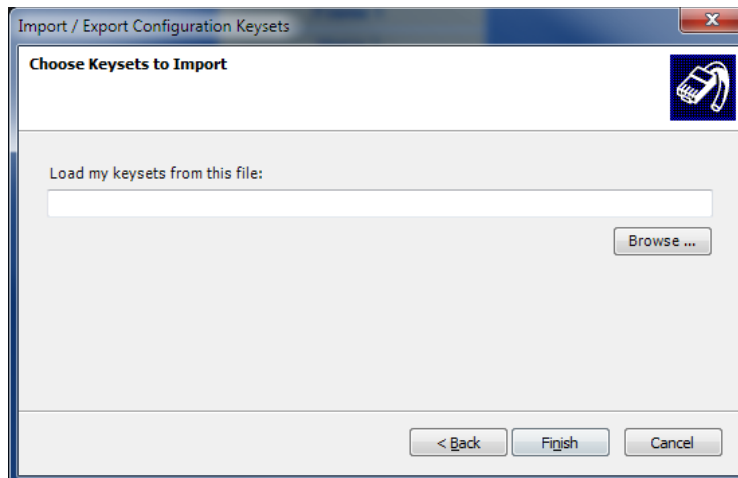

Figure 5-4 Import Keyset File Dialog

- 5) To import the keysets into the current configuration, click **Finish**.

5.9.2 Exporting configuration keysets

To export configuration keysets:

- 1) Select **File > Import/Export Configuration Keysets**.
- 2) The welcome screen of the wizard is displayed. Select **Export keysets**.
- 3) Click **Browse...** to select a folder to save the file to. Enter the required filename.

Note: The default file extension for the keyset files is *.KEYSET.

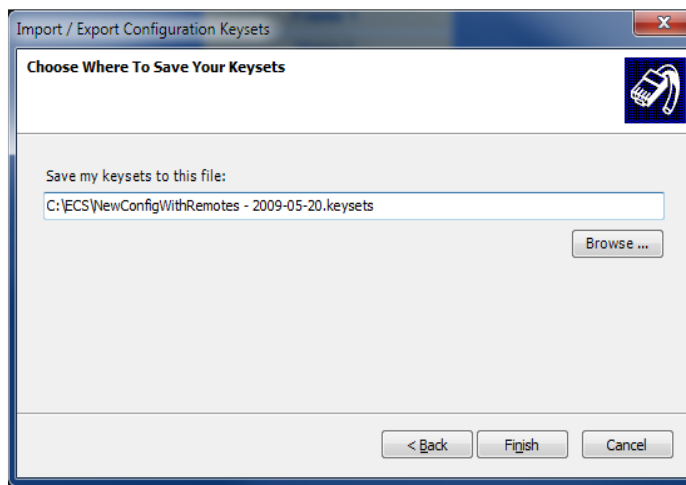

Figure 5-5 Exporting Configuration Keysets

- 4) To export the keyset configurations, click **Finish**.

5.10 User management

- 1) To access the user management facility, select **File > User Management**.

Note: Only EHX users with network administrator rights (Network Admin) can access the user management facility.

The user management facility provides the tools necessary to administer EHX users and control the level of system access. It is possible to:

- Add or delete users
- Change passwords
- Assign access levels or roles

Currently EHX has four access levels:

- Network Admin
- Local Admin
- User
- Guest

Note: Guest user access is allowed on a matrix even if another user is already logged in. This means, for example, that a local admin can have exclusive write access to a matrix, while at the same time one or more guest users can also be logged in to the same matrix to perform online key changes

Note: EHX remembers the last used login. If you are not required to save the login, deselect the Save option in the dialog. EHX displays the name and role of the current user on the title bar of the EHX window.

5.10.1 Network admin access level

The network administrator role provides unrestricted access to all the configuration settings on all the systems in a linked set. Network administrator rights include:

- Configuration Management
- Configuration Allocation
- All configuration editing
- Digital Wireless setup
- IP Addressing
- Trunk Allocation
- User Management
- Live configuration
- Monitoring
- Live status under System
- Firmware update

5.10.2 Local-admin access level

The local administrator level provides unrestricted access to all configuration settings on the local system the user is logged in to. The network administrator can control which matrices the local administrator can access.

The local administrator has no access to user management and cannot change the configuration settings on other systems in a linked set using the layout pane, but can

view a linked set configuration. The local administrator can also view the live status of system components using the layout pane.

Local administrator rights include:

- Configuration Management
- Configuration Allocation
- All configuration editing
- Digital Wireless setup
- IP Addressing
- Live configuration
- Monitoring
- Live status under System
- Firmware update

5.10.3 User access level

The user level provides access to all configuration editing and downloading capability, including:

- Configuration Management
- Configuration Allocation
- All configuration editing
- Digital Wireless setup
- IP Addressing
- Live configuration

The user level has no access to user management or the layout pane and its associated functions.

5.10.4 Guest access level

The guest level provides a minimum level login and is the default role if the user is removed from all other groups.

The guest role only allows access to panel programming on the current system configuration.

The guest user can open more than one system configuration in a linked set but cannot modify any system parameters. The guest role does not allow access to user management.

Guest access to the matrix is allowed in parallel with other users.

The online additions to panel programming made via guest access are not stored in the EHX server configuration.

5.10.5 Managing user access levels

- 1) To access the user management facility, select **File > User Management**.

Note: Only EHX users with network administrator rights (Network Admin) can access the user management facility.

When EHX is initially installed a single network administrator account is preconfigured with the username Administrator. This account can then be used to set up other accounts as required.

When user management mode is entered, a complete list is shown of all the registered users. Users can be added, deleted and edited from this screen

Note: If the user is removed from all other groups, the user becomes a Guest user by default.

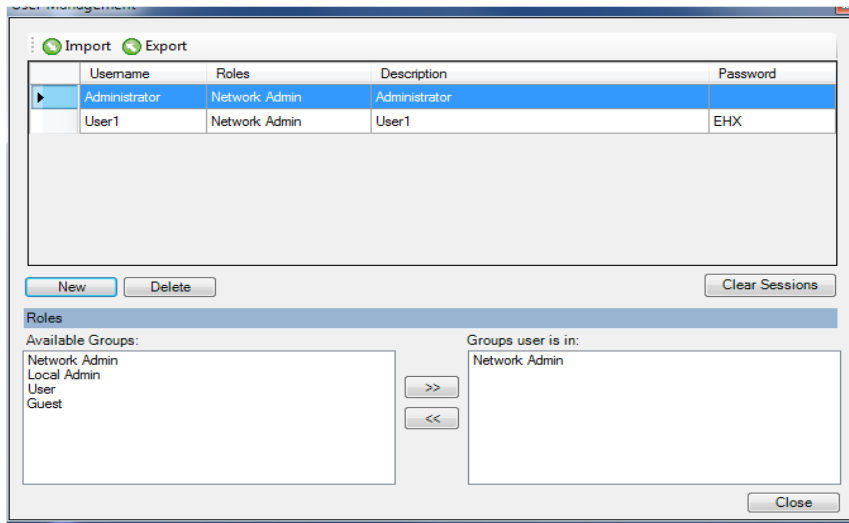

Figure 5-6 User Management screen

5.10.6 Creating a new EHX user

To create a new EHX user:

- 1) Select **File > User Management**.

Note: Only EHX users with network administrator rights (Network Admin) can access the user management facility.

- 2) The **User Management** screen is displayed. To add a new User ID, click **New**.

A new user is added. The default access level is Network Admin (see above).

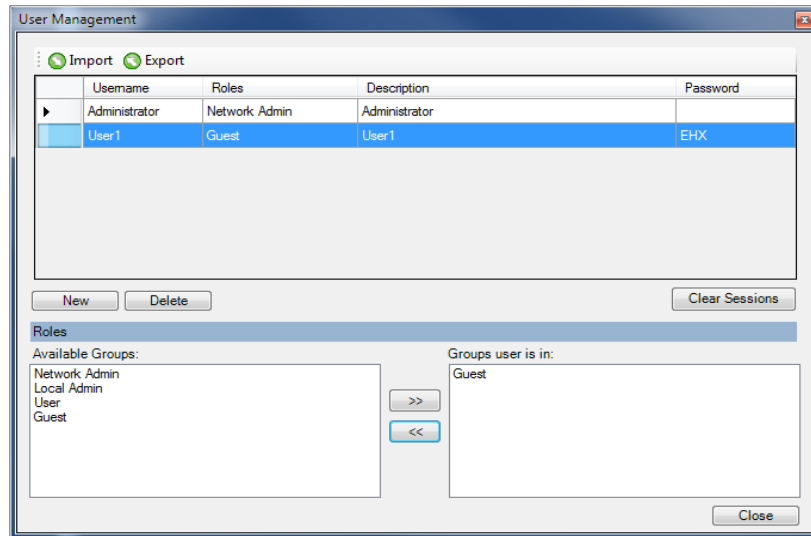

Figure 5-7 Creating a New User

- 3) Edit the **Username**, **Description**, and **Password** fields. Double click to highlight the entry.
- 4) To change the access level of the new user:
 - Go to the **Available Groups** pane.
 - Select either **Local Admin** or **User** and use the right arrow (>>) to transfer that role into Group user is in.

The previous access level is replaced by the new access level in the Group user is in pane.

- 5) When you have completed your changes, click **Close**.

5.10.7 Editing an existing EHX user

To edit a user:

- 1) Select **File > User Management**. The **User Management** screen is displayed.

Note: Only EHX users with network administrator rights (Network Admin) can access the user management facility.

- 2) Select the user you want to edit from the list. To modify the **Username**, **Password**, **Description** or access level groups the user belongs to, follow Steps 3 - 5 in **Creating a New EHX User** above.

- 3) When you have completed your changes, click **Close**.

5.10.8 Deleting a user

To delete a user:

- 1) Select **File > User Management**. The **User Management** screen is displayed.

Note: Only EHX users with network administrator rights (Network Admin) can access the user management facility.

Ensure that a network administrator is logged into EHX to access user management.

- 2) Select the user you want to delete and click **Delete**.

A confirmation prompt is displayed. To continue with the removal of the user, click **Yes**.

- 3) To exit the **User Management** screen, click **Close**.

Note: One valid network administrator account must always be available to allow login to EHX and to access User Management. You cannot delete either the default network administrator account or the currently logged in user account.

Note: If you delete a user from the **User Management** screen, the user will be highlighted in red in the **Access Control Screen** to indicate that the user previously had access permission. If you deselect the user, the user will no longer be visible in the **Access Control Screen**.

5.11 Logging in and out of EHX

From within the EHX software, you can log in from: **File > Log In**

The Log In window appears:

Figure 5-8 Log in

Select **Options** to log into a server:

The screenshot shows a dialog box titled "Login to EHX" with the Clear-Com logo at the top. Below the logo are three input fields: "User name:" containing "Administrator", "Password:" (empty), and "Log on to:" containing "http://localhost/EclipseServer/". To the right of the password field is a checked checkbox labeled "Save". At the bottom of the dialog are three buttons: "OK", "Cancel", and "Options <<".

Figure 5-9 Log in server

To log out of EHX, select **File > Log Out**. You will be prompted to save any changes.

5.12 Exiting EHX

To exit EHX, select **File > Exit**. You will be prompted to save any changes.

5.13 System Access Codes

You can protect aspects of system functionality with access codes. To enter codes to unlock features, select **Configuration > Preferences > System Access Codes**.

DTMF Passcodes

Passcode 1:

Passcode 2:

Passcode 3:

Passcode 4:

Passcode 5:

Passcode 6:

Passcode 7:

Passcode 8:

Menu Access Code (Panel and FreeSpeak II Beltpack)

Enter the code that users must enter to access PIN protected menus.

Code:

Features Passcode

License Dynam-EC, Agent IC and HCl by entering the 16 digit passcode obtained from your distributor below:

Figure 5-10 System Access Codes tab

Use the DTMF Passcodes section to set the global access codes within the Eclipse HX System. Eight DTMF codes are available for accessing the Eclipse HX System from a remote location (using DTMF Inward Access).

When you assign a value to any of the eight available DTMF codes, that code becomes recognizable to any MVX-A16 port in the Eclipse HX System.

Note: For Eclipse HX-PiCo, only ports 17 to 32 can be configured for DTMF access codes.

You can configure a TEL-14 module that is connected to a MVX-A16 port, or an LQ SIP client that is connected to a matrix port with a setting that tells the port to recognize any, all, or none of the configured DTMF access codes.

If any MVX-A16 or IVC-32 port has been configured to recognize one or more of the DTMF access codes, then that port allows any caller to access the system who correctly enters a recognized access code.

Note: Access codes are formed of numeric characters and must be four digits long. EHX does not allow a password field containing fewer than four characters, and only accepts numerals.

DTMF Passcodes

Passcode 1:	<input type="text" value="1234"/>
Passcode 2:	<input type="text" value="2341"/>
Passcode 3:	<input type="text" value="3412"/>
Passcode 4:	<input type="text" value="4123"/>
Passcode 5:	<input type="text"/>
Passcode 6:	<input type="text"/>
Passcode 7:	<input type="text"/>
Passcode 8:	<input type="text"/>

Figure 5-11 Example DTMF Passcodes

Menu access code

Some menus can be PIN protected. The PIN protected menus on V-Series panels are:

- Sys Config Access
- Local Pref Menu access
- Diagnostic Menu Access

For FreeSpeak II beltpacks, the **Admin Options** menu is protected.

Features Passcode

You can enter a 16-digit passcode to enable Dynam-EC and/or Agent-IC Mobile Client to operate with the matrix. You can also enable the HCI (Host Computer Interface) for third-party applications. This passcode is purchased / obtained from Clear-Com. For more information, see your Clear-Com representative.

Note: If the passcode is changed, an apply with reset is required to implement the change.

5.14 The EHX screen after a project has been loaded

When a project has been loaded for editing:

- The EHX menus are displayed on the left-hand side of the screen.
- The **Tools > Apply Map To Matrix** link is enabled.

The Diagnostics menu is only displayed if a valid system configuration is present.

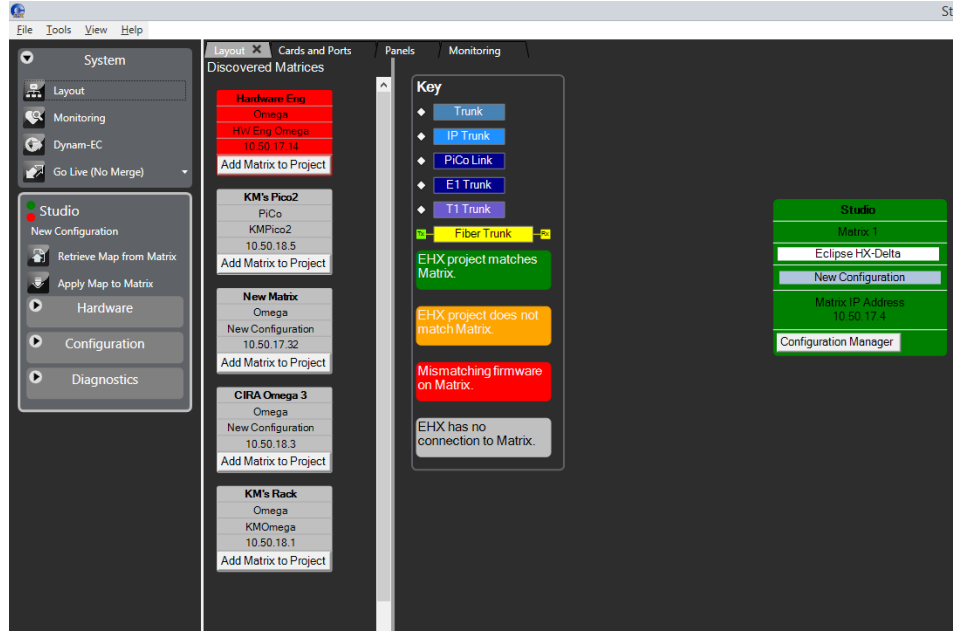

Figure 5-12 Menu Display with Projects Loaded

Note: The **Go Live** button enables EHX to enter Live mode. This enables some matrix configuration items (highlighted in green) to be modified interactively without needing to apply a new configuration. For more information, see section **24 Go Live mode**.

5.15 Configuration options

You can configure each matrix using the matrix menu configuration options. To access these, right-click the matrix icon, and select **Configuration**. The options and sub menus are:

- Configuration Manager
- Create a New Configuration
- Retrieve a Configuration from Matrix Frame
- Configuration Banks
- Backup Key Status
- Restore Key Status

5.15.1 Configuration Manager

Use the **Configuration Manager** to save, load, import and export configurations. You can also protect configurations through password protection. A configuration contains details of matrix hardware setup, ports and audio routing. It does not contain details of the matrix IP address.

- 1) In the **System** pane, right-click the matrix icon, and select **Configuration > Configuration Manager**. The following screen appears:

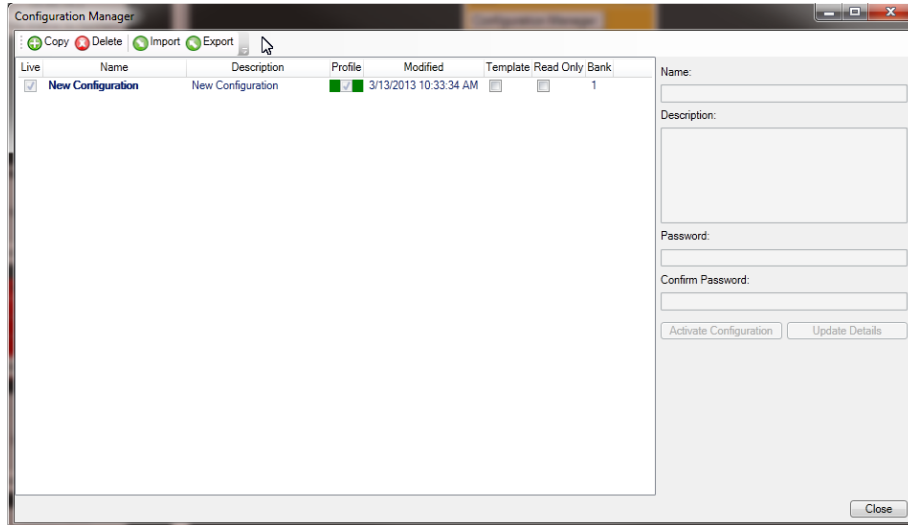

Figure 5-13 Configuration Manager Screen

- 2) Edit the name of the configuration map. You might also want to enter an optional description and configuration password.
- 3) Select the **Read Only** checkbox if this configuration is to be fixed as read-only.
- 4) Select the **Template** checkbox if this configuration is to be used as a basis for creating new configurations, by opening the configuration and saving it as a new project.

The **Profile** column is color-coded:

- Green indicates the configuration can be applied without a reset.
- Red indicates a black reset is required (clearing the matrix memory after applying a configuration). Such a reset may break trunk tables, and is undesirable in a multi-user multi matrix system.

The profile of a matrix describes how it interacts with other matrices in a linked system. This column indicates whether the selected configuration matches the existing matrix profile or whether it affects other matrices in the linked system.

- 5) Click **Update Details** to update the configuration map details without closing the **Configuration Manager** screen.
- 6) If multiple configurations are available (if configurations have been copied or imported), select the configuration you wish to use or edit, then press **Activate Configuration** to confirm.

5.15.2 Create new configuration

You can create a new configuration which may be empty or which contains only the hardware discovered from the matrix.

To create a new configuration:

- In the **System** pane, right-click the matrix icon, and select **Configuration > Create New Configuration**, and then select either **Discover Hardware** or **Empty**.
- Select **Configuration > Create New Configuration** and then either **Discover Hardware** or **Empty**.
- If you select **Discover Hardware**, a warning message appears before the current hardware configuration is replaced (see below). To continue, click **Yes**. EHX interrogates the matrix to obtain the current hardware configuration.

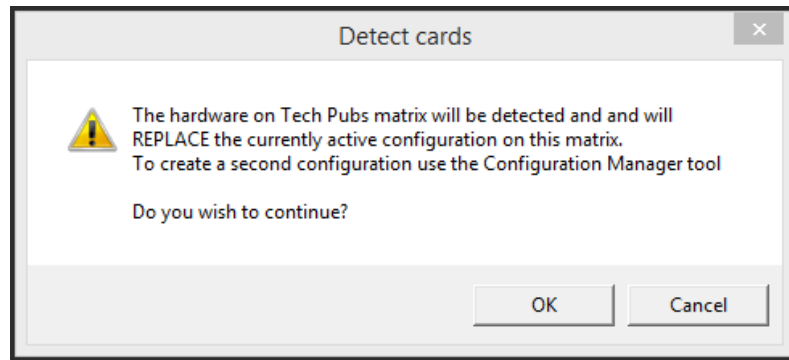

Figure 5-14 Discover Hardware Confirmation

- If you select **Empty**, the configuration is created with no hardware or configured devices.

5.15.3 Retrieve or apply configuration from matrix

You can retrieve or apply the last retrieved configuration, including labels, from the matrix. This option is a backup facility that enables you to retrieve the last applied configuration from the matrix (provided one has been loaded).

To retrieve the last applied configuration from the matrix, in the **System** pane, right-click the matrix icon, and select **Configuration > Retrieve Map from Matrix**. The following screen appears:

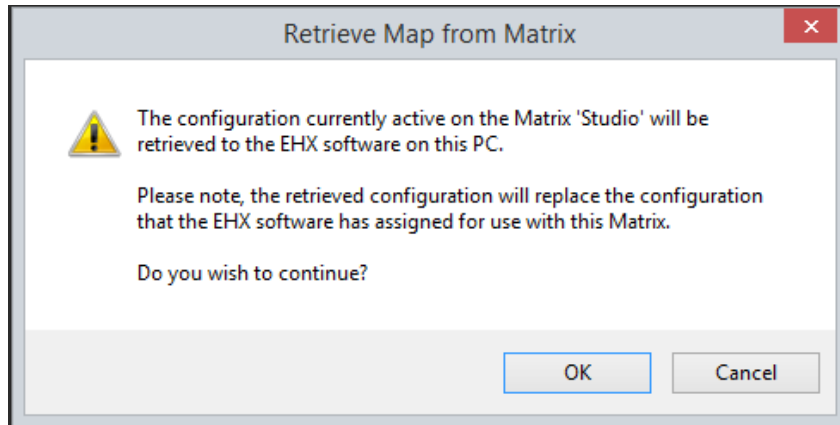

Figure 5-15 Retrieve map

The configuration uploads to EHX from the matrix.

Note: When you retrieve a configuration, it will overwrite any currently active configuration. This also applies to NEW EMPTY configuration and NEW DETECTED configuration. In all three cases, the current configuration is removed and replaced with what you have requested.

Note: Retrieving the configuration will NOT upload any Intelligent Link connections that were previously defined on the Layout Screen.

5.15.4 Back up key status

Use this option to upload and store a record of all panel talk and listen key states on the EHX matrix.

This function also saves the states of the panel microphones, panel headsets and panel loudspeakers. For example, you could use this facility to record the state of talk and listen keys prior to an **Apply changes with reset and clear all memory** of the matrix or as a known state prior to a production.

In the **System** pane, right-click the matrix icon, and select **Configuration > Back up Key Status**.

This function is used in conjunction with the **Restore Key Status** function (see below).

Restore key status

Use this option to download a previously saved record of the state of talk and listen keys to the matrix to restore the talk and listen keys to their previous states.

This function also restores the states of the panel microphones, panel headsets and panel loudspeakers.

In the **System** pane, right-click the matrix icon, and select **Configuration > Restore Key Status**.

This function is used in conjunction with the **Back up Key Status** function (see above).

5.15.5 Firmware options

Use the Firmware options to:

- Update firmware on this matrix.
- Request a firmware report that contains the details of all the firmware versions on the matrix cards and attached panels which support the function.

Note: You can also update the firmware from the **Tools** menu, by selecting **Apply Firmware To Matrices**.

To display a firmware report, in the **System** pane, right-click the matrix icon, and select **Firmware > Firmware Report**. The firmware report consists of a System Versions Summary and a Detailed Firmware Version Listing.

The firmware versions are listed in a text window and can be exported to a *.csv file. This file type is usually opened by spreadsheet programs, such as Excel. An example of a firmware report is shown in **Figure 5-16**.

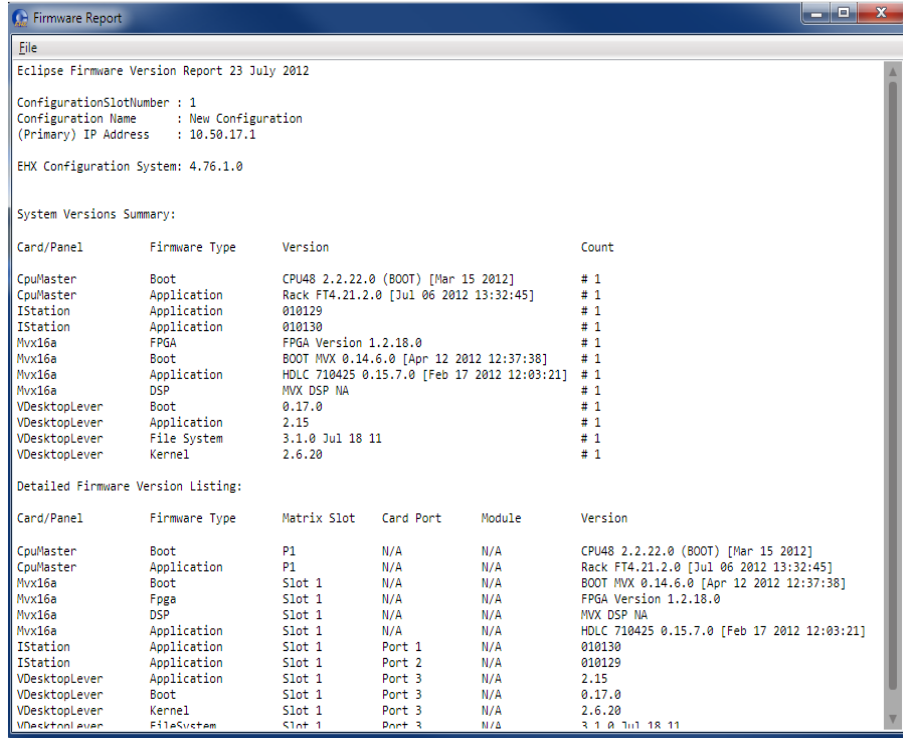

Figure 5-16 Firmware Report Display

The report provides a summary of the firmware versions, followed by a detailed list for all devices that provide this information.

Device	Firmware information listed
CPU card	CPU cards list the boot PROM version, the application version, the versions of the CPLDs and the current settings of the DIP switches.
MVX-A16 card	MVX-A16 cards list the application version and HDLC version.
Fiber card	Fiber cards list the FPGA version.
E-QUE, IVC-32, LMC-64 cards	Cards list the boot code version, the FPGA version and the application version.
E-MADI64-HX	E-MADI cards list the boot code version, the FPGA version, the DSP version, and the application version.
E-DANTE64-HX card	App, Boot, DSP and FPGA versions. Also, a combined Dante module file, .dnt extension.
E-IPA-HX card	App, boot and FPGA.
V-Series panel	V-Series main panels list the boot code version, the application version, panel kernel version and the file system version. V-Series expansion panels only list boot and application versions.
i-Series panel	i-Series panels report the application version.
ICS-1008/16 panel	ICS-1008/16 panels report the application version.
ICS-22 panel	ICS-22 panels report the application version.
FreeSpeak Transceiver/antennas	App, boot, hardware version.
Online FreeSpeak II beltpacks (since the last black reset)	App, boot, hardware version, role.

Table 5-1 Firmware Report Information

5.15.6 User access control

Each matrix in a project can be protected from access by unauthorized user accounts. This is controlled using tick boxes listing the available users, and whether they are permitted to change the selected matrix. You can choose between access to the matrix for:

- Everyone
- Administrator

- Selected user

5.15.7 Change IP settings

You can use this feature to change the matrix IP settings. The following screen appears:

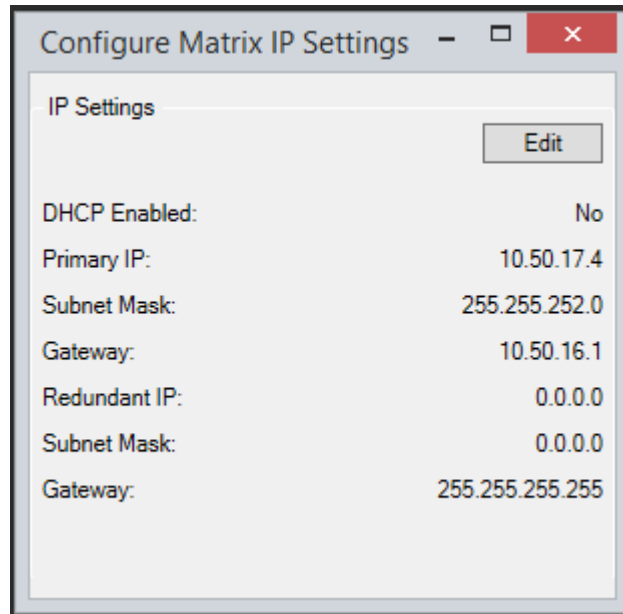

Figure 5-17 Configure Matrix IP Settings

Click **Edit** to change the settings.

5.15.8 Show matrix redundant IP address

You can use this feature to display the matrix redundant IP address.

5.15.9 Delete matrix from project

You can remove matrices from the project using the right click menu.

- 1) In the **System** pane, right-click the matrix icon, and select **Delete Matrix from Project**. The following warning appears:

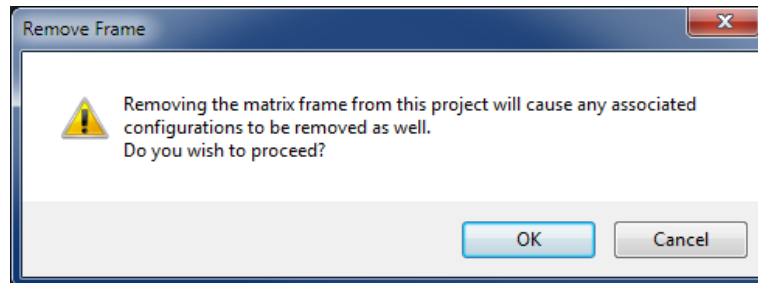

Figure 5-18 Matrix Delete Confirmation

- 2) To continue, click **OK**.

When the operation is complete, the matrix icon is deleted from the System pane.

5.15.10 Matrix filtering

If there are many matrices in a project, it is possible to select which matrices are visible and configurable in the Palette. If there is more than one matrix in the project, the **Configure Filters** button is visible in the top left of the screen.

- 1) Select **Configure Filters**, the following screen appears.

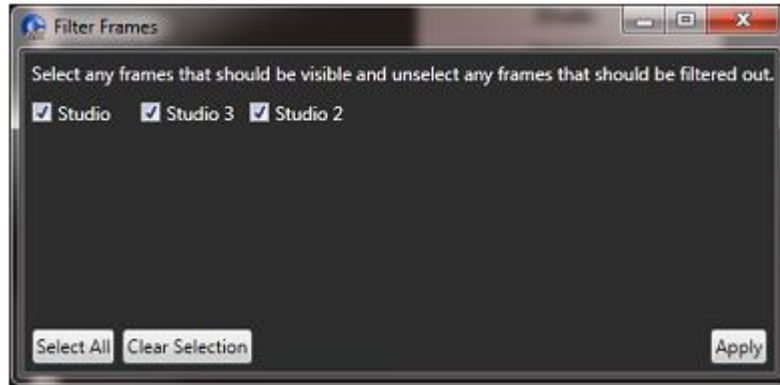

Figure 5-19 Filter Matrices

- 2) Deselect any matrices that you do not wish to be visible in the Palette.

Note: You can also place the cursor over the matrix icon, right-click and then select to filter or unfilter a matrix.

- 3) Select **Apply**. You return to the Palette.

Note: Deselecting a matrix does not remove it from the project.

Note: Entities from filtered out matrices do not show on screens for non-filtered frames. For example, if you filter matrix 2, then go to, say the fixed groups screen on matrix 1, you do not see any entities from matrix 2. This is only true for entities that are available to be assigned - you always see already assigned entities (existing group members) whether they are filtered or not. In addition, panel programming maintains a separate list of filters.

6 Configuring hardware

This chapter describes the general procedure for configuring hardware. For specific information about configuration cards, see the relevant chapter.

6.1 Matrix hardware setup

To begin configuring the matrix hardware, go to **Hardware > Cards and Ports**.

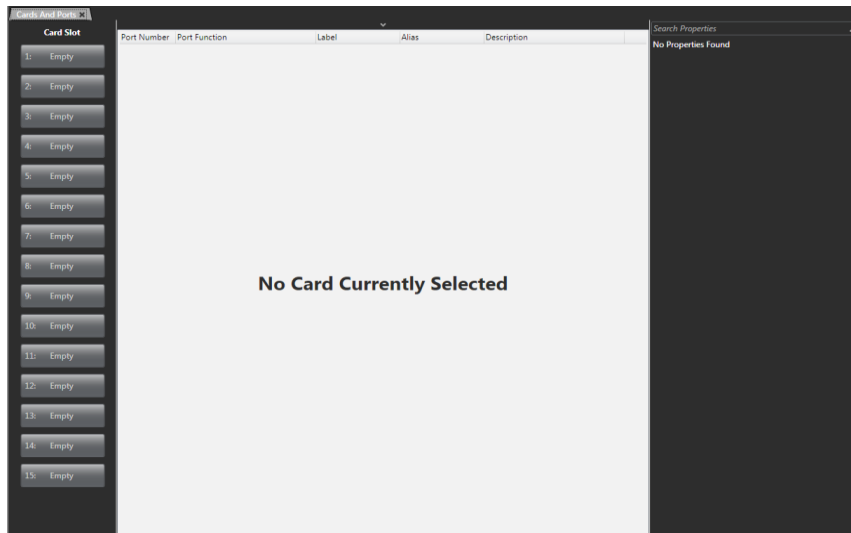

Figure 6-1 Initial Matrix Hardware Screen (HX Omega)

If the matrix is available on the network (the correct firmware has been loaded and the IP address has been set up), the hardware can be auto-detected by clicking **Detect New Hardware** at the top of the screen.

Note: **Detect New Hardware** is only visible if the **Port List Options** drop down list at the top of the screen is active.

From the Cards and Ports screen, you can add cards to the available slots on the matrix. You can choose between the following cards:

- MVX-A16 cards – used mainly to connect intercom panels and interface cards and four-wire devices to the matrix
- E-Que cards – used to connect wireless intercom systems such as FreeSpeak, CellCom and FreeSpeak II and for E1/T1 connection between matrices.
- E-IPA-HX cards – used to connect both IVC ports and FSII IP transceiver (IPT) support. This can be a combination of up to 64 IP ports or FreeSpeak II wireless beltpack connections (according to license).

- IVC-32 cards – used to connect IP-enabled V-Series panels, Concert, Agent-IC Mobile Clients and LQ Series devices.
- LMC-64 cards – used to allow audio level metering data to Dynam-EC clients over an IP network.
- E-FIB cards – used to provide fiber trunking between matrices.
- E-MADI cards – used to provide up to 64 duplex MADI channels used to connect V-Series panels.
- E-DANTE cards – used to provide up to 64 channels of audio networking using Dante/AES67 network protocols and software, so that you can transport many channels of high quality audio via a Clear-Com matrix to multiple Dante/AES67 enabled devices.

Note: When you add or remove a card in your configuration, the following message appears:

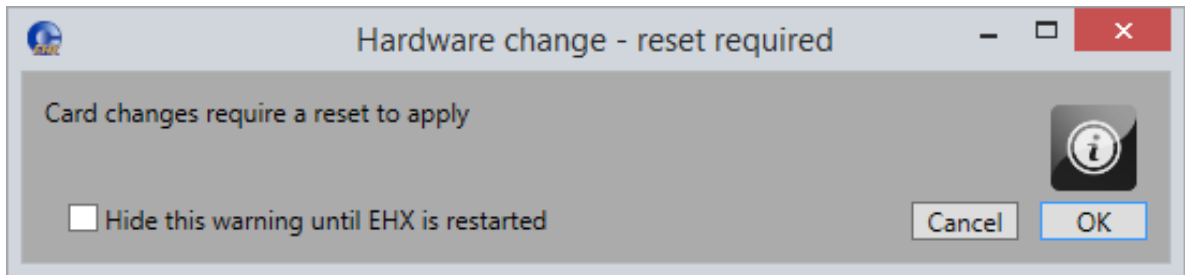

Figure 6-2 Hardware change

6.2 Matrix hardware

The **Hardware** menu is used to build up the configuration of the Eclipse HX system.



Figure 6-3 Hardware menu

The Eclipse HX system combines hardware items with port functions. Hardware items may include configuration cards, interface cards, ports (panels or Interfaces) and RLY-6/GPI-6 modules. Port functions also use this link and provides access to the advanced settings for ports and where local preferences are configured.

Note: To build a configuration, at least one card of any type, apart from E-FIB (fiber only) must be configured in an Eclipse HX-Omega, Eclipse HX-Median or Eclipse HX-Delta matrix. If no cards are fitted, the first available slot should be configured in EHX as if an MVX-A16 card or E-QUE wireless card was present for the map to build.

6.3 Selecting card slots

When in the Cards and Ports menu, you have a list of card slots in the left-hand side of the System Pane. You can select a slot by clicking on it. You can select multiple slots by pressing the Shift key and clicking. You can also select and deselect non-adjacent slots by pressing the Ctrl key and clicking.

6.4 Selecting ports on the card

When you select a card in the list of Card Slots, you see all the card's ports, configured and unconfigured, in the System Pane.

Note: If you use the shift and Ctrl keys to select more than one card, only configured ports are shown.

6.5 Port list options

Click **Port Options**  at the top of the screen to hide or show the **Show All Ports**, **Detect New Hardware** and **Show Alt Text** buttons, and the **Search** dialog.

6.5.1 Show all ports

When you select this option, all the cards are selected, and all configured ports on any card are shown in the System pane.

6.5.2 Detect new hardware

If the matrix is available on the network (the correct firmware has been loaded and the IP address has been set up), the hardware can be auto-detected by clicking **Detect New Hardware**. It will detect new matrix cards, panels and interfaces.

6.5.3 Show Alt Text

There is an alternative text key called **Alt Text** that you can configure on panels to enable text to change between normal text and alternate text.

The **Alt Text** key can be placed anywhere on a panel. This key can be placed on all shift pages concurrently if desired to allow easy access.

When selected, it will turn red, and the panel will show the alternate text.

Dynam-EC (and 3rd-party HCI clients) alias text labels will override whichever state the panel is in. For more information, see the Dynam-EC User Guide. You can enter alternate text on all the entity screens. You can toggle the **Alt Text** button to show or hide the alternate text.

One possible use of alternate text is to set up a dual language configuration on the panel, for example to allow panels to display Arabic by default in a Middle Eastern broadcast installation. English speakers could then select the **Alt Text** key on a panel to see the English equivalents to the Arabic labels.

Another use could be that both the role name and user name could be configured for each panel or beltpack port. This would allow panel users to see either the name or the role depending on the Alt Text mode selected.

Click **Alt Text** to display or hide the alternative text column.

6.6 Port number

The **Port Number** field is non-editable. Port numbering is presented in the format **<Card>.<Position> (<Absolute Position>)**, where:

<Card> is the card slot of the interface card.

<Position> is the port number on the interface card.

<Absolute Position> is the port number that is achieved by counting through all the ports on the matrix (including all the ports on the cards that were installed to the matrix before this card).

6.7 Port function

Each port in a system must be assigned a port function which specifies the port's intended use, including what type of device is connected to the port.

The port's intended use is important as the system treats a port differently if it is connected to a user panel rather than a telephony interface for example.

Port Function can be entered manually, or automatically detected by the Detect Hardware feature if devices that support the function are connected and powered.

The Port Function column displays each port's functions in the current configuration. Each line in this column features a drop-down menu listing the available port type options. These options vary for different matrix cards.

6.8 Label

This is a label for the port used to assign the port to a path. The label has 10 characters, or can be split into two parts, each of maximum five characters. It is a global setting. To specify the label format:

- Select **Tools > Enable Ten Character Labels** for 10-character labels
- Deselect **Tools > Enable Ten Character Labels** for two five-character labels

Note: Individual ports can be set to 5-character mode using the split label option.

6.9 Description

This is an optional description of the port, up to 255 characters long.

6.10 Search Ports

Enter a key word to search for ports on the matrix.

6.11 Search Properties

Enter a key word to search for configuration options in the Properties drop-down menus.

6.12 System configuration limits

The configuration limits for the Eclipse HX matrix system are as follows:

Configuration item	Limit (Max. number)
Fixed Groups	999 (across whole linked set)
Partylines	399 (across whole linked set)
Partyline members	64
IFBs	200
GPSF	3200
Controls	999
Physical ports	496 (36 on Eclipse HX-PiCos)
Beltpack roles	200
Matrices	64
Keys	249600
Key Groups	100 (across whole linked set)
Sort Groups	64 per frame

Table 6-1 System configuration limits

6.13 System hardware limits

The following limits apply:

- IVC-32, E-Que and LMC-64 cards are high-power devices, and you can only install a total of four of these cards in an Eclipse Median or Delta frame. If more high-power cards are installed, the CPU only services the first four cards (based on lower slot numbers). In this case, a warning message is sent to the event log every 10 minutes. See section **27.2 Matrix event log**.
- In an Eclipse Omega frame that is fitted with a Power-One PSU (720379Z), you can install up to a total of six high-power cards. In this case, you are recommended to install a fan tray. However, you cannot install more than four antenna/splitter E-Que cards, or more than four E-Que cards with EM Signalling enabled. For more information about the Power-One PSU (720379Z), including part number see section **5.7 Power Supplies** in the *Eclipse HX Omega User Guide*.

This information is summarized in the table below:

Card	Maximum number with Power-One PSU (720379Z)	Maximum number with other PSU
IVC-32	6	4
LMC-64	6	4
E-Que antenna/splitter	4	4
E-Que with EM signalling enabled	4	4
E-Que other	6	6

Table 6-2 System hardware limits

If you attempt to add a high-power card to a matrix that already has the maximum number installed, a warning displays.

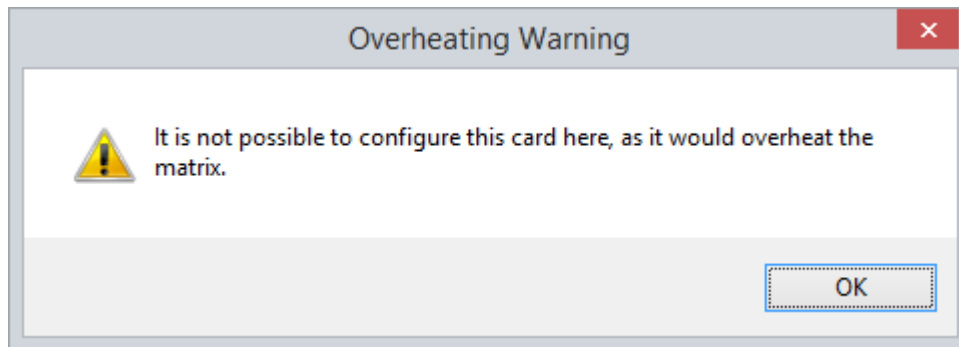

Figure 6-4 Overheating warning

If you add fifth or sixth high-power card to an Omega matrix the following message appears:

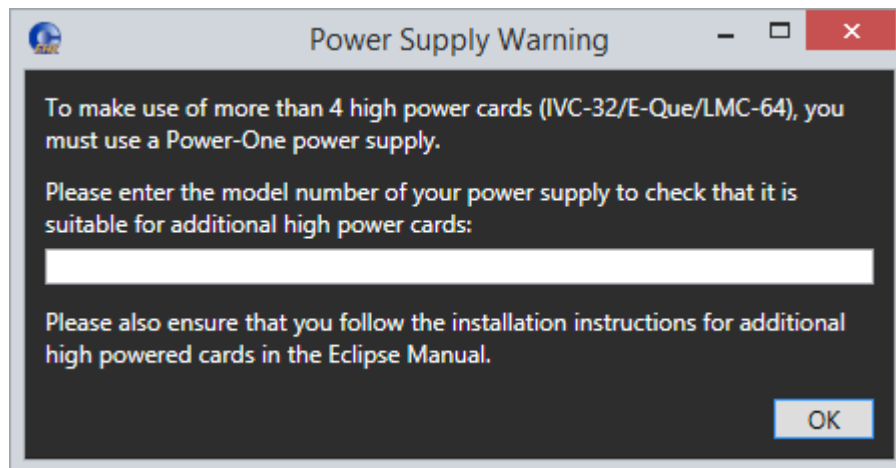

Figure 6-5 Power Supply Warning

To continue, add the model number of your PSU.

Note: Fitting a fan tray is recommended if you install more than four high-power cards.

6.14 Go Live configuration

Go Live configuration allows the EHX user to directly access configuration information from the matrix and update the matrix configuration used by EHX. All the Live Configuration facilities require an Ethernet connection to the matrix.

Note: Go Live mode is described in more detail in **24 Go Live mode**.

7 Applying Eclipse HX changes

When you create or edit a configuration or add hardware to the system, you must apply the changes to the Eclipse HX system before any changes can take effect.

Note: You can create and edit a configuration file and save it for later use without applying the map. However, you must apply the file to a matrix before the changes can take effect.

Do one of the following to apply the configuration:

- Select **Tools > Apply Changes To Matrix**.
- From the Layout Pane, right-click the matrix and then select **Apply Map To Matrix**.
- From the Main Menu, select **Apply Map To Matrix**.
- From the keyboard, press **CTRL+D**.

The first two methods of applying changes to the matrix merge the new configuration with the existing configuration. They also enable the user to select the reset type.

The third method only applies a new configuration to the system.

7.1 Apply map to matrix

- 1) Select **Tools > Apply Changes To Matrix**.

When this function is selected, a dialog is displayed to confirm the action.

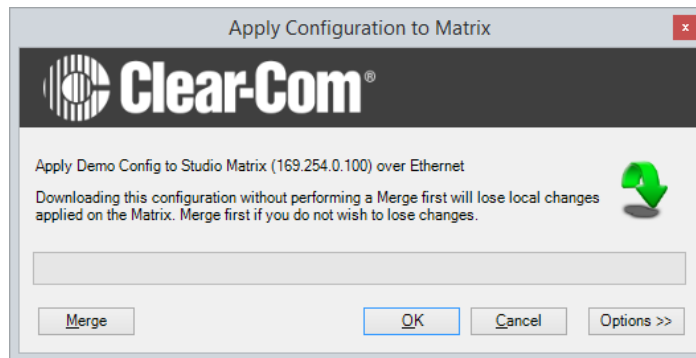

Figure 7-1 Download Dialog

In both cases these changes are reflected in the current EHX configuration and would be lost if an apply was performed without first merging the configurations. The merge button has the same effect as performing a merge in Go Live mode and displays the same informatory messages.

- 2) To continue, click **OK**. To cancel, click **Cancel**.

The options button displays a further dialog allowing the user to set up actions after the apply.

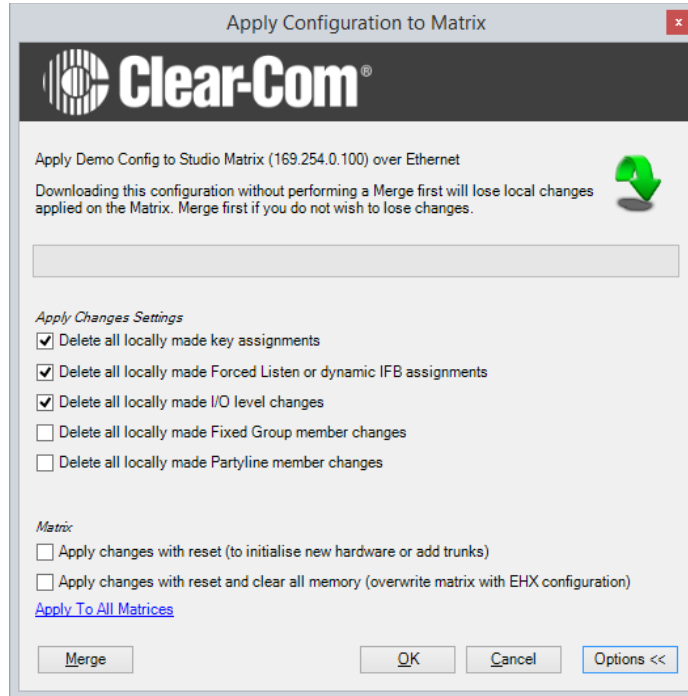

Figure 7-2 Apply Configuration to Matrix Options

- 3) Select **Merge** to allow the current EHX configuration to be merged with the matrix configuration before applying the map. Use this facility if the rack configuration has been changed because of making changes in EHX Go Live mode or from assignment panels.

Note: This is not necessary if applying changes without a reset.

- 4) Select the required option (or options) and then click **OK** to continue applying the map.

The configuration is built and applied to the matrix.

7.1.1 Apply changes with reset

- 1) Select **Apply changes with reset (to initialise new hardware or add trunks)** to reset the matrix and any crosspoints. Talk/Listen paths are remade.

This type of reset is required for:

- Applying completely new configurations
- Hardware changes

- Any locally assigned keys are cleared.
- Trunk changes

7.1.2 Apply changes with reset and clear all memory

- 1) Select **Apply changes with reset and clear all memory (overwrite matrix with EHX configuration)** to clear down any active routes and reset the matrix to the EHX default configuration. Any local changes to groups, partylines or IFBs made through i-Series panels, V-Series panels and Dynam-EC are reset to the EHX map default.

This type of reset (also known as a Black reset) is used for:

- Correcting erroneous or spurious crosspoints.
- Any locally assigned keys are also lost.
- Crosspoints - all active keys are reset to off.
- Crosspoint levels - all panel listen levels are reset to normal.
- Locally assigned keys - any locally assigned keys are deleted, including Fast Assign Keys.
- Local panel microphone settings - all panel microphone settings are set to the EHX downloaded value.
- Local panel sidetone gains are set to the EHX downloaded value.
- Key status - all keys are unmade.
- Any local changes to groups, party lines and IFBs made through i-Series panels, V-Series panels and Dynam-EC are reset to the EHX map default.
- Locally assigned fixed groups - all groups are reset to the EHX default.
- Locally assigned partylines and Dynam-EC -all partylines are reset to the EHX default.
- Locally assigned IFBs and Dynam-EC -all IFBs are reset to the EHX default.
- Locally assigned forced listens and Dynam-EC -all Forced listens are reset to the EHX default.
- Input levels - Matrix input levels are reset to the EHX download value.
- Output levels - Matrix output levels are reset to the EHX download value.

- OTA registration – OTA registration is cleared. Therefore, any registrations that have not been retrieved will be lost.

7.2 Apply to all matrices

Select this option if the EHX operator:

- Is making the first download of a new linked set.
- Has added or removed a Reserve Port.
- Has added a remote member to a partyline.
- Has added a remote key to a partyline.
- Has changed the trunk lines of any type.

7.3 Preserving locally assigned keys

When a map is applied, all the locally assigned keys (keys assigned from a panel rather than EHX) are lost unless a merge operation is performed before the apply. If you wish to retain these keys in the new configuration:

Go into Go Live mode and merge the locally assigned keys with the new configuration before applying and then save the modified project.

The configuration can then be applied with the locally assigned keys preserved in the new configuration.

7.4 Apply changes to all matrices

- 1) Select **System > Apply Changes to all Matrices** to apply a configuration to all matrices in the system. Clicking this function opens the following dialog. The dialog includes reset options.

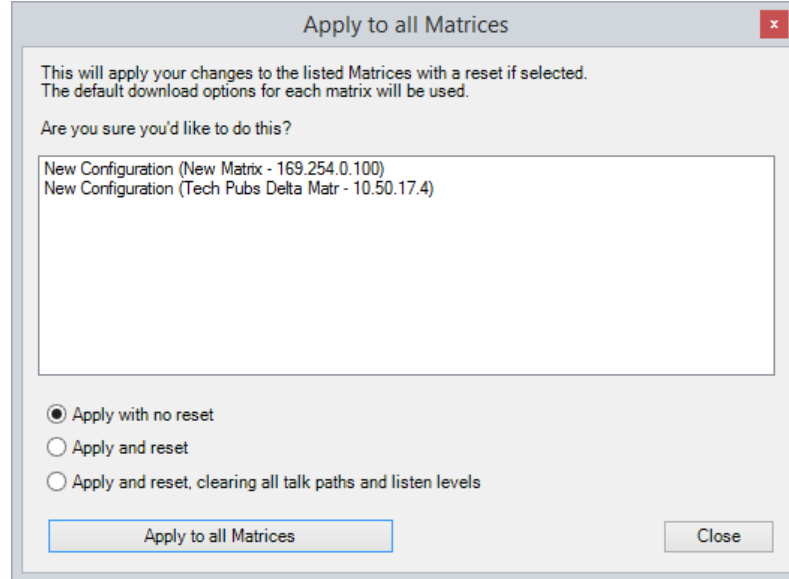

Figure 7-3 Apply Changes to all Matrices

The reset options comprise:

- **Apply with no reset.** The configuration is applied without resetting the matrices in the system.
- **Apply and reset.** The configuration and a red reset is applied to the matrices after applying (the matrices and any crosspoints are reset, and Talk/Listen paths are remade).
- **Apply and reset, clearing all talk paths and listen levels.** The configuration and a black reset is applied to the matrices after applying the map (the configuration is applied, the matrices are reset, and active routes and local assignments are cleared).

2) Select an option. To continue, click **Apply Changes to all Matrices**.

Note: When you apply changes to all matrices without a reset, the changed configuration is applied to each matrix in parallel. However, the configuration on each matrix is processed sequentially, from low matrix ID number to high matrix ID number.

7.5 Configuration application preferences

From **Configuration > Preferences > Apply Map** you can specify which of the options are selected by default when applying changes to matrix frames.

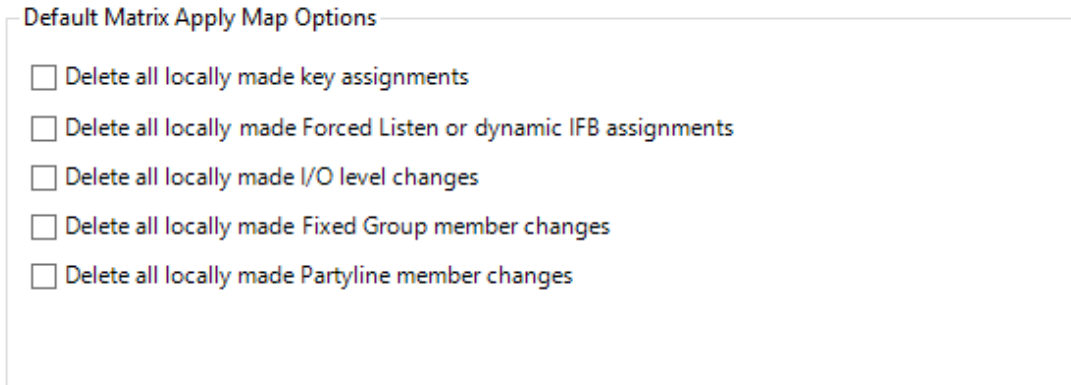

Figure 7-4 Default Matrix Apply Map Options

You can select (or deselect) one or more of the following options (the default is deselected):

- **Delete all locally made key assignments** (Key assignments that were made locally from either panel menus or in Go Live mode).
- **Delete all locally made Forced Listen or dynamic IFB assignments** (IFBs or Forced Listen assignments that were made locally from either panel menus, Dynam-EC or in Go Live mode).
- **Delete all locally made I/O level changes** (Input and Output levels that were modified by panels or Dynam-EC. Crosspoint I/O levels are unaffected).
- **Delete all locally made Fixed Group member changes** (Fixed Group members that were modified from a panel).
- **Delete all locally made Partyline member changes** (Partyline members that were added locally from a panel).

Note: The following option only applies if an E-QUE FS II-TA Antenna/Splitter is configured.

- **Delete all un-fetched over-the-air beltpack registrations** (Deletes all beltpacks registered over-the-air but not yet brought into the configuration using **Hardware > Beltpacks > Fetch Registered Beltpacks From Matrix**. See section **20.2.2 Fetching registered beltpacks**.)

8 Adding and configuring an MVX-A16 card

The MVX-A16 is a 16-port matrix card designed to connect 16 intercom panels, interfaces or external four-wire devices to the Eclipse HX System (Eclipse HX-Omega, Eclipse HX-Median and Eclipse HX-Delta only). MVX-A16 cards can be added, removed and viewed in the matrix hardware screen.

8.1 Adding an MVX-A16 card (automatic discovery)

The MVX-A16 card is automatically discovered when:

- You select the **Discover Hardware** option after the Matrix is placed on the **System Layout** from the discovery pane.
- You right-click a matrix on the **System Layout** screen, and then select **Configuration > Select New Configuration > Discover Hardware**.

8.2 Adding an MVX-A16 card (manual)

To add an MVX-A16 card:

- 1) In **Hardware > Cards and Ports**, navigate to an available slot number (marked **Empty**). Do either of the following:
 - Double click the slot.
 - Right click the slot and select **Set Card Type**.
- 2) A drop-down menu is displayed, listing the available card types. Select **MVX-A16**.

After you have added a card, you can move it to another card slot as follows:

- 1) Right-click the card slot to be moved, and select **Move Card**.
- 2) Right-click the required empty card slot, and select **Paste Card (Move)**.
The card moves to its new position.



Figure 8-1 Eclipse HX Empty Slots

3) Repeat this step for the number of required MVX cards.

Note: MVX-A16 cards must already be fitted into the Eclipse HX matrix with no empty slots left between the cards.

Note: You can also change an existing card by right-clicking the slot and selecting **Set Card Type**. (Changing the type of card deletes any ports, panels and keys that exist on the card).

When you add or remove card to the matrix configuration, the following screen might appear unless the **Hide this warning until EHX is restarted** option has been selected:

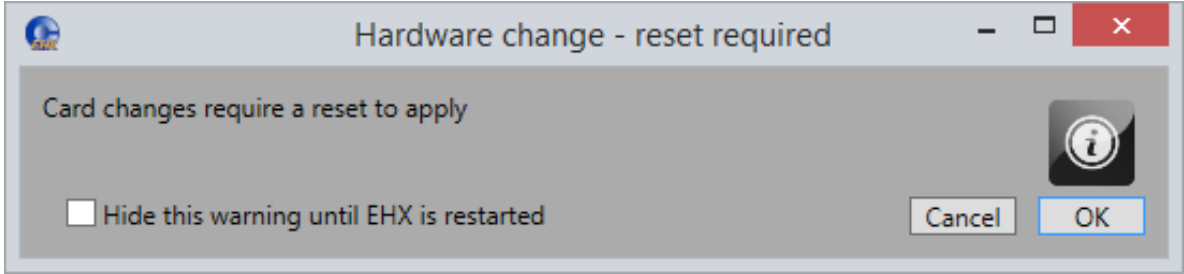

Figure 8-2 Hardware change

Click **OK** to continue.

If your configuration contains linked matrices, the following message might appear when you try to apply changes to the matrix:

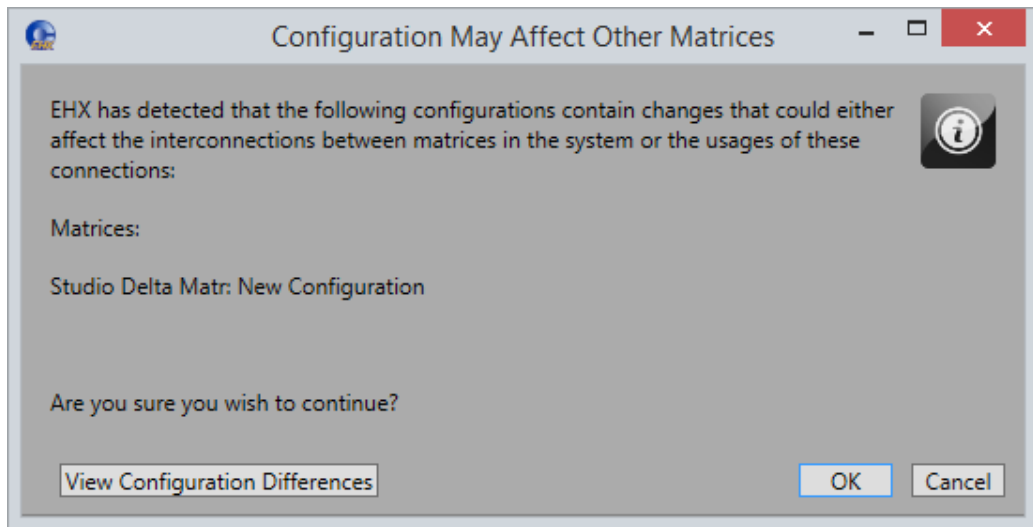

Figure 8-3 Configuration may affect other matrices

- 4) Click **View Configuration Differences** to see a list of possible interconnection issues.
- 5) Click **OK** to continue, or **Cancel**.

8.3 Removing an MVX-A16 card

To remove an MVX-A16 card from the configuration:

- 1) In **Hardware > Cards and Ports**, navigate to the slot number of the MVX-A16 card you want to delete.
- 2) Right click the slot and select **Set Card Type**.
- 3) A drop-down menu is displayed, listing the available card types. Select **Empty**.

- 4) A warning dialog is displayed. To confirm the deletion, click **Yes**.

When you remove a card, the warning message (Hardware change – reset required) above might appear.

8.4 Setting the port function

To set the port function:

- 1) Click the Port Function field. A drop-down menu is displayed.

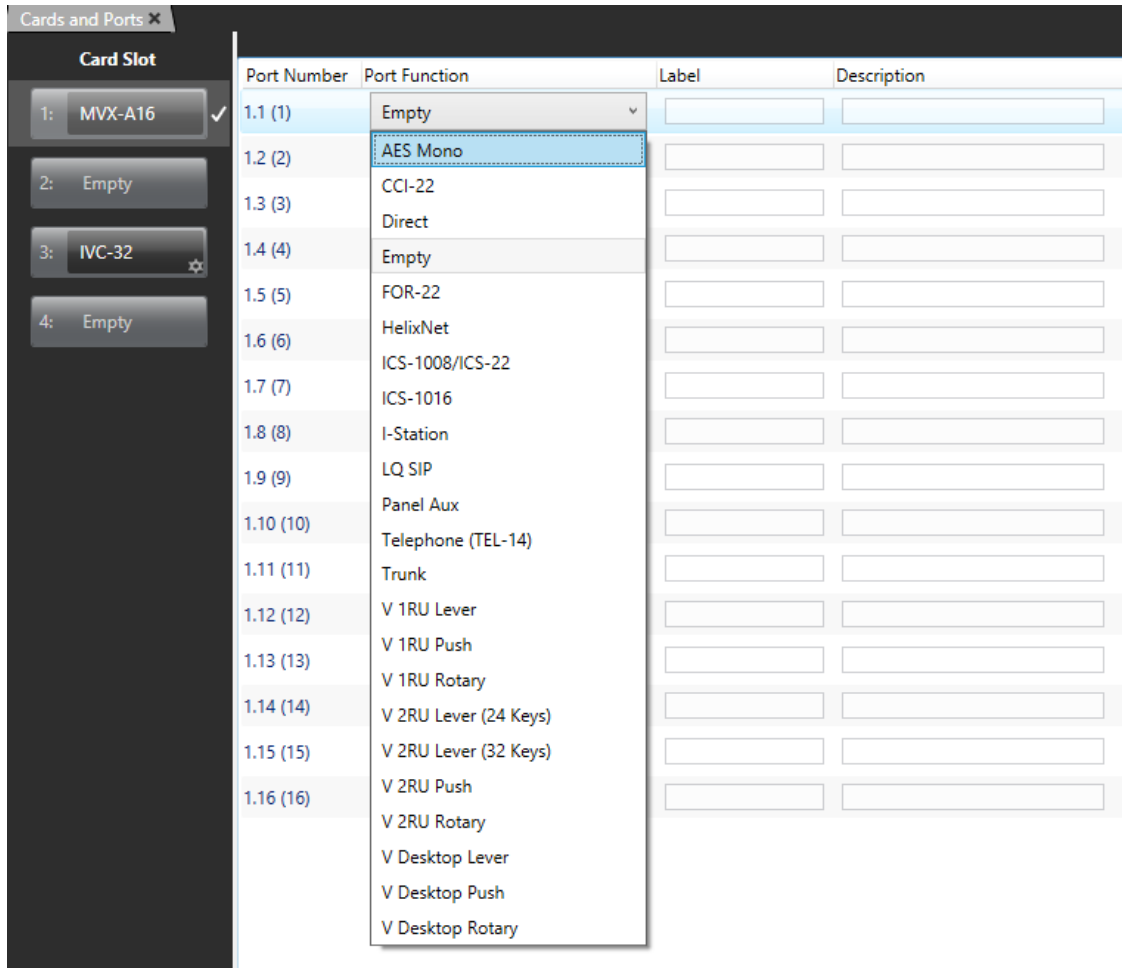

Figure 8-4 Port Function

- 2) From the drop-down menu, select the desired device (user panels and interfaces that may be connected to the port).

The available device types are listed below:

- Empty
- V 1RU Lever

- AES Mono
- CCI-22
- HelixNet
- ICS-1008/ICS-22
- ICS-1016
- Direct (4 wire external)
- FOR-22
- I-Station
- LQ-SIP
- Panel Aux
- Telephone (TEL-14)
- Trunk (matrix to matrix network trunk line)
- V 1RU Push
- V 1RU Rotary
- V 2RU Lever (24 Keys)
- V 2RU Lever (32 Keys)
- V 2RU Push
- V 2RU Rotary
- V Desktop Lever
- V Desktop Push
- V Desktop Rotary

Note: You can configure a port for an ICS-22 panel. See section **17.14 ICS-22 panels**.

Note: If you right-click on a port and select **Find Usages**, a list of other EHX entities which refer to the port is given.

8.4.1 Device details

- AES Mono** Used with the AES-6-RJ and AES-6-CX interfaces providing a monaural connection to third party equipment.
- CCI-22** Used with the CCI-22 interface card, or other interface to a physical 2-Wire Party Line. Call signals are sent to and received from an external Clear-Com party line in the same way that they are sent between panels within the Eclipse HX System.
- HelixNet** Used with the HelixNet digital partyline system.
- ICS-1008/22** Used with the 1RU ICS-1008 panel and the ICS-22 panel.
- ICS-1016** Used with the 1RU ICS-1016 panel.
- Direct** Used to connect directly to an external 4 wire or balanced audio device.
- FOR-22** Used with the FOR-22 interface card. This has several different functions. The commonly used applications are:

Two-Way Radio—When the 2-Way Radio port function is selected, the port is configured to operate a push-to-talk two-way radio system. The call signal output activates a relay to key the radio’s transmitter.

If the FOR-22 is to be used as a 2-Way Radio from remote systems, the FOR-22 relay should be added as a secondary action in **Attached Control Options**. When the FOR-22 is in 2-Way Radio mode, the matrix has control of the relay and automatically fires it.

Four-wire —When the port is wired directly to an external device. Normally four-wire functions are only audio connections and do not use call signals. By default, when a four-wire port is connected to a FOR-22 four-wire Audio Interface, a call signal sent to the port from the Eclipse HX System activates the FOR-22 channel’s relay. Alternatively, this relay can be activated by attaching the relay name to a control label configured in the Control Manager.

When the FOR-22 is in four-wire mode the relay will not automatically fire. To make the relay fire when a talk path to the FOR-22 is created a control must be created and added as a secondary action in the **Attached Control Options** for the FOR-22.

When enabled in Partyline mode the FOR-22 allows panels to listen to all commands to/from the interface.

- I-Station** Used to drive an I-Station.
- LQ SIP** Used to connect a matrix to an LQ device SIP client.
- Panel Aux** Used with an AES-6-CX/RJ interface providing a binaural connection to a panel supporting split-ear operation. This port type must be configured as part of a pair of ports to provide a binaural connection to the panel. The first or master port of the pair is configured for the attached panel in the normal way and the Aux Port is the second port configured under Basic Settings.
- TEL-14** Used to operate a TEL-14 telephony interface. The call signal output is used as a request from the Eclipse HX system for the interface to go off-hook. A call signal sent from the TEL-14 interface to the Eclipse HX indicates that the line is ringing or that the line is off-hook.
- Trunk** Used to allow the port to function as an intelligent trunk line to a remote matrix. The linking network matrices must be configured in the **System** pane and cannot be configured from the Matrix Hardware setup. The **Linking Options** shown under the **Advanced Settings** menu is for information only.

V 1RU Lever

These options are all used with V-Series panels.

V 1RU Push

V 1RU Rotary

V 2RU Lever (24 Key)

V 2RU Lever (32 Key)

V 2RU Push

V 2RU Rotary

V Desktop Lever

V Desktop Push

V Desktop Rotary

8.5 Port properties

To edit port properties, go to **Hardware > Cards and Ports**, and then select the required port. In the right-hand window, select the required property drop-down list.

8.5.1 Basic Options

The screenshot shows a 'Search Properties' window with a search icon in the top right. Under the 'Basic Options' section, the following fields are visible:

- Port Number: 1.11 (11)
- Alias (Remote Matrix): [Empty]
- Alt Text: [Empty]
- Comments: [Empty]
- Description: HelixNet
- Dial Code: 02.01.011
- Module Application: HelixNet (dropdown menu)
- Label: [Empty]
- Reserve Port:
- Split Label:

Figure 8-5 Basic Options

The following Basic Options are available:

Port number

The port number the device is configured on.

Note: Not available on Concert panels.

Alias (remote matrix)

Specifies the remote system the trunk device is connected to. This is configured in **System** and is displayed in **Port Properties** for information only. It cannot be set using Advanced Settings.

Note: Only used on Trunk devices.

Alt Text

Provides an entry field for the alternative text label on this port.

Comment

Enter an optional comment about the port and what it is used for.

Description

Enter an optional description about the port and what it is used for.

Dial code

Provides information on the unique dial code for this port. This is used in fast key assign operations on a panel.

Module application

This option is only available if the MVX-A-16 card port is configured as:

- CCI-22
- HelixNet
- Direct
- FOR-22

This allows you to select the application type for the module:

- Partyline - this is used with a CCI-22 interface module to connect to an Encore Partyline system. See section **8.4.1 Device details**.
- Two-Way Radio – this is used with a FOR-22 interface module to connect to a third-party two-way radio system. See section **8.4.1 Device details**.
- Direct – this is used with a four-wire connection
- HelixNet – this is used with the HelixNet digital partyline system.

Note: The **Module Application** selection is also available with the IVC-32 card when **Port Function** is set to **Hosted Direct**. Hosted Direct is an option to enable up to two additional IP channels on an IVC-32 card.

Note: If you select Partyline, Two-Way Radio or HelixNet on a **second** additional IP hosted direct sub-channel, the **Mute Relay** option for the parent channel is no longer active.

Note: There is no DTMF support for the Module Applications.

Label

The port label specified in the port settings table (a combined Talk/Listen label is shown unless the option for 10 character labels is turned off).

Split label

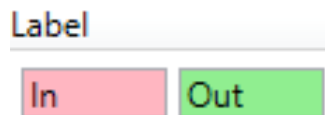

Figure 8-6 Split lable

If Split Label is set, the first five characters and the last five characters of a label are displayed separately. This allows you to treat the input and output of a port as separately labeled entities. If this option is not set all ten characters are shown (on panels that support ten characters). The main label is colored red and green to denote split ports.

Reserve port

Reserves a unique trunk port for this label. This only applies to E-FIB trunks unless the trunking is between a two-matrix linked set, when it also applies to non-E-FIB trunks.

Note: Not available for AES Mono and Panel Aux.

8.5.2 Panel options

These options are only available on ports that are configured as V-Series or I-Station panels.

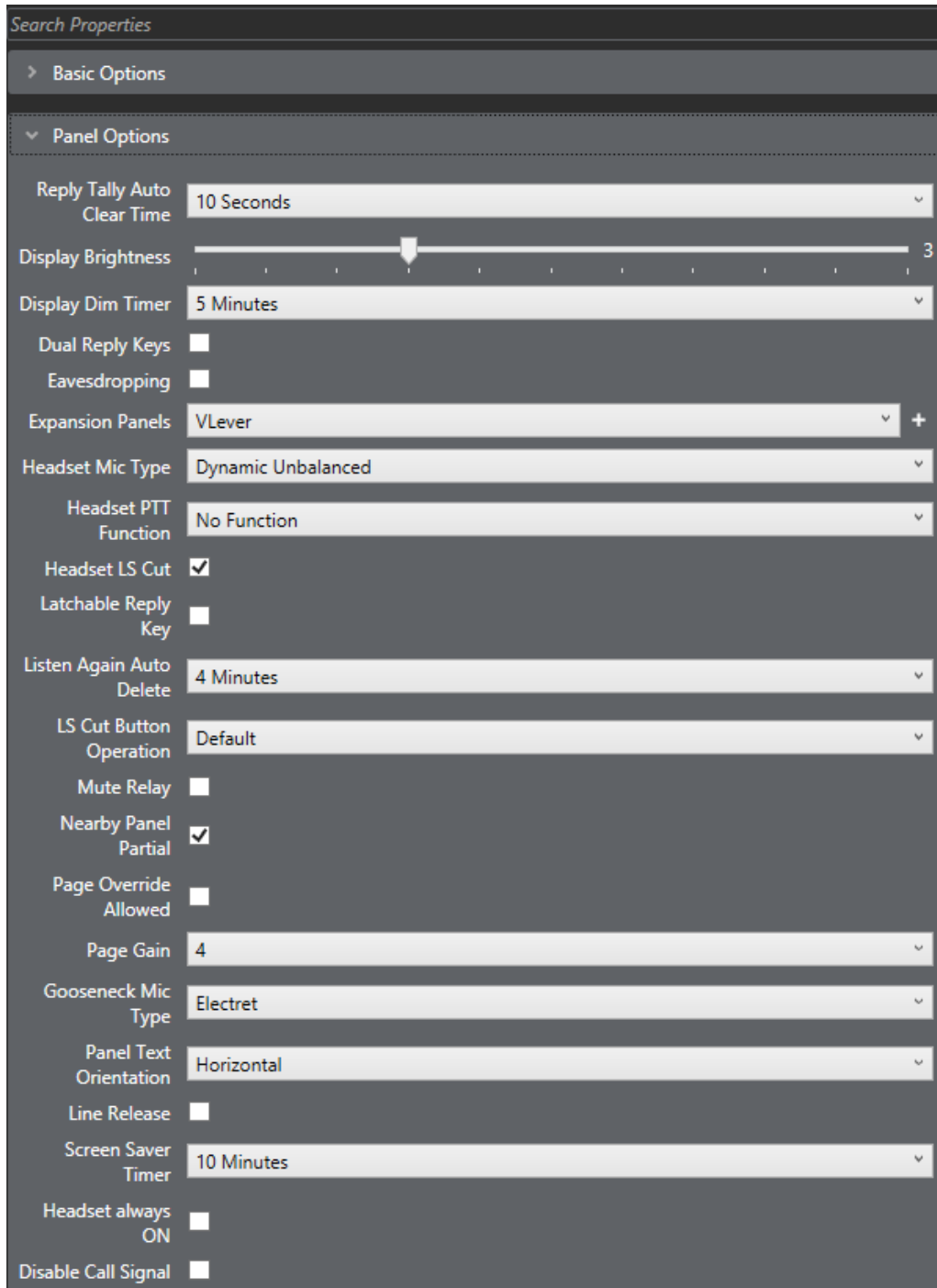

Figure 8-7 Panel Options

The following Panel options are available:

Reply tally auto clear time

The time a port name/tally LED shows on the reply key before it is cleared. To adjust the time, select answerback time to display the slider and set the time as required. The time can be set from 1 to 60 seconds. Setting to **off** prevents the system from clearing the reply tally automatically. The default is 10 seconds.

Display brightness

Sets the display brightness on panels that have a suitable display. To adjust the display brightness, select the brightness box to display the adjustment slider and use the mouse to drag the slider to the required setting. The brightness is adjustable from 0 to 10. The default setting is 3.

Note: Not available on Concert panel.

Display dim timer

Sets the time interval in minutes before the display on an inactive panel is dimmed to extend the display's longevity. To adjust the time setting select the timer box to display the adjustment slider and use the mouse to drag the slider to the required setting. The timer is adjustable from 1 minute to 60 minutes. A setting of **Always Dim** forces the display to permanently show the dim state.

Note: Only available V-Series panels.

Dual reply keys

Select this option to add a second Reply key to a V-Series Panel. By default, the second Reply key is added immediately to the right of the first Reply key. If this position is in use, a message is displayed allowing you to overwrite this key or to select a new location for the second Reply key. To select a new location, use the REPLY 2 special entity in panel programming.

Note: You can only reply to the last two calls. Calls are not stacked.

The following points apply:

- If neither Reply key has incoming calls, the first Reply key is always populated first.
- If both Reply keys have incoming calls, another incoming call replaces the older of the two original incoming calls.
- If a Reply is latched, it will not be replaced by another incoming call.
- If both Reply keys are latched, further incoming calls will be heard but will not appear on the Reply keys.

Note: Only available V-Series panels.

Eavesdropping (privacy)

When this is deselected, other panels cannot eavesdrop on a panel’s microphone input, unless that panel has an active talk key pressed to another port in the Eclipse HX System. If this box is checked, other panels can monitor a panel’s microphone input, even without any activated talk keys. By default a panel’s microphone output is off until a talk key is pressed. The panel’s Mic ON/OFF control always takes priority over eavesdropping.

The default setting is disabled.

Note: Eavesdropping must be enabled (checked) for a panel to act as an ISO destination is set so that the panel microphone can be remotely enabled by the ISO if it is not enabled at the destination.

Expansion panels

Some types of panels can support multiple expansion panels. If this option is available selecting the expansion panel number attached box opens a menu showing the type of expansion panels that can be fitted to the host panel. The types of expansion panels listed vary according to the main panel type.

Main panel	Expansion panel
V12LD	V12LDE
V24LD	V12LDE
V12PD	V12PDE
V24PD	V12PDE
V12RD	V12RDE
V24RD	V12RDE
V32LD	V16LDE
V12LDD	V12LDE
V12PDD	V12PDE
V12RDD	V12RDE
i-Station	E Station, V Station

Table 8-1 Expansion panels

Headset mic type

The Headset Mic Type allows the type of headset microphone to be configured. To set the microphone type highlight the item to allow the drop-down menu to be displayed.

The options for headset microphones are Dynamic Balanced, Dynamic Unbalanced (default) and Electret. This setting applies to headsets 1 and 2 on panels that support multiple headsets.

Note: Only available V-Series panels.

Headset PTT function

The Push To Talk (PTT) function allows the action for PTT to be selected. The options are:

- No Function
- Activate All Talk Keys
- Activate Two-Way Radio.

The default is **No Function**. This function is triggered by any of the PTT inputs on a panel.

In the case of V-Series panels this function only relates to XLR-4 and XLR-5 type headsets that have been modified for PTT. V-Series XLR-7 headsets and headsets connected to the auxiliary audio connector use the logic 1 and 2 inputs (see section **8.5.12 Logic input options**).

These functions are:

- No Function - PTT has no effect.
- Activate All Talk Keys - PTT activates audio paths on all latched talk keys. Non-latching talk keys are not activated.
- Activate Two-Way Radio - PTT activates audio paths on all latched talk keys connected to two-way radios (normally via a FOR-22 unit).

Note: Not available on Concert panels.

Headset LS cut

When enabled this facility automatically cuts the audio to the panel loudspeaker if a headset is detected. The default setting is enabled.

Note: Only available on V-Series panels.

Latchable Reply Key

This facility enables you to set the Reply Key as latchable. When it is latched, the Reply Key will not timeout. If you have stacked Reply Keys, a latched Reply Key is unlatched if you leave the Reply Key when navigating stacked keys with the up and down volume keys. The key is also unlatched after doing a red reset, see section **7.1.1 Apply changes with reset**.

Note: If the incoming call is from a panel that has **Global Options > Latch Disable** checked, the Reply Key will not latch even if **Latchable Reply Key** is checked. If a different panel, without this setting, calls in this key can be latched.

Note: Only available on V-Series panels.

Listen again auto delete

The Listen again auto delete timeout sets the length of time in minutes before a message recorded in the listen again buffer is automatically deleted. It ranges from 1 to 100 minutes. It is possible to disable the autodelete.

Note: Only available on V-Series panels.

LS cut button operation

This configures the behavior of the V-Series Panel Loudspeaker (LS) Cut button. There are four settings available:

- Default – the LS Cut button toggles between on and off. When on, the loudspeaker and auxiliary loudspeaker audio is muted.
- LS Cut ON & Btn disabled – The loudspeaker and auxiliary loudspeaker audio is permanently muted.
- LS Cut OFF & Btn disabled - The loudspeaker and auxiliary loudspeaker audio is permanently available.
- ON & Btn disabled if HS detected - The loudspeaker and auxiliary loudspeaker audio is cut if a headset is detected and cannot be uncut until the headset is removed. Otherwise, the behavior is the same as Default.

Note: If the loudspeaker and auxiliary loudspeaker audio is cut, Page Override can temporarily enable it.

Note: Only available V-Series panels.

Mute relay

If this is enabled, the local panel GPO mute relay is fired when a Talk only key is pressed on that panel. The default setting is false.

Note: This function is not active if you configure the V-Series panel with a second additional sub-channel that has function Two-Way Radio, Partyline or HelixNet.

Nearby panel partial

This attribute affects the way that Nearby Panels configured in **Local Advanced** operate.

The **Nearby Panel Partial** attribute is set to **True** to enable audio from nearby panels to be routed to the headset. If it is not set audio from nearby panels is cut completely to prevent audio feedback.

Page override allowed

The panel main volume audio can be overridden by paging audio from another panel. The default setting is disabled. For Page Override to operate this must be set to True on any destination panel where the local main volume setting may need to be overridden by a calling panel. This is used in conjunction with Page Gain.

Page gain

Allows the Page Override gain to be set.

Select the required level. The level range is from 0 to 10. The default volume setting is 4.

This is used in conjunction with Page Override.

Note: Only available on Concert, V-Series and i-Series Panels.

Gooseneck mic type

The Gooseneck Mic Type allows you to select the panel microphone type.

There are three options:

- Dynamic Balanced
- Dynamic Unbalanced
- Electret

To set the microphone type, select from the drop-down list.

Note: Only available V-Series panels.

Panel text orientation

Determines the orientation of label text on V-Series panels. There are three options:

- Horizontal
- 90 Degrees Anti-Clockwise
- 90 Degrees Clockwise

Note: Only available on V-Series panels.

Line release

Allows the panel to release the selected telephone line which may be held on by the incoming caller anywhere in the system. The default is disabled.

Note: Not available on Concert.

Enhanced Tallies

Enables the enhanced tallies for rotary panel displays.

Note: Only available on rotary V-Series panels.

Keep hidden keys active

When enabled, the I-Station keeps calls on inactive shift pages alive. When disabled, any latched calls are ended when the user navigates away from the shift page. The default is disabled.

Note: Only available on I-Station Panels.

Screen saver timer

The screen saver timer facility sets the length of time before the screen saver is displayed on an inactive panel. The screen saver is used to prevent the display being damaged by being left for long periods with the same display. The time may be set to any value between 1 and 60 minutes. It cannot be disabled.

If the dim timer is set to a value other than Always Dim the screen saver timer only starts after the screen has dimmed. For example, if the dim timer is set to 1 minute and the screen saver timer is set to 1 minute the screen saver starts after 2 minutes. If the dim timer is set to **Always Dim** the screen saver inactivity timer starts immediately.

Note: Only available on V-Series Panels.

Headset always ON

This option forces the panel H/S button to be permanently ON. This means that a panel user cannot use a connected gooseneck microphone, even when a headset is not connected.

Note: Only available V-Series panels.

Disable call signal

This option prevents a panel user from sending a call signal.

Note: Only available V-Series panels.

Disable send level

This option is only available on rotary panels. It prevents a panel user changing the send level by pressing and holding the talk key and simultaneously turning the rotary control key.

Speaker Dim

Sets the dim level for the speaker when a talk key is pressed on the panel.

Note: Only available i-Series panels.

8.5.3 Assignment panel (AP) options

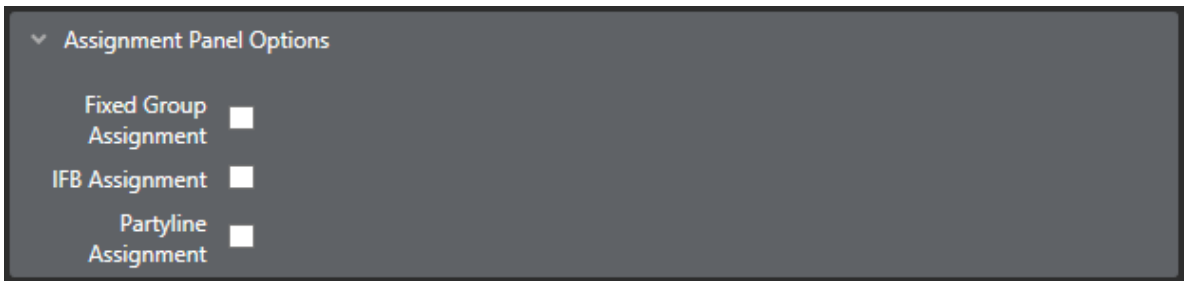

Figure 8-8 Assignment panel options

These options apply to V-Series and i-Series Panels only.

The **Port Properties** options for an AP panel (Assignment Panel) enable features that can be performed directly from the panel keys. They include:

- **Fixed Group Assignment.** Set to True or False (default False). Allows the panel operator to select ports to be assigned to a fixed group.
- **IFB Assignment.** Set to True or False (default False). Allows the panel operator to select ports as sources to be assigned to an IFB.
- **Partyline Assignment.** Set to True or False (default False). Allows the panel operator to select ports as fixed members of a party line.

8.5.4 Menu options

These options apply only to V-Series and I-Station panels. For more details, see section **17 Panel programming**.



Figure 8-9 Menu Options

Local preferences access

Allow access to the local preferences menu via the local menu option. This allows access to audio level control, brightness settings, timeouts and crosspoint reset. Access may be enabled for all users (True), denied to all users (False) or controlled by the PIN number.

Select the option and click on the arrow to open the drop-down menu. Select the required access.

Diagnostic menu access

Allow access to the panel diagnostic menu via the local menu option. This allows some panel information to be displayed and access to panel reset and telephone line release functions. Access may be enabled for all users (True), denied to all users (False) or controlled by the PIN number.

Select the option and click on the arrow to open the drop-down menu. Select the required access.

Note: Only on V-Series panels.

Messaging enabled

Allows V-Series panels access to the Messaging facility. This enables panel users to record messages that other users can hear when they talk to the panel.

This is commonly used in the commissioning / setting up of a system, or as an "out of office" / away from desk message. This feature is enabled by default.

Note: Only on V-Series Panels.

Dial Mode Access

Enables access to dial mode, where the panel has a dial pad for DTMF dialling. This is enabled by default.

Note: Only on I-Station Panels.

System Information Menu Access

Enables access to the System information menu on the panel. This allows the panel user to view major system settings. This is enabled by default.

Note: Only on I-Station Panels.

System configuration menu access

Allows access to the system configuration menu via the local menu option. This allows access to partyline, fixed group, remote panel, local panel, forced listen, input level and output level menus. Access may be enabled for all users (True), denied to all users (False) or controlled by the PIN number.

- 1) Select the option and click on the arrow to open the drop-down menu. Select the required access.

Note: Only on V-Series Panels.

Supervisor mode access

When 'Supervisor Mode Access' is enabled the panel has access to the Supervisor Mode via a new 'Supervise' key in the panel Menu. Alternatively, a special entity key 'SUPR' can be added directly to any page to access supervisor mode via the panel programming screen. For more information, see the V-Series Panels User Guide.

You can select whether the labels on a panel supervising or being supervised are inverted or not. To do so:

- 1) Go to **Configuration > Preferences > Panel & Key Operation**.
- 2) Select or deselect:
 - **Disable Supervisee Label Text Inversion** check box
 - **Disable Supervisor Label Text Inversion** check box.

Note: Only on V-Series Panels.

8.5.5 Voice operated switch (VOX) options



Figure 8-10 VOX Options

Four settings are available under **Port Properties > Voice Operated Switch**. These settings determine how the audio gate operates.

- **Audio Detection Release Delay** determines how quickly the audio gate closes when the operator stops speaking. Adjust this value so that the audio gate does not close too early and cut off words at the end of sentences or during small gaps.
- **Audio Gating** turns the audio gate function on or off. By default, this setting is off. This function gates (performs a logical AND) on the crosspoint and the VOX detection threshold. If the crosspoint is made from the port and the input VOX level exceeds the detection threshold, then audio is passed to the port.
- **Audio Presence Tally** (also known as VOX tally) causes a panel's listen key to flash on a panel whenever audio above the set threshold level is detected.
- **Audio Detection Threshold** sets the audio level at which the audio gate opens. Typically, the threshold value is set at the level of a human voice, so that when a person speaks into the microphone, the audio gate switches open to allow audio onto the intercom line. When the person stops speaking, the gating delay passes and the gate closes, even if background noise is present. Recommended levels are -3dB for panels and -20dB for interfaces.

If the VOX control option is configured, the control activates when the gate opens.

8.5.6 Global options



Figure 8-11 Global Options

The following Global options are available:

Auto listen

This function enables a port for auto-listen. When a panel activates a talk to a destination that is configured for auto-listen, a listen path from that destination back to the source panel is also activated automatically for the duration of the call. In this way, the source receives audio from the destination without the destination having to specifically activate a talk back to the source. It is generally used on interfaces and four-wires.

The default setting depends on the port type.

Note: For Auto Listen to work correctly on external four-wire ports the MVX-A16 port must have the destination TX/RX data pins looped together.

Auto signal tone (auto call signal)

This function enables a panel or interface port for automatic call signalling. If a talk path is activated to a destination that has been configured for auto-call signalling, the call signal is sent to the destination for the duration of the talk. Auto-call signals are most commonly used with external devices that require a control signal to activate them.

If a port set for auto-call signalling joins a partyline, or is preset to a partyline, an auto-call is not sent to the port if the talk is to the partyline.

The default setting is disabled.

For panels which support Auto Signal - Call Signal must be enabled.

Panel connected tally

This allows the system to set a tally (flashing LED) on a panel indicating that the corresponding panel is connected to the system. The default is disabled.

This is normally used on remotely connected panels where the panel to matrix communications may suffer from an occasional loss of service.

Not available for CCI-22, AES Mono, Panel Aux and Direct (no keys).

Global ISO

This function enables a panel or interface as a global ISO (Isolate) destination.

Any panel activating a talk to a global ISO destination creates a private, two-way talk path between that panel and the destination.

All other communications are interrupted by any call from any Panel or Interface in the Eclipse HX System. When the source terminates the call, its audio paths return to their previous state. When all ISO paths to the destination are deactivated, the destinations' audio paths return to their previous states. For ISO talks to also interrupt listens at the source, select the ISO Interrupts All Other Listens check box in **Configuration > Matrix Preferences**. The default is disabled.

ISOs are always local to the matrix so the source and destination must be devices on the same matrix. An ISO destination cannot be set to a remote matrix.

Note: If the destination of an ISO is a panel, then **Eavesdropping** must be enabled in **Panel Options** to activate the panel microphone if it is not already activated. If the destination is not a panel but a device such as a four-wire port **Eavesdropping** does not need to be enabled for the destination device.

Hardware detection

This option enables the matrix to detect what kind of module is connected to the port.

If you are using Optocore or BroaMan devices, ensure that this option is disabled.

Note: This option is only available for four-wire interfaces.

Global latch disable

This function prevents talk keys to the port latching. If a latch-disabled port is assigned to a talk key, the user can only talk to the port for as long as the operator physically holds down the key (PTT action). A latch-disabled port can be included in a fixed group or party line without automatically latch disabling the entire fixed group or party line.

The default setting is global latch enabled.

Mute listen with talk

This option mutes incoming audio when the Talk key is pressed.

Partyline turnaround

Any other ports that talk or listen to the port are automatically enrolled in a hidden partyline. This means that any other port that can listen to this port can hear every port that talks to this port.

Prevent reply signalization

Prevents key signalization for the port appearing on the reply key of any panels.

IFB caller priority

Allows you to assign an IFB priority when the port is used as an IFB caller. Priorities range from 1 (lowest) to 5 (highest). The default is 3.

Note: When a port is added to an IFB as a source to the IFB, the routing will be applied at priority 1 regardless of the setting in the field.

IFB

Select this box to make the port an IFB destination. To configure the IFB source, use the **IFB** screen (**Configuration > IFBs**) or the **Local Advanced** screen (**Configuration >Local Advanced**).

If you select the IFB box, the following screen appears:

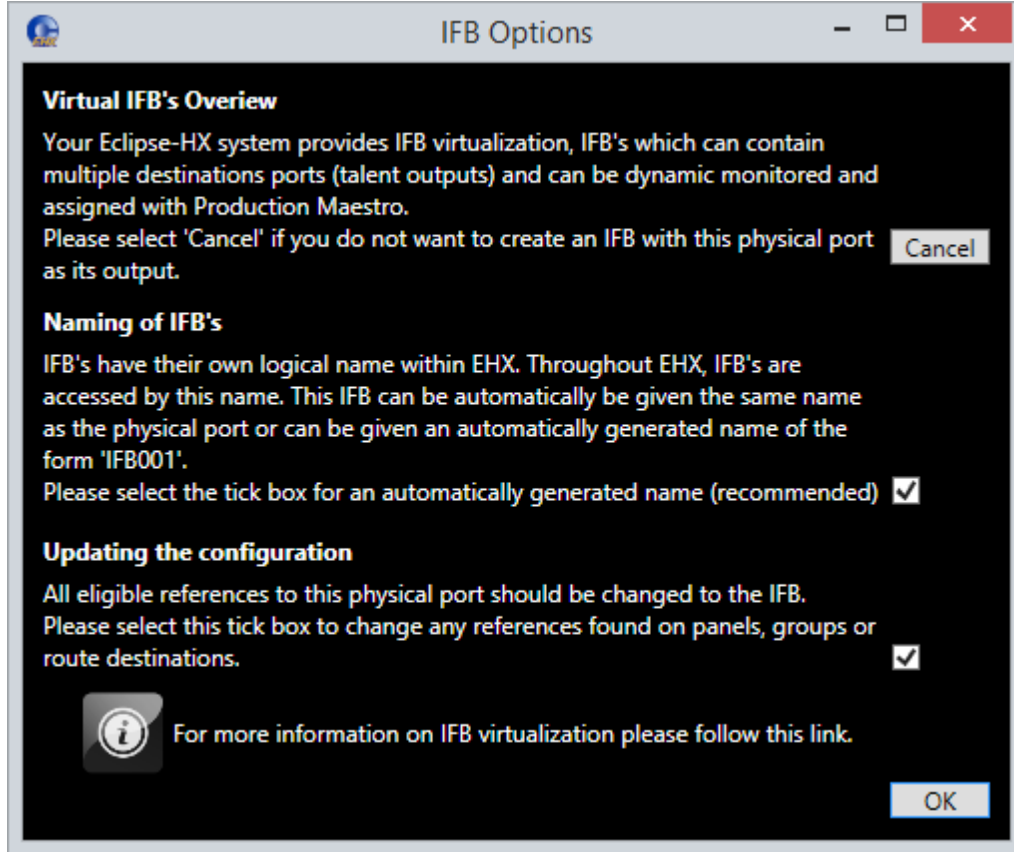

Figure 8-12 IFB Options

You can:

- Choose to have an automatically generated name for the IFB (recommended).
- Change all references to the physical port to refer to the IFB.

8.5.7 Telephone options

These options apply to LQ SIP and Telephone (TEL-14) port functions.

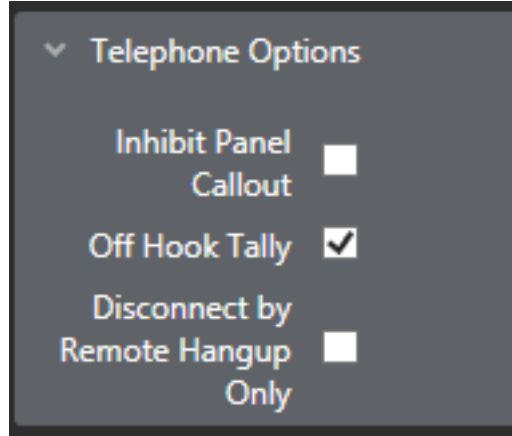

Figure 8-13 Telephone options

The following telephone options are available:

Inhibit Panel Callout

This option prevents a panel from manually dialling out on a telephone line.

Off Hook Tally

This option enables a tally light that flashes when the phone is off the hook.

Disconnect by Remote Hangup Only

This option disconnects the telephone call only when incoming caller hangs up.

8.5.8 Gain Options

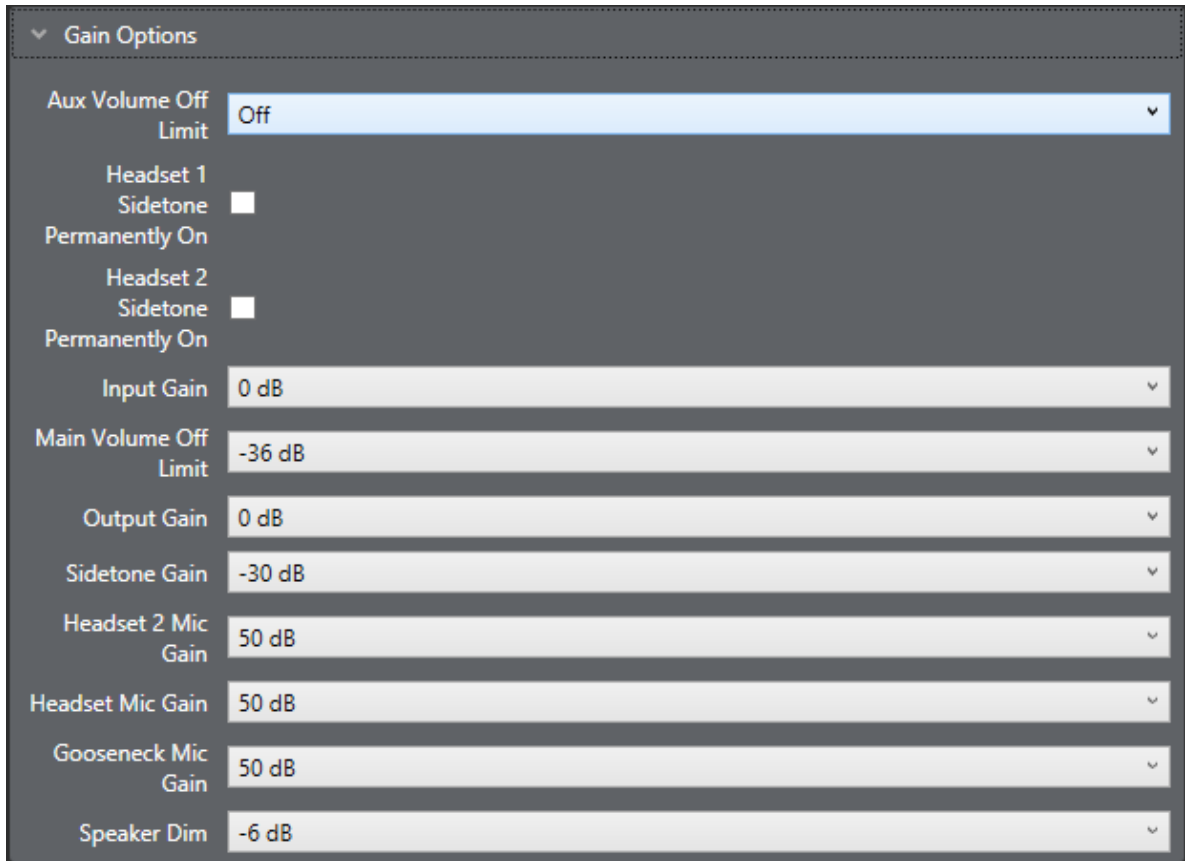

Figure 8-14 Gain options

The following Gain options are available:

Aux volume off limit

Sets the minimum limit for the auxiliary audio output so that the volume cannot be turned completely off. Default value is off, meaning the auxiliary audio can be turned off.

Note: Only available on V-Series panels.

Headset 1 sidetone permanently on

Turns the headset 1 sidetone permanently on.

Note: Only available on V-Series and I-Station panels.

Headset 2 sidetone permanently on

Turns the headset 2 sidetone permanently on.

Note: Only available on V-Series and I-Station panels.

Input gain

This adjusts the matrix input gain. Use the slider to set the required gain from +15 dB to -45dB (or type in the value). The default is 0dB.

Main volume off limit

Sets the minimum limit for the main audio output so that the volume cannot be turned completely off.

The default value is -36dB.

Note: Only available on V-Series panels.

Output gain

This adjusts the matrix output gain. Use the slider control to set the required gain from +15 dB to -45dB (or type in the value). The default is 0dB.

Sidetone gain

Sets the sidetone gain in dB for the panel. The default is -30dB.

Note: Only available on V-Series and I-Station panels.

Headset 2 mic gain

Sets the gain in dB for the panel headset 2 microphone.

Note: Only available on V-Series panels.

Headset mic gain

Sets the gain in dB for the panel headset microphone. The default value is 50dB for V-Series panels and -8dB for I-Station panels.

Note: Only available on V-Series and I-Station panels.

Gooseneck mic gain

Sets the gain in dB for the gooseneck (panel) microphone in dB.

Note: Only available on V-Series and I-Station panels.

Speaker dim

This is to prevent howlround. When a talk selector is activated on a panel, the speaker volume is attenuated by the value set within speaker dim.

To change the setting select the box with the current setting to display the slider and use the mouse to drag the slider to the new setting. The speaker dim can be adjusted from 0dB to speaker off. The default is -6 dB.

Note: Only available on V-Series panels.

8.5.9 Audible alert options

These options apply to Concert, V-Series Panels and I-Station Panels.

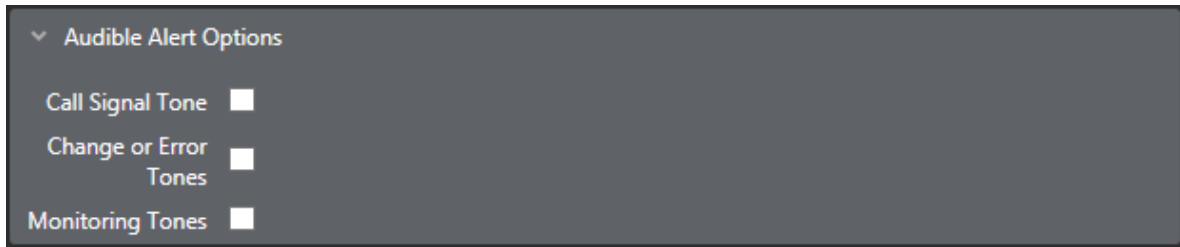

Figure 8-15 Audible Alert Options

The various configurable audible alerts on panels are as follows:

Call signal tone

When checked, the Call Signal Tone enables an audible tone when a call signal is received by the panel. The call signal can be used to signal an event on another panel. The default setting is disabled.

Change or error tones

When checked, the Change or Error Tones announce whenever the configuration for that panel has changed or when there is an error on the panel. When unchecked Change or Error Tones is disabled. The default setting is disabled.

Monitoring tones

When checked, enables the panel to emit a warning tone when another panel activates a listen to the first panel. If the box is unchecked the Monitoring tone is disabled. The default is disabled.

8.5.10 Tally options



Figure 8-16 Tally Options

The following Tally options are available:

Dimmed tallies

Enables dimmed Tally lights (the default is enabled). When enabled, keys will always show a dimmed state of the active state.

Note: V-Series panels only.

Inhibit amber tally

When enabled, prevents the tally light for Talk and Listen keys on V-Series panels from being lit **amber**. The tally light is only lit **red**.

Note: V-Series panels only.

In use tally

This allows the system to set a tally (flashing LED) on a panel key indicating that the port is currently in conversation with another panel or interface. The default is disabled.

Partyline Tally Brightness

Sets the brightness level for Partyline In Use Tallies on that panel. This can be set either dim or bright. The default value is dim.

Note: V-Series panels only.

Call Management Group In-Use Tally

Uses green LEDs to indicate that other groups are in active group-to-group calls.

Note: V-Series panels only.

Receiver Active Tally

When a two-way radio interface port is assigned to a talk selector, the red LED will flash once per second when that radio’s receiver is active. This tally must be enabled from the configuration program.

Note: FOR-22 only.

8.5.11 Fast key assign options

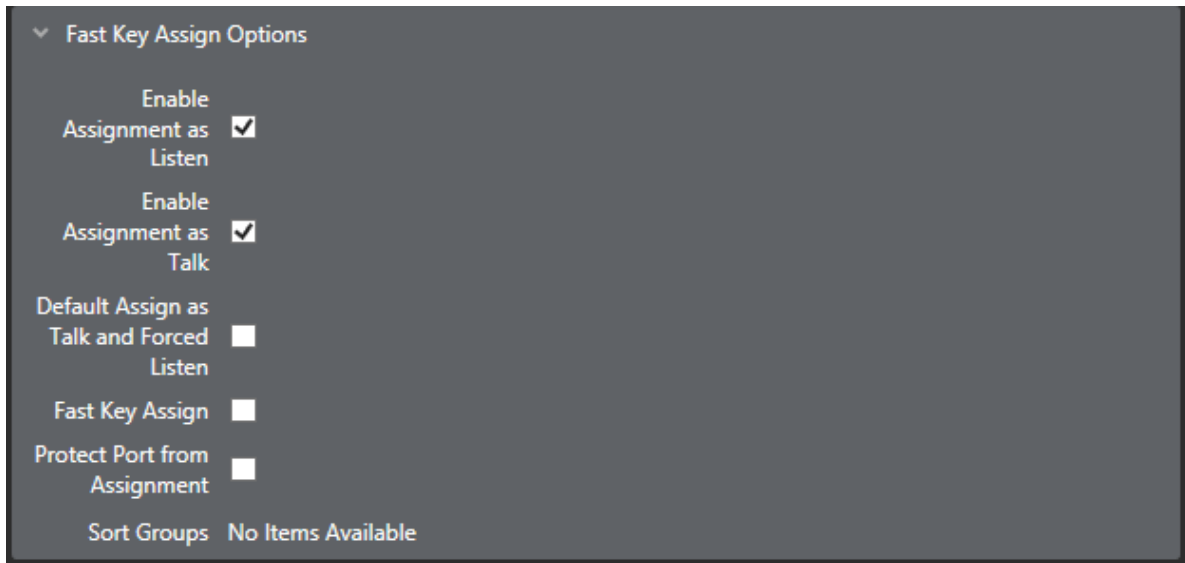

Figure 8-17 Fast Key Assign Options

Enable assignment as a listen

Enables the port to be assigned locally as a listen key by another panel. If it is set to False it prevents a listen key being assigned to the panel using local or fast key assignment.

The default is True.

Note: This functionality only takes effect when making assignments on a V-Series panel or Concert Panel.

Enable assignment as talk

Enables the port to be assigned locally as a talk key by another panel. If it is set to **False** it prevents a Talk key being assigned to the panel using local or fast key assignment.

The default is True.

Note: This functionality only takes effect when making local key assignments on a V-Series panel or a Concert panel.

Default assign as talk and forced listen

When enabled this forces any key assigned to this port to be a Talk and Forced Listen key. It is interlocked with the **Enable Assignment as Listen** and **Enable Assignment as Talk** settings so that whenever the **Default Assign as Talk and Forced Listen** setting is True both **Enable Assignment as Listen** and **Enable Assignment as Talk** are forced to the True state. If either or both of these settings is then changed to False the **Default Assign as Talk and Forced Listen** setting is automatically changed to False.

When this setting is False the **Enable Assignment as Listen** and **Enable Assignment as Talk** settings can be set normally.

The default setting is False.

Note: This functionality only takes effect when making assignments on a V-Series panel.

Fast key assign

Enables the panel for Fast Key Assign mode. This facility allows the panel operator to locally assign panel keys to local or remote ports by direct input of the port number into the dial pad. The panel operator can also assign keys directly from sort groups.

The Eclipse HX scalable dialcode scheme for Fast Key Assign is as follows:

`<matrix number><entity type><entity instance>`

For example, **Matrix 1 > Hardware ports > Port 1** would be dialled into the dial pad as 0101001.

The entity types are:

Entity	Number
Hardware port	01
Partyline	02
Fixed Group	03
IFB	04

Table 8-2 Fast Key Assign Entity types

Local fast key assign shortcut

If you are using Fast Key Assign on the local system, you do not have to enter the matrix type and entity type.

To use Fast Key Assign on a local system:

- 1) On the V-Series panel dial pad, select **#** to enter Fast Key Assign mode.

- 2) Enter the number of the port you want (for example, 001).
- 3) To validate the entry, select * on the dial pad.

Note: For more information about Fast Key Assign, see the **V-Series Panel Guide**.

Note: Fast Key Assign can only be used on V-Series panels with dial pads (numeric keypads).

Protect port from assignment

Prevents this port from being locally assigned by another panel using local key assign or fast key assign.

Sort groups

Opens a drop-down menu so that sort group memberships can be edited and applied. Once a sort group has been created, you can select which sort groups the panel has access to when making local key assignments.

Note: Not on Concert, AES Mono and Panel Aux.

8.5.12 Logic input options

These options apply only to V-Series and I-Station panels.

The screenshot displays the 'Logic Input Options' configuration interface. It features a list of four logic inputs, each with a dropdown menu for its function and a set of three dropdown menus for its action, destination, and action type. The current settings are as follows:

Logic Input	Function	Action	Destination	Action Type
Logic Input 1	No Function			
Logic Input 2	No Function			
Logic Input 3	Reply Key			
Logic Input 4	Exit Supervisor Mode			

Figure 8-18 Logic Input Options

The Logic Inputs are used with GPI connections on panels that are fitted with local option cards, and with V-Series panels.

The logic inputs are also associated with PTT function on headset 1 and headset 2 on V-Series panels where the headset is either an XLR-7 type headset connected to the front panel or a headset connected to the auxiliary audio connector. In the case of V-Series panels, headset 1 PTT 1 or headset 2 PTT 1 active has the same effect as Logic 1 active. Headset 1 PTT 2 or headset 2 PTT 2 active has the same effect as Logic 2 active.

The PTT actions for XLR-4 and XLR-5 headsets connected to a V-Series panel are determined by the **Headset PTT Function** setting. You can find this setting at **Hardware > Cards and Ports > Panel Options**.

The following actions are available for both Logic Input 1 and Logic Input 2:

- No Function
- Mic On/Off
- Mute Mic Output to Matrix
- Mic Off (Momentary)
- Activate Reply Key, then Clear Label
- Studio Announce
- Speaker Off
- Activate All Pre-Selected Talk Keys
- Activate Talk Switch 1
- Activate Talk Switch 2
- Listen Mode/Again
- Activate All Pre-Selected Two-Way Radio Talk Keys
- Activate Configured Action

The default setting is No Function.

Note: Logic Inputs 3 and 4 are only available on V-Series panels. Logic inputs 3 is pre-assigned to Reply Key. Logic input 4 is not currently used.

8.5.13 Attached control options

These options do not apply to ports configured as trunk.

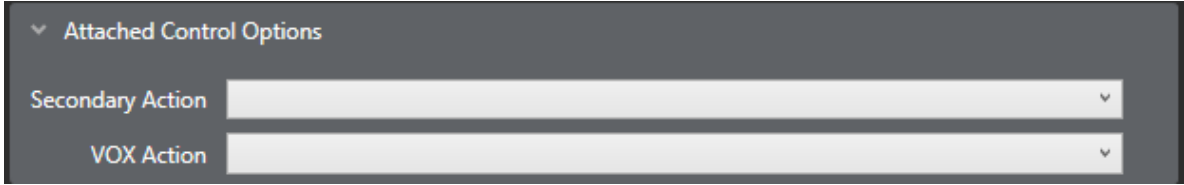

Figure 8-19 Attached Control Options

The Port Properties options for an Attached Control are as follows:

Secondary action

The Secondary action allows a Control to be attached to a Port. Whenever a talk route is made to the Port, the Control attachments such as Relays, Routes or Speed Dials, are activated.

Vox action

The VOX action allows a Control to be attached to a port. Whenever the audio level at the Port reaches the Audio Detection Threshold defined in Voice Operated Switch section of Advanced Settings the Control attachments such as Relays, Routes or Speed Dials, are activated.

Note: Not available on Concert panels.

8.5.14 DTMF options

These options apply to Direct, CCI-22, FOR-22, TEL-14 interfaces and LQ SIP.

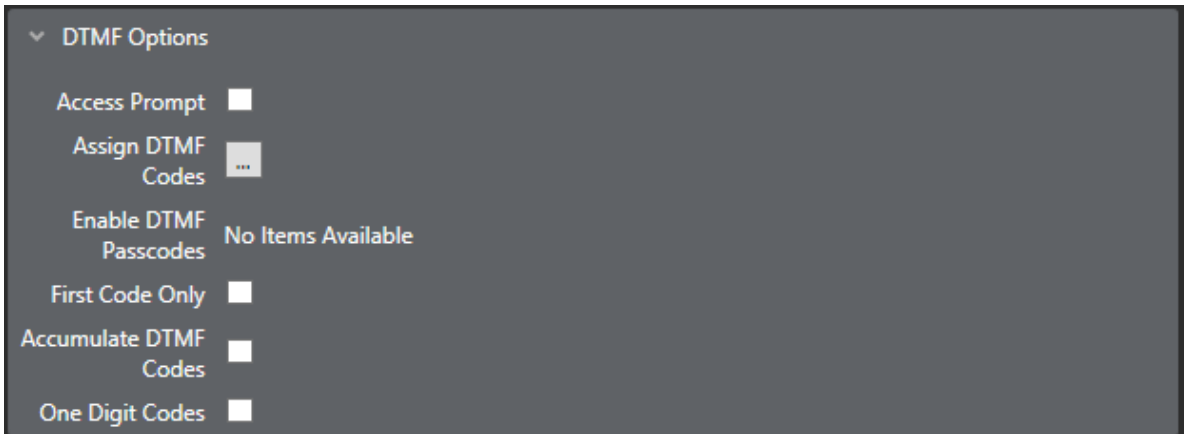

Figure 8-20 DTMF Options

This applies to all port types with the DTMF options, that is interfaces with a telephony element to them. They are also used to control access to the system by the external caller.

The setups for outgoing calls are configured on the MVX-A16 card which controls the outgoing DTMF on TEL-14 interface modules.

Access prompt

Controls whether the port sends DTMF access prompt tones and may be enabled or disabled. This allows the incoming caller to receive access prompts. The default is disabled.

Assign DTMF codes

Assigns a DTMF selector code to a specific audio path. This allows the incoming caller to make various preselected links within the matrix by entering a specific code.

Enable DTMF passcodes

This enables the use of passcodes that are set up using the **Configuration > Preferences > System Access Codes** tab. Up to eight DTMF passcodes can be set up for a system and each passcode can be enabled for a port using a drop-down menu.

When enabled incoming callers must enter a 4-digit passcode before being allowed access.

First code only

If this is enabled DTMF tone detection is disabled after the first valid DTMF code has been received. Default is disabled.

Note: Only on TEL-14.

Accumulate DTMF codes

This field controls whether only one DTMF selector code can be used (disabled) or whether multiple DTMF selector codes can be used. The default setting is disabled.

When enabled this allows the incoming caller to make multiple routes by dialling multiple codes.

One digit codes

If this is set enabled DTMF selector codes are limited to a single digit or the hash (#) and asterisk (*) characters. The default setting is disabled.

8.5.15 Auxiliary relay options

These options are only available on ports configured as Direct.



Figure 8-21 Auxiliary Relay Options

The Port Properties options for an Auxiliary Relay are as follows:

Has associated relay

The port device controls a relay (similar to secondary action).

For example, if an external device is connected to an MVX-A16 and that external device can control a relay the relay can be controlled through this setting.

8.5.16 Function Key Options

These options are only available on ports configured as V 32LD (32 Keys).

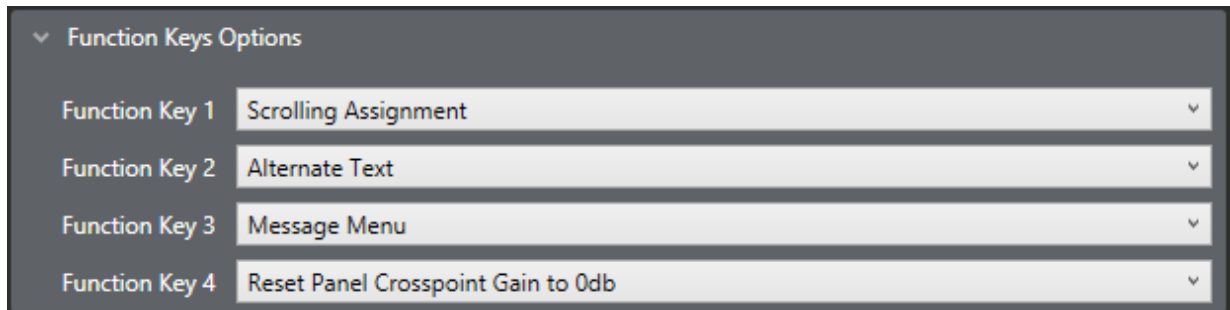

Figure 8-22 Function Key Options

Use these options to specify how the function keys on 32 key V-Series Lever panels operate. Figure 7.17 shows the default options.

For each of the four function keys (1 to 4), you can select from the following functions.

Function	Description	Function key LED behavior
Activate All Pre-Selected Talk Keys	When this option is selected, no configured audio routes are activated for latched keys until the associated function key is pressed (and held).	LED is on while the key is pressed.
Activate All Pre-Selected Two-Way Radio Talk Keys	When this option is selected, no configured audio routes to two-way radios are activated until the associated function key is pressed (and held).	LED is on while the key is pressed.
Activate Configured Action	This option allows the user to allocate a control sequence or macro to a function key. Use the EHX configuration software to generate control sequence.	LED is on while the key is activating the control sequence. Note: this is not the same as indicating when the control is active, if the control is activated via another means then the LED will not be lit.
Reset Panel Crosspoint Gains to 0dB	Opens the Reset Xpts (Yes/No) dialogue box. Selecting Yes resets the volume adjustment on all incoming audio sources to 0dB.	LED is on while the Reset Xpts menu is open.
Alternate Text	Enables/disables the Alt Text mode on the panel. Pressing this key will cause the key displays to show alternative text. Press the key again to return to standard text.	LED is on while the Alt Text mode is enabled.
Scrolling Assignment	When this option is selected, pressing the function key will result in all keys programmed with Sort Groups flashing. You can then use the up and down keys on the Keypad controls to scroll through group members. When a group member is visible in the key display, Talk and Listen to that member.	LED is on while Scrolling Assignment mode is enabled. Pressing the function key again will exit from scrolling assignment mode. This key has a 10 second timeout.
Supervisor	When this option is allocated to a function key, pressing the key will enable the first stage of Supervisor mode. See Supervise mode in the <i>Eclipse V-Series User Guide</i> .	LED is on while Supervise mode is enabled. To exit Supervise mode, press and hold the Menu key.

Message Menu	Access the menu that allows you to control message function options.	LED is on while the Message Menu is open.
--------------	--	---

Table 8-3 Function Key Options

9 Adding and configuring an E-QUE card

The E-Que card is used to connect wireless intercom systems such as FreeSpeak, CellCom and FreeSpeak II and for E1/T1 connection between matrices.

9.1 Adding an E-Que card (automatic discovery)

The E-Que card is automatically discovered when:

- You select the **Discover Hardware** option after the Matrix is placed on the **System Layout** from the discovery pane.
- You right-click a matrix on the **System Layout** screen, and then select **Configuration > Select New Configuration > Discover Hardware**.

9.2 Adding an E-Que card (manual)

To add an E-QUE card:

- 1) In **Hardware > Cards and Ports**, navigate to an available slot number (marked **Empty**). Do either of the following:
 - Double click the slot.
 - Right click the slot and select **Set Card Type**.
- 2) A drop-down menu is displayed, listing the available card types.

After you have added a card, you can move it to another card slot as follows:

- 1) Right-click the card slot to be moved, and select **Move Card**.
- 2) Right-click the required empty card slot, and select **Paste Card (Move)**.
The card moves to its new position.



Figure 9-1 Eclipse HX Empty Slots

- 3) Select one of the following E-QUE card options:
- E-QUE (E1 Direct)
 - E-QUE (T1 Direct)
 - E-QUE (E1 Trunk)
 - E-QUE (T1 Trunk)
 - E-QUE (E1 Direct/Trunk)
 - E-QUE (T1 Direct/Trunk)
 - E-QUE (Antenna)
 - E-QUE (Splitter)
 - E-QUE FS II-TA Antenna
 - E-QUE FS II-TA Splitter

Note: The E-QUE entry selected should be correct for the intended use as the cards are configured differently by EHX. You cannot have both E-QUE Antenna/Splitter and E-QUE FS II cards configured on the same matrix.

Note: The E-QUE card is a high-power device. For information about how many high-power devices you can install, see section **6.13 System hardware limits**.

Note: When you add or remove a card in your configuration, the following message appears:

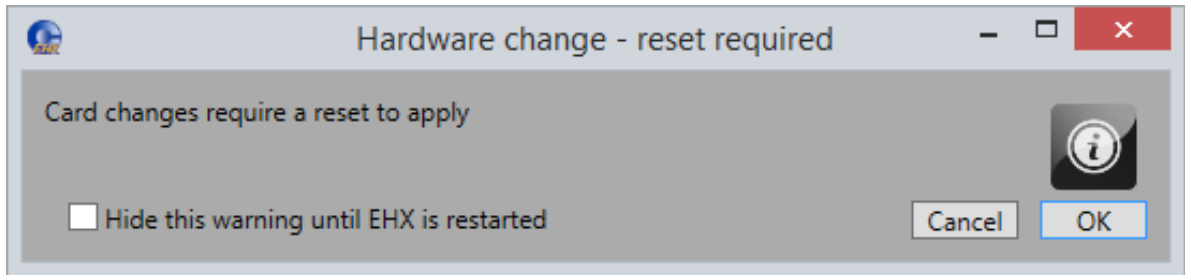

Figure 9-2 Hardware change

If your configuration contains linked matrices, the following message might appear when you apply changes to the matrix:

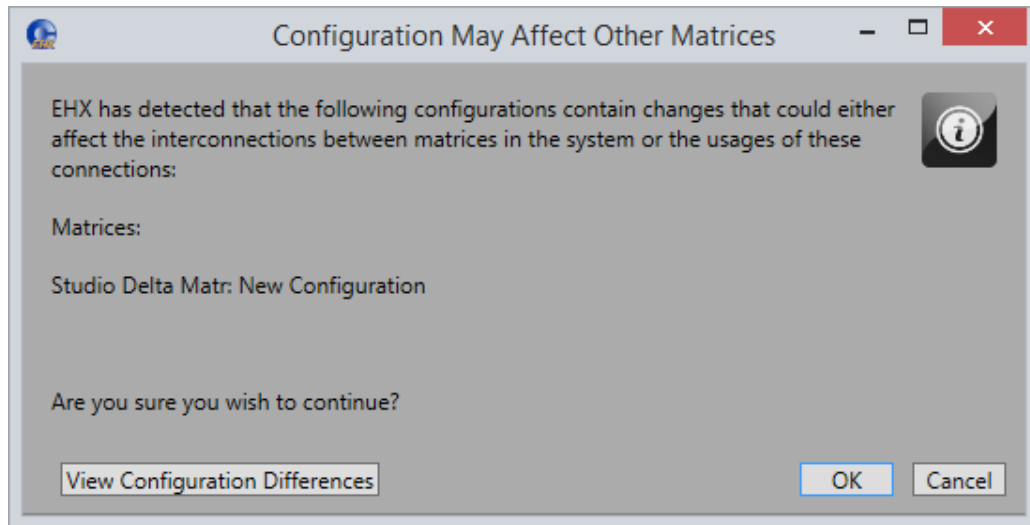

Figure 9-3 Configuration may affect other matrices

Click **View Configuration Differences** to see a list of possible interconnection issues.

- 4) Click **OK** to continue, or **Cancel**.

5) The **E-Que Card Properties** (for E1/T1 card types) screen appears

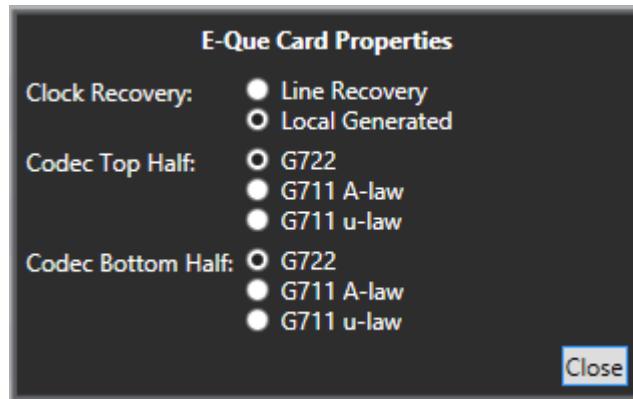

Figure 9-4 E-Que Card Properties

Do one of the following:

- To accept the default settings, click **Close**.
- Edit the **Clock Recovery**, **Codec Top Half** and **Codec Bottom Half**, and then click **Close**.

Note: For more information about Card Properties, see the relevant section for each type of E-Que card.

Note: To view and edit the E-Que card properties at any time, double click on the E-Que Card Slot or right-click and select **Card Properties**.

9.3 Removing an E-Que card

To remove an E-Que card from the configuration:

- 1) In **Hardware > Cards and Ports**, navigate to the slot number of the E-Que card you want to delete.
- 2) Right click the slot and select **Set Card Type**.
- 3) A drop-down menu is displayed, listing the available card types. Select **Empty**.
- 4) A warning dialog is displayed. To confirm the deletion, click **Yes**.

When you remove a card, the warning message (Hardware change – reset required) above might appear.

9.4 Setting the port function

To set the port function:

- 1) Click the **Port Function** field. A drop-down menu is displayed.
- 2) From the drop-down menu, select the desired configuration. Choices include:
 - Direct
 - Trunk

Note: The choice of port functions depends on which type of E-Que card is present.

Note: If you right-click on a port and select **Find Usages**, a list of other EHX entities which refer to the port is given.

9.5 E-QUE E1 direct

The E1 Direct is an E-QUE card that has been configured for 60 direct ports using E1 protocol. Each E1 port can be used as an E1 communication line to another E1 device. The following section provides guidance on configuring an E1 Direct in **Cards and Ports**.

9.5.1 Port function

This is always set to **Direct**.

9.5.2 Label

Label for the port used to assign the port to a path. The label has 10 characters, or can be split into two parts, each of maximum five characters.

9.5.3 Description

Optional port description, up to 255 characters long.

9.5.4 Card properties

For an E-QUE card in E1 Direct mode the Clock Recovery mode and Codec should be set by clicking on the **Card Properties** link in the lower right of the hardware display. This displays the Clock Recovery and Codec setup.

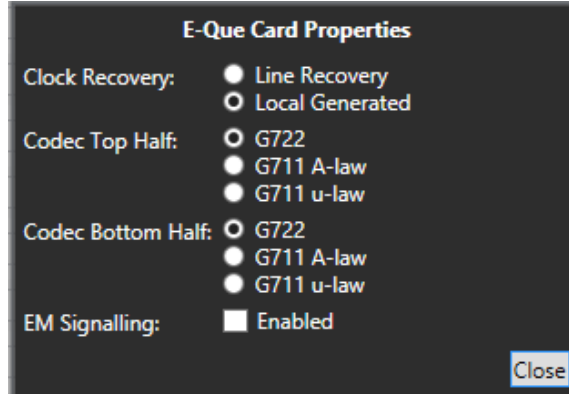

Figure 9-5 E1 Direct Card Properties Clock Recovery

The data clock may be generated by the E-QUE card (Local Generated) or taken from the E1 line. The clock source must be determined before configuration. Select the correct configuration by clicking on the appropriate radio button.

9.5.5 Codec

E-QUE cards configured as E1 Direct use two cat5 cables plugged into ports 1 (top) and 5 (bottom) for the E-QUE card to provide E1 ports. The top cable (Top Half) provides the first 30 ports (1-30) and the bottom cable (Bottom Half) provides the second 30 ports (31 - 60). The top and bottom cables can be configured to use different Codecs. The Codecs available are:

- G711 - standard G711 conversion and compression.
- G711 A-Law - uses an A-law algorithm to optimize the G711 codec. This is often used in European systems.
- G711 μ -Law - uses a μ -law algorithm to optimize the G711 codec. This is often used in North America and Japan.

Click on the appropriate radio button to select the codec for top and bottom cables.

E-Que rear panel connectors

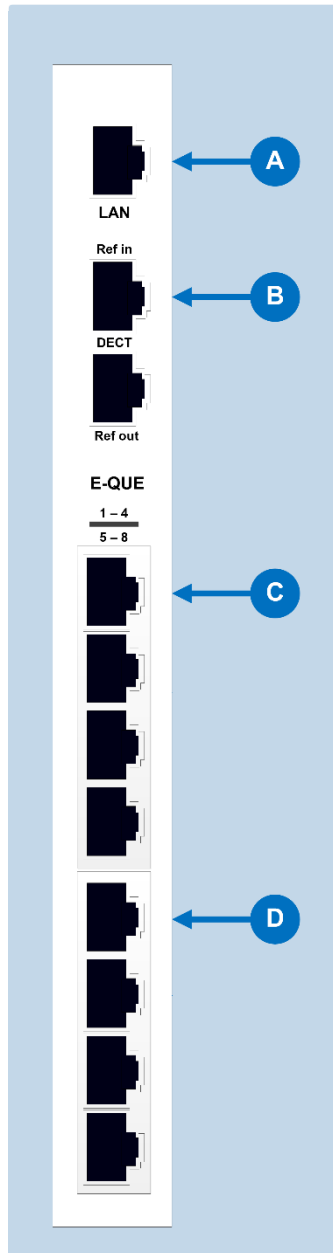

Figure 9-6: E-Que rear panel connectors

E-Que rear panel connectors	
A	LAN port (RJ-45) The LAN port is used for diagnostic purposes.
B	DECT sync ports (not used in the E1/T1 mode): DECT Ref in DECT Ref out
C	E1 / T1 Port 1 (RJ-45)
D	E1 / T1 Port 5 (RJ-45)

Table 9-1: Key to E-Que rear panel connectors

9.5.6 E & M Signalling

You can enable E & M Signalling by selecting the **Enabled** check box. E & M signalling is a standard for DC line signalling. For information about how to configure E & M signalling, see the **Eclipse HX Matrix Installation Guide**.

9.5.7 Port properties

To edit port properties, go to **Hardware > Cards and Ports**, and then select the required port. In the right-hand window, select the required property drop-down list. The following are available.

Menu item	Section
Basic Options	8.5.1 Basic Options
Voice Operated Switch Options	8.5.5 Voice operated switch (VOX) options
Global Options	8.5.6 Global options
Fast Key Assign Options	8.5.11 Fast key assign options
Gain Options	8.5.8 Gain Options
Tally Options	8.5.10 Tally options
Attached Control Options	8.5.13 Attached control options

Table 9-2 Port properties

9.6 E-QUE T1 direct

The T1 Direct is an E-QUE card that has been configured for 48 direct ports using T1 protocol. Each T1 port can be used as an T1 communication line to another T1 device. The following section provides guidance on configuring a T1 Direct in Cards and Ports.

9.6.1 Port function

This is always set to **Direct**.

9.6.2 Label

Label for the port used to assign the port to a path. The label has 10 characters, or can be split into two parts, each of maximum five characters.

9.6.3 Description

Optional port description, up to 255 characters long.

9.6.4 Card properties

For an E-QUE card in T1 Direct mode the Clock Recovery mode and Codec should be set by clicking on the **Card Properties** link in the lower right of the hardware display. This displays the Clock Recovery and Codec setup.

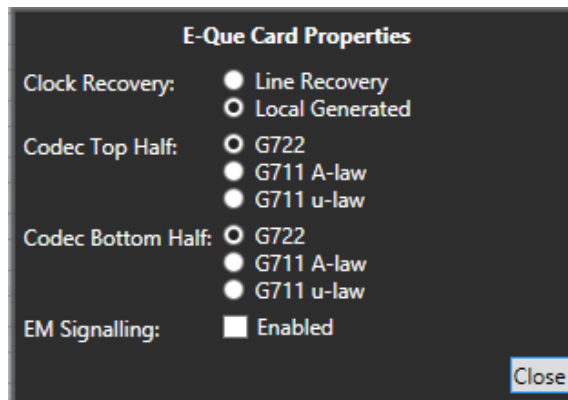

Figure 9-7 E1 Direct Card Properties Clock Recovery

The data clock may be generated by the E-QUE card (Local Generated) or taken from the T1 line. The clock source must be determined before configuration. Select the correct configuration by clicking on the appropriate radio button.

9.6.5 Codec

E-QUE cards configured as T1 Direct use two cables plugged into ports 1 (top) and 5 (bottom) for the E-QUE card to provide T1 ports. The top cable (Top Half) provides the first 24 ports (1-24) and the bottom cable (Bottom Half) provides the second 24 ports

(25 - 48). The top and bottom cables can be configured to use different Codecs. The Codecs available are:

- G711 - standard G711 conversion and compression.
- G711 A-Law - uses an A-law algorithm to optimize the G711 codec. This is often used in European systems.
- G711 μ -Law - uses a μ -law algorithm to optimize the G711 codec. This is often used in North America and Japan.

Click on the appropriate radio button to select the codec for top and bottom cables.

9.6.6 Port properties

To edit port properties, go to **Hardware > Cards and Ports**, and then select the required port. In the right-hand window, select the required property drop-down list.

The following are available.

Menu item	Section
Basic Options	8.5.1 Basic Options
Voice Operated Switch Options	8.5.5 Voice operated switch (VOX) options
Global Options	8.5.6 Global options
Fast Key Assign Options	8.5.11 Fast key assign options
Gain Options	8.5.8 Gain Options
Tally Options	8.5.10 Tally options
Attached Control Options	8.5.13 Attached control options

Table 9-3 Port properties

9.7 E-QUE E1 trunk

An E-QUE card set to E1 Trunk is used to connect Eclipse HX matrices using E1 trunking protocol. The System Ports display shows two ports numbered 1 and 31.

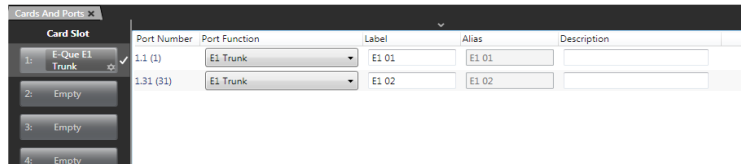

Figure 9-8 E1 Trunk Ports

Port 1 represents 30 virtual ports 1 - 30 which are allocated automatically for communications. Port 31 represents a further 30 virtual ports 31 - 60 that are automatically allocated.

9.7.1 Port function

This is always set to **E1 Trunk**.

9.7.2 Label

Label for the E1 direct port used to assign the port to a path. The label has 10 characters, or can be split into two parts, each of maximum five characters.

9.7.3 Description

Option port description up to 255 characters long.

9.7.4 Card properties

For an E-QUE card in E1 Trunk mode the Clock Recovery mode and Codec should be set by clicking on the **Card Properties** link in the lower right of the hardware display. This displays the Clock Recovery and Codec setup.

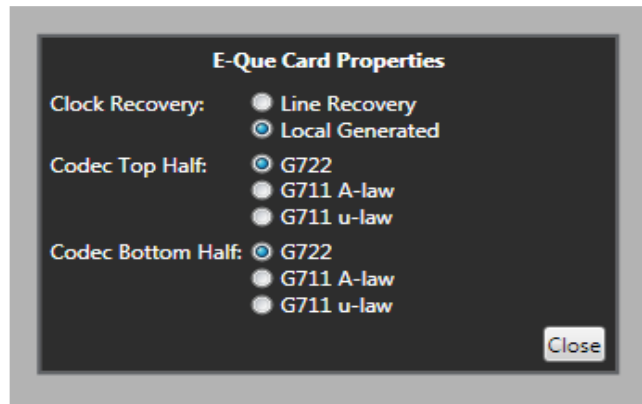

Figure 9-9 E1 Trunk Card Properties

9.7.5 Clock recovery

The data clock may be generated by the E-QUE card (Local Generated) or taken from the E1 line. Normally the card should be set to 'Line Recovery' for connection to a third-party device or E1 network. For other devices, the clock source must be determined before configuration. Select the correct configuration by clicking on the appropriate radio button.

If connecting two Eclipse HX matrices back to back using E1:

- An E1 crossover cable is required.
- One E-QUE card should be set to **Local Generated** clock and the other to **Line Recovery** clock.

9.7.6 Codec

E-QUE cards configured as E1 Trunk use two cables plugged into ports 1 (top) and 5 (bottom) for the E-QUE card to provide E1 trunk ports. The top cable (Top Half) provides the first 30 ports (1-30) and the bottom cable (Bottom Half) provides the second 30 ports (31 - 60). The top and bottom cables can be configured to use different Codecs.

The available Codecs comprise:

- G711 - standard G711 conversion and compression.
- G711 A-Law - uses an A-law algorithm to optimize the G711 codec. This is often used in European systems.
- G711 μ -Law - uses a μ -law algorithm to optimize the G711 codec. This is often used in North America and Japan.

Click the appropriate radio button to select the Codec for top and bottom cables.

9.7.7 E-Que E1 trunk basic settings

Note:

Port count

The port count specifies the number of virtual ports that are configured for the card. The port count (30 for E1, 24 for T1) is fixed.

Remote matrix

The remote matrix that the E1 trunk is connected to.

9.8 E-QUE T1 trunk

An E-QUE card set to T1 Trunk is used to connect Eclipse HX matrices using T1 trunking protocol. The System Ports display shows two ports numbered 1 and 25.

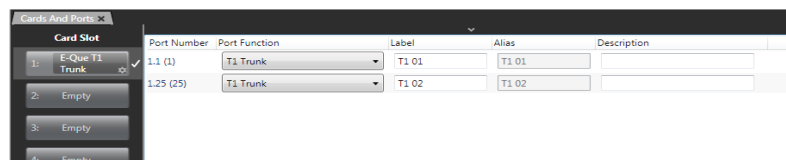

Figure 9-10 T1 Trunk Ports

Port 1 represents 24 virtual ports 1 - 24 which are allocated automatically for communications. Port 25 represents a further 24 virtual ports 25 - 48 that are automatically allocated.

9.8.1 Port function

This is always set to 'T1 Trunk'.

9.8.2 Label

Label for the port used to assign the port to a path. The label has 10 characters, or can be split into two parts, each of maximum five characters.

9.8.3 Description

Option port description up to 255 characters long.

9.8.4 Card properties

For an E-QUE card in T1 Direct mode the Clock Recovery mode and Codec should be set by clicking on the **Card Properties** link in the lower right of the hardware display. This displays the Clock Recovery and Codec setup.

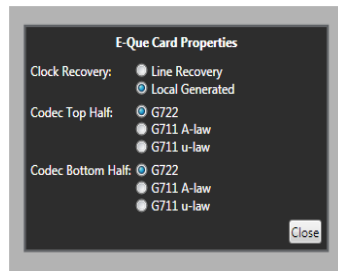

Figure 9-11 T1 Trunk Card Properties

9.8.5 Clock recovery

The data clock may be generated by the E-QUE card (Local Generated) or taken from the T1 line. Normally the card should be set to 'Line Recovery' for connection to a third-party device or a T1 network. For other devices, the clock source must be determined before configuration. Select the correct configuration by clicking on the appropriate radio button.

If connecting two Eclipse HX matrices back to back using T1:

- An E1 or T1 crossover cable is required.
- One E-QUE card should be set to **Local Generated** clock and the other to **Line Recovery** clock.

9.8.6 Codec

E-QUE cards configured as T1 Trunk use two cables plugged into ports 1 (top) and 5 (bottom) for the E-QUE card to provide T1 trunk ports.

The top cable (Top Half) provides the first 24 ports (1-24) and the bottom cable (Bottom Half) provides the second 24 ports (25 - 48). The top and bottom cables can be configured to use different Codecs. The Codecs that are available comprise:

- G711 - standard G711 conversion and compression.
- G711 A-Law - uses an A-law algorithm to optimize the G711 codec. This is often used in European systems.
- G711 μ -Law - uses a μ -law algorithm to optimize the G711 codec. This is often used in North America and Japan.

Click the appropriate radio button to select the Codecs for top and bottom cables.

9.8.7 E-Que trunk basic settings

Port count

The port count specifies the number of virtual ports that are configured for the card. The port count (24 for T1) is fixed.

Remote matrix

The remote matrix that the T1 trunk is connected to.

9.9 E-QUE E1 direct/trunk

The E1 Direct/Trunk is an E-QUE card that has been configured for 60 ports using E1 protocol. The first 30 are available to be set as E1 Directs, the second 30 are used for E1 trunk connection (and shown only as Port 31 - as on an E1 trunking card).

9.9.1 Port function

This is always set to Direct except for the last port which is set to Trunk.

9.9.2 Label

Label for the port used to assign the port to a path. The label has 10 characters, or can be split into two parts, each of maximum five characters.

9.9.3 Description

Option port description up to 255 characters long.

9.9.4 Card properties

For an E-QUE card in E1 Direct/Trunk mode, the Clock Recovery mode and Codec should be set by clicking on the **Card Properties** link in the lower right of the hardware display. This displays the Clock Recovery and Codec setup.

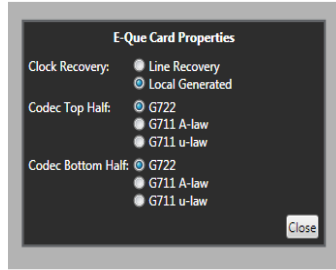

Figure 9-12 T1 Trunk Card Properties

9.9.5 Clock recovery

The data clock may be generated by the E-QUE card (Local Generated) or taken from the E1 line. Normally the card should be set to **Line Recovery** for connection to a third-party device or an E1 network. For other devices, the clock source must be determined before configuration. Select the correct configuration by clicking on the appropriate radio button.

If connecting two Eclipse HX matrices back to back using E1:

- An E1 crossover cable is required.
- One E-QUE card should be set to **Local Generated** clock and the other to **Line Recovery** clock.

9.9.6 Codec

E-QUE cards configured as E1 Direct/Trunk use two cables plugged into ports 1 (top) and 5 (bottom) for the E-QUE card to provide E1 trunk ports.

The top cable (Top Half) provides the first 16 ports (17-32) and the bottom cable (Bottom Half) provides the second 15 ports (33 - 48). The top and bottom cables can be configured to use different Codecs. The Codecs that are available comprise:

- G711 - standard G711 conversion and compression.
- G711 A-Law - uses an A-law algorithm to optimize the G711 codec. This is often used in European systems.
- G711 μ -Law - uses a μ -law algorithm to optimize the G711 codec. This is often used in North America and Japan.

Click the appropriate radio button to select the Codecs for top and bottom cables.

9.9.7 Port properties

To edit port properties, go to **Hardware > Cards and Ports**, and then select the required port. In the right-hand window, select the required property drop-down list.

The following are available.

Menu item	Section
Basic Options	8.5.1 Basic Options
Voice Operated Switch Options	8.5.5 Voice operated switch (VOX) options
Global Options	8.5.6 Global options
Fast Key Assign Options	8.5.11 Fast key assign options
Gain Options	8.5.8 Gain Options
Tally Options	8.5.10 Tally options
Attached Control Options	8.5.13 Attached control options

Table 9-4 Port properties

9.10 E-QUE T1 direct/trunk

The T1 Direct/Trunk is an E-QUE card that has been configured for 48 ports using T1 protocol. The first 24 are available to be set as T1 Directs, the second 24 are used for T1 trunk connection (and shown only as Port 25 - as on a T1 trunking card).

9.10.1 Port function

This is always set to Direct except for the last port which is set to Trunk.

9.10.2 Label

Label for the port used to assign the port to a path. The label has 10 characters, or can be split into two parts, each of maximum five characters.

9.10.3 Description

Option port description up to 255 characters long.

9.10.4 Card properties

For an E-QUE card in T1 Direct/Trunk mode, the Clock Recovery mode and Codec should be set by clicking on the **Card Properties** link in the lower right of the hardware display. This displays the Clock Recovery and Codec setup.

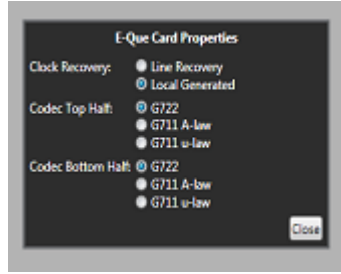

Figure 9-13 T1 Trunk Card Properties

9.10.5 Clock recovery

The data clock may be generated by the E-QUE card (Local Generated) or taken from the T1 line. Normally the card should be set to **Line Recovery** for connection to a third-party device or a T1 network. For other devices the clock source must be determined before configuration. Select the correct configuration by clicking on the appropriate radio button.

If connecting two Eclipse HX matrices back to back using T1:

- An T1 crossover cable is required.
- One E-QUE card should be set to **Local Generated** clock and the other to **Line Recovery** clock.

9.10.6 Codec

E-QUE cards configured as T1 Direct/Trunk use two cables plugged into ports 1 (top) and 5 (bottom) for the E-QUE card to provide T1 trunk ports.

The top cable (Top Half) provides the first 24 ports (1-24) and the bottom cable (Bottom Half) provides the second 24 ports (25 - 48). The top and bottom cables can be configured to use different Codecs. The Codecs that are available comprise:

- G711 - standard G711 conversion and compression.
- G711 A-Law - uses an A-law algorithm to optimize the G711 codec. This is often used in European systems.
- G711 μ -Law - uses a μ -law algorithm to optimize the G711 codec. This is often used in North America and Japan.

Click the appropriate radio button to select the Codecs for top and bottom cables.

9.10.7 Port properties

To edit port properties, go to **Hardware > Cards and Ports**, and then select the required port. In the right-hand window, select the required property drop-down list.

The following are available.

Menu item	Section
Basic Options	8.5.1 Basic Options
Voice Operated Switch Options	8.5.5 Voice operated switch (VOX) options
Global Options	8.5.6 Global options
Fast Key Assign Options	8.5.11 Fast key assign options
Gain Options	8.5.8 Gain Options
Tally Options	8.5.10 Tally options
Attached Control Options	8.5.13 Attached control options

Table 9-5 Port properties

9.11 E-Que antenna/E-Que FS II-TA antenna

Selecting this card type automatically configures an E-Que card with eight antenna ports (1 to 8 on the rear card). Each antenna provides five user ports and one control port. The hardware table shows the first user port number for each antenna rather than the E-Que port number. In the figure below the first antenna is shown as port 1 (the first antenna port) and the second antenna is shown as port 7 (previous first port number plus six), since beltpack ports 1-5 are on the first antenna. This is repeated for successive antennas.

Note: The E-Que card cannot power an antenna. The antennas require an external power source.

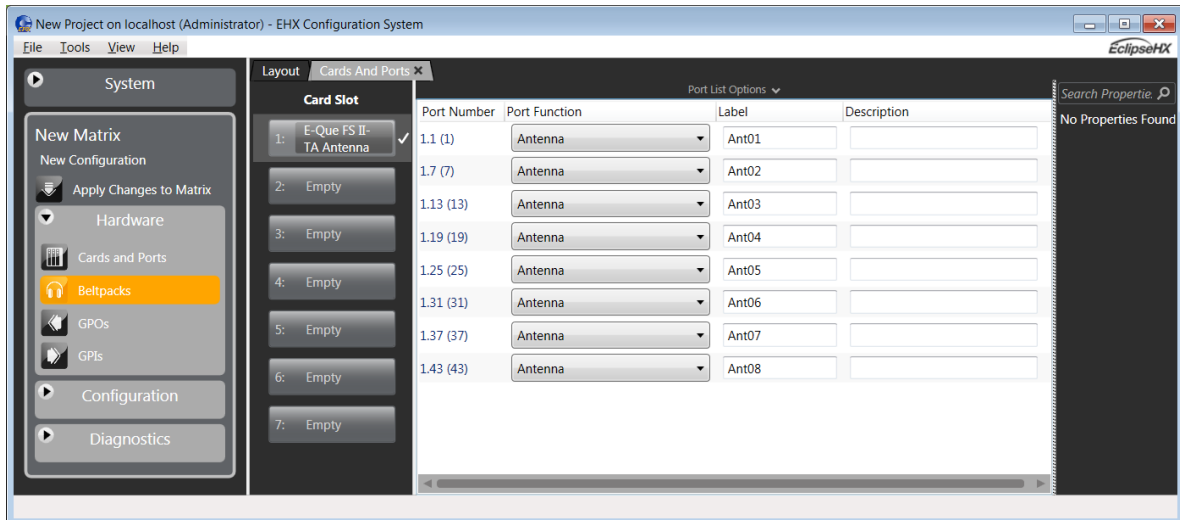

Figure 9-14 Antenna Ports

9.11.1 Port function

This is always set to **Antenna**.

9.11.2 Label

Used to differentiate between different Antennas. The label has 10 characters.

9.11.3 Description

An optional description for the port of up to 255 characters long.

9.12 Configuring the antenna on an E-Que card

- 1) To configure an Antenna on an E-Que card select the card in the **Hardware->Cards and Ports** list to display the configuration screen.

Each of the eight ports on the card is given a port number reflecting the total number of antenna connections that can be supported using the E-QUE card.

9.12.1 Antenna connections

The screenshot shows a configuration window titled 'Basic Options'. It contains four input fields: 'Cable Length' with a dropdown menu showing '0 - 129m', 'Comments' (empty), 'Description' (empty), and 'Label' with the text 'Ant01'.

Figure 9-15 E-Que Antenna Configuration

- 1) Select the card port to be configured and open **Basic Options** under **Port Properties** to set up the port parameters.

Cable length

- 1) To set the cable length between the card and the antenna select the **Cable Length** option and open the drop-down list. Adjust the cable length setting from 0 - 129 to 2860 - 2989.

The length set is displayed next to the option after carrying out a site survey.

Description

Enter an optional description for the antenna such as position or function.

Comments

A scratchpad for engineers to record any relevant information about the port or antenna.

Label

Labels for antennas are only used for diagnostics purposes, such as antenna/role correlation.

9.13 Configuring the antenna for an E-Que FS II card

- 1) To configure an E-Que FS II card for Antenna select the card on the hardware list to display the configuration screen.

Each of the eight ports on the card is given a port number reflecting the total number of antennas that can be supported using the E-Que FS II card.

9.13.1 Antenna connections

The screenshot shows a configuration window with a dark background. At the top, there is a dropdown menu labeled 'Basic Options' with a downward arrow. Below this, there are several input fields: 'Comments' (empty), 'Description' (empty), 'Label' (containing 'Ant01'), 'Cable Length Compensation' (containing '0 - 69m' and a downward arrow), and 'Antenna Group' (containing 'Antennas' and a three-dot menu icon).

Figure 9-16 E-Que FS II Antenna Configuration

- 1) Select the card port to be configured and open **Basic Options** under **Port Properties** to set up the port parameters.

9.13.2 Cable Length Compensation

This sets the amount of compensation applied to the antenna to account for different cable lengths in the system.

- 1) To set the cable length between the card and the antenna select the **Cable Length** option and open the drop-down list. Adjust the cable length setting from 0 - 69 to 1540 - 1609.

The length set is displayed next to the option after carrying out a site survey.

9.13.3 Description

Enter an optional description for the antenna such as position or function.

9.13.4 Comments

A scratchpad for engineers to record any relevant information about the port or antenna.

9.13.5 Label

Listen labels for antennas are only used for diagnostics purposes, such as antenna/role correlation.

9.13.6 Antenna Group

Select an antenna group for DECT synchronization.

9.14 E-Que splitter/E-Que FS II-TA splitter

This option automatically adds an E-Que card with two splitter ports (1 and 5 on the rear card) configured. Each splitter can support up to five antennas and each antenna provides five beltpack ports. The hardware table shows ten antennas with the first port number for each antenna rather than the E-Que port number.

Therefore, the first antenna is shown as port 1 (the first antenna connection) and the second antenna is shown as port 7 (previous first port number plus six), since ports 1-6 are on the first antenna. This is repeated for successive antennas.

Card Slot	Port Number	Port Function	Label	Alias	Description
1: E-Que Splitter	1.1 (1)	Antenna	Ant01	Ant01	
2: Empty	1.7 (7)	Antenna	Ant02	Ant02	
3: Empty	1.13 (13)	Antenna	Ant03	Ant03	
4: Empty	1.19 (19)	Antenna	Ant04	Ant04	
5: Empty	1.25 (25)	Antenna	Ant05	Ant05	
6: Empty	1.31 (31)	Antenna	Ant06	Ant06	
7: Empty	1.37 (37)	Antenna	Ant07	Ant07	
8: Empty	1.43 (43)	Antenna	Ant08	Ant08	
	1.49 (49)	Antenna	Ant09	Ant09	
	1.55 (55)	Antenna	Ant10	Ant10	

Figure 9-17 Splitter Ports

9.14.1 Port function

This is always set to Antenna.

9.14.2 Label

Used to differentiate between different Antennas. The label has 10 characters.

9.14.3 Description

An optional description for the port of up to 255 characters long.

9.15 Configuring an E-Que card for splitter

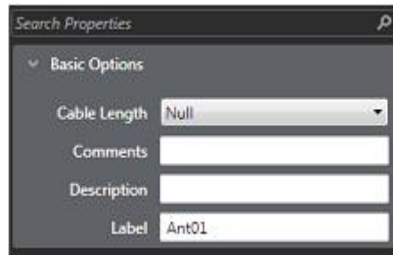

Figure 9-18 E-QUE Splitter Configuration

- 1) Select the card port to be configured and go to **Port Properties > Basic Options** to set up the port parameters.

9.15.1 Cable length

- 1) To set the cable length between the card and the antenna select the **Cable Length** option and open the drop-down list. Use the mouse to adjust the cable length setting from 0 - 129 to 2860 - 2989.

The length set is displayed next to the option after carrying out a site survey.

9.15.2 Description

Enter an optional description for the antenna such as position or function.

9.15.3 Engineer comments

A scratchpad for engineers to record any relevant information about the port or antenna.

9.15.4 Label

Label for the port used to assign the port to a path. The label has 10 characters, or can be split into two parts, each of maximum five characters.

- 1) To configure an E-Que card for Splitters select the card on the hardware list to display the configuration screen.

In this case ten antennas are displayed corresponding to the two splitters that can be connected to an E-Que card with each splitter supporting up to five antennas.

9.16 Configuring an E-Que FS II card for splitter

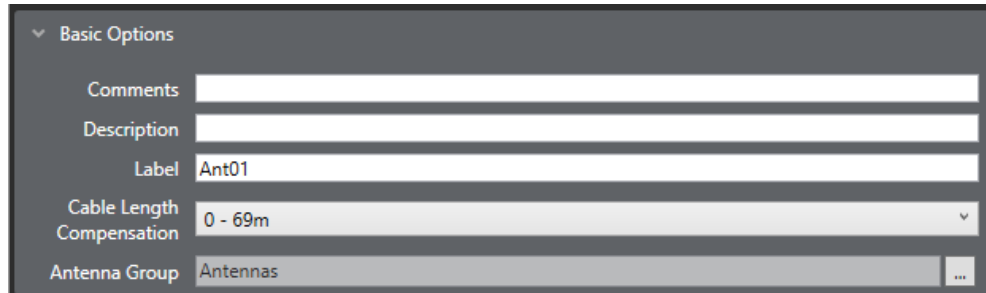

The screenshot shows a configuration window titled 'Basic Options'. It contains several input fields: 'Comments' (empty), 'Description' (empty), 'Label' (filled with 'Ant01'), 'Cable Length Compensation' (a dropdown menu showing '0 - 69m'), and 'Antenna Group' (a dropdown menu showing 'Antennas').

Figure 9-19 E-Que Antenna Configuration

- 1) Select the card port to be configured and go to **Port Properties > Basic Options** to set up the port parameters.

9.16.1 Cable length compensation

- 1) To set the cable length between the card and the antenna select the **Cable Length** option and open the drop-down list. Use the mouse to adjust the cable length setting from 0 - 69 to 1540 - 1609.

The length set is displayed next to the option after carrying out a site survey.

9.16.2 Description

Enter an optional description for the antenna such as position or function.

9.16.3 Comments

A scratchpad for engineers to record any relevant information about the port or antenna.

9.16.4 Label

Label for the port used to assign the port to a path. The label has 10 characters. To configure an E-Que card for Splitters select the card on the hardware list to display the configuration screen.

In this case ten antennas are displayed corresponding to the two splitters that can be connected to an E-Que card with each splitter supporting up to five antennas.

9.17 Antenna role map for FreeSpeak/CellCom

Select **Diagnostics > Antenna Roles** to display the status of the FreeSpeak/CellCom antennas and roles currently configured.

Antenna/Role Map x		Roles									
		Role1	Role2	Role3	Role4	Role5	Role6	Role7	Role8	Role9	Role10
Ant01											
Ant02											
Ant03											
Ant04											
Ant05											
Ant06											
Ant07											
Ant08											
Ant09											
Ant10											

Figure 9-20 Antenna and Role Display

The mapping of roles onto antennas is indicated by the colored squares. When a role is registered to an antenna, a black dot is placed in the antenna row at the role position.

9.18 Antenna role map for FreeSpeak II™

Select **Diagnostics > Antenna Roles** to display the status of the FS-II antennas and roles currently configured, and the antenna groups.

Figure 9-21 Antenna and Role Display

10 Adding and configuring an IVC-32 card

The IVC-32 card enables you to connect Eclipse HX matrices to, for example, Concert panels, IP enabled V-Series panels, LQ devices and Agent-IC Mobile Client over a LAN, WAN or Internet using IP.

Note: You can also centrally manage IVC-32 cards using the IP Devices option. Go to **Hardware > IP Devices**. See section **22 IP devices**.

10.1 Adding an IVC-32 card (automatic discovery)

The IVC-32 card is automatically discovered when:

- You select the **Discover Hardware** option after the Matrix is placed on the **System Layout** from the discovery pane.
- You right-click a matrix on the **System Layout** screen, and then select **Configuration > Select New Configuration > Discover Hardware**.

10.2 Adding an IVC-32 card (manual)

To add an IVC-32 card:

- 1) In **Hardware > Cards and Ports**, navigate to an available slot number (marked **Empty**). Do either of the following:
 - Double click the slot.
 - Right click the slot and select **Set Card Type**.

A drop-down menu is displayed, listing the available card types. Select **IVC-32** or **IVC-32 (Redundant)**.

Note: The IVC-32 card is a high-power device. For information about how many high-power devices you can install, see section **6.13 System hardware limits**.

Note: An IVC-32 card can be in redundant mode. If you select **IVC-32 (Redundant)**, the card will operate as a redundant card, and you will not be able to configure any ports on this card.



Figure 10-1 IVC-32 Card Selection

When you add or remove card to the matrix configuration, the following screen might appear unless the **Hide this warning until EHX is restarted** option has been selected:

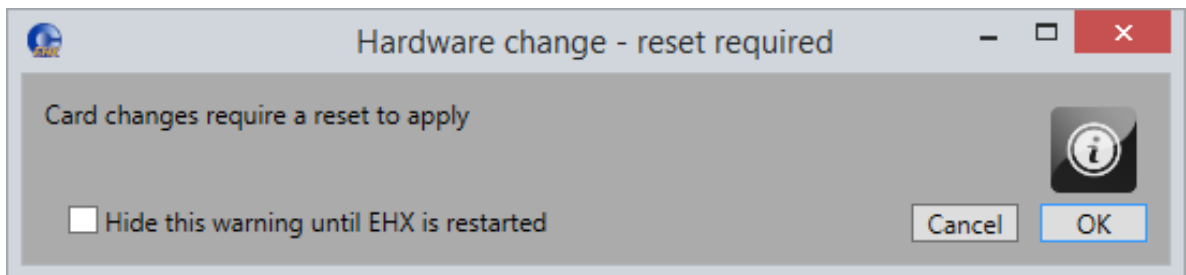

Figure 10-2 Hardware change

Click **OK** to continue.

If your configuration contains linked matrices, the following message might appear when you try to apply changes to the matrix:

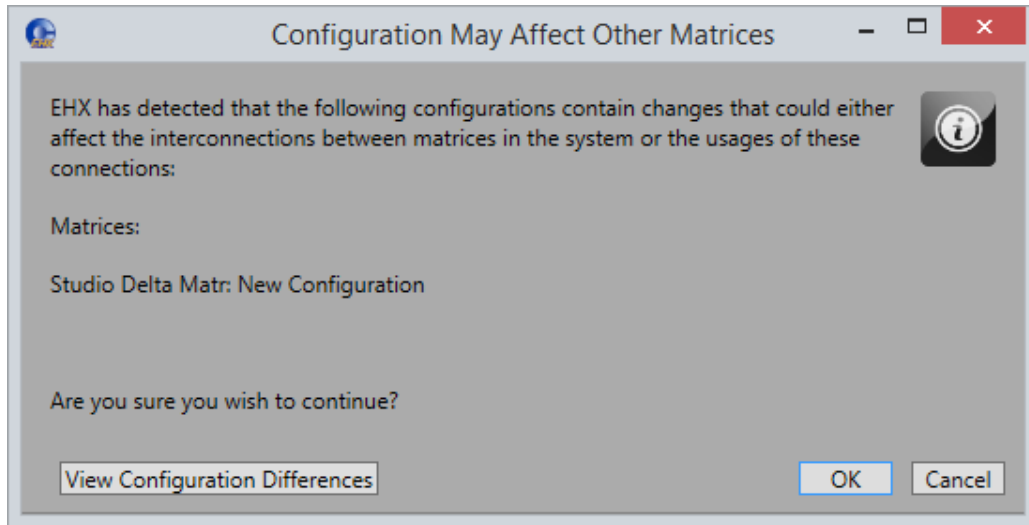

Figure 10-3 Configuration may affect other matrices

- 2) Click **View Configuration Differences** to see a list of possible interconnection issues.
- 3) Click **OK** to continue, or **Cancel**.
- 4) The **IVC-32 Card Properties** screen appears

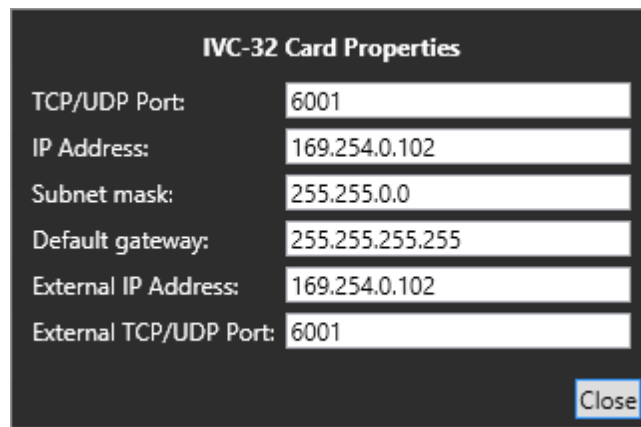

Figure 10-4 IVC-32 Card Properties

Do one of the following:

- To accept the default settings, click **Close**.
- Change the edit fields as required, and then click **Close**.

Note: To view and edit the IVC-32 card properties at any time, double click on the IVC-32 Card Slot or right-click and select **Card Properties**.

After you have added a card, you can move it to another card slot as follows:

- 1) Right-click the card slot to be moved, and select **Move Card**.
- 2) Right-click the required empty card slot, and select **Paste Card (Move)**.

The card moves to its new position.

10.2.1 Setting IVC-32 card properties

General

Default ports used by the Eclipse HX system are 6001 for IP Panel communications, 42001 for EHX communications and 1300 for the matrix event log. Ports 42001 and 1300 are used by the UDP protocol.

Ports 42001 and 1300 are not user adjustable.

Port 6001 is user adjustable.

Eclipse HX system administrators are advised to check with network administrators or IT that these default ports may be used without causing a conflict with any other application on the network.

Each IVC-32 card requires a static IP address. It is recommended that these addresses are issued by IT or the Network Administrator to avoid conflicts with any other system on the network and are not part of the DHCP dynamically assigned range.

TCP/UDP Port

Sets the TCP/UDP port number to be used by the IVC-32 card when communicating over IP. This parameter should not normally be changed from the default value unless all the IP devices are also updated to use the new port number. If this is not done the IP end devices cannot communicate with the IVC-32 card.

Eclipse HX system administrators are advised to check with network administrators or IT that the default port may be used without causing a conflict with any other application on the network.

If the IP port number is changed ports 42001 and 1300 should not be used as these ports are already used by EHX. The Eclipse HX system administrator should check with the network administrator or IT to obtain a port number to use.

IP address

This is the static IP address of the IVC-32 card, assigned by IT or the Network Administrator. This is used by IP devices to communicate with the matrix via the IVC-32 card.

Note: It is important to ensure that the IVC-32 card IP address does not clash with any other IP address on the network (another device using the same IP address). If there is an IP address clash the IVC-32 card may repeatedly lose

the connection with IP devices. If the IVC-32 card IP address clashes it may also cause the IVC-32 card to reset.

It is recommended that the IVC-32 is given a static IP address. The V-Series panels, Concert clients and Agent-IC Mobile Client IP addresses can be assigned by a DHCP server.

Subnet mask

This is the subnet mask used by the IVC-32 card to define the address range the card can access. Typically, this is assigned by IT or the Network Administrator.

Default gateway

This is the address of the gateway (router) to be used to communicate with external devices such as IP panels and Concert clients over a wider IP network. This address is optional but if used must fall within the address range defined by the subnet mask.

External IP address

If the Matrix is operating behind a firewall, then port address forwarding can be used to expose a LAN-connected device to the outside world. Typically, this is assigned by IT or the Network Administrator.

This IP address must be manually entered on IP panels to communicate directly with the IVC-32 card. This address must be a unique address on the internet. It is not affected by the subnet mask.

External TCP/UDP port

This is the TCP/UDP port used when communicating directly with the IVC-32 card using the External IP address. The default port number is 6001 and this should not be changed unless the default port number on all external devices is also changed to the new port number.

10.3 Removing an IVC-32 card

To remove an IVC-32 card from the configuration:

- 1) In **Hardware > Cards and Ports**, navigate to the slot number of the IVC-32 card you want to delete.
- 2) Right click the slot and select **Set Card Type**.
- 3) A drop-down menu is displayed, listing the available card types. Select **Empty**.
- 4) A warning dialog is displayed. To confirm the deletion, click **Yes**.

When you remove a card, the warning message (Hardware change – reset required) above might appear.

10.4 Setting the port function

To set the port function:

- 1) Click the **Port Function** field. A drop-down menu is displayed.
- 2) From the drop-down menu, select the desired device (user panels and interfaces that may be connected to the port).

The available device types are listed below:

- Concert panel
- Direct
- Empty
- Hosted Direct
- LQ
- LQ SIP
- LQ Trunk
- Mobile Client
- Trunk
- V 1RU Lever
- V 1RU Push
- V 1RU Rotary
- V 2RU Lever (24 keys)
- V-2RU Lever (32 keys)
- V 2RU Push
- V 2RU Rotary
- V Desktop Lever
- V Desktop Push
- V Desktop Rotary

Note: If you right-click on a port and select **Find Usages**, a list of other EHX entities which refer to the port is given.

If you add an IP-enabled V-Series panel, the following screen appears:

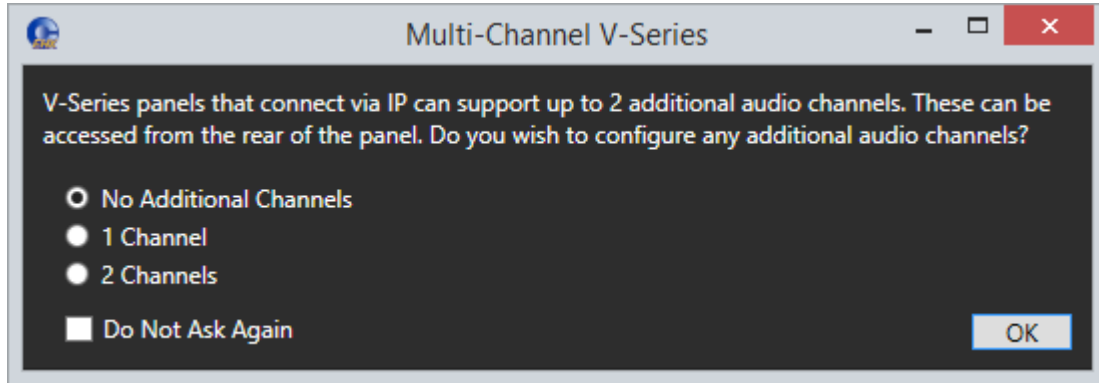

Figure 10-5 Multi-Channel V-Series

Select the number of additional channels you require. If you select one or two additional channels, these channels automatically appear as **Hosted Direct** in the **Port Function** column of the **Cards and Ports** screen, for example:

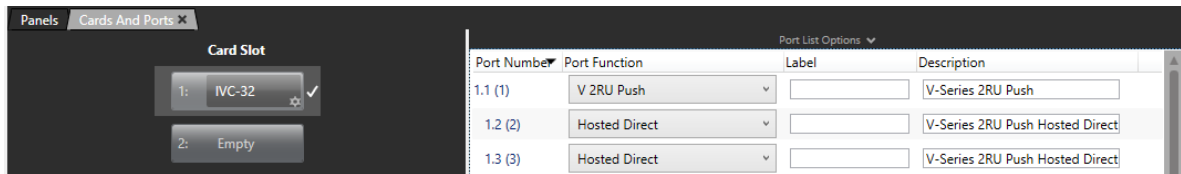

Figure 10-6 Two Hosted Direct sub-channels

If you add an LQ port, a GPO is added to the EHX configuration. This appears in **Hardware > GPOs**, and in the **Interface relays** tab of **Configuration > Controls**.

Note: Hosted direct ports are indented from their host ports in the **Cards & Ports** screen.

10.5 Port Properties

To edit port properties, go to **Hardware > Cards and Ports**, and then select the required port. In the right-hand window, select the required property drop-down list. The following are available.

Menu item	Section
Basic Options	8.5.1 Basic Options
Panel Options	8.5.2 Panel options
Assignment Panel Options	8.5.3 Assignment panel (AP) options
Menu Options	8.5.4 Menu options
Voice Operated Switch Options	8.5.5 Voice operated switch (VOX) options
Global Options	8.5.6 Global options
Audible Alert Options	8.5.9 Audible alert options
IP Port Options	10.5.2 IP port options
Fast Key Assign Options	8.5.11 Fast key assign options
Telephone Options	8.5.7 Telephone options
Gain Options	8.5.8 Gain Options
Tally Options	8.5.10 Tally options
Logic Input Options	8.5.12 Logic input options
Attached Control Options	8.5.13 Attached control options

Table 10-1 Port properties

10.5.1 Parent port

Note: The Parent Port option is only available with the IVC-32 card when **Port Function** is set to **Hosted Direct**. This setting indicates which IVC32 port (on the same card) is the port number of the hosting V-Series panel.

For a Hosted Direct sub channel, you can select a parent port for the Hosted Direct sub channel. This sub-channel is always grouped with the parent port. If you sort the list of ports according to Port Number, each sub-channel is listed with its parent port.

To select a parent port:

- 1) Select **Hardware > Cards and Ports**, and then select the required port. In the right-hand window, select **Basic Options**.
- 2) Select a parent port from the drop-down list.

10.5.2 IP port options

Note: IP Port Options are only available for ports on IVC-32 cards that are not Hosted Direct.

UserID

ID required for the port to log in to the system via the IVC-32 card. The user ID is set in EHX and entered at the other end of the link. The User ID field must be unique for each port in the linked set of configurations.

Note: The UserID is 10 characters long (including spaces) and is case sensitive.

Network connection

Selects the network connection type for battan IP connection. Select from LAN (high speed), WAN (intermediate) or Internet (low speed) from a drop-down menu. The default setting is LAN.

Audio codec

Allows the codec (G.722) to be selected for IP connections.

Password

Panel password required for the port to log in to the system via the IVC-32 card. The password is set in EHX and entered at the other end of the link.

Note: The Password is 10 characters long (including spaces) and is case sensitive. The password field can be left blank for convenience if security is not a concern.

VOIP caller

Enables the port as the initiator of the VOIP setting.

Note: Only available on IP Trunks and IP Directs.

Remote IP address

The IP address for the remote device

Note: Only available on IP Directs.

UDP comm. port

The UDP communication port for the remote device.

Note: Only available on IP Directs.

Remote user ID

The unique user ID for the remote device. The maximum length for a user ID is ten characters including spaces.

Note: The Password is 10 characters long (including spaces) and is case sensitive.

Note: Only available on IP Directs.

Remote password

The password for the remote device. The maximum length for the password is ten characters including spaces.

Note: The Password is 10 characters long (including spaces) and is case sensitive.

Note: Only available on IP Directs.

10.6 Adding and configuring an IVC-32 redundant card

You can add an IVC-32 Redundant Card to provide fail-over redundancy for one or more IVC-32 Cards in the matrix. You cannot add an IVC-32 redundant card if you do not already have at least one IVC-32 card present.

- 1) In **Hardware > Cards and Ports**, navigate to an available slot number (marked **Empty**). Do either of the following:
 - Double click the slot.
 - Right click the slot and select **Set Card Type**.

A drop-down menu is displayed, listing the available card types. Select **IVC-32 (Redundant)**.

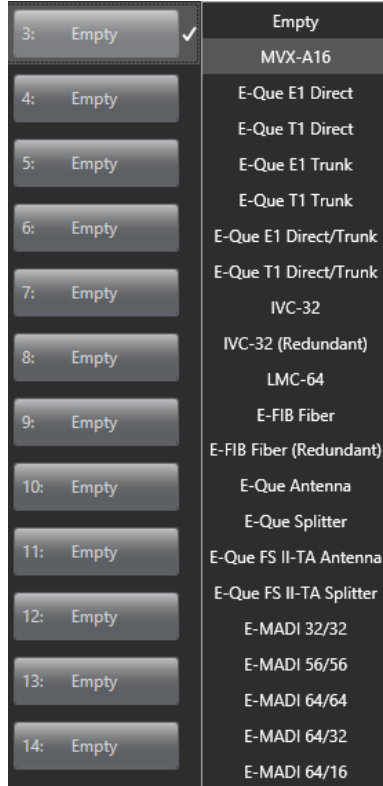

Figure 10-7 IVC-32 Card Selection

When you add or remove card to the matrix configuration, the following screen might appear unless the **Hide this warning until EHX is restarted** option has been selected:

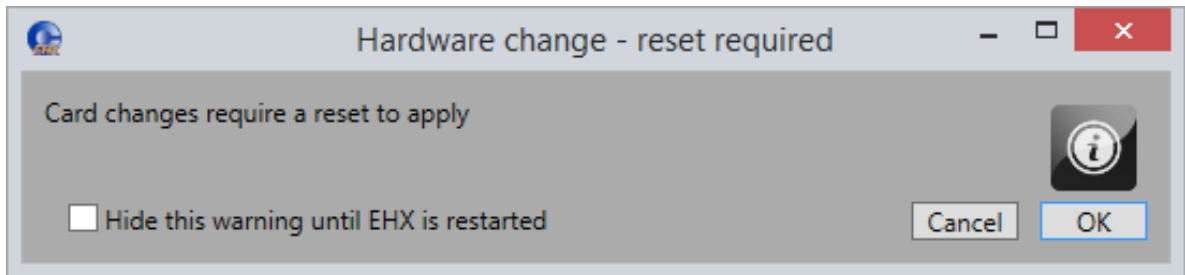

Figure 10-8 Hardware change

Click **OK** to continue.

If your configuration contains linked matrices, the following message might appear when you try to apply changes to the matrix:

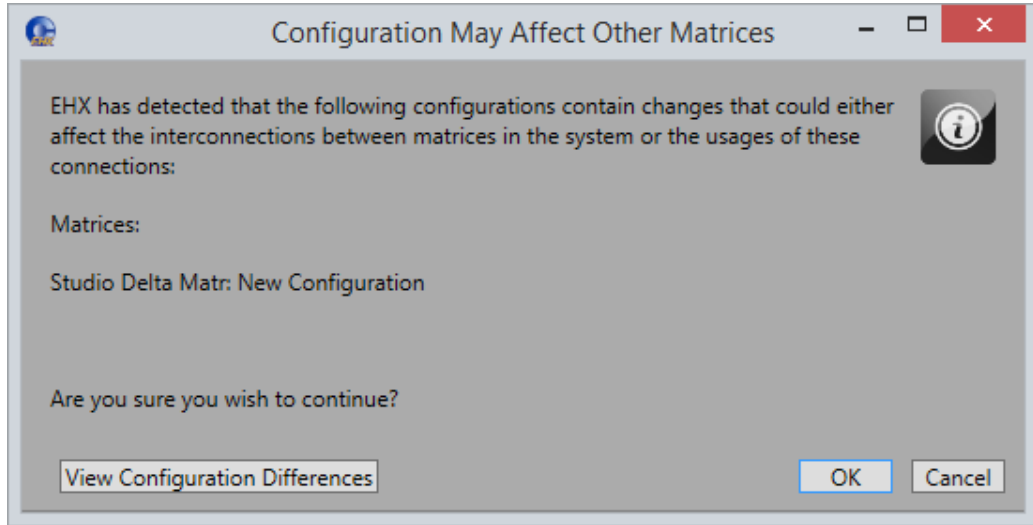

Figure 10-9 Configuration may affect other matrices

- 2) Click **View Configuration Differences** to see a list of possible interconnection issues.
- 3) Click **OK** to continue, or **Cancel**.

Note: You can only configure IVC-32 redundant cards up to the maximum number of IVC-32 Cards supported by the matrix.

Note: The IVC-32 Redundant card is a high-power device. For information about how many high-power devices you can install, see section **6.13 System hardware limits**.

- 4) The card properties screen appears. This allows you to specify which IVC-32 card to provide redundancy for:

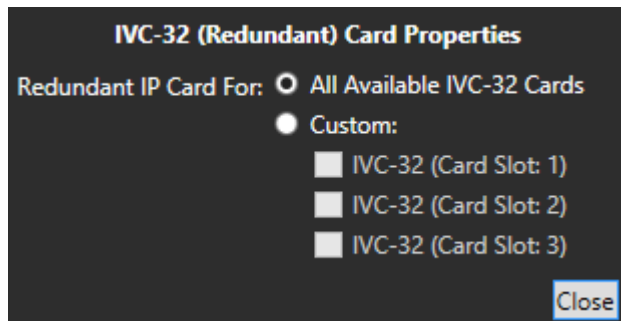

Figure 10-10 IVC-32 (Redundant) Card Properties

Do one of the following:

- To accept the default settings, click **Close**.
- Change the edit fields as required, and then click **Close**.

Note: To view and edit the IVC-32 card properties at any time, double click on the IVC-32 Card Slot.

10.6.1 Combinations of IVC-32 cards

The following combinations of IVC-32 Cards and IVC-32 Redundant Cards are possible:

- One IVC-32 Card and one IVC-32 Redundant Card - the redundant card provides backup for the only card in the system
- Two IVC-32 Cards and one IVC-32 Redundant Card - you can either set the redundant card to provide redundancy backup for both IVC-32 Cards in event of failure, or specify that it is only backing up particular cards.
- Two IVC-32 Cards and two IVC-32 Redundant Cards - you must specify which redundant card is providing redundancy for which IVC-32 card. It is not possible to have two redundant cards providing backup for the same IVC-32 Card.
- Three IVC-32 Cards and one redundant card - you can either set the redundant card to provide redundancy backup for all three IVC-32 Cards in event of failure, or specify that it is only backing up a particular card.

An IVC-32 Card will fail-over to the IVC-32 Redundant Card under the following conditions:

- All configured VoIP ports are unconnected for longer than 90 seconds.
- The IVC-32 Card is detected as absent from the VME backplane.

When a failover is detected, the following steps occur:

- 1) The Config card checks to see if there is a redundant card configured to take over from the failed card. If not then the card is placed into an error state and nothing else happens.
- 2) If a redundant card is configured, then the failed card is placed into an error state.
- 3) All port numbers and timeslots are turned over to the redundant card.
- 4) The failed card has its IP details cleared. The IP address is changed to 169.254.0.<slotNum> and resets.
- 5) The redundant card takes on the failed card's previous IP address and resets.

- 6) On startup the redundant card is placed into the Initialising state and finally into the Running States.
- 7) The failed card stays in the Error state.
- 8) The redundant card now establishes all VoIP calls that were previously configured on the failed card.

Once the switch over process has started the redundant card starts accepting and making VoIP connections within 40 seconds.

10.6.2 Switch-back

A switch back from a redundant card back to a failed card only occurs under the following condition:

The redundant card has failed. If the original card is still in error, then it will switch back and forward until corrective action is taken.

11 Adding and Configuring an LMC-64 card

The LMC-64 card allows Eclipse HX matrices to provide audio level metering data to Dynam-EC clients over an IP network.

11.1 Adding an LMC-64 card (automatic discovery)

The LMC-64 card is automatically discovered when:

- You select the **Discover Hardware** option after the Matrix is placed on the **System Layout** from the discovery pane.
- You right-click a matrix on the **System Layout** screen, and then select **Configuration > Select New Configuration > Discover Hardware**.

11.2 Adding an LMC-64 card (manual)

To add an LMC-64 card:

- 1) In **Hardware > Cards and Ports**, navigate to an available slot number (marked **Empty**). Do either of the following:
 - Double click the slot.
 - Right click the slot and select **Set Card Type**.



Figure 11-1 LMC-64 Card Selection

A drop-down menu is displayed, listing the available card types. Select **LMC-64**.

This action adds an LMC-64 card to be used for communication over IP between the LMC-64 card and a Dynam-EC PC client. Cards and Ports show a single port entry that can be configured for 16-64 meters.

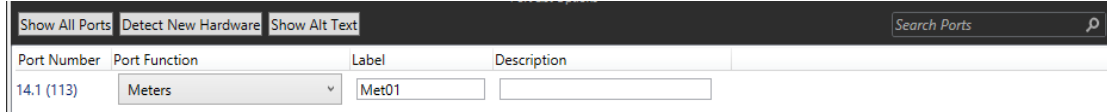

Figure 11-2 IP Ports

Note: When you add or remove a card in your configuration, the following message appears:

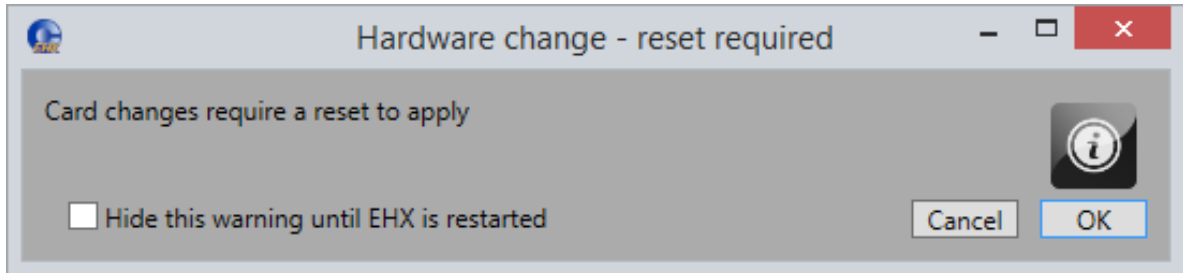

Figure 11-3 Hardware change

If your configuration contains linked matrices, the following message might appear when you apply changes to the matrix:

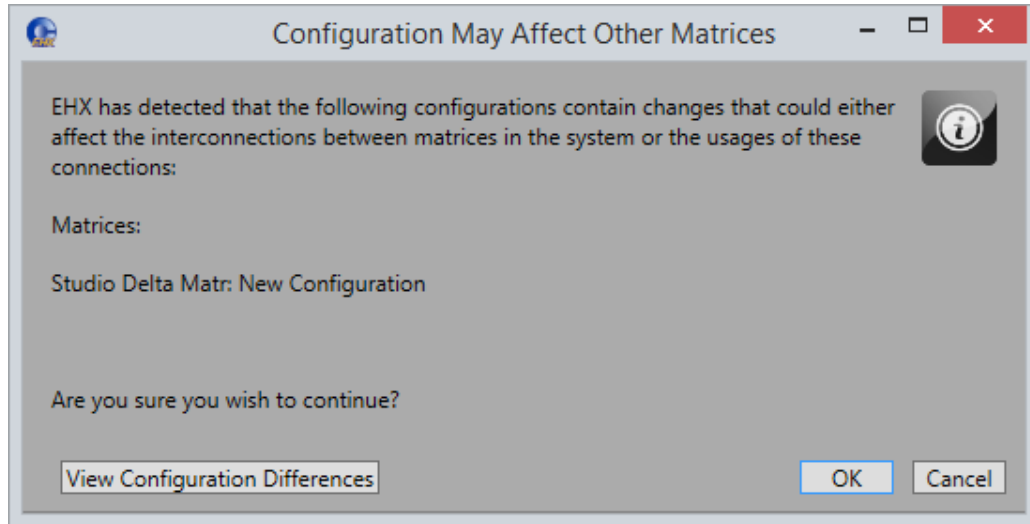

Figure 11-4 Configuration may affect other matrices

- 2) Click **View Configuration Differences** to see a list of possible interconnection issues.
- 3) Click **OK** to continue, or **Cancel**.
- 4) The LMC-64 Card Properties screen appears:

LMC-64 Card Properties	
TCP/UDP Port:	6001
DHCP Enabled:	<input type="checkbox"/>
IP Address:	169.254.0.101
Subnet mask:	255.255.0.0
Default gateway:	255.255.255.255
External IP Address:	169.254.0.101
External TCP/UDP Port:	6001
Close	

Figure 11-5 LMC-64 IP Parameters

Do one of the following:

- To accept the default settings, click **Close**.
- Change the edit fields as required, and then click **Close**.

Note: To view and edit the LMC-64 card properties at any time, double click on the LMC-64 Card Slot or right-click and select **Card Properties**.

After you have added a card, you can move it to another card slot as follows:

- 1) Right-click the card slot to be moved, and select **Move Card**.
- 2) Right-click the required empty card slot, and select **Paste Card (Move)**.

The card moves to its new position.

11.2.1 Setting the LMC-64 Card Properties

General

Default ports used by the Eclipse HX system are 6001 for IP Panel communications, 42001 for EHX communications and 1300 for the matrix event log. Ports 42001 and 1300 are used by the UDP/ protocol.

Ports 42001 and 1300 are not user adjustable.

Port 6001 is user adjustable.

Eclipse HX system administrators are advised to check with network administrators or IT that these default ports may be used without causing a conflict with any other application on the network.

It is recommended that each LMC-64 card uses a static IP address. It is recommended that these addresses are issued by IT or the Network Administrator to avoid conflicts

with any other system on the network and are not part of the DHCP dynamically assigned range.

TCP/UDP port

Sets the TCP/UDP port number to be used by the LMC-64 card when communicating over IP. This parameter should not normally be changed from the default value. Eclipse HX system administrators are advised to check with network administrators or IT that the default port may be used without causing a conflict with any other application on the network.

If the IP port number is changed ports 42001 and 1300 should not be used as these ports are already used by EHX. The Eclipse HX system administrator should check with the network administrator or IT to obtain a port number to use.

DHCP Enabled

The panel could obtain an address from a DHCP server, rather than use a static IP address. The use of a static IP address is the recommended method.

IP address

Static IP address of the LMC-64 card, assigned by IT or the Network Administrator. This is used by Dynam-EC clients to communicate with the LMC-64 card.

Important

It is important to ensure that the LMC-64 card IP address does not clash with any other IP address on the network (another device is using the same IP address). If there is an IP address clash the Dynam-EC clients may lose audio meter data. If the LMC-64 card IP address clashes it may also cause the LMC-64 card to crash.

Subnet mask

Subnet mask used by the LMC-64 card to define the address range the card can access. Typically, this is assigned by IT or the Network Administrator.

Default gateway

The address of the gateway (router) to be used to communicate with Dynam-EC clients over a wider IP network. This address is optional but if used must fall within the address range defined by the subnet mask.

External IP address

If the matrix is operating behind a firewall, then port address forwarding can be used to expose a LAN-connected device to the outside world. Typically, this is assigned by IT or the Network Administrator.

This IP address must be used by external Dynam-EC clients to communicate with the LMC-64 card. This address must be a unique address on the internet. It is not affected by the subnet mask.

External TCP/UDP port

IP port used when communicating directly with the LMC-64 card using the External IP address. The default port number is 6001 and this should not be changed unless the default port number on all external devices is also changed to the new port number.

11.3 Removing an LMC-64 card

To remove an LMC-64 card from the configuration:

- 1) In **Hardware > Cards and Ports**, navigate to the slot number of the LMC-064 card you want to delete.
- 2) Right click the slot and select **Set Card Type**.
- 3) A drop-down menu is displayed, listing the available card types. Select **Empty**.
- 4) A warning dialog is displayed. To confirm the deletion, click **Yes**.

When you remove a card, the warning message (Hardware change – reset required) above might appear.

11.4 Port Properties

To edit port properties, go to **Hardware > Cards and Ports**, and then select the required port. In the right-hand window, select the required property drop-down list.

11.4.1 Basic Options

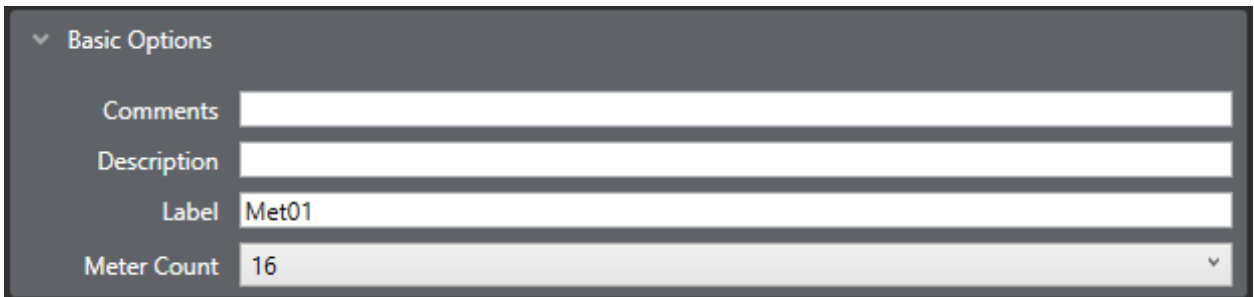

Figure 11-6 LMC-64 Basic Options

Comments

Enter an optional comment about the port and what it is used for.

Description

Enter an optional description of the port, up to 255 characters long.

Label

Enter a label for the port used to assign the port to a path. The label has 10 characters, or can be split into two parts, each of maximum five characters.

Meter Count

Select the number of meters provided by the LMC-64 card. Each meter allows Dynam-EC to meter on audio source or destination.

12 Adding and configuring an E-FIB card

The E-FIB fiber card is designed to provide fiber trunking between Eclipse HX-Omega, Eclipse HX-Median and Eclipse HX-Delta matrices. The fiber cards can also be configured to provide redundancy in communications link between Eclipse HX matrices. Each card provides two fiber rings.

12.1 Adding an E-FIB card (automatic discovery)

The E-FIB card is automatically discovered when:

- You select the **Discover Hardware** option after the Matrix is placed on the **System Layout** from the discovery pane.
- You right-click a matrix on the **System Layout** screen, and then select **Configuration > Select New Configuration > Discover Hardware**.

12.2 Adding an E-FIB card (manual)

To add an E-FIB card:

- 1) In **Hardware > Cards and Ports**, navigate to an available slot number (marked **Empty**). Do either of the following:
 - Double click the slot.
 - Right click the slot and select **Set Card Type**.
- 2) A drop-down menu is displayed, listing the available card types. Select either **E-FIB (Fiber)** or **E-FIB (Redundant)**.

Note: Only one E-FIB (Fiber) and one E-FIB (Redundant) card can be added. Clear-Com recommends that E-FIB cards are fitted to slots 6 and/or 7 of Eclipse HX-Median matrices, slots 14 and/or 15 of Eclipse HX-Omega matrices and slot 4 of Eclipse HX-Delta matrices.



Figure 12-1 E-FIB Fiber Card Selection

Note: When you add or remove a card in your configuration, the following message appears:

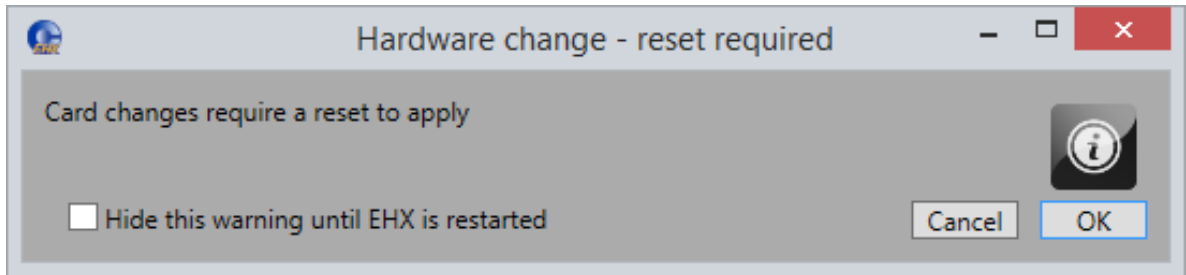

Figure 12-2 Hardware change

If your configuration contains linked matrices, the following message might appear when you apply changes to the matrix:

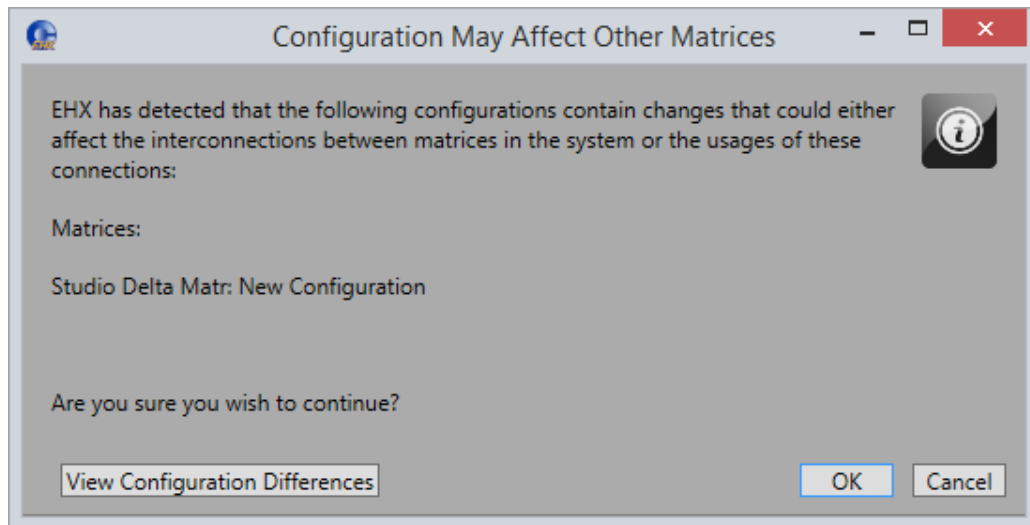

Figure 12-3 Configuration may affect other matrices

- 3) Click **View Configuration Differences** to see a list of possible interconnection issues.
- 4) Click **OK** to continue, or **Cancel**.

After you have added a card, you can move it to another card slot as follows:

- 1) Right-click the card slot to be moved, and select **Move Card**.
- 2) Right-click the required empty card slot, and select **Paste Card (Move)**.
The card moves to its new position.

12.3 Removing an E-FIB card

To remove an E-FIB card:

- 1) In **Hardware > Cards and Ports**, navigate to the slot number of the E-FIB card you want to delete. Do either of the following:
 - Double click the slot.
 - Right click the slot and select **Set Card Type**.
- 2) A drop-down menu is displayed, listing the available card types. Select **Empty**. A warning dialog is displayed. To confirm the deletion, click **Yes**.

12.4 Port Properties

To edit port properties, go to **Hardware > Cards and Ports**, and then select the required port. In the right-hand window, select the required property drop-down list.

12.4.1 Basic Options

The E-FIB card provides a single fiber port that can be configured to have Talk and Listen labels and a description.

Note: If E-FIB Fiber (Redundant) is selected, no ports are displayed because the card parameters cannot be configured.

Port Number	2.1 (17)
Comments	
Description	
Fiber Port Count	16
Label	Fib01
Remote Matrix Rx	0
Remote Matrix Tx	0

Figure 12-4 E-FIB Basic Options

Port Number

The port number is set to the next available port on the system. For example, if two MXV-A16 cards are installed before the fiber card the port number is set to 33 (16+16+1).

The port number cannot be changed in **Port Properties**.

Comments

Enter an optional comment about the port and what it is used for.

Description

Enter an optional description of the port, up to 255 characters long.

Fiber port count

The Fiber port count specifies the number of unidirectional fiber channels that are configured for the fiber card. The port count may be set to a maximum of 224 ports in multiples of 16. As a general guide, the port count (fiber channels) can be set to the maximum of 224 ports in networks with four or fewer matrices as this does not use all the timeslots (but see note below).

For networks with more than four matrices the port allocations must take account of the maximum number of simultaneous talks and listens across the network with a

maximum of 1024 timeslots being available. The matrix event log can be used to help tailor the port counts for the matrices. Alternatively, contact Clear-Com support for assistance in configuring the network.

Note: The port count should not be set to an excessive number (significantly more than the number of panels available for connection via the fiber card) as this may reduce system performance. Different matrices can have different fiber port counts.

Label

Enter a label for the port used to assign the port to a path. The label has 10 characters, or can be split into two parts, each of maximum five characters.

Remote Matrix Rx

The system number of the frame that the remote matrix receives data from in the primary fiber loop.

Remote Matrix Tx

The system number of the frame that the remote matrix transmits data to in the primary fiber loop.

13 Adding and configuring an E-MADI64 card

The E-MADI64 is a Multichannel Audio Digital Interface card (MADI), providing up to 64 duplex channels of AES3 digital audio over a coaxial cable or fiber pair between compatible devices.

13.1 Adding an E-MADI64 card (automatic discovery)

The E-MADI64 card is automatically discovered when:

- You select the **Discover Hardware** option after the Matrix is placed on the **System Layout** from the discovery pane.
- You right-click a matrix on the **System Layout** screen, and then select **Configuration > Select New Configuration > Discover Hardware**.

13.2 Adding an E-MADI64 card (manual)

To add an E-MADI64 card:

- 1) In **Hardware > Cards and Ports**, navigate to an available slot number (marked **Empty**). Do either of the following:
 - Double click the slot.
 - Right click the slot and select **Set Card Type**.
- 2) A drop-down menu is displayed, listing the available card types. Select an E-MADI64 card. The options are:
 - E-MADI 32/32
 - E-MADI 56/56
 - E-MADI 64/64
 - E-MADI 64/32
 - E-MADI 64/16

Note: If you use an RME fiber transceiver, you must have at least 6dB of attenuation.

Note: When you add or remove a card in your configuration, the following message appears:

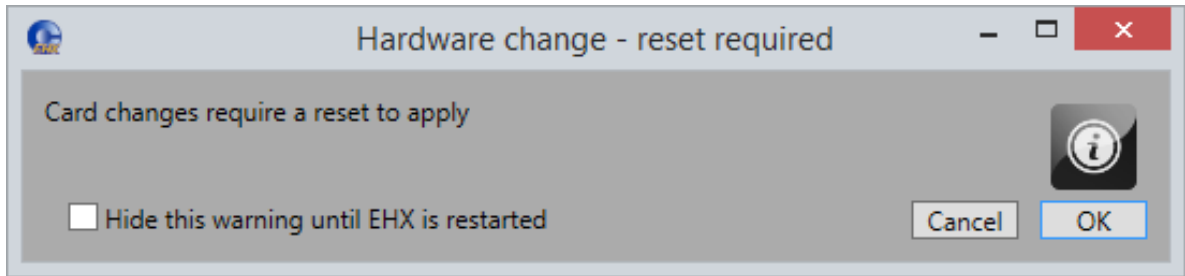

Figure 13-1 Hardware change

If your configuration contains linked matrices, the following message might appear when you apply changes to the matrix:

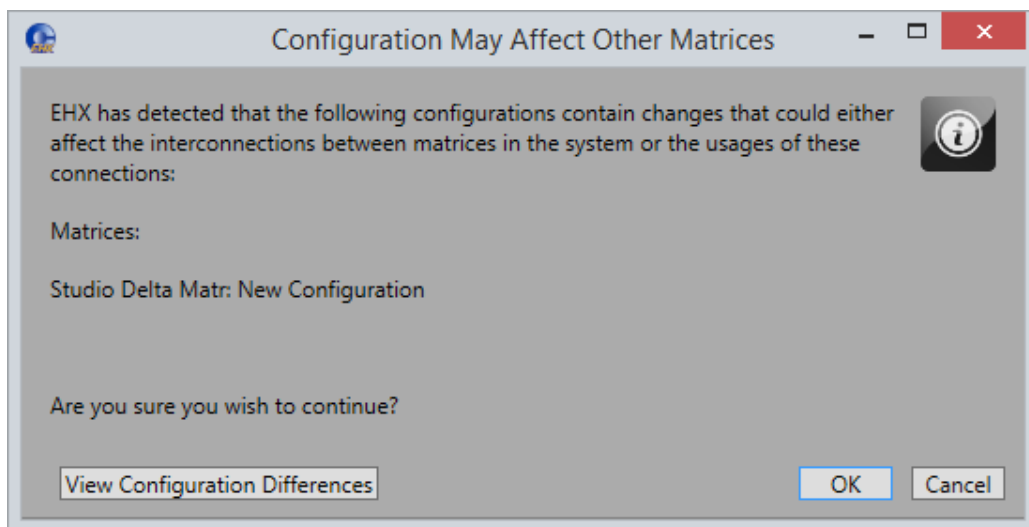

Figure 13-2 Configuration may affect other matrices

- 3) Click **View Configuration Differences** to see a list of possible interconnection issues.
- 4) Click **OK** to continue, or **Cancel**.
- 5) The E-MADI64 Card Properties screen appears:

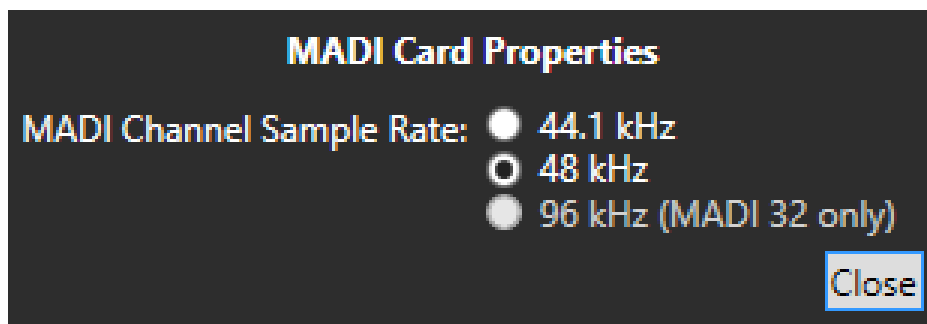

Figure 13-3 E-MADI64 Card Properties

Do one of the following:

- To accept the default settings, click **Close**.
- Change the edit fields as required, and then click **Close**.

Note: To view and edit the EMADI-64 card properties at any time, double click on the EMADI-64 Card Slot or right-click and select **Card Properties**.

After you have added a card, you can move it to another card slot as follows:

- 1) Right-click the card slot to be moved, and select **Move Card**.
- 2) Right-click the required empty card slot, and select **Paste Card (Move)**.
The card moves to its new position.

13.3 Removing an E-MADI64 card

To remove an E-MADI64 card:

- 1) In **Hardware > Cards and Ports**, navigate to the slot number of the EMADI-64 card you want to delete. Do either of the following:
 - Double click the slot.
 - Right click the slot and select **Set Card Type**.
- 2) A drop-down menu is displayed, listing the available card types. Select **Empty**. A warning dialog is displayed.
To confirm the deletion, click **Yes**.

13.4 Setting E-MADI64 Card Properties

Card Properties permits sample rate selection when synching to video signals. The E-MADI64 card must be configured before it can be used when not using the Word Clock Source Sync.

Card Properties always defaults to the E-MADI64 standard for the number of channels.

E-MADI channel mode	Sample rate	Configurable ports
32	96K	32
56	44.1K or 48K	56
64	44.1K or 48K	64, 32 or 16

Table 13-1 E-MADI Channel modes

13.5 Setting the port function

To set the port function:

- 1) Click the Port Function field. A drop-down menu is displayed.
- 2) From the drop-down menu, select the desired device (user panels and interfaces that may be connected to the port).

The available device types are listed below:

- Empty
- Direct
- Panel Aux
- Trunk
- V 1RU Lever
- V 1RU Push
- V 1RU Rotary
- V 2RU Lever (24 key)
- V 2RU Lever (32 key)
- V 2RU Push
- V 2RU Rotary
- V Desktop Lever
- V Desktop Push
- V Desktop Rotary

Note: If you right-click on a port and select **Find Usages**, a list of other EHX entities which refer to the port is given.

13.6 Port Properties

To edit port properties, go to **Hardware > Cards and Ports**, and then select the required port. In the right-hand window, select the required property drop-down list.

The following are available.

Menu item	Section
Basic Options	8.5.1 Basic Options
Panel Options	8.5.2 Panel options
Assignment Panel Options	8.5.3 Assignment panel (AP) options
Menu Options	8.5.4 Menu options
Voice Operated Switch Options	8.5.5 Voice operated switch (VOX) options
Global Options	8.5.6 Global options
Gain Options	8.5.8 Gain Options
Audible Alert Options	8.5.9 Audible alert options
Tally Options	8.5.10 Tally options
Fast Key Assign Options	8.5.11 Fast key assign options
Logic Input Options	8.5.12 Logic input options
Attached Control Options	8.5.13 Attached control options

Table 13-2 Port properties

Note: The available port properties options depend on the selected Port Function.

13.6.1 E-MADI64 channel labeling

The 4-character channel ID for each MADI input channel can be taken from the provided embedded data bits. The channel ID for each MADI output channel can be enabled in EHX.

You can do any of the following:

- Use the **4-character**, 3rd party ID, provided from the input channel.
- Use the Dynam-EC Alias.
- Disable the ID and use the **EHX port name** for display on EHX Panels.

This means that supported user panels can automatically show:

- The MADI channel ID.
- The Alias as supplied from Dynam-EC.
- The Talk / Listen label as defined in EHX.

13.7 Upgrading the E-MADI64 card firmware

You can upgrade the following E-MADI64 code with EHX:

- H8 application code (*.fwc format file).

- DSP code (*.fwc format file).
- FPGA code (*.fwc format file).

The boot code file (*.mot) is upgraded using the Renesas Flash Development Toolkit 3.4 Basic (FDT), **not** EHX. The FPGA code can also be upgraded using Xilinx iMPACT programming software.

Note: For detailed upgrade procedures and information, including upgrades that you **cannot** perform in EHX, see the **Eclipse HX Upgrade Guide**.

To upgrade E-MADI64 H8, DSP or FPGA code (for all the E-MADI64 cards) using EHX:

- 1) Ensure that you have the following equipment:

Equipment	Description / Notes
PC with an Ethernet or serial port	-
EHX software	EHX must be installed and configured
Ethernet or serial connection	For the matrix to PC connection
H8 application, DSP and FPGA code files	The appropriate application code, DSP code and FPGA code files (*.fwc format) are available from the Eclipse HX DVDs: Software DVD > Eclipse HX-Omega-Median-Delta > E-MADI Application Software DVD > Eclipse HX-Omega-Median-Delta > E-MADI DSP Hardware DVD > Eclipse HX-Omega-Median-Delta > E-MADI FPGA.

Table 13-3 Upgrading e-MADI64 code

- 2) Start EHX on the PC.
- 3) Connect the matrix to the PC using either an Ethernet or serial port.
- 4) In EHX, open the configuration. Select **System > Layout**.
- 5) Right click the matrix and then select **Firmware> Update Firmware**.
- 6) The **Update Firmware** wizard dialog is displayed. Click **Next**. In the **Select Hardware Type** screen, ensure that the **Card** radio button is selected:

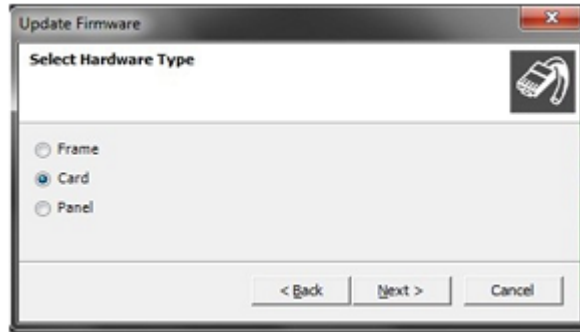

Figure 13-4 Select Hardware Type dialog

- 7) Click **Next** and then browse to the E-MADI64 code file (application, DSP or FPGA code files (*.fwc)).

The folder contains the *.fwc file and a *Read Me* file (*.txt) with version information. Select the *.fwc file and click **OK / Open**.

Note: See **Step 1** for the location of the *.fwc files on the Eclipse HX DVDs.

- 8) Click **Next** and confirm that the details displayed are correct.
- 9) Click **Next** and confirm that the download commences.
- 10) When the download has completed, click **Finish** to close the update firmware wizard.
- 11) Ensure that the E-MADI64 cards reset once the download is complete.

Code	Approximate reset time
H8 application	1 minute
DSP	3 minutes
FPGA	18 minutes

Table 13-4 E-MADI64 card reset times

When the download has completed, click **Finish** to close the update firmware wizard.

14 Adding and configuring an E-Dante64 card

The E-Dante64 interface card is a Clear-Com matrix interface card that works with Dante network protocols and software. You can transport many channels of high quality audio using a Clear-Com matrix connected to multiple Dante enabled devices using standard Ethernet network structure (up to 64 channels per E-Dante64 card).

For information about the Audinate Dante Controller, refer to the Audinate Dante Controller User Guide and additional training materials on the Audinate website.

For information about the status LEDs, buttons and connectors that are present on the card, refer to the relevant Eclipse Matrix User Guide. You will also find example user cases for the E-Dante card in the Clear-Com matrix user guides.

14.1 Adding an E-Dante64 card (automatic discovery)

The E-MADI64 card is automatically discovered when:

- You select the **Discover Hardware** option after the Matrix is placed on the **System Layout** from the discovery pane.
- You right-click a matrix on the **System Layout** screen, and then select **Configuration > Select New Configuration > Discover Hardware**.

14.2 Adding an E-Dante64 card (manual)

To add an E-Dante64 card:

- 1) In **Hardware > Cards and Ports**, navigate to an available slot number (marked **Empty**). Do either of the following:
 - Double click the slot.
 - Right click the slot and select **Set Card Type**.
- 2) A drop-down menu is displayed, listing the available card types. Select an E-Dante64 card. The options are:
 - E-Dante 16
 - E-Dante 32
 - E-Dante 64

Choose according to the number of channels you need.

Note: You can install a maximum of seven E-Dante64 cards on a matrix. Total ports allocated on these cards must not exceed 496. If you use a sample rate of 96k, this automatically limits the card to 32 channels, so if using this sample rate you should allocate only 32 channels to the card in EHX.

Note: When you add or remove a card in your configuration, the following message appears:

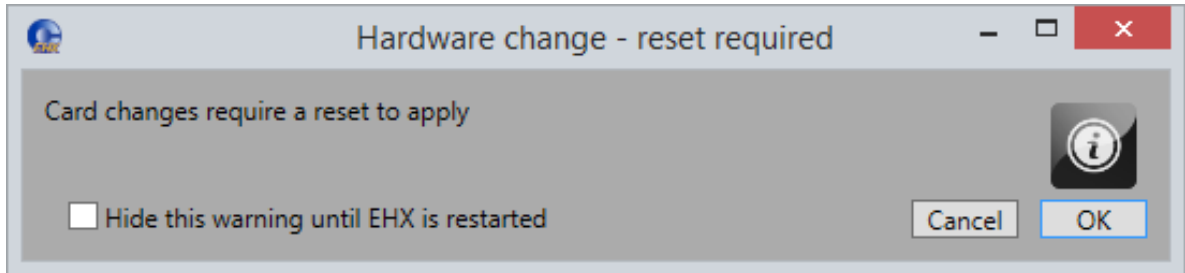

Figure 14-1 Hardware change

If your configuration contains linked matrices, the following message might appear when you apply changes to the matrix:

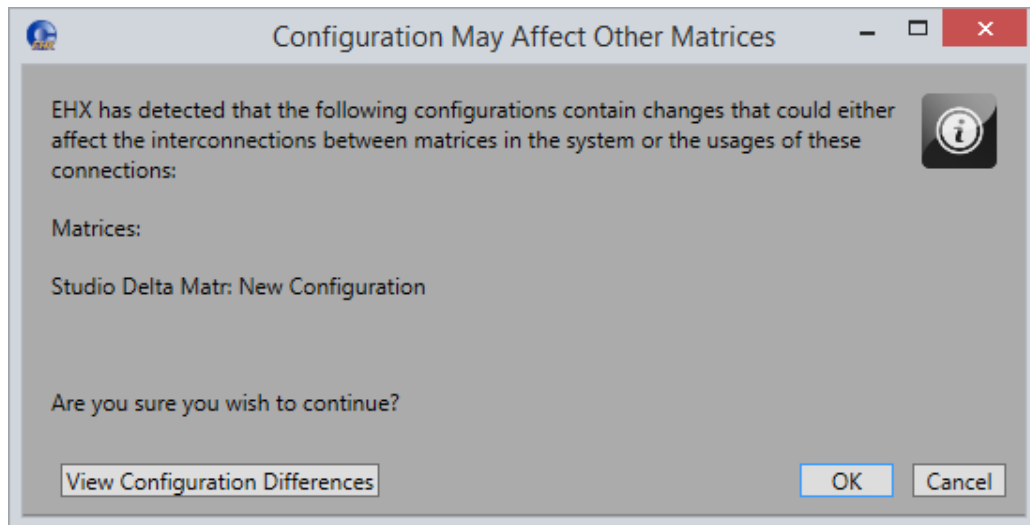

Figure 14-2 Configuration may affect other matrices

- 3) Click **View Configuration Differences** to see a list of possible interconnection issues.
- 4) Click **OK** to continue, or **Cancel**.
- 5) The E-Dante64 Card Properties screen appears:

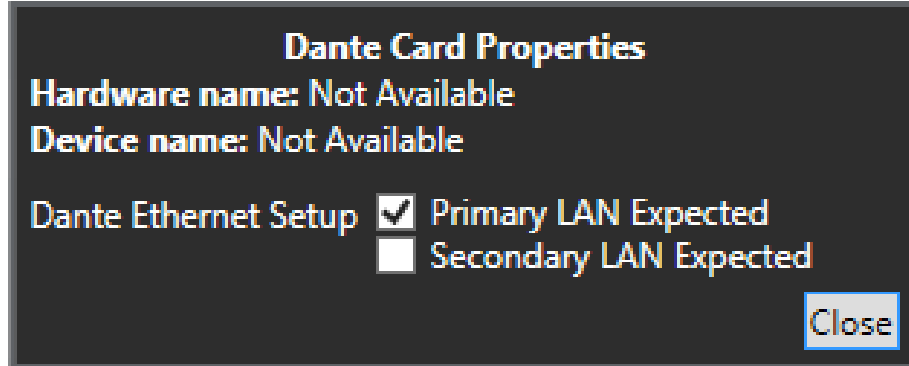

Figure 14-3 E-MADI64 Card Properties

Do one of the following:

- To accept the default settings, click **Close**.
- Change the edit fields as required, and then click **Close**.

Note: To view and edit the E-Dante64 card properties at any time, double click on the E-Dante64 Card Slot or right-click and select **Card Properties**.

After you have added a card, you can move it to another card slot as follows:

- 1) Right-click the card slot to be moved, and select **Move Card**.
- 2) Right-click the required empty card slot, and select **Paste Card (Move)**.
The card moves to its new position.

14.3 Setting the E-Dante64 Card Properties

Set primary and secondary network expectations. If you don't do this, you may see the red error condition LED flash on the front of the Dante card. See section **14.8.3 Redundancy options** for a full explanation of this feature. The default setting is **Primary LAN Expected** only.

14.4 Setting the Port Function

To set the port function:

- 1) Click the Port Function field. A drop-down menu is displayed.
- 2) From the drop-down menu, select **Direct** or **Trunk**. The most common port function is **Direct**. Use **Trunk** to make an intelligent link to another Clear-Com matrix.

14.5 Dante labels

There is no connection between labels in EHX and labels in the Dante network. However, it is advisable to use a similar label for connecting channels and devices in each context to avoid confusion.

Note: You can choose to see Dante labels in Eclipse using Auto Aliasing. See section **Set Auto Alias Updates to show Dante channel names**.

14.6 Hardware name detection

If an E-DANTE card hardware name does not match the expected name for a given slot in the matrix, the following error message appears:

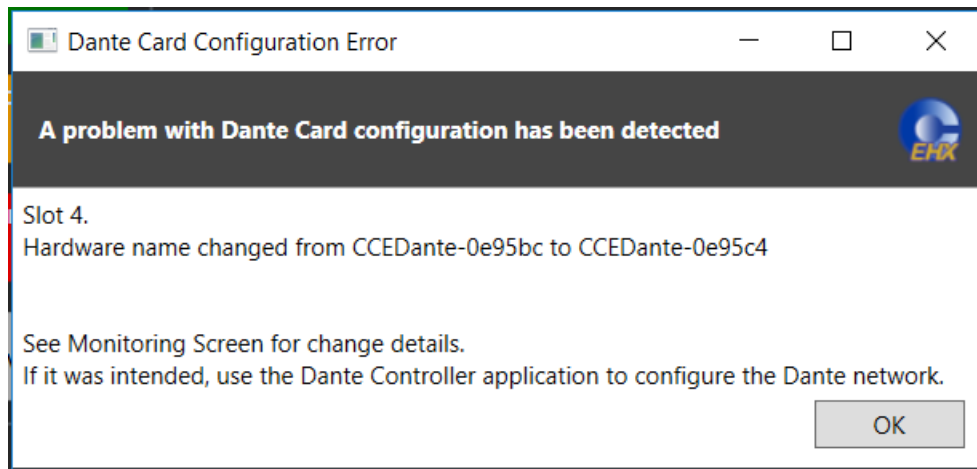

Figure 14-4 Dante card configuration error

Click **OK** to update the EHX map with the new hardware name. When you apply the map to the matrix, the error clears. Otherwise, insert the E-DANTE card with the expected hardware name into the matrix.

Note: This error message also appears in the Monitoring screen, see section **27.5 E-DANTE-HX interface card**.

14.7 Port Properties

To edit port properties, go to **Hardware > Cards and Ports**, and then select the required port. In the right-hand window, select the required property drop-down list. The following are available.

Menu item	Section
Basic Options	8.5.1 Basic Options
Voice Operated Switch Options	8.5.5 Voice operated switch (VOX) options
Global Options	8.5.6 Global options
Fast Key Assign Options	8.5.11 Fast key assign options
Gain Options	8.5.8 Gain Options
Tally Options	8.5.10 Tally options
Attached Control Options	8.5.13 Attached control options

Table 14-1 Port properties

Note: The available port properties options depend on the selected Port Function.

14.8 Configuring the Dante interface

- 1) Open the Dante Controller software.
The Dante Controller will see all Dante enabled devices on its network and you should see the Clear-Com Dante card in the **Routing** page of the Controller (assuming the network is connected and working).
- 2) **Label** channels and device as required. Double click on the device in the Dante Routing page to access device configuration options to change names and labels.

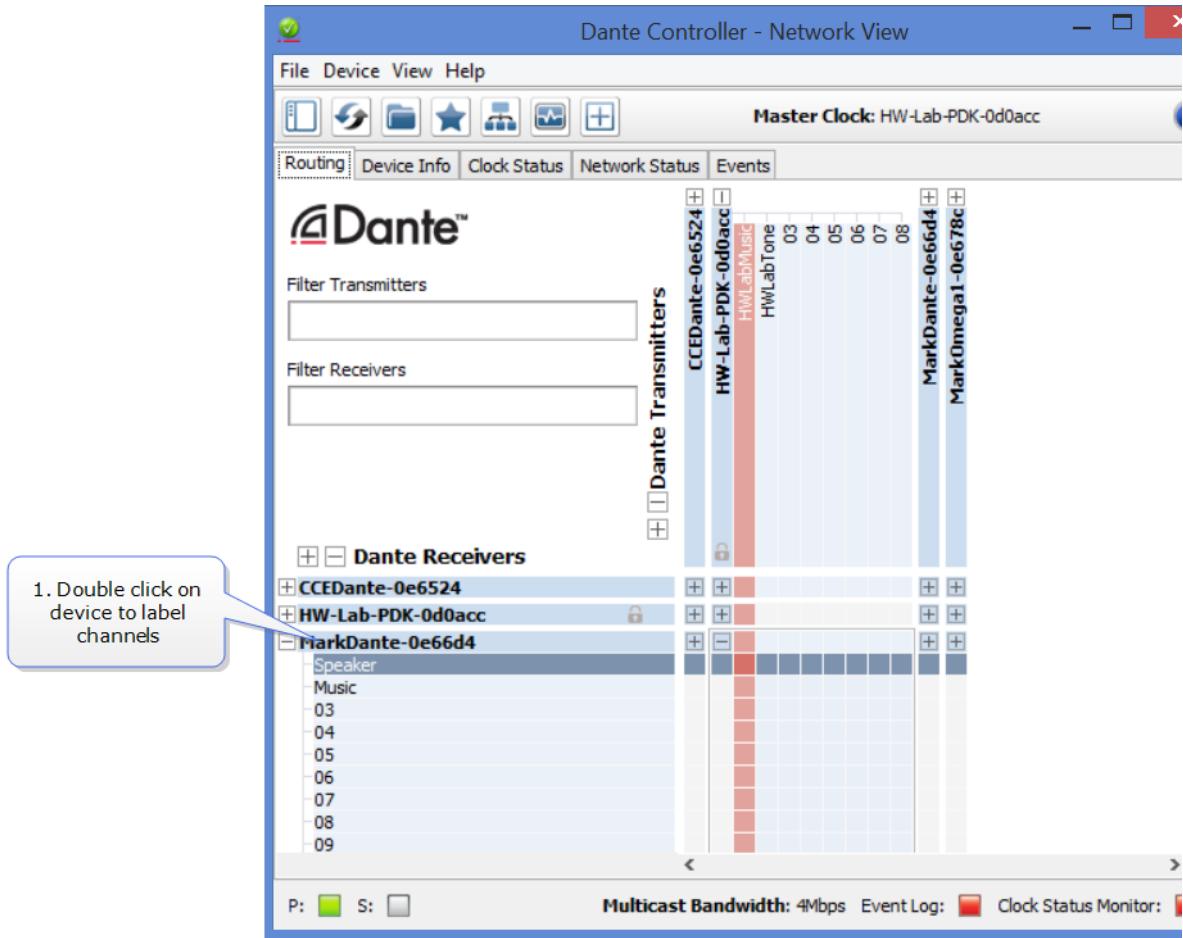
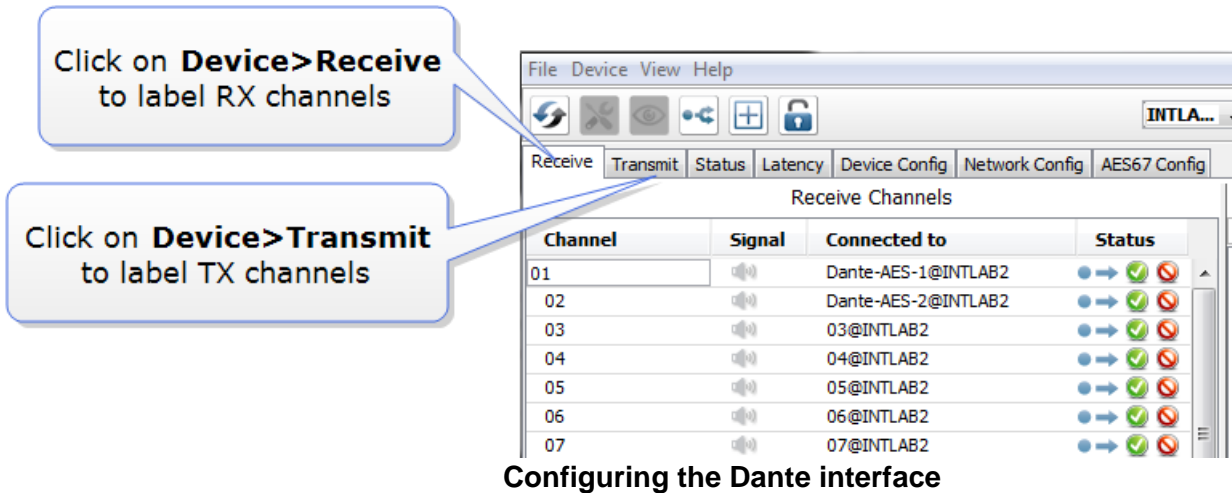

Figure 14-5



- 3) Make connections (subscriptions) between devices by locating required crosspoints and clicking to connect.

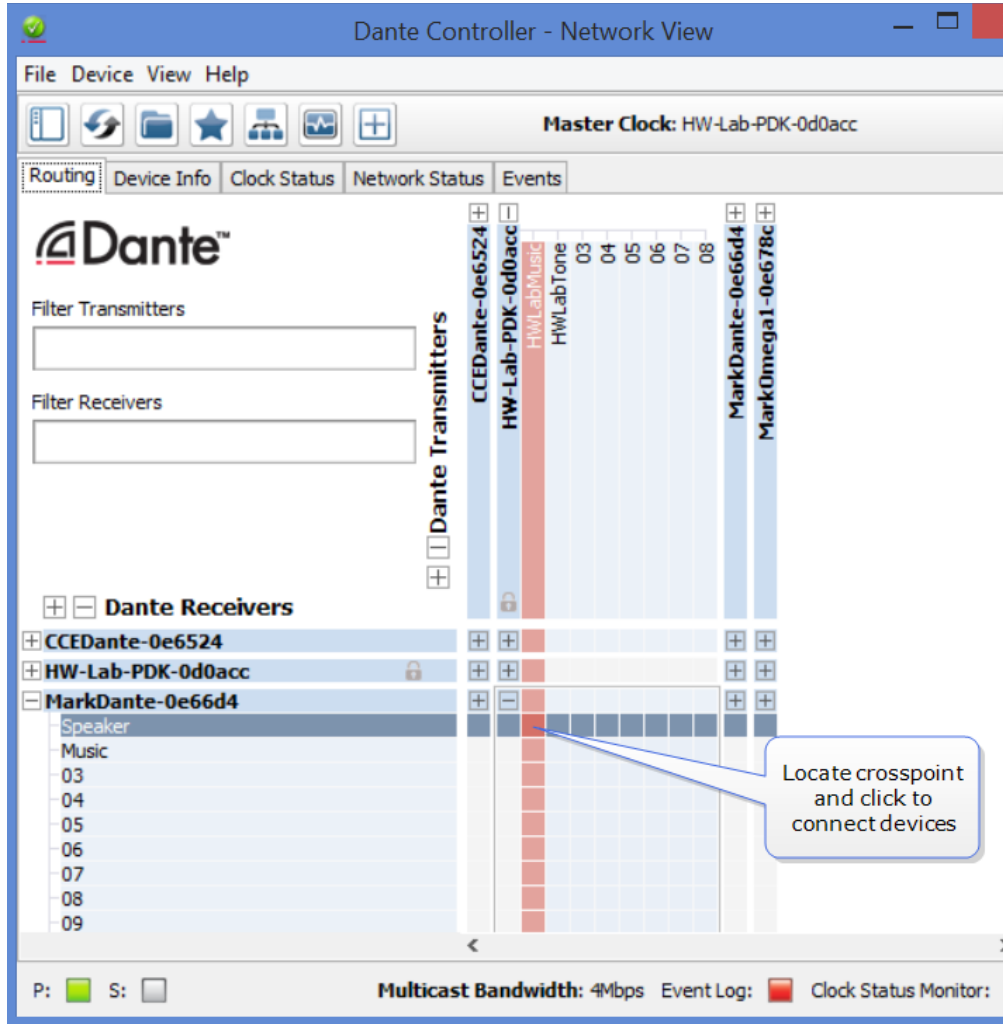

Figure 14-6 Network view

Note: The Dante interface will provide error messages if there is a settings mismatch.

14.8.1 Network configuration

IP addressing is handled by the Dante software:

Automatic network configuration

A Dante-enabled device connected to a network will automatically setup its own network configuration, including its IP address.

If the network has a DHCP server, which may be the case for installed networks, it will receive its IP configuration using the standard DHCP protocol.

On a network without a DHCP server, which may be the case for temporary or smaller networks, the Dante-enabled device will automatically assign itself an address using link local protocols, in the same way PCs and printers often do.

See *Audinate Dante Controller User Guide*, 2016 Audinate Pty Ltd.

Note: DHCP is the preferred method of IP allocation when using Dante.

Note: Clear-Com recommends that the Eclipse Matrix (CPU-LAN) IP address uses a fixed/static IP address.

14.8.2 Label exchange between Dante and Eclipse

Within the Dante network, Dante enabled devices and associated audio channels are identified by names (labels). This contributes to an interface that is easy to read and use. When interfacing an Eclipse system with Dante, you can show the Dante channel names on ports using **Auto Alias Updates**. This makes redirecting or reconfiguring any networked audio set up much faster and easier.

Note: The E-DANTE card uses its own NIC Ethernet port. The IP address of the Ethernet port is set using the Dante controller software.

Choose from three different **Auto Alias Update** options:

Auto Alias Update option	Effect on labels seen on panels and in Dynam-EC
Disabled	Use EHX labels only.
RX Channel Label	Receive channel labels from Dante are used as the alias for that port.
Source Tx Channel Label	Source transmit channel labels from Dante are used as the alias for that port. If no current subscription is made, the receive channel label is shown.

Table 14-2 Auto alias update options

Auto Alias Update option set to **RX Channel Label**:

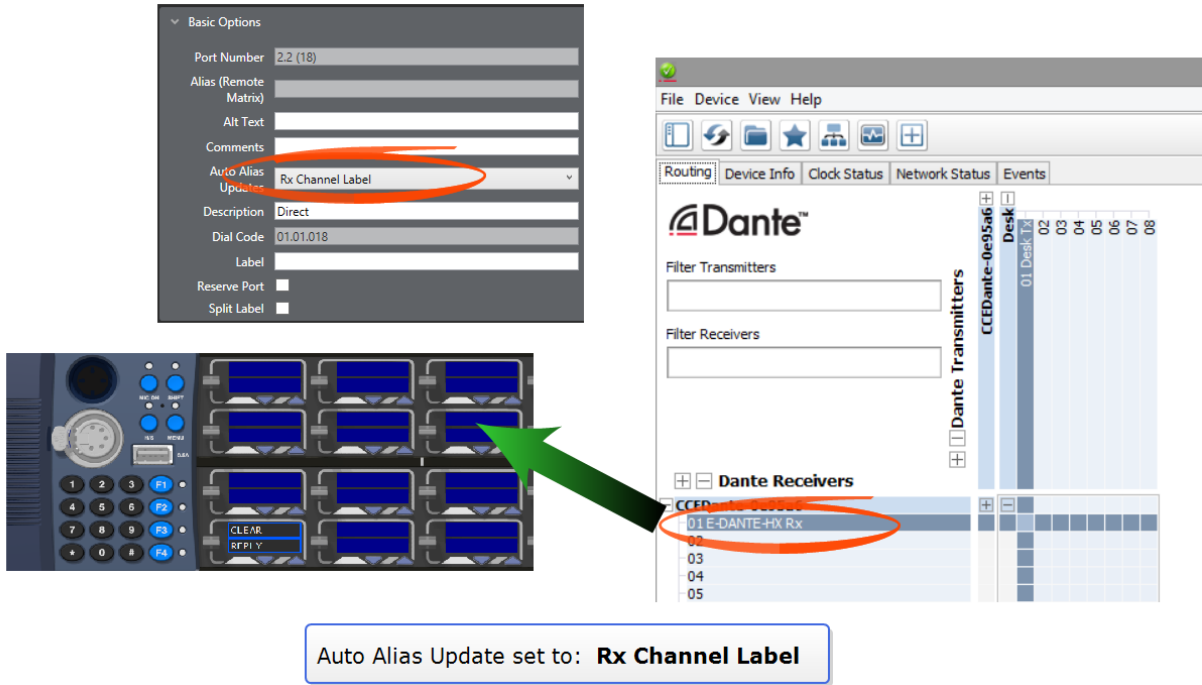
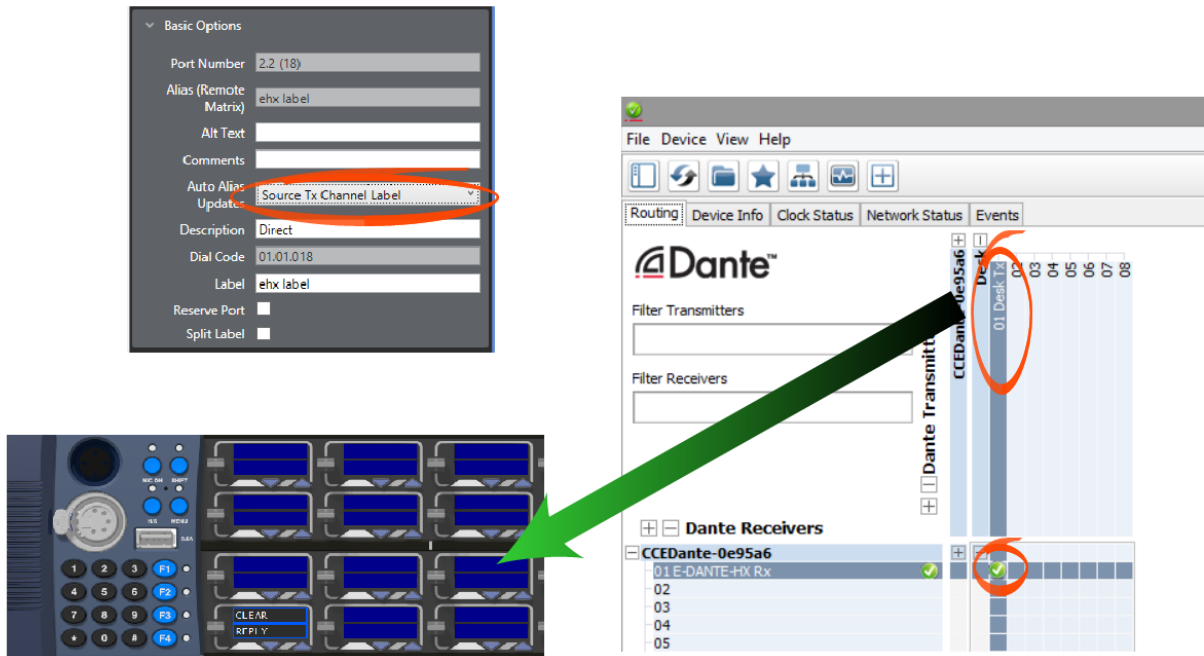

Figure 14-7 Auto Alias Update option set to RX Channel Label

Auto Alias Update option set to **Source Tx Channel Label** with audio subscription:



Auto Alias Update set to: **Source Tx Channel Label**
WITH subscription made on crosspoint.

Figure 14-8 Auto Alias Update option set to Source Tx Channel Label with audio subscription

Auto Alias Update set to **Source Tx Channel Label**, NO audio subscription:

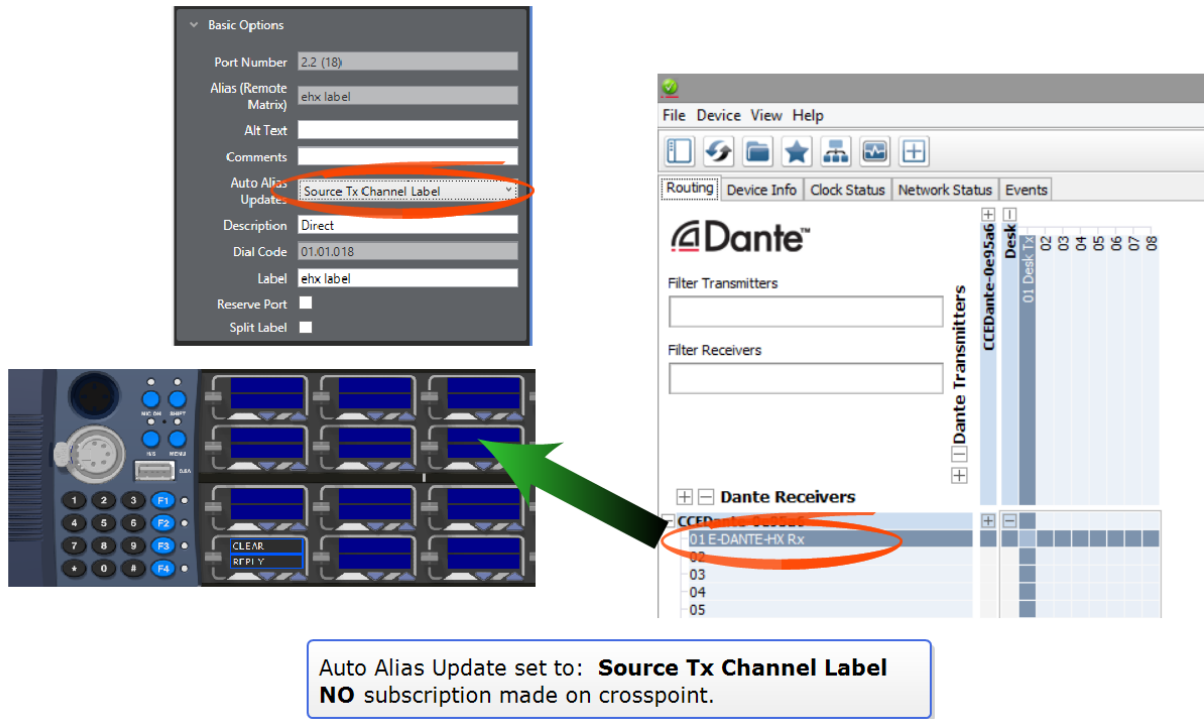

Figure 14-9 Auto Alias Update set to Source Tx Channel Label, NO audio subscription

Set Auto Alias Updates to show Dante channel names

- 1) In the EHX software, navigate to **Cards and Ports > E-DANTE64 > Port > Port Properties > Basic Options > Auto Alias Updates**.
- 2) Click the small arrow on the right to access drop-down menu and select required option.
- 3) Click **Apply Map to Matrix**.

Note: Auto Alias Updates only works on ports configured as Directs, Trunk labels will not show Dante labels.

Note: Labels in EHX contain a maximum of 10 characters. Dante labels can use up to 30 characters, so only the first 10 characters of the Dante label will be shown in Eclipse.

Note: If a port has a split label then only the listen and forced listen labels are overwritten by the alias.

14.8.3 Redundancy options

Configure Primary and Secondary networks

Dante enabled devices can run audio on two networks simultaneously. This means that if one network fails for any reason (for example a cable is pulled out) the other network will take over with no interruptions to the audio.

To set up the redundant networks, first cable and test the Primary network and then connect alternative cables to the Secondary network connectors.

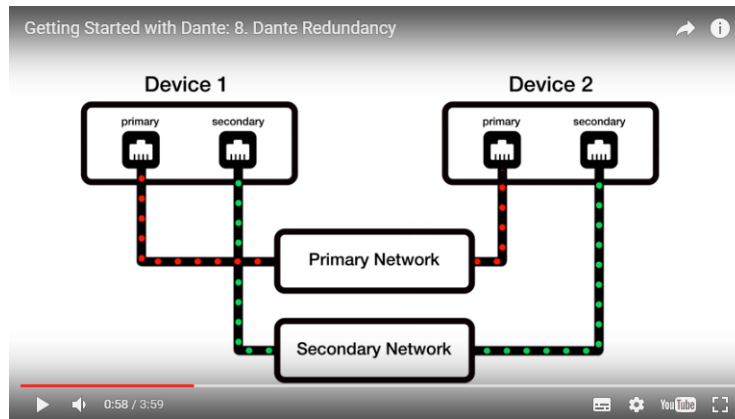

Figure 14-10 Redundancy options

Ref: <https://www.audinate.com/resources/videos/g8-dante-redundancy-getting-started-dante-video-series> last accessed 12 October 2016

Settings are automatically copied from the Primary network to the Secondary network, so no further configuration is necessary. Check that networks are working as expected in the **Network Status** page of the Dante Controller.

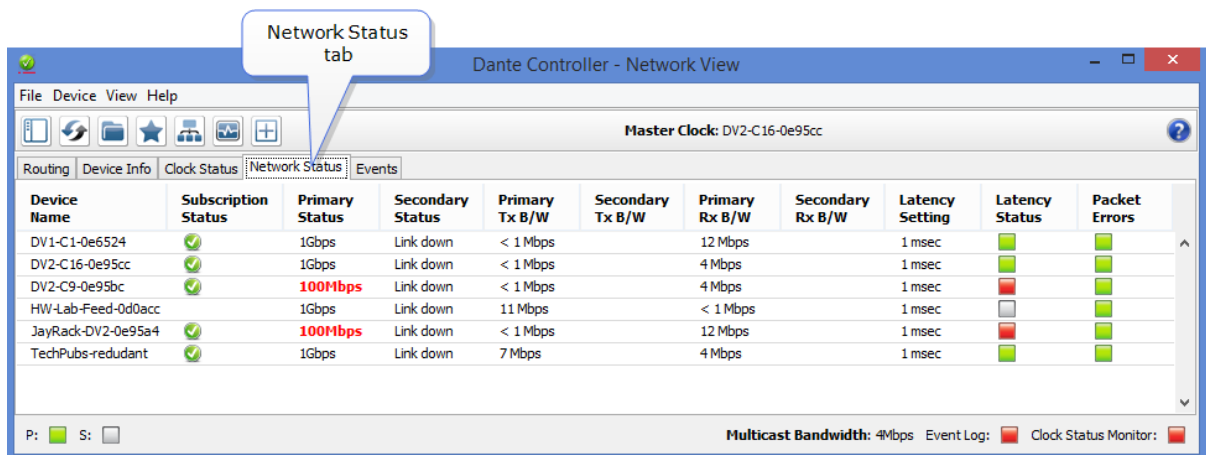

Figure 14-11 Network view

Set Primary and Secondary network expectations in EHX

The Eclipse-HX system and the E-DANTE64 card have diagnostic and error reporting facilities. For these to work properly, it is necessary to specify whether you plan to use the Primary network only or both networks together. This prevents the system from reporting false connection flags.

You must specify which networks you expect to use when you configure the E-DANTE64 card in the EHX software.

The default setting is **Primary LAN Expected** only. Some Dante devices only have a primary network, so always use this network first.

- 1) In the EHX configuration software, navigate to **Cards and Ports**. Right click on the E-Dante64 card and select **Card Properties**.
- 2) Use the check box to specify which network or networks you expect to use and want to receive monitoring information on.

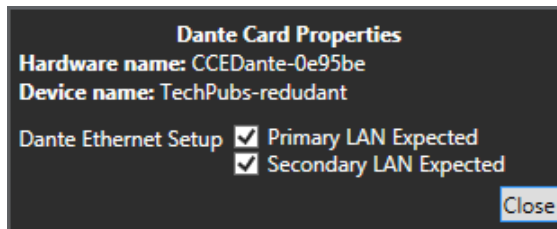

Figure 14-12 Card properties

- 3) If you check a LAN connection in this box, and the network is not physically connected, the red error LED on the front of the E-DANTE64 card will light.

In this dialog box you can also see the hardware name and device name for the card. The hardware name cannot be changed and uniquely identifies that card. The device name can be changed in the Dante Controller.

E-DANTE64 replacement card options

In addition to a backup network, you might want a replacement or backup of an E-DANTE64-HX interface card with your set-up map. In this case, you should save a copy of your configuration using the Dante **Save Preset** function, ready to apply to a replacement card if needed.

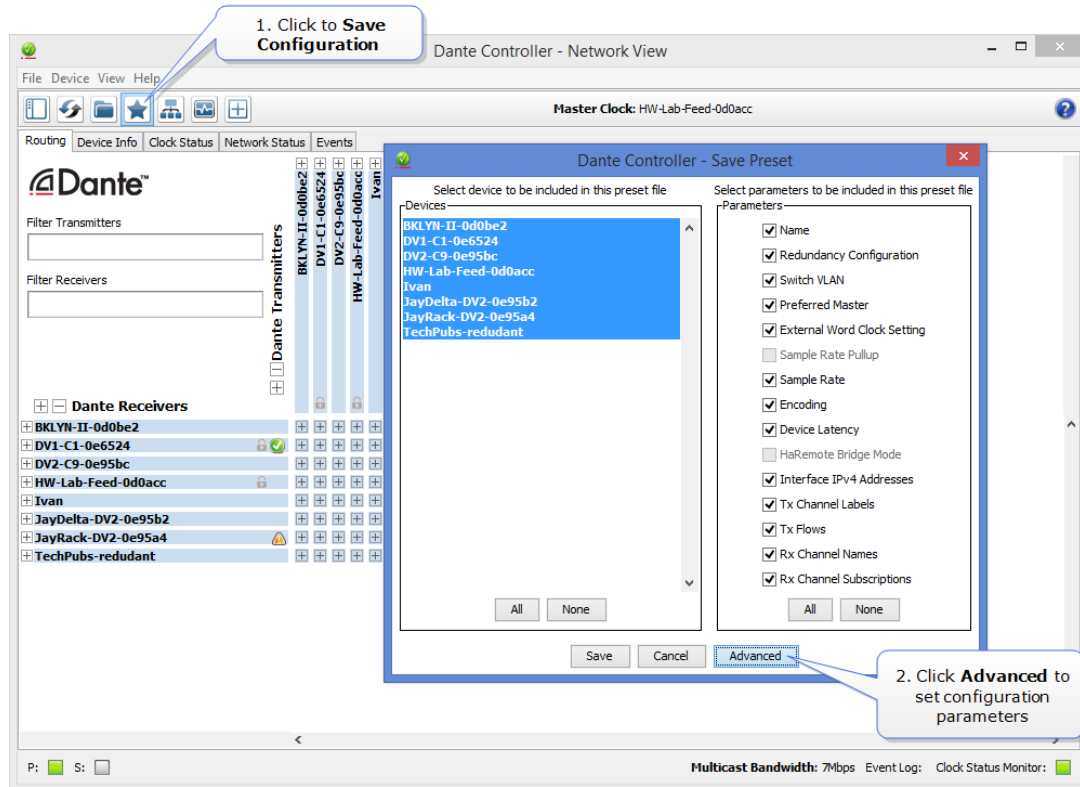

Figure 14-13 Replacement card options

Procedure for installing a replacement or backup card

When you remove an E-DANTE64-HX interface card from the Clear-Com matrix rack, any channel subscriptions (connections) that have been made in the Dante Controller are also removed as they are stored on the card. You need to re-apply these subscriptions in the Dante Controller using the **Load Preset** function for the backup card.

- 1) Make sure you have saved your configuration using **Save Preset** in the Dante controller.
- 2) Remove the front E-DANTE64 card from the matrix rack by gently opening the side ejector tabs and pulling the card out of its slot.
- 3) Carefully insert the new card and push it home, closing the side ejector tabs to secure it in the matrix.

Caution: The new card may have pre-existing configuration on it. Use the Dante controller to make sure that the configuration is as you want it.

- 4) Open the Dante Controller and apply the required preset configuration (**File > Load Preset**).

At this point, you can either use the card immediately, or you can check that audio is flowing as required and keep the replacement card aside for use when needed.

Note: Changing the E-DANTE64 rear card requires a power down of the matrix. The front card can be replaced without power-down (hot plugged).

14.8.4 AES67 flow configuration

The Dante card can also be configured to interface with third-party AES67 equipment.

The Dante card can support any mix of Dante and AES67 flows, up to the maximum supported on the device. Configuration persists over reboots.

The receive latency for AES67 Rx flows is set to 2 ms. This latency setting is not affected by changing the latency setting in the Dante controller.

Note: Third party AES67 devices will need to be configured separately.

14.8.5 AES67 Guidelines

When connecting devices to route AES67 audio streams with your E-DANTE 64 card, the following general principles should be noted:

- AES67 uses IEEE1588-2008 Precision Time Protocol (PTP) to ensure synchronization between devices. All networked devices, including your network switch must support this standard.
- You need to disable any Energy Efficient Ethernet (EEE) switches, as these will disrupt the synchronization of audio streams.
- All networked devices need to support multicast routing. The Dante system defaults to multicast when routing AES67 streams.
- Multicast routing uses the Class D range of IP addresses (224.x.x.x – 239.x.x.x). For AES67 streams, chose an IP range that does not conflict with other network traffic. Consult your network administrator if necessary.
- It is recommended that Internet Group Management Protocol (IGMP) snooping is enabled on your network switch. This will avoid the possibility of flooding your network.

- Dante uses Session Announcement Protocol (SAP) to discover devices on a network. If any of your devices do not support SAP, the Dante Controller will not be able to see them. In this case, you need to use a SAP conversion tool, such as the free Ravenna-2-SAP converter available from the Ravenna website (<https://www.ravenna-network.com/>).

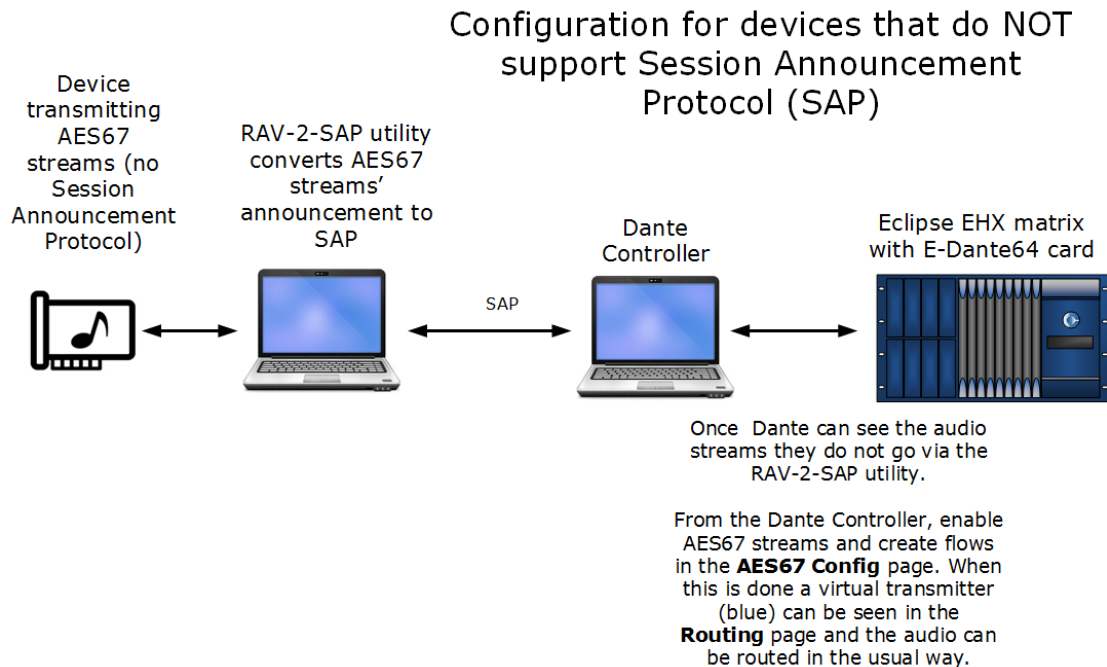

Figure 14-14 Configuration for AES67 devices that do not support SAP

14.8.6 How to enable AES67 flows in the Dante controller

- 1) Open the Dante Controller. Double click the required device in the **Network View**. This opens **Device View** for that device.
- 2) Select the **AES67 Config** tab and enable AES67 mode. Reboot the device. When the device has rebooted, you will see that a multicast IP address has been allocated to the device.

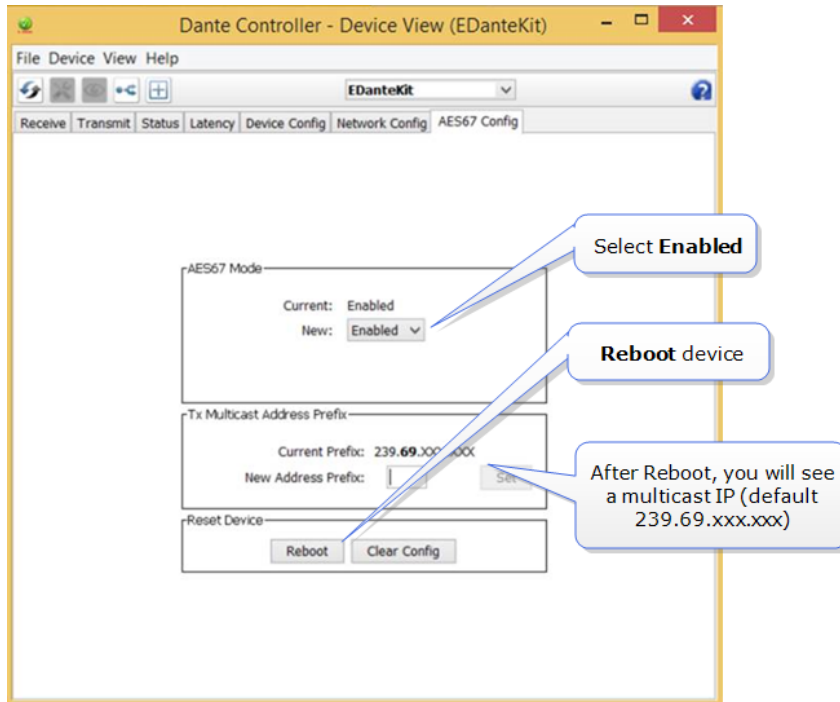
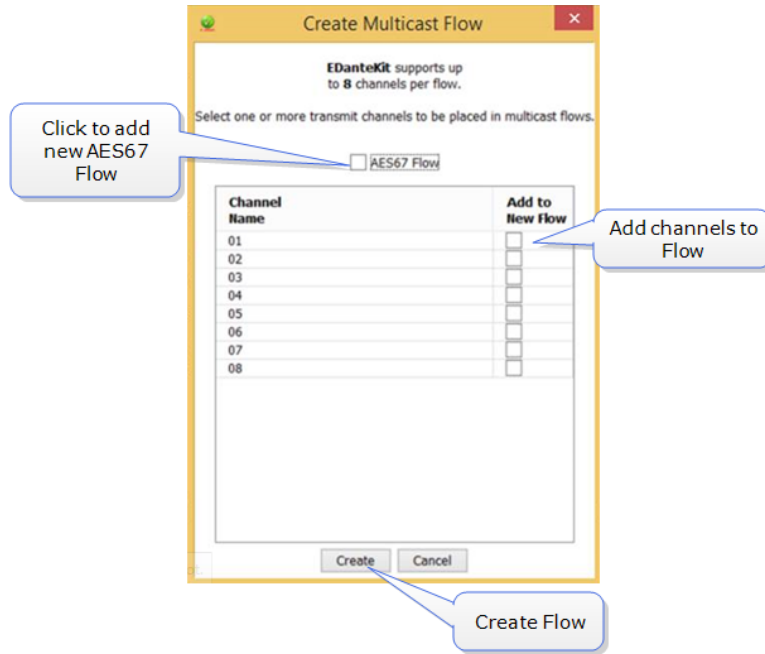

Figure 14-15 AES67 flows

- 3) Click the **Multicast** button
- 4) Create new AES67 flows as needed.





- 5) A once Flows are created, they can be seen in **Network View>Device>Transmit** in the Dante controller.

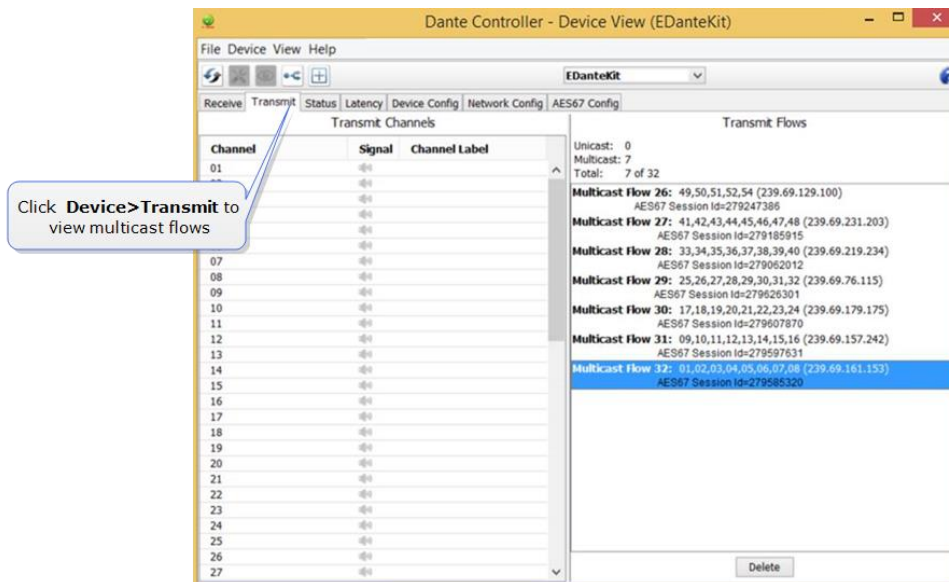

Note: Each flow can contain up to 8 channels. You can create as many flows as you need, depending on the channel capacity of your device.

- 6) The AES67 device can be seen in the **Network View** of the controller. It is shown in blue to mark its difference from the devices transmitting Dante channels.

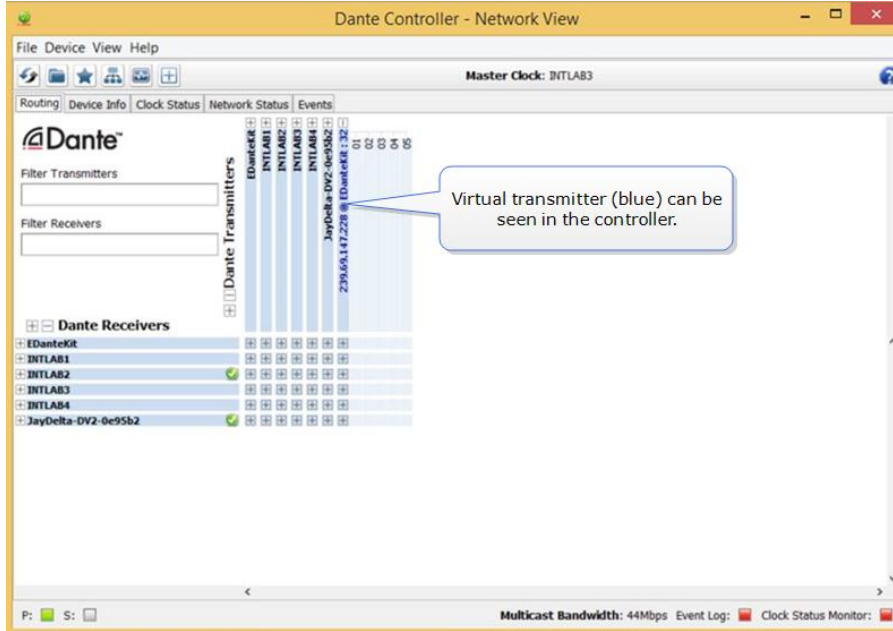

Once available in the Dante interface, AES67 flows can be viewed and subscribed to in the usual way.

If you need more information on creating an AES67 interface, please refer to Audinate and your 3rd party AES67 device documentation.

14.9 Upgrade your E-DANTE64-HX card

Upgrades for your E-DANTE64-HX card are available for both EHX and Dante firmware and are available from your Clear-Com representative.

The upgrade process for the two different modules on the card (1. EHX and 2. Dante) is different. The two processes are outlined below.

Note: When upgrading your E-Dante64 card, only use the Clear-Com supplied upgrade files for both

Note: (A: EHX) ClearCom - App, Boot, DSP, FPGA: xxxxxx.FWC files
(B: Dante) ClearCom [Brooklyn]: xxxxxx.dnt file.

To check if your firmware is up to date, open the Firmware Report in EHX.

In the EHX software, navigate to the **Layout** tab. Right click on the required matrix and select **Firmware/Firmware Report**.

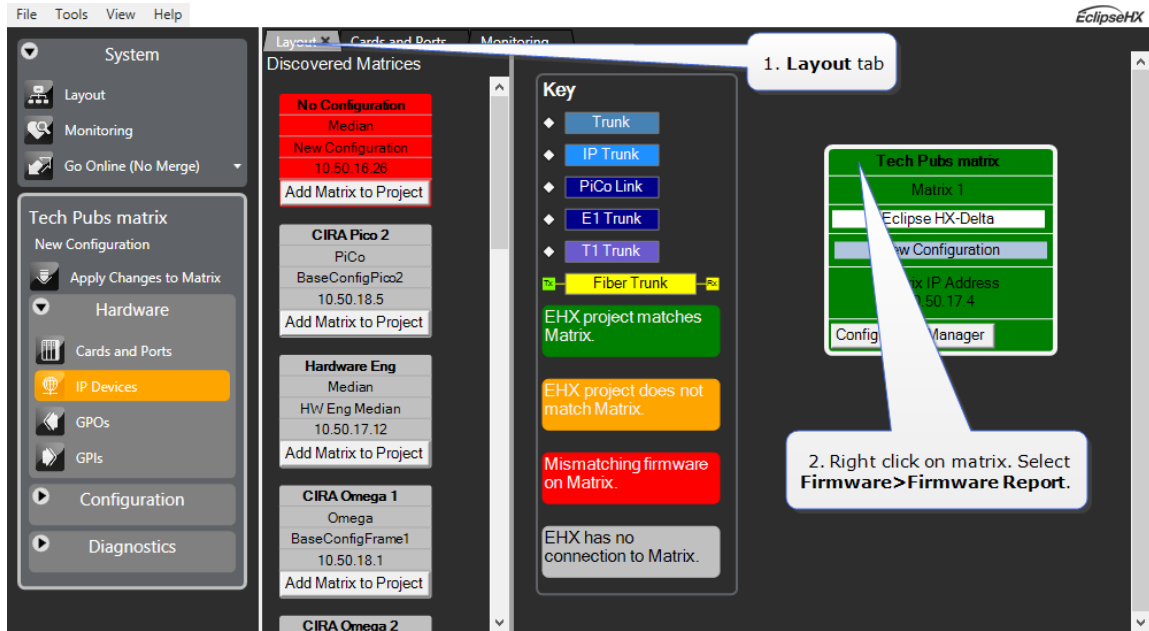

Figure 14-16 Select firmware report

14.9.1 Upgrade EHX E-DANTE64 firmware

In the EHX software, navigate to the **Layout** tab.

Right click on the matrix to be upgraded and select **Firmware>Update Firmware>Card**.

Navigate to where the E-Dante64 upgrade file is stored and click to upload.

There are 4 possible upgrade file types.

Upgrade file type	Approximate upgrade times
App.FWC	2 min. This is the most common file to upgrade and is usually labeled 'Clearcom'.
Boot.FWC	1 min
DSP.FWC	3 min. Reset card on front panel after upgrade.
FPGA.FWC	16 mins

Table 14-3 Upgrade files

While the E-DANTE64 card is being upgraded with EHX firmware, the active light (green) on the front of the device will flash at double its usual speed and the error light (red) will show. The card is ready for use when the error light is off and the status light has returned to a steady 1Hz pulse.

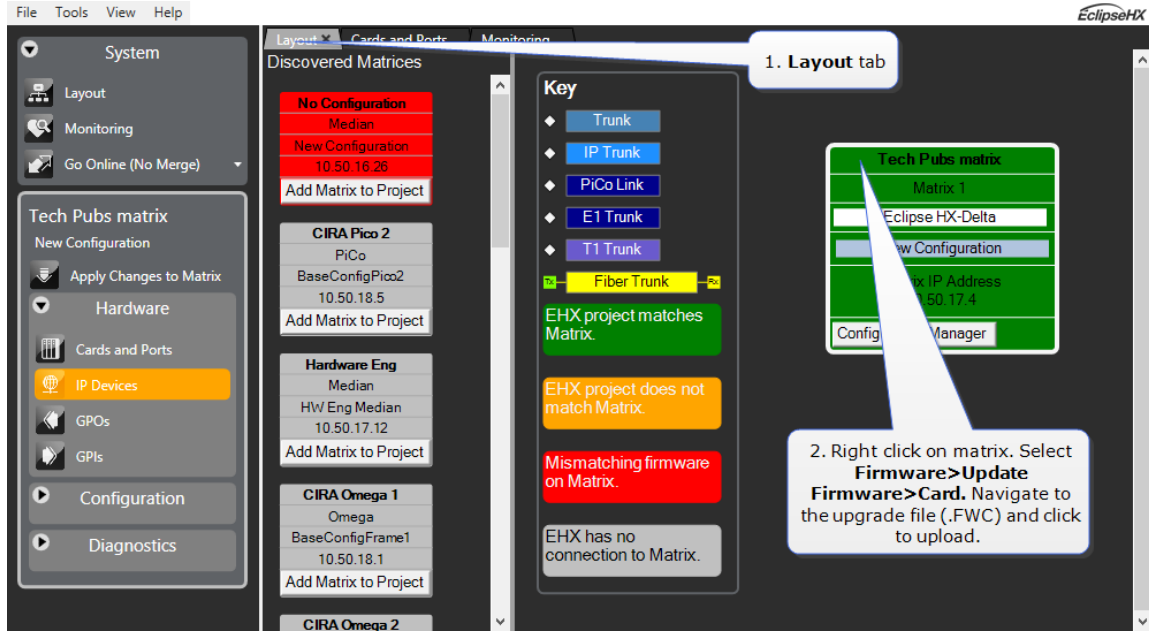

Figure 14-17 Dante upgrade

Note: The EHX component of the upgrade process for an E-DANTE64 card is the same as a MADI card.

Note: As with the MADI card, the FPGA file can be upgraded using Xilinx iMPACT programming software. For more detailed information, see section 11. *Upgrading E-MADI64 cards in the Eclipse Upgrade Guide* (available from the Clear-Com website).

14.9.2 Upgrade Dante firmware

Before updating the Dante component of your E-DANTE64 card, you must first download the Dante Firmware Update Manager from the Audinate website.

Open the Dante Firmware Update Manager and follow the instructions on the screen. The Dante firmware upgrade file (usually labeled 'Brooklyn') has a **.dnt** extension.

Note: Please disable any firewalls before upgrading the E-Dante combined Brooklyn file (.dnt) via Dante Firmware Update Manager.

Note: When upgrading firmware for the Dante component, the status light on the front of the E-Dante64 card will not change.

15 Adding and configuring an E-IPA-HX card

The E-IPA-HX card is a high-capacity internet protocol (IP) audio card. It provides up to 64 connections.

The card offers both IVC ports and Clear-Com FreeSpeak II IP Transceiver (IPT) connectivity. This can be a combination of up to 64 IP ports or FreeSpeak II wireless beltpack connections (according to license).

IVC-32 functionality (V-series panels, Directs, LQ, and Agent-IC) runs at the same time as FSII beltpacks.

The E-IPA-HX card requires EHX software 10.0 and above.

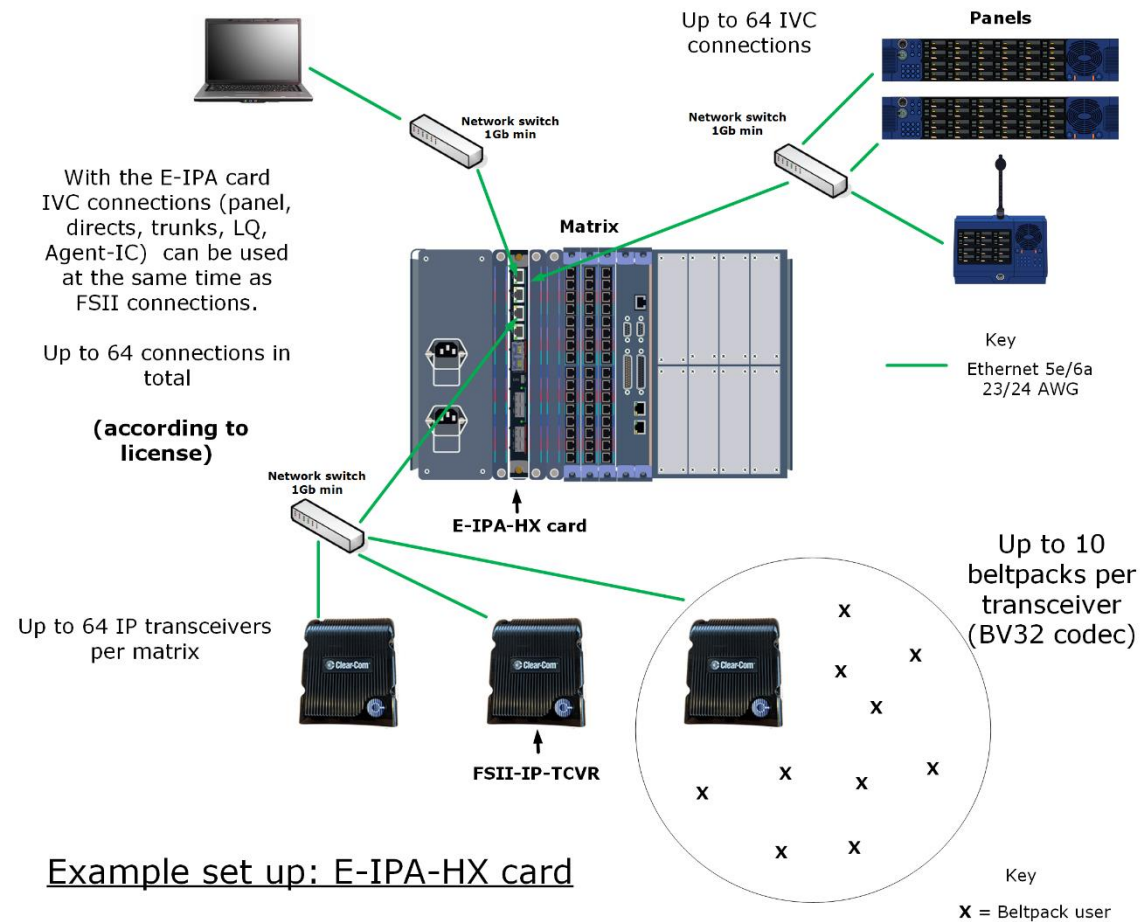

Example set up: E-IPA-HX card

Note: The configuration of IP addresses when using the E-IPA card is important. See **15.5 Network setup for the E-IPA-HX card.**

15.1 Licenses

The card operates on a license basis. You have the option to upgrade your card port capacity in increments of 16 ports. You can buy a card with a 16, 32, 48 or 64 port license.

Number of ports	Part number
16 ports	E-IPA-16-HX (1 x 16)
32 ports	E-IPA-32-HX (2 x 16)
48 ports	E-IPA-48-HX (3 x 16)
64 ports	E-IPA-64-HX (4 x 16)
16 additional ports	E-IPA-UG-16-HX

Note: 64 ports in total per card is the maximum.

When you install a new card and use the **Detect New Hardware** feature in the EHX software, the software automatically detects the number of ports that are licensed on the card. You can also select the appropriate number of ports in **Card Properties**.

For how to obtain and install licenses see the *E-IPA Card Licensing Guide*.

The front lens of your card will always show how many ports you have licensed on that card.

15.2 Card capacity

Up to 64 IVC or FSII connections, according to license. Any combination of:

- V-series panels
- LQ, LQ SIP
- Agent-IC
- Directs
- Trunks
- Up to 64 IPTs and up to 64 FS II beltpacks. Connecting an IPT does not remove any available ports, so there are potentially 64 ports that you can reserve for beltpacks regardless of how many IPT are connected to the card.

Concert is NOT supported on the E-IPA-HX card.

15.2.1 How many E-IPA cards in a Clear-Com matrix?

- Clear-Com Omega and Median matrices: up to four E-IPA cards per matrix

- Clear-Com Delta matrix: up to three E-IPA cards per matrix

Note: This is an estimate for general guidance. For a more exact calculation, refer to the *Eclipse HX System Power Calculator* (Excel spreadsheet) that comes with your EHX firmware. You can find this spreadsheet in the **Documents** folder on the firmware DVD or USB.

15.3 Adding an E-IPA-HX card (automatic discovery)

The E-IPA-HX card is automatically discovered when:

- You select the **Discover Hardware** option after the Matrix is placed on the **System Layout** from the discovery pane.
- You right-click a matrix on the **System Layout** screen, and then select **Configuration > Create New Configuration > Discover Hardware**.

15.4 Adding an E-IPA-HX card (manual)

To add an E-IPA-HX card:

- 1) In **Hardware > Cards and Ports**, navigate to an available slot number (marked **Empty**). Do either of the following:
 - Double click the slot.
 - Right click the slot and select **Set Card Type**.
- 2) A drop-down menu is displayed, listing the available card types. Select **E-IPA-HX**.
- 3) From the Card Properties screen, select the correct Port License.

It is not possible to have both E-IPA based FSII cards and EQue based FSII cards in the same Matrix. If you do so the following warning message appears:

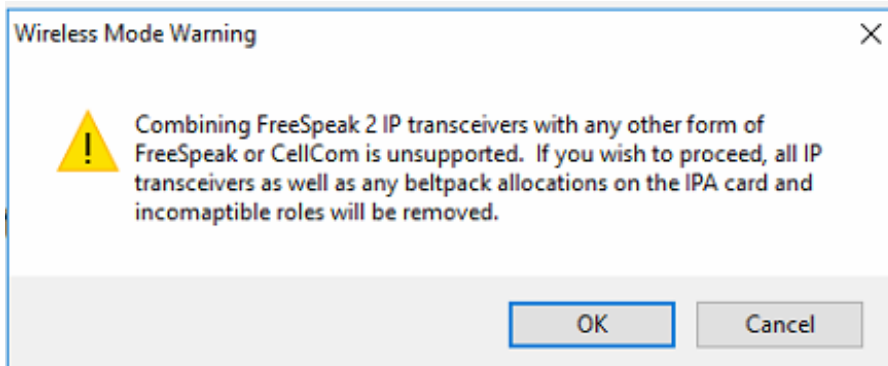

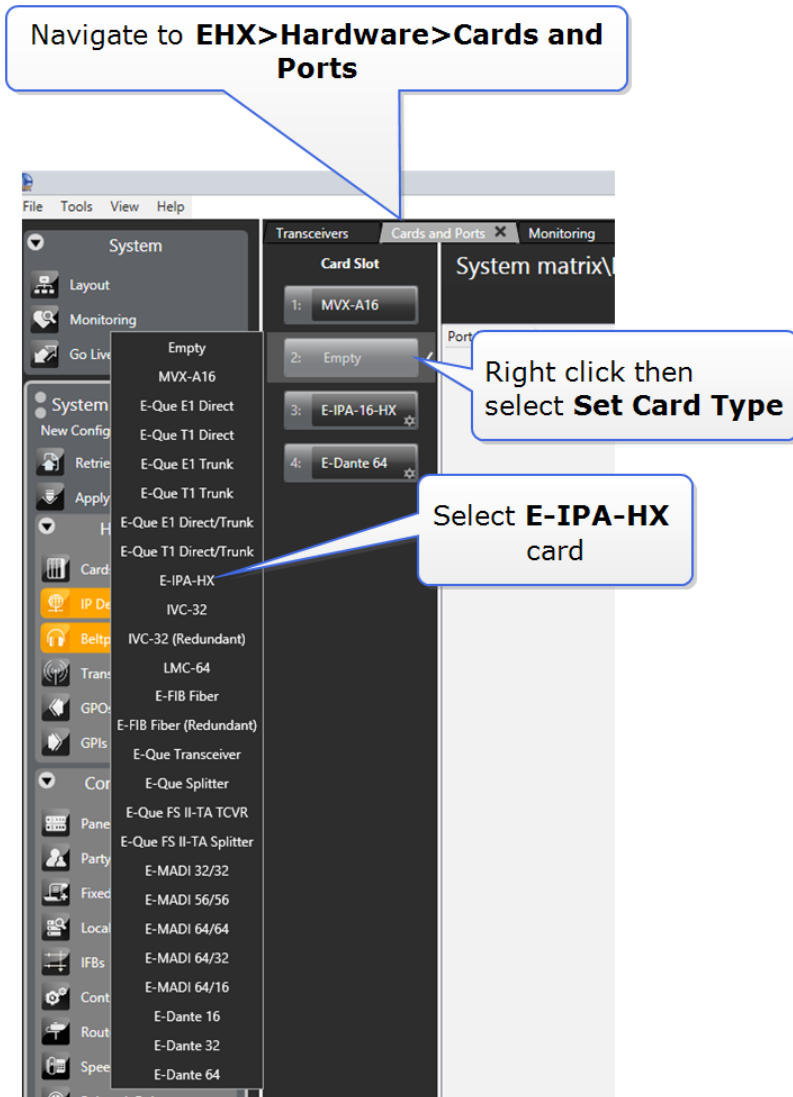

You can also use the **Detect New Hardware** feature in EHX to discover the card. Use this feature if the hardware is installed before the software is configured. This feature auto-detects the number of ports available on the card.

Note: When you add or remove a card in your configuration, the following message appears:

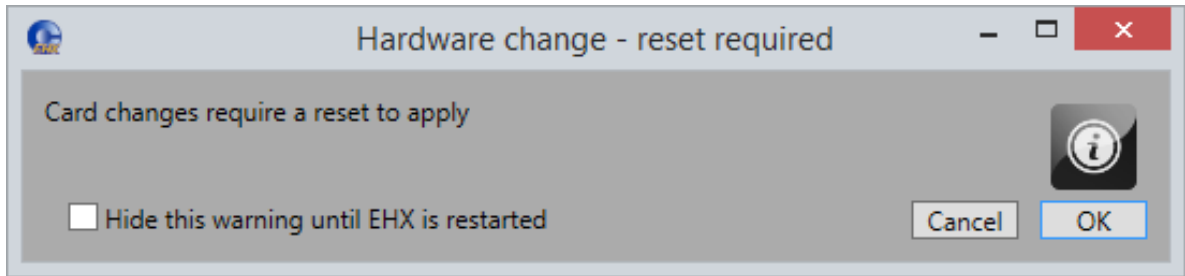

Figure 15-1 Hardware change

If your configuration contains linked matrices, the following message might appear when you apply changes to the matrix:

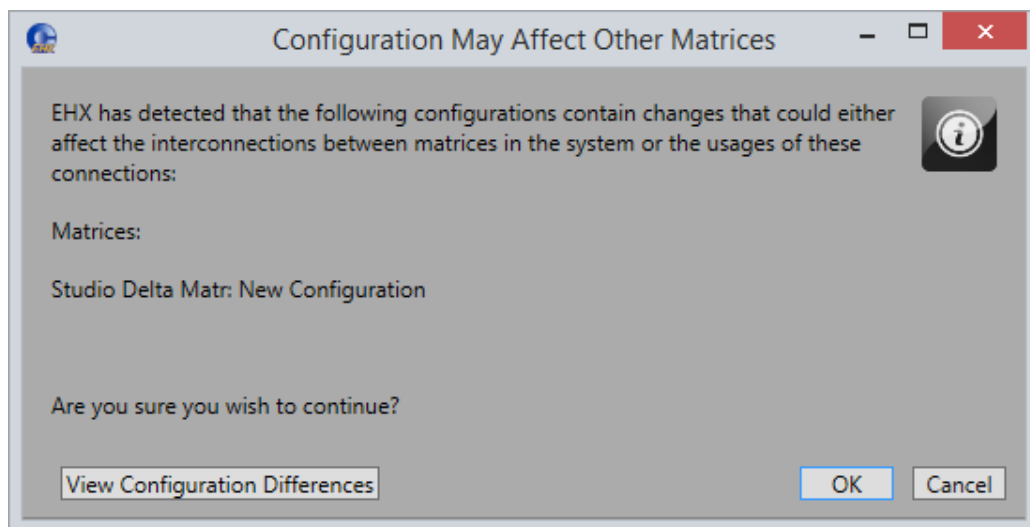

Figure 15-2 Configuration may affect other matrices

- 4) Click **View Configuration Differences** to see a list of possible interconnection issues.
- 5) Click **OK** to continue, or **Cancel**.
- 6) The E-IPA-HX Card Properties screen appears:

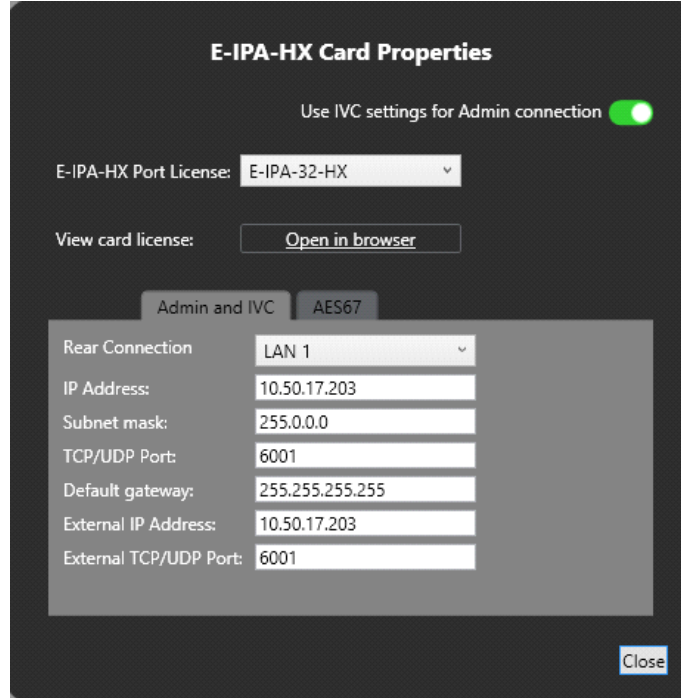

Figure 15-3 E-IPA-HX Card Properties

Change the edit fields as required, and then click **Close**.

Note: To view and edit the E-IPA-HX card properties at any time, double click on the E-IPA-HX Card Slot or right-click and select **Card Properties**.

After you have added a card, you can move it to another card slot as follows:

- 1) Right-click the card slot to be moved, and select **Move Card**.
- 2) Right-click the required empty card slot, and select **Paste Card (Move)**.
The card moves to its new position, and it maintains its configuration.

15.5 Network setup for the E-IPA-HX card

An E-IPA-HX card offers up to three available IP addresses. How these IP addresses are configured depends on how you intend to use the card.

The card properties dialog box indicates three different functions that can be spread over the 6 ports that are available on the back of the card.

- 1) Admin: Used, for example, for firmware upgrade or diagnostic data extraction.
- 2) IVC: V Series panels, Trunking, Directs, Agent-IC, LQ.

- 3) AES67: data and audio connection between the E-IPA-HX card and the IP Transceivers (IPTs).

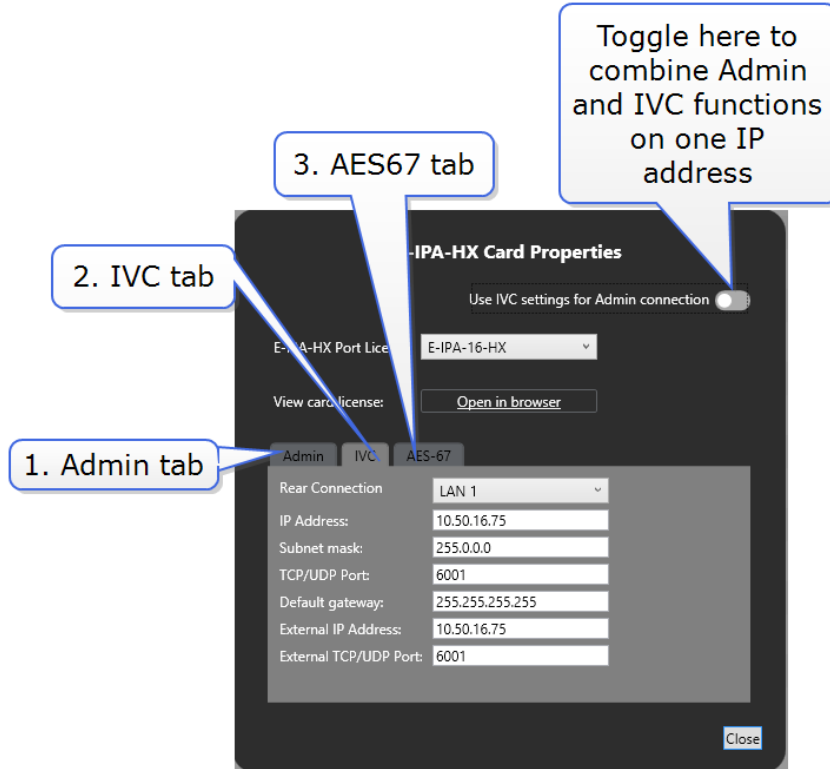

Functionality and IP ports can be combined, but Clear-Com recommends certain rules for set up to avoid loss of functionality and IP clashes.

15.5.1 Network setup for Clear-Com IVC functionality (V Series panels, Directs, Trunks, LQ and Agent-IC)

When configuring IVC functionality you must allocate a static IP address to this connection.

Note: You must configure the subnet mask to match your network topology when using a static IP address. Contact your network administrator for more information.

When using IVC functionality, the recommended setup is to combine IVC and administration functions on the same IP address (default setting).

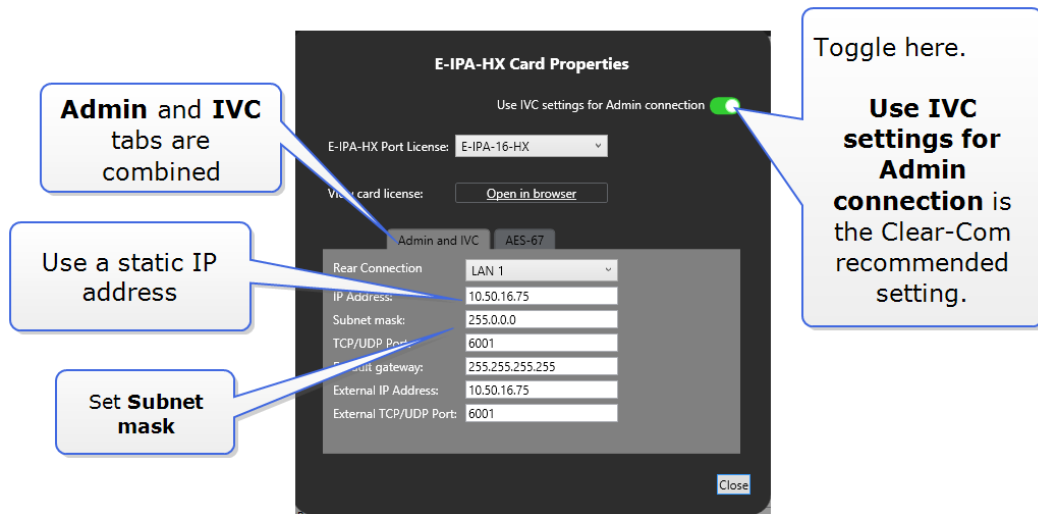

You can separate **Admin** from **IVC** connectivity, but if you do this, you must put administration functions and IVC functionality on separate subnets.

In this case, the Admin connection can be given a DHCP IP setting, while the IVC connection must have a static IP address.

15.5.2 Network setup for the FreeSpeak II IP Transceiver (IPT) with E-IPA-HX card

AES67 connections to the IPT can be on ports 1-6 (RJ45 or Fiber). Default: **LAN 3**.

- Clear-Com recommends that AES67 ports are on a separate network from the Admin and IVC ports.

- AES67 connections can work in the link-local range of IP addresses (169.254.XXX.XXX).
- When configuring an AES67 network, the network switch must have DiffServ Quality of Service (QoS) switched on.
- If the switch is capable of different profiles, select the standard AES67 profile.
- Internet Group Management Protocol (IGMP) snooping must be switched on and there must be an IGMP querier on the subnet.
- The network must be 1Gbps. A 100Mbps network does not support the amount traffic the card can generate.
- Multicast support must be enabled.
- If you use more than three switches between the PTP master and the slave, Boundary or Transparent clocks must be used.

Warning: When the IP address of the AES67 port changes, the E-IPA card automatically resets.

The screenshot shows the 'E-IPA-HX Card Properties' window. At the top, there is a toggle for 'Use IVC settings for Admin connection' which is turned on. Below that, the 'E-IPA-HX Port License' is set to 'E-IPA-16-HX'. A 'View card license' button with 'Open in browser' text is present. The 'Admin and IVC' section is active, showing 'AES-67' selected. The 'Rear Connection' dropdown is set to 'LAN 3'. The 'DHCP Enabled' checkbox is checked. The IP Address is 169.254.10.107, Subnet mask is 255.255.0.0, and Default gateway is 255.255.255.255. A 'Close' button is at the bottom right. Three callout boxes provide instructions: one points to the 'Open in browser' button, another points to the 'Rear Connection' dropdown, and a third points to the 'DHCP Enabled' checkbox.

Click here to configure a connection to a FreeSpeak IP transceiver

Select from ports 1 - 6. AES67 is usually configured on a separate LAN connection from Admin and IVC

If no DHCP server is present, a link-local address is allocated

15.5.3 Example network setup for both IVC and FSII functionality

The diagram shows a vertical E-IPA-HX card with several ports labeled LAN 1 through LAN 6, E-IPA, and E-IPG IN/OUT. Two screenshots of the 'E-IPA-HX Card Properties' configuration window are shown to the right. The top screenshot shows LAN 1 configuration with a static IP of 10.50.16.75. The bottom screenshot shows LAN 3 configuration with DHCP enabled and a DHCP IP of 169.254.10.107.

LAN 1: Admin and IVC traffic
Example IP
Static IP address: 10.50.16.75

LAN 3: AES67 traffic
Example IP
DHCP IP address: 169.254.10.107

E-IPA-HX Card Properties

Use IVC settings for Admin connection

E-IPA-HX Port License: E-IPA-16-HX

View card license: [Open in browser](#)

Admin and IVC | AES-67

Rear Connection: LAN 1

IP Address: 10.50.16.75

Subnet mask: 255.0.0.0

TCP/UDP Port: 6001

Default gateway: 255.255.255.255

External IP Address: 10.50.16.75

External TCP/UDP Port: 6001

[Close](#)

E-IPA-HX Card Properties

Use IVC settings for Admin connection

E-IPA-HX Port License: E-IPA-16-HX

View card license: [Open in browser](#)

Admin and IVC | AES-67

Rear Connection: LAN 3

DHCP Enabled:

IP Address: 169.254.10.107

Subnet mask: 255.255.0.0

Default gateway: 255.255.255.255

[Close](#)

Set network details in **Card Properties** in the EHX software

15.6 Configure the E-IPA-HX card for IVC connections

15.6.1 Card properties

This example shows how to configure IVC functionality.

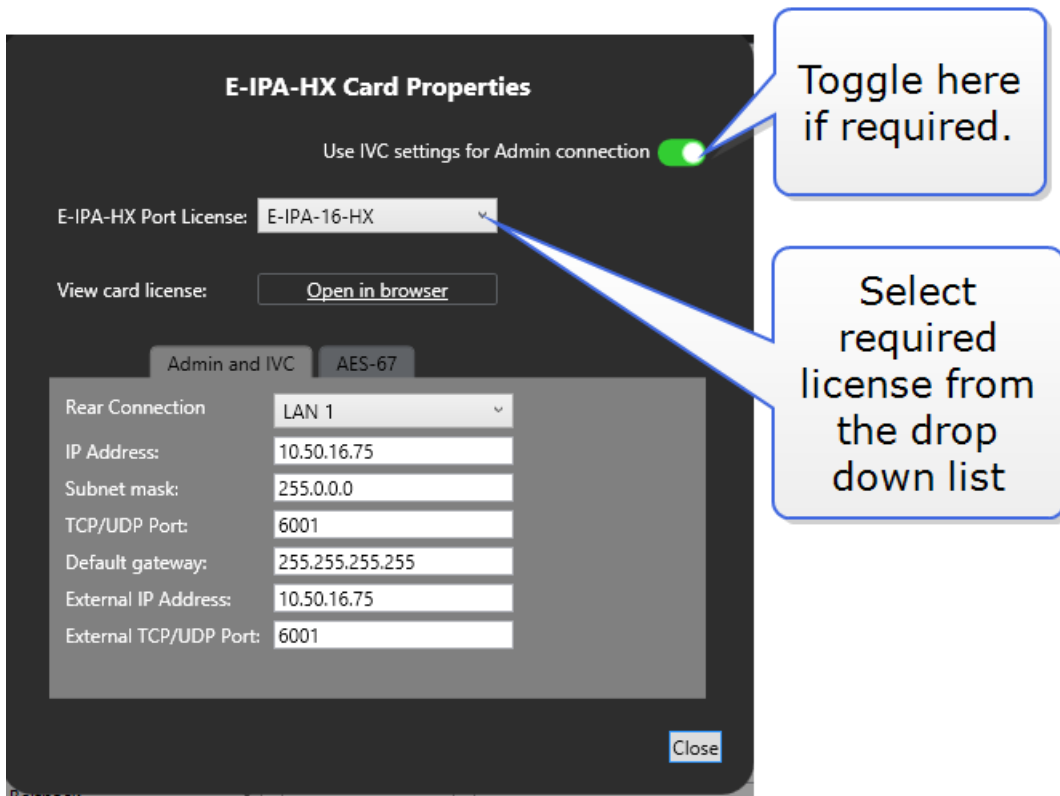

For more information, see section 15.5.1 Network setup for Clear-Com IVC functionality.

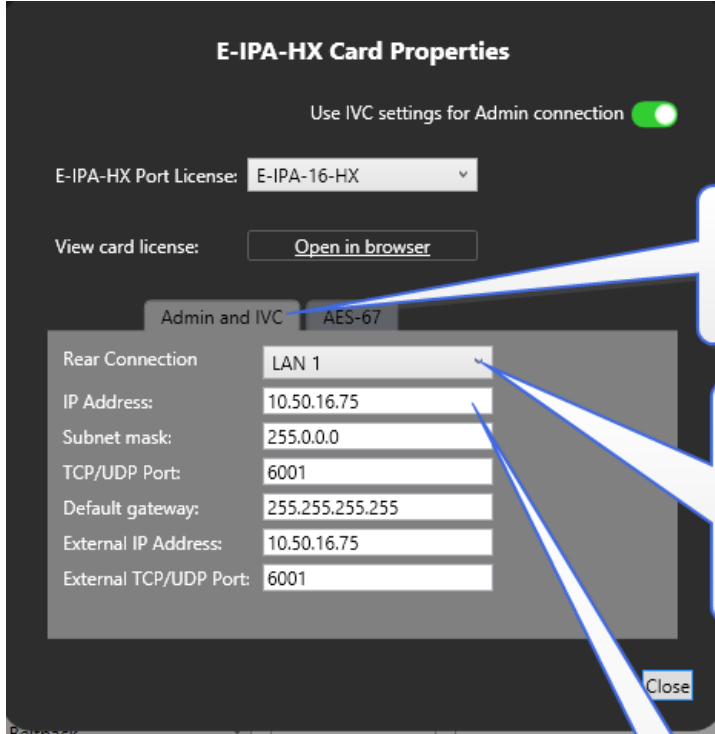

Set functionality and network settings. For IVC functionality click the **Admin and IVC** tab.

Choose the rear connector to connect to your Clear-Com peripheral devices. IVC connections are set to **LAN 1** by default.

IVC connections must be given a static IP address. When setting a static IP address you should also set the subnet mask. Speak to your network administrator if you need more information.

15.6.2 Configure ports.

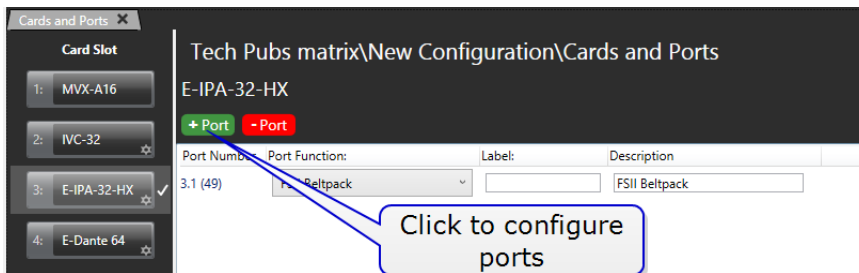

The image shows two screenshots of the E-IPA-16-HX configuration interface. The top screenshot shows the 'Port Function' dropdown set to 'Empty' and the 'Quantity' field set to '1'. A callout points to the dropdown with the text 'Select port function from the dropdown list'. Another callout points to the 'Quantity' field with the text 'How many of this type of port do you need?'. The bottom screenshot shows the 'Port Function' dropdown set to 'V 1RU Lever', the 'Description' field set to 'V 1RU Lever', and the 'Additional audio channels per panel' field set to '0'. Callouts point to the 'Auto generated label options' dropdown with the text 'Click here to automatically label ports consecutively', the 'Additional audio channels per panel' field with the text 'Click here to set Hosted Directs (panels only)', and the 'Add' button with the text 'Click **Add** to add ports'.

Note: If you are adding more than one port, you can enter values in the **Characters to Replace** and **Seed** value fields to automatically generate labels. For example, if you enter **Label 0** in the **Label** field, and then enter **0** in the **Characters to replace** and **Seed** value fields, this will automatically generate labels called **Label 1**, **Label 2**, **Label 3** up to the specified number of labels.

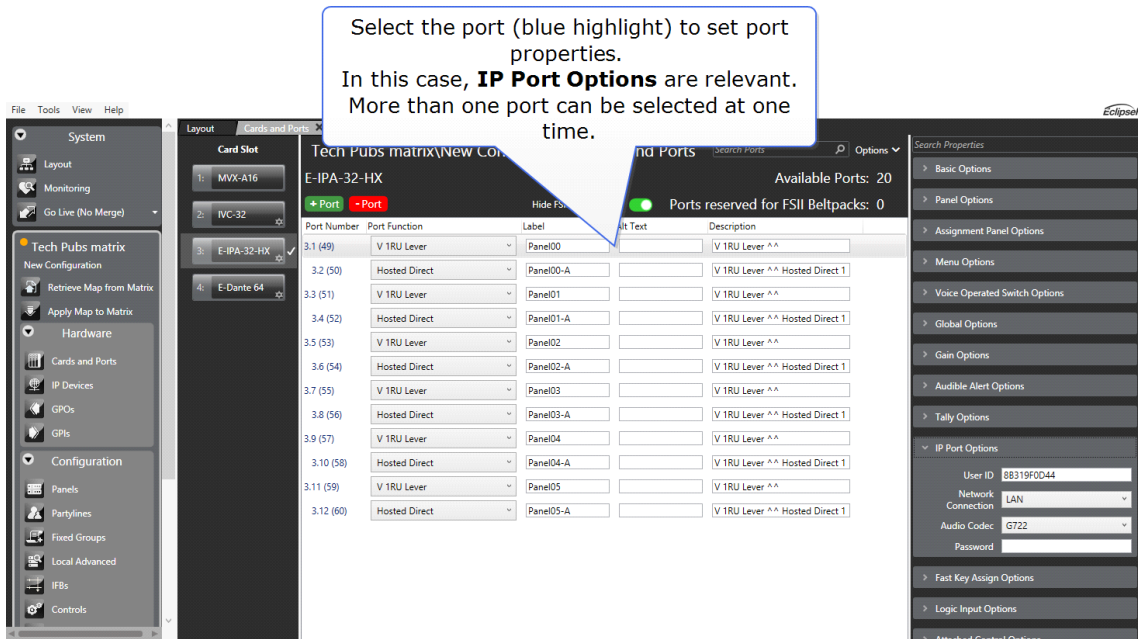
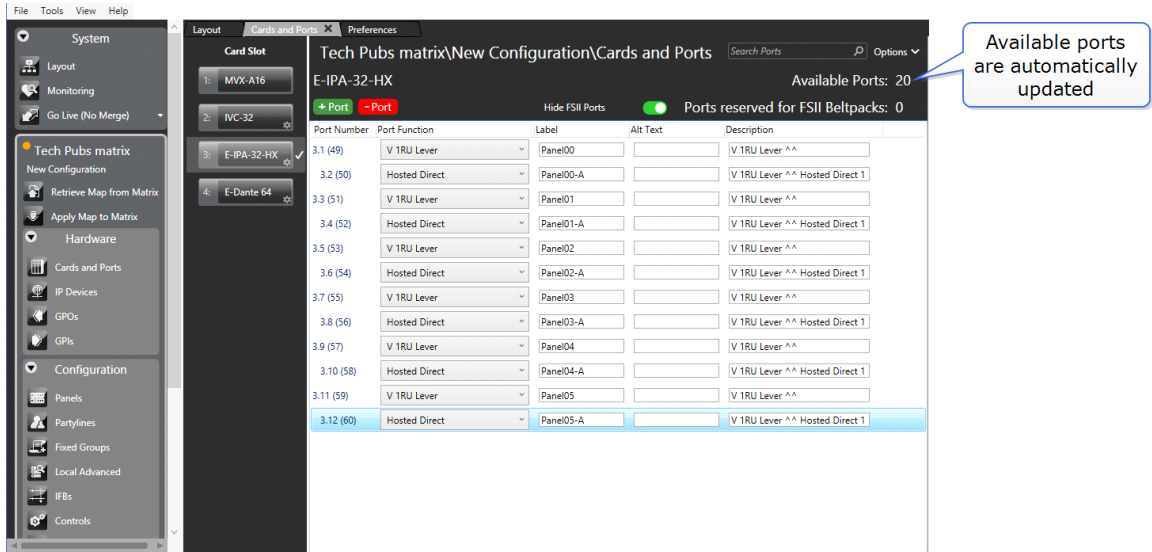

15.7 Configure the E-IPA-HX card for FreeSpeak II

15.7.1 Example set up

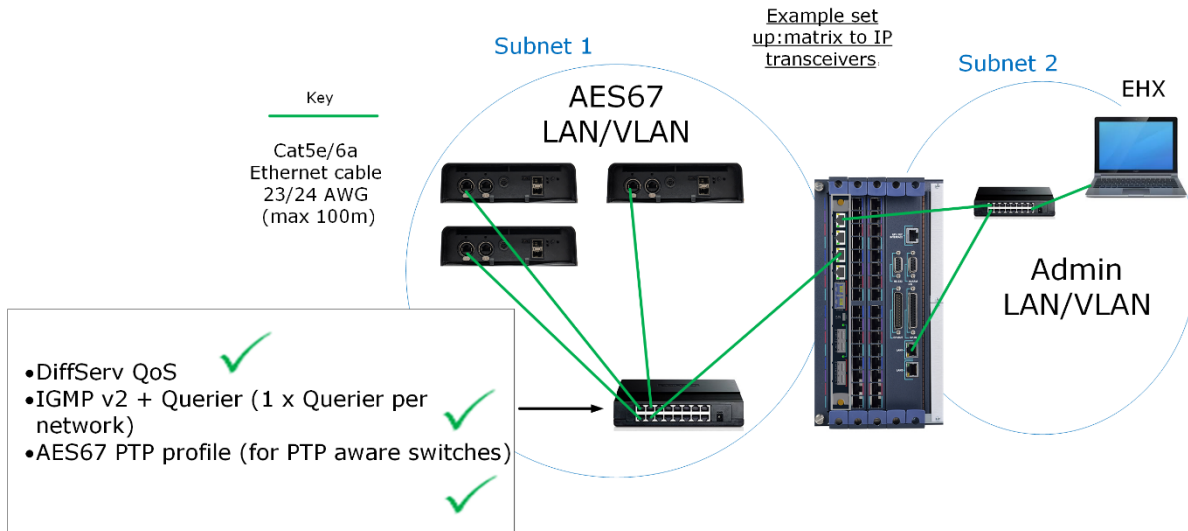

15.7.2 Set card properties

Configure the network settings in Card Properties. For more information, see section **15.5.2 Network setup for the FreeSpeak II IP Transceiver (IPT)**.

15.7.3 Beltpacks

When using FreeSpeak II on E-IPA-HX with IPTs, each beltpack takes up a matrix port. Click +Port. The following screen appears:

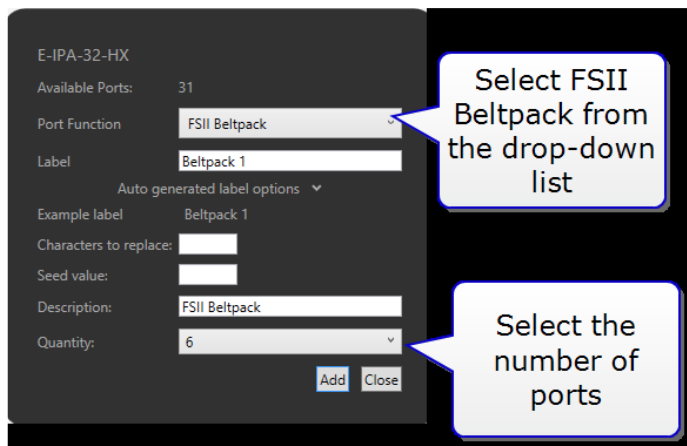

Note: The ports that are allocated to beltpacks can be thought of as a pool of ports that can be used by any FSII beltpack. You only have to allocate for the number of beltpacks you intend to have connected to the system at any one time. No allocation for spare beltpacks is required.

When at least one beltpack has been allocated to the card, a **Beltpacks** button appears under **Hardware**. Click this button to configure beltpacks in the usual way.

(Registration and Roles). For more information about configuring beltacks, see **20 Adding and configuring wireless devices**.

15.7.4 Transceivers

When at least one beltack has been allocated to the system, a **Transceivers** button appears under **Hardware**. Click this button to add and remove IPTs.

Offline configuration.

Use the **+ IP TCVR** button to add transceivers to your configuration (offline configuration).

To connect the matrix and the transceiver, input the transceiver mDNS Hostname or IP address into transceiver **Properties** and click **Apply Map to Matrix**.

Note: Using the mDNS Hostname means that the IPTs remains connected if the IP address changes.

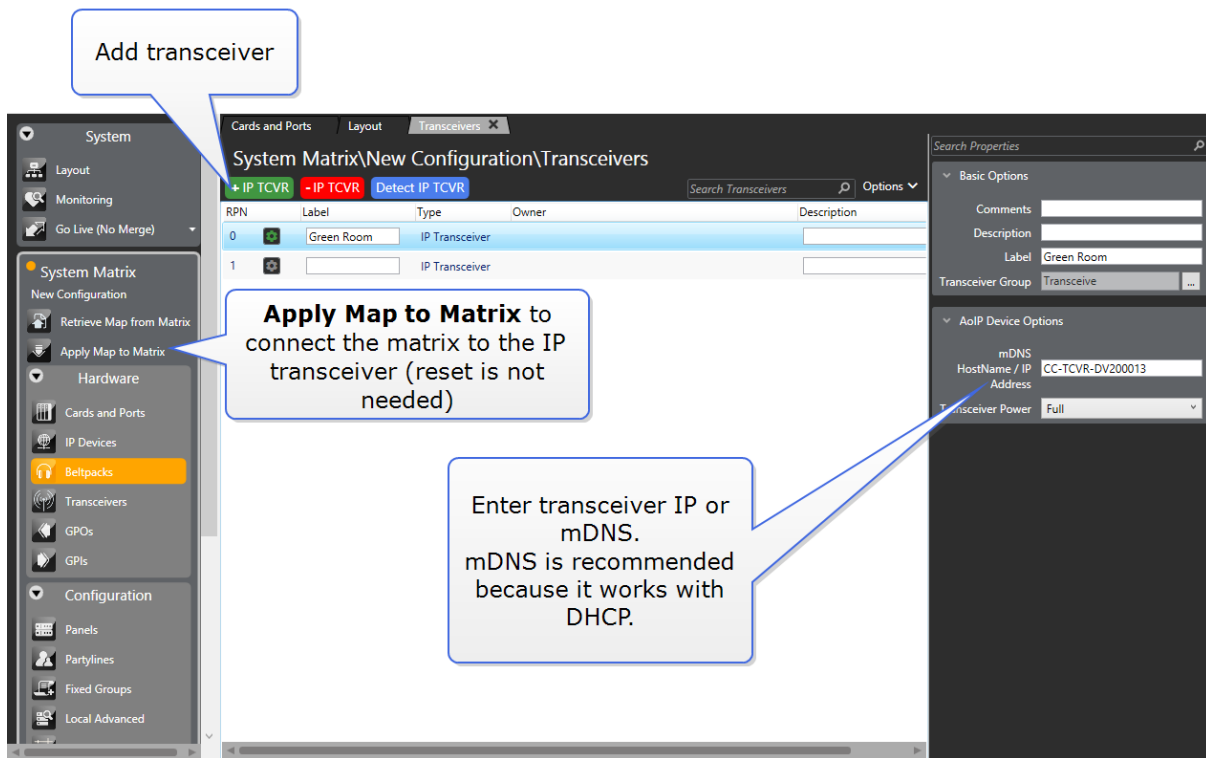

Use the **- IP TCVR** button to remove transceivers from your configuration.

Online configuration

Use **Detect IP TCVR** to find the IPTs on the network (the IPT must be on same network as IPA AES67 port, and the EHX software PC must be on the same network as the IPA admin port.). By default, the E-IPA-HX is DHCP enabled, and the IPT automatically receives an IP address.

Note: The Detect IP TCVR feature works even when the IPTs are not on the same subnet, but connected to the same Layer 2 network as the AES67 IP interface on the E-IPA-HX card. However, for connection between the transceiver and the card, the devices must be on the same subnet.

Note: If you reset an IPT to default settings, the device reverts to DHCP. To reset the IPT, press and hold the **Mode** button on the transceiver base until the status light turns red (approximately 12 seconds). This resets the AES67 Admin IP address. Ensure that the AES67 Admin and the AES67 Audio are configured to be in the same subnet.

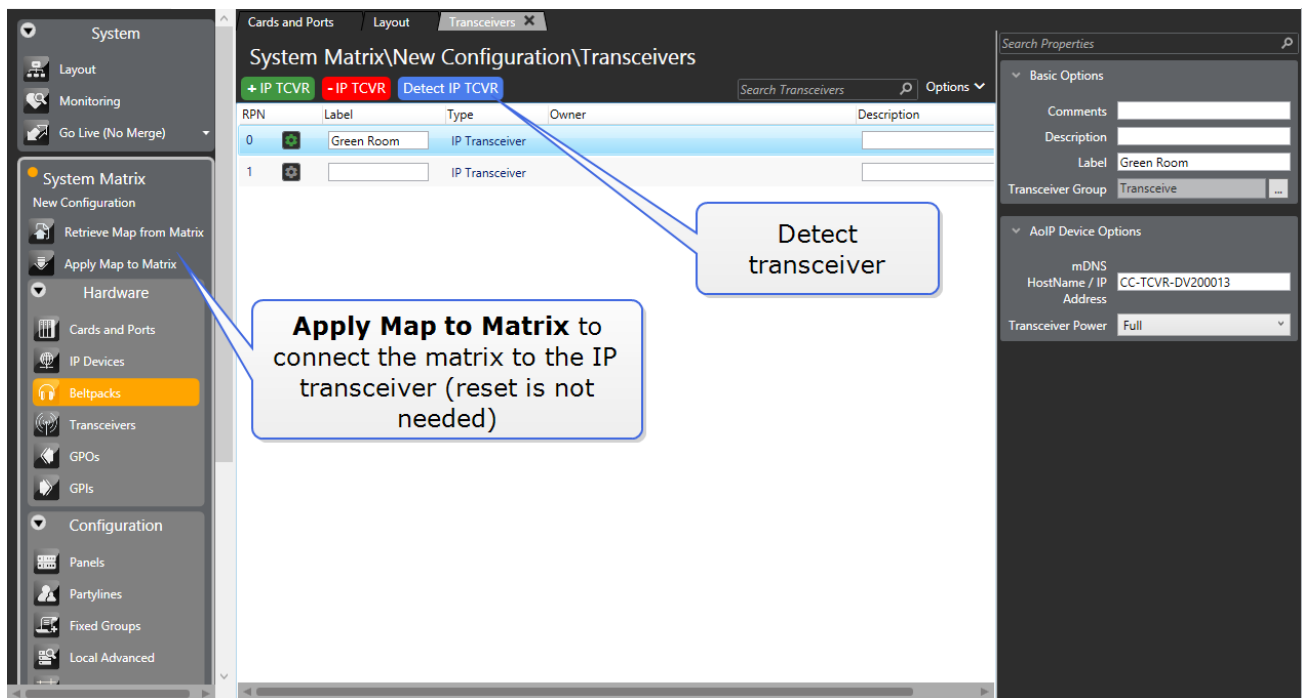

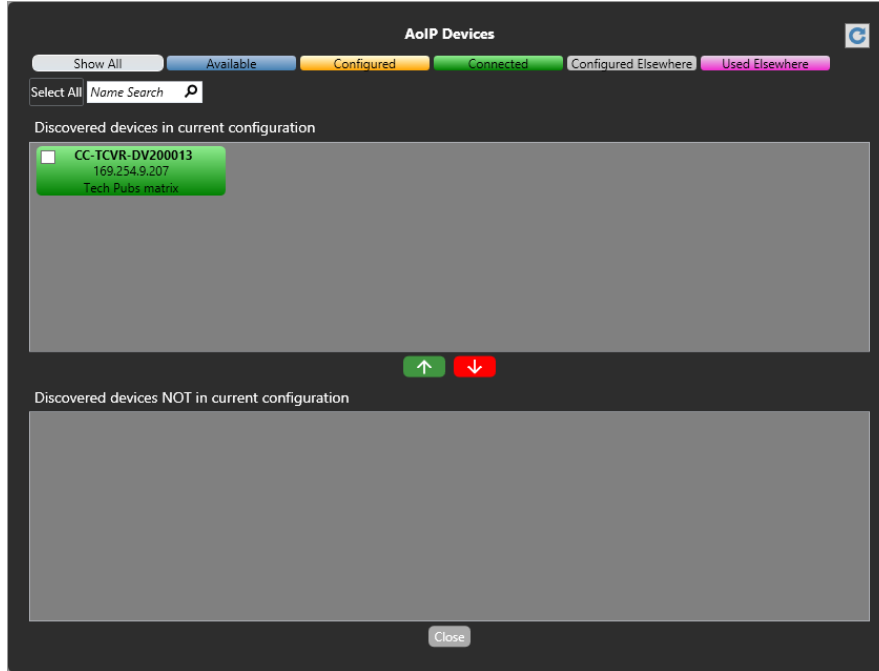

From the **AoIP Devices** screen, use the up and down arrows to add or remove matrices from your current configuration.

The color of the detected transceiver indicates:

Blue: Transceiver is available.

Amber: Transceiver is configured, but not connected to the matrix. A download is required.

Green: Transceiver is connected to the matrix.

Gray: Transceiver is connected to another matrix, but it is not online.

Purple: Transceiver is already connected to another matrix.

Static configuration

By default, both the AES67 Admin port and the AES67 Audio ports are DHCP enabled. However, you can allocate static IP addresses for an IPT.

Note: Both the AES67 Admin and AES67 Audio IP addresses must be set to static. You cannot mix DHCP and static IP addressing on the IPT.

- 1) Navigate to **Hardware > Cards and Ports**, and then double-click the card slot containing the E-IPA-HX card. The Card Properties screen appears.

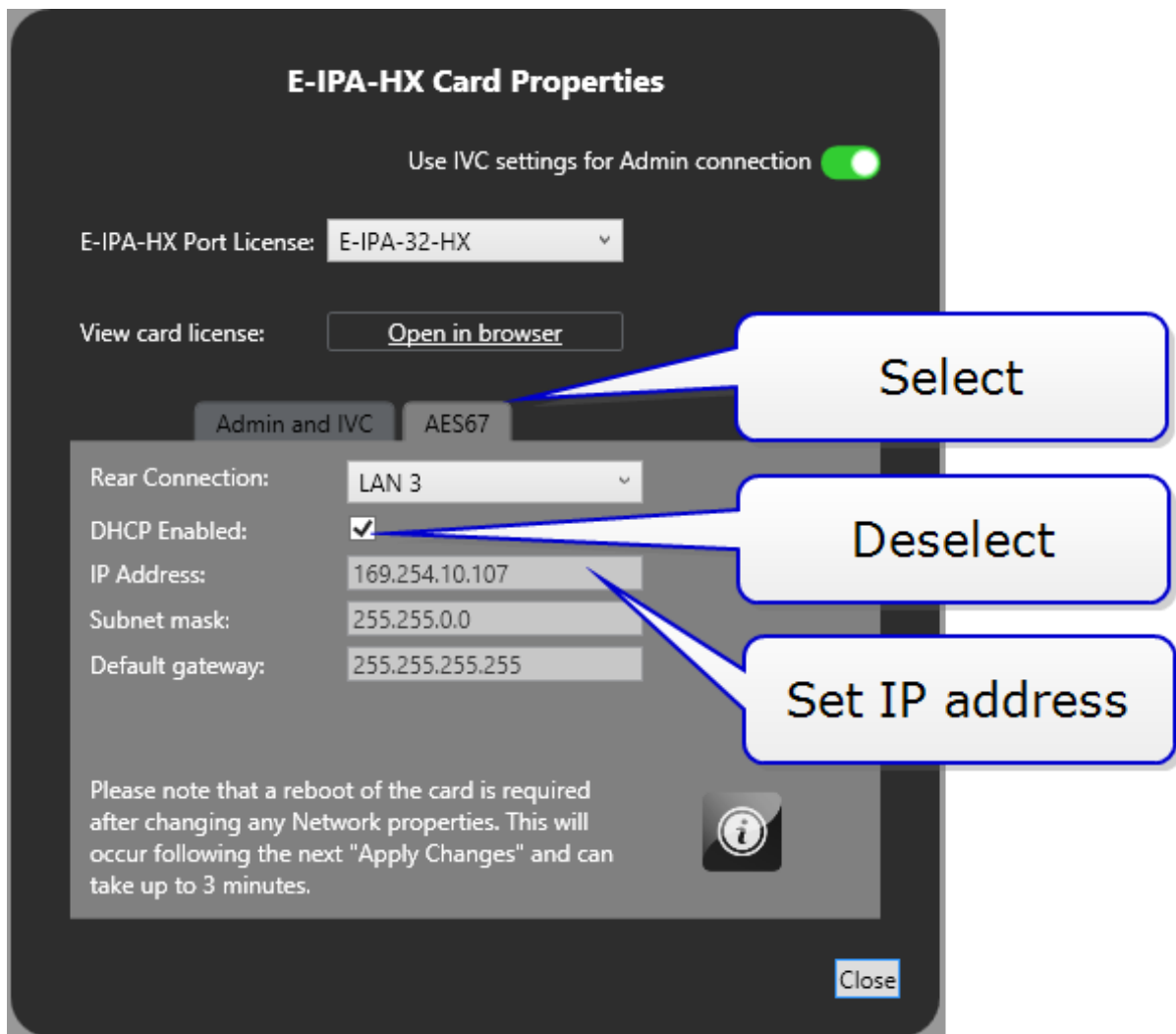

- 2) Select the **AES67** tab, and then deselect **DHCP Enabled**.
- 3) Set IP Address.
- 4) Click **Close**.
- 5) Navigate to **Hardware > Transceivers**.
- 6) Click the cog icon for the required transceiver. The Transceiver Properties screen appears.
- 7) Select **Edit**, and then deselect **DHCP Enabled** for both **AE67 Admin** and **AES67 Audio**.

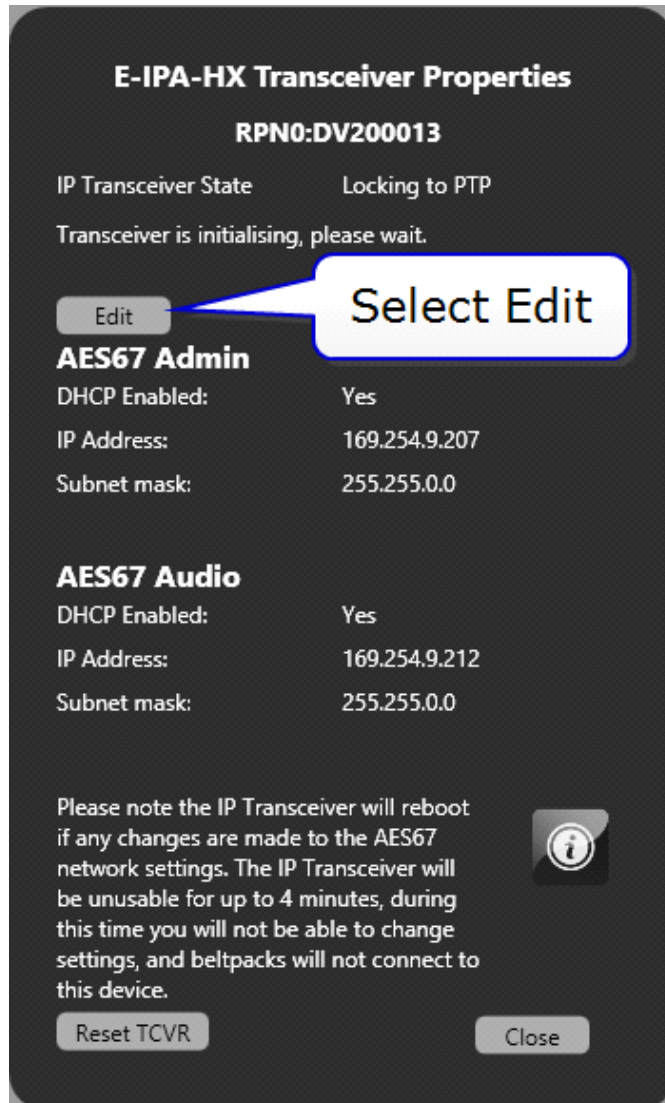

- 8) Enter the required static IP addresses for **AES67 Admin** and **AES67 Audio**.

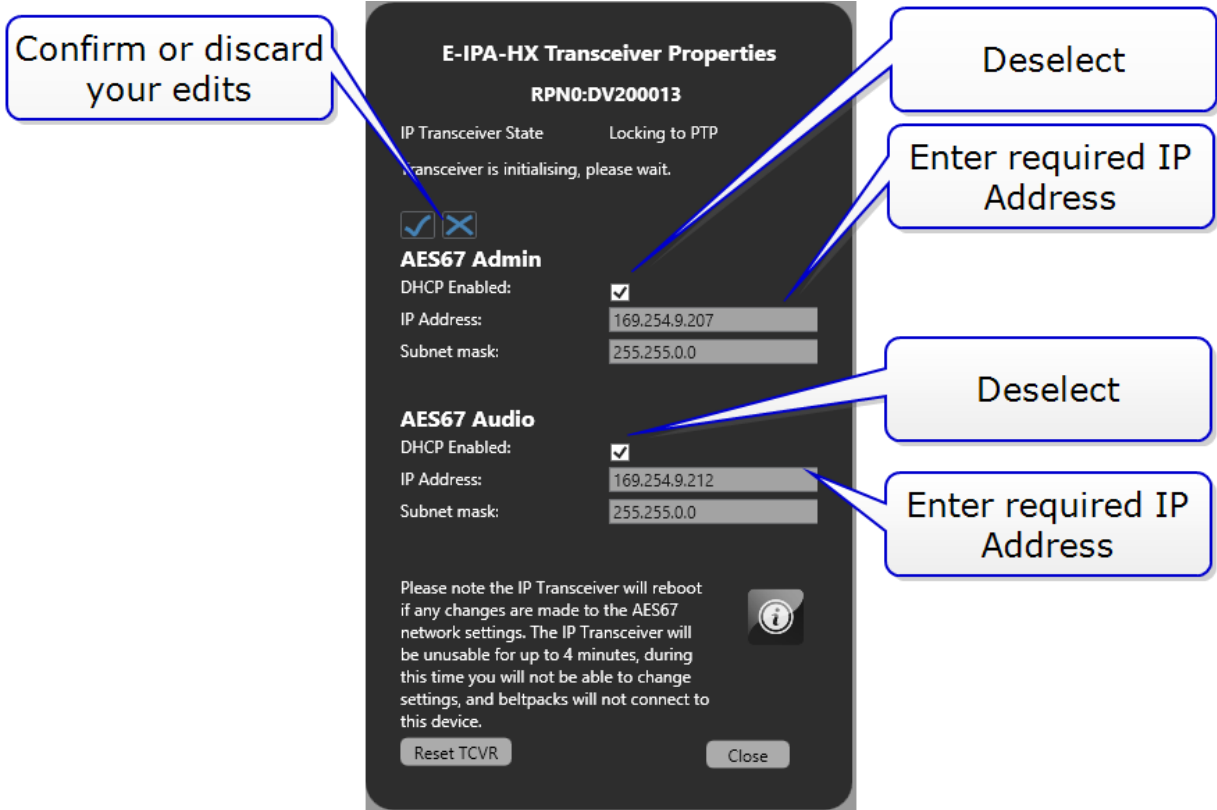

- 9) Click or to accept or discard your changes.
- 10) Click **Close**.
- 11) Click **Apply Map to Matrix**.

15.8 Convert to IPA facility

Clear-Com has a facility to convert an IVC-32 card setup to an E-IPA card setup to allow the existing card configuration details to persist (with the exception of Concert panels).

Converting to IPA allows all ports configured on an IVC card (including key references, login and IP details and so on) to be transferred to an E-IPA-HX card. This does not include Concert panels.

Note: This is a map conversion, not a hardware conversion.

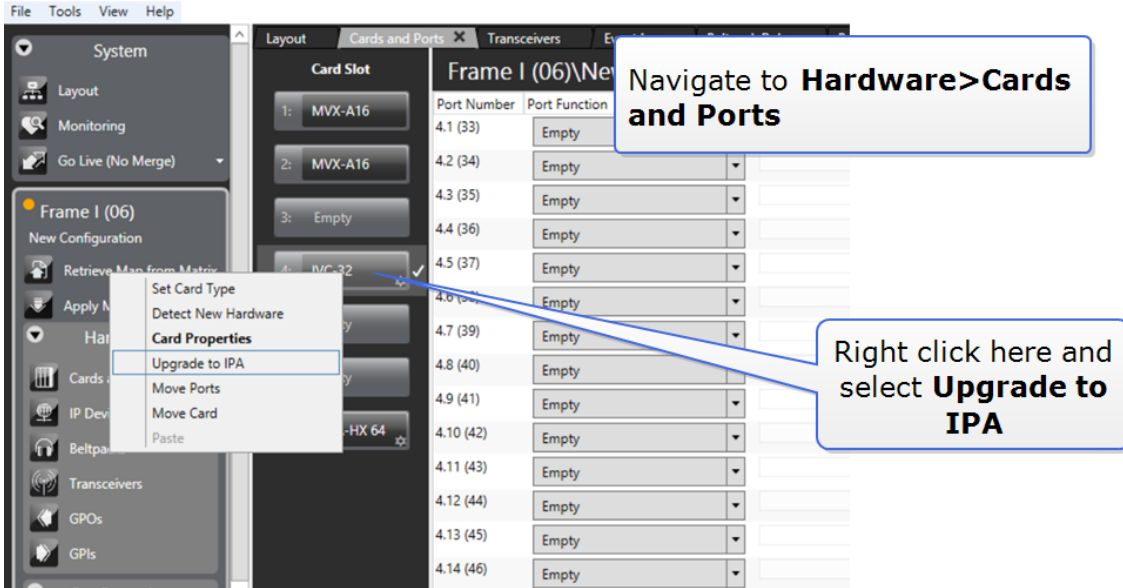

15.9 System monitoring

Note: For general information about system monitoring, see section **27.4 System monitoring**.

Navigate to **System > Monitoring** to examine the status of each E-IPA card in your matrix. An example of the monitoring screen is shown below:

```

E-IPA-HX Card
Description: Slot 3
Matrix: Victor Matrix
AES67: Running
PTP Status: Locked
PTP: Role: Master
      Master ID: 00-0E-98-FF-FE-02-F9-E4
      Local ID: 00-0E-98-FF-FE-02-F9-E4
      Master Priority: 127
      Local Priority: 127
      Offset from Master(ns): 0
      Mean Path Delay(ns): 0

Additional Details: Device Name: Not Available

Network: Admin
Rear Connection: LAN 1
State: online
IP Addr: 10.50.17.21
MAC Addr: 00:0E:98:02:F9:E1

Network: IVC
Rear Connection: LAN 1
State: online
IP Addr: 10.50.17.21
MAC Addr: 00:00:00:00:00:00

Network: AES67
Rear Connection: LAN 2
State: online
IP Addr: 169.254.10.157
MAC Addr: 00:0E:98:02:F9:E4
    
```

The following information is shown:

- AES67 Subsystem Status (text is green when there are no errors)
- PTP Status (text is green when there are no errors)
- IP Interface details

For every IP Transceiver that is configured, the following information is shown:

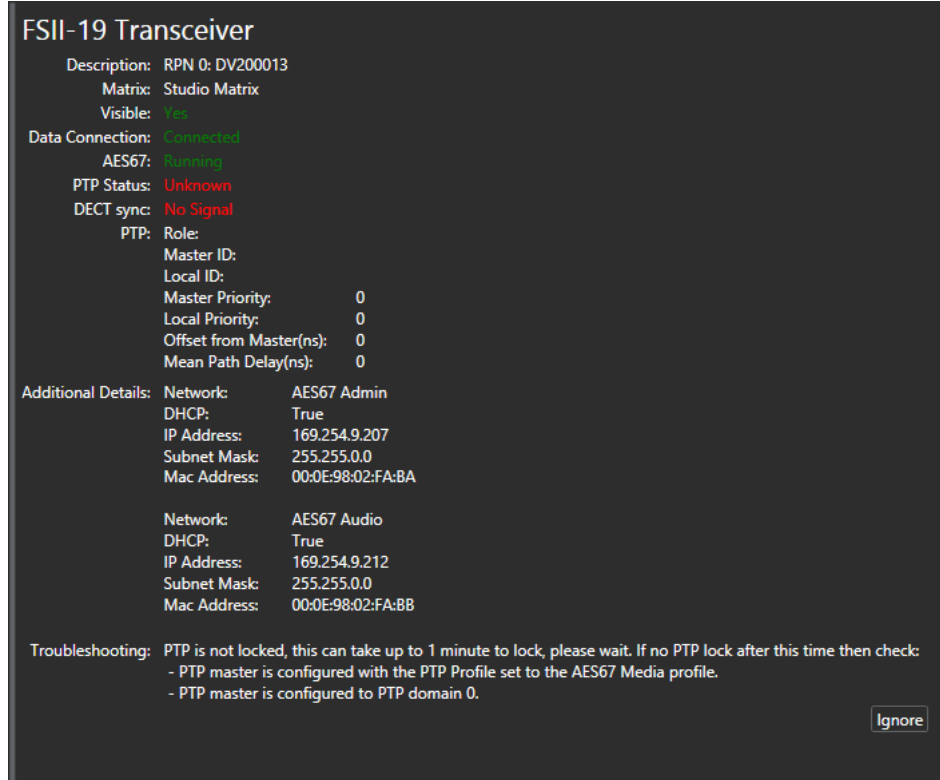

This includes:

- Status of AES67 Admin connection to Matrix. (text is green when there are no errors)
- A flag to indicate whether the IP Transceiver is visible on the network (via mDNS). (text is green when there are no errors)
- AES67 Subsystem Status (text is green when there are no errors)
- DECT Sync Status (text is green when there are no errors)
- PTP Status (text is green when there are no errors)
- IP Interface details, showing both AES67 Admin IP address and AES67 Audio IP Address.

15.10 Troubleshooting

The table below gives an overview of possible error conditions, and how to solve them.

Error Condition	Solution
<p>No data connection to IP Transceiver</p>	<p>Check the following:</p> <ul style="list-style-type: none"> • Transceiver is powered on and connected to network. • E-IPA card is powered and connected to network. • The E-IPA-HX AES67 interface and the IP Transceiver are on the same IP subnet. • Max 100m CAT5e cable distance between IP Transceiver and the nearest ethernet switch.
<p>No connection between Sitara and Minuet FPGA inside the Transceiver.</p>	<p>Transceiver is initializing. This can take up to two minutes from Transceiver power up. If after this time it is still not ready, then try repowering the Transceiver. If after the second attempt it is still not initialized, then contact Clear-Com Technical Support.</p>
<p>PTP synchronization is not established.</p>	<p>PTP is not locked. This can take up to one minute to lock, please wait. If no PTP lock after this time, then check:</p> <ul style="list-style-type: none"> • PTP master is configured with the PTP Profile set to the AES67 Media Profile. • PTP Master is configured to domain 0.
<p>No DECT sync</p>	<p>The radio is not yet synchronized. This should only take up to 10 seconds, please wait. If after this time it is still not synchronized, then check:</p> <ul style="list-style-type: none"> • PTP master is configured with the PTP Profile set to the AES67 Media Profile. • All ethernet switches have QoS and IGMP Snooping correctly configured. • Re-power IP Transceiver and if it still does not sync after the second attempt, contact Clear-com tech support.
<p>The firmware versions of the Transceivers internal components are not in a consistent state.</p>	<p>The firmware versions of the internal components within the IP Transceiver are not compatible. Re-start the firmware upgrade via the CCM to bring the versions into sync. To do this you must open a browser to the IVC/Admin address shown above.</p> <p>Note. To do this your PC must be on the same network as the IP Transceiver and it must be accessible via IP.</p> <p>EHX Firmware report will which internal components are not running the correct firmware.</p>

Error Condition	Solution
Invalid IP address	The IP Addresses on the IP Transceiver are not valid and must be changed to adhere to the following rule: IVC/Admin & AES67 IP Interfaces MUST be on the same subnet as each other.
IP conflict detected	One of the IP Addresses on the Transceiver conflicts with another Transceiver. The other Transceiver will also be in the red error state. Change the IP address to remove conflicts.

15.11 Upgrade the E-IPA-HX card

The E-IPA card must be upgraded from the EHX software.

The admin port of the E-IPA card must be on the same subnet as the PC hosting the EHX software.

1. Tools > Apply firmware

2. Select Card

3. Navigate to where you have stored the file. The E-IPA upgrade file has a .tar.gz extension.

4. Click Download. The upgrade process will take about 2.5 minutes. During upgrade the status light on the front card will flash at a rate of twice per second.

15.12 Upgrade the IP Transceiver

- 1) Right-click on the Frame in the Layout window, and then select **Firmware > Update Firmware**. The Update Firmware Wizard appears.
- 2) Select **Next**. The following screen appears:

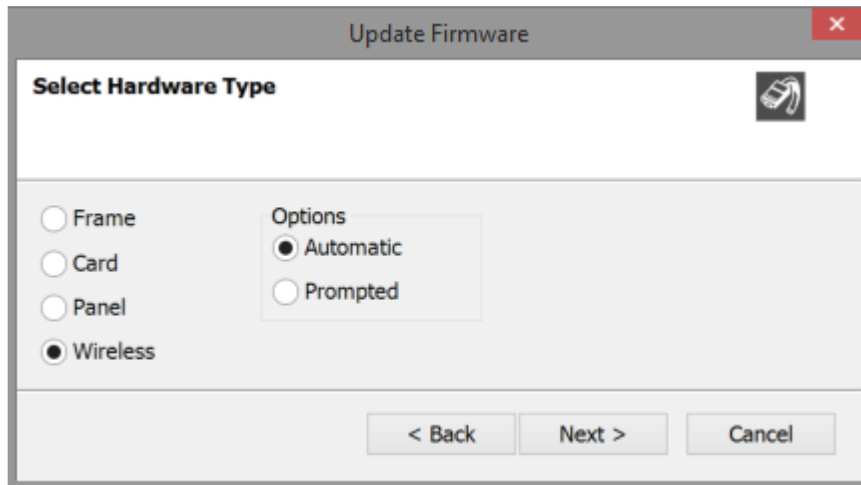

Note: For IP Transceivers, the **Auto/Promoted** radio button is always set to **Auto**.

- 3) Select the **Wireless** radio button.
- 4) Select **Next**, and then browse to the upgrade file (.fww) and select **Open**. The upgrade file is loaded to the transceiver, and the transceiver restarts.

You can track the status of the download in the EHX Event Log.

You can also upgrade the IP Transceiver using a USB memory stick. For more information, see the FreeSpeak II Integra User Guide.

16 General Purpose Inputs and Outputs

General Purpose Inputs and Outputs (GPIOs) enable you to configure a matrix input or output that triggers an external device. For example, a switch could form an input to the matrix that triggered a matrix event, or a panel key could trigger an output that operated a warning light in a studio.

The Eclipse HX matrix has eight General Purpose Inputs (GPIs) and eight General Purpose Outputs (GPOs) on the processor card and these are automatically added to EHX in the Matrix Hardware screen as module 0. You can add further GPIs and GPOs to the system using GPI-6 and RLY-6 modules respectively. These interface modules fit into slots in the matrix frame.

16.1 General Purpose Inputs (GPIs)

To reach the GPI screen, select **Hardware > GPIs**.



Figure 16-1 GPIs

16.1.1 Adding and removing GPI-6 modules

If you want to increase the number of GPIs, add one or more GPI-6 modules.

To add or remove GPI-6 modules:

- 1) Open **Hardware > GPIs**.

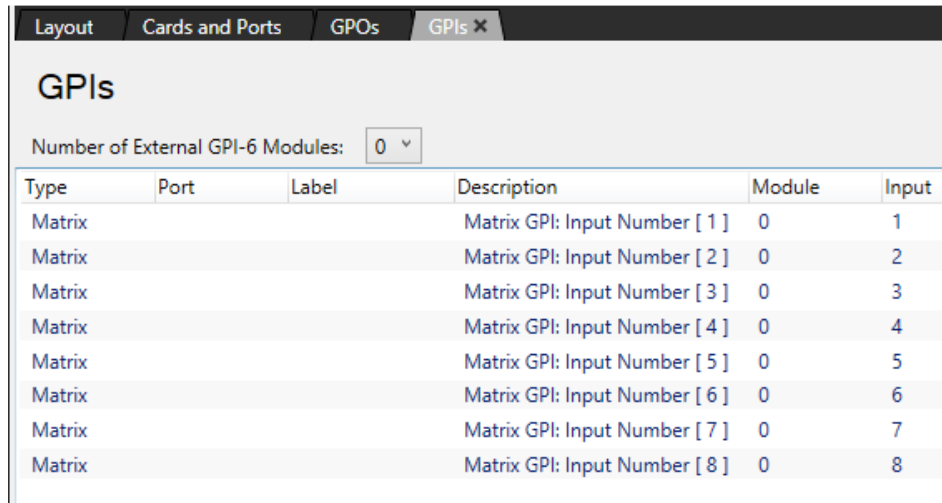

Figure 16-2 GPI-6 modules are added/removed from the GPI screen

- 2) The counter next to Number of External GPI-6 modules displays the current number of GPI-6 modules. To display a drop-down list of numbers, click the counter.
- 3) If you select a higher number than the current number, new GPI-6 modules are added. Six new GPIs are added per module.

If you select a lower number than the current number, GPI-6 modules and their associated GPIs are removed.

For more information about GPI-6 modules, see the GPI-6 Manual, available on the Clear-Com website.

16.1.2 Configuring GPIs

To configure either a matrix or GPI-6 input:

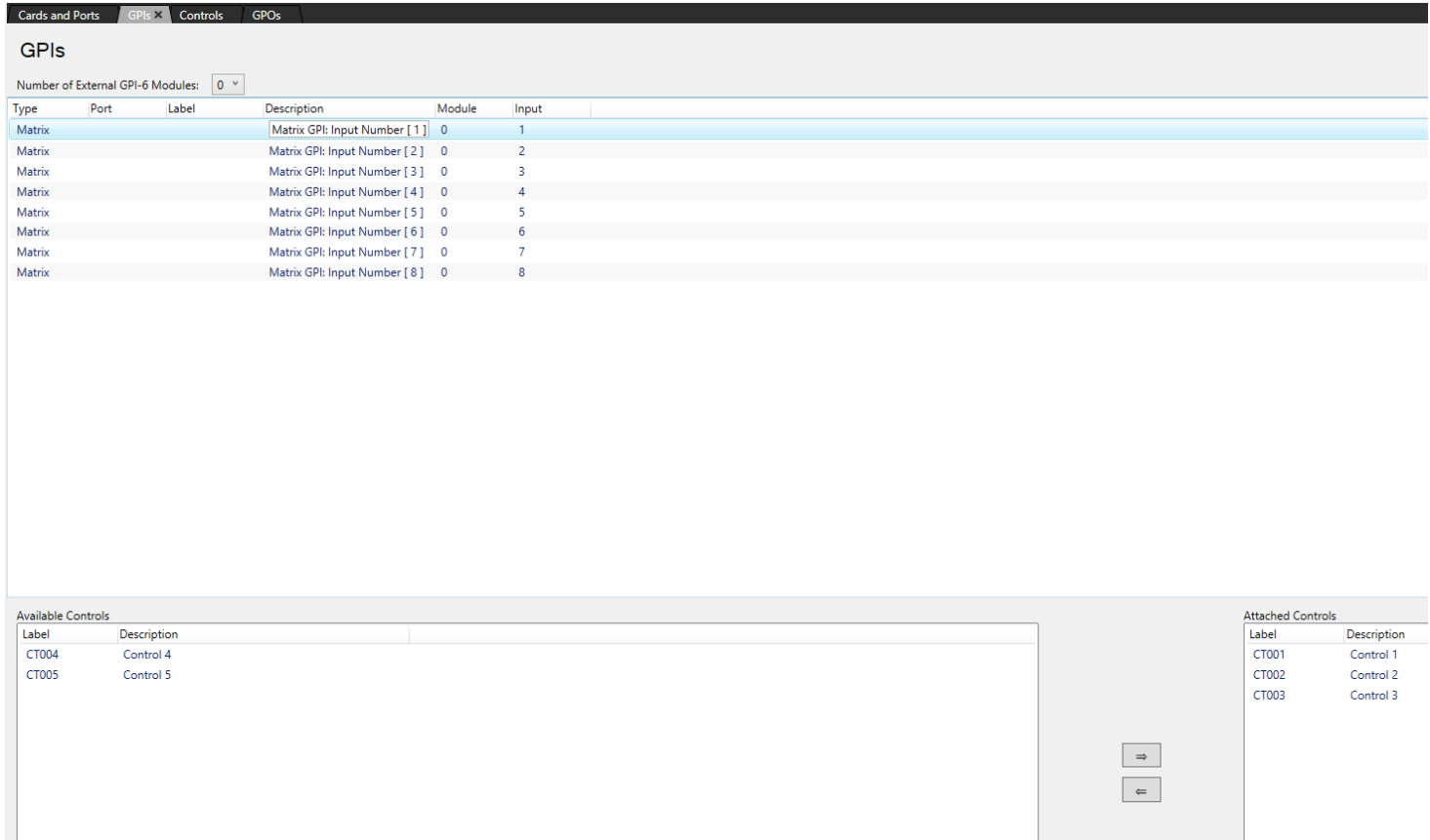

Figure 16-3 GPI full screen

- 1) Identify the input number to be used from the GPIs screen.
- 2) Click the row to highlight it.
- 3) From the **Available Controls** list, select the required Talk label.
- 4) To transfer the label to the **Attached Controls** list, do either of the following:
- 5) Click the => arrow.
- 6) Double click the label.
- 7) To detach the Talk label from the GPI, select the required label in the **Attached Controls** list.
- 8) To detach the label, do either of the following:
 - Click the <= arrow.
 - Double click the label.

Note: When using an IMF-3 frame the GPI-6 cable should be connected first to the matrix GPI data connector on the rear of the CPU Card before connecting any RLY-6 cards.

Note: For information about controls, see section **18.3 Controls**.

16.2 General Purpose Outputs (GPOs)

Note: Panel Relays are also managed from this screen, but are added and removed automatically when panels are managed from the cards and ports screen. Some of the panel relays of the IP V-Series are used by the V-Series application locally when the panel hosts secondary channels and the hosted port application is set to 2-way radio, HelixNet or Partyline. These GPIOs can additionally be used from this screen in which case the logic is OR'd with that of the V-Series application.

To reach the GPO screen, select **Hardware > GPOs**.

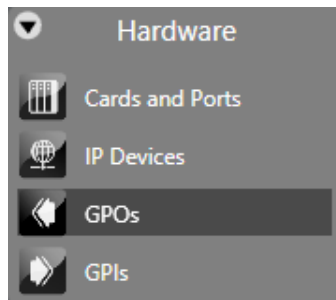

Figure 16-4 GPOs

GPOs								
Type	Port	Label	Description	Relay Information	Activate With Talk	Activate With Listen	Module	Output
Panel	1		AUX Panel Rly	Pnl AUX	<input checked="" type="checkbox"/>	<input type="checkbox"/>		2
Panel	1		IFB Ex1 Panel Rly	Pnl IFB1	<input checked="" type="checkbox"/>	<input type="checkbox"/>		60
Panel	1		IFB Ex2 Panel Rly	Pnl IFB2	<input checked="" type="checkbox"/>	<input type="checkbox"/>		61
Matrix			Matrix Relay: Output [1]	Matrix Relay: Output [1]	<input checked="" type="checkbox"/>	<input type="checkbox"/>	0	1
Matrix			Matrix Relay: Output [2]	Matrix Relay: Output [2]	<input checked="" type="checkbox"/>	<input type="checkbox"/>	0	2
Matrix			Matrix Relay: Output [3]	Matrix Relay: Output [3]	<input checked="" type="checkbox"/>	<input type="checkbox"/>	0	3
Matrix			Matrix Relay: Output [4]	Matrix Relay: Output [4]	<input checked="" type="checkbox"/>	<input type="checkbox"/>	0	4
Matrix			Matrix Relay: Output [5]	Matrix Relay: Output [5]	<input checked="" type="checkbox"/>	<input type="checkbox"/>	0	5
Matrix			Matrix Relay: Output [6]	Matrix Relay: Output [6]	<input checked="" type="checkbox"/>	<input type="checkbox"/>	0	6
Matrix			Matrix Relay: Output [7]	Matrix Relay: Output [7]	<input checked="" type="checkbox"/>	<input type="checkbox"/>	0	7
Matrix			Matrix Relay: Output [8]	Matrix Relay: Output [8]	<input checked="" type="checkbox"/>	<input type="checkbox"/>	0	8
Panel	1		Mute Panel Rly	Pnl Mute	<input checked="" type="checkbox"/>	<input type="checkbox"/>		3

Figure 16-5 GPOs Screen

16.2.1 Adding RLY-6 modules

If you want to increase the number of GPOs, add one or more RLY-6 modules.

To add or remove RLY-6 modules:

- 1) Open **Hardware > GPOs**.
- 2) The counter next to Number of External RLY-6 modules displays the current number of RLY-6 modules. To display a drop-down list of numbers, click the counter.
- 3) If you select a higher number than the current number, new RLY-6 modules are added. Six new GPOs are added per module.
- 4) If you select a lower number than the current number, RLY-6 modules and their associated GPOs are removed.

16.2.2 Configuring GPOs

In **Hardware > GPOs**, use the checkboxes to set whether the relay output is activated with talk and or listen.

THE CONTROL MANAGER SCREEN IS USED TO CREATE AND CONFIGURE CONTROLS THAT CAN TRIGGER THE RELAYS.

16.2.3 Panel Auxiliary and Panel Mute

The Available and Attached windows have tabs for the various types of functions, allowing them to be filtered for ease of selection. Two of the tabs are **Panel AUX relays** and **Panel mute relays**.

These functions correspond to these relay outputs in the I-Station documentation. In the case of V-Series panels the output relays are labelled as 1 and 2. The correspondence between the labels in EHX and the panel hardware is:

- Panel mute relay - relay output 1.
- Panel AUX relay - relay output 2.

17 Panel programming

From the **Panel Programming** screen (in the **Configuration** menu), you can assign talk and listen labels to panel keys, assign labels to expansion panel keys, configure assignment panels, stack keys and set key specific functions.

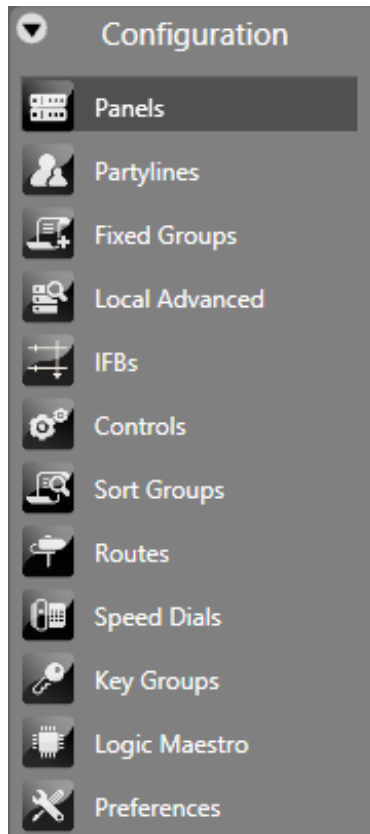

Figure 17-1 Configuration menu

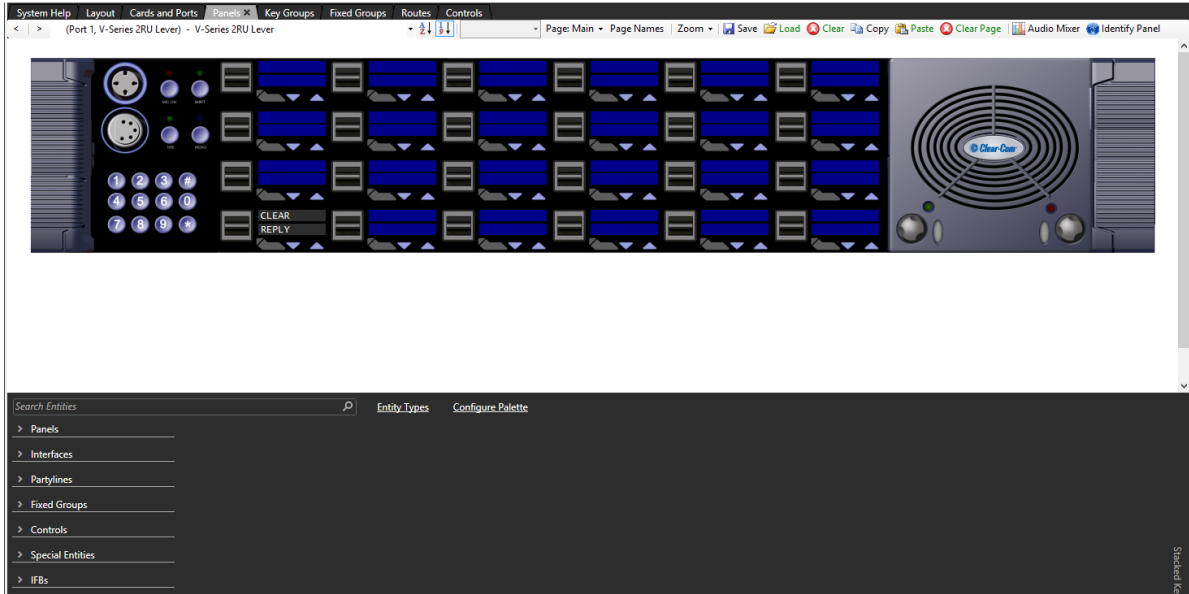
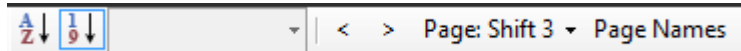

Figure 17-2 Panel Programming Screen

17.1 The panel programming screen

The **Panel Programming** Screen is split into three areas.

17.1.1 Top



The top area contains a ribbon that enables you to:

- Select from a scrollable list of connected intercom panels
- Sort the scrollable list alphabetically or numerically.
- Select and name shift pages. You can also see how many keys are currently assigned to each shift page. Left and right arrows allow you to move between shift pages.

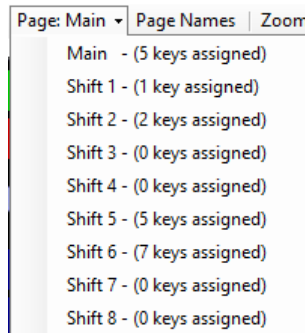

Tip: You can also select shift pages by pressing Ctrl + shift page number.
Ctrl + 0 returns to the main page.

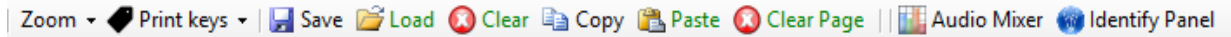

- Zoom in and out
- Print key labels
- Save, load, clear, copy and paste key layouts
- Clear all keys
- Select the Audio Mixer (see section **23 Audio Mixer**).
- Identify a panel (only in Go Live mode). This causes the panel currently being edited to flash the panel buttons or LEDs red and display **IDENTIFYME** in the bottom left display. To use this facility, monitoring must be enabled using the **Monitor** button on the EHX toolbar. This facility is only available for V-Series panels. The **Identify Panel** button is greyed out for other panel types.

17.1.2 Middle

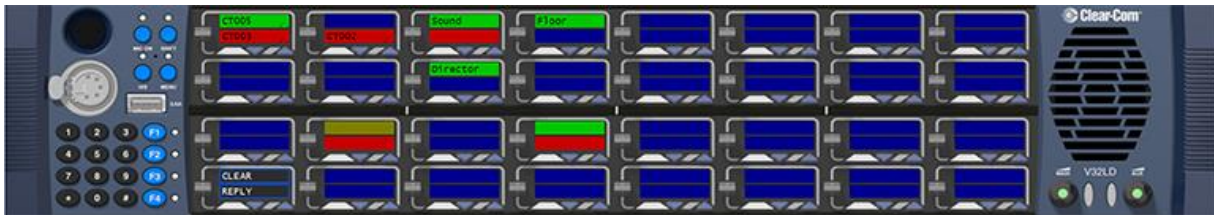

Figure 17-3 Middle area

The middle area provides a mimic of the intercom panel, and is the area where labels are programmed onto the panel selectors. This area also provides access to configure Expansion Panels to host Panels.

Note: Expansion panels can only be added or removed in Cards and Ports.

17.1.3 Lower

In the lower area, you can find:

- The Palette, consisting of a list of all the matrices currently in the project. Expand each matrix to list all the entities that it contains, such as panels, interfaces and partylines.
- The Stacked Keys area. This can be expanded or collapsed. For more information about stacked keys, see section **17.3 Stacked keys**.

17.2 The Palette

The Palette lists all the entities that are present in the configuration. Entities can be:

- Panels
- Beltpack Roles
- Interfaces
- IFBs
- Partylines
- Route Monitors
- Controls
- Fixed Groups
- Sort Groups
- Key Groups
- Special Entities

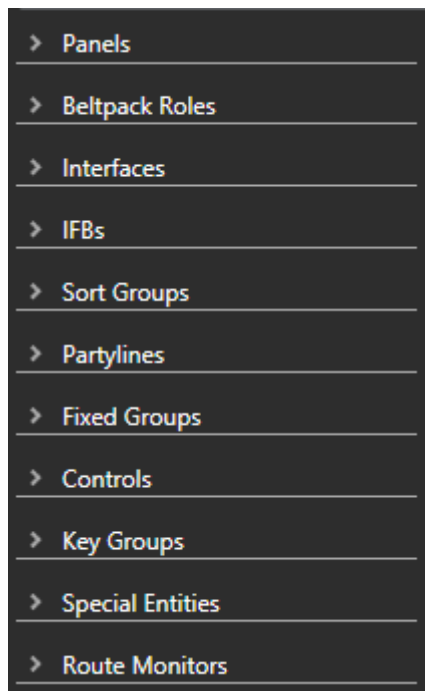

Figure 17-4 List of entities

Click on the left arrow to expand the entity.

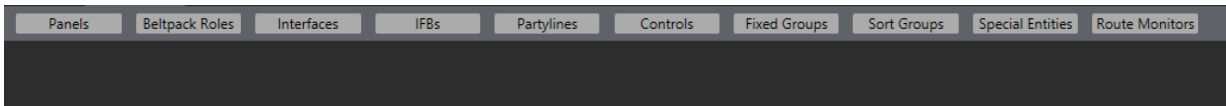

Figure 17-5 Expanded list of entities

17.2.1 Filtering for entities

You can also filter for any entity type. To do so:

- 1) Select **Entity Types**.
A list of entity types displays.



- 2) Select the required entity to filter.

Note: You can use the CTRL key to filter for more than one entity.

A list of filter entities appears.

To remove all filter, click **Filters Applied**.

Note: You can also apply filters from the **Configure Palette** screen.

17.2.2 Searching for entities

Enter a key word into the Search box. Use an asterisk (*) to denote a wild character

Note: The search is not case sensitive.

17.2.3 Configuring the Palette

Click **Configure Palette**. A list of options displays.

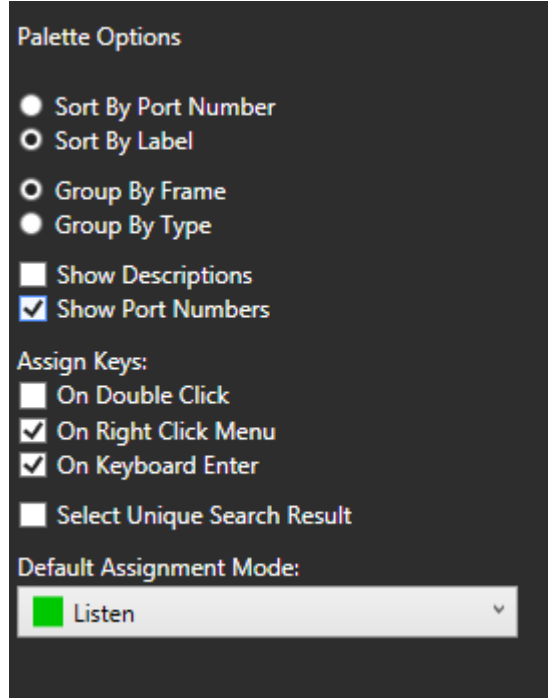

Figure 17-6 Palette Options

Palette Options

- **Sort By Port Number** - sorts entities by port number.
- **Sort By Label** - sorts entities by label
- **Group By Frame** - groups entities by matrix first, then by entity type.
- **Group By Type** - groups entities by type first, then by matrix.
- **Show Descriptions** - shows the entity description.
- **Show Port Numbers** - shows the entity port number.

Assign Keys

- **On Double Click** - double click an entity to assign it to the first free key on the panel. To determine the assignment mode, see section **Default assignment mode**.
- **On Right Click Menu** - right click an entity to display a menu. The menu displays the appropriate assignment types for the panel.
- **On Keyboard Enter** - When searching entities, press Enter to assign the first search result to the first free key on the panel. To determine the assignment mode, see section **Default assignment mode**.

Select Unique Search Result

This option automatically selects a search item, if that item is the only search result. To determine the assignment mode, see section **Default assignment mode**.

Default assignment mode

This option determines the key type for entities that are assigned to panel keys using:

- **Talk** - sets a talk from the panel to a destination with no automatic listen to the destination.
- **Listen** - sets a key to listen to the source without talking to the destination at the same time.
- **Talk and Listen** - sets a talk key with listen.
- **Dual Talk and Listen** - sets a dual talk and listen key (only on pushbutton panel types). This make the pushbutton activate a TALK on a press and hold and LISTEN with a short press on the same pushbutton.
- **Forced Listen** - sets a key with permanently made listen.
- **Talk and Forced Listen** - sets a talk key with permanently made listen.

17.3 Stacked keys

Stacked Keys functionality is the ability to add more than one Talk label to a single selector of an intercom panel.

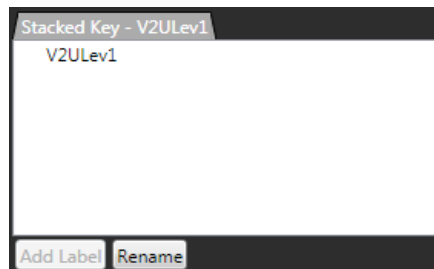

Figure 17-7 Stacked Keys Screen

17.3.1 Creating a stacked key

To create a stacked key:

- 1) Open the Panel Programming screen.
- 2) Select the panel where the stacked key is to be created

- 3) Either programme a Talk or Listen label to the panel or identify a Talk or Listen label that has already been programmed onto the panel.
- 4) On the mimic of the panel, place the mouse cursor over the required Talk label.
- 5) Double click the Talk label.
- 6) The Talk Label appears in the Stacked Key area (the bottom right window). Use the arrow to expand or collapse this area.
- 7) Drag the mouse cursor over to the Talk Labels window
- 8) Click the required label
- 9) In the Stacked Key window, select the **Add Label** button.
- 10) Repeat steps 7 to 9 for the required amount of Labels.

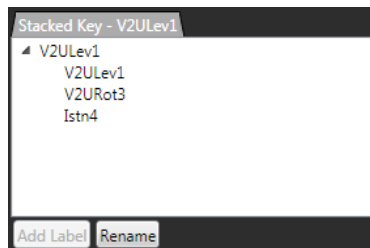

Figure 17-8 Stacked Key Label Order

The order of the labels on the stacked key runs from the last (bottom) key in the list to the first (topmost) key in the list.

17.3.2 Removing labels from a stacked key

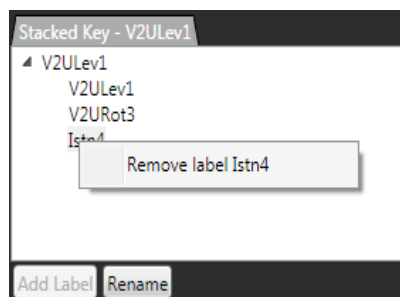

Figure 17-9 Remove Label from Stacked Key

- 1) Double click the Stacked Key on the mimic of the panel using the left mouse button. The Stacked Key window displays all labels on the stack.
- 2) Click the label to be removed.
- 3) Click the Remove Label context box to remove the label.

17.4 Panel programming preferences

To configure the panel programming preferences, select **Configuration > Preferences > Panel Operation**.

The screenshot shows the 'Panel Operation' tab in the configuration software. The interface is organized into several sections:

- V-Series Specific Settings**
 - V-Series Shift Page Settings**
 - Selectable Shift Page
 - Cyclic Shift Pages
 - Disable shift menu unless there is two or more shift pages configured
 - Delay Shift and Main menu activation time (by 3 seconds)
 - Supervisor Mode Settings**
 - Disable Supervisee Label Text Inversion
 - Disable Supervisor Label Text Inversion
 - Crosspoint Settings**
 - Set the V-Series minimum crosspoint level to -72dB
- I-Station Specific Settings**
 - I-Station Shift Page Settings**
 - Keypad Selectable Shift Page
 - Cyclic Shift Pages

Figure 17-10 Panel Operation Tab

V-Series specific settings

This option enables you to determine how the V-Series panel shift button operates:

- **Selectable Shift Page** – the shift button toggles between the Main page and the last selected shift page (short press) or displays a list of shift pages (long press).

- Cyclic Shift Pages – the shift button cycles through consecutive shift pages (short press) or displays a list of shift pages (long press)

There are also checkboxes to:

- Disable the shift menu unless two or more shift pages are configured.
- Delay the shift and main menu activation time to three seconds.
- Disable supervisor and supervisee label text inversion.

Crosspoint settings

By default, there is a default crosspoint level (-72dB) that can be set by a V-Series panel. This prevents panels from being able to completely mute audio. The tickbox allows the user to remove this limitation and achieve a full cut for crosspoint levels at the panel.

I-station specific settings

These settings enable you to determine whether I-station shift pages are selectable from the keypad or cyclic.

17.5 Key operation preferences

Tally Settings

Red ▼

Panels generate In Use Tallies on talk out AND receive

Panels continue to receive incoming calling tally AFTER reply

Set VOX/In Use LED tally on active keys only

Feedback Settings

Forced listen appears in reply key

Single Reply Key Mode Settings

New calls go to the BACK of the Reply Key Queue/Line

New calls go to the FRONT of the Reply Key Queue/Line

Key Customizations

Allow Third Party keys

Figure 17-11 Key Operation

Tally Settings

Use this section to change the incoming Tally light color (the default is red). The options are:

- Red. Tally light color is red
- Green. Tally light color is green.

There are three checkboxes:

- Panels generate In Use Tallies on talk out AND receive
- Panels continue to receive incoming calling tally AFTER reply
- Set VOX/In Use LED tally on active keys only

Feedback settings

If you select the **Forced listen appears in reply key** option, the label of any Forced Listen port appears in the Reply / Answerback stack of the listening panel. This can be over-ridden by each individual port's option to Prevent Reply Signalization.

The option is unchecked by default.

Single Reply key mode settings

Use this section to determine the order in which incoming calls to a panel are stacked on the Reply Key.

- If the **New calls go to the BACK of the Reply Key Queue/Line** option is selected then the calls are ordered on the basis of first in stays on top of the stack so the reply key answers the calls in the order they are received.
- If the **New calls go to the FRONT of the Reply Key Queue/Line** option is selected, then the calls are ordered on the basis of last in goes to the top of the stack. This means that the Reply Key answers stacked calls by starting with the most recent call.

The default is that the first call is answered first.

Key customizations

You can allow third-party keys.

17.6 Expansion panels

Host panels can support up to eight expansion panels.

To add an expansion panel

- 1) Select **Hardware > Cards and Ports** and select the port for the lever key panel.

- 2) Select **Panel Options > Expansion Panels**.
- 3) Click **+** to add an expansion panel.

Note: Click **X** to remove an expansion panel.

To display the expansion panel mimic, from the panel programming screen, open the drop-down list (normally displaying **Main Panel**) to show the list of all the expansion panels configured and select the required expansion panel.

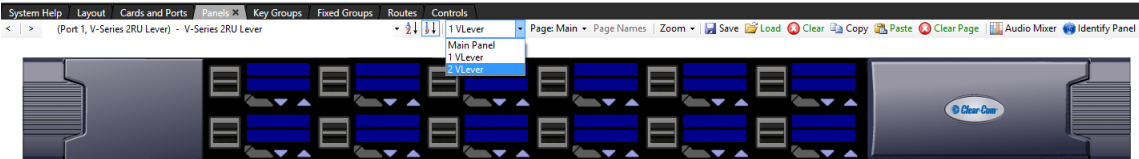

Figure 17-12 V-Series Lever Key Expansion Panel

Labels are assigned to keys in the same way as main panels and the option menu is available.

17.7 V-Series panel programming

This section covers the programming of the V-Series lever key, push button, and rotary panel types and their associated expansion panels.

17.7.1 V-Series lever key panels

To select a connected V-Series lever key panel:

- 1) From **Configuration > Panels**, select the required panel from the drop-down list or use the **< >** icons to step through the list of panels.

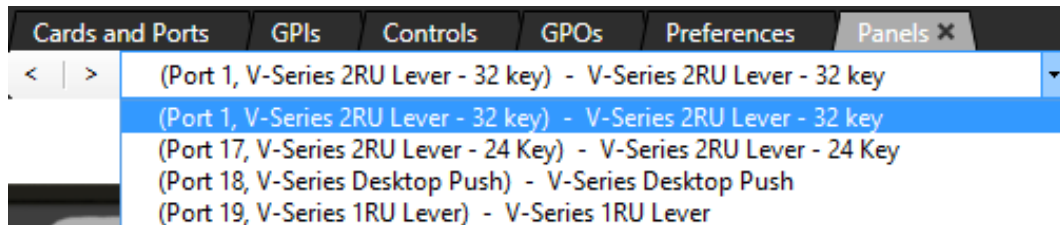

Figure 17-13 Scrollable list of panels

- 2) To assign keys, click on the required item in the list of available labels, and then drag the items to the required key and drop them over the display corresponding to the key. Click on the mouse to confirm the assignment.

Note: You can change the position of the Reply key by selecting REPLY in the Special Entities section, and dragging it to the required key. You can also move the key

by clicking and dragging it from its current location and dropping onto a new location.

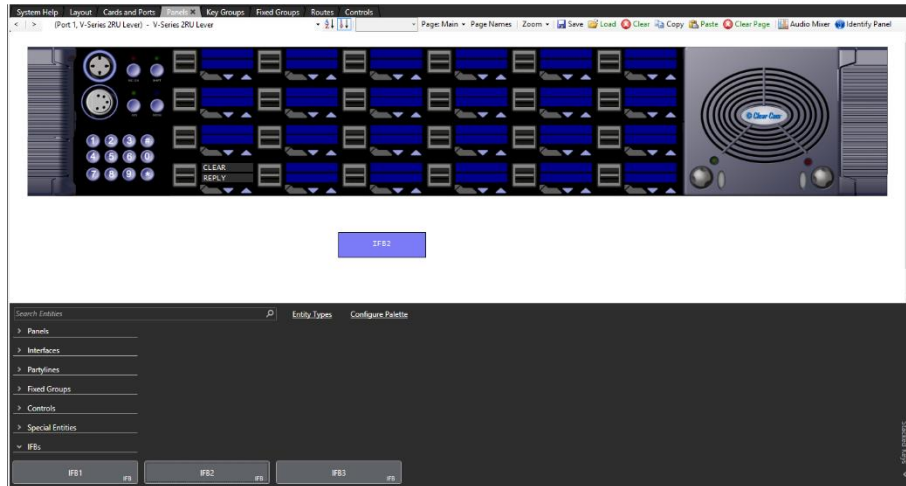

Figure 17-14 Assigning a Label on a Lever Key Panel

Each blue display window is divided into an upper and lower section with the upper section being the listen label and the lower section being the talk label. This corresponds to the lever key action to activate the talk or listen routes (up to listen, down to talk).

If the mouse pointer is positioned over a key display/label the details of the label are displayed.

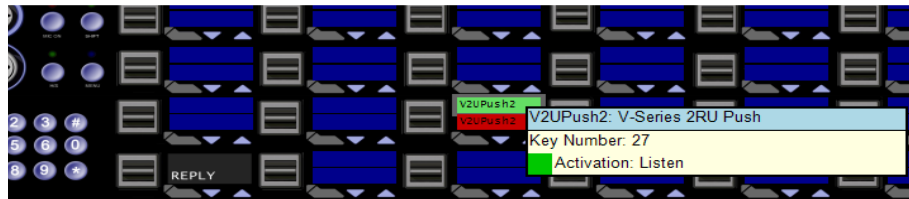

Figure 17-15 V-Series Lever Key Assignment

17.7.2 Action menus

To display the action menu for a key, position the pointer over the label and right-click the mouse. A list of options appears:

Activation

The activation option determines how the key behaves when activated. To set the key activation type:

Right click over the required key and then select **Activation** to display the activation options.

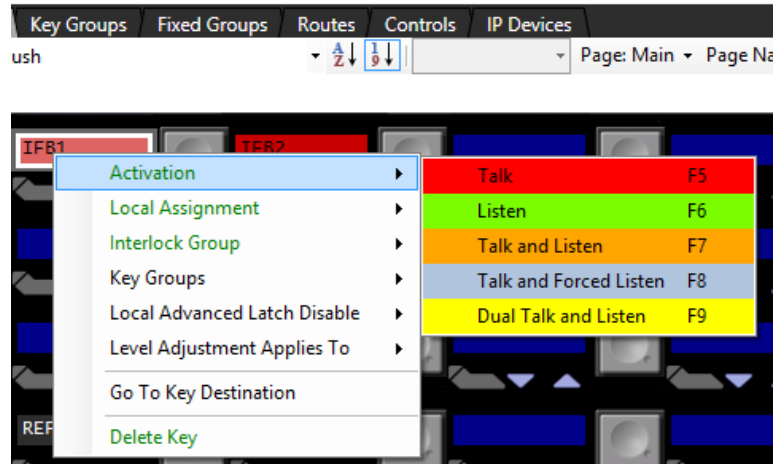

Figure 17-16 Key Activation

Destination Listen (IFB Return)

Note: This option is only available for IFB keys.

This option enables the operator to listen to the audio from the IFB return port or audio going to the IFB destination port. If there are multiple IFB destinations/returns, the audio routed to the listener is the sum of all the audio heard at the destination/returns ports.

If Destination Listen is on, the operator can listen to the IFB destination audio

If Destination Listen is off, the operator can listen to the IFB return audio.

Right click over the required key and then select **Destination Listen > On/Off**.

Local assignment

This option enables local key assignment to overwrite the selected key or not. This allows you to limit the keys a panel operator can overwrite when locally assigning keys by Fast Key Assign (V-Series only) or by Local Key Assignment (on panels supporting this facility).

Right click over the required key and then select **Local Assignment > Allow Local Assignment/Disallow Local Assignment**.

Interlock group

This option assigns several keys on a panel into an interlock group and restricts the group so that only one key of the group can be activated at any one time. This function only refers to talk paths.

For example, if a panel had five keys programmed to talk to cameras 1 to 5 then by setting these into an interlocked group only one camera key can be selected at a time.

You can assign panel keys to a maximum of nine interlocked groups.

Note: The interlock groups are specific to the panel they are programmed for and do not affect interlock groups that may be set up on any other panel in the system.

To add a key to an interlocked group:

- 1) From **Panel Programming**, select the desired panel.
- 2) Right click on the desired key to display the key options list.
- 3) Select the **Interlock Group** entry to display the interlock group options list.
- 4) Select the required interlock group or **None** if the key is not to be in any interlock group.

The key may be added to other interlock groups as required.

- 5) The key interlock groups are displayed in the key information popup.

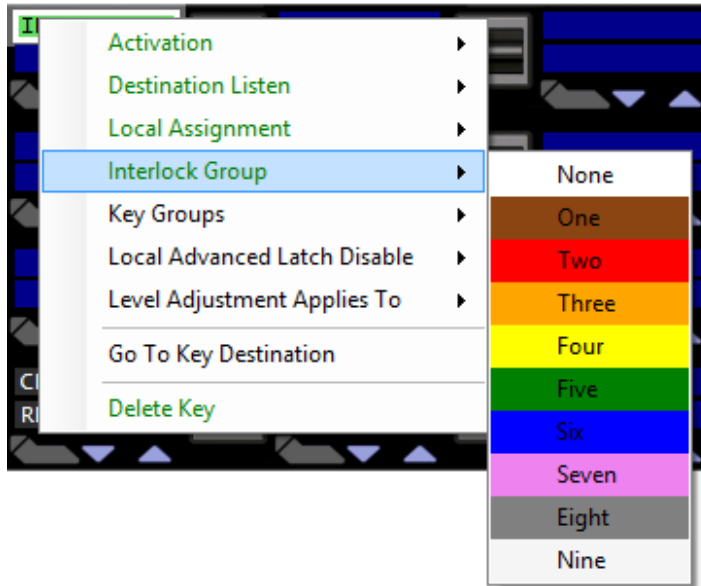

Figure 17-17 Interlock Group Assignment

Key Groups

If key groups have been assigned in **Configuration > Key Groups**, you can assign a key to one of the configured key groups. See section **18.7 Key groups**.

Key groups also can be assigned as though they are normal keys.

Local advanced latch disable

When the mouse pointer is over this entry a second menu is displayed giving the options to set Local Advanced Latch Disable to On or Off. Select and click on the required option. This performs the same function as **Latch Disable** in the Local Advanced facility. It allows or disallows a panel to latch a key to another device.

Level Adjustment Applies To

You can select whether the level adjustment applies to:

- Crosspoint control
- Input (Global) level control
- Output (Global) level control

Go to key destination

Click the **Go To Key Destination** entry to display the editor screen for the type of destination the key refers to. For example if the destination is a panel then the panel is displayed on the **Panels** screen. For a partyline key, the **Partylines** editor screen is displayed with the partyline highlighted.

Delete key

Click the **Delete Key** entry in the menu to delete the assigned label (shown highlighted).

Note: Only the highlighted label is deleted. The green listen label for that key is not deleted.

17.7.3 V-series pushbutton panels

- 1) Select **Panels** from the **Configuration** menu to display the panel options toolbar and select the panel from the drop-down list or use the < > icons to step through the list of panels.

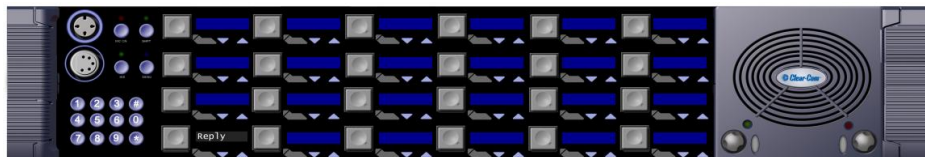

Figure 17-18 V-Series Pushbutton Panel

- 2) To assign keys drag items from the list of available sources and destinations to the required key and drop them over the display corresponding to the key.

Note: You can change the position of the Reply key by selecting REPLY in the Special Entities section, and dragging it to the required key. You can

also move the key by clicking and dragging it from its current location and dropping onto a new location.

Entities in the label palette appear differently for push button panels - they are split into left and right sections for talk and listen respectively.

- 3) Click on the talk section for a talk key. Click on the listen section for a listen key

Unlike the lever key panels, only one label can be assigned to a key rather than two, but key activation can be assigned unlike lever key panels.

- 4) Position the mouse pointer over a key display/label to display the details of the label.



Figure 17-19 V-Series Pushbutton Assignment

- 5) To display the action menu for a key, position the pointer over the label and right-click the mouse.

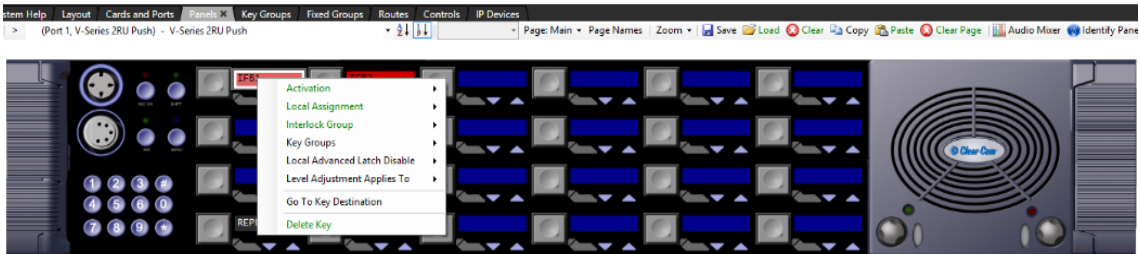

Figure 17-20 Pushbutton Properties Menu

Action menus

See section **17.7.2 Action menus**.

17.7.4 V-series rotary panels

- 1) Select **Panels** from the Configuration menu to display the panel options toolbar and select the panel from the drop-down list or use the < > icons to step through the list of panels.

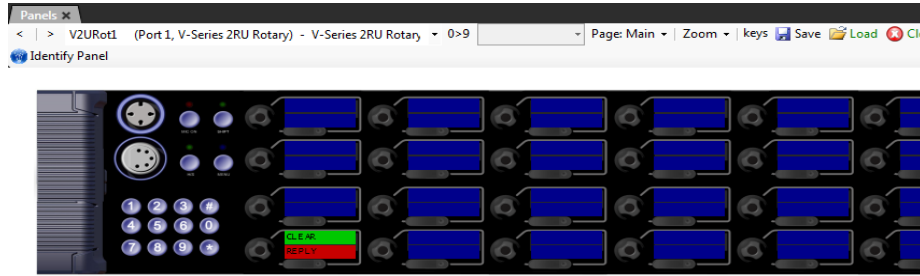

Figure 17-21 V-Series Rotary Key Panel

- 2) To assign keys, click on the required item in the list of available talk and listen labels, and then drag the items to the required key and drop them over the display corresponding to the key. Right click on the mouse to confirm the assignment.

Note: You can change the position of the Reply key by selecting REPLY in the Special Entities section, and dragging it to the required key. You can also move the key by clicking and dragging it from its current location and dropping onto a new location.

On rotary panels Listen and Talk are actioned by separate controls (rotary knob for Listen, talk button for Talk) so different paths can be assigned for Talk and Listen on the same key.

It is also possible to assign other keys to the Reply key on V-Series panels.

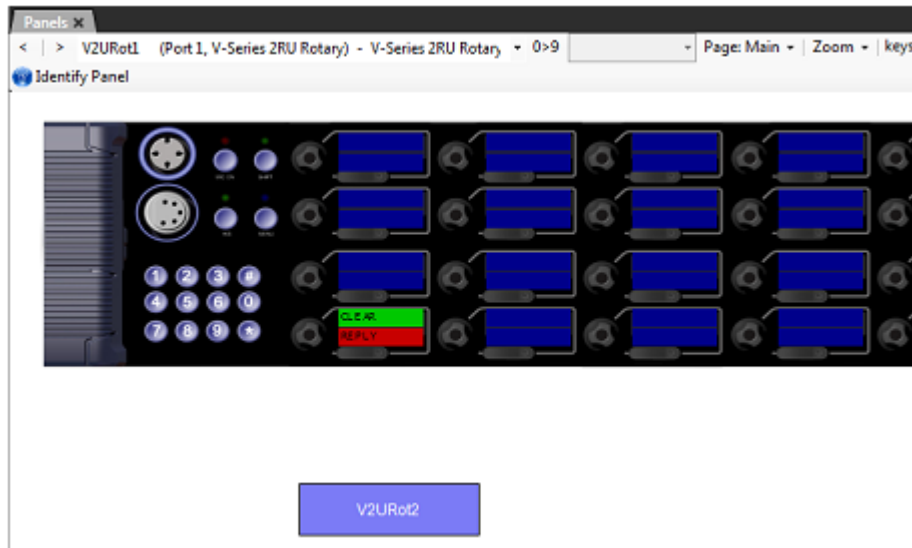

Figure 17-22 Assigning a Label on a Rotary Control Panel

Each blue display window is divided into an upper and lower section with the upper section being the listen label and the lower section being the talk label. This

corresponds to the rotary push action to activate the listen route and the talk button below the display to activate the talk route.

- 3) Position the mouse pointer over a key display/label to display the details of the label.

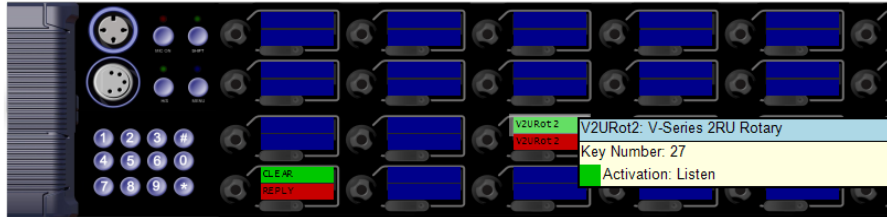

Figure 17-23 V-Series Rotary Key Assignment

- 4) To display the action menu for a key, position the pointer over the label and right-click the mouse.

Note: For information on scrolling assignment setup, see section **18.4.3 Scrolling assignment** and the V-Series User Guide.

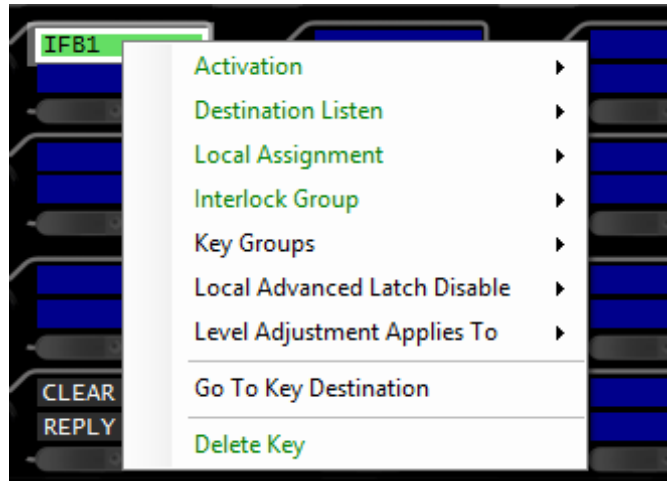

Figure 17-24 Rotary Key Properties Menu

Action menus

See section **17.7.2 Action menus**.

17.8 Concert panel programming

A Concert panel is a virtual panel (or soft panel) that runs on a PC and provides the same functionality as a normal hardware panel such as a V-Series panel. Concert panels can connect to an Eclipse matrix via a Concert server.

Concert panel keys act as pushbuttons rather than lever keys and are operated using a mouse or other pointing device. Concert panels do not support any expansion panels. The following section covers the programming of Concert panels.

- 1) Select **Panels** from the Configuration menu to display the panel options toolbar and select the panel from the drop-down list or the < > icons to step through the list of panels.

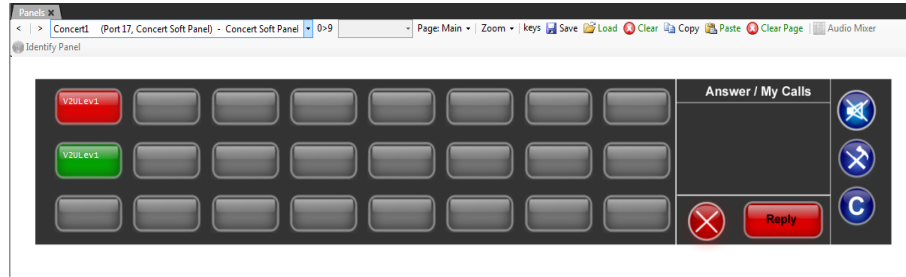

Figure 17-25 Concert Panel

- 2) To assign keys, drag items from the list of available sources and destinations to the required key and drop them over the display corresponding to the required key.
As with V-Series pushbutton panels only one label can be assigned to a key and key activation can be assigned.
- 3) Position the mouse pointer over a key display/label to display the details of the label.

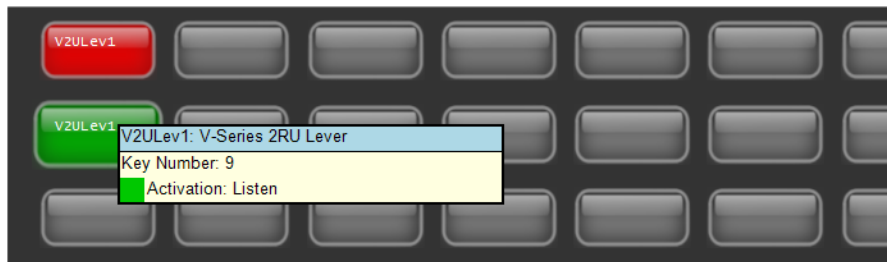

Figure 17-26 Concert Panel Assignment

- 4) Position the mouse pointer over the label and right-click the mouse to display the action menu for a key.



Figure 17-27 Concert Panel Properties Menu

17.8.1 Action menus

See section **17.7.2 Action menus**.

17.9 i-Series programming

This section deals with programming i-Series main panels and expansions panels.

Note: I-series panels only display five characters per key.

17.9.1 Assigning labels

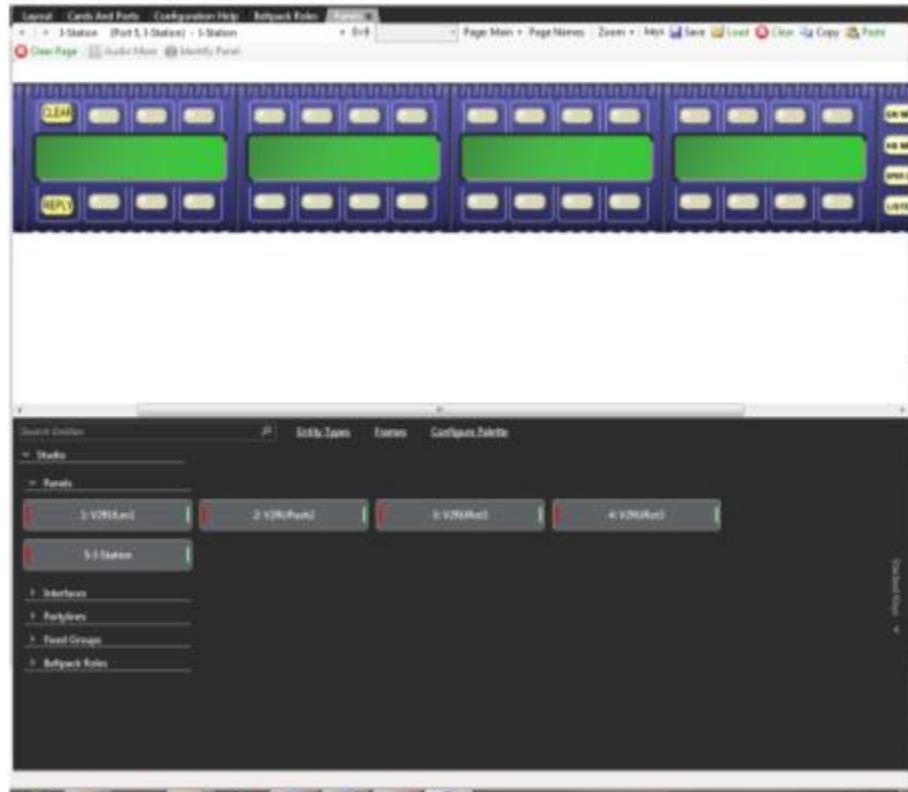

Figure 17-28 Label Assign Screen

To assign a label to a given selector

- 1) Locate the mimic of the panel to programme by either using the scroll arrows or the drop-down list box from the middle area of the screen.
- 2) Keys are assigned in the normal way by clicking on the required item in the list of available labels, and then dragging the item to the required key and dropping them over the display corresponding to the key and clicking on the mouse to confirm the assignment.
- 3) Drag the mouse cursor up the screen into the mimic area and position it over the required key.
- 4) Repeat for all required Label programming.

- 5) To program a Talk and Listen key, press and hold the keyboard Ctrl key and then select the Talk label and place that onto the panel.
- 6) To program a Talk and Forced Listen key press and hold the keyboard Alt key and then select the Talk label and place the label onto the panel.

17.9.2 Re-assignment of labels

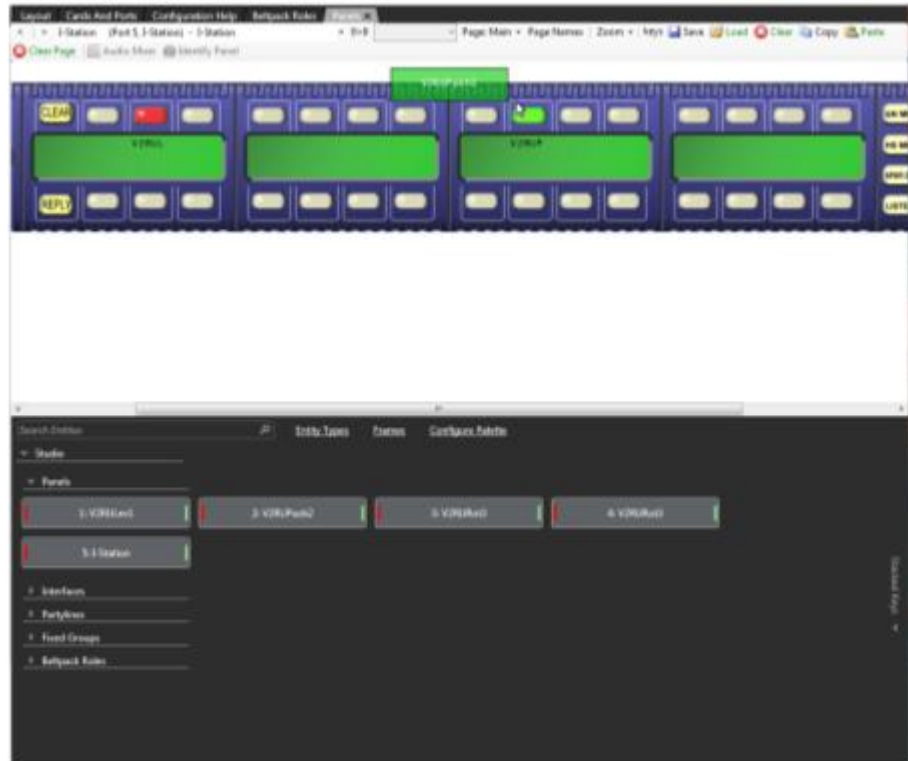

Figure 17-29 Reassign Labels Screen

To re-assign a label

- 1) Select the required port and locate the label that is required to be re-assigned.
- 2) To select the new Label, place the mouse cursor over the label.
- 3) Left click and hold down the mouse button.
- 4) Whilst holding down the mouse button drag slightly down the mouse until the label is free from the display.
- 5) Position the Label over the new position and release the mouse button to drop the label into the new position.

17.9.3 Action menus

See section **17.7.2 Action menus**.

17.9.4 i-series advanced functions

The i-Series operates in one of four modes:

- **COM mode** is the default mode. In this mode, the i-Series panel operates as a simple panel. Talk labels are assigned to destinations, and listen labels are assigned to sources.
- **IFB mode** allows the i-Series to assign a program audio source or sources to an IFB Global destination. For example, on-the-air audio can be assigned to the talent or announcer in a television studio application. It is called IFB mode because the program audio source that is routed to the IFB destination can be interrupted by an incoming intercom call to the IFB destination.
- **PL mode** allows the panel operator to add and delete members of a partyline directly from the panel.
- **FG mode** allows the panel operator to add and remove members of a fixed group directly from the panel.

For more details of how to use the i-Series advanced functions, see the ***i-Series Panels User Guide***.

17.9.5 Using EHX to set up i-Series fixed group membership options

A fixed group occurs when one source needs to call many destinations at one time. The panel operator can add and remove members of a fixed group in real time with the i-Series, provided that the feature has been enabled in EHX.

To enable the feature in EHX

- 1) Open the required map configuration in EHX.
- 2) From **Cards and Ports** screen, select the required panel.
- 3) Select **Port Properties > AP Panel Options > Fixed Group Assignment**. Click the drop-down box to turn the feature on or off.
 - When the check box reads true the feature is on.
 - When the check box reads false the feature is off.
- 4) From Panel Programming, select the panel to which the i-Series is connected, and immediately below it, select the i-Series panel.
- 5) Assign the fixed group source as a talk key on the i-Series panel on screen.

- 6) Assign potential fixed group members as listen keys on the i-Series panel on the screen.
- 7) From the Eclipse HX Downloads menu, click Apply and Reset.

EHX uploads the information to the i-Series panel.

17.9.6 Using EHX to Set up i-Series IFB options

After a program audio source has been attached to a matrix port, the EHX operator can assign the audio source to an IFB destination with the i-Series Assignment Panel in panel programming.

To assign an audio source to an IFB destination

- 1) In **Cards and Ports** select the i-Series panel.
Highlight the entire row when selecting the panel.
- 2) Go to **Port Properties > AP Panel Options > IFB assignment**. Select True (the box is checked).
- 3) From **Panel Programming**, select the i-Series panel.
- 4) Assign the IFB destination as a talk label.
- 5) Assign the IFB source or sources as a listen label.
- 6) Click Apply Label Changes from the Eclipse HX Download menu to send information to the matrix.

17.9.7 Using EHX to set up i-Series partyline membership options

The panel operator can add and remove members of a partyline in real time with the i-Series provided this feature has been enabled in EHX.

To enable the feature in EHX:

- 1) Open the required map configuration in EHX.
- 2) From the **Cards and Ports** screen, select the desired panel.
The Advanced Settings screen opens.
- 3) From Port Properties, select Partyline Assignment from i-Series AP Panel Options. Click the drop-down box to turn the feature on or off.
 - When the check box reads true the feature is on.
 - When the check box reads false the feature is off.

- 4) From Panel Programming select the i-Series panel.
- 5) Assign the partyline as a talk key on the on screen i-Series panel.
- 6) Assign potential partyline members as listen keys on the on screen i-Series panel.
- 7) From the Eclipse Downloads menu, click Apply and Reset.

EHX uploads the information to the i-Series panel.

17.9.8 i-Series panel options

This functionality is limited to the current configuration and **label sets** cannot be transferred between configurations. The options for panel Save, Load, Copy, Paste, Upload and Clear are provided on the panel configuration toolbar above the panel mimic.

Page

- 1) Select **Page** to display a list of pages for the panel as a drop-down list. Click the required page to update the mimic to the page.

Save

- 1) Select **Save** on the Panel Programming toolbar to display the label file save dialog.
- 2) Enter the name of the file which will default to the `.ccl` extension. The keys from all pages are saved (including shift pages where supported) but the keys from any expansion panels that may be fitted are not saved in the file.

Expansion panel labels must be saved separately.

Load

- 1) Select **Load** on the Panel Programming toolbar to display the dialog for selecting and opening a panel label (`.ccl`) file.
- 2) Select the required file and click **Open** to load the labels from the file. When a label load is performed all the labels on a panel (including shift pages) and cleared before the new labels are applied.

If the type of panel being loaded is not the same as the type of panel the label file was saved from this may result in labels being lost when the panel is loaded.

Copy

- 1) Select **Copy** on the Panel Programming toolbar to copy the labels of the current panel page only into the scratch pad. You cannot copy labels from expansion panels.

Paste

- 1) Select **Paste** on the Panel Programming toolbar to paste the labels copied to the scratch pad onto the currently selected panel. All the labels currently on the page are lost. This allows single pages of labels to be pasted on to the panel.

If the type of panel being pasted to is not the same as the type of panel the labels were copied from this may result in labels being lost when the labels are pasted onto the new panel.

Clear

- 1) Select **Clear** on the Panel Programming toolbar to clear all the labels from the current panel including shift pages but excluding any attached expansion panels.

17.9.9 Fast key assign restrictions (i-series)

The i-Series Advanced Settings area, located on the rightmost side of **Cards and Ports** offers three Soft Menu Restrictions:

- Dial Phone Mode Access
- Information Mode Access
- Key Assign Mode Access

By default, the panel operator has access to these options from an i-Series, but if the check box for any of these options is cleared, the panel operator cannot access the menus from the i-Series front panel.

17.10 Setting up assignment panel partyline membership options

The panel operator can add and remove members of a partyline in real time from an assignment panel provided this feature has been enabled for the panel in EHX.

To enable this feature in EHX

- 1) Open the required map configuration in EHX.

- 2) From the **Cards and Ports** screen, select the desired panel.
- 3) From Port Properties, select Partyline Assignment from AP Panel Options. Click the drop-down box to turn the feature on or off.
- 4) When the check box reads true the feature is on.
- 5) When the check box reads false the feature is off.
- 6) From **Panels** in the Configuration menu select the required panel or the panel to which the AP (Assignment Panel) mode is enabled.

Note: On the panel, the key will show the particular AP mode that is selected or the panel, for example **INTERCOM, IFB Assign, PL Assign or FG Assign**.

- 7) Assign the partyline as a talk key on the on panel.
- 8) Assign potential partyline members as listen keys on the on screen panel.
- 9) From the Eclipse HX Downloads menu, click **Apply and Reset**.

EHX uploads the information to the panel.

For more information, see the i-Series User Guide.

17.11 Setting up assignment panel fixed group membership options

A fixed group occurs when one source needs to call many destinations at one time. Members of a fixed group may be added or removed by the panel operator in real time with the assignment panel provided this feature is enabled for the panel in EHX. To enable the feature in EHX

- 1) Open the required map configuration in EHX.
- 2) From the **Cards and ports** screen, select the required panel.
- 3) From Port Properties, select Fixed Group Assignment from AP Panel Options. Click the drop-down box to turn the feature on or off.
- 4) When the check box reads true the feature is on.
- 5) When the check box reads false the feature is off.

- 6) From **Panels** in the Configuration menu select the required panel or the panel to which the AP (Assignment Panel) mode is enabled.

Note: On the panel, the key will show the particular AP mode that is selected or the panel, for example **INTERCOM**, **IFB Assign**, **PL Assign** or **FG Assign**.

- 7) Assign the fixed group source as a talk key on the assignment panel on screen.
- 8) Assign potential fixed group members as listen keys on the assignment panel on the screen.
- 9) From the Eclipse HX Downloads menu, click Apply and Reset.

EHX uploads the information to the assignment panel.

17.11.1 Keep hidden keys active (i-series panels)

- 1) In Advanced Settings for i-Series panels, select the Keep Hidden Keys Active option. When this option is selected, audio paths from an i-Series panel's main page are maintained even when the panel operator switches to the shift (swap) page.
- 2) Clear the check box to turn off this option. If this option is disabled the audio paths from the main page are cut when the panel operator switches to the swap page.

This option is not selected by default.

17.12 Agent-IC Mobile Client

To find out how many Agent-IC clients are licensed on a matrix, do the following:

- 1) Select **Diagnostics > Event Log**.
- 2) In the right-hand pane, select  nd then select Request Info.
- 3) From the **Request Matrix Information** screen, select **Matrix Overview**.
The Agent-IC licenses are listed.

The following section covers the programming of the Mobile Client panel.

- 1) Select **Panels** from the **Configuration** menu to display the panel options toolbar and select the Mobile Client from the drop-down list or the > icons to step through the list of panels.

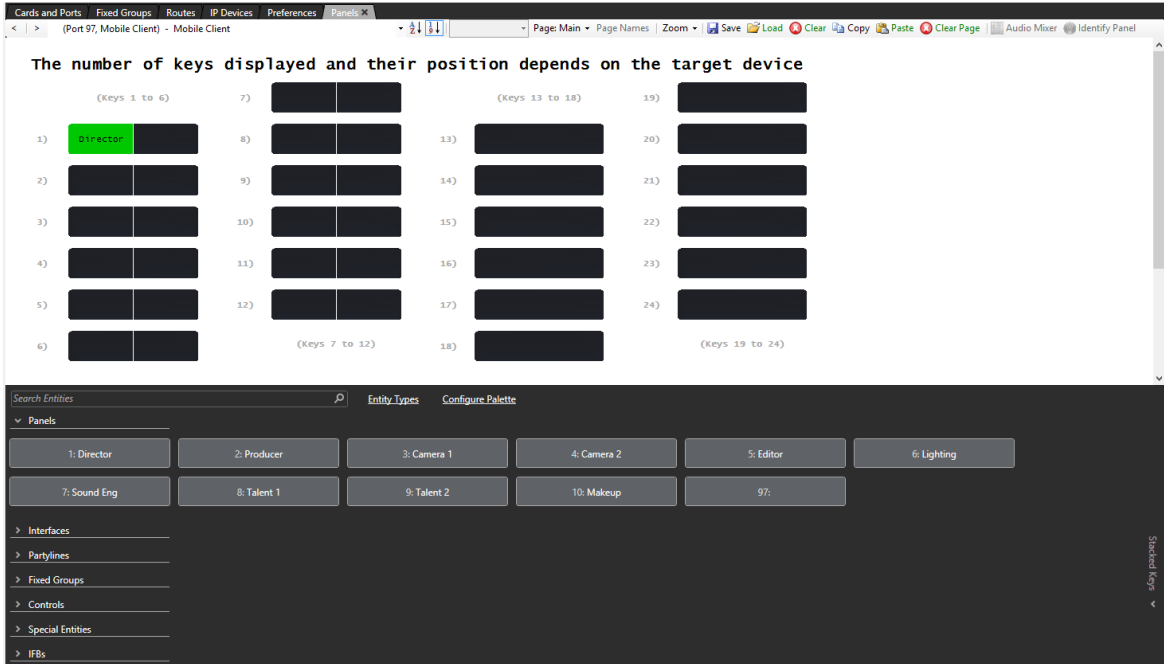

Figure 17-30 Mobile Client Panel

Note: The number of keys displayed on the Mobile Client screen depends on the target device that the Mobile Client is installed on.

- 2) To assign keys, click on the required item in the list of available labels, and then drag the items to the required key and drop them over the display corresponding to the key. Click on the mouse to confirm the assignment.
- 3) To display the action menu for a key, position the pointer over the label and right-click the mouse.

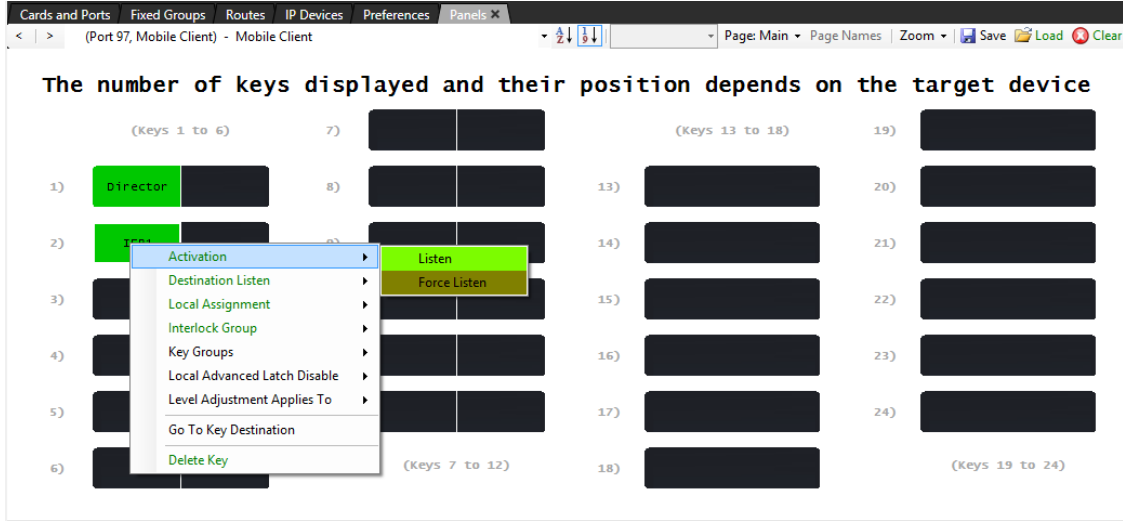

Figure 17-31 Key Properties Menu

Destination listen

Note: This option is only available for IFB keys.

This option enables the listen key to feed all the audio that is routed to the IFB to the panel user. If there are multiple IFB destinations, the audio routed to the listener is the sum of all the audio heard at the destination ports.

Local assignment

- 1) Click the **Local Assignment** entry to display the available options for local key assignment. The options are to allow local key assignment to overwrite the selected key or to disallow local key assignment to overwrite the selected key. This allows you to limit the keys a panel operator can overwrite when locally assigning keys by Fast Key Assign (V-Series only) or by Local Key Assignment (on panels supporting this facility).

Interlock group

You can assign several keys on a panel into an interlock group and restrict the group so that only one key of the group can be activated at any one time. This function only refers to talk paths.

For example, if a panel had five keys programmed to talk to cameras 1 to 5 then by setting these into an interlocked group only one camera key can be selected at a time.

There are nine available interlocked groups to which the EHX user can assign any or all panel keys.

The interlock groups are specific to the panel they are programmed for and do not affect interlock groups that may be set up on any other panel in the system.

To add a key to an interlocked group:

- 1) From **Panel Programming**, select the desired panel.
- 2) Right click on the desired key to display the key options list.
- 3) Select the **Interlock Group** entry to display the interlock group options list.
- 4) Select the required interlock group or **None** if the key is not to be in any interlock group.
- 5) The key may be added to other interlock groups as required.
- 6) The key interlock groups are displayed in the key information popup.

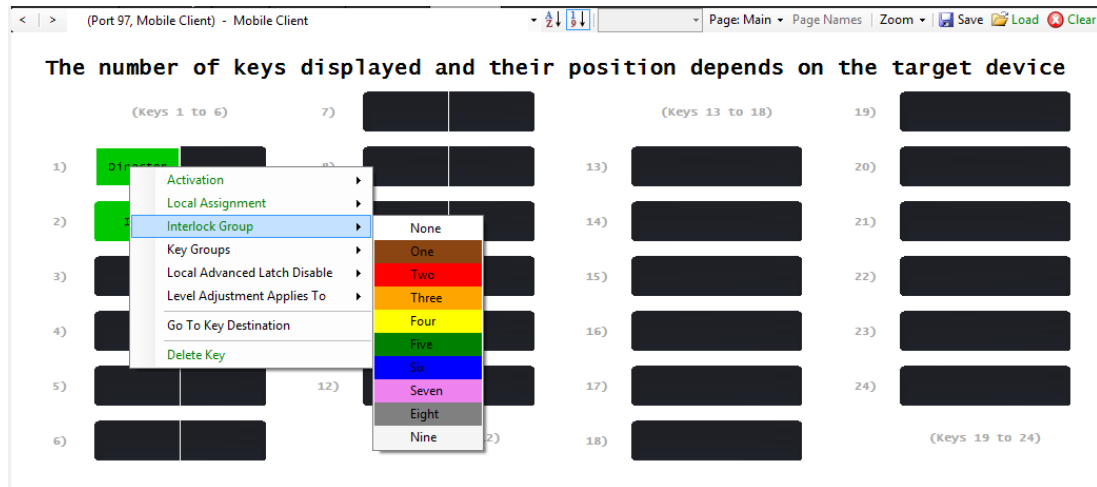

Figure 17-32 Interlock Group Assignment

Local advanced latch disable

When the mouse pointer is over this entry a second menu is displayed giving the options to set Local Advanced Latch Disable to On or Off. Select and click on the required option. This performs the same function as **Latch Disable** in the Local Advanced facility. It allows or disallows a panel to latch a key to another device.

Go to key destination

Click the **Go To Key Destination** entry to display the editor screen for the type of destination the key refers to. For example, if the destination is a panel then the panel is displayed on the **Panels** screen. For a partyline key the **Partylines** editor is displayed with the partyline highlighted.

Delete key

Click the **Delete Key** entry in the menu to delete the assigned label (shown highlighted).

Note: Only the highlighted label is deleted. The green listen label for that key is not deleted.

17.13 ICS-1008 and ICS-1016 panels

Note: The illustrations in this section show an ICS-1008 panel. The procedure is identical for an ICS-1016 panel.

- 1) Select **Panels** from the **Configuration** menu to display the panel options toolbar and select the panel from the drop-down list or use the > icons to step through the list of panels.

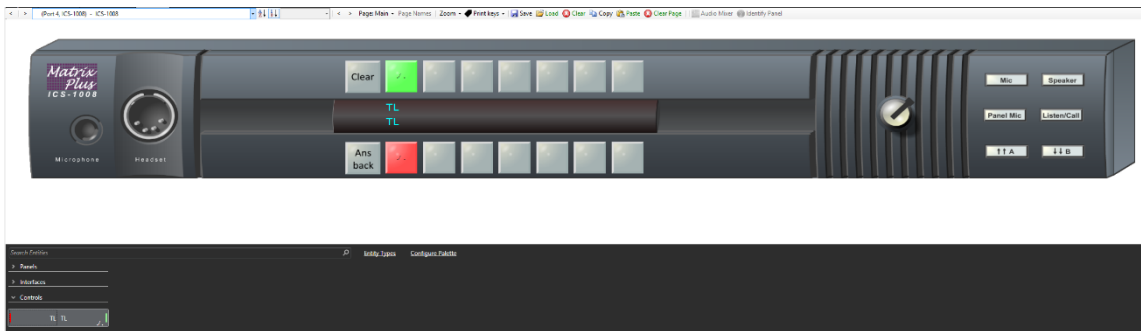

Figure 17-33 ICS-1008 Panel

- 2) To assign keys drag items from the list of available sources and destinations to the required key and drop them over the display corresponding to the key.
- 3) Position the mouse pointer over a key display/label to display the details of the label.



Figure 17-34 ICS-1008 Key Assignment

- 4) To display the action menu for a key, position the pointer over the label and right-click the mouse.

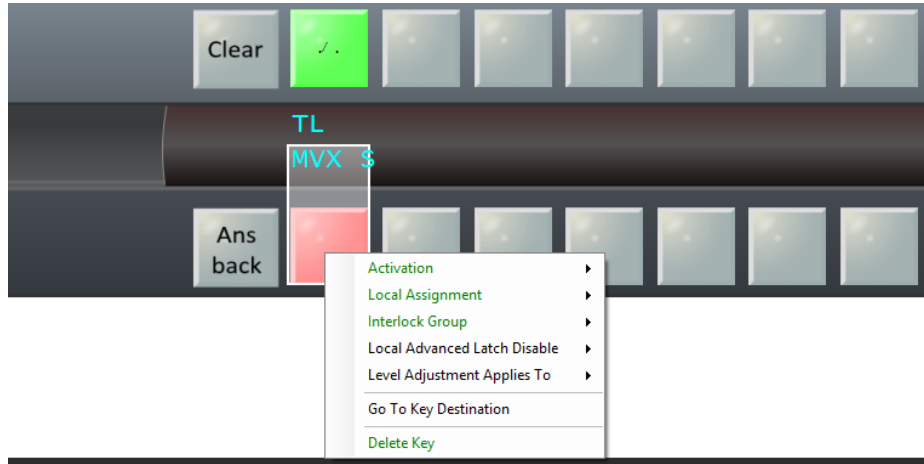

Figure 17-35 ICS-1008 Action Menu

17.13.1 Action menus

See section 17.7.2 Action menus.

17.13.2 Printing key labels

You can print the names of the keys assigned on the panels, and attach the printout to the panel. You can select and print key labels for one panel, or print key labels for more than one panel.

- 1) Select **Print keys**.

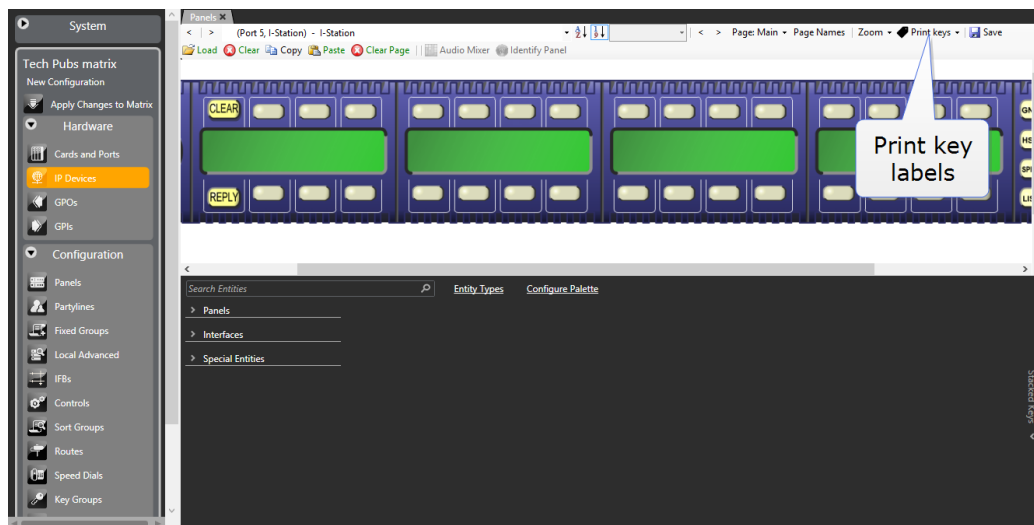

Figure 17-36 Print key labels

- 1) Select one of:
 - Print as BMP – creates a `.bmp` file for the displayed panel.
 - Print as CSV – creates a `.csv` file (Comma Separated Variables) for the displayed panel.
 - Print all as BMP – creates a `.bmp` file for all connected ICS and i-Series panels.
 - Print all as CSV – creates a `.csv` file for all connected ICS and i-Series panels.
- 2) Save the file to the required location.
- 3) Open the file in graphics software (or in the case of `.csv` files, in a text editor) and edit as necessary before printing.

Note: To ensure correct spacing, do not scale the file either in the graphics software or on printing.

17.14 ICS-22 panels

To use an ICS-22 panel, it is configured as an ICS-1008 panel. See **17.13 ICS-1008 and ICS-1016 panels**.

Any Talk keys **MUST** be placed in the lower row to ensure that they control Talk routes, and that the panel Talk/Listen switch controls the Listen routes.

Figure 16-37 shows a key labeled as S5-NO configured on channel A, and a key labeled as T-Pan configured on channel B.



17-37 ICS-22 panel configuration

Figure

17.15 Local advanced

The Local Advanced screen sets functions that determine how every panel and interface in the system interacts with each other at the device level. For example, IFB levels can be set for every individual device or Forced Listen can be enabled or disabled between any two specific system devices. To open the Local Advanced Screen:

- 1) Select the **Local Advanced** entry in the Configuration menu.

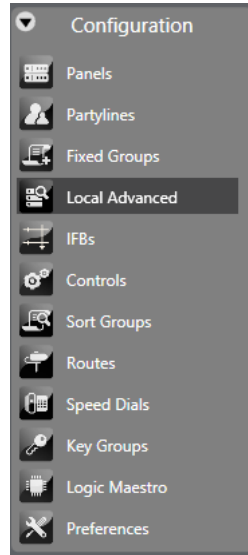

Figure 17-38 Local Advanced

The configured devices are displayed to form a grid with each square displaying the attributes set for interactions between the devices as a colored dot or empty if the attributes are not set. Tabs on the toolbar allow the specific attributes to be selected. Positioning the mouse pointer over a square displays a tooltip indicating the current status.

A key to the meaning of the colored dots that indicate status is shown in the top left hand corner of the Local Advanced screen. The Sources are listed down the left-hand side and the Destinations are listed across the top.

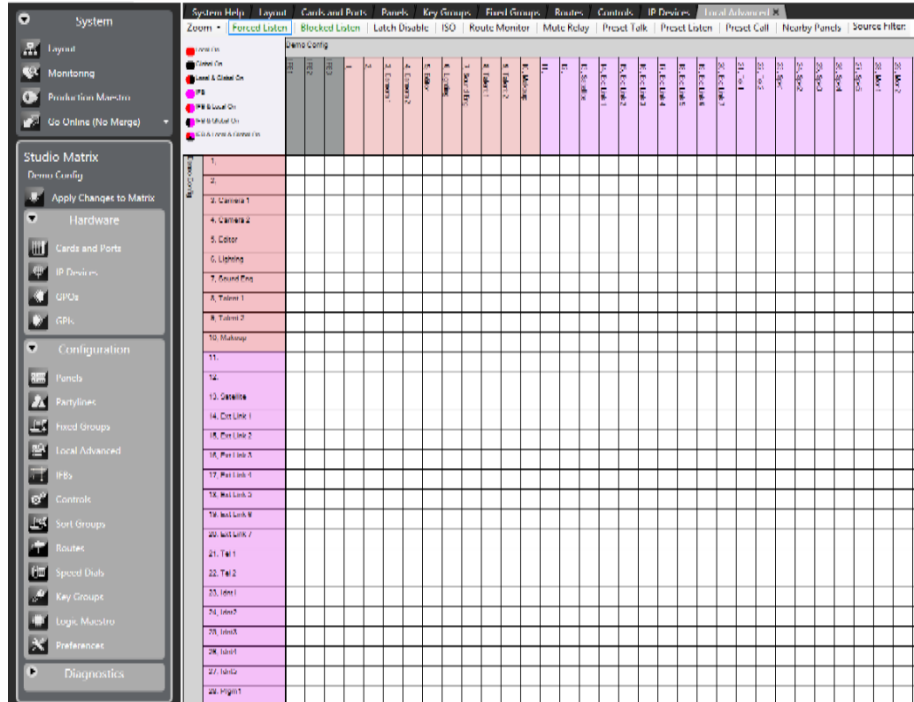

Figure 17-39 Local Advanced Functions

The type of source/destination is denoted by the color of the entry. These are:

- Grey - IFB
- Pink - Panel
- Yellow - Partyline
- Purple - Interface (Direct, FOR-22, Telephone, TEL-14, CCI-22)
- Blue - Fixed Group
- Green - Control

Note: IFBs are displayed on the **Forced Listen** tab.

The tabs allow the grid to be displayed for the various properties of the connections (such as Forced Listen, Latch Disable and so on).

- 2) Select one of the tabs to display a grid with sources and destinations which may have this property and the status of any connection between them. For example, selecting the **Blocked Listen** tab only displays panels and interfaces to which this property can apply. Where the property is enabled a colored dot is displayed in the square: red for local property assignment, black for global property assignment.

You can filter the items along the top by name using the text filter boxes on the right-hand side of the EHX Control Bar. There is a separate Source and Destination filter box.

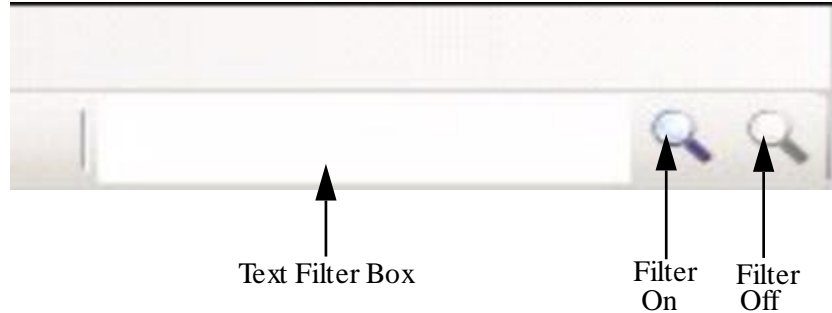

Figure 17-40 Source Filter

- 3) Enter the text to filter by and click on the filter icon to the right of the filter box left filter icon). Only the destinations with names containing the filter text are displayed on the top row. The sources are not filtered. To turn off filtering click on the rightmost of the two filter icons.

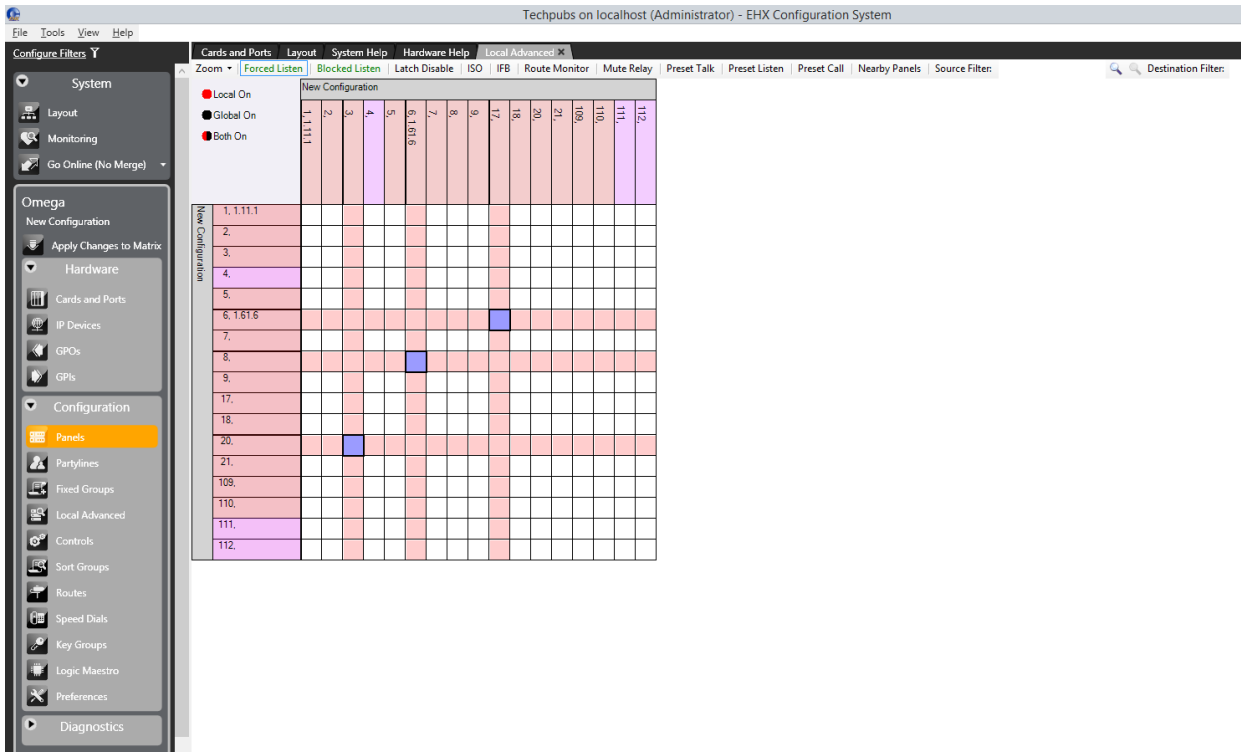

Figure 17-41 Multiple Tab Select Display

- 4) By holding down the Control key whilst selecting the tabs, you can select multiple tabs. In this case any squares representing connections are colored red if any of the select properties are set.

Note: Only local settings are displayed when multiple tabs are selected. Global settings are not shown.

When the mouse pointer is positioned over one of the squares of the grid a tooltip gives details of the connection.

Note: By not touching the mouse the tooltip remains on the screen.

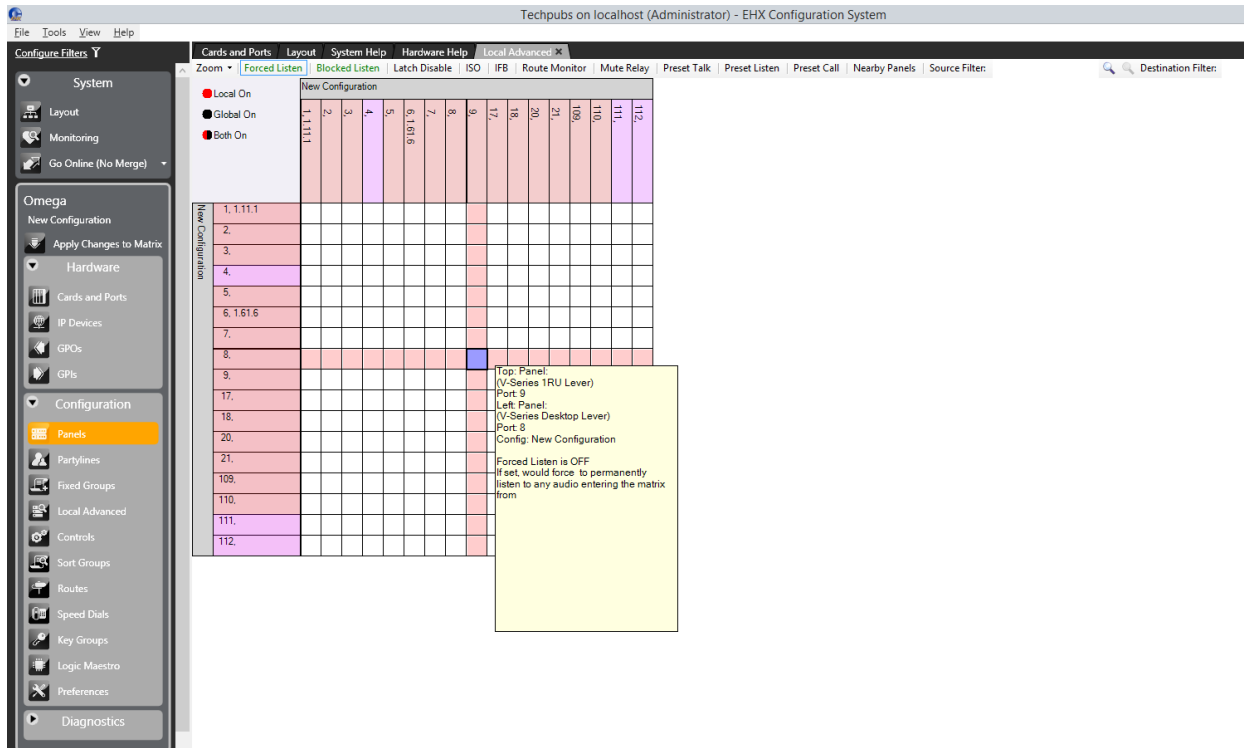

Figure 17-42 Local Advanced Information Display

- 1) Place the pointer over the square that intersects the required source and destination.
The tooltip displays the current properties.
- 2) Click the square. The square turns blue and the source and destination label backgrounds changes to white.
- 3) To set or clear the current property (for example, Latch Disable) right-click the mouse to display the On/Off options.
- 4) Use the pointer to select the required state and right-click or left-click on it to select it.
A red dot is displayed in the square if the function has been enabled in local mode.

Note: By holding down the Control key when assigning connection properties it is possible to move from square to square and make multiple selections with a single mouse click. If the Shift key is held down a block of connections can be assigned by clicking on limits of the required block selecting all the points between the limits. This allows large numbers of connections to be set very quickly.

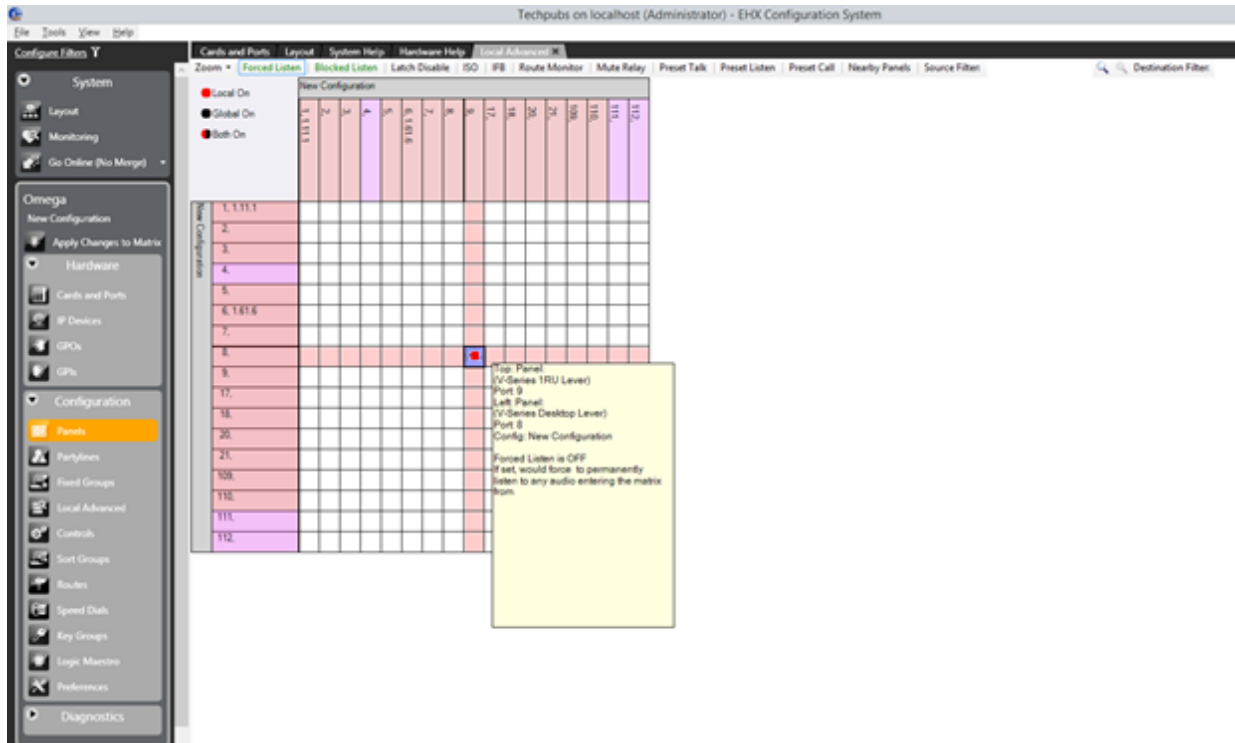

Figure 17-43 Local Advanced with a Property Selected

The following is a description of each option. Every option does not appear for every combination of source and destination.

The possible options are described below.

17.15.1 Forced listen

A forced listen is a permanently enabled audio path between a source and a destination that can only be interrupted by ISO calls. It does not have any association with a selector key.

On the forced listen tab, if the destination is an IFB the source is assigned as an IFB source to the IFB rather than creating a forced listen. A violet dot signifies this, and corresponding dots are shown for any IFB destinations that are assigned to the IFB.

Note: This is not an online function. An **Apply Changes** is required to push these changes to the Matrix.

If panel eavesdropping is disabled for a panel, the forced listen is not effective until the panel has at least one talk path set. Panel eavesdropping is enabled from the Advanced Settings screen of **Cards and Ports** for the source port. Forced listen audio is routed from the label on the left to the label on the top.

17.15.2 Blocked listen

If a listen is blocked between two ports, then an audio path from the source to that destination cannot be set under any circumstances. This is primarily used as a safety feature. For example, to prevent one studio's program feed from being accidentally routed to a destination in another studio.

17.15.3 Local latch disable

This function prevents talks to any label from latching. If a latch-disabled (PTT) label is assigned to a selector key, the operator physically holds down the key to activate the route PTT. A latch-disabled port's label can be included in a fixed group or partyline without automatically latch disabling the entire fixed group or partyline.

17.15.4 Local ISO

This function enables a panel or interface as a local ISO destination of the source panel or interface. When the source activates a talk to any of its local ISO destinations, that talk is a private, two-way path. All other talk paths from the source are interrupted. All existing talk and listen paths between the source and the destination are interrupted, except for other ISO talk paths. When the source terminates the talk, the destination's audio paths resume; when all ISO paths to the destination are deactivated, the destination's audio paths return to their previous states. If more than one panel activates an ISO path to the destination, both sources can talk and listen to the destination. For ISO talks to also interrupt listens at the source, check the ISO Interrupts All Other Listens box in the Matrix Configuration Preferences **ISO and IFB** tab.

Note: If the destination of an ISO is a panel, then **Eavesdropping** must be enabled in Global Settings (Advanced Settings section) in order to activate the panel microphone if it is not already activated. If the destination is not a panel but a device such as a four-wire port Eavesdropping does not need to be enabled for the destination device.

17.15.5 Route monitor

Enable monitoring of an audio route. This creates a key that is available for assignment from Panel Programming. When the key is pressed, audio from the required crosspoint is routed to the panel with the key.

This allows panel C to monitor audio between ports A and B when Route Monitoring between A and B is enabled.

17.15.6 Mute relay

This function enables a panel's mute relay to activate automatically whenever the panel talks to a specific port or entity (PL, Group, IFB). The mute relay is a general purpose relay whose contacts are connected to the Control DB-25 connector on the panel's rear panel. It is commonly used to mute a control room monitor speaker, but it can also be put to other uses, such as turning on a light or unlocking a door.

Note: The Mute Relay function is not available if you configure the V-Series panel with a second additional sub-channel that has function Two-Way Radio, Partyline or HelixNet.

17.15.7 Preset talk

This option enables setting preset talk paths from an interface port to any other destination in either the local or a remote system.

Preset talks are similar to routes, except they can be configured to activate only when a call signal is received at this port from an external device, such as a radio or telephone or LQ-SIP or external partyline (CCI-22).

17.15.8 Preset listen

This options enables setting preset listen paths from an interface port to any other destination in either the local or a remote system. Preset listens are similar to routes, except they can be configured to activate only when a call signal is received at this port from an external device, such as a radio, telephone or CCI-22.

17.15.9 Preset call

Preset Call is used to send a call signal to a group or a port on either the local system or a remote system.

A panel receives the preset call signal as an incoming call tally but without the audio. If Audible Alerts is set for the panel, then the panel receives three beeps at either its loud speaker or headset speaker.

If the source interface is a TEL-14 telephone module, and Auto Answer is set to off, then the call signal is repeated every time a ring signal is received.

If the destination is a CCI-22 or FOR-22 module, the output is driven high during the call signal.

17.15.10 Call signal to a telephony interfaces

To enable an audible warning when a call is made from an external telephone to the TEL-14 module, set **Local Advanced > Preset Call**.

Call signal tones must also be enabled at the destination panel in the **Cards and Ports** screen.

While the phone is ringing, a call signal is sent to the panel. Call signal tones are sent to the panel every time a pulse is received from the TEL-14. The label for the TEL-14 port is placed in the Answerback stack of the panel, and an incoming call tally is displayed on both the Reply key and any configured key to that port.

17.15.11 Nearby panels

This function is used to prevent audio feedback (howlround) between panels located physically nearby each other. When enabled, audio from the source panel is prevented from reaching the destination panel, and signalization is also suppressed. The advanced setting **Nearby Panel Partial** in **Cards and Ports** can be used to route audio from nearby panels to the headset rather than suppressing it.

17.16 Fonts

Many fonts are supported by Eclipse HX systems allowing suitable panels to display labels in Latin and certain non-Latin scripts. The fonts supported by Eclipse HX systems are described below with the panel support.

Eclipse HX has additional font support for the V-Series panels:

- **Basic Latin.** The backslash is a Yen character. This is a size-maximized font (no descenders, lower-case characters are not relative in size to upper-case characters). This covers Unicode 32 to 127 (decimal), 0x20 to 0x7F (hex). The V-Series panel display supports ten characters.
- **Cyrillic.** This is a normal, relatively-sized font. The V-Series panel display supports ten characters. Covers Unicode 1024 to 1279 (decimal), 0x400 to 0x4FF (hex) with some missing characters.
- **Hiragana.** The V-Series panel display supports five characters. This covers the codepoint range 12352 to 12447 (decimal), 0x3040 to 0x309F (hex).
- **Full-width Katakana.** The V-Series panel display supports five characters as this is a normal wide font. This covers the codepoint range 12448 to 12543 (decimal), 0x30A0 to 0x30FF (hex) with some missing characters.
- **Kanji.** There are about 17,000 out of the 21,000 characters. The V-Series panel display supports five characters. This covers the codepoint range 19968 to 40895 (decimal), 0x4E00 to 0x9FBF (hex).
- **Hangul.** The V-Series panel display supports five characters, codepoint range is 44032 to 55215 (decimal), 0xAC00 to 0xD7AF (hex).
- **Half-width katakana.** The V-Series panel supports ten characters. The codepoint range is 65376 to 65440 (decimal), 0xFF60 to 0xFFA0 (hex).
- **Arabic.** The V-Series panel supports the Basic Arabic character set 0x0600 to 0x06FF.

- **Hebrew.**

17.16.1 Basic Latin

Basic Latin labels can be displayed on all the panels with a display capability. The maximum number of characters displayed depends on the type of panel.

17.16.2 Cyrillic

Cyrillic labels require Russian language support to be installed in Windows and either an ASCII keyboard with Russian character support or a Cyrillic keyboard. Cyrillic is only supported on V-Series panels.

17.16.3 Hangul

Hangul labels require Korean language support to be installed in Windows and either an ASCII keyboard with Korean language support or a Korean language keyboard. Hangul is only supported on V-Series panels.

17.16.4 Hiragana, Katakana and Kanji

Hiragana, Katakana and Kanji labels require Japanese language support to be installed in Windows and either an ASCII keyboard with Japanese character support or a Japanese language keyboard.

Hiragana, Katakana, half-width Katakana and Kanji labels can be displayed on V-Series panel only while some other panel types can support half-width Katakana. If an attempt is made to place a Hiragana, Katakana or Kanji label onto a panel with a display that is not compatible the label either fails to display correctly (may display question marks) or does not display at all.

17.16.5 Arabic

The V-Series panel supports the Basic Arabic character set 0x0600 to 0x06FF. The following are not supported:

- Arabic Extended-A
- Arabic Presentation Forms A
- Arabic Presentation Forms B
- Rumi Numeral Symbols
- Arabic Mathematical Alphabetic Symbols

The Arabic characters are drawn right to left unless it is an Arabic number 0 to 9 (0x0660 to 0x0669) which is written left to right.

The Unicode Characters in the General Punctuation Block characters 0x2000 to 0x206F are stripped out of the text string.

17.16.6 Half-width Hiragana, Katakana and Kanji compatible panels

The following panels can display half-width Katakana labels:

- V12LD
- V24LD
- V12LDD
- V12PD
- V24PD
- V12PDD
- V12RD
- V24RD
- V12RDD
- V12LDE
- V12PDE
- V12RDE

Katakana and Kanji labels may be entered in the same way as normal labels provided the prerequisite software and hardware is present.

17.16.7 Dynam-EC preferences

From **Configuration > Preferences > Dynam-EC** you can select the type of audio level metering to be used by the system.

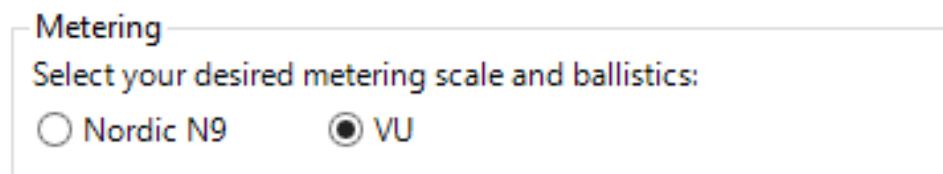

Figure 17-44 Dynam-EC Options Metering Scale and Ballistics

The metering scale and ballistics options specify how the audio levels are scaled and displayed.

The Nordic N9 option displays the audio level as a peak programme meter (PPM) and gives an accurate level reading. The scale is of the type used in Scandinavia.

The VU option displays the audio level as a Volume Unit (VU) meter and uses Root Mean Square voltage to display the audio level. This is a commonly used type of audio metering but does not always give the most accurate reading.

The VU meter scale has zero point at +4dBu with a decibel scale ranging non-linearly from 20dB below this point to 3dB above.

18 Configuring audio and conference routing

18.1 Partylines

An EHX partyline is a virtual partyline. When assigned to panel keys, it enables anyone in the system who activates a talk or listen (or both) to that partyline label to talk/listen to anyone else who has joined the partyline at the same time.

A partyline is typically used when several users, such as beltacks or camera intercoms, are engaged in a specific common activity and they need to talk and/or listen to each other all the time.

EHX permits the assignment of panels to a partyline. **However, this is normally completed in the Panel Programming screen by assigning the partyline label onto the panel.**

Note: Because partylines and Fixed Groups are now viewed as a global item across all systems (they work inter-system), Partyline and Fixed Group alias names are no longer displayed in remote systems. All Partylines and Fixed Groups should be given a unique name and global number.

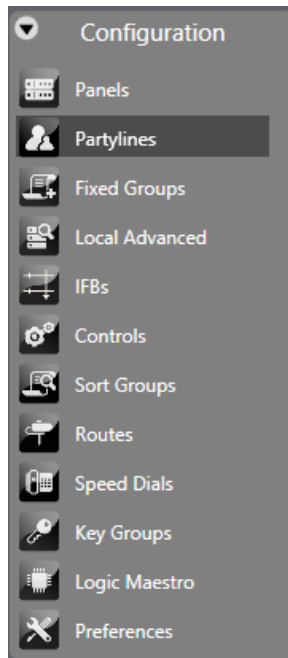

Figure 18-1 Configuration Menu

18.1.1 Adding and deleting partylines

To create a partyline and assign permanent members to that party:

- 1) Select **Configuration > Partylines**. This opens the **Partylines** configuration screen.

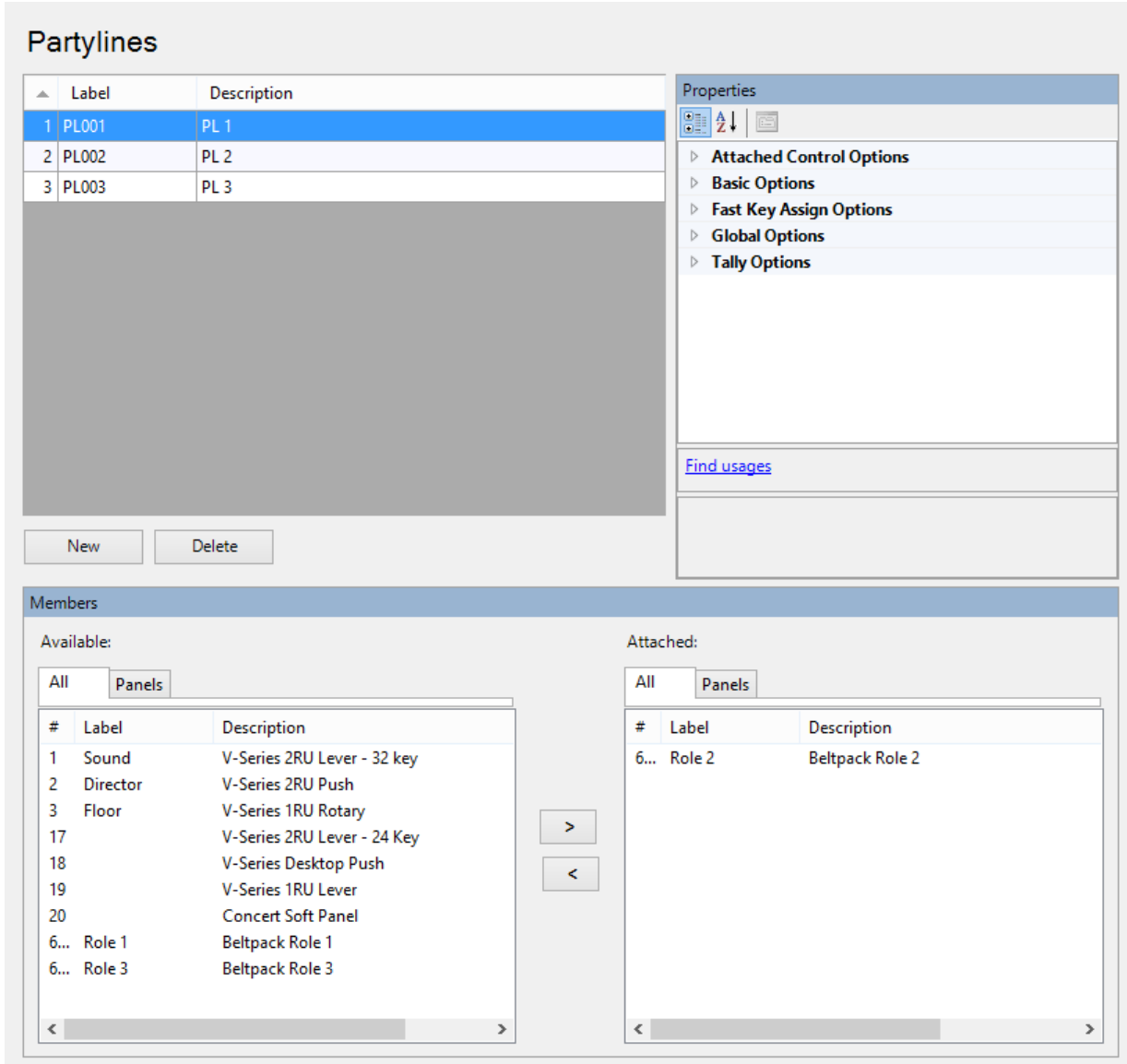

Figure 18-2 Partyline Setup Screen

- 2) Click **New** at the bottom left of the **Partylines** window.
- 3) Change the **Label** and **Description** fields as required.
- 4) To add or remove members, select the required member in the **Available** or **Attached** pane.

- 5) To add members, click > in the section between the lower windows to transfer the members to the **Attached** window.

Note: Double-clicking on the required item transfers it to the **Attached** window. Also, right clicking on a member of the **Available** group displays a menu allowing it to be attached.

The **#** button on the Available and Attached panes sorts the members by port number in ascending or descending order, preceded by non-port items such as controls.

The **Label** button sorts the members by name alphabetically and the **Description** button sorts the members alphabetically by description. The tabs above the Available and Attached panes filter the members by type.

Note: If your configuration contains linked matrices, and you add or remove partyline members, you might see the following message when you apply changes to the matrix:

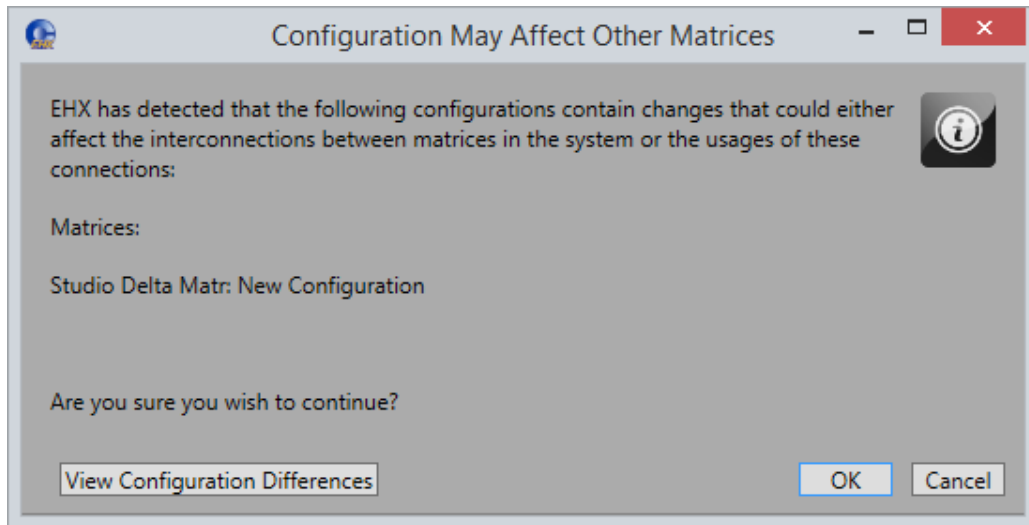

Figure 18-3 Configuration may affect other matrices

Click **View Configuration Differences** to see a list of changes that affect the intercommunication between Matrices. You are advised to Apply Changes to all Matrices.

Click **OK** to continue, or **Cancel**.

- 6) Right-click on a member in the **Attached** pane to open a configuration menu and select whether the attached member is Talk, Listen or Talk and Listen.
- 7) Apply to all matrices.

The partyline label can now be programmed onto a panel key.

The **#** button on the Available and Attached panes sorts the members by port number in ascending or descending order, preceded by non-port items such as controls.

The **Label** button sorts the members by name alphabetically and the **Description** button sorts the members alphabetically by description.

The tabs above the Available and Attached panes filter the members by type.

When a partyline is created, the configuration must be applied to all linked matrices. It is not sufficient to only apply to the matrix that hosts the partyline, the new configuration must be applied to all matrices that wish to talk or listen to that partyline.

The recommended use of this feature is that all partylines are configured and then applied to all matrices. The Dynam-EC software can then be used to manipulate these partylines in an online fashion (for example, use Dynam-EC to assign members from the entire linked set to the partyline).

To delete a partyline:

- 1) Select **Configuration > Partylines**. This opens the **Partylines** configuration screen.
- 2) Select the partyline to delete, and click **Delete**.

18.1.2 Partyline attached controls

Controls can be attached to partylines that allow a Route, Relay or Speed Dial to be activated via a secondary action.

- 1) Select **Configuration > Partylines**.
- 2) Create a partyline or select a partyline that was been previously created.
- 3) Expand **Attached Control** in the **Properties** window.
- 4) Select **Secondary Action** in the **Attached Control** list.
- 5) Select the drop down arrow and select the required control.

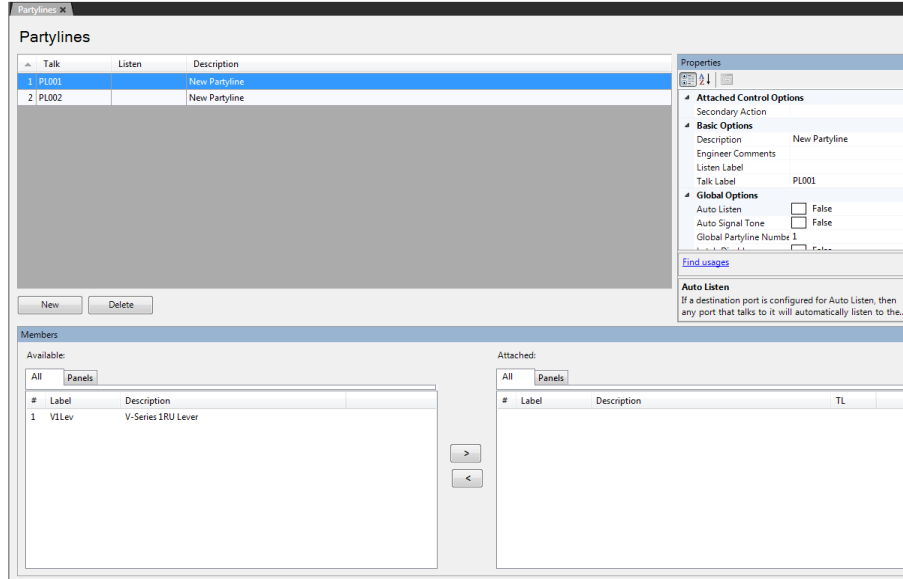

Figure 18-4 Partyline Attach Control Screen

18.1.3 Partyline basic options

To enable/disable Basic Options

- 1) Select **Configuration > Controls**.
- 2) Create a partyline or select a partyline that was been previously created
- 3) From the **Properties** window, expand **Basic Options**.
- 4) To edit an item in the **Basic Options** list, select the item in the left hand column and edit the text in the right hand column. You can edit the following:
 - **Description** – An optional description of the port.
 - **Engineer Comments** – An optional comment.
 - **Listen Alt Text** – Alternative text that is shown when the ALT TEXT special key is activated.
 - **Listen Label** – A label used for identificaton that can be up to 10 characters long including spaces. For split labels, the maximum length is five characters.
 - **Talk Alt Text** - Alternative text that is shown when the ALT TEXT special key is activated.

- **Talk Label** - A label used for identification that can be up to 10 characters long including spaces. For split labels, the maximum length is five characters.

18.1.4 Partyline global options

To enable/disable Global Options

- 1) Select **Configuration > Controls**.
- 2) Create a partyline or select a partyline that was been previously created.
- 3) From the **Properties** window, expand **Global Options**.
- 4) To edit an item in the **Global Options** list select the item in the left hand column and edit the text in the right hand column. You can edit the following:
 - **Auto Listen** - Any port that talks to a destination port automatically hears the audio from the destination port.
 - **Dial Code** - Defines the dial code used in fast key assign operations.
 - **Global Partyline Number** - This is the unique number given to this partyline in the linked set. Partylines are globally numbered, giving them a unique, global identity throughout the Eclipse HX system. If a partyline is assigned the number 001, then no subsequently created partyline will be given this number regardless of which matrix the partyline is created on.
 - Partylines are numbered based on local creation order.
 - **Latch Disable** - The setting determines if the partyline panel key is latching or non-latching.
 - **Prevent Reply Signalization** - Prevents key signalization for the port appearing on the reply key of any panels.

18.1.5 Partyline fast key assign options

To enable/disable Local Key Assignment Mode Options

- 1) Select **Configuration > Controls**.
- 2) Create a partyline or select a partyline that was been previously created.
- 3) From the **Properties** windows, expand **Fast Key Assign Options**.

- 4) To edit an item, select the item in the left hand column and edit the text in the right hand column. You can edit the following:
- **Default Assign as Talk and Forced Listen.** When true the default for a key assigned to this label is Talk and Forced Listen.
 - **Enable Assignment as Listen.** This must be enabled to allow a V-Series panel operator to assign a listen key to this label. If it is not enabled a V-Series panel operator cannot assign a listen key to the label.
 - **Enable Assignment as Talk.** This must be enabled to allow a V-Series panel operator to assign a talk key to this label. If it is not enabled a V-Series panel operator cannot assign a talk key to the label.
 - **Protect Port from Assignment.** When this option is enabled the port cannot be locally assigned as a talk/listen key by another panel.

18.1.6 Partyline tallies

To enable/disable Tallies

- 1) Select **Configuration > Controls**.
- 2) Create a partyline or select a partyline that was been previously created.
- 3) From the **Properties** window, expand **Tally Options**.
- 4) Select **In Use Tally** in Tally Options.
- 5) Select the drop down arrow and select the required status.

This allows the system to set a tally (flashing LED) on all the panel keys that are assigned to the partyline whenever a talk is active on the partyline.

In the case of multiple matrices in a linked set the **In Use** tally is broadcast to all other systems in the linked set. In this way the feature is seamless over the matrices in a linked set.

The default is enabled.

18.2 Fixed groups

A fixed group is a list of ports including panels, interfaces and IFBs that are represented by a single, fixed group label. The fixed group label can be assigned to selector keys on one or more panels, which when activated, simultaneously access all members of that fixed group.

Note: For information about Call Management Groups, see section **18.2.4 Call Management Group options**.

Note: Because partylines and Fixed Groups are now viewed as a global item across all systems (they work inter-system), partyline and Fixed Group alias names are no longer displayed in remote systems.

Note: All partylines and Fixed Groups should be given a unique name and global number.

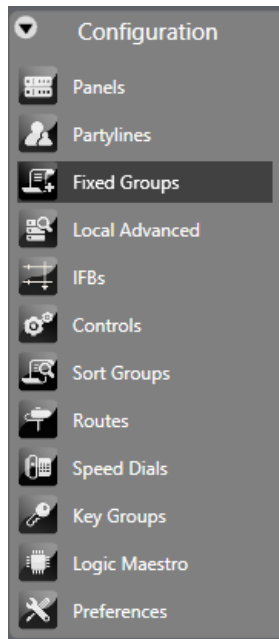

Figure 18-5 Eclipse HX Setup Menu

18.2.1 Adding and deleting fixed groups

To create a Fixed Group and assign members to that group, do the following:

- 1) Open Configuration > Fixed Groups.

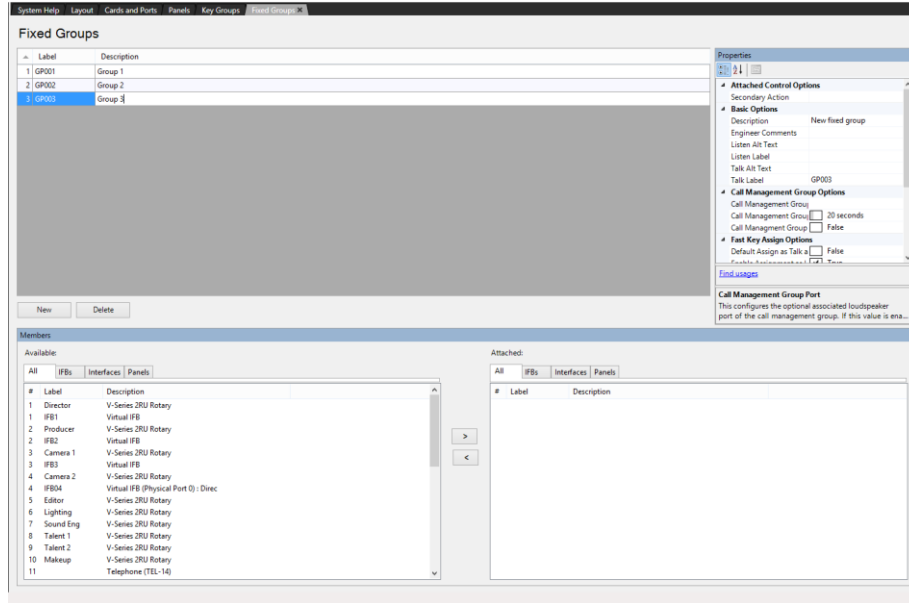

Figure 18-6 Fixed Groups List

- 2) Select the **New** button at the bottom left of the Groups window (top left window of the screen).
- 3) Change the **Label** and **Description** fields as required.
- 4) To add members, select the required members from the **Available** window (bottom left of the screen) and click on the **>** in the section between the lower windows to transfer the members to the **Attached** window in the bottom right of the screen.

Alternatively double-clicking on the required item transfers it to the **Attached** window. Also right clicking on a member of the **Available** group displays a menu allowing it to be attached.

The **#** button on the Available and Attached panes sorts the members by port number in ascending or descending order, preceded by non-port items such as controls.

The **Label** button sorts the members by name alphabetically and the **Description** button sorts the members alphabetically by description. The tabs above the Available and Attached panes filter the members by type.

- 5) To remove members from the group select the members to be removed in the **Attached** window and click on the **<** symbol in the central section to return them to the **Available** window.

Alternatively double-clicking on the required member moves it back to the **Available** group. Also right clicking on a member of the Attached group displays a menu allowing it to be detached.

Note: If you add or remove **remote** members in a fixed group, you might see the following message when you apply changes to the matrix:

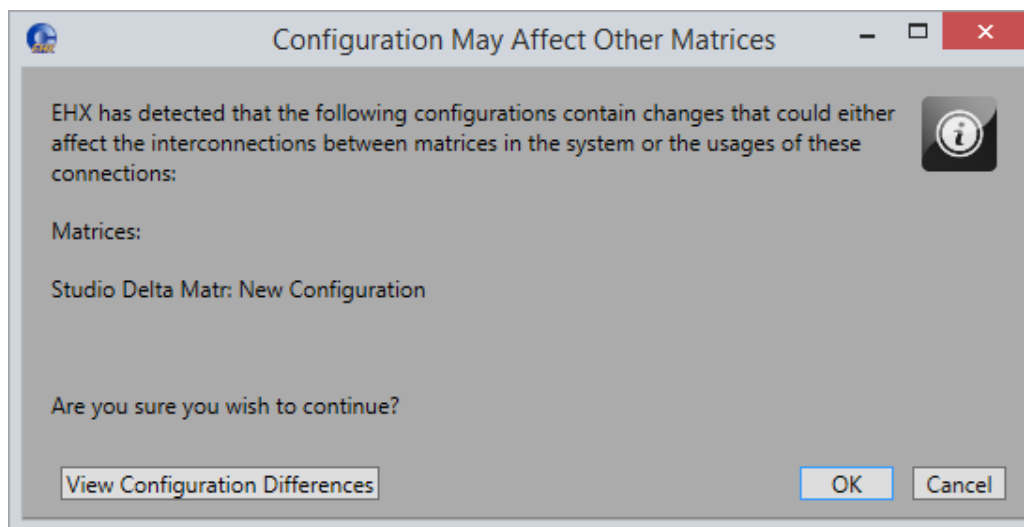

Figure 18-7 Configuration may affect other matrices

Click **View Configuration Differences** to see a list of changes that affect the intercommunication between Matrices. You are advised to Apply Changes to all Matrices.

Click **OK** to continue, or **Cancel**.

Fixed Groups can be made up of local and remote members (see section **25 Networking**).

Note: If you select a fixed group and select **Find Usages** in the **Properties Pane**, a list of panels or routes that are assigned to this fixed group appears.

To delete a group:

- 1) Select **Configuration > Fixed Groups**. This opens the **Fixed Groups** configuration screen.
- 2) Select the group to delete, and click **Delete**.

18.2.2 Fixed group attached controls

Attachments can be attached to Fixed Groups that allow a Route, Relay or Speed Dial to be activated via a secondary action.

- 1) Open **Configuration > Fixed Groups**.

- 2) Create a Fixed Group or select a Fixed Group that was been previously created.
- 3) From the **Properties** window, expand **Attached Control**.
- 4) Select **Secondary Action** in the **Attached Control** list.
- 5) Select the drop down arrow and select the required control.

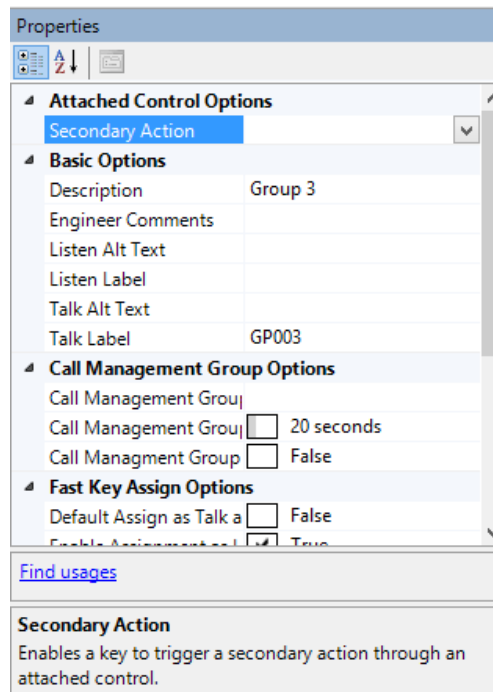

Figure 18-8 Fixed Group Attach Control Screen

18.2.3 Fixed group basic options

Basic Options displays the fixed information about a group and can be used to edit the group description, Talk and Listen, ALT Text and Talk and Listen labels.

To enable/disable Basic Options

- 1) Open **Configuration > Fixed Groups**.
- 2) Create a Fixed Group or select a Fixed Group that was been previously created.
- 3) From the **Properties** window, expand **Basic Options**.
- 4) To edit an item in the **Basic Options** list select the item in the left hand column and edit the text in the right hand column. You can edit the following:

- **Description** – An optional description of the port.
- **Engineer Comments** – An optional comment.
- **Listen Alt Text** – Alternative text that is shown when the ALT TEXT special key is activated.
- **Listen Label** – A label used for identification that can be up to 10 characters long including spaces. For split labels, the maximum length is five characters.
- **Talk Alt Text** - Alternative text that is shown when the ALT TEXT special key is activated.
- **Talk Label** - A label used for identification that can be up to 10 characters long including spaces. For split labels, the maximum length is five characters.

18.2.4 Call Management Group options

Call Management Group options allow you to add extra functionality to a fixed group configuration. These features can be used when you need to treat a group as a pool of responders; where any group member can take a call. There are two modes of operation:

- Group to Group
- Group call pick up

Any member from a defined group can call another group, alerting all members of that group. Any member of the group being called can pick up the incoming call and this creates a point-to-point audio connection.

Use this feature when members of separate groups or teams need to talk to each other, for example members of master transmission control room (a broadcasting scenario) need to contact members of a studio.

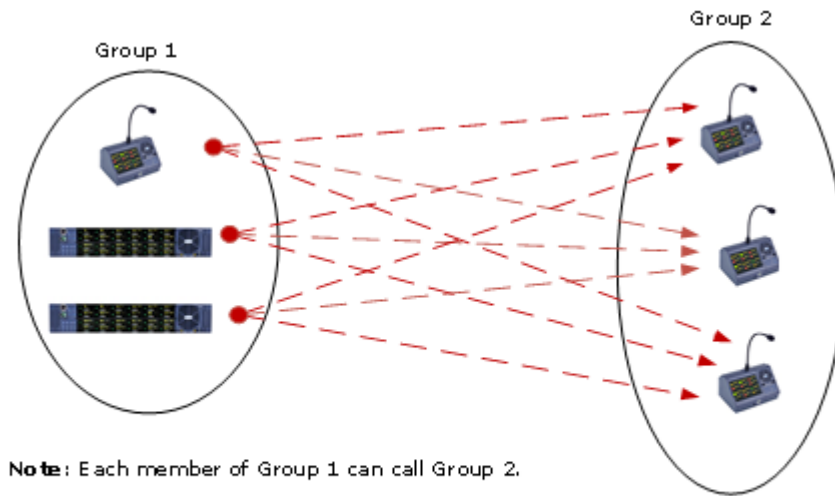

Call management group: group call group

Figure 18-9 Call Management Group

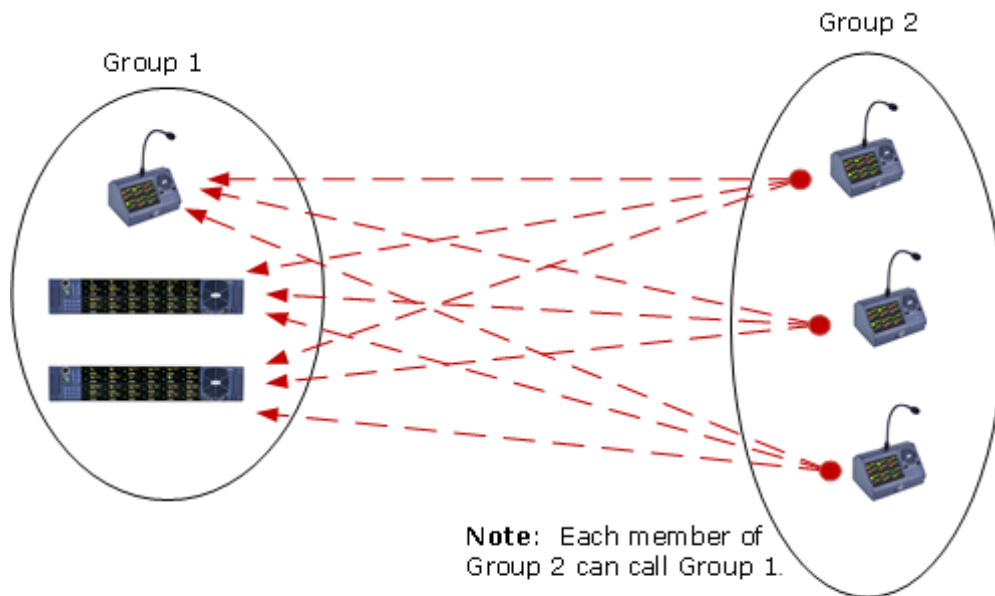

Call management group: group call group

Figure 18-10 Call Management Group

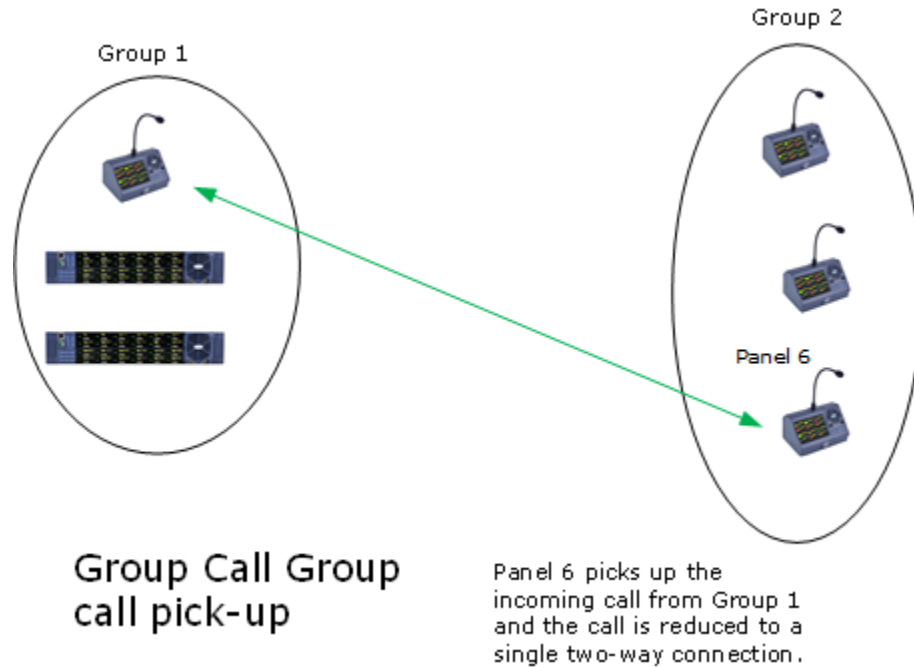

Figure 18-11 Call Management Group call pick-up

There are a number of set-up options available:

- A speaker port can be configured to broadcast incoming calls to a group.
- An external line can be a participant caller.
- An individual can be configured to call a group.
- Once a point-to-point connection has been made, the connection can be set to persist for a specified time (0-60 secs) after the call has been released by users. This means that the call can be re-activated without having to be re-broadcast to the whole group.

When no speaker port is specified, and multiple members are calling multiple members, both groups **MUST** be local to the same matrix. Setting a speaker port in **Matrix>Configuration>Fixed Groups>Properties** enables an external line.

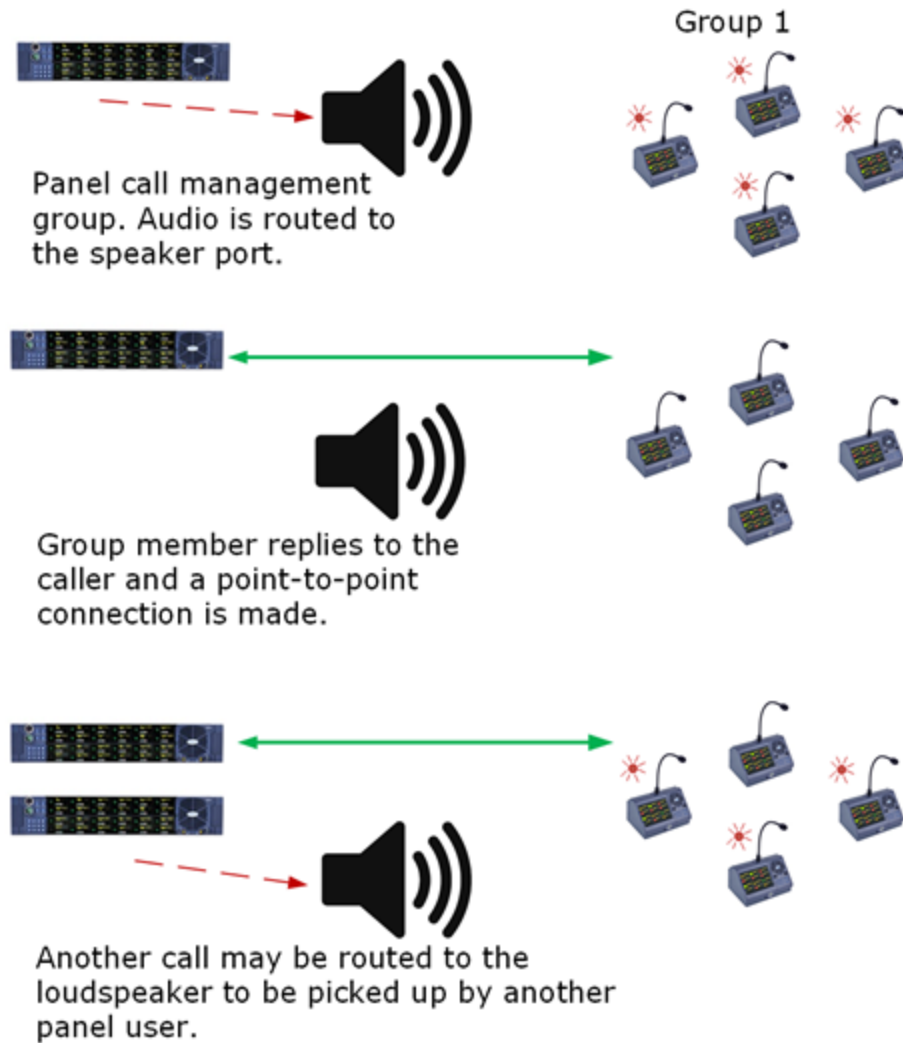

Figure 18-12 Speaker port to group call

Configuring a call management group

To configure a call management group:

- 1) Open **Configuration > Fixed Groups**.
- 2) Create a fixed group that contains all the panels to be included in the call management group.
- 3) From the **Properties** window, expand **Call Management Group Options**.
- 4) Ensure the **Call Management Group** option is enabled. Click the dropdown arrow to the right of this option to set it to **True**.

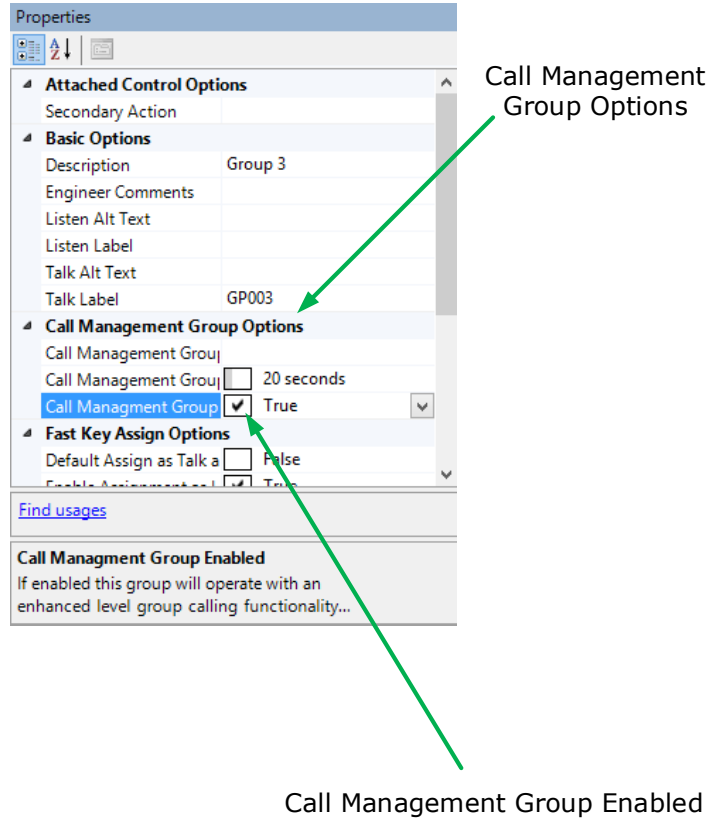

Figure 18-13 Call management group

This enables **Call Management Group** functionality.

- 5) Set the **Call Management Group Timeout** as required (0-60 secs).

Configuring a loudspeaker port for a call management group:

Follow steps 1 – 4 above.

- 1) Click the dropdown arrow to the right of **Group Management Group Port** to see available ports. Select port.

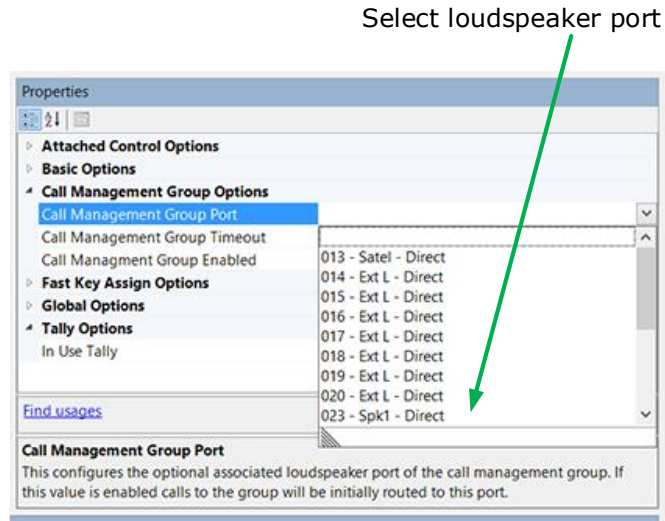

Figure 18-14 Select port

This enables **Speaker Port to Group Call**. To disable this option, ensure that this option field is blank (click the blank placeholder at the top of the list).

Note: You will need to enable this option if you wish to use an external line with the call management functionality.

18.2.5 Fixed group global options

To enable/disable Global Settings

- 1) Open **Configuration > Fixed Groups**.
- 2) Create a Fixed Group or select a Fixed Group that was been previously created.
- 3) Expand **Global Options** in the **Properties** window.
- 4) To edit an item in the **Global Options** list select the item in the left hand column and edit the text in the right hand column. You can edit the following:
 - **Dial Code** – This is used during fast key assign operations on the panel.
 - **Global Group Number** – A global identifier for the group. Fixed groups are globally numbered, giving them a unique, global identity throughout the Eclipse HX system. If a Fixed Group is assigned the number 001, then no subsequently created group will be given this number regardless of which Matrix the Fixed Group is created on. Fixed Groups are numbered based on local creation order.

- **Latch Disable** – Disables key latching on the panel so that keys remain active only when they are held down or pressed.
- **Page Override** – Enables you to override the headset or speaker levels when calling a group. This only works if group members have **Page Override Allowed** enabled.

5) Select the drop down arrow and select the required status.

18.2.6 Fixed group fast assign options

The **Fast Key Assign Options** list display items which relate to local key assignment and fast assign mode available on certain panel types. Fast key assign options can only be applied to a Fixed group that is already attached to a Sort Group.

To enable/disable Fast Key Assign Options

- 1) Open **Configuration > Fixed Groups**.
- 2) Create a **Fixed Group** or select a Fixed Group that was been previously created.
- 3) Make sure the **Fixed Group** is attached to a **Sort Group** then;
- 4) From the **Properties** window, expand **Fast Key Assign Options**.
- 5) Select the required options:
 - **Default Assign as Talk and Forced Listen**. When true the default for a key assigned to this label is Talk and Forced Listen.
 - **Enable Assignment as Listen**. This must be enabled to allow a V-Series panel operator to assign a listen key to this label. If it is not enabled a V-Series panel operator cannot assign a listen key to the label.
 - **Enable Assignment as Talk**. This must be enabled to allow a V-Series panel operator to assign a talk key to this label. If it is not enabled a V-Series panel operator cannot assign a talk key to the label.
 - **Protect Port from Assignment**. When this option is enabled the port cannot be locally assigned as a talk/listen key by another panel.
- 6) Select the drop down arrow and set the required status (True or False).
The status box is checked or unchecked to indicate True or False.

18.2.7 Fixed group tallies

To enable/disable Tallies

- 1) Open **Configuration > Fixed Groups**.
- 2) Create a Fixed Group or select a Fixed Group that was been previously create.
- 3) From the **Properties** window, expand **Tally Options**.
- 4) From the **Tally Options**, select **In Use Tally**.
- 5) Select the drop down arrow and select the required status.

This allows the system to set a tally (flashing LED) on all the panel keys that are assigned to the Fixed Group whenever a talk is active on the Fixed Group. In the case of multiple matrices in a linked set the 'In Use' tally is broadcast to all other systems in the linked set. In this way the feature is seamless over the matrices in a linked set.

The default is disabled.

18.2.8 Sort function on fixed groups members

EHX provides a sort capability that allows the EHX user a quick and easy way of grouping common items such as FOR-22s together. The sort function has been implemented in both the **Attached** window and **Available** window.

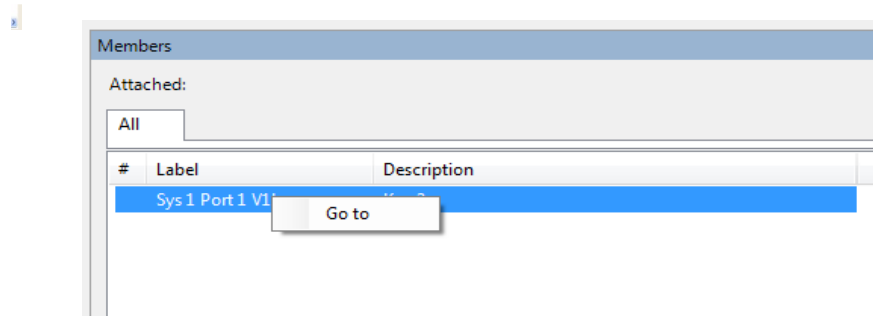

Figure 18-15 Group Members List

- 1) To operate the sort function, open **Configuration > Fixed Groups**.
- 2) Use the **All** tab on the Attached window to display all the members of the groups, or the **Interfaces** tab to display only the interfaces in the group or the **Panels** tab to list the panels in the group.

The **#** tab sorts the group members by ascending or descending port number.

18.3 Controls

From the **Controls** screen you can create and delete controls, and configure them. You can then attach, for example, relays, routes and speed dials.

Relay options, routes and speed dials can only be accessed by being first placed inside a control. A control can then be placed on a panel key for activation.

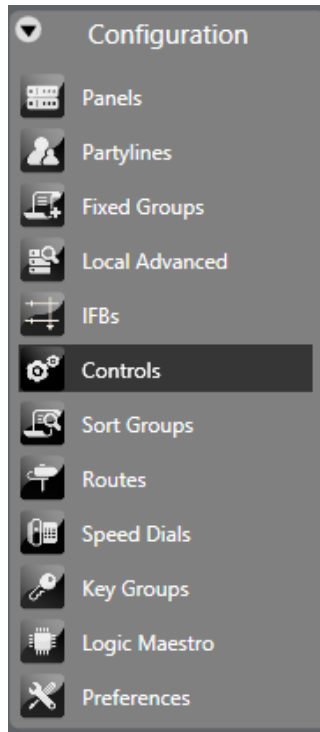

Figure 18-16 Configuration Menu

18.3.1 Adding and deleting controls

- 1) Select **Configuration > Controls**.

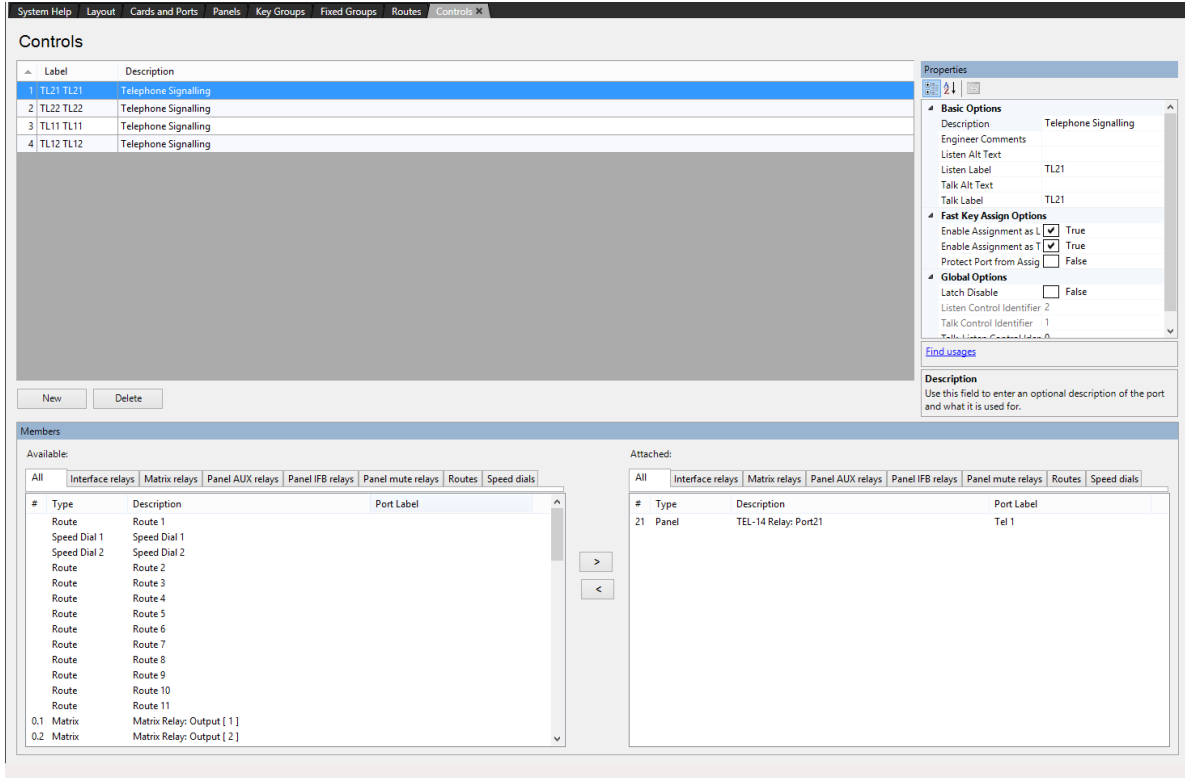

Figure 18-17 Control Manager Screen

- 2) Select the **New** button at the bottom left of the Controls window (top left window of the screen).
- 3) Change the **Label** and **Description** fields as required.
- 4) To add members, select the required members from the **Available** window (bottom left of the screen) and click on the **>** in the section between the lower windows to transfer the members to the **Attached** window in the bottom right of the screen.

Alternatively double-clicking on the required item transfers it to the **Attached** window. Also, right clicking on a member of the **Available** group displays a menu allowing it to be attached.

The **#** button on the Available and Attached panes sorts the members by port number in ascending or descending order, preceded by non-port items such as controls.

The **Label** button sorts the members by name alphabetically and the **Description** button sorts the members alphabetically by description. The tabs above the Available and Attached panes filter the members by type.

- 5) To remove members from the group select the members to be removed in the **Attached** window and click on the < symbol in the central section to return them to the **Available** window.

To delete a Control:

- 1) Select **Configuration > Controls**. This opens the **Controls** configuration screen.
- 2) Select the Control to delete, and click **Delete**.

18.3.2 Controls basic options

To enable/disable Basic Options:

- 1) Select **Configuration > Controls**.
- 2) Create a Control or select a Control that was been previously created.
- 3) From the **Properties** window, expand **Basic Options**.
- 4) To edit an item in the **Basic Options** list, select the item in the left hand column and edit the text in the right hand column. You can edit the following:
 - **Description** – An optional description of the port.
 - **Engineer Comments** – An optional comment.
 - **Listen Alt Text** – Alternative text that is shown when the ALT TEXT special key is activated.
 - **Listen Label** – A label used for identification that can be up to 10 characters long including spaces. For split labels, the maximum length is five characters.
 - **Talk Alt Text** - Alternative text that is shown when the ALT TEXT special key is activated.
 - **Talk Label** - A label used for identification that can be up to 10 characters long including spaces. For split labels, the maximum length is five characters.

18.3.3 Global options

To enable/disable Global Options

- 1) Select **Configuration > Controls**.
- 2) Create a Control or select a Control that was been previously created.

- 3) From the **Properties** window, expand **Global Options**.
- 4) To edit an item in the **Global Options** list, select the item in the left hand column and edit the text in the right hand column. You can edit the following:
 - **Latch Disable** - Disables key latching on the panel so that keys remain active only when they are held down or pressed.
 - **Listen Control Identifier 2** – An identifier for the Control when used as a listen destination.
 - **Talk Control Identifier 1** - An identifier for the Control when used as a talk destination.
 - **Talk-Listen Control Identifier 0** - An identifier for the Control when used as a talk and listen destination.

18.3.4 Fast Key Assign Options

The **Fast Key Assign Options** list display items which relate to local key assignment and fast assign mode available on certain panel types.

To enable/disable Fast Key Assign Options

- 1) Open **Configuration > Controls**.
- 2) Create a **Control** or select one that was been previously created.
- 3) From the **Properties** window, expand **Fast Key Assign Options**.
- 4) Select the required options:
 - **Default Assign as Talk and Forced Listen**. When true the default for a key assigned to this label is Talk and Forced Listen.
 - **Enable Assignment as Listen**. This must be enabled to allow a V-Series panel operator to assign a listen key to this label. If it is not enabled a V-Series panel operator cannot assign a listen key to the label.
 - **Enable Assignment as Talk**. This must be enabled to allow a V-Series panel operator to assign a talk key to this label. If it is not enabled a V-Series panel operator cannot assign a talk key to the label.
 - **Protect Port from Assignment**. When this option is enabled the port cannot be locally assigned as a talk/listen key by another panel.
- 5) Select the drop down arrow and set the required status (True or False).

- 6) The status box is checked or unchecked to indicate True or False.

18.3.5 Panel Auxiliary and Panel Mute

The Available and Attached windows have tabs for the various types of functions, allowing them to be filtered for ease of selection. Two of the tabs are **Panel AUX relays** and **Panel mute relays**.

These functions correspond to these relay outputs in the I-Station documentation. In the case of V-Series panels the output relays are labelled as 1 and 2. The correspondence between the labels in EHX and the panel hardware is:

- Panel mute relay - relay output 1.
- Panel AUX relay - relay output 2.

18.4 Sort groups

Sort Groups are only available if a V-Series Panel is configured. Sort Groups are groups of other items such as controls, fixed groups, IFBs, interfaces, panels and partylines that can be treated as a single item and accessed in Key Assign mode to assign a member of the sort group to a key. Selecting Sort Groups in the EHX Setup menu displays the sort group editor.

18.4.1 Adding and deleting sort groups

- 1) Select **Configuration > Sort Groups**.

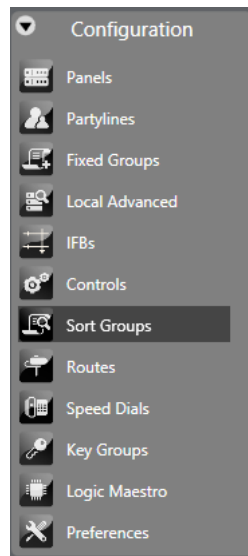

Figure 18-18 Sort Groups

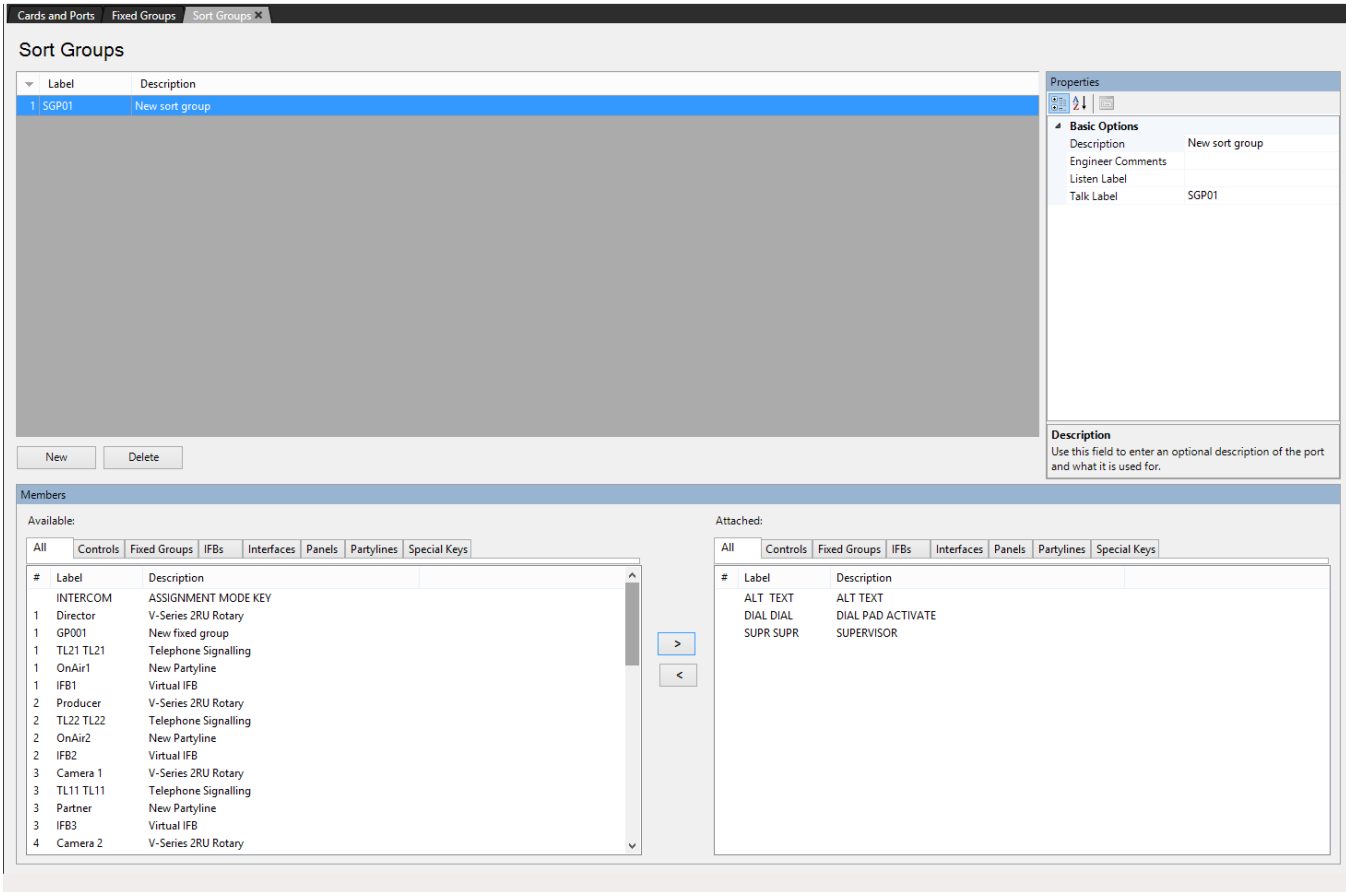

Figure 18-19 Sort Group Editor

- 2) Select the **New** button at the bottom left of the Sort Group window (top left window of the screen).
- 3) Change the **Label** and **Description** fields as required.
- 4) To add members, select the required members from the **Available** window (bottom left of the screen) and click on the **>** in the section between the lower windows to transfer the members to the **Attached** window in the bottom right of the screen.

Alternatively double-clicking on the required item transfers it to the **Attached** window. Also right clicking on a member of the **Available** group displays a menu allowing it to be attached.

The **#** button on the Available and Attached panes sorts the members by port number in ascending or descending order, preceded by non-port items such as controls.

The **Label** button sorts the members by name alphabetically and the **Description** button sorts the members alphabetically by description. The tabs above the Available and Attached panes filter the members by type.

- 5) To remove members from the group select the members to be removed in the **Attached** window and click on the < symbol in the central section to return them to the **Available** window.

To delete a Sort Group:

- 1) Select **Configuration > Sort Groups**. This opens the **Sort Groups** configuration screen.
- 2) Select the Sort Group to delete, and click **Delete**.
- 3) To set the properties of the sort group open the **Basic Settings** menu in the **Properties** window (top right).

18.4.2 Basic options

To enable/disable Basic Options

- 1) Open **Configuration > Sort Groups**.
- 2) Create a Sort Group or select a Sort Group that was been previously created.
- 3) From the **Properties** window, expand **Basic Options**.
- 4) To edit an item in the **Basic Options** list select the item in the left hand column and edit the text in the right hand column. You can edit the following:
 - **Description** – An optional description of the port.
 - **Engineer Comments** – An optional comment.
 - **Listen Alt Text** – Alternative text that is shown when the ALT TEXT special key is activated.
 - **Listen Label** – A label used for identification that can be up to 10 characters long including spaces. For split labels, the maximum length is five characters.
 - **Talk Alt Text** - Alternative text that is shown when the ALT TEXT special key is activated.
 - **Talk Label** - A label used for identification that can be up to 10 characters long including spaces. For split labels, the maximum length is five characters.

18.4.3 Scrolling assignment

You can assign sort groups to panel keys from the panel programming screen. See section **17 Panel programming**. To assign sort groups:

- 1) From **Palette > Special Entities**, drag the **ASSIGN** label to one of the panel keys.
- 2) Click on the required sort group in the palette, and then drag it to the required panel key and drop it over the display corresponding to the key. Click on the mouse to confirm the assignment.

Note: If there is no ASSIGN key, the following message appears:

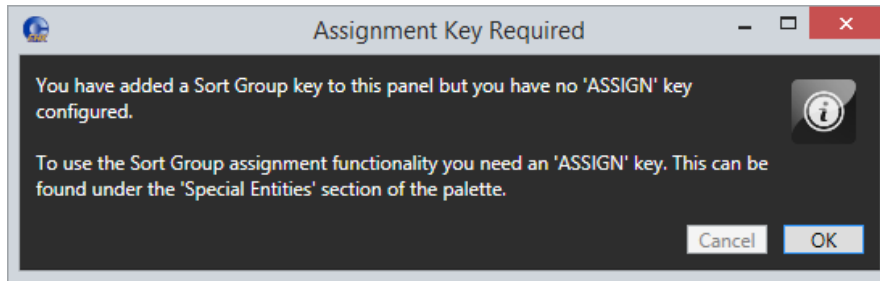

Figure 18-20 Assignment key required

When the sort group is assigned to the key, by default the first sort group entity is present on the key. You can select a different entity using the V-Series Panel rotary controller or up/down buttons.



Figure 18-21 Panel programming screen

18.5 Routes

A route is an audio path between two points in the matrix that can be activated by another intercom panel's selector key. From the Routes screen you can:

- Define the route origin and route target for each route
- Determine whether each route is activated with a talk key, a listen key, or both
- Enable a reverse listen (a reversal of the route's direction when it is activated by a Talk).

A route is defined by selecting a route origin, a route target, and providing a description. The origin can be any port in the local system.

An origin cannot be a nonport label, including a partyline or fixed group.

The target can be any audio label in the system including an IFB, partyline or a Group or remote ports, except a control label. When a route is activated, it sets a talk from the origin to the target.

To use a route, you must first create a control and add the route to the control. Then the control can be assigned to the panel or secondary action etc. to activate the control.

If the Action is set to Talk the route acts as a unidirectional audio path whenever a talk or listen to the route is activated. If the route action is set to Talk and Reverse Listen the route acts as a bi-directional audio path.

18.5.1 Adding and deleting a route

- 1) Open **Configuration > Routes**.

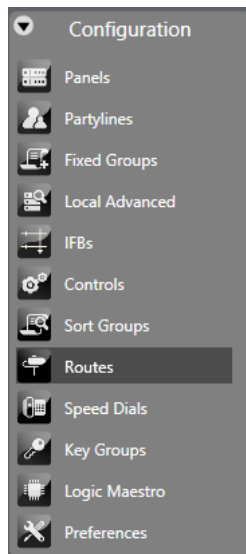

Figure 18-22 Routes

Figure 18-23 Routes

Routes							
Number	Description	Route Origin	Route Action	Route Target	Activate With Talk	Activate With Listen	
1	Route 1	Director	Calls (IFB) →	IFB1	<input checked="" type="checkbox"/>	<input checked="" type="checkbox"/>	
2	Route 2	Director	Calls (IFB) →	IFB1	<input checked="" type="checkbox"/>	<input checked="" type="checkbox"/>	
3	Route 3	Director	Calls (IFB) →	IFB1	<input checked="" type="checkbox"/>	<input checked="" type="checkbox"/>	
4	Route 4	Director	Calls (IFB) →	IFB1	<input checked="" type="checkbox"/>	<input checked="" type="checkbox"/>	
5	Route 5	Director	Calls (IFB) →	IFB1	<input checked="" type="checkbox"/>	<input checked="" type="checkbox"/>	
6	Route 6	Director	Inhibited from calling (IFB) ✕	IFB1	<input checked="" type="checkbox"/>	<input checked="" type="checkbox"/>	
7	Route 7	Director	Routed as destination of (IFB) ←	IFB1	<input checked="" type="checkbox"/>	<input checked="" type="checkbox"/>	
8	Route 8	Director	Routed as source to (IFB) →	IFB1	<input checked="" type="checkbox"/>	<input checked="" type="checkbox"/>	
9	Route 9	Director	Routed as return to (IFB) →	IFB1	<input checked="" type="checkbox"/>	<input checked="" type="checkbox"/>	
10	Route 10	Director	Listen to IFB Return ←	IFB1	<input checked="" type="checkbox"/>	<input checked="" type="checkbox"/>	
11	Route 11	Director	Monitor audio at IFB destinations ←	IFB1	<input checked="" type="checkbox"/>	<input checked="" type="checkbox"/>	

New Delete

Figure 18-24 Routes Configuration Screen

- 2) Select the **New** button at the bottom left of the Routes window (top left window of the screen), and then select either **Activate with Listen** or **Activate with Talk** or both.
- 3) Change the **Label** and **Description** fields as required.
- 4) Drag a source from the palette onto the **Route Origin** field.
- 5) Drag a target from the palette onto the **Route Target** field.
- 6) Assign a route action from the drop-down list:
 - Talk -the route acts as a talk only route from the source to the destination. Signalization appears on the destination.
 - Talk and Reverse Listen – audio is routed from the source to the destination and signalization appears on the destination. Audio is also routed from the destination to the source.
 - Reverse Listen – the source can listen to audio form the destination. No signalization appears on the source.
 - Inhibit Talk – all audio from the source to the destination is blocked.

If an IFB is configured as the route target, the following are available:

- Calls (IFB) – audio from the route origin is sent to the route target as an IFB caller.
- Inhibited from calling (IFB) – audio from the route origin is prevented from calling the route target IFB.
- Routed as destination of (IFB) – the route origin becomes a target of the IFB, and hears audio from the route target IFB.
- Routed as source to (IFB) – audio from the route origin is sent to the route target IFB as an IFB source.
- Routed as return to (IFB) – audio from the route origin is sent to the route target IFB as an IFB return
- Listen to IFB Return – audio from the route target IFB returns is sent to the route origin.
- Monitor audio at IFB destinations – the route target hears the same audio heard at the route target IFB destination.

After the route has been set up using this screen, it is possible to assign it to a label from the **Controls** screen. Within the Panel Programming screen and the Stacked Keys area, with the Control Label programmed onto a panel then double clicking this Label, the attachments to the Label are displayed.

Activate with talk

When this box is checked, the route activates whenever the control which contain the route is activated by a talk key.

Activate with listen

When this box is checked, the route activates whenever the control which contain the route is activated by a listen key.

Note: Activating the route by a listen has exactly the same effect as activating it by a talk unless the Reverse Listen option is selected making a bi-directional audio path between the source and destination.

Deleting a route

To delete a route:

- 1) Open **Configuration > Routes**.
- 2) Select the route to be deleted.
- 3) Click **Delete**.

18.6 Speed dials using SIP and TEL-14

Note: For more information about making and receiving telephone calls using SIP, see **21 Telephone audio routes in Eclipse matrices.**

18.6.1 Speed dial (DTMF sequences)

The MVX-A16 matrix card can generate DTMF Tones using the DTMF Daughter board fitted into the slots on the MVX-A16 card. DTMF Tones are the beeps made by a Touch Tone Telephone.

The Speed Dial screen defines the name, activation type DTMF Sequence and the source of the sequence which is currently a telephony interface (including SIP clients). There is a 23-digit limit on a DTMF Sequence.

The currently allowable dial sequences are as follows: The numbers through 0 – 9 the pound (#) and asterisk (*) characters. A DTMF Sequence is defined as a sequence of these numbers.

A Speed Dial must be attached to a control label, and then the control label is programmed onto the panel next to the label of the telephone. To Activate the Speed Dial activate the label to the telephony interface, and then activate the Control/Speed Dial label by latching the selector of the label.

18.6.2 Speed dial setup

To setup a speed dial:

- 1) Select **Configuration > Speed Dials.**

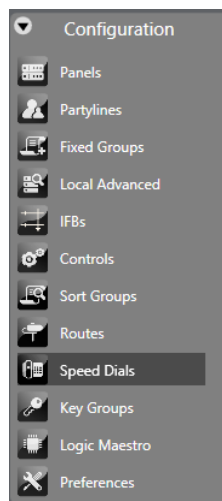

Figure 18-25 Speed Dials

Speed Dials					
Number	Description	Activate With Talk	Activate With Listen	DTMF Auto Dial	Speed Dial Source
1	ext 2005	<input checked="" type="checkbox"/>	<input checked="" type="checkbox"/>	2005	IVC_SIP#1
2	Speed Dial 2	<input checked="" type="checkbox"/>	<input checked="" type="checkbox"/>	2000	MVX SIP
3	Speed Dial 3	<input checked="" type="checkbox"/>	<input checked="" type="checkbox"/>	2000@10.60.11.118	IVC_SIP#1
4	Speed Dial 4	<input checked="" type="checkbox"/>	<input checked="" type="checkbox"/>		
5	Speed Dial 5	<input checked="" type="checkbox"/>	<input checked="" type="checkbox"/>		
6	Speed Dial 6	<input checked="" type="checkbox"/>	<input checked="" type="checkbox"/>		

New Delete

Figure 18-26 Speed Dial Setup

- 2) To add a new speed dial, click **New** at the bottom left of the speed dial window. A new speed dial entry is created with the default description highlighted.
- 3) Complete the **Description**, **Activate with Listen**, **Activate with Talk**, **DTMF Auto Dial number** and the **Speed Dial Source** fields (the port that the DTMF tones are sent from).

Note: A comma (,) may be placed in the DTMF sequence to add a pause of 500ms between digits or before the DTMF sequence if required.

- 4) Create a control using the Controls link on the Configuration menu. Then attach the speed dial to the control by selecting the control so that it is highlighted. Then select the required speed dial from the Available members pane and click on the right arrow to transfer it to the Attached members pane. The speed dial is now attached to the control.
- 5) To detach a speed dial from a control simply select the control and then select the speed dial to be detached in the **Attached** members pane. Click the left arrow to move it back to the **Available** pane.
- 6) Program the label of the telephony Interface and the Control to activate the Speed Dial from the panel Programming screen.

- 7) Apply to the Matrix by an **Apply Label Changes** download.
- 8) To activate the Speed Dial, select the Label of the telephony Interface, then select the label of the Speed Dial's control.

18.6.3 Delete a speed dial

To delete a Speed Dial:

- 1) Select the **Speed Dials** link from the Configuration menu. This opens the Speed Dials configuration screen. Locate the Speed Dial you want to delete.
- 2) Click the gray button next to the description field to highlight the row.
- 3) Press **Delete**.

18.7 Key groups

Key Groups provide a way of assigning a label to keys on multiple panels in a system or within a linked set. Once the key group members have been set up using EHX, the target of the key group can be changed with a single assignment in Dynam-EC.

Up to 100 key groups can be set up on a system. Dynam-EC uses the following Key Groups:

- 4-Wire Port
- Panel Port
- Partyline
- IFB

18.7.1 Adding and deleting Key Groups

To create a Key Group and assign members to that group:

- 1) Select **Configuration > Key Groups**.

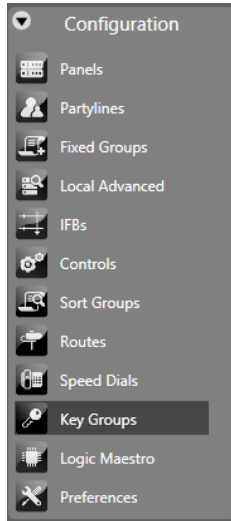

Figure 18-27 Key Groups

Talk	Listen	Description
1 KG01	KG01	Key Group 1
2 KG02	KG02	Key Group 2
3 KG03	KG03	Key Group 3

Properties

Basic Settings

Activation	Talk
Description	Key Group 1
Engineer Comments	
Listen Label	KG01
Talk Label	KG01

[Find usages](#)

Activation
Choose whether the assigned keys will be Talk, Listen, or Talk Listen.

Members

Attached:

All

#	Label	Description
	Sys 1 Port 601 ROL1 ROL1	Key 1.
	Sys 1 Port 39 223	Key 3.
	Sys 1 Port 33 217	Key 5.
	Sys 1 Port 33 217	Key 6.
	Sys 1 Port 33 217	Key 14.
	Sys 1 Port 33 217	Key 16.
	Sys 1 Port 17 219	Key 5.

Figure 18-28 Key Groups Editor

- 2) Click **New** to create a new key group and select the group to configure it using the **Properties** pane.
- 3) Change the **Label** and **Description** fields as required.
- 4) Open the **Basic Settings** menu to set up the key group properties.

To delete a Key Group:

- 1) Select **Configuration > Key Groups**. This opens the **Key Groups** configuration screen.
- 2) Select the Key Group to delete, and click **Delete**.

18.7.2 Basic options

To enable/disable basic options:

- 1) Select **Configuration > Key Groups**.
- 2) Create a Key Group or select a Key Group that was been previously created.
- 3) From the **Properties** window, expand **Basic Options**.
- 4) To edit an item in the **Basic Options** list, select the item in the left hand column and edit the text in the right hand column. You can edit the following:
 - **Activation** - determines how the assigned keys of the key group behave when the key group is activated. You can select:
 - **Talk and Listen** sets all the key group keys to talk with listen when the key group is active.
 - **Talk** sets all the key group keys to talk when the key group is active.
 - **Listen** sets all the key group keys to listen when the key group is active.
 - **Talk and Forced Listen** sets all the key group keys to talk key with permanently made listen when the key group is active.
 - **Dual Talk and Listen** sets all the key group keys to Dual talk and listen when the key group is active.
 - **Forced Listen** sets all the key group keys to Forced Listen.
 - **Description** – An optional description of the port.
 - **Engineer Comments** – An optional comment.

- **Listen Label** – A label used for identification that can be up to 10 characters long including spaces. For split labels, the maximum length is five characters.
- **Talk Label** - A label used for identification that can be up to 10 characters long including spaces. For split labels, the maximum length is five characters.

18.7.3 Key group members

The key group editor displays a list of all the panels currently assigned with the key group in the lower **Attached** pane.

Members		
Attached:		
All		
#	Label	Description
	Sys 1 Port 1	Key 10.
	Sys 1 Port 1	Key 18.

Figure 18-29 Key Group members

- 1) Drag the required key group from the palette and drop it on the required key.

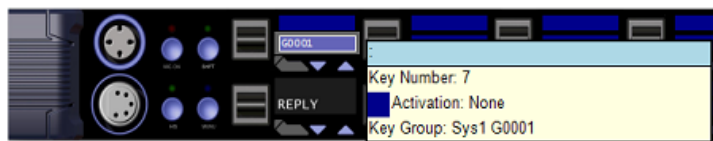

Figure 18-30 Key Group Member on Panel

- 2) Panel keys are assigned to a key group from the Panel Programming tab. Select the required panel and key then right-click to display the properties menu.



Figure 18-31 Adding a Key to a Key Group

- 3) Select **Key Groups** to display a list of all the available key groups and select the destination key group. Left click on the required key group to add the key to the key group. The assignment is indicated by the addition of a white box round the key and a checkbox against the key group.



Figure 18-32 Key Added to a Key Group

- 4) To remove a key from a key group, select the key in panel programming and right-click on it and select **Delete Key Group**.

Note: If you add or remove key group members, you might see the following message when you apply changes to the matrix:

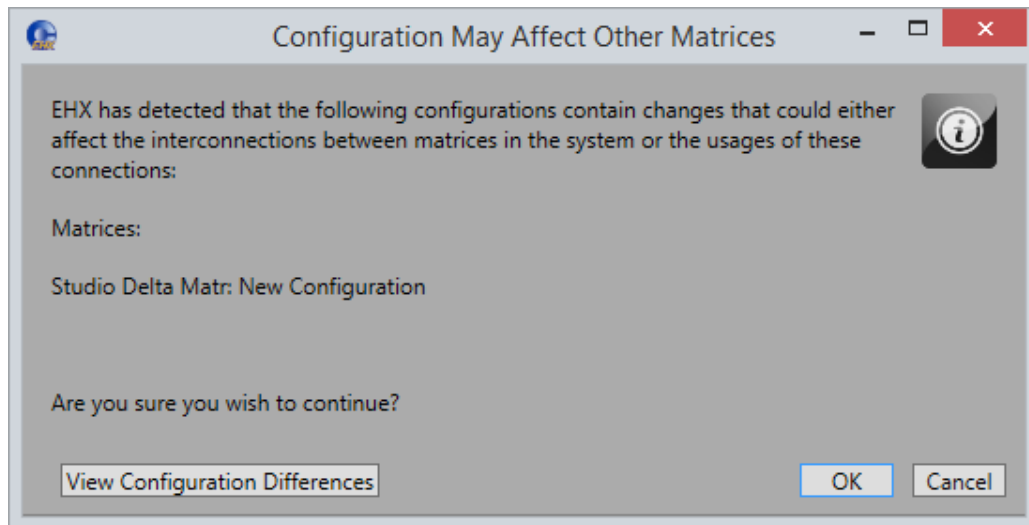

Figure 18- 18-33 Configuration may affect other matrices

Click **View Configuration Differences** to see a list of changes that affect the intercommunication between Matrices. You are advised to Apply Changes to all Matrices.

Click **OK** to continue, or **Cancel**.

Panel keys may already be assigned to destinations before being added to a key group. In this case the key functions remain active until the key group is assigned to a partyline or four-wire port by Dynam-EC, at which point the key functions are overridden by the key group destination. If the key group is deassigned by Dynam-EC the keys revert to their previous states.

Note: An **Apply Changes with reset (to initialize new hardware or add trunks)** does not delete the destination assignment of a key group, while an **Apply changes with reset and clear all memory (overwrite matrix with EHX configuration)** will delete the destination assignment of a key group.

A key group can only be introduced to the Eclipse HX working configuration by applying a configuration (key groups cannot currently be applied to a system in Go Live mode).

The EHX software only includes a configured key group in the map for a particular system if the keygroup is in use on that system. This means that in a linked set configuration, you must apply the configuration to any system that utilizes a newly created keygroup.

18.8 Logic

The Logic link on the Configuration menu opens the Logic window. Logic allows the user to create complex controls using an interactive graphic editor.

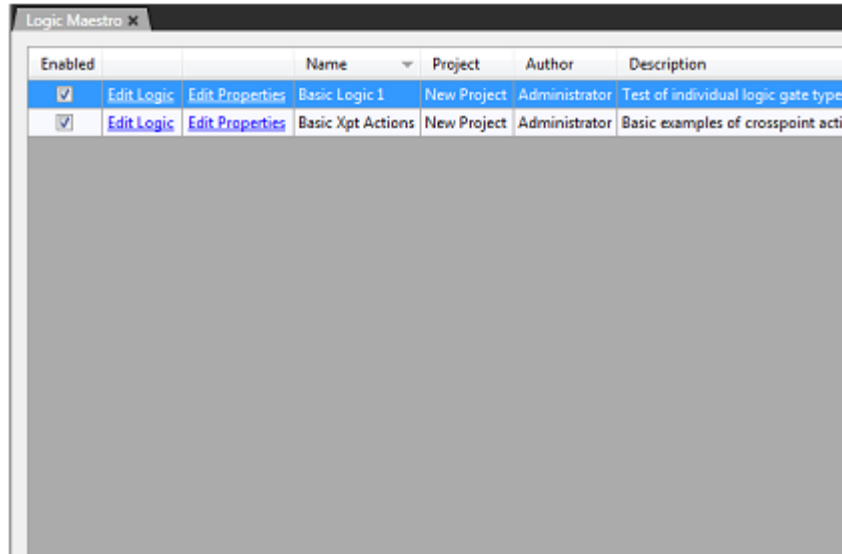

Figure 18-34 Initial Logic Screen

Logic operations are described in the *Logic Programming manual*.

19 *Virtual Interruptible Foldbacks (IFBs)*

Eclipse HX offers a new, much-enhanced architecture for interruptible foldbacks (IFBs). IFBs are now created and configured as virtual software entities

This section explains how to:

- Display IFBs
- Interpret the IFB information available within Dynam-EC
- Dynamically control and configure IFBs

These virtual entities have a number of advantages over more traditionally configured interfaces. They:

- Are easier to configure without the need for complicated cabling
- Support multiple sources, destinations and returns.
- Support multiple callers. The callers to the IFB destination, typically the talent such as a news anchor, are given a priority level from 1 – 5 (level 5 has highest priority).
- Allow members of a key group to trigger the IFBs.
- Allow monitoring of program feeds anywhere in the system without the need for patch panels. This enables troubleshooting of audio feeds.

Note: A program feed is typically a mix of audio. Listeners at different locations hear different program feeds as required.

You create IFBs in the EHX Configuration Software.

Note: An IFB allows a caller to cut or dim the audio from a configured source to a configured destination. This is typically used in broadcasts where an anchor (destination) listening to a program feed (source) can be interrupted by a director (caller). The anchor will receive audio from the director while the program feed is either dimmed or muted. If the caller priority is set to 1, the audio is mixed with the program feed.

An IFB contains the following components:

- Source – the audio that is heard by the IFB destinations while the IFB is not activated (not being called).
- Destination – where the audio is routed.
- Dim level – the extent to which the source audio is reduced.
- Caller – an audio source that triggers the IFB. The IFB destination now hears the Caller audio, and the Source audio is dimmed or muted according to the

Dim level setting. Callers are prioritized from 1 (lowest) to 5 (highest) to determine who has precedence in the feed. The default priority is 3.

- Return and Destination Listen:
 - A return listen enables the caller to hear the anchor/talent (Pre-hear).
 - A destination listen can be used to monitor program feeds and/or any active callers. The destination listen allows a caller, for example a sound engineer, to monitor the audio sent to the anchor.

Typical IFB use in a broadcasting scenario is illustrated in Figure 19-1 and Figure 19-2.

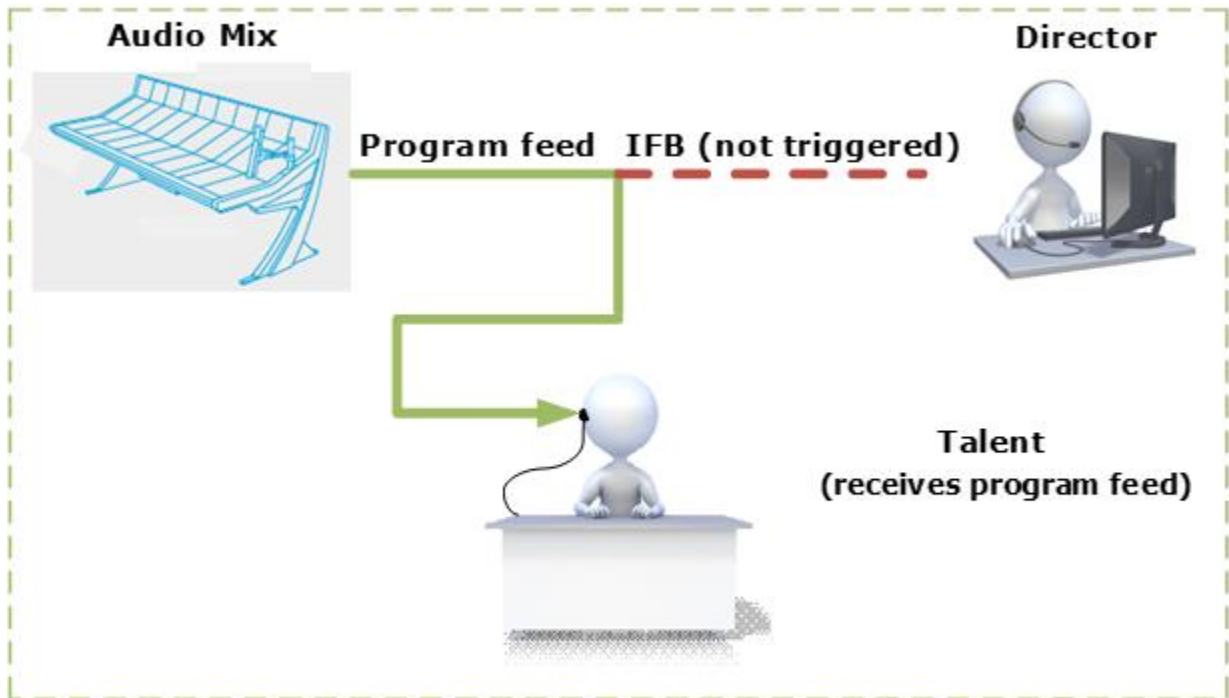

Figure 19-1 Broadcast scenario with no IFB trigger.

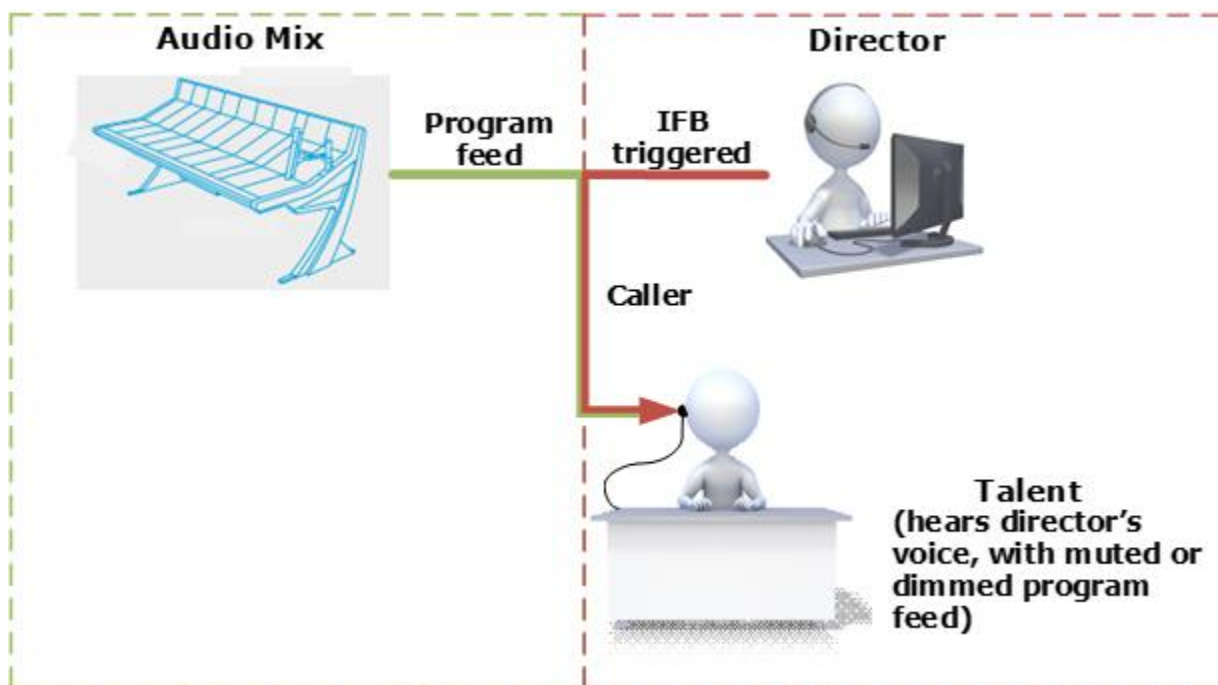

Figure 19-2 Broadcast scenario with IFB trigger

Audio mix

The program feed usually consists of a mix minus combination of audio. This means different listeners in the broadcast location are fed different audio mixes as required. Figure 19-3 shows a broadcasting application with audio mixing, where:

- **Mix minus 1** is Anchor 1 + Anchor 2 minus Remote
- **Mix minus 2** is Anchor 2 + Remote minus Anchor 1
- **Mix minus 3** is Anchor 1 + Remote minus Anchor 2

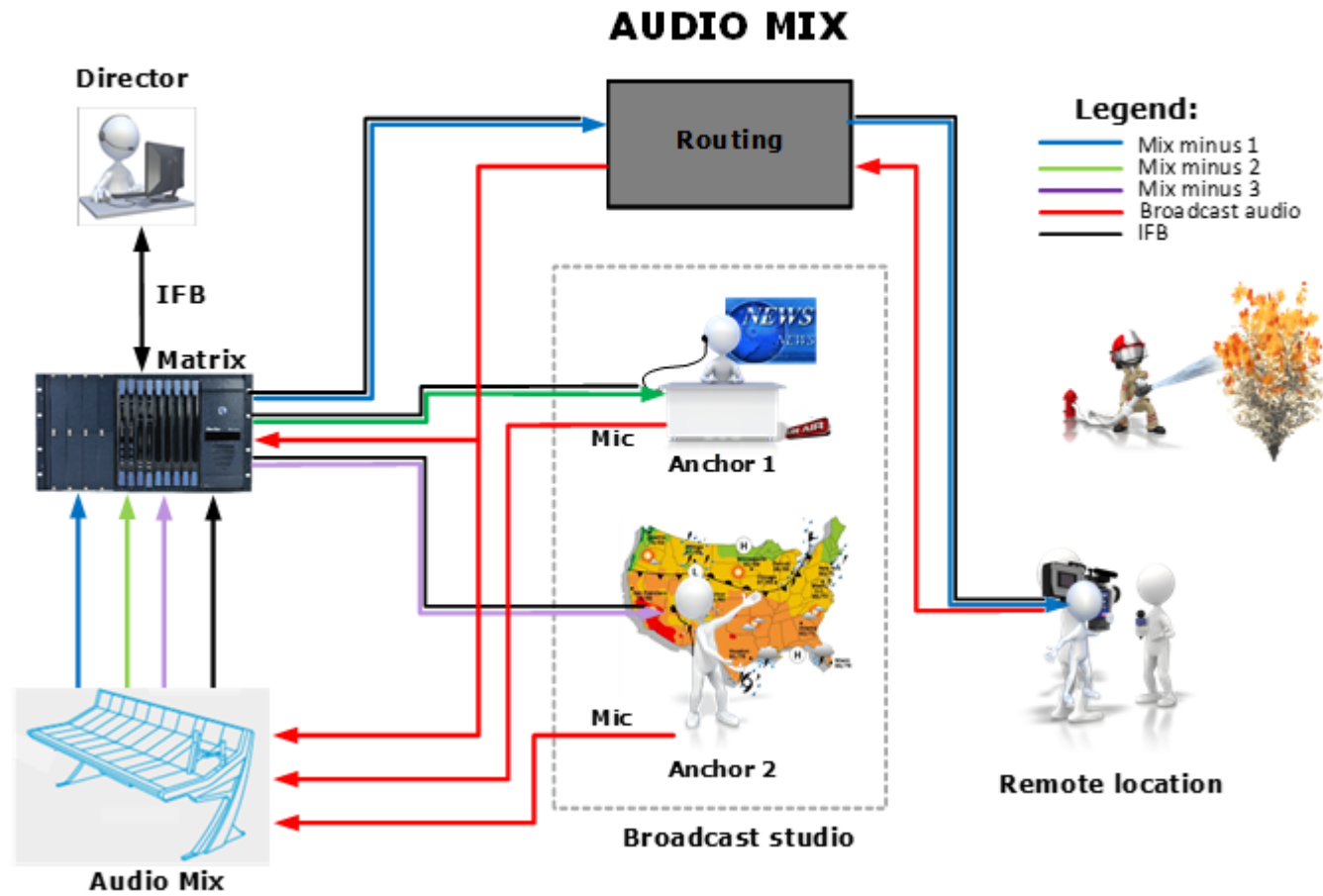

Figure 19-3 Audio mix in broadcasting application

19.1 ISO and IFB preferences

From **Configuration > Preferences > ISO and IFB** you can define how ISO and IFB operations are implemented on the Eclipse HX system.

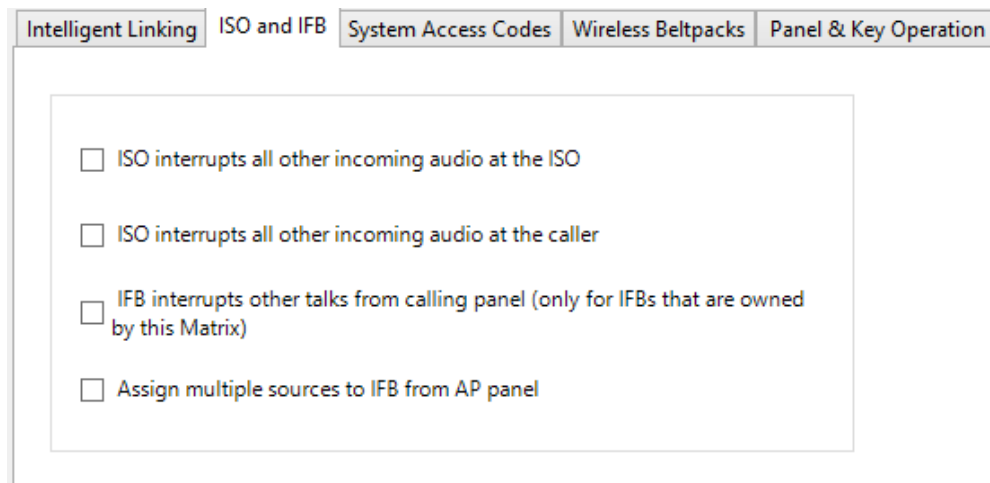

Figure 19-4 ISO and IFB tab

19.1.1 No ISO checkboxes selected (default)

If neither of the ISO checkboxes is selected, then the default ISO behavior is that when a path between the source panel and an ISO destination becomes active, then any other listen paths at the ISO source and ISO destination (CAM-3) also remain active. This enables the ISO destination to hear both the caller (Source) and the other listens during the ISO conversation.

This default behavior is shown in the example in Figure 18-5, where the Source panel is calling CAM-3.

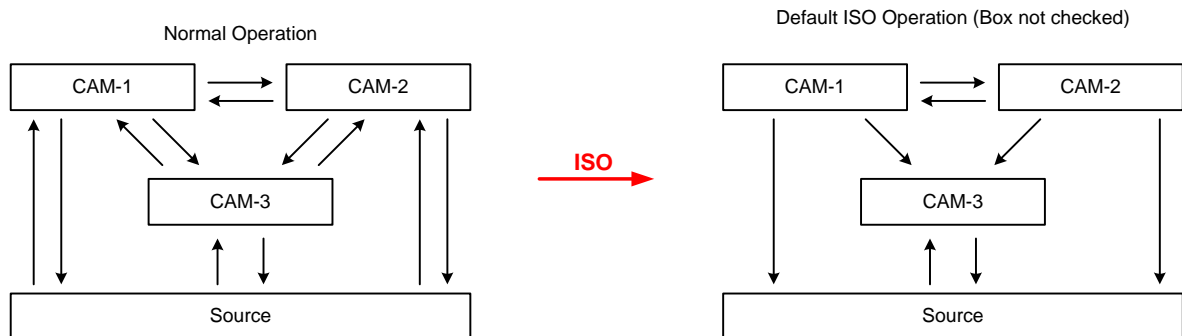

Figure 19-5 ISO Default Operation with no checkboxes selected

- The ISO destination (CAM-3) can only talk **and** listen to the ISO source (calling panel).
- The ISO destination (CAM-3) continues to hear the other listens, but talk paths are turned off for the duration of the ISO conversation.
- The ISO source continues to hear the other listens, but talk paths are turned off for the duration of the ISO conversation.

19.1.2 ISO interrupts all other incoming audio at the ISO

ISO interrupts all other incoming audio at the ISO

ISO interrupts all other incoming audio at the caller

IFB interrupts other talks from calling panel (only for IFBs that are owned by this Matrix)

Assign multiple sources to IFB from AP panel

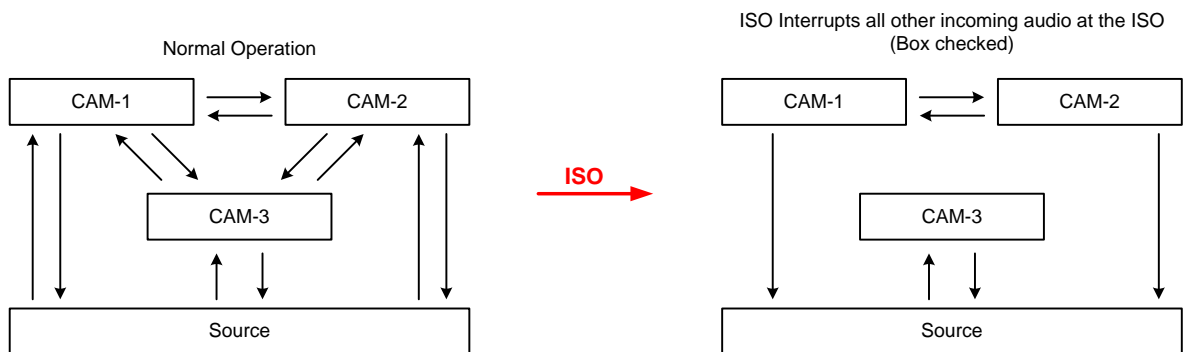

Figure 19-6 ISO interrupts all other incoming audio at the ISO

- The ISO source (calling panel) can only talk **and** listen to the ISO destination (CAM-3).
- The ISO source continues to hear the other listens, but talk paths are turned off for the duration of the ISO conversation.
- The ISO destination (CAM-3) can only talk **and** listen to the ISO Source. All other talk and listen paths are turned off.

19.1.3 ISO interrupts all other incoming audio at the caller

ISO interrupts all other incoming audio at the ISO

ISO interrupts all other incoming audio at the caller

IFB interrupts other talks from calling panel (only for IFBs that are owned by this Matrix)

Assign multiple sources to IFB from AP panel

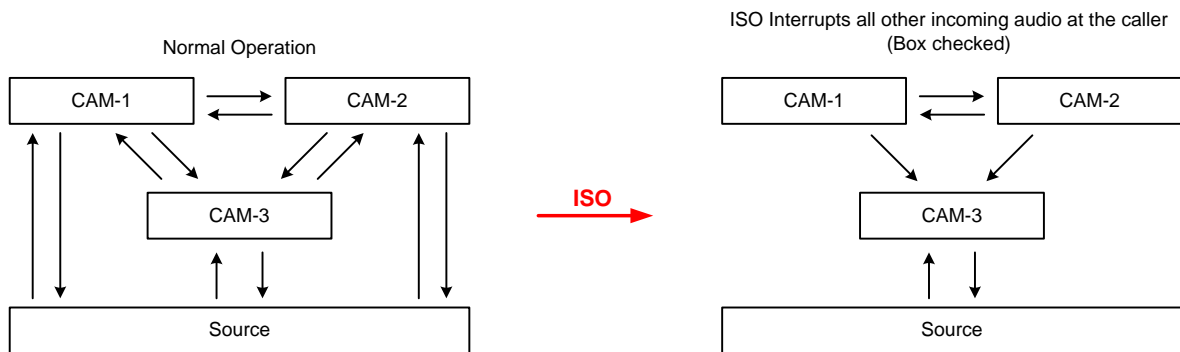

Figure 19-7 ISO interrupts all other incoming audio at the caller

- The ISO source (calling panel) can only talk **and** listen to the ISO destination (CAM-3). All other talk and listen paths are turned off.
- The ISO destination (CAM-3) continues to hear the other listens, but talk paths are turned off for the duration of the ISO conversation.

19.1.4 IFB interrupts other talks from calling panel (only for IFBs that are owned by this matrix)

ISO interrupts all other incoming audio at the ISO

ISO interrupts all other incoming audio at the caller

IFB interrupts other talks from calling panel (only for IFBs that are owned by this Matrix)

Assign multiple sources to IFB from AP panel

Figure 19-8 IFB preferences

If this checkbox is not selected (default), the default IFB behavior is that when an IFB path is active between a panel (the IFB caller) and a destination port, then none of the other talk paths are deactivated from that panel.

If the **IFB Interrupts other talks from calling panel** checkbox is selected however, all the other talk paths from the panel are interrupted (turned off) for the duration of the IFB talk.

This enables you to make a private call to a remote dialed-in IFB destination.

19.1.5 Assign multiple sources to IFB from AP panel

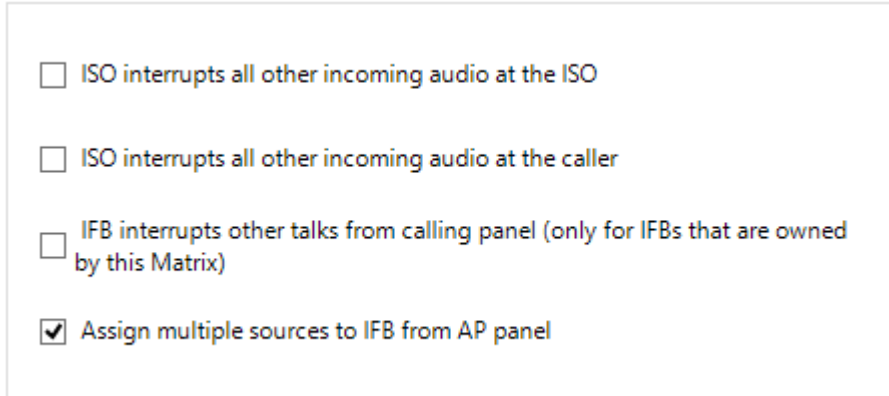

A screenshot of a configuration window showing four checkboxes. The first three are unchecked, and the fourth is checked.

- ISO interrupts all other incoming audio at the ISO
- ISO interrupts all other incoming audio at the caller
- IFB interrupts other talks from calling panel (only for IFBs that are owned by this Matrix)
- Assign multiple sources to IFB from AP panel

Figure 19-9 IFB preferences

If you select this checkbox, an AP panel can assign multiple sources to an IFB destination. The IFB hears all the incoming audio from the selected sources.

19.2 Viewing and creating virtual IFBs

To view or create IFBs, select **Configuration > IFB**.

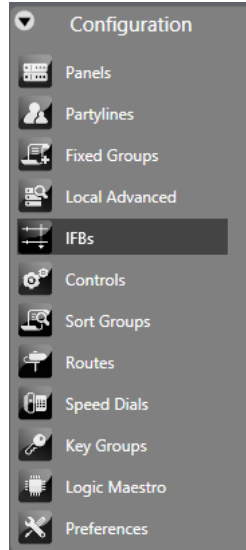

Figure 19-10 IFBs

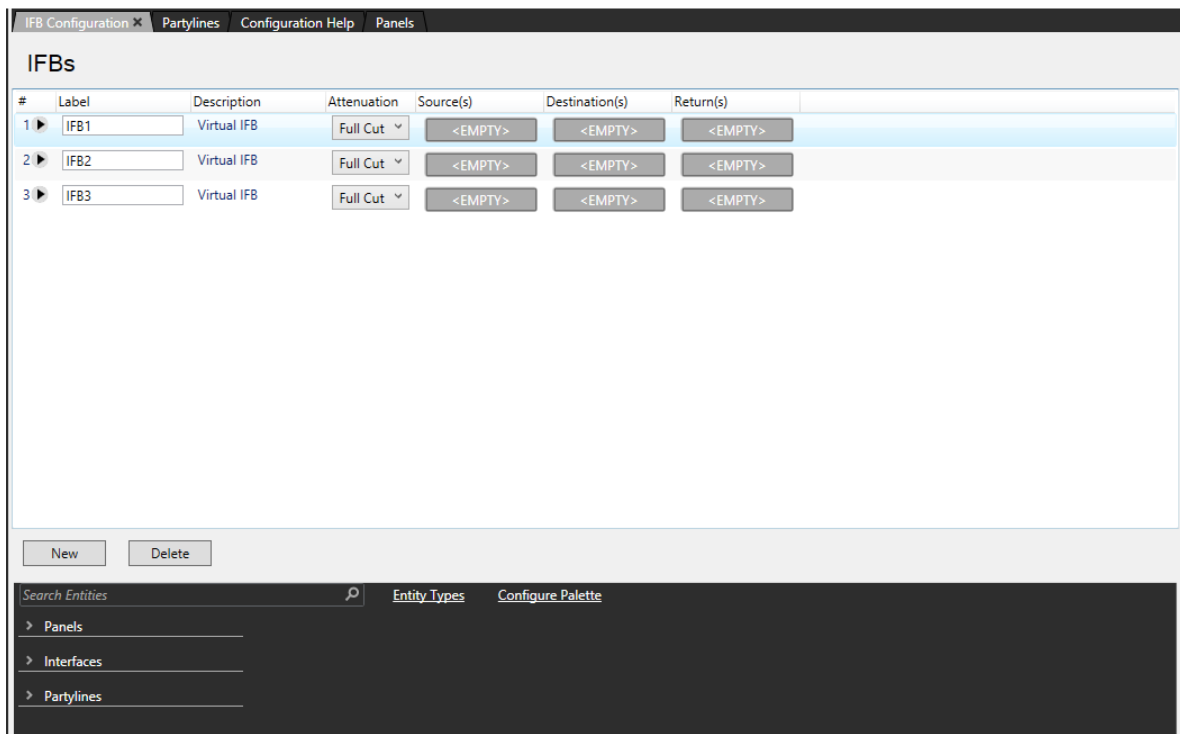

Figure 19-11 The IFB screen

Any IFBs already configured in the system are displayed in a grid with the following information:

Label – a name for the IFB. To change the label, click the **Label** field and type a new label.

Description – a summary of the IFB function. To change the description, click the **Description** field and type a new description.

Attenuation – the level by which the source audio is dimmed. This ranges from No Cut to Full Cut in 3 dB increments. To change the attenuation, click the drop-down arrow and select a new value.

Source – the IFB source.

Destination – the IFB destination.

Return – the IFB return.

You can change sources, destinations and returns by using the mouse to drag an entity from the pallet below the IFB grid onto the required source, destination or return field.

Select IFB List Options to display:

- **Show/Hide ALT Text** – Displays ALT text labels.
- **Auto Returns Enabled/Disabled** – When enabled, automatically adds or removes IFB returns when IFB destinations are added or removed.

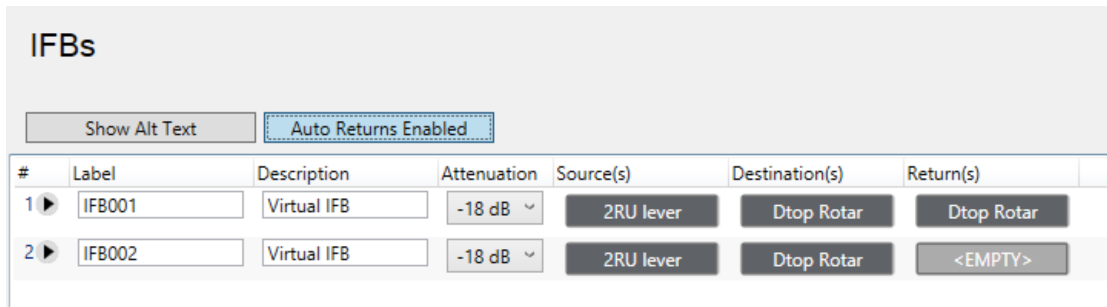

Figure 19-12 IFB screen showing list options

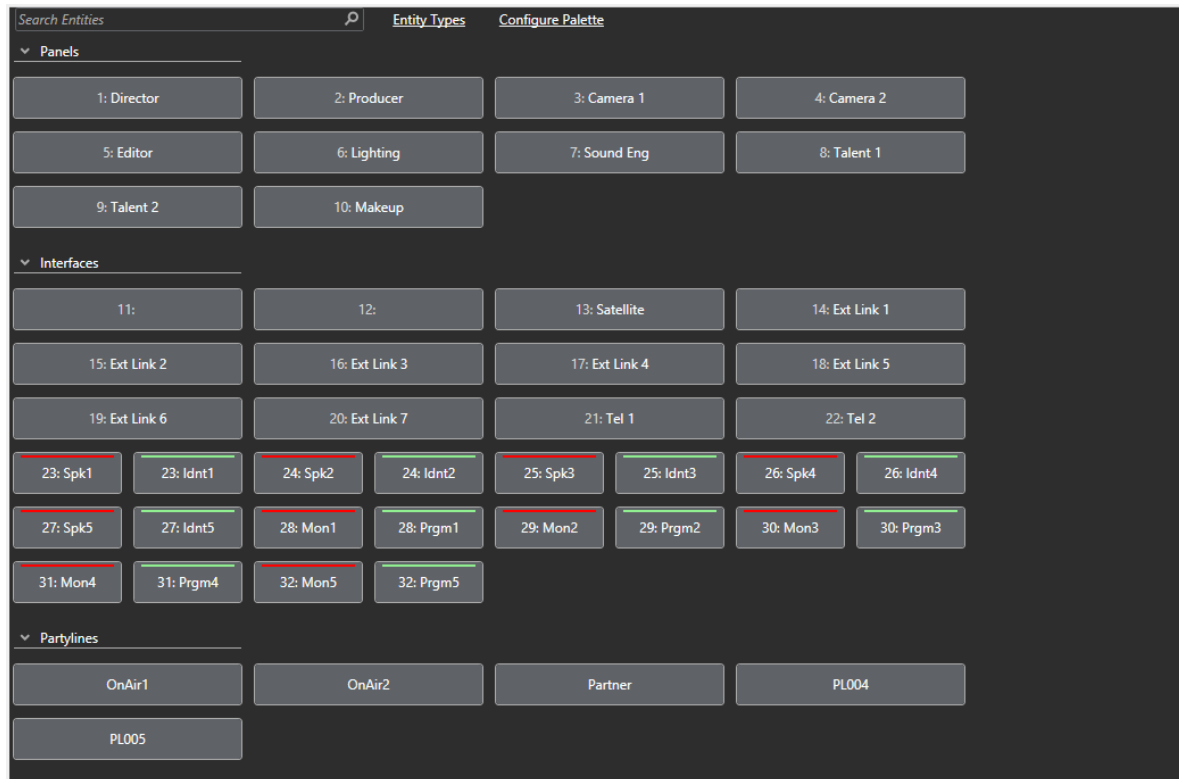

Figure 19-13 IFB pallet

To remove an item from the source, destination or return field, right-click the field and select **Remove Item**.

Note: If you add a port to the destination field, it is automatically added to the return field (if auto-returns is enabled).

You can have a maximum of six sources, destination and return for each IFB.

Note: Sources, destinations and returns can be on a remote matrix. If a panel has keys to remote returns or destinations, their input and output levels can only be adjusted from the return/destination local matrix frame. They cannot be adjusted on the panel.

Note: Remote sources and returns will be permanently routed to the IFB host frame. Therefore, to reduce intelligent linking resources, the IFB should be created on the same matrix frame as the destinations and or returns if possible.

To add multiple sources, destinations or return:

- 1) Select the arrow to the left of the IFB label.
- 2) Drag the extra source, destination or return onto the **ADD +** button.

19.3 Configuring IFB properties

To configure IFB properties:

In the **IFB** screen, select the required IFB.

Note: You can use the **Ctrl** key to select more than one IFB.

The Properties screen appears on the right hand side of the window.

19.3.1 Global properties

You can configure the following global properties:

IFB Number – This uniquely identifies the IFB.

Auto Listen – Any port that talks to the IFB destination port automatically hears the IFB return audio.

Latch Disable – Disables key latching so that keys are only active while they are held down or pressed. The default is for disabled key latching.

IFB Attenuation – Sets the dim level of the IFB from no cut to full cut in steps of 3dB.

19.3.2 Basic options

You can configure the following basic options:

Alias (Remote Matrix) – Defines an alias for an entity on a remote matrix. The alias can have up to 10 characters including spaces.

Note: This feature is only available if **Freely Editable** is selected in **Configuration > Preferences > Alias Labels**.

Alt Text – Defines the text that appears when the **ALT TEXT** key is pressed.

Comments – Use this field to enter a comment about the port and its use.

Description – Use this field to enter a description of the field.

Dial Code – Defines the dial code used in fast key assign operations.

Label -Defines the identity label. This can have up to 10 characters including spaces.

19.3.3 Fast key assign options

You can configure the following fast key assign options:

Enable Assignment as Listen – The IFB can be locally assigned to a listen key on another panel.

Enable Assignment as Talk – The IFB can be locally assigned to a talk key on another panel.

Default Assign as Talk and Forced Listen – If the IFB is locally assigned to a key on another panel, the default is talk and forced listen.

Protect Port from Assignment – Prevents a panel user from changing the default attributes of the key, for example changing a listen key to a talk key.

Note: This is only available if Enable Assignment as Talk and Enable Assignment as Listen have different values.

19.3.4 Tally options

In Use Tally – The panel tally light flashes when another panel or entity talks to the IFB port. The default is ON.

Note: You can configure tally options in **Configuration > Preferences > Panel & Key Operation**.

19.3.5 Attached control options

Secondary Action – When a talk to the IFB is activated, the IFB is triggered along with the associated control.

20 Adding and configuring wireless devices

This chapter describes how to add and configure FreeSpeak IP Transceivers and beltacks to use with the FreeSpeak wireless partyline system. For more information, see the relevant CellCom/FreeSpeak or FreeSpeak II User Guides.

20.1 CellCom/FreeSpeak Beltacks

To add and configure beltacks, use the beltack configuration editor.

Note: The beltack configuration editor is only available if an E-Que antenna or E-Que splitter card has been configured in the matrix.

Note: Before you can use a beltack, it must first be registered to the system.

- 1) Select **Hardware > Cards and Ports**, and then add an E-Que Antenna or E-Que Splitter card.
- 2) From **Configuration > Preferences > Wireless Beltacks**, set the correct DECT system ID and Frequency.
- 3) From **Tools > Matrix Connection**, configure the COM port to use for the beltacks.
- 4) Select **Hardware > Beltacks**, and register a beltack.
- 5) Connect the required beltack on the COM port.
- 6) Click **Register connected Beltack to this system**.
- 7) Click the **Register Beltacks** button to register a beltack. A list of instructions to register a beltack is displayed.
- 8) When the beltack is powered up and connected click **Register**. A confirmation screen is displayed when the beltack has been registered. If the beltack cannot be registered an error message is displayed.

Note: The Associated Role field can be edited by positioning the cursor in the box and editing the text.
A description of the beltack can be added in the **Description** column.

20.1.1 Beltack properties

To edit Basic Options:

- 1) Select **Hardware > Beltacks**.

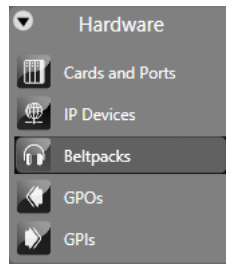

Figure 20-1 Beltpacks

- 2) Select the required Beltpack Role.
- 3) From the **Properties** window, expand **Basic Options**. You can edit the following:
 - **Associated role** - Select a role from the list of available beltpack roles set up using the Beltpack Roles facility. See section **20.1.2 Adding and deleting beltpack roles**.
 - **Description** - Enter an optional description for the beltpack such as user or department.
 - **Comments** - An optional comment.
 - **Listen Label** - The Listen label that is available for panel configuration (a combined Talk/Listen label is shown unless the option for 10 character labels is turned off).
 - **Power up state** - This defines whether the beltpack role is set to a preferred role or a fixed role when it is powered up. For more information, see the CellCom/FreeSpeak User Guide.
 - **Serial Number** - The beltpack serial number. This field is non-editable.
 - **Talk Label** - The Talk label specified for use in the panel configuration table (a combined Talk/Listen label is shown unless the option for 10 character labels is turned off).

20.1.2 Adding and deleting beltpack roles

Beltpack roles define the beltpack in the same way as a label defines a key on a panel so that assigning a role to a beltpack has the effect of creating a label for it that can be referenced by other devices in the system such as a panel.

Note: The **Beltpack Roles** screen is only available if an E-Que antenna or E-Que splitter card has been configured in the matrix.

- 1) Select **Configuration > Beltpack Roles** to display the beltpack roles editor.

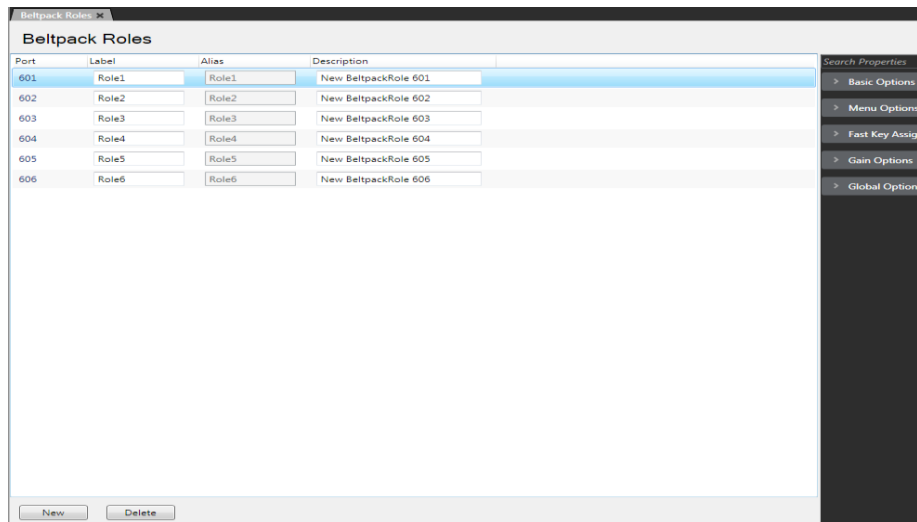

Figure 20-2 Beltpack Role Editor

- 2) To create a new beltpack role, select **New**.
- 3) Change the **Label** and **Description** fields as required.

Highlighting the role allows the role properties to be entered using the **Properties** window.

To delete Beltpack Roles:

- 1) Select **Configuration > Beltpack Roles**. This opens the **Beltpack Roles** configuration screen.
- 2) Select the role to delete, and click **Delete**.

Beltpack Role Basic options

To edit Basic Options:

- 1) Select **Configuration > Beltpack Roles**.
- 2) Create a Beltpack Role or select a previously created Beltpack Role.
- 3) From the **Properties** window, expand **Basic Options**. You can edit the following:
 - **Alias (Remote Matrix)** - Use this option to allow labels to appear differently on remote systems compared to the local system. The maximum number of characters including spaces is 10.
 - **Alt Text** - Alternative text that is shown when the ALT TEXT special key is activated.
 - **Comments** – An optional comment.
 - **Description** - Enter an optional description for the beltpack role such as user or department.

- **Dial Code** – This is used for Fast Key Assign operations on a panel.
- **Label** – A 10-character label that is available for panel configuration.

Beltpack Role Menu options

These options determine the level of access that users have to menus. To edit the Menu options:

- 1) Select **Configuration > Beltpack Roles**.
- 2) Create a Beltpack Role or select a previously created Beltpack Role.
- 3) From the **Properties** window, expand **Menu Options**. You can select the following:
 - **Advanced** - Full access to all menu options and settings.
 - **Normal** - Beltpack microphone type and headphone limiter setting are locked, but all other options and settings are available
 - **Basic** – All beltpack options and settings are locked except contrast, master volume, key lock, tap latch, page lock and information screens.
 - **None** - All menus and settings are locked and cannot be viewed.

Beltpack Role Global options

To edit the Global options:

- 1) Select **Configuration > Beltpack Roles**.
- 2) Create a Beltpack Role or select a previously created Beltpack Role.
- 3) From the **Properties** window, expand **Global Options**. You can select the following:
 - **IFB Caller Priority** – The priority of the port when it is used as caller in an IFB. Sources and other callers with lower priorities will be dimmed. When the port is used as an IFB source, its priority is always 1.
 - **IFB** – Makes the port an IFB destination. IFB sources are configured on **Configuration > IFBs** or **Configuration > Local Advanced**. See also **Configuration > Preferences > ISO and IFB** where you can enable the following settings:
 - IFB interrupts other talks from source panel.
 - Assign multiple sources to IFB from AP panel.
 - **IFB Attenuation** – When a port talks to the IFB destination port, IFB sources are automatically dimmed by the IFB attenuation setting.

- **Latch Disable** – Disables key latching on all callers to this port. Keys remain active only while they are held down or pressed.

Fast Key Assign options

To edit the Fast Key Assign options:

- 1) Select **Configuration > Beltpack Roles**.
- 2) Create a Beltpack Role or select a previously created Beltpack Role.
- 3) From the **Properties** window, expand **Fast Key Assign Options**. You can select the following:
 - **Enable Assignment as Listen** – Allows the port to be assigned locally using Local Key Assign/Fast Key Assign as a listen key by another panel.
 - **Enable Assignment as Talk** – Allows the port to be assigned locally using Local Key Assign/Fast Key Assign as talk key by another panel.
 - **Default Assignment as Talk and Forced Listen** – the default for a key assigned to this label is Talk and Forced Listen.
 - **Protect Port from Assignment** – Prevents this port from being locally assigned by another panel in Local Key Assign mode.

Gain options

To edit the Gain options:

- 1) Select **Configuration > Beltpack Roles**.
- 2) Create a Beltpack Role or select a previously created Beltpack Role.
- 3) From the **Properties** window, expand **Gain Options**. You can select the following:
 - **Input Gain** – Sets the level of gain on the matrix input to the port (default 0dB).
 - **Output Gain** – Sets the level of gain on the matrix output to the port (default 0dB).

20.1.3 Beltpack programming

Beltpack programming (assigning labels to keys, setting beltpack operating parameters and so on) is carried out in Panel Programming treating the beltpack as a panel where labels can be dragged and dropped onto keys in the same way as panels.

To program a beltpack select **Configuration > Panels** and select the required beltpack from the drop-down list of panels at the top of the window. The beltpack mimic is displayed.

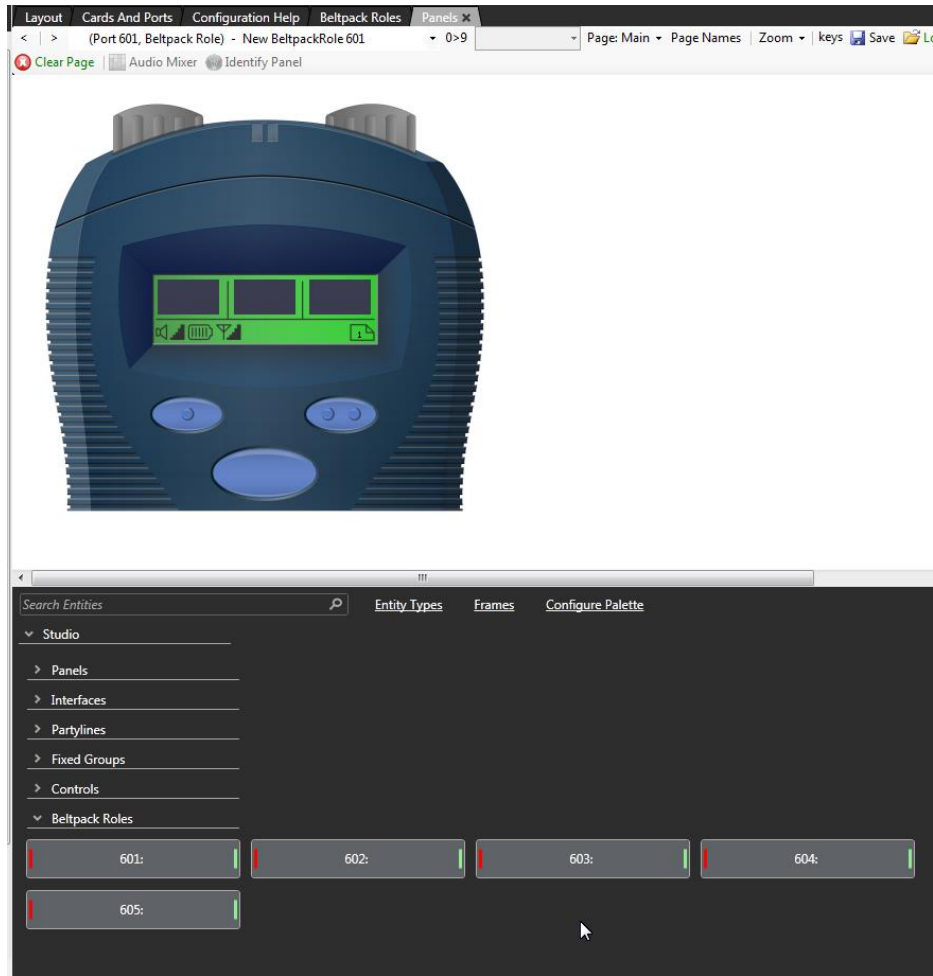

Figure 20-3 Beltpack Programming Screen

Labels can be selected from the list and dragged and dropped onto beltpack keys.

Six pages of keys are available on the beltpacks. The key pages are selected from the drop-down **Page** list. The pages are Main (the default page), Shift1, Shift2, Shift3, Shift4 and Shift5.

When the pointer is placed over a key the status of the key is displayed showing the beltpack role, key number and the key type.

Right clicking a key opens a key configuration menu allowing the key type, local assignment, interlock group and latch disable to be set up.

Activation

The activation option allows the key type to be configured to determine how the key behaves when activated via the encoder.

- 1) To set the key activation type right click over the required key to display the options menu and then select the **Activation** item to display the activation options.

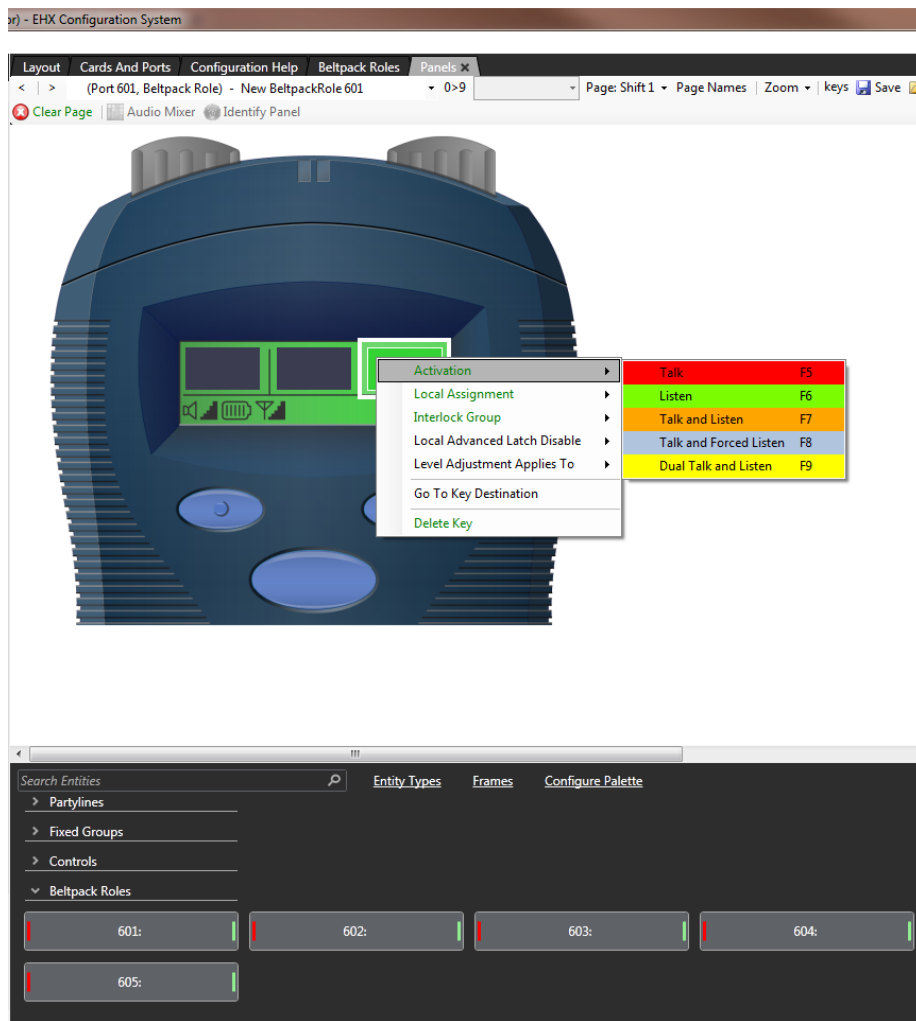

Figure 20-4 Beltpack Key Assignment Menu

The activation options are: Talk, Listen, Talk and Listen, Talk and Forced Listen or Dual Talk and Listen.

- Talk sets a talk from the beltpack to a destination with no automatic listen to the destination.
- Listen sets a key to listen to the source without talking to the destination at the same time. Use as a monitor key (turn the encoder clockwise or counter clockwise to adjust the volume).
- Talk and Listen sets a talk key with listen (turn the encoder clockwise or counter clockwise to adjust the volume).
- Talk and Forced Listen sets a talk key with permanently made listen (turn the encoder clockwise or counter clockwise to adjust the volume).
- Dual talk and Listen. This makes the pushbutton activate a Talk and Listen on a press and hold, or latch a Listen with a short press and release (less than 200ms) on the same pushbutton.

Local assignment

Click on the Local Assignment entry to display the available options for local key assignment. The options are to allow local key assignment and to disallow local key

assignment. If the local assignment is allowed for the key then the beltpack key can be locally assigned by entering the beltpack menu Key Assign option.

Interlock group

The EHX user can assign several keys on a beltpack into a selector group and restrict the group so that only one key of the group can be activated at any one time. This function only refers to talk paths.

Note: For example, if a beltpack had three keys programmed to talk to cameras 1 to 3 then by setting these into an interlocked group only one camera key can be selected at a time.

There are nine available interlocked groups to which the EHX user can assign any or all beltpack keys.

To add a key to an interlocked group

- 1) From Panel Programming, select the beltpack.
- 2) Right click on the required key to display the key options list.
- 3) Select the **Interlock Group** entry to display the interlock group options list.
- 4) Select the required interlock group or **None** if the key is not to be in any interlock group.
- 5) The key may be added to other interlock groups as required.
- 6) The key interlock groups are displayed in the key information popup.

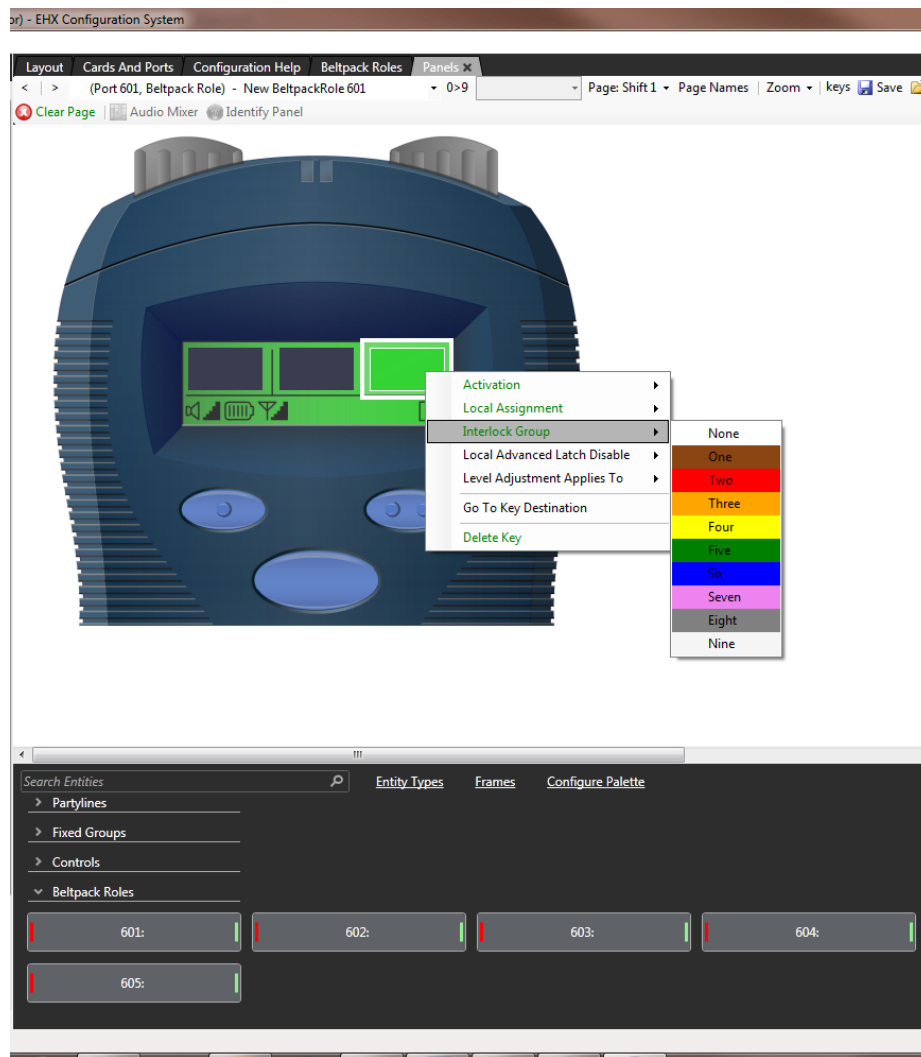

Figure 20-5 Beltpack Interlock Group Assignment

Local advanced latch disable

This allows latching of keys to be disabled locally on the belt pack. It may be set to On or Off.

Level adjustment applies To

This determines whether local adjustment applies to crosspoints, inputs or outputs.

Go to key destination

Click the **Go To Key Destination** entry to display the Matrix Hardware editor screen with the destination the key refers to highlighted.

Delete key

Click the **Delete Key** entry in the menu to delete the assigned label (shown highlighted). Note that only the highlighted label is deleted. The green listen label for that key is not deleted.

20.2 FreeSpeak II® (FS II) beltpacks

20.2.1 Registering beltpacks

Before a beltpack works, it must be registered to the system. There are two ways to do this:

- By using a USB connection between the beltpack and the computer hosting the EHX software
- By using Over The Air (OTA) registration.

Registering beltpacks using a USB cable

- 1) Select **Hardware > Cards and Ports**, and then add an E-Que FS II-TA Antenna or an E-Que FS II-TA Splitter card.
- 2) Turn the beltpack on.
- 3) Connect the beltpack to a USB port on the computer.
- 4) From the **Hardware** menu, select **Beltpacks**.
- 5) Click **Register Beltpack**. The following screen appears containing a list of instructions.

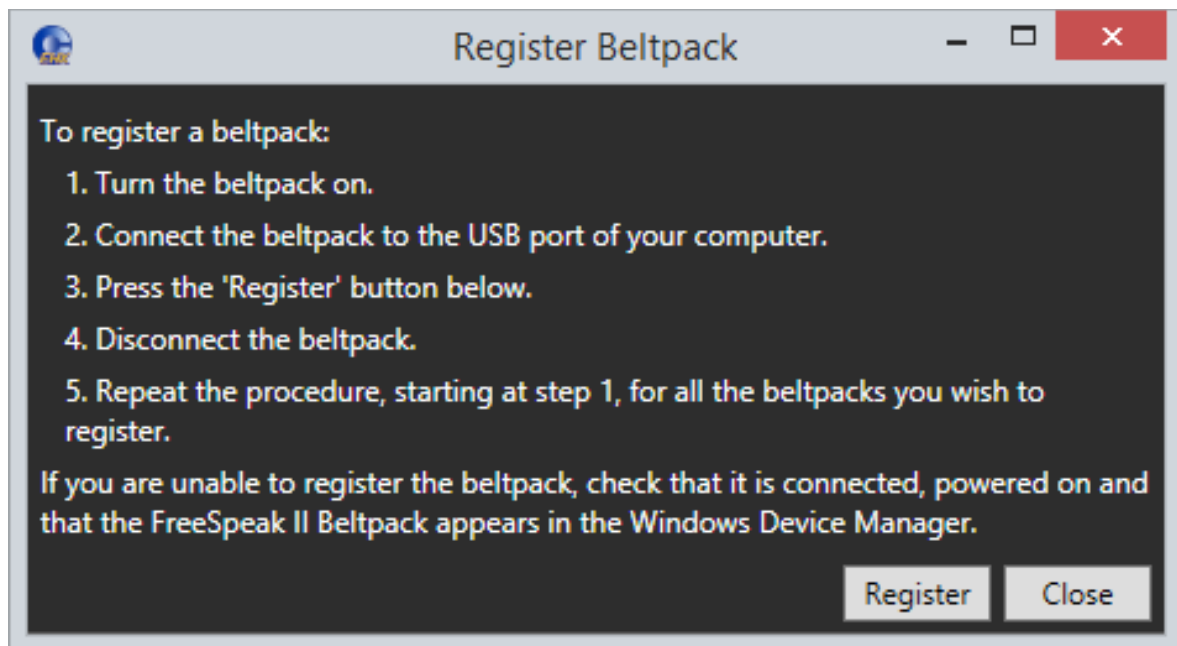

Figure 20-6 Register beltpack

- 6) Click **Register**.

Registering beltpacks over the air

Over the Air (OTA) must be enabled before you can register a beltpack over the air.

You can do this either from the EHX software or from a beltpack that is already registered and has basic menu access or higher with the required admin code. For

information about enabling OTA registration from a beltpack, see the **FreeSpeak II User Manual, 8.13 Enabling OTA registration from a beltpack.**

To enable OTA from the EHX software:

- 1) From the **Hardware** menu, select **Beltpacks**.

Note: Beltpacks can be registered before they have a role. However, until they have a role assigned to them they cannot be logged in to the system. So it is a good idea to have roles for beltpacks assigned before registration. You may wish to register more beltpacks than you have roles for, to allow for spare beltpacks. See section **5.59.4** below for more information on assigning beltpack roles.

- 2) Click **Enable Registration Mode**.

This opens registration or pairing mode for two minutes.

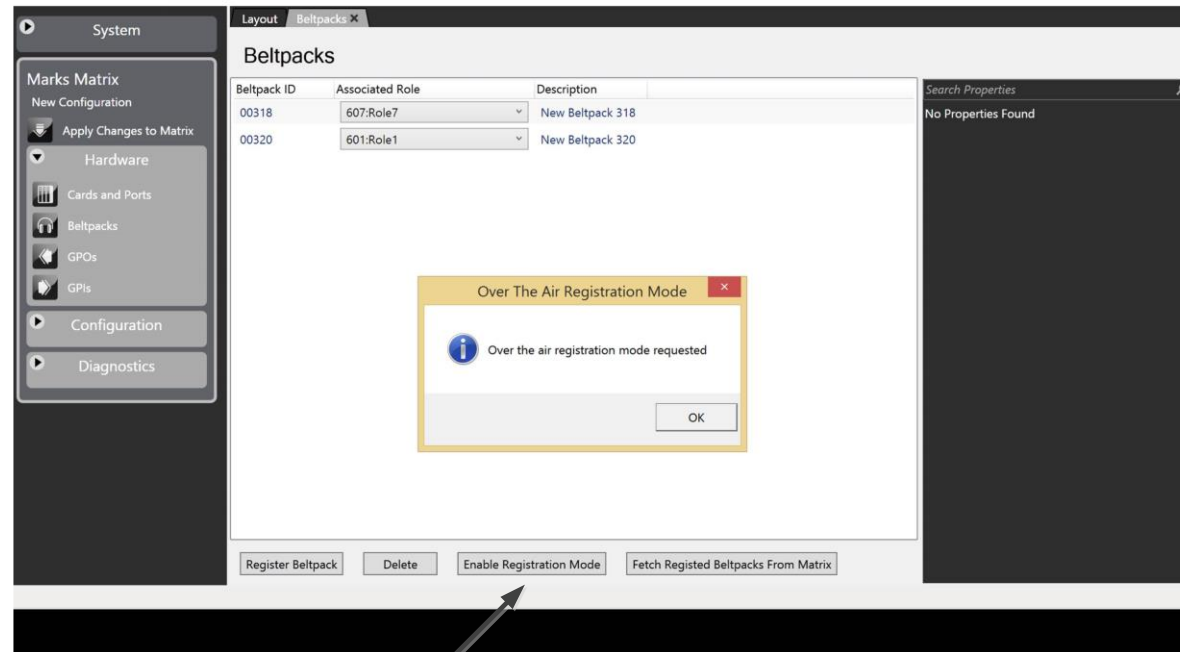

Click here to enable over the air registration

Figure 20-7 Enable over the air registration requested.

- 1) Once OTA registration is enabled it will be necessary to follow the OTA registration sequence from the beltpack to be registered.

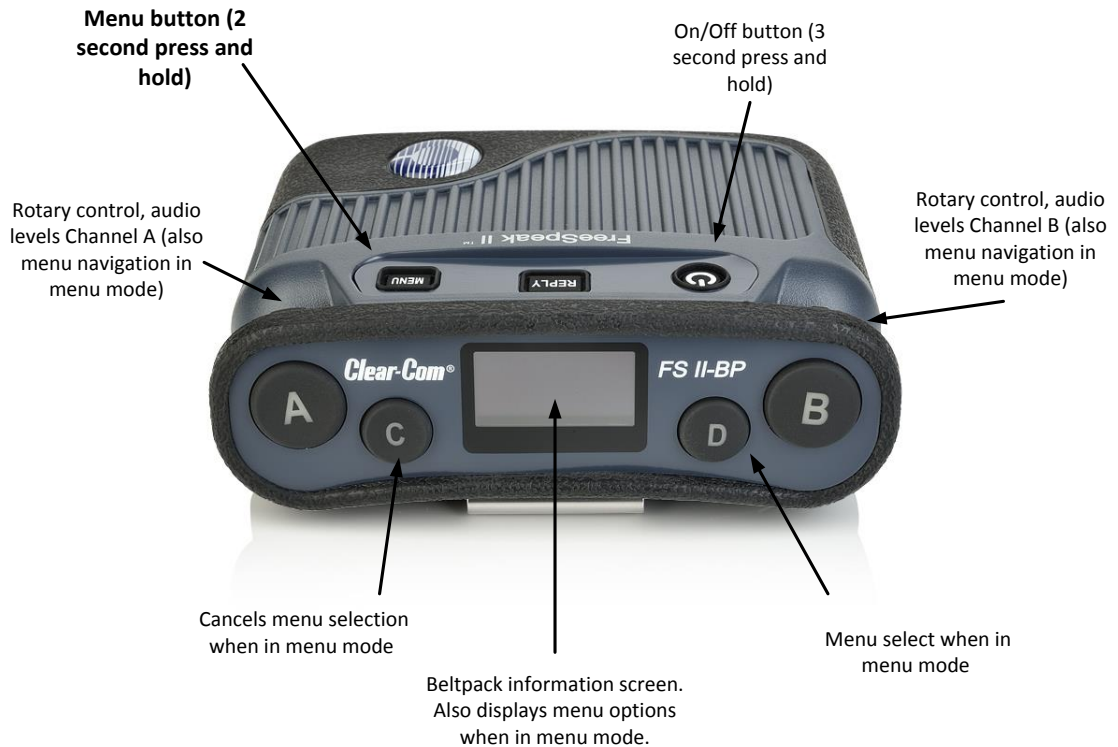

Figure 20-8 Beltpack menu controls

- 2) Power on the beltpack.
- 3) On the beltpack to be registered, hold the **menu** key for two seconds to enter MENU options. Scroll to SYSTEM CONNECT using the rotary controllers and select it using key D. In menu mode the D key on the beltpack operates as SELECT and the C key exits the menu level and cancels the selection.

Note: On a new system there will be no previous connections at this point. However, if the beltpack has been connected previously, a confirmation screen will appear. Select **Yes** to connect to a new system or **No** to remain connected to the current system.

- 4) Available systems will be visible on the beltpack menu screen.

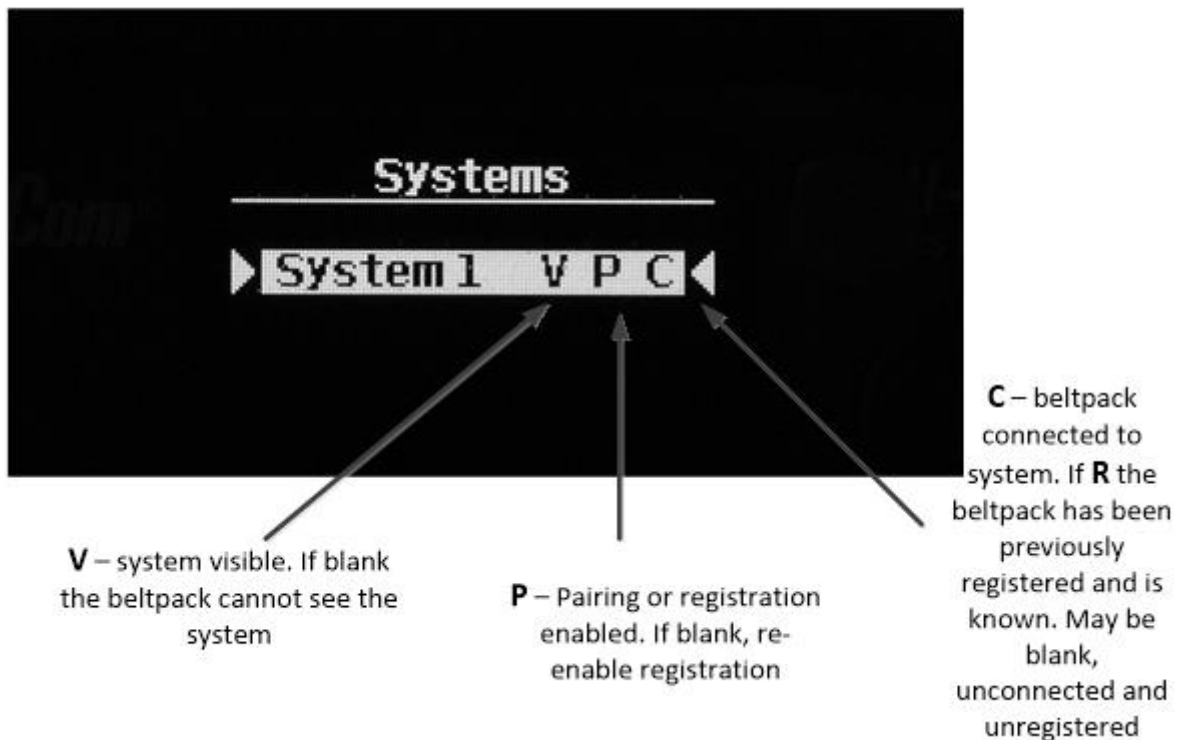

Figure 20-9 Beltpack systems information screen

To connect the beltpack to the system, the system must be

- Visible (**V**) and
- In registration (pairing) mode (**P**) on the beltpack screen.

If the system is not in registration mode (P is not visible), registration should be re-enabled on the matrix using the EHX screen.

Note: If a beltpack is connected to a system, 'C' will be visible in this screen. If a beltpack is not currently connected but has been in the past, 'R' will be visible. This shows that the beltpack has been previously registered with the system which will recognize it.

- 5) Scroll to the system you want and press **D** (menu select) on the beltpack.
- 6) You will be presented with a PIN code screen. Enter the four digit pairing code for the system using both rotary controllers and the menu select key (**D**). The default code is 0000. Use the right hand controller (A) to scroll through numbers 0-9 and the left hand controller (B) to move through the square number boxes.

Note: To change the OTA registration pin code, go to: **Configuration > Preferences > Wireless Beltpacks.**

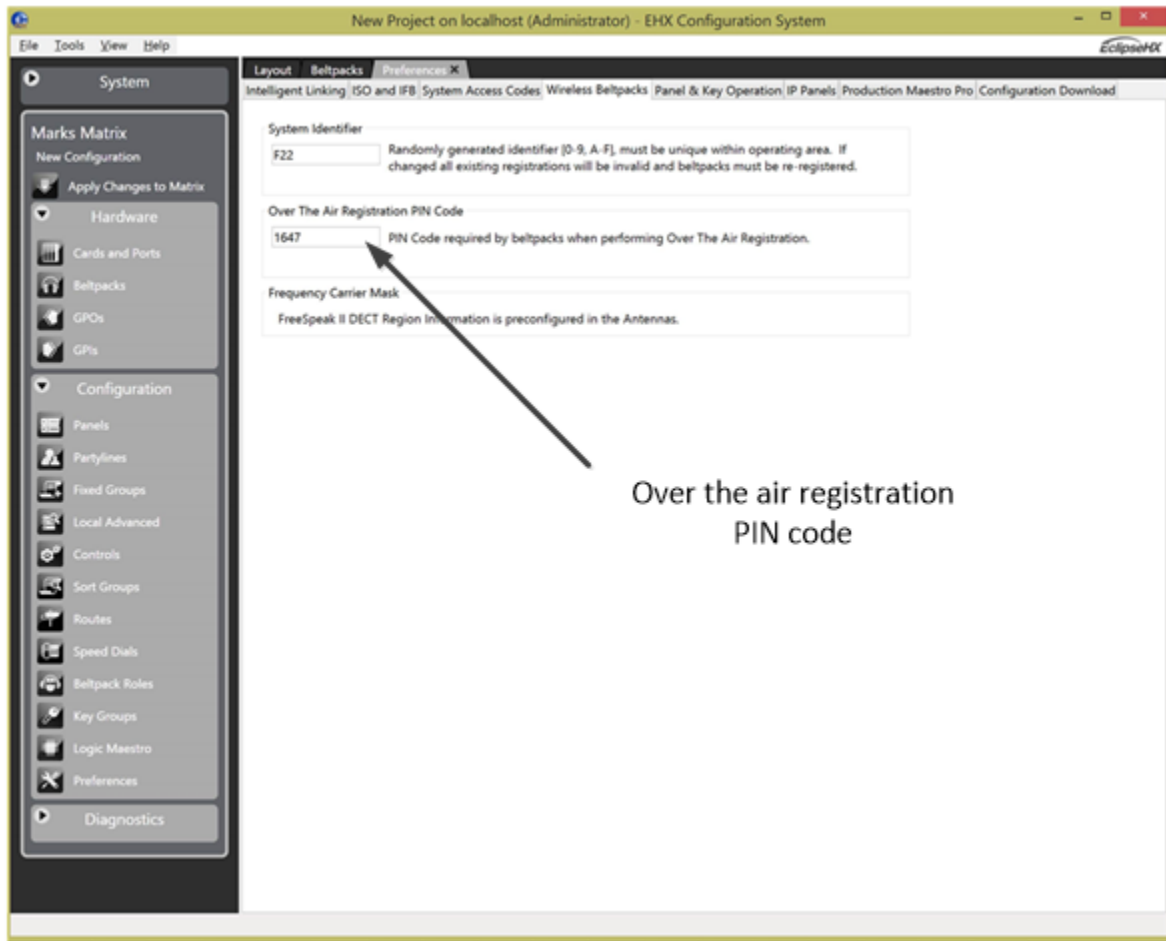

Figure 20-10 OTA registration PIN code

- 7) After entering the correct pairing code on the beltpack screen, select D, and then select an available role from the list displayed.
- 8) The beltpack is now registered and ready for operation.
- 9) If required, the next beltpack can now be registered (Step 2).

20.2.2 Fetching registered beltpacks

Beltpacks registered over the air are not saved in the PC copy of the configuration map until they are fetched.

There are two situations where beltpacks do not need to be added to the configuration map:

- When the beltpack is for temporary use.
- When the beltpack is already in the configuration map (previously registered and fetched).

Note: If OTA mode is initiated by EHX, not a beltpack, EHX will automatically fetch the list of beltpacks registered to the matrix that are not in the locally stored map. The user is presented with the option to add these to the map stored in EHX, to apply later.

To add the beltpack to the configuration map (fetch beltpack):

- 1) From the **Hardware** menu, select **Beltpacks**.
- 2) Click **Fetch Registered Beltpacks From Matrix**.

Note: If beltpacks registered by OTA are not fetched and stored in the PC configuration file, the next apply will not include these beltpacks and they will appear as unregistered.

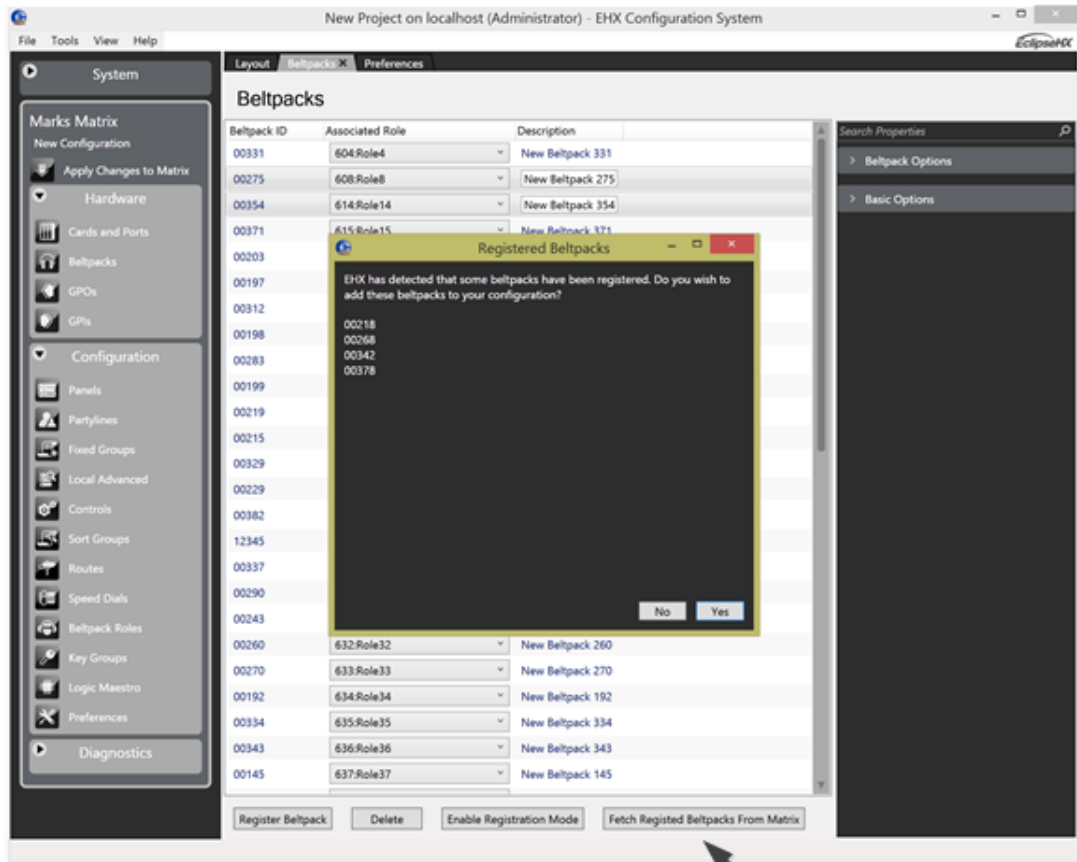

Fetch beltpacks to add them to configuration

Figure 20-11 Fetch registered beltpacks

The EHX system will remind you to fetch registered beltpacks if this has not already been done.

20.2.3 Control audio on beltpack keys C & D using rotary controllers

Giving the **menu** button on a beltpack a quick tap can trigger Listen Again, as described in the FreeSpeak User manuals (FreeSpeak Base and FreeSpeak II Integra, section 8.9). However, a quick tap on the **menu** button can also be configured to allow volume on beltpack keys C & D to be adjusted by the rotary controllers, instead of triggering Listen Again. The menu key can be configured to toggle between level controls for A & B/C & D.

The default setting for this key is **Listen Again**.

Note: This mode has a 5 second inactive time-out, after which time the rotary controllers will revert to controlling volume on keys A & B. To re-activate this mode in order to adjust C & D, use another quick tap of the menu key. To switch quickly between A & B and C & D, tap the menu key to toggle.

How to set beltpack **menu** key behavior in EHX software:

- 1) From the EHX software configuration editor, navigate to **Configuration/Beltpack Roles/Beltpack Role/Menu Options/Menu Key Operation**
- 2) From the dropdown list, select **Switch Encoders**.

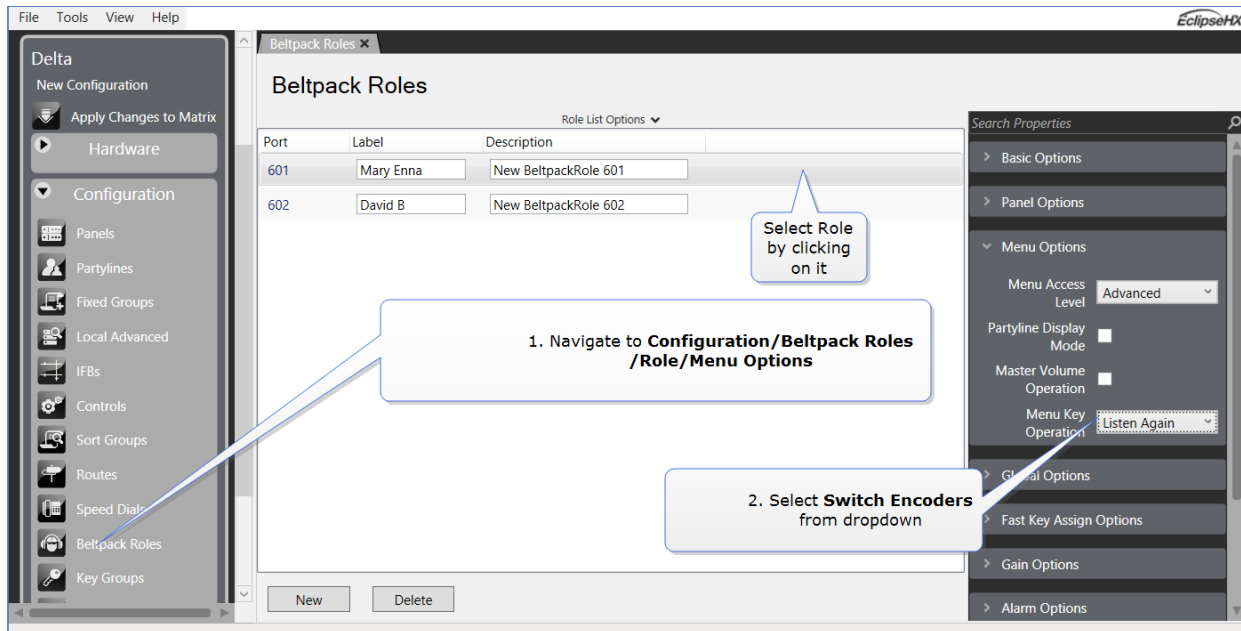

Figure 20-12 Select beltpack menu key operation

This change must be sent to the matrix before it takes effect. Click **Apply Map to Matrix**.

The beltpack user can now control audio volume on keys C & D using the rotary controllers (the same as for keys A & B) by giving the **menu** key on the beltpack a quick tap, instead of using this action to trigger Listen Again.

This **menu** key behavior option can also be set from the beltpack in **Menu/Settings/Menu Key Oper** if the user has advanced beltpack options.

20.2.4 Beltpack roles and properties

Beltpack roles define the beltpack in the same way as a label defines a key on a panel so that assigning a role to a beltpack has the effect of creating a label for it that can be referenced by other devices in the system such as a panel. The **Beltpack Roles** screen is only available if an FS II E-QUE antenna or splitter card has been configured in the matrix.

- 1) To create and edit beltpack roles, select **Configuration > Beltpack Roles**.

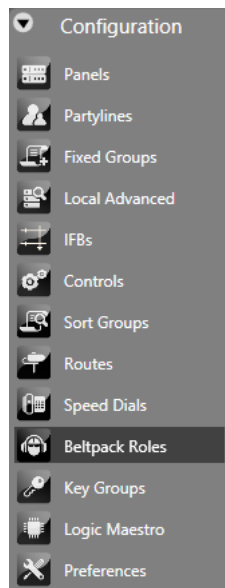

Figure 20-13 Beltpack Roles

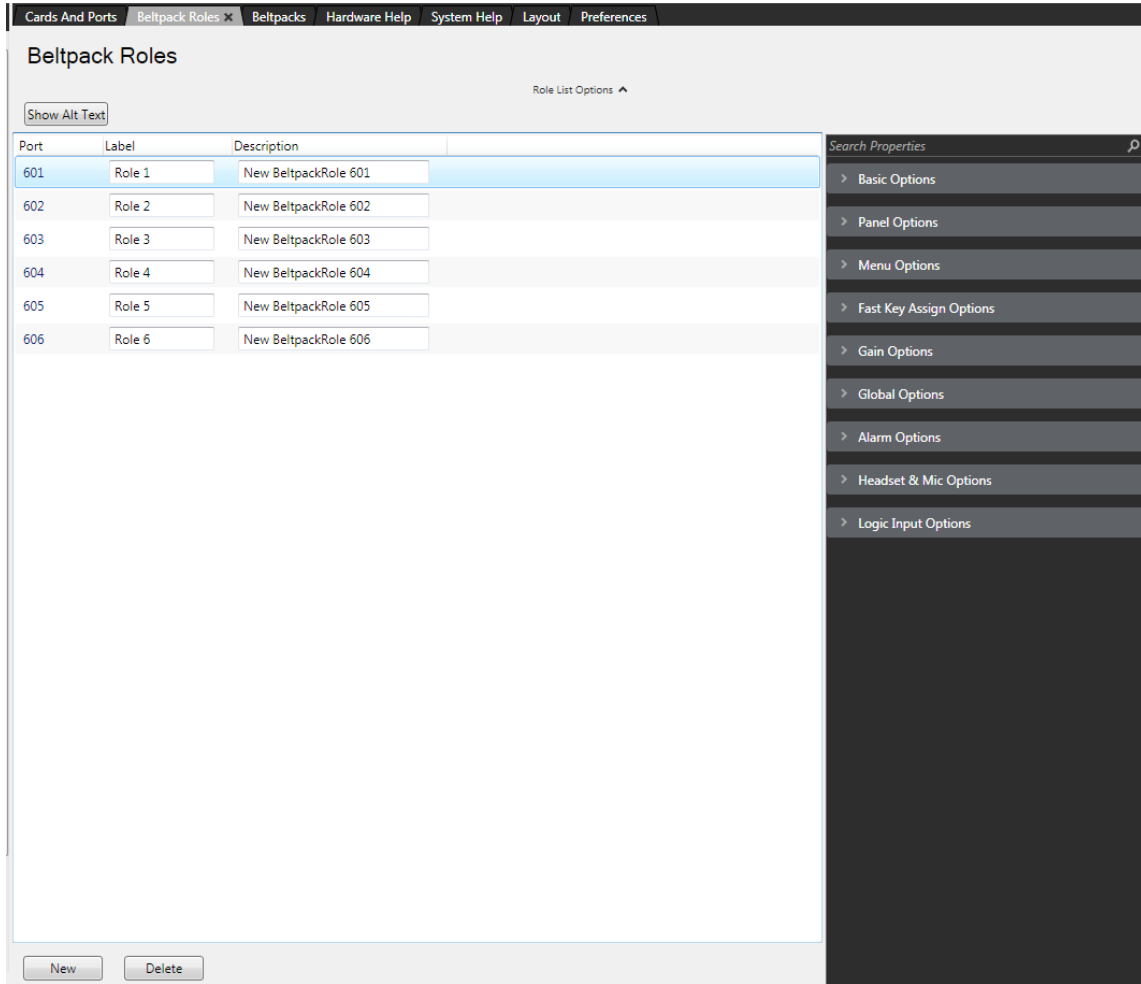

Figure 20-14 Beltpack Role Editor

- 2) To create a new beltpack role, click **New**. This adds a new role entry.
- 3) To edit the label and description, position the cursor in the description box and select the text to edit it.
- 4) To delete a role, select the role and click **Delete**.
- 5) To edit beltpack properties, select the beltpack role, and then select the required set of properties in the right hand side of the display.

You can edit the following beltpack properties:

- Basic Options
- Panel Options
- Menu Options
- Fast Key Assign Options
- Gain Options

- Global Options
- Alarm Options
- Headset and Microphone Options
- Logic Input Options
- Tally Options

20.2.5 Basic options

Port Number

Use this option to specify a unique identifier for the port (role) on the matrix.

Alias (Remote Matrix)

Use this option to allow labels to appear differently on remote systems compared to the local system. The maximum number of characters including spaces is 10.

Note: You can only edit this if the **Alias Label** setting is set to **Freely editable**. Go to **Configuration > Preferences > Intelligent Linking** and then select **Freely editable**.

Alt Text

Use this option to specify alternative text for the label. For example, you can set the label and alias to contain the role name and the user name respectively. Click **Show Alt Text** to display the alternative text.

Comments

Use this option to enter additional information about the beltpack role.

Description

Use this option to describe the port and what it is used for.

Dial Code

Use this option to enter a dial code that is used for panel fast key assign. See section **8.5.11 Fast key assign options**.

Label

Use this option to identify the role. The maximum number of characters including spaces is 10.

20.2.6 Panel options

Reply Tally Auto Clear Time

Use this option to set the period during which the Reply key will continue to flash after a call ends. You can disable this feature, or select a period between from OFF to 60 seconds.

Brightness Level

Use this option to set the brightness level of the beltpack display. You can select the following:

- 1 to 5 – the display is brighter up to the highest level (5).

Display Dim Timeout

Use this option to determine when the beltpack display dims if no buttons are pressed or no calls are received. You can select the following:

- Off – the display never dims
- 5 to 120 seconds

Display Off Timer

Use this option to determine when the beltpack display switches off if no buttons are pressed or no calls are received. You can select the following:

- 5 to 120 seconds after the Dim Timeout.

FS II configurable eavesdropping

Releases of FSII before 8.5.2 had the beltpack mic permanently open, meaning that audio coming from the beltpack could be listened to even if the user had no active talk routes. This feature can now be configured for each beltpack/Role in your wireless system. The default for FS II 8.5.2 and above is **Eavesdropping disabled**. However, earlier versions will revert to **Eavesdropping enabled**, the mic will remain open.

How to configure the eavesdropping feature:

- 1) From the EHX software navigate to **Configuration > Beltpack Roles > Beltpack Role > Panel Options > Eavesdropping**.
- 2) If you tick the checkbox, the mic on the headset will remain open, even when the user has no talk routes active.

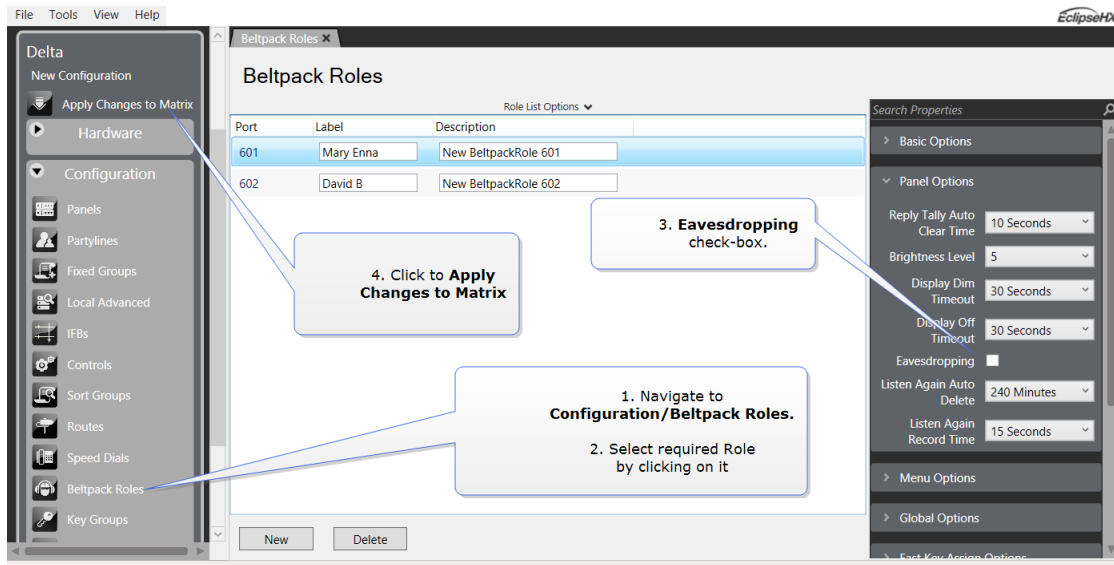

Figure 20-15 Set Eavesdropping mode on wireless beltpacks

Listen Again Auto Delete

Use this option to determine when a Listen Again message is automatically deleted. Listen Again is a feature that allows you to replay an incoming message by tapping the beltpack Menu key. You can select the following:

- Off – auto delete is disabled
- 30 to 240 minutes

Listen Again Record Time

Use this option to determine the length of Listen Again messages. Listen Again is a feature that allows you to replay an incoming message by tapping the beltpack Menu key. You can select the following:

- Off – Listen Again is disabled
- 1 to 15 seconds

Note: If the message exceeds the record time, the message wraps round to the start of the buffer and overwrites any previously recorded material.

20.2.7 Menu options

Menu Access Level

Use this option to determine which menu options a beltpack user can access. You can select the following:

- **Advanced**- all menu options are available.
- Normal – all menu options are available except:

- **Main > Volume Operation**
- **Main > Display Mode**
- **Main > Settings > Headset Options > Headset Limiter**
- **Basic** – all menu options are available except:
 - **Main > Volume Level Control**
 - **Main > Line In Volume Level**
 - **Main > Admin Options**
 - **Main > System Connect**
 - **Main > Information**
- **None** – no menu options are available except:
 - **Main > Admin Options** (admin code required)

Partyline Display Mode

Use this option to determine whether the beltpack display is in display partyline mode or display intercom mode.

Both display modes show information including beltpack role, signal strength, battery status and A and B channel volume levels. The intercom mode also shows key labels.

Master Volume Operation

Use this option to determine the behavior of the beltpack rotary controls. If you select this option, both rotary controls adjust the master volume of the beltpack. Otherwise, each rotary control (A and B) adjusts the volume of the crosspoint assigned on A or B.

Menu Key Operation

Use this option to control how the Menu key behaves.

- Listen Again – Replays up to 15 seconds of received audio
- Switch Volume Control – Switches the encoder volume controls from channels A and B to channels C and D.

20.2.8 Global options

IFB Caller Priority

Sets the priority of the port when it is used as a caller in an IFB. Sources and other callers with lower priorities will be dimmed. When the port is used as an IFB source, its priority is always 1. You can set the priority from No Cut to 5.

IFB

Select this checkbox to make the port an IFB destination. Sources are configured using the IFB Configuration screen or the Local Advanced screen.

IFB Attenuation

This option sets the dim level applied when a port talks to the IFB destination port. To set a port as an IFB destination, select **Global Options > IFB**.

Latch Disable

Use this option to disable key latching on all calls to the port. Key will remain active only while they are pressed.

20.2.9 Fast key assign options

Enable Assignment as Listen

Use this option to allow the port to be locally assigned to a listen key on a remote panel.

Enable Assignment as Talk

Use this option to allow the port to be locally assigned to a talk key on a remote panel.

Default Assignment as Talk and Forced Listen

Use this option to ensure that if the port is assigned to a remote panel, it will default to Talk and Forced Listen.

Protect Port from Assignment

Use this option to ensure that a panel user cannot change the default attributes of a key, for example assigning a listen attribute to a talk key.

Note: This option is only available if **Enable Assignment as Talk** is enabled, and **Enable Assignment as Listen** is disabled.

20.2.10 Gain options

Input Gain

Use this option to set the volume level of the input to the matrix port. You can select values from 0dB to -45dB.

Output Gain

Use this option to set the volume level of the output from the matrix port. You can select values from 0dB to -45dB.

Line-In Level

Use this option to set the volume level on the 3.5 mm local program feed to connector on the bottom of the beltpack. You can select values from -15dB to 6dB.

Beltback Master Gain

Use this option to adjust the beltpack master gain. You can select values from - 69.9dB to 0dB.

20.2.11 Alarm options

Battery Alarm Mode

Use this option to determine how the beltpack behaves when the low battery alarm triggers. You can set the following alarm conditions.

- Vibrate and audio warning
- Vibrate only
- Audio only
- Off – alarm disabled

Low Battery Threshold

Use this option to determine the battery level that triggers the low battery alarm. You can select values from 0% to 100%.

Call Alert Mode

Use this option to determine how the beltpack behaves when it receives a call. You can set the following alarm conditions.

- Audio warning
- Vibrate
- Audio warning and vibrate
- Off – alarm disabled

Out of Range Alarm

Use this option to determine how the beltpack behaves when it moves out of antenna range. You can set the following alarm conditions.

- Fade & Audio
- Fade Only
- Audio Only
- Off – alarm disabled

20.2.12 Tally options

Enables dimmed Tally lights (the default is enabled). When enabled, keys will always show a dimmed state of the active state.

20.2.13 Headset and microphone options

Headset Limiter

Use this option to prevent the headset audio becoming too loud. You can limit the audio level from -12dB to 8dB.

Headset Master Volume Low Level Limit

This feature sets the low level limit on the beltpack master volume in order to stop the beltpack being turned down so low that it cannot be heard. How this feature is used depends on your preferred working practice; it is possible to turn the master volume on the beltpack down so low that all audio is inaudible. This can cause confusion among the unwary, although some users may want to turn the volume down completely on some occasions.

The low level limiter can be set from the configuration software, or from a beltpack menu (as long as the beltpack has advanced menu options).

Set the beltpack master volume low level limiter in EHX

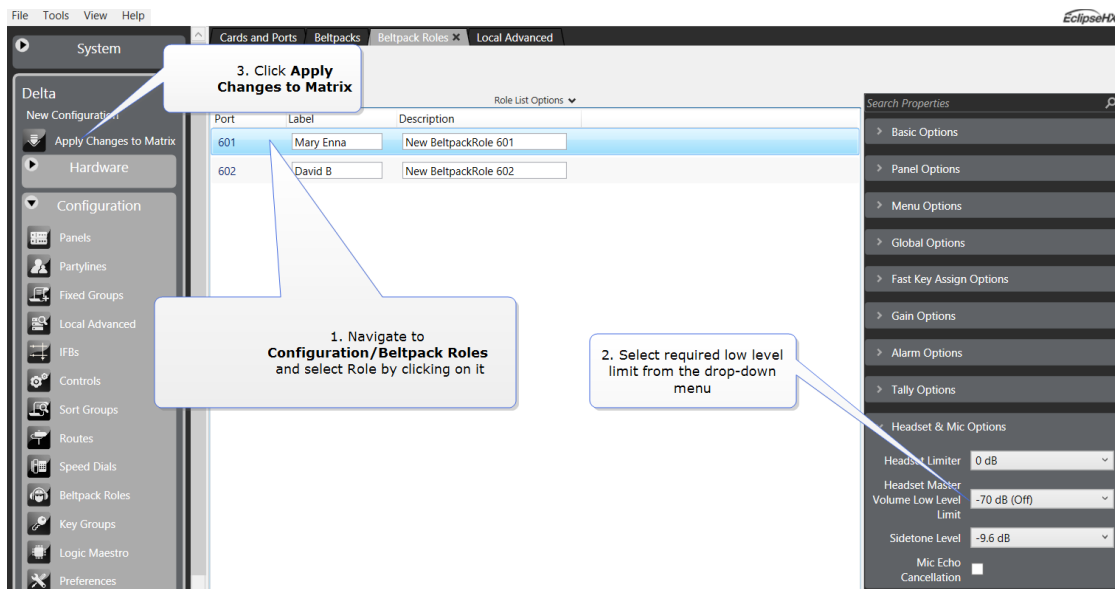

Figure 20-16 Set beltpack master volume low level limiter

Note: Changes made to Roles in EHX must be sent down to the matrix before they take effect. Click **Apply Map to Matrix**.

Set the beltpack master volume low level limiter in the beltpack menu (advanced menu options only)

From the beltpack, press and hold the **menu** button for 2 seconds to enter menu mode. Navigate to: **Settings/Headset options/Low level limiter** and select the required low level limit.

Sidetone Level

Use this option to determine how much audio from the headphone microphone feeds into the headphone. You can select a sidetone level from -69.9dB to 0dB.

Mic Echo Cancellation

Use this option to improve the quality of the microphone voice audio.

20.2.14 How to set AA battery type: Nickel-metal hydride (NiMH) or Alkaline for wireless beltpacks

FreeSpeak II wireless beltpacks are supplied with Li-ion batteries and battery charger. However, in some cases you may wish to use AA batteries. Alkaline batteries can be used as a quick, easily available replacement. NiMH batteries can be used in environments (for instance, high atmospheric/hyperbaric) where Li-ion batteries are prohibited.

When using AA batteries of either kind, it is helpful to set battery type so that battery capacity can be monitored accurately. NiMH batteries and alkaline batteries have different discharge patterns and setting this option will allow for that.

AA Battery type must be set in the EHX software. It is a global setting and will apply to all beltpacks in your system.

- 1) Select **Preferences > Wireless Beltpacks > Battery type**.
- 2) Select required battery type, NiMH or Alkaline.

Note: The default setting for AA battery type is **Alkaline**

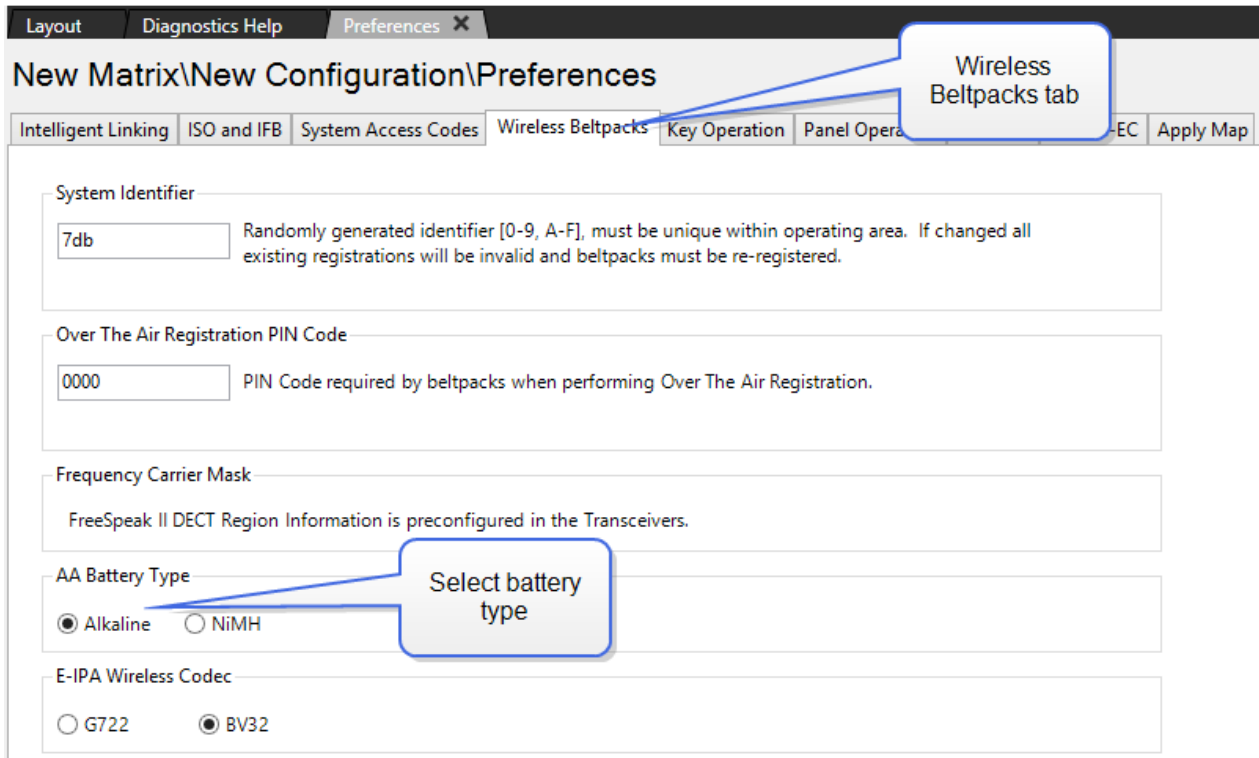

Figure 20-17 Set Battery type

You must send this change to the matrix before it takes effect. Click **Apply Map to Matrix** in the EHX software.

20.2.15 Logic input options

FreeSpeak II beltpacks can use a 7-pin microphone. These headphones have two PTT keys that you can configure to behave, for example, like a beltpack reply key or to activate a radio talk key.

There are two logic inputs (1 and 2). For each one, you can choose between the following options:

- **No Function** – This disables the Logic PTT key.
- **Activate Reply Key** – The Logic PTT key behaves like a FreeSpeak II beltpack Reply key.
- **Activate Configured Action** – The Logic PTT key activates a specified audio port. When Route is selected, you can specify the destination and the route type in the **Route Destination** and **Route Type** fields.
- **Activate All Pre-Selected Talk Keys** – The Logic PTT key must be pressed before beltpack talk keys can create audio routes.
- **Activate All Pre-Selected Two-Way Radio Talk Keys** – The Logic PTT key must be pressed before beltpack two-way radio keys can create audio routes.

- **Activate Reply, then Clear Label** – The microphone key behaves like a FreeSpeak II beltpack Reply key, however on key release the reply is removed from the stack.

20.2.16 FreeSpeak II™ beltpack programming

You can use the **Panels** configuration screen to configure beltpack roles to determine how they behave. For example, you can assign labels to keys and set beltpack operating parameters. The beltpack is treated as if it were a panel, allowing you to drag and drop labels onto keys. To program a beltpack:

- 1) Select **Configuration > Panels**. The Beltpack Programming screen appears.

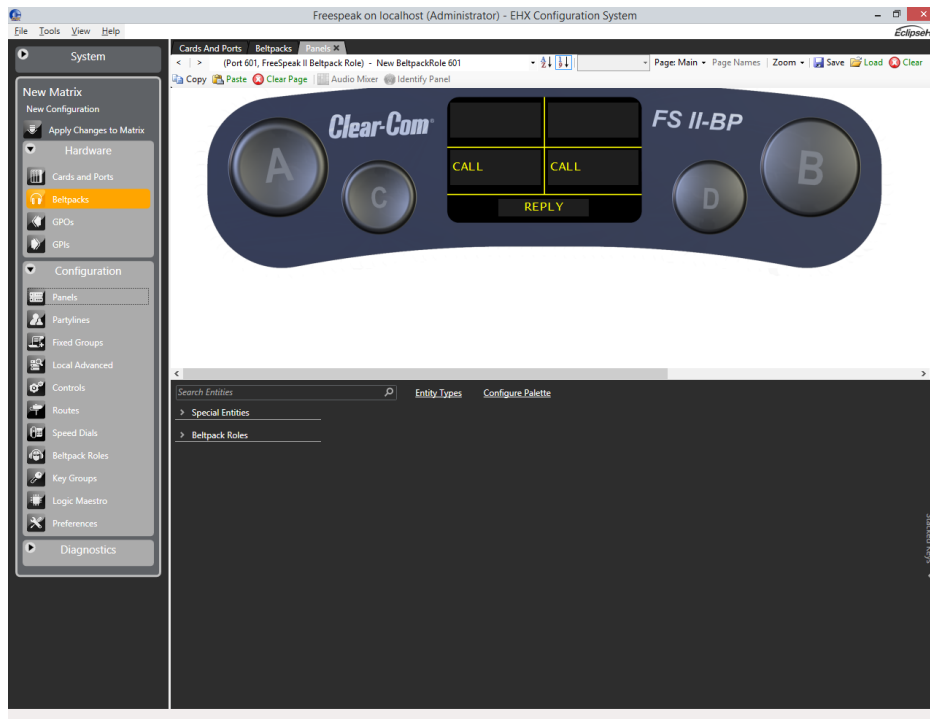

Figure 20-18 Beltpack Programming Screen

- 2) From the drop-down list at the top-left of the screen, select the required beltpack.
- 3) Drag and drop labels from the bottom of the screen onto the required beltpack keys. Buttons A, B, C, D and the Reply Key can be assigned.

Note: When the cursor hovers over a key, the status of the key is displayed showing the key number and the key type.

- 4) Right click a key to open a key configuration menu allowing you to configure the key type, local assignment, interlock group and latch disable.

Activation

Use this option to determine how the key behaves when activated with the pushbutton

- 5) Right click the required key to display the options menu, and then select **Activation**.
- 6) Select from the following options:
 - Talk - sets a talk from the beltpack to a destination with no automatic listen to the destination
 - Listen - sets a key to listen to the source without talking to the destination at the same time. Use the rotary control to increase listen level.
 - Talk and Listen - sets a talk key with listen Use the rotary control to increase listen level.
 - Talk and Forced Listen - sets a talk key with permanently made listen Use the rotary control to increase listen level.
 - Dual Talk and Listen - sets a dual talk and listen key. This makes the pushbutton activate a talk and listen on a press and hold or latch a Listen with a short press and release on the same pushbutton.

Local assignment

Use this option to enable or disable local key assignment.

- 7) Right click the required key to display the options menu, and then select **Local Assignment**.
- 8) Select between:
 - Allow Local Assignment
 - Disallow Local Assignment

Interlock group

Use this option to assign several keys on a beltpack into a selector group and restrict the group so that only one key of the group can be activated at any one time. This function only refers to talk paths.

For example, if a beltpack has three keys programmed to talk to cameras 1 to 3 then by setting these into an interlocked group only one camera key can be selected at a time.

You can assign any or all beltpack keys to nine available interlocked groups.

To add a key to an interlocked group

- 9) Right click the required key to display the options menu, and then select **Interlock Group**. A list of Interlock Group options appears.
- 10) Select the required interlock group or **None** if the key is not to be in any interlock group. The key interlock groups appear in the key information popup shown when the cursor hovers over a key.

Note: You can also add the key to other interlock groups.

Local advanced latch disable

Use this option to set key latching:

- 11) Right click the required key to display the options menu, and then select **Local Advanced Latch Disable**.
- 12) Select **On** or **Off**.

Go to key destination

Use this option to display the **Matrix Hardware Editor** screen with the destination the key refers to highlighted. Right click the required key to display the options menu, and then select **Go to Key Destination**.

Delete key

Use this option to remove a key label. Right click the required key to display the options menu, and then select **Delete**.

20.2.17 Upgrading beltpack and antenna firmware

You can upgrade the FreeSpeak II beltpack firmware by:

- Using a USB connection
- Using an Over The Air (OTA) upgrade.

You can upgrade the antenna firmware by:

- Using a USB connection
- Using central upgrade from the matrix to all connected antennas via the E-QUE card.

Upgrading FS-II beltpacks and antennas by USB connection

- 1) Connect the beltpack or antenna to a USB port on the computer running the EHX software.
- 2) Select **Tools > Apply Wireless Firmware Via USB**.

- 3) Browse to the location of the upgrade file, and then select **Update Firmware**.

The upgrade file is applied to the beltpack or antenna.

Note: You can connect more than one beltpack or antenna to the computer if you have multiple USB ports. The units will be upgraded sequentially.

Upgrading beltpack firmware by Over The Air Upgrade

- 1) Right-click on the Frame in the Layout window, and then select **Firmware > Update Firmware**. The Update Firmware Wizard appears.
- 2) Select **Next**. The following screen appears:

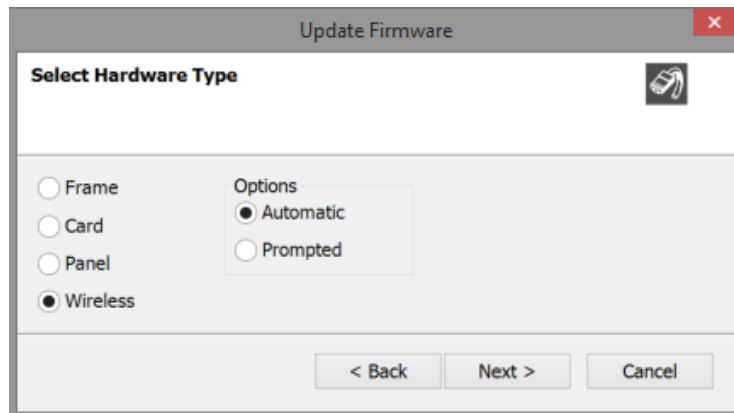

Figure 20-19 The Update Firmware screen

- 3) Select the **Wireless** radio button. There are two further options:
 - Automatic – select this option to automatically upgrade the beltpack when it is switched on.
 - Prompted – select this option to allow the beltpack user to confirm the upgrade.
- 4) Select **Next**, and then browse to the upgrade file (**.fww**) and select **Open**. The upgrade file is loaded to the antenna. The upgrade file is applied to all the connected beltpacks, and the beltpacks automatically restart.

Note: The antennas store the beltpack upgrade files until they are power cycled or there is a black reset.

Note: You can track the status of the apply in the EHX Event Log, and for beltpack upgrades the upgrade status is also shown on the beltpack display.

Upgrading antenna firmware

- 1) Right-click on the Frame in the Layout window, and then select **Firmware > Update Firmware**. The Update Firmware Wizard appears.
- 2) Select **Next**. The following screen appears:

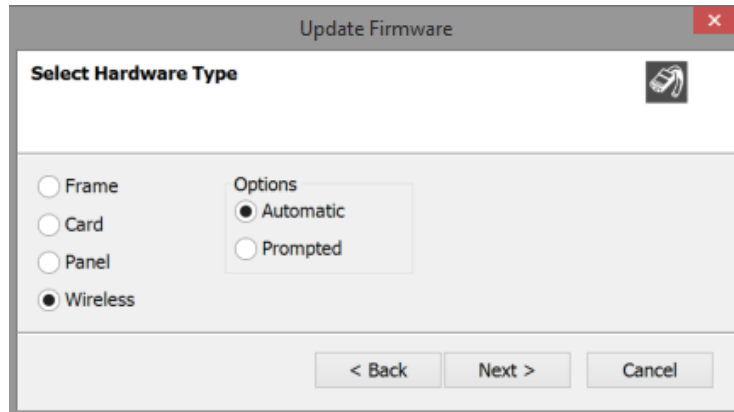

Figure 20-20 The Update Firmware screen

- 3) Select the **Wireless** radio button.
- 4) Select **Next**, and then browse to the upgrade file (**.fww**) and select **Open**. The upgrade file is loaded to the antenna, and the antenna restarts.

Note: You can track the status of the apply in the EHX Event Log.

20.2.18 Wireless beltpack preferences

From **Configuration > Preferences > Wireless Beltpacks** you can configure the system identifier and DECT parameters for CellCom / FreeSpeak / FreeSpeak II wireless beltpacks.

For CellCom and FreeSpeak (but not FreeSpeak II), a password is required to access the DECT Frequency Carrier Mask configuration facility. For FreeSpeak II, this is not configured in the EHX software. For more information, contact Clear-Com support.

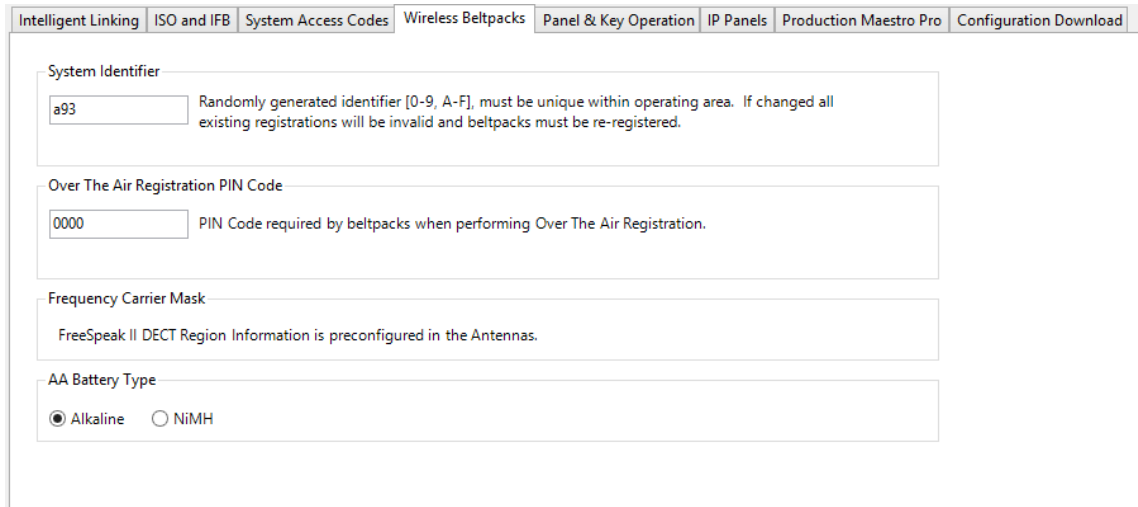

Intelligent Linking | ISO and IFB | System Access Codes | **Wireless Beltpacks** | Panel & Key Operation | IP Panels | Production Maestro Pro | Configuration Download

System Identifier
a93 Randomly generated identifier [0-9, A-F], must be unique within operating area. If changed all existing registrations will be invalid and beltpacks must be re-registered.

Over The Air Registration PIN Code
0000 PIN Code required by beltpacks when performing Over The Air Registration.

Frequency Carrier Mask
FreeSpeak II DECT Region Information is preconfigured in the Antennas.

AA Battery Type
 Alkaline NiMH

Figure 20-21 Wireless Beltpacks Tab

To configure the DECT frequency:

- 1) Click **Configure**, and enter the DECT configuration password to display the DECT configuration screen (Select Frequency Region).

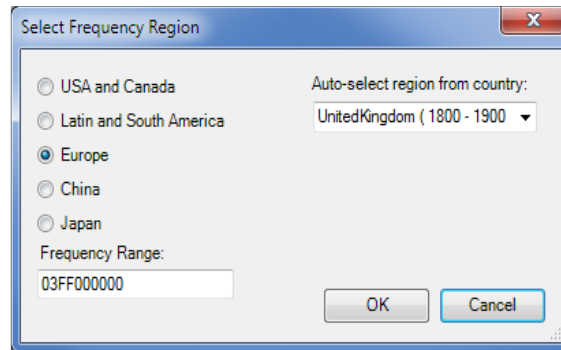

Figure 20-22 Select Frequency Region

The frequency range used by the wireless system can be set:

- Directly by entering the required value into the field.
- By selecting the appropriate region, using the radio buttons.
- By selecting the country where the wireless system is used from the drop-down menu.

If you use either of the last two options, the correct frequency range value is automatically inserted.

- 2) To confirm the frequency range, click **OK**.

Over the air registration PIN code

Enter a four-digit PIN code to allow FreeSpeak II beltpacks to register wirelessly with antennas. The default PIN code is 0000, but Clear-Com strongly recommends that you change this for security reasons.

AA Battery Type

Select between Alkaline and NiMH.

20.3 IP Transceivers (IPTs)

You can configure IPTs from the E-IPA-HX card. For more information about the E-IPA-HX card, see **15 Adding and configuring an E-IPA-HX card**.

21 Telephone audio routes in Eclipse matrices

You can send and receive telephone calls from an Eclipse matrix in two ways:

- Configure an LQ SIP port in either the MVX-A16 card or IVC-32 card. This enables you to send and receive SIP calls using a connected LQ device.
- Configure a TEL-14 port in the MVX-A16 card. This enables you to send and receive call using a TEL-14 telephony Interface that is connected to the matrix.

21.1 Telephone calls using LQ SIP

Session Initiation Protocol (SIP) is an established technology that enables you to connect external telephones lines to your intercom system, expanding the reach of your communications.

Note: You must purchase a license to use LQ SIP connectivity. Please contact your Clear-Com dealer for more information.

21.1.1 What is SIP?

SIP is an application layer (signaling) protocol that is used to create, modify and terminate sessions for voice, for one or more participants.

SIP User Agents

- SIP client: makes and terminates requests
- SIP server: accepts and administrates requests

Connect a SIP telephone line to your matrix. This allows you to talk to an external telephone from a panel.

You can set up LQ SIP connectivity in a matrix using:

- An IVC-32 card that creates an IP connection between an LQ device and a matrix.
- An MVX card that creates a 4-wire plus data connection between an LQ device and the matrix.

Note: The LQ device must be connected to the same network as the SIP server. The LQ unit must be able to see (contact) the SIP server, see your network administrator if you have any connectivity problems.

If connecting over separate networks, you must use port forwarding rules. For more information, see the *LQ User Guide*.

21.1.2 Making outgoing calls using SIP

The following methods are possible:

- Speed dials

- Prepared dialing
- Using Dynam-EC

Speed dials

Speed dials can be set up in the EHX software to work with a specific interface and number. A speed dial is created and attached to a control in the EHX software, the control is put on a key and then this key is put on a panel. To use a speed dial once it is configured, latch the interface key and then press the speed dial key. You can also press the speed dial key first, and then latch the interface key.

When configuring a speed dial, the interface and the control (the number to dial) can be stacked on the same key to reduce the number of keys used to dial a set number. See **18.6 Speed dials using SIP and TEL-14** and **17.3 Stacked keys**.

Prepared dialing

When using prepared dialing, the number is dialed first (use the panel keypad or dial menu) and the interface (panel key) is selected second. This method of dialing is more flexible when it comes to possible numbers to dial and the dial route.

Once a SIP call has been initiated (using speed dial or prepared dialing), the dial pad (or dial menu) can be used to send digits to the exchange, for example to traverse remote PABX menus.

21.1.3 Accepting incoming SIP calls

When a call comes in on an interface, the LQ system will auto-answer the call.

Exactly how incoming calls behave depends on how the **Off-Hook Tally** and **Line Release** options are set.

If the Off-Hook Tally is set to ON, an incoming call configured to a panel will flash on the interface key. Use the panel keyset to monitor and talk back to the calling party. An incoming call can be ended by the caller. If the Line Release option is set in EHX then the call can also be released by the panel.

21.1.4 DTMF options

- DTMF options can be used to set a passcode (for security) on an incoming call.
- DTMF options can be used to add an extension on a dialed number.
- You can set DTMF codes to **Accumulate:** Number [passcode] extension

For more information about DTMF options, see **8.5.14 DTMF options**.

21.1.5 Configuring LQ SIP

- 1) From the EHX software, navigate to **Hardware > Cards and Ports**

- 2) Select or add an **MXV-A16** card or an **IVC-32** card. (See section **8.2 Adding an MXV-A16 card (manual)** or section **10.2 Adding an IVC-32 card (manual)**).

Note: For IVC-32, navigate to **IP Port Options**, and make a note of the User ID and Password for each port. You need them to enable the connection between LQ and matrix card.

- 3) From the Port Function drop-down, select **LQ SIP**.
- 4) From **Telephone Options**, select any preferences, such as **Off Hook Tally**.

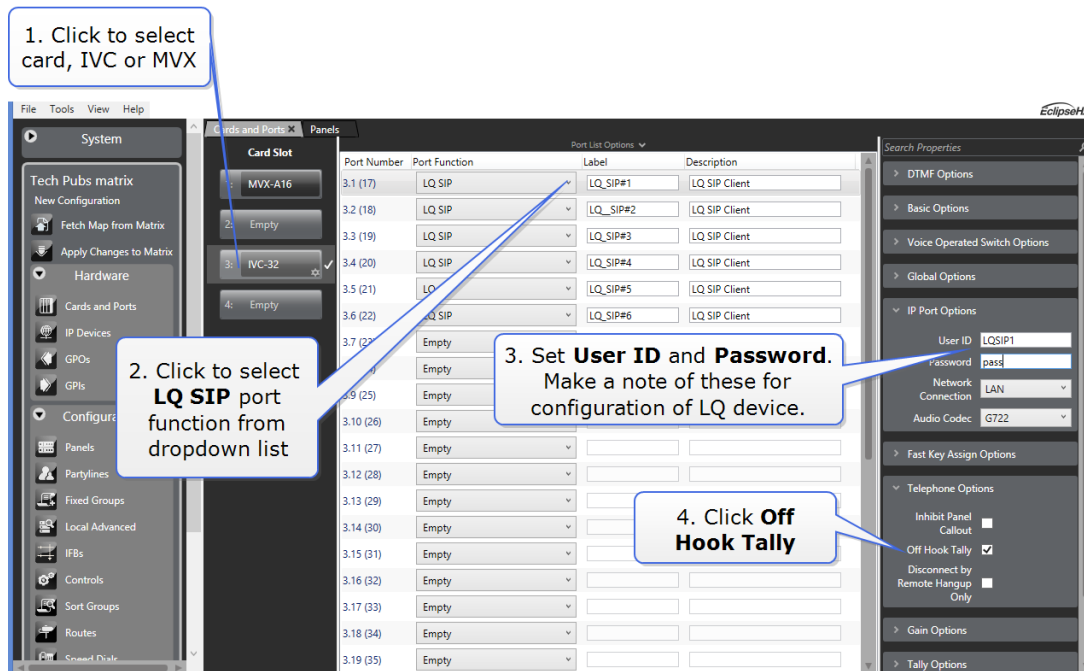

Figure 21-1 Configuring LQ SIP

- 5) In the EHX software, navigate to **Configuration > Panels**.
- 6) Assign a Talk and a Listen to a panel key. For more information, see **17.7 V-Series panel programming**.

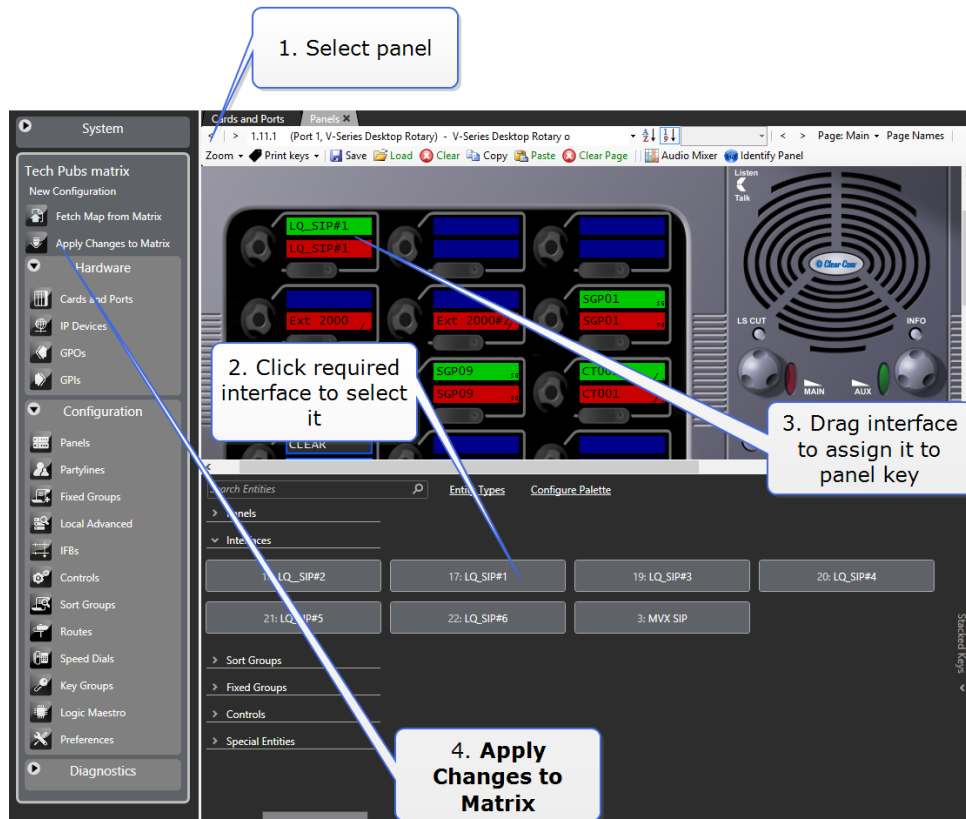

Figure 21-2 Configuring LQ SIP

7) To apply changes to the matrix, click **Apply Map to Matrix**.

Note: You can dial an external number using the panel keypad. For convenience, you can also program a speed dial. For more information, see **18.6 Speed dials**.

21.2 Telephone calls using TEL-14

The TEL-14 module enables telephone calls directly from any panel in an Eclipse matrix to a POTS line.

21.2.1 Configuring TEL-14

- 1) Select **Hardware > Cards and Ports**.
- 2) From an MVX card slot, create or select a TEL 14 port. See section **8 Adding and configuring an MVX-A16 card**.
- 3) Select **DTMF Options**
- 4) Select **Access Prompt**, and then select **Enable DTMF Passcodes** and open the drop-down menu listing the passcodes configured under **Configuration > Preferences > System Access Codes**.

5) Select the Passcode by placing a tick in the check box beside the required password.

6) To apply the changes to the matrix, select **Apply Map to Matrix**.

The selected Passcode is then specific to that TEL-14 interface.

21.2.2 Inward DTMF access

Note: DTMF tones are not supported on LQ SIP.

DTMF Access allows combinations of DTMF tones that are pre-assigned with specific meanings to have access to the Eclipse HX system. The Assign DTMF Codes option in Advanced Setting screen of a telephone screen allows you to set all parameters related to the DTMF-tone decoding. Each MVX-A16 Crosspoint Card provides sixteen ports. On each MVX card, DTMF Daughter boards are fitted for DTMF-tone encoding and decoding. DTMF decoding is the ability to interpret DTMF tones. DTMF encoding is the ability to create DTMF tones.

Assign DTMF codes are numerical routing codes that outside callers use to access the system. The codes initiate the specific audio paths when the system is accessed via DTMF inward access. If the [One Digit Codes] field is selected, only the ten single-digit codes [0] through [9] function as selector codes.

If the **Accumulate DTMF Codes** option is selected in **DTMF Options**, the inward DTMF stream may contain multiple routing codes, for example to activate more than one audio route/control. If this is the case it is advisable to separate the selector codes by placing a space in the source string to ensure that selector codes after the first are correctly identified.

Note: The characters used to specify a space or pause between codes may vary with the equipment calling into the Eclipse HX system. Consult the manufacturer's instructions for details.

Specific Control codes perform specific functions, including:

00 - Clear Last Entry—This code clears the paths that were activated by the last selector code entry. If [00] is entered twice, the paths that were activated by the last two selector code entries clear, and so on.

91 - Send Call Signal—This code sends a call from the port to the matrix as if a call signal was sent by an external device connected to the port.

92 - Disable DTMF Decoding—This code turns off DTMF decoding. This may be desirable because certain program sources may contain DTMF tones not intended to be interpreted as selector codes, and that can inadvertently reroute the audio path. For more information, see section **21.2.7 Configuring DTMF access codes**.

99 or 099 - Clear All—Either of these codes clear all currently active talk and listen paths.

Access Prompt tones are tone sequences that the MVX-A16 sends to the user. The MVX-A16 issues the following four distinct prompt tone sequences:

Access Code Request—Indicates that the system is ready for an access code to be entered. If the system does not recognize the entered access codes, it repeats the access code request prompt. The number of attempts to enter the access code is limitless. The prompt consists of a low tone followed quickly by a higher tone. The sequence is quickly repeated three times.

Access Granted—Indicates that the system has acknowledged the access code and that access to the Eclipse HX matrix has been granted. The prompt consists of four tones, each increasing in pitch and immediately followed by a ready prompt.

Ready—Signals that the system is ready for a selector code entry. It also indicates that it has acknowledged the last selector code entered. The prompt consists of a single high-pitched tone.

Error—Indicates that an invalid code has been entered. Error prompts result from:

- Selecting a code that is less than 10 or greater than 59
- Selecting a code without talk or listen labels assigned to it
- Assigning a control code before a port has been activated.

21.2.3 Multiple codes

If the Multiple Codes is set to false only one selector code can be active at a time. Entering a second selector code automatically deactivates any audio paths that were activated by the previous selector code. If this field is set to true, any number of selector codes can be active at the same time. To deactivate a selector code, either enter the selector code number preceded by a zero or enter a clear last or clear all control code.

21.2.4 One digit codes

If One Digit Codes is set to true the selector codes are limited to one digit—0 to 9—plus the quick keys—pound (#) and asterisk (*). These codes are easier to remember and dial. However, they also have the following limitations:

- Only ten codes are available
- Control codes are not recognized
- The pound and asterisk keys can only be assigned a single digit code
- The system no longer recognizes the **0<selector code>** form, which deactivates any established individual path. This means if multiple codes, has been enabled a previously established path cannot be deactivated.

21.2.5 First code only

If the First Code Only is set to true the DTMF tone detection is disabled after the first valid code has been received. DTMF decoding can also be disabled by entering the disable DTMF decoding control code (92), described in the Control Codes section.

Certain circumstances may encourage the disabling of DTMF-tone detection. During normal operation, DTMF tones in the port's audio input are decoded at all times. However, certain audio program sources— such as telephone company commercials—may contain DTMF tones that are not intended to be interpreted as selector codes, and can inadvertently reroute the audio path. Certain voices or musical instruments can also fool the DTMF tone detection circuitry into detecting false DTMF tones.

By disabling DTMF-tone detection after the program feed has been set up, the paths are not accidentally rerouted. To re-enable tone decoding, hang up and call back again.

21.2.6 Quick codes

These menus define the Touch-Tone keypad's asterisk (*) and pound (#) keys as quick keys using quick codes. If a two-digit pair (corresponding to one of the valid selector codes or control codes) is selected from the menus for the asterisk or the pound, the DTMF port translates the asterisks or pound's DTMF tone into that two-digit code. For example, if the asterisk key is supposed to clear all paths, select [00] from the [*] menu. If the [One Digit Codes] box is checked, the quick keys cannot be assigned control codes.

21.2.7 Configuring DTMF access codes

Multiple code setup

Multiple codes enable an operator to stack multiple routes so that having called one destination a sequential call can be made to a further destination without ending the first call.

Assign DTMF codes

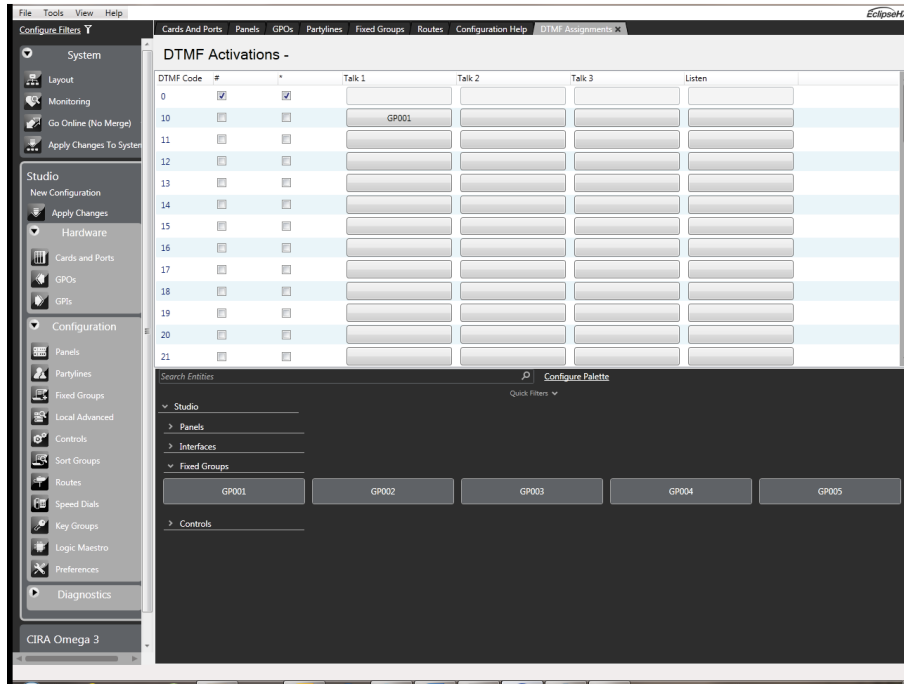

Figure 21-3 DTMF Activations

- 1) From the telephone’s Advanced Setting screen select Assign DTMF Codes to open the DTMF Assignments screen.
- 2) Select the desired destination label from the palette of available destinations, at the bottom of the screen.
- 3) Find the desired code in the DTMF Codes column.
- 4) The columns to the right of the DTMF Codes column allow assigning as many as three talk labels and one listen label for each key. Click in the column for the desired type of label for the desired code: Talk 1, Talk 2, Talk 3, or Listen. The selected label appears in the desired cell. If this cell has already been assigned a label, the new label displaces the old one.
- 5) Apply the new configuration to the matrix with an Apply Label Changes.

Note: Although above describes a single route multiple routes can be attached to a control.

One digit code setup

To assign the one-digit selector codes (numbered 0 through 9), set the [One Digit Codes] field in the Advanced Settings screen for a telephony interface to true.

- 1) From the telephone's Advanced Setting screen select Assign DTMF Codes to open the DTMF Assignment screen.

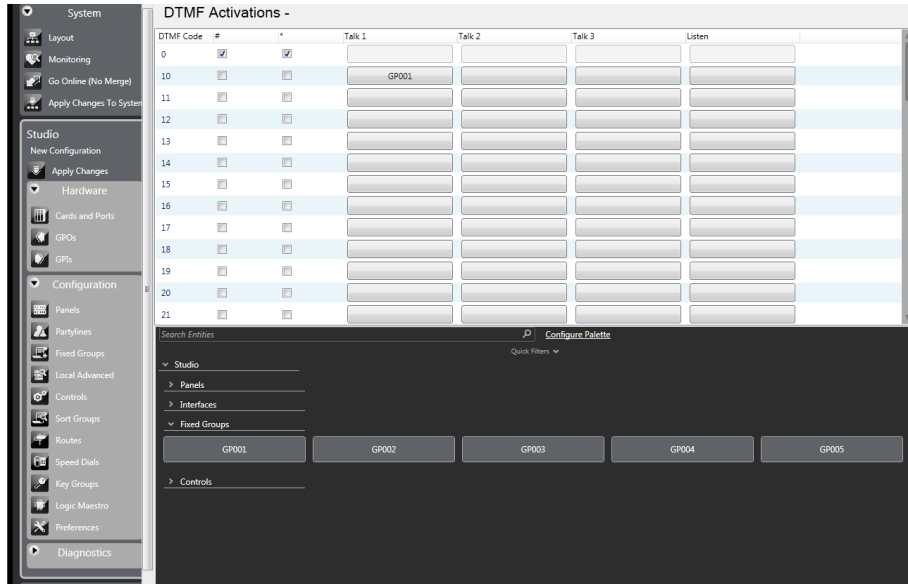

Figure 21-4 Single Digit DTMF Assignments

- 2) Select the desired destination label from the palette of available destinations, at the bottom of the screen.
- 3) Find the desired code in the DTMF Codes column.
- 4) The columns to the right of the DTMF Codes column allow assigning as many as three talk labels and one listen label for each key. Click in the column for the desired type of label for the desired code: Talk 1, Talk 2, Talk 3, or Listen. The selected label appears in the desired cell. If this cell has already been assigned a label, the new label displaces the old one.
- 5) Apply the new configuration to the matrix with an Apply Label Changes.

22 IP devices

22.1 Introduction to IP devices

The IP Devices screen allows you to centrally manage IP panels, IVC-32 cards and Concert users.

To start IP Devices, select **Hardware > IP Devices**.

The initial IP Devices display shows three panes for managing the configuration of IP panels, Concert users, IVC-32 IP interface cards and Agent-IC panels.

When IP Devices is opened it automatically searches for IVC-32 cards in configured matrix and IP enabled V-series panels on the same network as the configured matrix.

Note: EHX operators should not open more than one instance of IP Devices to assign or monitor IP panels on the same matrix at the same time.

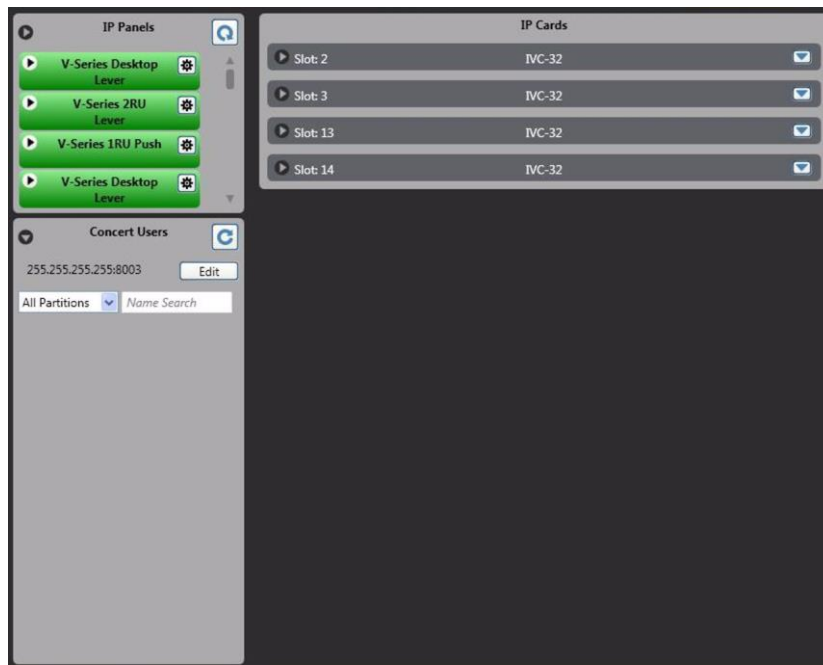

Figure 22-1 IP Devices screen

The IP Panels and Concert Users panes have a menu button in the top left corner for opening menus for diagnostics and the discover button in the top right corner to start EHX searching for the specified items.

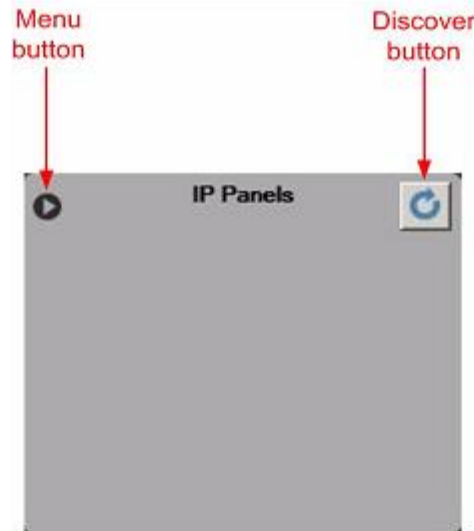

Figure 22-2 IP Devices Pane Buttons

- 1) Click on the menu button to open the menus associated with the type of IP device associated with the pane.
- 2) Click on the discover button at the top left corner of the IP Panels panel to search for all the IP panels on the network.

The IP Cards pane has a similar layout but does not have a discover button. Instead the left-hand button on the header bar opens or closes the list of IVC-32 cards detected in the current matrix.



Figure 22-3 IP Cards Pane

Use the left and right buttons on each IVC-32 card display to open displays for the individual cards.

22.2 IP panel preferences

Use this tab to determine the default Codec and IP port to be used by the IVC-32 card when communicating with panels over IP. You can also configure the jitter

buffer. For more information about jitter, see section **22.7 IVC-32 card panel list**.

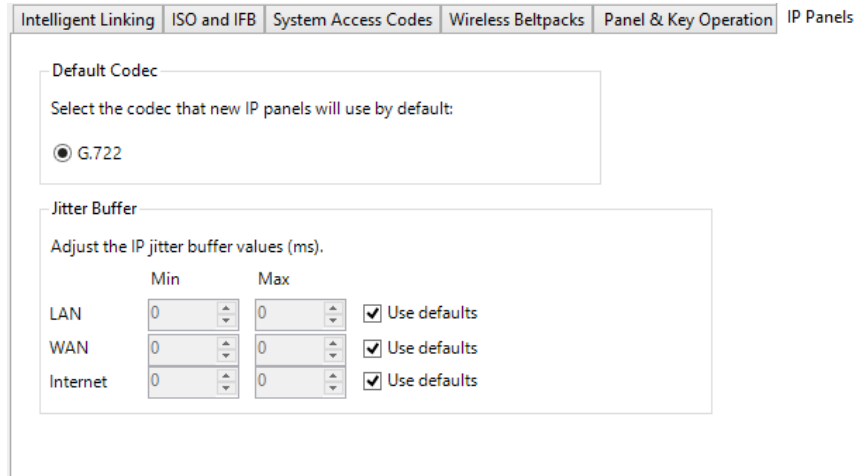

Figure 22-4 IP Panels tab

The Codec option specifies the algorithm used to compress the audio in digital form for transmission over IP. Currently the default is G.722. It cannot be disabled.

The remaining IVC-32 card parameters such as IP address and port are configured in Cards and Ports.

To configure the jitter buffer, use the up and down arrow keys to select a maximum and minimum value for LAN, WAN or Internet. For defaults, select **Use defaults**.

22.3 IP panels

- 1) Click on the IP Panels discover button to search all the systems on the network for IP enabled V-Series panels and display all the panels detected as a list.

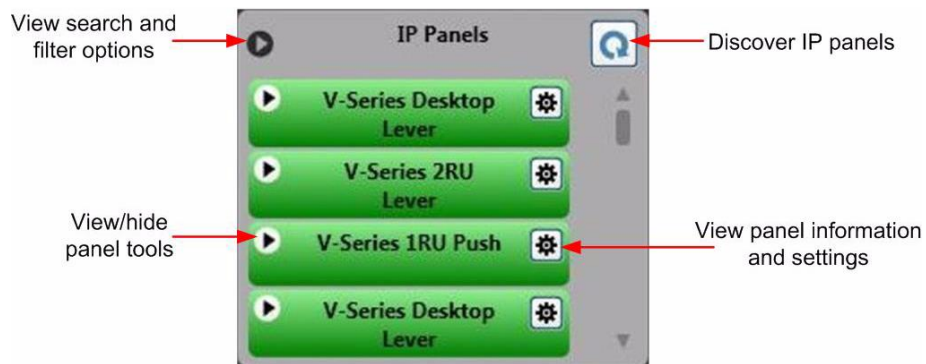

Figure 22-5 IP Panel List

The panels listed are color coded according to status. The color codes are:

- **Blue** - panel has been discovered but does not have a login IP address, User ID or password configured.
 - **Green** - panel has been discovered and is logged in to the current configuration.
 - **Amber** - panel has been discovered that is configured in this configuration but is not logged in.
 - **Gray** - panel has been discovered with an IP address that is not for the matrix in this configuration. The panel may be configured for another matrix and may be logged in to that matrix.
 - **Red** - panel has been discovered that is not in one of the other states. The panel may be configured for this matrix but is not in the current configuration.
 - **Mauve** - panel has been discovered but the panel status is undetermined. Panels may be displayed in this color briefly during discovery until the panel status is established and the color then changes to reflect the panel status.
- 2) Click the left button of a panel entry to display an Identify Panel button.



Figure 22-6 Identify Panel Button

- 3) Click on the identify button to request that the panel enters its **IDENTIFYME** mode with the panel LEDs flashing red across the panel. The **Identify Panel** text is displayed in bold and a red bar moves across the button to show that the mode is active.

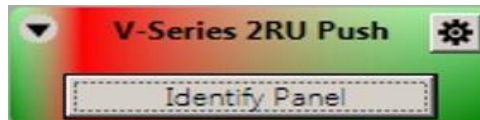

Figure 22-7 Identify Function Active

- 4) Click the button again to end the identify mode.
- 5) Click the right button to display a list of all the available information about the panel.

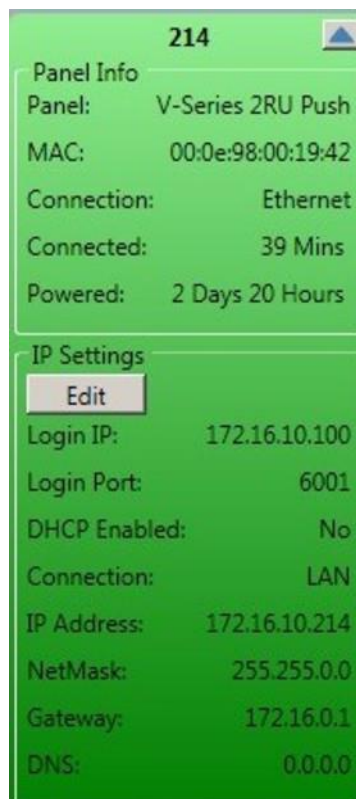

Figure 22-8 IP Enabled Panel Info

The panel information displayed shows the following:

- Panel - panel type.
- MAC - panel MAC address.
- Connection - the protocol used in the panel connection.
- Connected - the length of time the panel has been connected without a reset.
- Powered - the length of time since the panel was last powered up.

The IP settings displayed are the same as those set on the panel using the panel IP setup menus (see the **V-series manual**).

- **Login IP** - the IP address of the IVC-32 card that the panel tries to log in to.
- **Login Port** - the port the panel uses to log in to the IVC-32 card.
- **DHCP Enabled** - whether the panel should obtain an address from a DHCP server or use a preset address.
- **Connection** - the type of connection: WAN, LAN or Internet.
- **IP Address** - the IP address of the panel.

- **Netmask** - the subnet mask for the network the panel is on.
 - **Gateway** - the IP address of the gateway to be used when connecting to the matrix.
 - **DNS** - the IP address of the Domain Name Server to be used by the panel to obtain an IP address automatically if DHCP is enabled.
- 6) Click Edit to enable the IP settings to be changed from IP Devices.



Figure 22-9 Editing IP Panel Settings

- 7) When the edits are completed click on the tick button to accept the changes or the cross button to cancel the changes.

If a parameter is set to an invalid state, such as part of an IP address being set to a number greater than 255 the error is flagged by a red border around the item when attempting to save it. The invalid entry is not sent to the panel and the entry is reset to the original value if edit mode is cancelled.

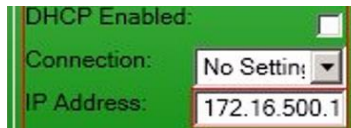

Figure 22-10 Panel Setting Error in Edit Mode

Note: Care should be taken when making some changes as they may prevent the panel from logging in to the IVC-32 card, for example by changing the login IP or login port.

- 8) Click on the left arrow button at the top of the IP Panels pane to display the panel filter facilities allowing panels to be filtered by state and/or by name.

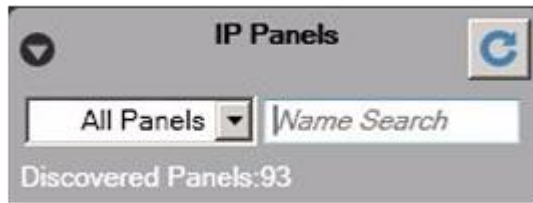

Figure 22-11 IP Panel Filter Options

- 9) To filter panels by status open the status menu (show as **All Panels**) and select the panel status filter.



Figure 22-12 Status Filter Menu

- 10) Select the required status filter to list all the panels in that state.

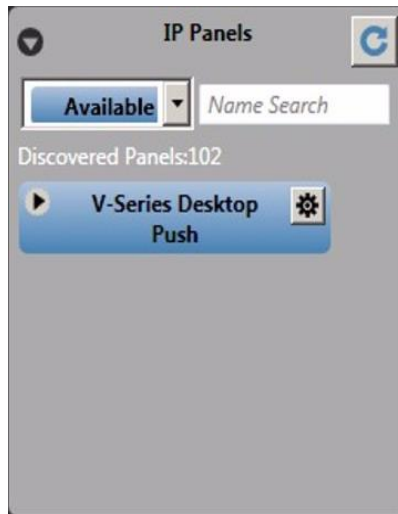

Figure 22-13 Panel Status Filtering

- 11) To filter panels by name enter the panel IP address, MAC address or panel ID into the **Name Search** box and click on the **Discover** button to refresh the display.

22.4 Assigning a panel to an IVC-32 port

- 1) To assign panels to ports on an IVC-32 card, drag the panel icon from the IP Panels pane to the assignment zone on the IVC-32 card. The following screen appears:

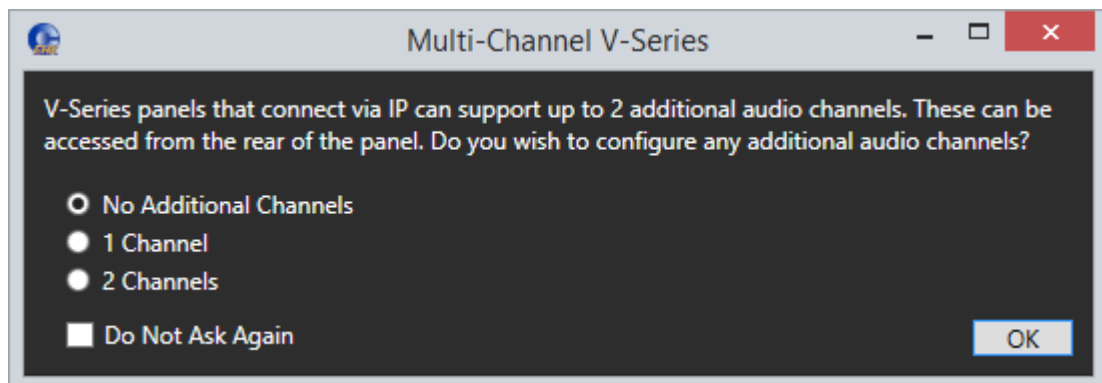

Figure 22-14 Multi channel V-series

Select the number of additional channels you require. If you select one or two additional channels, these channels automatically appear as **Hosted Direct** in the **Port Function** column of the **Cards and Ports** screen.

Panels can also be moved from one IVC-32 port to another. The results of the action depend on the status of the panel.

- Moving (assigning) a panel to a port on the IVC-32 card only adjusts the current user ID in the panel if no user ID in the panel currently exists. In this case a unique user ID is used as the user ID of the connection. The password on the connection is left blank. This initial state of the panel represented by the blue color and indicates that the panel is known to be out of use and ready for assignment.
- If a current user ID setting already exists on a panel it is not adjusted during an assignment. If the panel is used in another currently inactive Eclipse configuration this association would now have been broken.
- When a panel is not used by the current configuration but has a user ID (even though this may be a stale configuration) and the matrix IP address is in the current configuration, the panel is shown as red. Take care before using this panel, for example, check its current usage before assigning it
- If a panel's matrix IP address is not in the current configuration and a user ID is set the panel is shown as grey to indicate it is configured for use on another system. In this state only a user logged in as administrator (in EHX) may assign it to an IVC-32 in the currently active configuration.
- To un-assign a panel that has been assigned to a port on an IVC-32 card, simply drag the panel off the port and drop it in the blank area to the right of the IVC-32 cards.

22.5 IP cards

The IP Cards pane displays a list of all the IVC-32 cards detected in the current matrix with the number of the matrix slot the card is in.

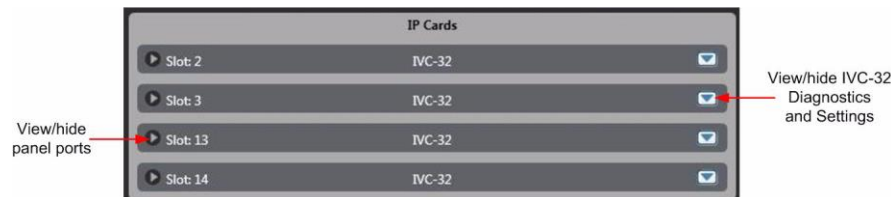

Figure 22-15 IVC-32 Cards List

- 1) To display diagnostics and the current card configuration, click the left menu button on any card. You can edit the card configuration.

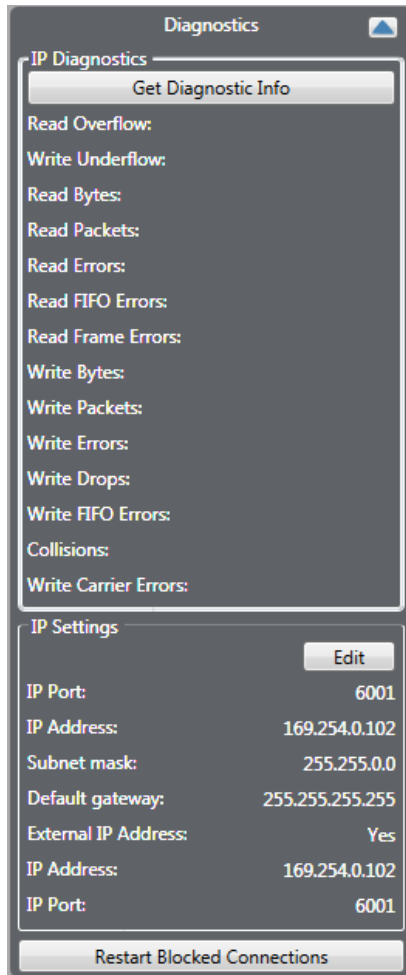

Figure 22-16 IVC-32 Cards Diagnostics and Settings

- 2) Click on the **Get Diagnostic Info** button to retrieve the current buffer overflow statistics. If a significant number of buffer overflows are reported this may indicate network problems.

22.6 IVC-32 IP settings

The IP Settings section displays the IP setup of the IVC-card.

- 1) To make changes, click on the Edit button. The fields change from grey text to input boxes. The external IP address and IP port are only enabled if the **External IP Address** box is checked.

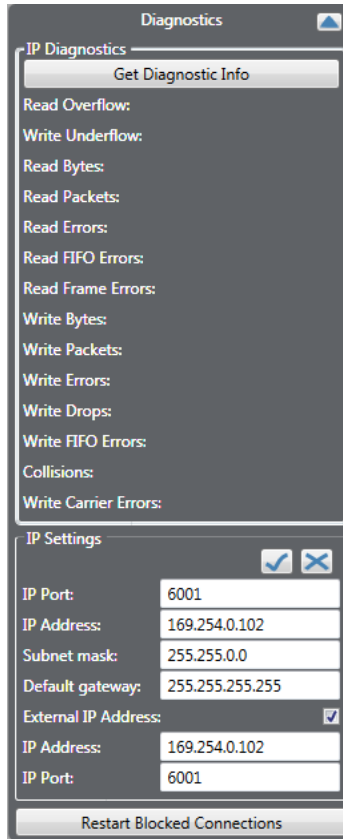

Figure 22-17 Editing IVC-32 Card Settings

22.6.1 IP port

The port the panel uses to log in to the IVC-32 card. This is the internal IP port if the panel is on the same LAN, or the external IP port if not.

This parameter should not normally be changed from the default value unless all the IP panels or Concert server are also updated to use the new port number. If this is not done the IP panels or Concert server cannot communicate with the IVC-32 card. Eclipse system administrators are advised to check with network administrators or IT that the default port may be used without causing a conflict with any other application on the network.

If the IP port number is changed ports 42001 and 1300 should not be used as these ports are already used by EHX. The Eclipse HX system administrator should check with the network administrator or IT to obtain a port number to use.

IP address

The IP address of the IVC-32 card that the panel tries to log in to. This is the internal IP address if the panel is on the same LAN, or the external IP address if not.

Subnet mask

Subnet mask used by the IVC-32 card to define the address range the card can access. Commonly set to 255.255.0.0 or 255.255.255.0.

Default gateway

The address of the gateway to be used to communicate with external devices such as IP panels and Concert clients over the IP network.

External IP address

Enable this checkbox to edit the external IP address and port number below the checkbox.

IP address

The external IP address that can be used to communicate directly with the IVC-32 card itself rather than the matrix via the IVC-32 card. This address is not used by IP panels etc.

IP port

The external IP port used when communicating directly with the IVC-32 card using the external IP address.

When the edits are complete click on the tick button to save the changes. Alternatively click on the cross button to discard the changes. As soon as the changes are confirmed EHX sends them to the IVC-32 card.

Restart blocked connections

The **Restart Blocked Connections** button at the bottom of the **Diagnostics** screen is used to restart a call initiated using IP directs and trunks. For more information, see section **25.2.7 IP directs and trunks**.

22.7 IVC-32 card panel list

- 1) To display a list of the panels connected to the IP ports on the IVC-32 card, click on the right button.



Figure 22-18 List of Ports on an IVC-32 Card

- 2) To display diagnostics for a panel, click on the down arrow button on the right side of the entry for the required panel.

This opens a diagnostics display of cumulative error data for the panel and the IVC-32 port it is connected to. Where data is presented for both panel and port this can be used to diagnose whether any network problems are at the matrix or panel end of the link.

- 3) Click **Get Diagnostic Info** to retrieve the current panel diagnostic data and display it.

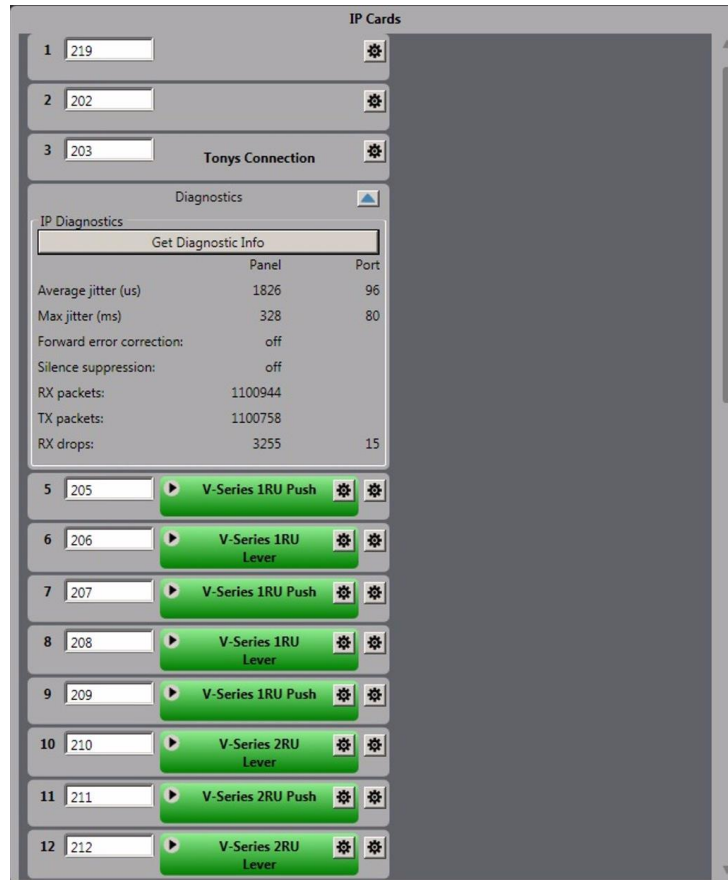

Figure 22-19 Panel Diagnostics Display

Jitter is a measure of the quality of the network connection. It represents the variation in the time period with which audio packets are received. For example, if an audio packet is expected every 10 milliseconds, but one audio packet is received 13 milliseconds after another, this represents a jitter of 3 milliseconds.

If the jitter gets too high the panel starts to experience audio dropouts.

WAN mode panels can deal with larger jitter than LAN mode panels, and Internet higher than WAN mode, as they use larger jitter buffers to smooth out the uneven arrival of audio packets. However the downside of this is that the larger the jitter buffer, the longer the audio delay.

- Average Jitter - the average packet interval in microseconds.
- Max Jitter - the highest packet interval measured in milliseconds.
 - LAN mode panels can cope with jitter up to 80 milliseconds without audio dropout.
 - WAN mode panels can cope with jitter up to 120 milliseconds without audio dropout.

- Internet mode panels can cope with jitter up to 200 milliseconds without audio dropout.
- Forward Error Correction - this allows the IVC-32 to recover from corruption in audio packets caused by a poor network link, at the cost of slightly increased network traffic and slightly higher audio delay. Forward Error Correction is set to a HIGH level in internet mode, LOW level in WAN mode and is disabled in LAN mode.
- Silence Suppression - this reduces the network traffic generated by a panel by stopping the transmission of packets when there is no audio input (that is, the microphone is turned off). It can cause a slight increase in audio delay. Silence suppression is enabled in WAN and Internet mode, but disabled in LAN mode.
- Rx Packets - this displays a count of the IP packets that a panel has received, and can be used to check the network connection. When Silence Suppression is enabled the numbers may only increase when the panel microphone is enabled.
- Tx Packets - this display a count of the IP packets that a panel has sent, and can be used to check the network connection. When Silence Suppression is enabled the numbers may only increase when the panel microphone is enabled.
- Rx Drops - The number of audio packets that have been lost. This can be due to network quality.

22.8 Concert users

The Concert Users pane obtains details of the Concert users on the specified Concert server. The user list can be obtained for all partitions on the server or for only one partition.



Figure 22-20 Initial Concert User Display

- 1) Click on the left hand button to enter or edit the IP address for the Concert server to be searched for users.



Figure 22-21 Current Concert Server IP Address

- 2) Click on the **Edit** button to enable the Concert server IP address for editing in order to input the correct address.

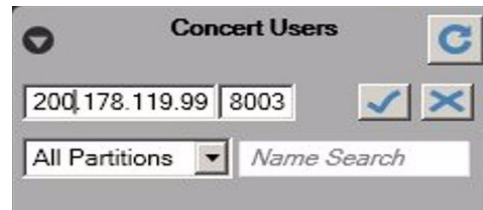

Figure 22-22 Editing the Concert Server Address

- 3) Enter the required address and optionally the port to be used. Normally the default port of 8003 should be accepted.
- 4) Click on the tick button to accept the edit or the cross button to cancel the edit.

Note: The port would not normally be changed unless there was a specific reason for this and the Concert server setup was also changed. If the port number is changed to an incorrect value IP Manager cannot connect to the server for the user information.

22.8.1 Concert server dialog

- 1) Click on the discover button (top right) to obtain the server information. If **All Partitions** is selected then all the Concert users known to the server are listed. Clicking on the down arrow next to **All Partition** displays a list of the partitions and allows a specific partition to be selected.

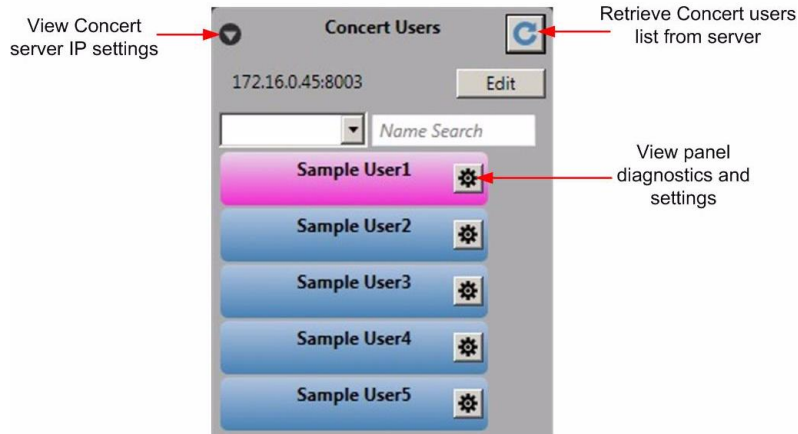

Figure 22-23 Concert Users on a Partition

The Concert users are color coded according to the user status. The possible user codes are described below.

- **Blue** - Concert user discovered, no configured login IP address or Eclipse ID or Password.
- **Amber** - Concert user discovered, configured in EHX to this configuration, but not logged in. This does not indicate whether or not it is configured in the matrix. The configuration of a port using the IP manager screen involves both the drag and drop in the UI and applying a map to the matrix.
- **Green** - Concert user discovered, user is logged in to this configuration.
- **Gray** - Concert user is discovered, login IP address set to the IP address of another matrix.
- **Red** - Concert user discovered, user is not in any of the previous categories, may be used by other configuration on same matrix IP address or not in use but setup on the current matrix.

Clicking on the arrow button on the right side of a user entry displays the user details and diagnostics.

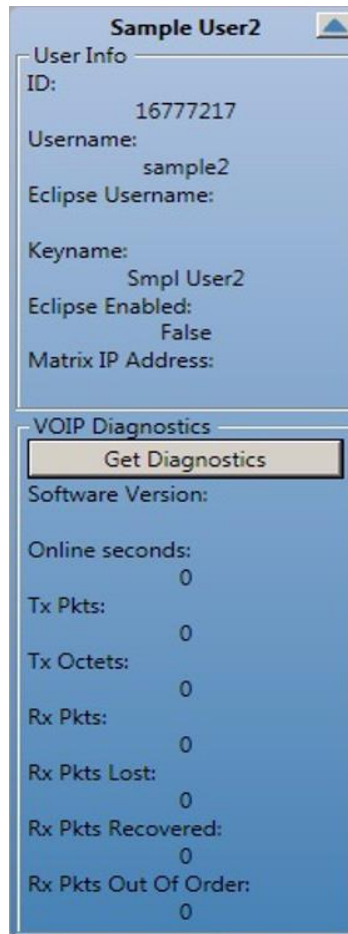

Figure 22-24 Concert User Information

The Concert user information fields provide the following details:

- ID - internal Concert identifier.
- Username - Concert user name.
- Eclipse Username - the name that is used to log in to the Eclipse / Eclipse HX system over IP. This is used in conjunction with the Concert panel. The Eclipse HX user name must be set up on the Eclipse HX system.
- Keyname - the name by which the Concert user is assigned to keys on Eclipse HX panels.
- Eclipse Enabled - whether the Concert user is allowed to log in to an Eclipse / Eclipse HX system.
- Matrix IP Address - the IP address of the matrix that the Concert user is logged in to when communicating with an Eclipse / Eclipse HX system.

Concert user diagnostics

The diagnostic display for Concert users indicates user activity.

- Software Version - the version of the Concert client in use. This field can only be displayed if the Concert user is logged in to the Concert server.
- Online seconds - length of time in seconds that the user has been online to the Concert server.
- Tx Pkts - number of Ethernet packets transmitted to the user Concert client.
- Tx Octets - number of 8-bit bytes transmitted.
- Rx Pkts - number of Ethernet packets received from the user Concert client.
- Rx Pkts Lost - number of Ethernet packets from the user client lost.
- Rx Pkts Recovered - number of lost receive packets recovered.
- Rx Pkts Out Of Order - number of Ethernet packets received from the user client in the wrong order.

The packet count diagnostics are to help diagnose network problems experienced by Concert clients such as excessive packet loss leading to lower audio quality.

22.8.2 Assigning a concert user to an IVC-32 port

- 1) To associate a Concert user with an IVC-32 port, drag and drop a Concert user entry onto a port on an IVC-32 card. If the port is already in use the current entry is removed and replaced by the Concert user. Concert clients can also be moved between ports on an IVC-32 card by dragging and dropping.

The IVC32 port's talk label, listen label and description fields are updated with the information received from the EMS (Concert) server.

The connection ID is set as follows:

- If the Concert User already has a connection ID this is assigned to that port, otherwise a new unique connection ID is created and used by both concert user and port. One special case is when the Eclipse ID is already in use, a new unique ID is created for both concert user and port.
- By default a connection password is NOT set. A password is only used if the port has a password explicitly set on it in Matrix Hardware for added security. The password can be set in **IP Panel Settings** under **Advanced Settings**.
- These changes are sent to the EMS server in real time during the drag and drop operation so no separate action is required to update the Concert server.

23 *Audio Mixer*

23.1 Introduction to Audio Mixer

The Audio Mixer facility is accessed from panel programming and is only available for V-Series panels. The Audio Mixer allows the audio input, output and crosspoint levels for the panel to be set by the use of the panel controls (main and auxiliary volume controls) or via the panel software. The audio mixer also allows audio input levels to be modified by means of threshold levels and compressors and for frequency based noise reduction filters to be applied. Crosspoints which are attached to IFB controls can also have the IFB dim levels set by the audio mixer.

The layout of the audio mixer is determined by the panel interface selected. For some types of interface such as the D25 connector more options are available than with the basic RJ45 interface.

When the pointer is moved over the panel, tooltips are displayed whenever it is over an active item such as a button on the toolbar, a filter setting or a crosspoint. The tooltip displays the current setting of any audio processing element.

23.2 Audio Mixer panel

The audio mixer panel is divided into three functional areas, Input, Crosspoint and Output. Each area has separate controls that function independently of controls in other areas. For example the controls in the input area act on the input audio stream before it passes to the crosspoints.

The audio mixer areas are shown in Figure 23-1 Audio Mixer Panel below.

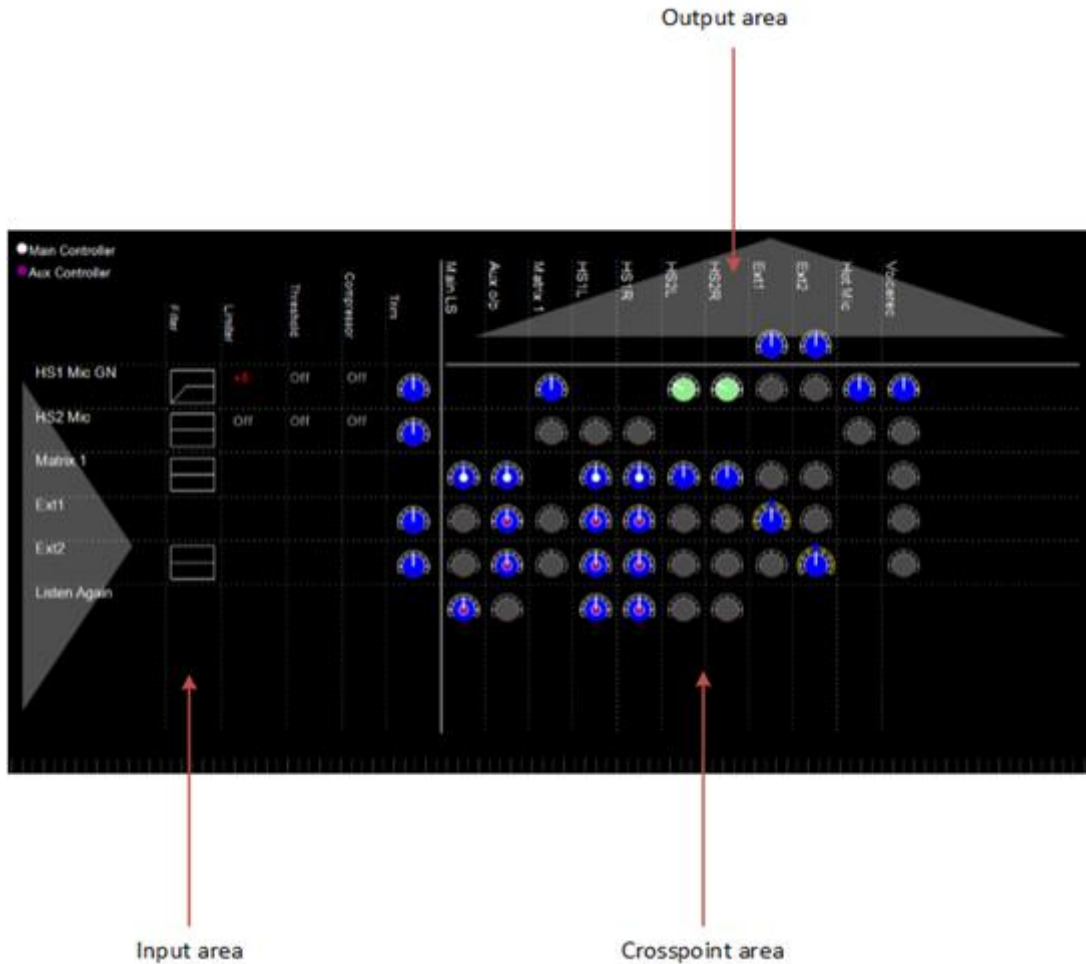

Figure 23-1 Audio Mixer Panel

The audio mixer toolbar provides facilities to apply, save or configure the audio mixer.

Note: For multi-channel V-Series Panels the labels of the Hosted Directs will appear on the audio mixer if they are available.

23.2.1 Save to EHX configuration and exit

- 1) Click on this button to save the audio mixer setup to the current EHX configuration. When in Go Live, mode clicking on this button also saves the audio mixer settings into the current EHX configuration. After the setup has been saved the audio mixer automatically exits back to panel programming.
- 2) Click on this button to allow audio mixer settings to be sent to the panel immediately without the need to save to the configuration and apply a new map.

When the Live mode button is pressed it flashes amber/green and the mixer pane background changes to amber while EHX contacts the matrix and uploads the current audio settings for the selected panel. If the button and audio mixer pane background remain amber (see **Figure 23-2 Live Mode Waiting for Reply** below) this indicates that EHX was unable to obtain the current panel audio settings from the matrix (the panel may not be connected to the matrix).

It may take a few seconds for EHX to obtain the panel details from the matrix.

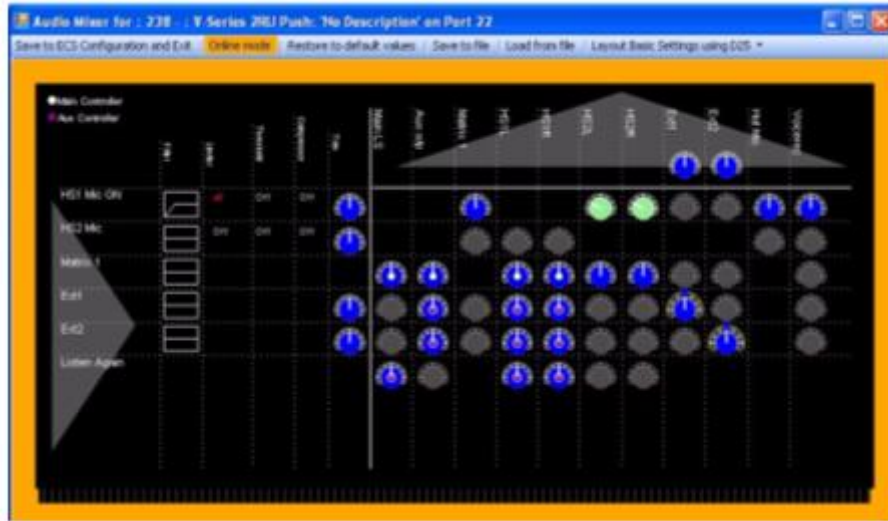

Figure 23-2 Live Mode Waiting for Reply

When the settings have been loaded the button and audio mixer pane background turns green to indicate that the settings may be adjusted (see **Figure 23-3 Live Mode Connected and Ready**).



Figure 23-3 Live Mode Connected and Ready

Whenever a setting is changed in Live mode it is sent to the matrix to be applied to the panel and a confirmation is returned. While EHX is waiting for confirmation

that the change has been applied the Live mode button changes to amber and then to green when confirmation is received.

23.2.2 Restore to default values

Click on this button to reset all the mixer settings for the current layout to their default values. The user is asked to confirm the request. Click on **Yes** to replace the current settings with the default settings or **No** to cancel the action. This option can also be used when in Live mode.

23.2.3 Save to file

Click on this button to save the audio mixer settings to a file. The file save dialog requests a file name. If no filename extension is given it defaults to `.amc`. This feature is available when in Live mode.

23.2.4 Load from file

Click on this button to load audio mixer settings from a file previously created by the file save function. If this function is used in Live mode the settings in the file is sent straight to the panel.

23.2.5 Layout settings

Click on this button to display a drop-down menu of layout options. These options configure the audio mixer for V-Series panels that have their audio connected in different ways such as the Matrix port, the 25-way D-type auxiliary audio and the AES3 interface.

Note: The layout cannot be changed while in Live mode.

Layout basic settings

This configures the audio mixer for the panel when using the matrix RJ-45 analog matrix connection.

Layout basic settings using D25

This configures the audio mixer for use with the analog RJ-45 and auxiliary audio connectors.

Layout binaural coax/AES

This configures the audio mixer for use with the AES3 digital option card. The AES3 option card has both RJ-45 and coax connectors and auto-detects which is in use. This option applies regardless of which connection on the AES3 card is used.

Layout binaural coax/AES using D25

This configures the audio mixer for use with the AES3 digital option card and the auxiliary audio connector or front headset (XLR-5 or XLR-7). The AES3 option card

has both RJ-45 and coax connectors and auto-detects which is in use. This option applies regardless of which connection on the AES3 card is used.

IP Basic

This configures the audio mixer for use with the Ethernet connector.

IP One Sub-Channel

This configures the audio mixer for use with one additional IP channel.

IP Two Sub-Channels

This configures the audio mixer for use with two additional IP channels.

IP with Binaural

This configures the audio mixer for use with a binaural headset using the front headset (XLR-5 or XLR-7) or rear Headset #2 connector.

23.2.6 Input area

This area contains a list of all the available audio sources and five columns for processes that can be applied to the audio before it is sent to the crosspoint audio mixers. Any processing applied at this point affects the audio supplied to all the downstream mixing.

Audio inputs

The first column in the input area lists all the inputs that may be available in the configuration. All of the possible inputs are listed below but some inputs may not be available depending on which input/output interface options have been selected.

HS1 Mic GN

This input takes audio from the headset1 microphone or gooseneck microphone.

HS2 Mic

This input takes audio from the headset2 microphone.

Matrix1

This input takes mono audio from the analog matrix connection if the Basic Layout is being used or one channel of stereo audio from the AES3 digital option card if this is fitted.

Matrix2

This input takes a second channel of stereo audio from the AES3 digital option card. This input is only available if the AES3 digital option is fitted.

Ext0

This is the port labelled as Matrix (Analog) and can be used as a local analog port when in IP mode

Ext1

This input uses the External Input 1 on the auxiliary audio connector.

Ext2

This input uses the External Input 2 on the auxiliary audio connector.

Listen again

This input uses audio from the listen again facility.

Filter

The filter column shows a graphic representing the type of audio filtering that is being applied to the audio inputs. The graphic represents the frequency profile of the input filters.

Output area

The top row of the output area lists all the outputs that may be available in the configuration. All of the possible outputs are listed below but some outputs may not be available in specific configurations.

Main LS

This outputs audio to the main panel loudspeaker.

Aux o/p

This outputs audio to the auxiliary loudspeaker via the auxiliary audio connector.

Matrix1

This output sends either mono audio to the matrix via the analog matrix connection or one channel of stereo audio to the matrix via the AES3 digital connection.

Matrix2

This output sends one channel of stereo audio to the matrix via the AES3 digital matrix connection. It is also present if there are additional IP channels configured on an IP-enabled V-Series panel.

Matrix3

This is present if there are an additional 2 IP channels configured on an IP-enabled V-Series panel.

HS1L

This output sends audio to the main panel headset left ear.

HS1R

This output sends audio to the main panel headset right ear.

HS2L

This output sends audio to the second headset left ear via the auxiliary audio connector.

HS2R

This output sends audio to the second headset right ear via the auxiliary audio connector.

Ext1

This sends audio output to the first external output via the auxiliary audio connector.

Ext2

This sends audio output to the second external output via the auxiliary audio connector.

Hot Mic

This sends audio output to the hot mic output via the auxiliary audio connector.

Voicerec

This output sends audio to the Listen Again voice recording facility.

Filter settings

The filters are applied to input audio streams to remove extraneous noise from the audio before it is sent to the mixer. There are two types of filter; the Low Pass filter and the High Pass filter.

The Low Pass filter passes low frequencies and is used to remove high frequency noise such as wind noise while the High Pass filter passes high frequencies and is used to remove low frequency noise such as machinery.

Each filter has four possible settings: off, filter 1, filter 2 and filter 3.

- Off - no noise filtering is done.
- Filter 1 - uses the first noise filtering algorithm.
- Filter 2 - uses the second noise filtering algorithm.
- Filter 3 - uses the third noise filtering algorithm

The frequency filters have the following effects:

High Pass 1 - reduces audio volume below 120Hz.

High Pass 2 - reduces audio volume below 250Hz

High Pass 3 - reduces audio volume below 500Hz

Low Pass 1 - reduces audio volume above 8KHz

Low Pass 2 - reduces audio volume above 12KHz

Low Pass 3 - reduces audio volume above 15KHz

The filter configuration is shown using a graphic of the frequency against level.

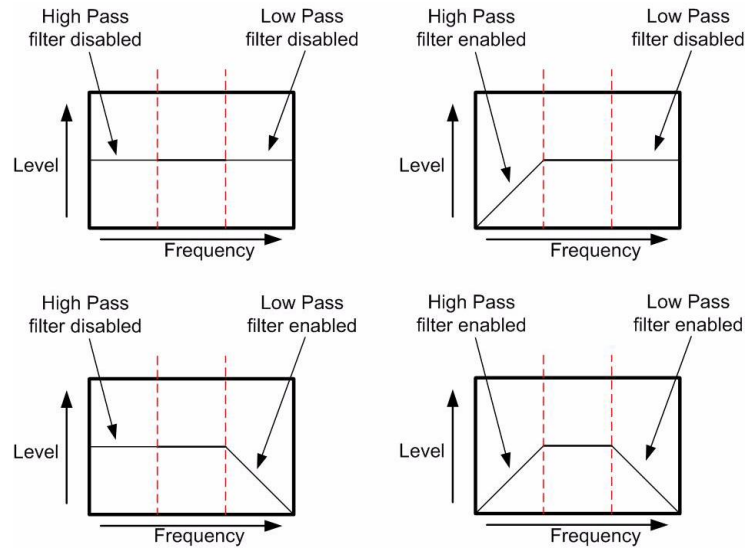

Figure 23-4 Audio Mixer Filter Settings

If the mouse pointer is placed over the filter graphic a tooltip is displayed giving additional information on the filter settings.

Limiter/threshold/compressor

These settings are all linked together and provide a facility for controlling the overall level of the input audio. The settings allow the audio level to be limited to a maximum and audio above a threshold level to be modified as it approaches the maximum permissible level.

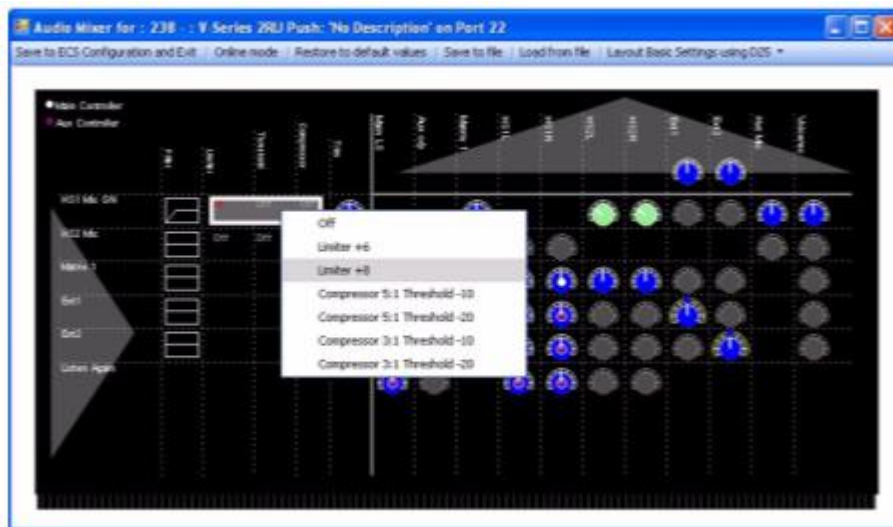

Figure 23-5 Audio Level Compression

Limiter

This sets the maximum audio level on the input that is passed to further stages of the audio mixer. The limiter settings are:

- Off
- -6dB
- -8db

Threshold

The threshold setting determines the level at which audio compression starts. When the audio input level passes the threshold, it begins to be compressed so that the output level from the compressor approaches the audio limit more slowly as the audio input level rises. The threshold settings are:

- Off
- -10dB
- -20dB

Compressor

The audio compressor reduces the audio level by compressing it whenever the audio level exceeds the threshold. This has the effect of allowing the audio level to rise but reducing it by a fixed ratio. The compressor settings are:

- Off
- Compression 5:1
- Compression 3:1

For example, if the compressor is set to 5:1 with a threshold of -10dB this has the effect that for every 5dB increase in the input level above the threshold of -10dB the compressor outputs only 1dB of increase. So, if the input audio is 20dB above the threshold the output from the compressor only shows an increase of 4dB. If the limiter was set to +6dB then a 20dB increase would normally exceed the limiter (10dB + 20dB = 10dB) so the audio level would be cut off at +6dB. With the compressor, the audio level would not reach the limit so the audio would still rise to mimic the input (-10dB + 4dB = -6dB).

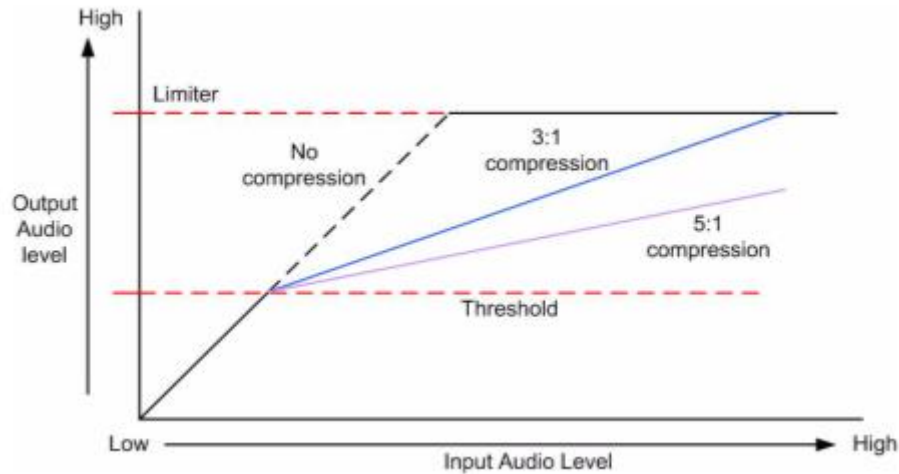

Figure 23-6 Audio Compression

Input trim

The input trim sets the amount by which the output from the filter and compressor is modified before it is fed to the audio crosspoints. It is displayed as a color-coded dial indicating the trim action. To set the trim right click over the dial to display the list of preset trim levels.

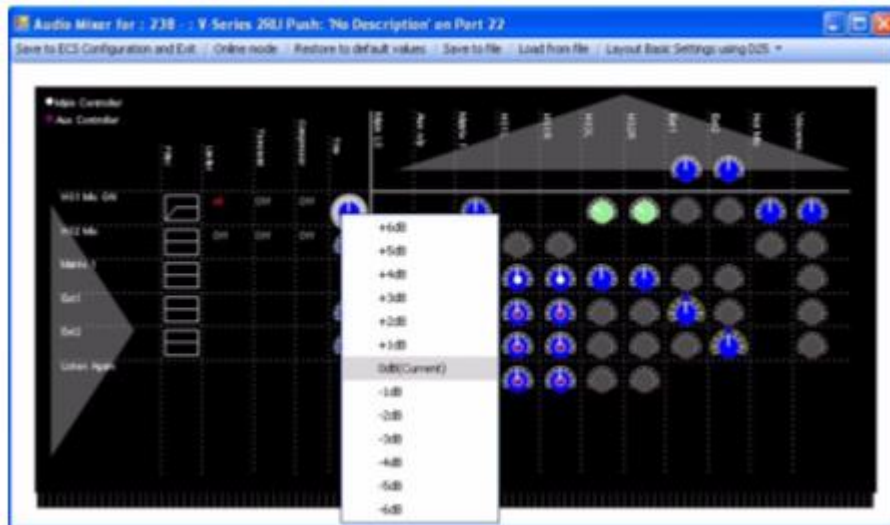

Figure 23-7 Input Trim

If the dial is colored blue, then no trim (0dB) is being applied. If the dial is green, then a negative trim is being applied to reduce the audio level. If the dial is red, then a positive trim is being applied to increase the audio level.

23.2.7 Crosspoints

The crosspoint area of the audio mixer displays all the crosspoints available for the current configuration and the status of the crosspoint.

Each crosspoint allows individual setting of the input and output audio between the audio source in the input section and the Asia destination in the output section. Each crosspoint is displayed as a dial with color coding to show the status of the crosspoint. The color codes are:

- Grey - crosspoint is muted so no audio passes through the crosspoint.
- Blue - audio level gain is set to 0dB or controlled by a volume knob.
- Green - audio level is reduced in the crosspoint (gain level is negative for example, -3dB).
- Red - audio level is increased in the crosspoint (gain level is positive for example, +3dB).
- Blank - no crosspoint.

The center of the dial is also color coded when appropriate to indicate whether the audio level is being controlled by software only or by the panel volume controls. The settings are:

No colored center - audio levels are set in software only.

White center - audio level is set by main volume control knob.

Mauve center - audio level is set by auxiliary volume control knob.

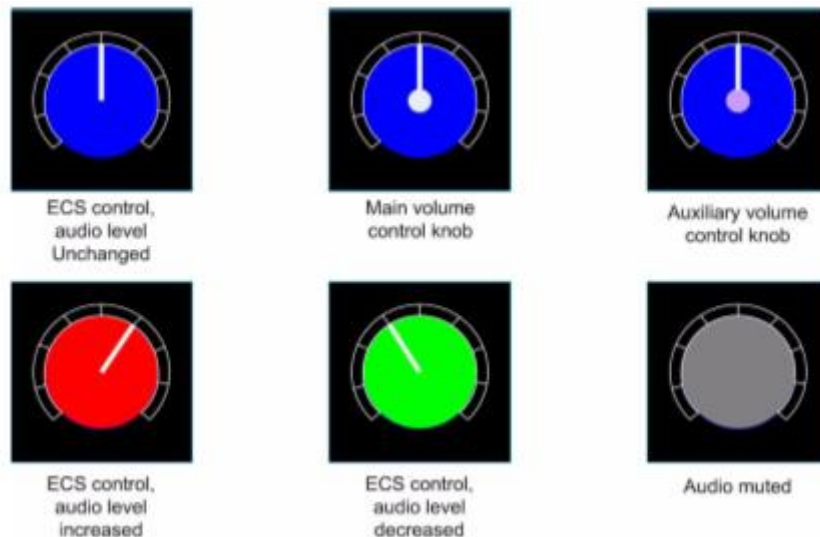

Figure 23-8 Audio Mixer Crosspoint

Right clicking on a crosspoint dial displays a list of options for setting the crosspoint.

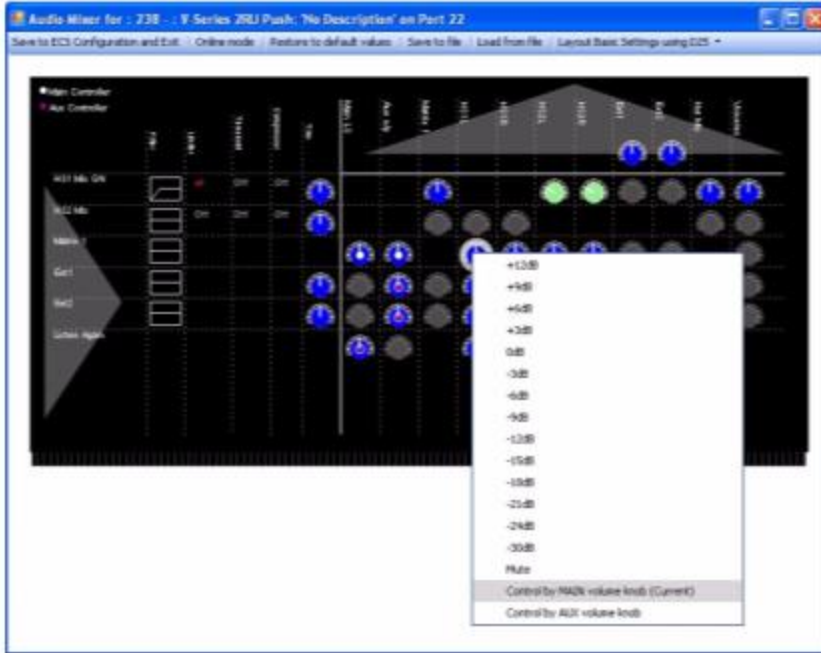
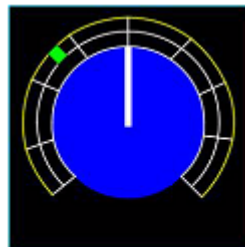

Figure 23-9 Crosspoint Settings

If an additional yellow ring is displayed on the crosspoint dial this indicates that the crosspoint is also used by locally generated panel IFBs. If the panel IFB is activated the audio output from the crosspoint mixer is reduced (dimmed) by the specified amount.



Audio level with
IFB mute set

Figure 23-10 Crosspoint with IFB

The colored segment in the outer dial indicates the dim setting for the IFB (the amount by which the source audio is dimmed when the IFB control is activated). This is set by right-clicking on the dial and selecting the required IFB level. The panel IFB is activated using a control set up in Control Manager.

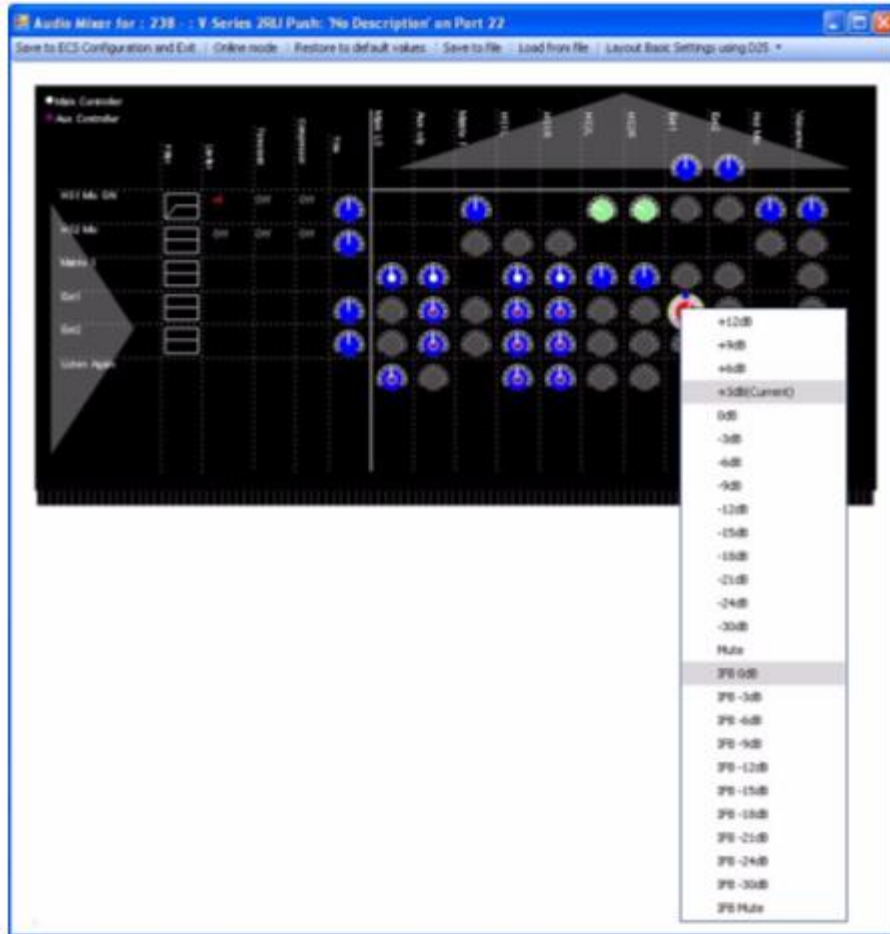

Figure 23-11 Setting IFB Dim on Crosspoint

The level settings from +12dB to -30dB represent the levels set for audio through the crosspoint, and Mute stops all audio through the crosspoint. Below this are the IFB dim levels from 0dB to -30dB and Mute (IFB completely interrupts audio feed).

Setting Up V-series panel audio mixing IFBs in imported configurations

When a EHX 4.2 map is imported the IFB control information V-Series panels is lost due to changes in the way the configuration data is organized. To restore the IFBs and restore the control information:

- 1) Open Panel Programming from the Configuration menu.
- 2) Select the V-Series panel that the IFB control was originally attached to.
- 3) Open the audio mixer.
- 4) Use the audio mixer to set the IFB dimming for EXT1 and EXT2 crosspoints as required. This action creates Panel IFB relays IFB1 and IFB2 for that panel.

- 5) Close the audio mixer.
- 6) Open the Control Manager.
- 7) Select the **Panel IFB relays** tab. The available IFBs are displayed.
- 8) Select a control or create a new control.
- 9) Use the control manager to attach the IFB to the control.
- 10) Close the control manager.
- 11) In panel programming the control is now available under the **Controls** tab to be assigned to a key on the panel in the normal way.

23.2.8 Output area

The output area contains trim controllers for individual outputs displayed as dials. When these are set whatever audio is being sent to the output is changed by the specified amount. As before right clicking the dial displays the audio settings available for that output. The dials are color coded to indicate the trim applied as described for the crosspoint.

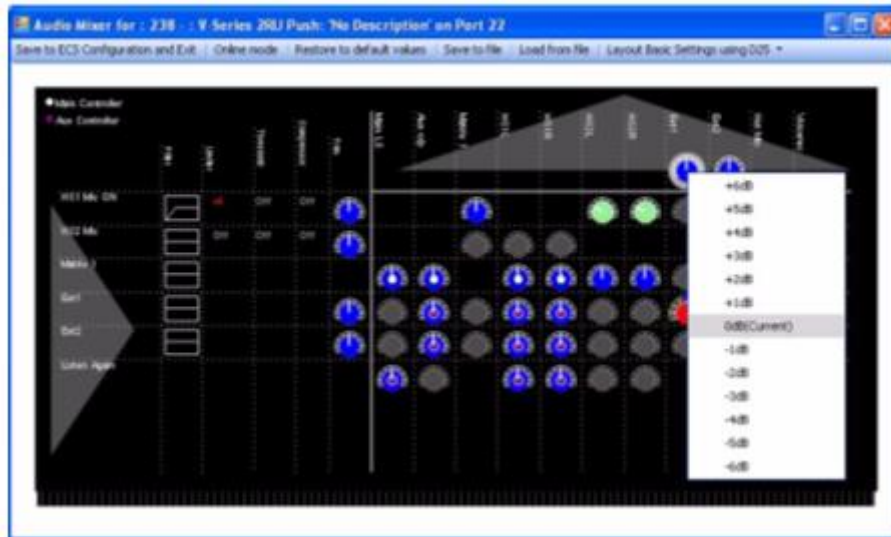

Figure 23-12 Output Settings

24 Go Live mode

24.1 Introduction to Go Live mode

Go Live mode is a mode that allows changes to be made to the configuration of a live system without the need to apply a new configuration. The new configuration is held in the matrix and even if the matrix is reset the modified configuration is preserved rather than defaulting back to the original configuration map.

Note: This feature used to be called **Online mode**.

The changes are not automatically added to the system configuration controlled by EHX until the modified configuration is saved either by clicking on the Save' button in the File menu on exiting Go Live mode, by applying a map to the matrix or by exiting EHX and selecting **Yes** to save the configuration.

Go Live mode allows:

- The labels on a key (including beltpacks) to be added, deleted or moved in Panel Programming.
- Forced Listen and Blocked Listens to be updated in Local Advanced.

The functions which can be used in Go Live mode are indicated by **green** color-coding of the menu entries and button text.

However, there is an important limitation when using Go Live mode on linked systems. If a label refers to a source or destination on a remote matrix (a matrix linked to the current matrix) it cannot be assigned in Go Live mode unless it is already present in the current map being modified. For such a label to be present in a configuration it must have been assigned at least once and then applied as part of a map.

So, it is recognized by the matrix if it is assigned in Go Live mode. Local sources and destinations (on the current matrix) can be assigned for the first time in Go Live mode provided they have already been set up in the current map. For example, a local Party Line cannot be created in Go Live mode but it can be assigned to a key for the first time in Go Live mode.

If a remote source or destination is assigned to a key for the first time in Go Live mode, the label is initially displayed in the panel mimic and then disappear because the matrix rejects the assignment request. Further information on this limitation is given later in this chapter.

Go Live mode operates in a completely live mode so that as soon as a change is made in EHX the configuration in the matrix is updated. If a label on a key is changed for example, the panel affected is updated without any further user intervention.

EHX is notified of any changes that are made live, so if EHX is running on any other PC which is also configuring the same matrix and in Go Live mode it is also updated with the changes. Therefore, it is possible for more than one EHX to be

editing a configuration with each change being displayed on all the copies of EHX connected and in Go Live mode. However, this mode of operation is not recommended due to the risk of the different copies of the configuration diverging later if one of the instances of EHX ceases to be online.

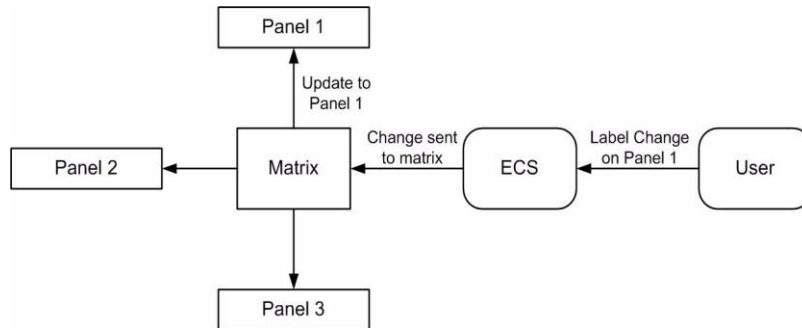

Figure 24-1 Live Update Sequence

24.2 Entering Go Live mode

- 1) Select **System > Go Live** to open a drop-down menu of Go Live mode options.

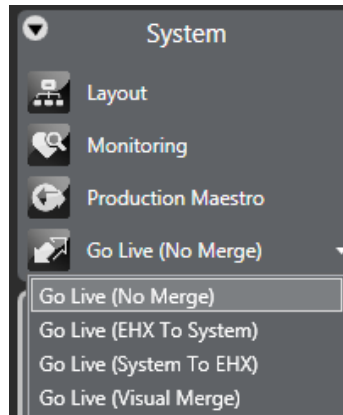

Figure 24-2 Go Live Mode Options

The live modes have the following effects:

- Go Live (No Merge) - go live without merging the current EHX configuration with the current matrix configuration.
- Go Live (EHX To System) - merge the current EHX configuration down to the matrix; the EHX configuration takes precedence.
- Go Live (System To EHX) - merge the current matrix configuration up to EHX. The matrix configuration takes precedence.
- Go Live (Visual Merge) - merge the configurations and offer the operator the option to decide which configuration takes precedence in the event of a conflict.

If the name of the configuration on the matrix is different to the configuration currently open in EHX, Live mode displays an error message.

The user may continue with the operation by clicking on the **Yes** button but it is generally not advisable. If the user does continue with the operation further errors may be reported.

EHX then compares the matrix configuration with the current EHX configuration. If inconsistencies are found between the current configuration in EHX and the information from the matrix infromatory messages are displayed.

EHX displays any differences between the current configuration open in EHX and the information from the matrix. For example, if a key is present on a panel in the EHX configuration but not in the matrix configuration then it be reported as a difference.

The same approach applies to forced and blocked listens.

Beltpacks and panels attached to the matrix that are offline or disconnected are not considered when EHX is checking for differences between the matrix configuration and the EHX configuration.

The user is given the following options if the configurations cannot be merged:

- Upload **On Matrix** into EHX - overwrite the configuration in EHX with the current matrix configuration.
- Download **In EHX** to matrix - overwrite the configuration in the matrix with the current EHX configuration.
- Export - export the Go Live mode error report as a text file for analysis.
- Cancel - Cancel the live operation and exit Go Live mode.

Some conditions can cause the live merge to report errors. The most common conditions are:

- Panels present in the EHX configuration but not in the matrix configuration.
- Panels present on the matrix but not in the EHX configuration.
- Panels with locally assigned keys that are different to the keys set up in the EHX configuration.

In general merge errors arise when there are mismatches in the configuration through offline assignments in EHX or live assignments through a panel. The live error report that can be exported from EHX should be used to resolve conflicts if it is not desirable to overwrite either the EHX configuration or the matrix configuration.

If the matrix configuration appears to merge without errors being reported but there are apparent changes in areas such as panel programming the user should check whether the map in EHX has been imported but not applied before entering Go Live mode.

Once the configurations have been synchronized the background on the menu pane turns **green** and live editing of panel setups may be carried out. The Go Live button now displays Go Offline.

24.3 Using Go Live mode

In the example below keys are assigned to a panel in Go Live mode to take immediate effect.

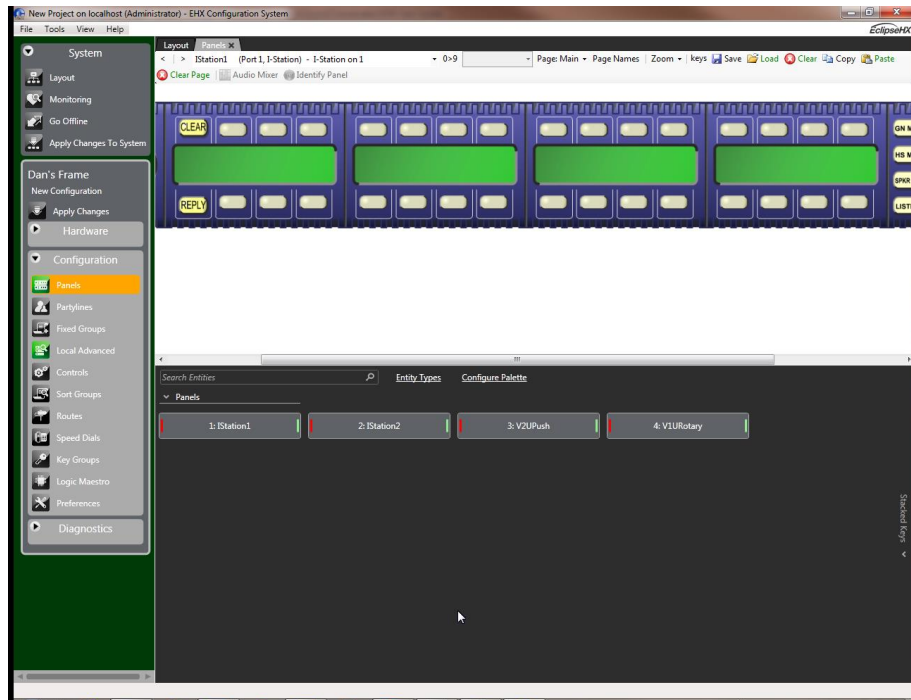

Figure 24-3 Panel Programming Display with Go Live Active

If the keys are changed on this panel the changes are sent to the matrix and then on to the panel. The matrix returns a confirmation to EHX that the panel has been updated.

Forced and blocked listens on crosspoints in Local Advanced can also be set or cleared using Go Live mode. It should be noted that the Forced Listens shown in Local Advanced can be IFB sources.

As with panel labels these changes take immediate effect.

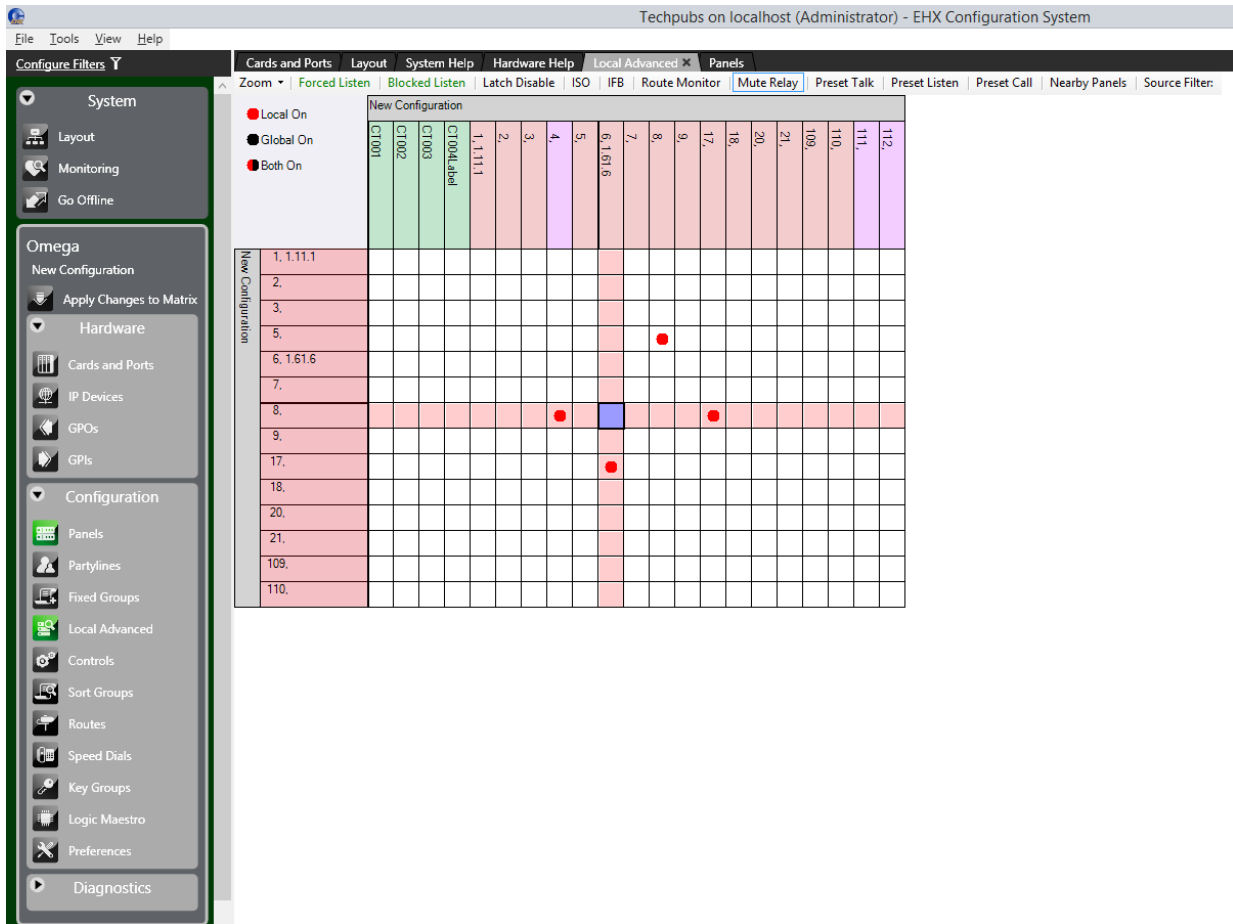

Figure 24-4 Local Advanced Display with Go Live Active

24.4 Go Live limitations

Go Live mode provides much of the functionality of Panel Programming but it cannot be used to create new entities. This must be done in EHX. Specifically Go Live mode cannot:

- Create or edit a Party Line.
- Create or edit a Fixed Group.
- Create or edit a Control.
- Create a Talk and Forced Listen key.
- Create the first remote key to a Fixed Group.
- Create the first remote key to a Party Line.
- Create the first remote key to a Control.
- Create a stacked key.
- Create or edit an IFB.

Also, as noted previously Go Live cannot assign a label that refers to a remote system unless it is already present in the current map. For such a label to be present in a configuration it must have been assigned at least once and then applied as part of a map. In this way it is recognized by the matrix if it is assigned in Go Live mode.

24.5 Exiting Go Live mode

- 1) To exit Go Live mode, click **Exit Live Mode**.

The background color of the menu pane returns to gray. The button text changes to **Go Live**.

At this point the configuration on EHX and on the matrix should be synchronized but the configuration is not saved in the database at this point. The configuration on the matrix is preserved in non-volatile memory in the event of a power failure but it is lost if a new configuration is applied. Therefore it is highly recommended that after a configuration is updated in Go Live mode it should be saved in EHX either to the current project or as a new project to ensure that the changes are preserved.

Go Live mode can also be ended as a result of other actions that force EHX out of this Go Live mode.

Possible actions include:

- Changing to a different configuration while live. This action causes EHX to drop the connection to the matrix.
- Closing the current project without exiting Go Live mode first.
- Selecting **Apply Map to Matrix** to apply a new map to the matrix.
- A physical reset of the matrix. In this case as well as dropping Go Live mode the background of the menu pane turns red to indicate that the connection to the matrix has been lost.
- Loss of the Ethernet connection to the matrix. As with a reset the menu pane background changes to red to indicate that the connection has been lost.

25 Networking

25.1 Network system configuration

Using the layout pane, you can create, delete, or edit matrices for a particular matrix system. You can also allocate configurations to Eclipse HX matrices, clear configurations and retrieve active current configurations.

The layout screen also allows you to manage Intelligent Linking Trunks. For more information, see section **25.2 Intelligent linking (trunking)**.

25.1.1 Configuration passwords

Individual configurations can be password protected to prevent unintended or unauthorized changes to be made or the configuration to be applied to a matrix.

- 1) To set the password on the current configuration right-click the matrix on the layout pane, and select **Configuration > Configuration Manager**.

When the Configuration Manager is open the properties of any of the available configurations (on that matrix) can be viewed and edited.

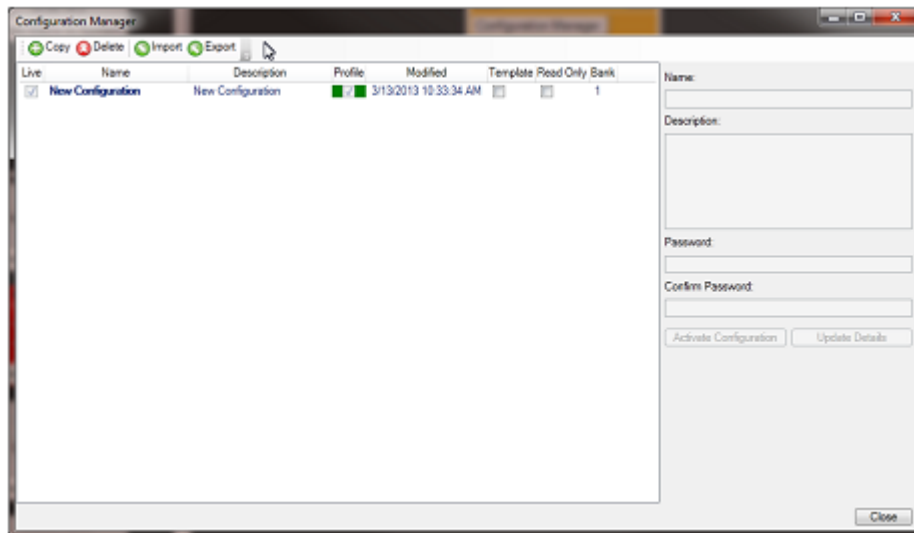

Figure 25-1 Configuration Properties Dialog

- 2) To set or change the password for a configuration type the password into the Password field and then retype in the **Confirm password** field. Then click on the **Update Details** to add the password to the configuration. The configuration must be saved and closed before the password becomes operative.

EHX users with Admin rights can always open a configuration regardless of whether a password has been set and reset the password if required. If an EHX user without Admin rights opens a password protected configuration they are asked for the password.



Figure 25-2 Configuration Password Entry

The correct password must be entered to open the configuration. Once the configuration has been opened by an EHX user with User rights that user may then change or remove the password.

The configuration password may be removed by opening the configuration properties and clearing both the **Password** and **Confirm password** fields and then saving the configuration. The next time the configuration is opened it is no longer password protected.

25.1.2 Using the layout pane

The layout pane is accessed from the EHX menu pane. Below is a description of each option.

The commands available to the user depend on whether the user has Admin rights.

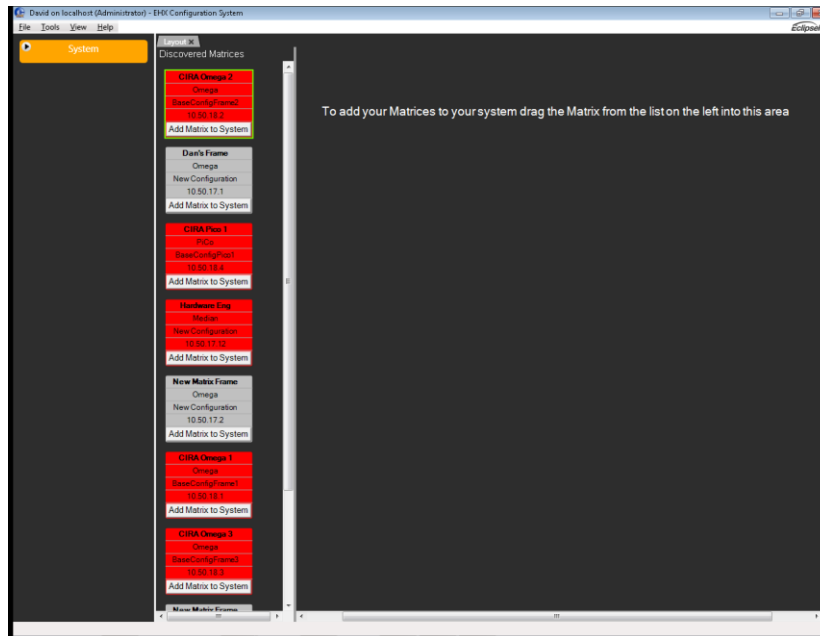

Figure 25-3 System Screen

Matrix status

The matrix icons in the layout pane are colored according to the status of the matrices:

- **Amber** - the EHX configuration is not the same as the current matrix configuration.
- **Red** - wrong firmware on matrix for current version of EHX.
- **Grey** - matrix unavailable or already connected to EHX.
- **Green** - matrix is connected and available.

Protocols and port numbers

The Eclipse HX system components (matrix and EHX) communicate using UDP and TCP protocols.

Rack to rack

The volume of traffic both exchanged rack to rack and rack to/from EHX is not large, there are however of course some points when this is at a peak. The racks use both directed and broadcast UDP traffic to communicate.

Broadcast: UDP Port 42001

Directed: UDP Port 42001

Rack to EHX

UDP Port 1300

TCP Port 52001 to TCP Port 52020 inclusive (Lifetime of out of sequence packets 1 sec).

25.1.3 Allocating a configuration to a matrix

To allocate a configuration to a matrix:

- 1) Select the matrix by clicking over the matrix icon on the layout pane. The matrix is highlighted with a green border.
- 2) Click **Tools > Configuration Bank** on the EHX toolbar to open the menu listing the configuration slots available (normally four). Select the bank for the configuration.
- 3) Right-click the matrix to open the menu and select **Configuration > Configuration Manager**.
- 4) In **Configuration Manager**, select the configuration to be applied to the matrix and then click on the **Activate** button to apply the configuration to the matrix.

- 5) Close the **Configuration Manager**. The name of the selected configuration is displayed on the matrix.

25.1.4 Deleting a matrix from the project

To delete a matrix from the layout pane:

- 1) Right-click the matrix.
- 2) From the context menu, select **Delete Matrix from Project**.
The matrix is deleted from the current project and removed from the layout pane.

25.1.5 Retrieving the last applied configuration from the matrix

To retrieve the last applied configuration from the matrix:

- 1) Right-click on the matrix.
- 2) From the context menu, select **Configuration > Retrieve Map from Matrix**. The following message appears:

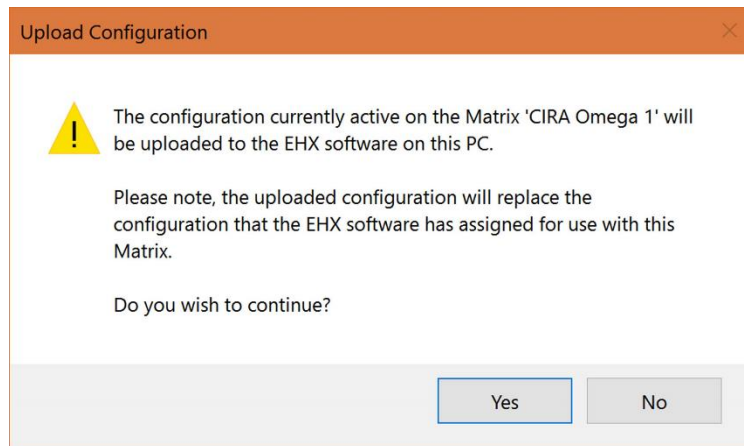

Figure 25-4 Upload configuration

- 3) Click **Yes** to continue. A confirmation message appears.

Note: The Retrieve Configuration functionality is not available over a serial connection between the Eclipse HX matrix and the EHX PC.

25.1.6 Exporting a binary downloadable version of the configuration file

You can download a binary version of the matrix configuration file with applications that use the HCI interface software. To do so:

- 1) From **System Layout**, click **Configuration Manager** on the Matrix icon

The Configuration Manager screen appears.

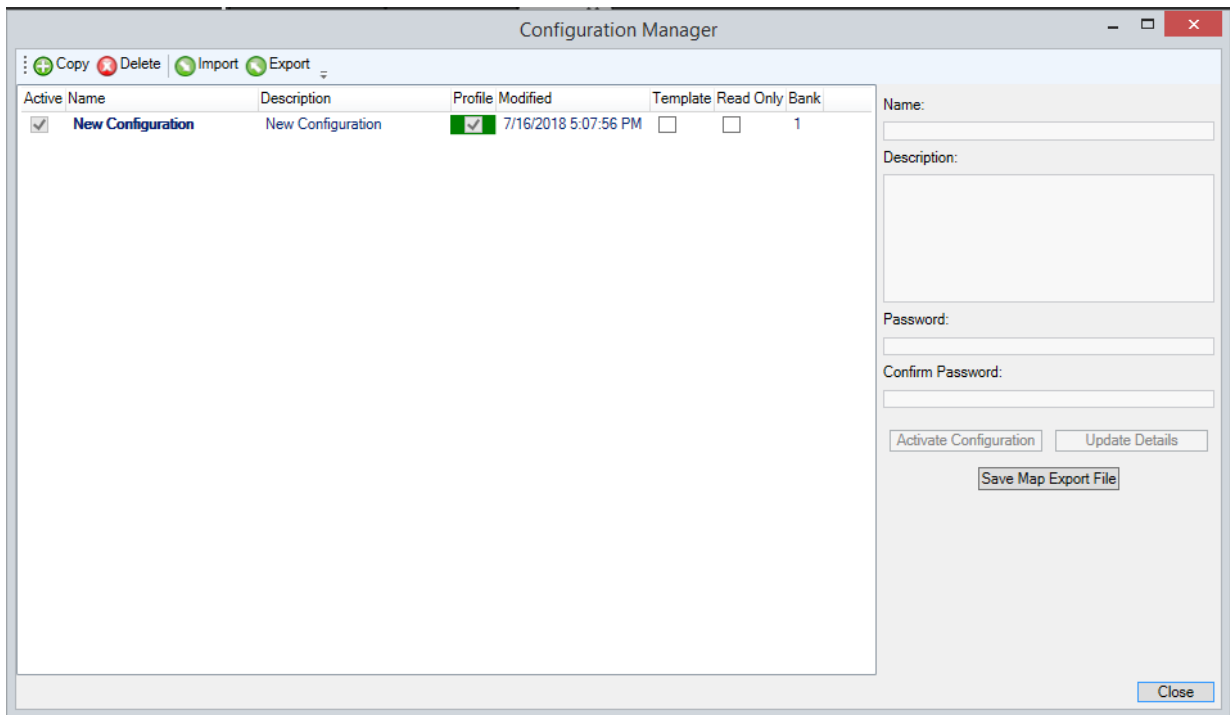

- 2) Click **Save Map Export File**.
- 3) Select a location to store the file.

For more information, see the *HCI Reference User Guide*.

25.2 Intelligent linking (trunking)

As many as 64 separate Eclipse HX-Omega, Eclipse HX-Median, Eclipse HX-Delta and Eclipse HX-PiCo system matrices can be intelligently linked, using dedicated audio trunk lines and an Ethernet network. Audio travels between the matrices on the dedicated trunk lines, while control data travels on the Ethernet network.

When intelligent linking is enabled, multiple sources from one matrix are mixed on one or more trunks that connect to the destination matrix. When intelligent linking is not enabled, multiple sources from one matrix are never mixed on trunks. Any mixing of audio takes place only on the destination matrix.

You can intelligently link Eclipse HX matrices using:

- Fiber-optic connections (using E-FIB fiber cards).
- Four-wire connections (using MVX-A16 analog cards).
- E1/T1 connections (using E-QUE cards).
- MADi connections (using E-MADI64 cards). When using E-MADI64 cards, ensure that Trunk Port 1 on the first card is connected to Trunk Port 1 on the second card, and similarly for Trunk Port 2.

- IP trunks/directs between two IVC-32 cards in separate matrices (see section **10.5.1 Parent port**).
- IP to 4-wire trunks using IVC-32 cards and LQ devices.
- IP trunk/direct between E-Dante cards on separate matrices (use E-Dante64-HX cards and Dante controller to set up connections).

Note: Fiber, E1/T1, MADI, DANTE and IP trunks/directs linking is only available to Eclipse HX-Omega, Eclipse HX-Median and Eclipse HX-Delta matrices.

You can intelligently link Eclipse HX-PiCo matrices using:

- Four-wire connections.
- The PiCo-link to PiCo-link.
- Omega, Median, Delta matrices with IVC-32, and LQ devices.

Note: PiCo-link is only available for Eclipse HX-PiCo to Eclipse HX-PiCo connections. The PiCo-link does **not** support hopping.

The sections below on Fiber trunking and Four-wire trunking provide a basic overview of the intelligent linking process. For more information, see:

- The relevant matrix user guide.
- The Eclipse HX Installation Guide.

If you add or remove trunk lines, you might see the following message:

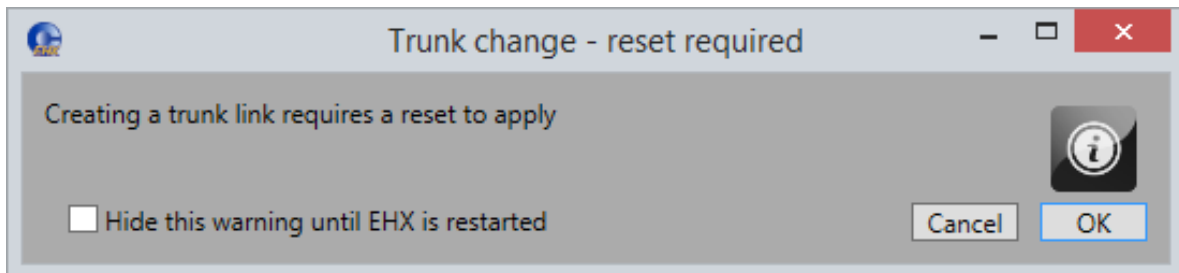

Figure 25-5 Trunk change reset

Click **OK** to continue.

If you add or remove intelligent links, and then apply your configuration to a matrix, you might see the following message when you apply changes to the matrix:

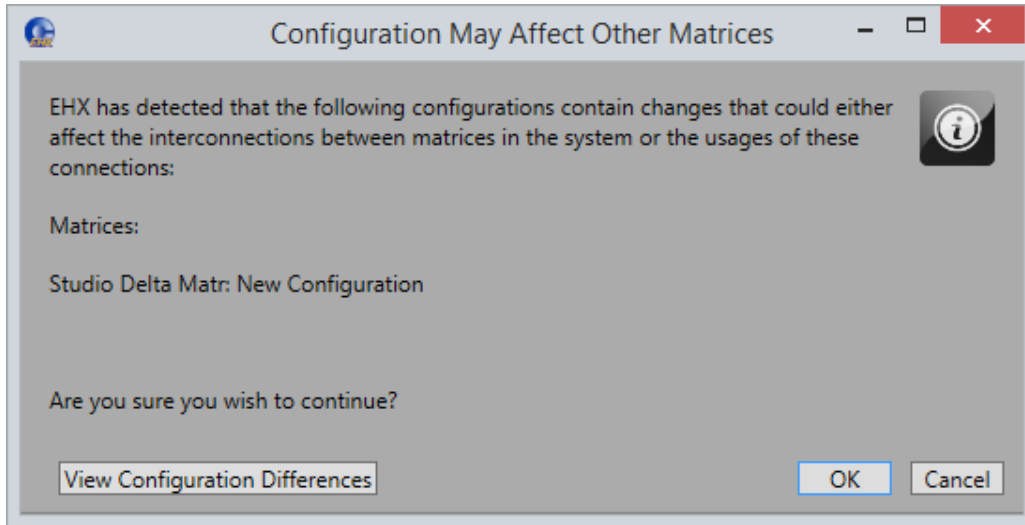

Figure 25-6 Configuration may affect other matrices

Click **View Configuration Differences** to see a list of changes that affect the intercommunication between matrices. You are advised to Apply Changes to all matrices.

Click **OK** to continue, or **Cancel**.

25.2.1 Trunk grouping

If you require more than one trunk, instead of configuring each trunk separately, it might be quicker and more convenient to configure the trunks at the same time. This option is called trunk grouping.

When a trunk is allocated in **Cards and Ports**, if the card has available ports (defined as contiguous ports following the created port) creating a trunk bundle is permitted and the multi channel trunk dialog is displayed.

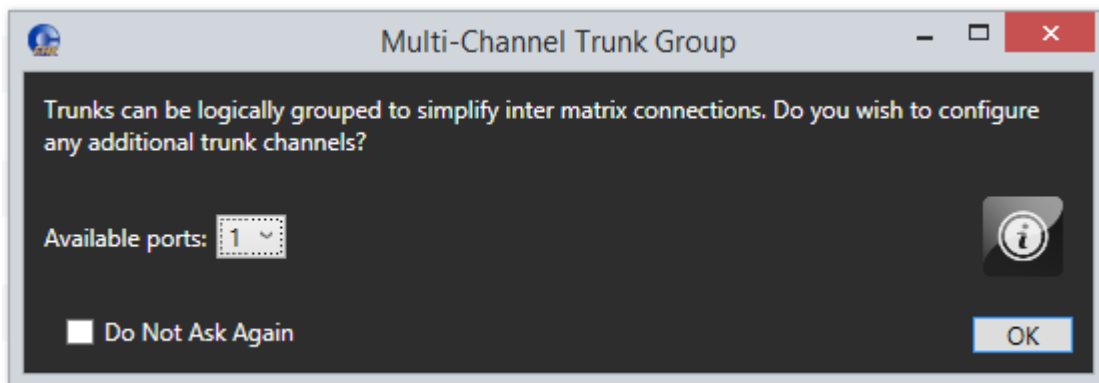

You can select any value from the **Available ports** drop down list, and this number of trunks will be created in total. The default value is one. The Master Port is the port that you initially create.

It can also be done by selecting contiguous trunks and using the right-click context menu.

25.2.2 Intelligent linking preferences

Intelligent Linking ISO and IFB System Access Codes Wireless Beltpacks Panel & Key Operation

Alias Labels

Aliases allow labels to appear differently on a remote system to the local system.

Aliases for this configuration are:

Same as the local label

Local label prefixed with the system number

Freely editable

Comfort Tones

Comfort tone ports are used to indicate a trunking failure to panel users.

	Redirect Port:	Label:
No Trunk	512 <input type="text"/>	NO TK
System Down	513 <input type="text"/>	SYS DN
Trunk Clear	514 <input type="text"/>	TK CL

Intelligent Linking

Pre-mix Intelligent Link Sharing Mode [...](#)

Figure 25-7 Intelligent linking preferences

From **Configuration > Preferences > Intelligent Linking** you can:

- Specify the format of **Alias Labels**. Aliases mean that labels can be displayed differently on a connected, remote system from the way they are displayed on the local system. Choose between the following:
 - Same as the local label
 - Local label prefixed with the system number
 - Freely editable
- Define which ports are used for **Comfort Tones** (warning tones). Comfort tone ports are used to indicate a trunking failure to panel users.
- Enable or disable intelligent link sharing. For more information, see section **25.2 Intelligent linking (trunking)**.

25.2.3 Intelligent linking: port priority

Trunk selection prioritisation is as follows:

Priority	Description
1	Fibre – these trunks are given top rating i.e. they are used whenever possible. This is because the fibre card only exists to trunk matrices together.
2	MADI, Dante – Low latency, linear audio.
3	E1/T1 – G722 or G711 compressed, low latency audio.
4	MVX – Low latency good quality audio, however, typically, link detection is not supported. No link detection when 4-wire cabling used. See appropriate manual for cabling that supports link detection.
5	IVC32 – These are given the lowest rating as they have lower audio quality and increased audio latency.

Table 25-1 Intelligent linking – port priority

25.2.4 Pre-mix intelligent link sharing mode

When enabled, this option allows multiple audio sources to be mixed before being routed out of a matrix over an intelligent link for any route type (for example, talk to remote panel, talk to fixed group with remote members, call to remote IFB).

This pre-mixing of sources onto an intelligent link can reduce the number of intelligent links in use in the system at any one time. For example, if disabled and a panel latches four listen keys to ports on another matrix (matrix B) then four intelligent links will be used while these keys are activated. If the mode is enabled, then only one intelligent link will be used while these keys are activated.

This option is not enabled by default because it means that separate remote source level controls on the panel can affect each other when the sources are sharing the same audio transport. This is because the level control only adjusts the listen level of the intelligent link at the local matrix.

Note: Pre-mixing onto intelligent links is always enabled for the routing to partylines as it has no adverse effects on level control, because when using partylines the levels from partyline members can't be independently adjusted.

Note: Projects imported into EHX that have been created using earlier versions of EHX will have this option automatically enabled.

To enable or disable intelligent link sharing:

- 1) Select **Configuration > Preferences > Intelligent Linking**.
- 2) Select or deselect the **Enable Intelligent Link sharing** check box.

25.2.5 Fiber trunking

To enable fiber trunking, you must install and configure E-FIB fiber cards in the matrices you want to connect.

Fiber trunked matrix matrices are normally connected in a ring configuration. An example connection layout (the IP addresses increment to match the system numbers) is shown below.

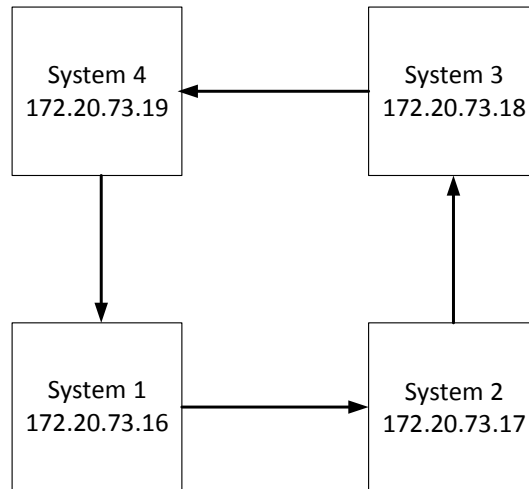

Figure 25-8 Fiber Connections

An example of matrices with trunks is shown below.

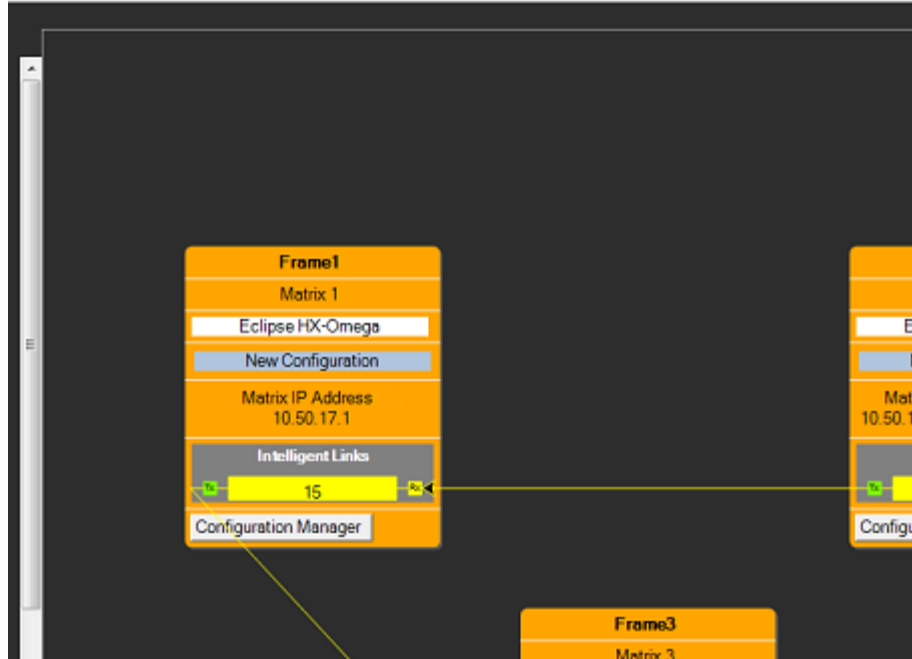

Figure 25-9 Trunk Connections

To configure fiber trunks:

- 1) Open **Hardware > Cards and Ports**, then add an E-FIB card on the first matrix where the trunks are to be configured.
- 2) Open **Hardware > Cards and Ports**, then add an E-FIB card on the second matrix where the trunks are to be configured.
- 3) The systems layout should be automatically updated with the trunk information on both matrices. The trunks have been added to the bottom of each matrix and the port number should be shown. From the System Layout Pane, use your mouse to draw a line joining the trunk ports of the matrices.
- 4) To apply the configuration changes, Select **Apply Map to Matrix** in the System menu.
- 5) Open the File menu and select **Save project** or **Save Project As** to save the updated project.

25.2.6 Four-wire trunks

To configure four-wire trunks:

- 1) Open **Hardware > Cards and Ports**, then select the MVX card on the first matrix where the trunks are to be configured.
- 2) Configure the required ports as **Trunks**.
- 3) Switch to the MVX card on the second matrix, and configure the required ports as **Trunks**.
- 4) On the layout pane, ensure that the required systems layout is open
The systems layout should be automatically updated with the trunk information on both matrices. The trunks have been added to the bottom of each matrix and the port number should be shown. From the System Layout Pane, use your mouse to draw a line joining the trunk ports of the matrices.
- 5) To apply the configuration changes, Select **Apply Map to Matrix** in the System menu.
- 6) Open the File menu and select **Save project** or **Save Project As** to save the updated project.

Note: User-configured trunk labels are ignored in Go Live mode and the default labels should be accepted. When changing the trunking information between matrices all of the matrices in the linked set should be reset. The option to reset matrices is available from the apply dialog.

25.2.7 IP directs and trunks

The Eclipse IVC-32 cards allow directs and trunks over IP network infrastructure. All IP trunks and directs can be compared directly to four-wire trunks and directs. They comprise:

- A single full duplex audio channel
- A known start point and end point

Links have to be made over IP before the trunk/direct can be used.

One side calls the other to set up the link and is known as the VoIP caller. The other side receiving the call checks and decides if it can set up the link – this is the recipient.

If a recipient is not reachable:

- The caller tries three times to establish call
- After it stops trying, a low level thread checks to see if it's reachable again

- Calls will start to try again if the thread sees the recipient

Calls can be refused by the receiver, if:

- The caller is trying to use a non-existent user name
- The caller is using the wrong password
- The caller is not the expected port type (for example, Trunk calling a Panel)
- The call is refused three times, the caller stops calling

If the call is refused three times, to continue making the call you must select **Restart Blocked Connections** at the bottom of the **IVC-32 Diagnostics** screen (see *Restart blocked connections* on page 399).

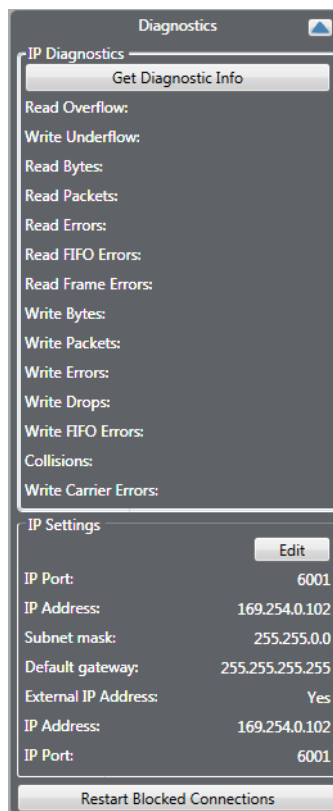

Figure 25-10 IVC-32 Diagnostics screen

You can also access the **Restart Blocked Connections** button by selecting **Detailed** at the top right of the **Monitoring** screen.

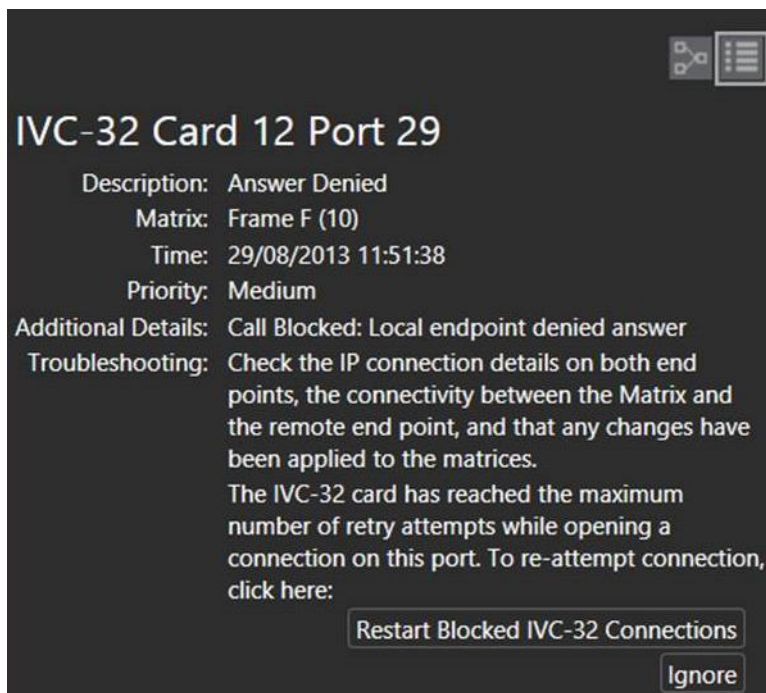

Figure 25-11 Restart Blocked Connections

Configuring an IP direct

- 1) In the **Cards and Ports** screen, for each of the IVC-32 cards, right click on the card and select **Card Properties**.
- 2) From the **IVC-32 Card Properties** screen, enter valid IP addresses and gateways for the card.
- 3) In the **Cards and Ports screen**, select the IP direct port.
- 4) From the properties list, select **IP Port Options**.

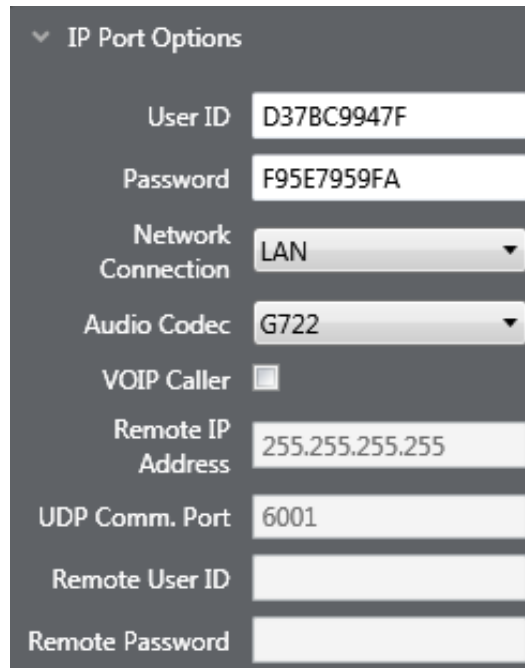

Figure 25-12 IP Port Options

- 5) For the caller IVC-32 card, select the VOIP Caller checkbox. The other card will be the recipient.
- 6) Enter the IP address of the recipient's IVC-32 card into the caller's **Remote IP Address** so it can make setup the call.
- 7) Enter a unique User ID and Password set which matches the IP Direct Port recipient to identify the port it is linking to.
- 8) Navigate to the recipient IVC-32 IP Direct Port, and ensure that the User ID and Password match what was set in the caller settings.

Note: The following settings can be ignored:

- Local User ID/Password can be ignored for caller
- Remote IP and User ID/Password can be ignored for recipient

Once set up, the IP Direct ports will behave in the same manner as all other Direct ports

As each caller can point to a unique IP address, IP directs on one IVC-32 can link to 32 different destination devices. IP directs cannot link back to a direct on the same card, but can link to other cards on the same Eclipse matrix.

Configuring an IP trunk

- 1) In the **Cards and Ports** screen, for each of the IVC-32 cards, right click on the card and select **Card Properties**.

- 2) From the **IVC-32 Card Properties** screen, enter valid IP addresses and gateways for the card.
- 3) In the **Cards and Ports screen**, select the trunk port.
- 4) From the properties list, select **IP Port Options**, and enter valid settings for the **Network Connection**, **Audio Codec** and **VOIP Caller**. The VoIP caller field will be automatically populated when the trunk lines are drawn on the layout screen.

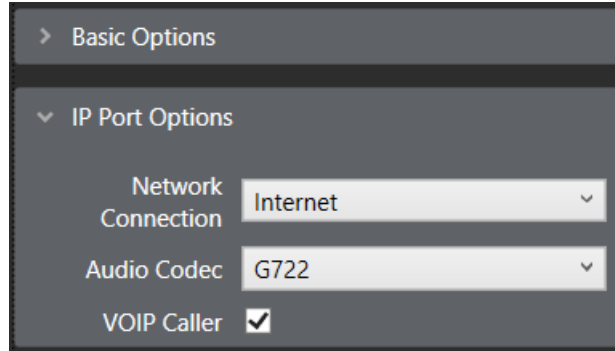

Figure 25-13 IP Port Options

- 5) Repeat for any matrices in the linked set you wish to link over IP (1 port per trunk link, point to point).
- 6) In the Layout screen, drag the trunk links as required. The direction of the drag creates the link as Caller to Recipient.

Note: Right clicking on the link and the ports allow you to change caller, network connection type and flip ports.

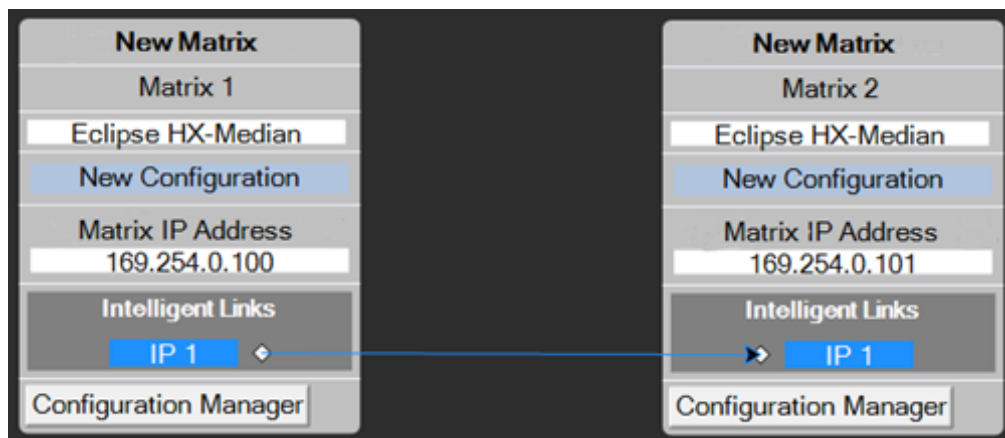

Figure 25-14 IP Links

25.2.8 LQ trunks – Eclipse Omega/Median/Delta to PiCo

You can configure a port on an IVC-32 card as an LQ trunk, and use this trunk to link to any 4-Wire trunk port, including a PiCo matrix, via an LQ Series device, as shown below.

IP trunking: Eclipse HX to Pico HX (EHX 8.7 and above)

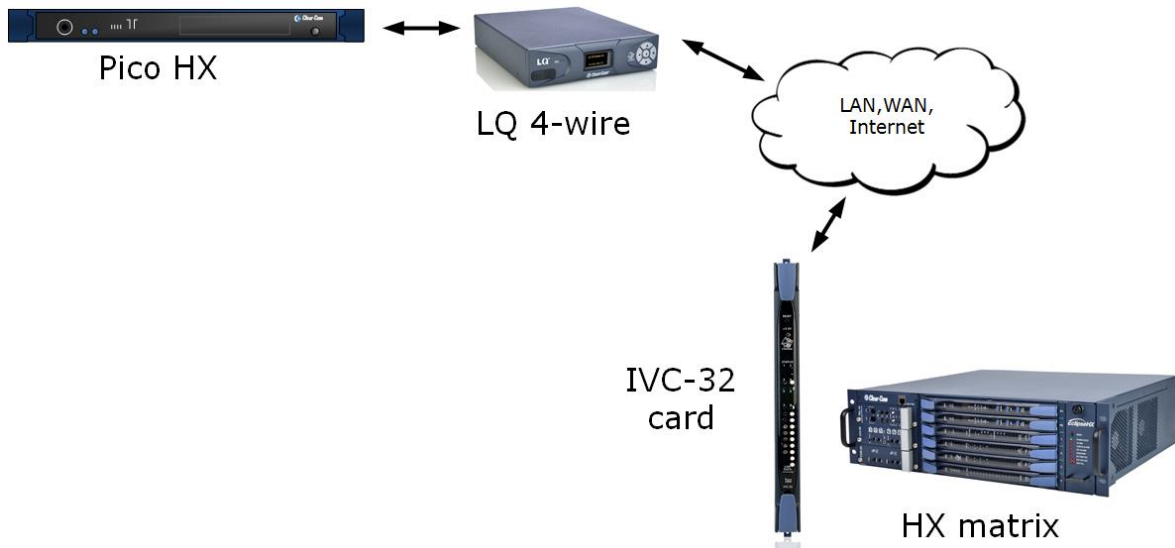
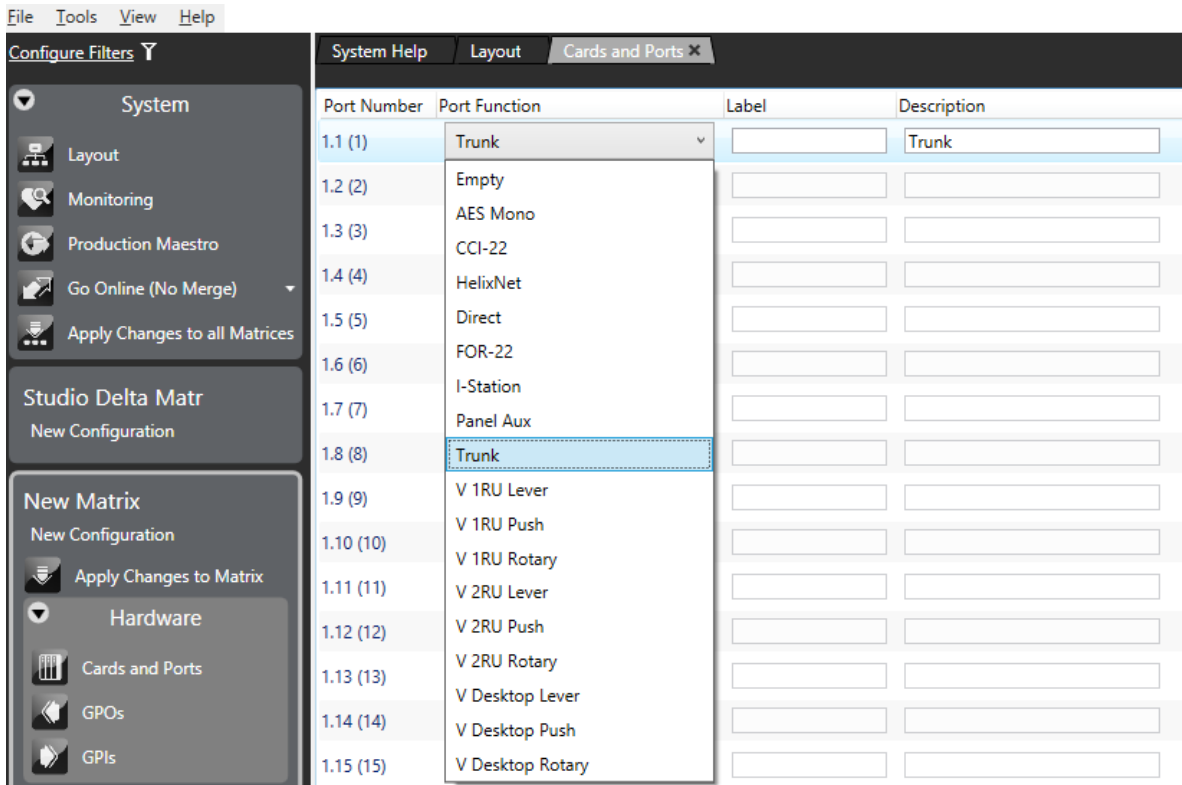

Figure 25-15 Eclipse HX to PiCo HX

To access and configure the IVC-32 port:

- 1) On the PiCo matrix, go to **Hardware > Cards and Ports**.
- 2) From the port drop-down list, select **Trunk**.



3) On the Omega, Median or Delta matrix, Go to **Hardware > Cards and Ports** and select the IVC-32 card.

4) From the drop-down list, select **LQ Trunk**.

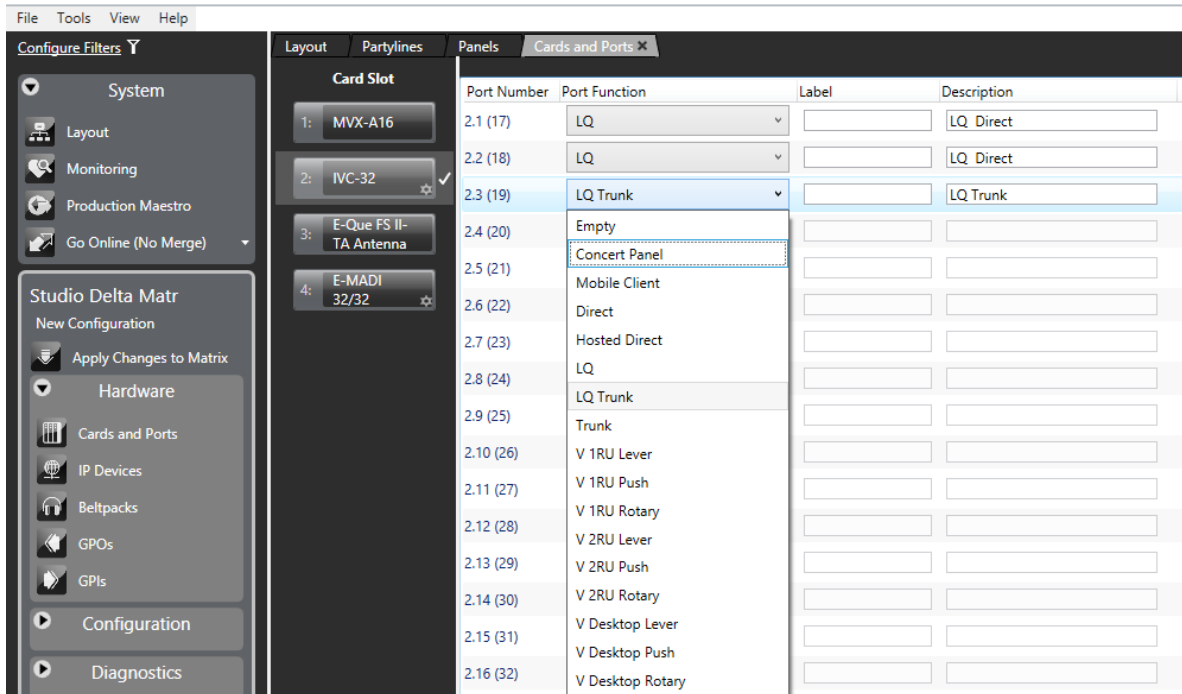

- 5) Highlight the port, and expand the **Basic Options** and **IP Port Options** properties.

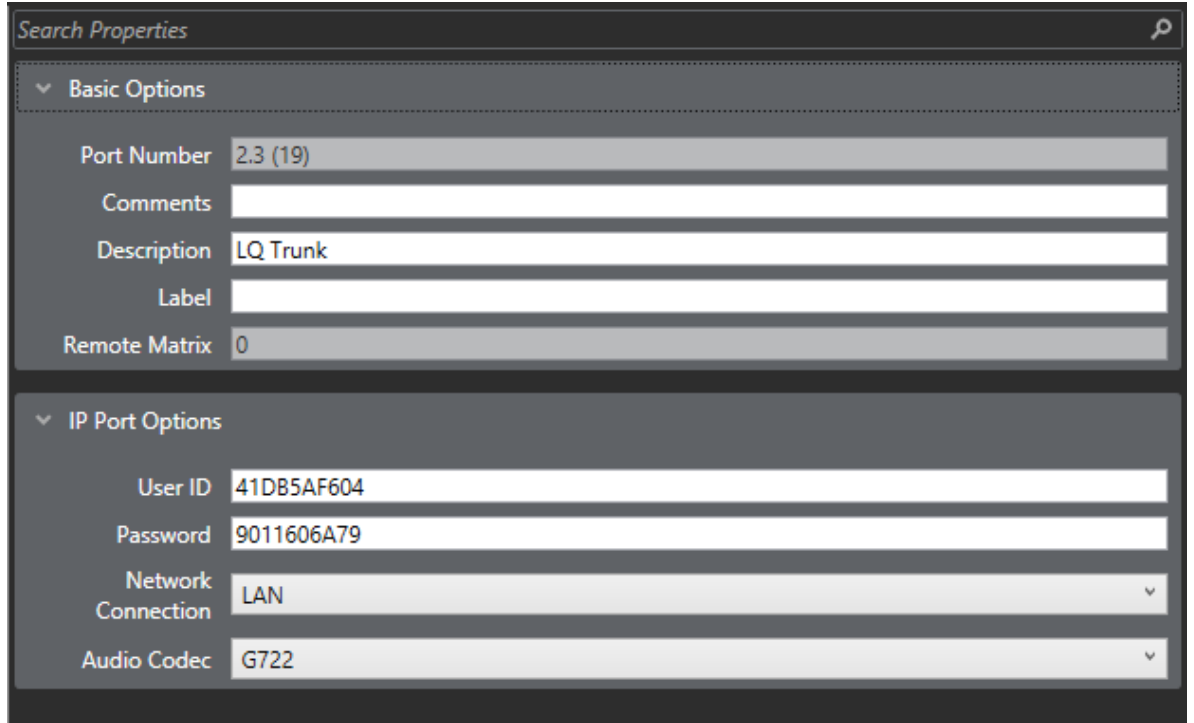

The screenshot displays a configuration window titled "Search Properties". It is divided into two main sections: "Basic Options" and "IP Port Options".

Basic Options:

- Port Number: 2.3 (19)
- Comments: (empty field)
- Description: LQ Trunk
- Label: (empty field)
- Remote Matrix: 0

IP Port Options:

- User ID: 41DB5AF604
- Password: 9011606A79
- Network Connection: LAN (dropdown menu)
- Audio Codec: G722 (dropdown menu)

- 6) In **Basic Options**, you can enter an optional Comment and Description, and enter a Label to identify the LQ Trunk.
- 7) In IP Port Options, enter or select:
- The User ID – a default ID is automatically generated that you can edit as required.
 - Password - a default password is automatically generated that you can edit as required.
 - Network Connection (LAN, WAN or Internet).
 - Audio Codec (G722).
- 8) From the layout screen, link the trunk ports on the matrices together by dragging from one port to another.

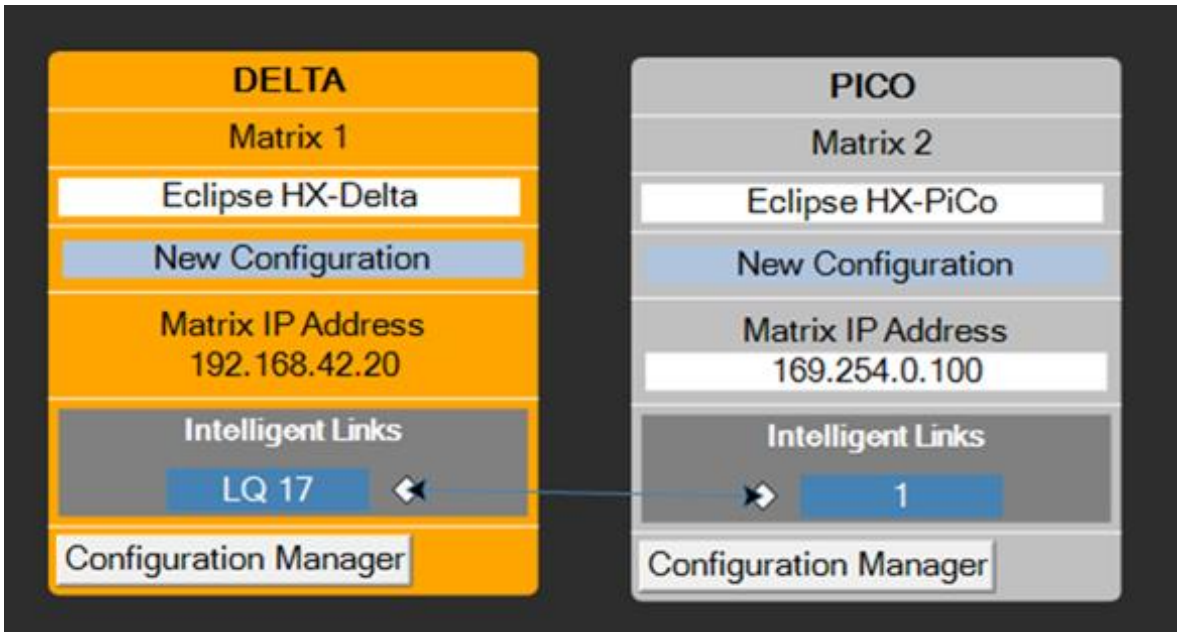

- Configure the LQ Trunk Ports on your LQ device from the External screen in the LQ Core Configuration Manager.

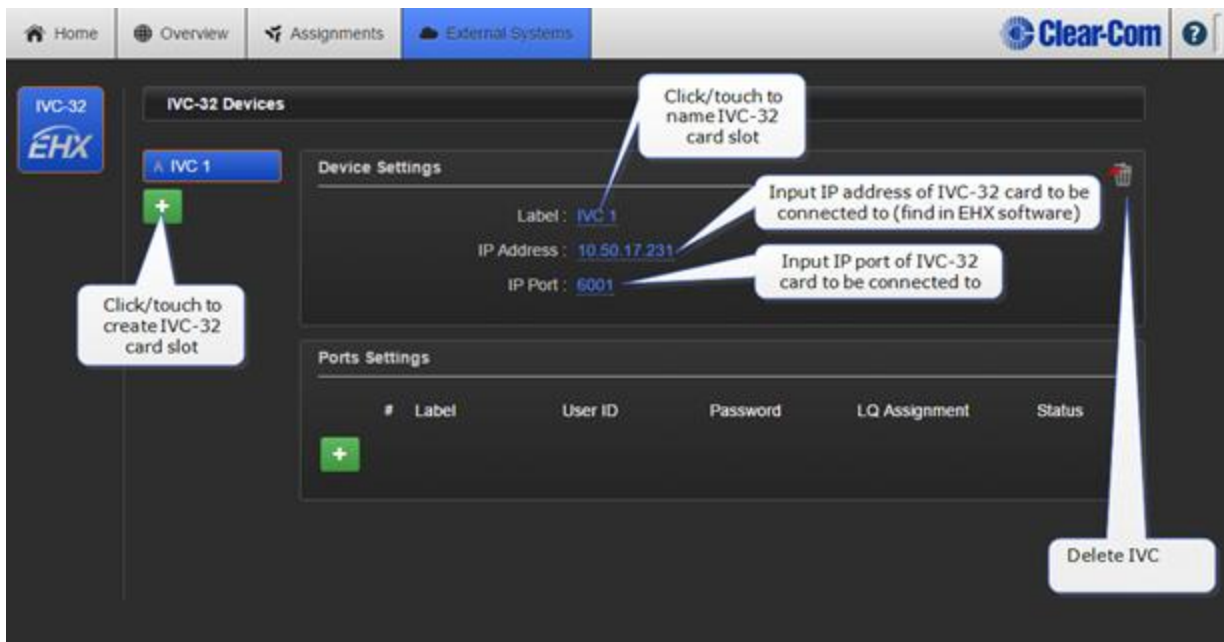

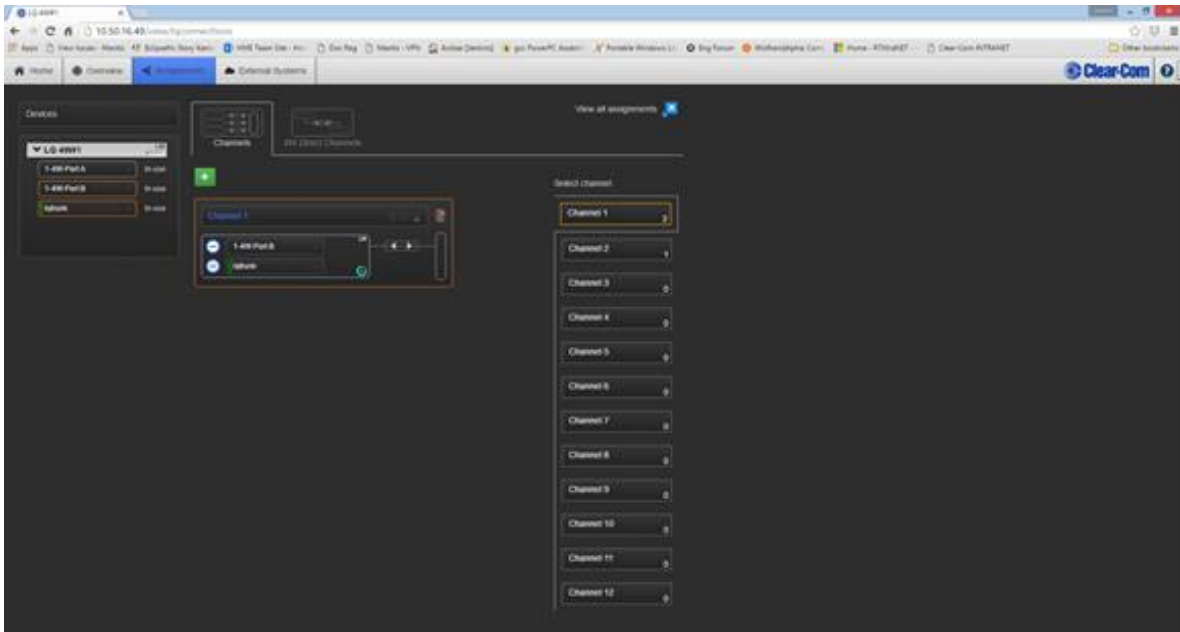
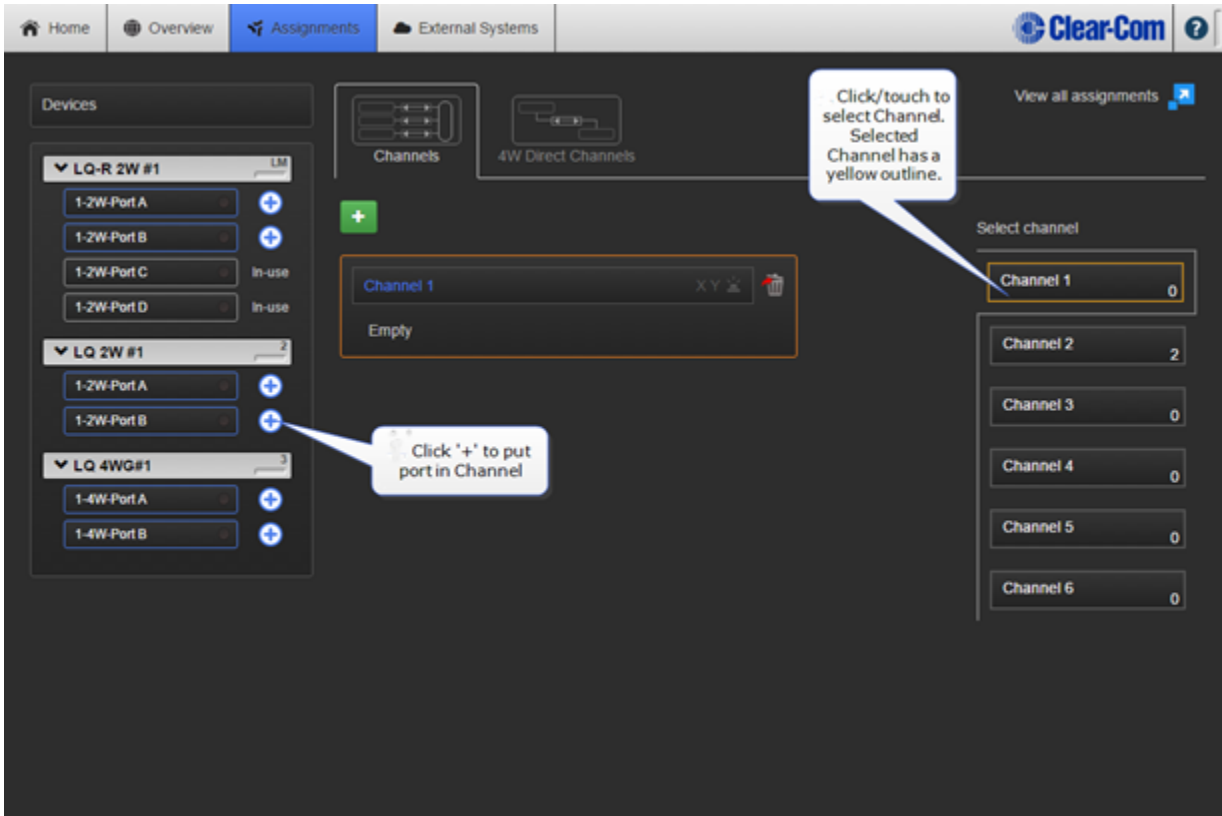

25.2.9 Intelligent linking with PiCo-Link

Note: You can create a high capacity CAT-5 connection between two Eclipse HX-PiCo matrix frames using the **PiCo-Link** connector on each device. Hopping is not supported.

Note: The last four ports on an Eclipse HX-PiCo matrix frame are four-wire ports, and not available for panel connections, and are recommended as 4-wire trunks to other matrices.

Note: Clear-Com recommends that you do not add other ports apart from the 4-W port to the 4-W trunk port on the matrix and the IVC-32 port that connects to the LQ trunk port on the other matrix. Otherwise, the intelligent link may contain undesired audio.

The 36 ports of the first matrix frame are intelligently linked to the 36 ports of the second, creating a **72-port non-blocking system**.

You can create one non-blocking 72 port Eclipse HX system by connecting two Eclipse HX-PiCo matrix frames (matrices) together, using the PiCo-Link RJ-45 connectors on the matrices.

To make this connection, use a specially constructed screened CAT-5 cable of maximum length 1 meter (3.28 feet). The cable is wired as shown in Table 25-2 below.

Cable end 1	Wire color	Cable end 2
Pin 1	White / orange	Pin 3
Pin 2	Orange	Pin 6
Pin 3	White / green	Pin 1
Pin 4	Blue	Pin 4
Pin 5	White / blue	Pin 5
Pin 6	Green	Pin 2
Pin 7	White / brown	Pin 7

Table 25-2: CAT-5 crossover cable pinout

To transfer data between two linked Eclipse HX-PiCo matrices using the PiCo-Link also requires that the Ethernet ports are connected with either a cross-over shielded CAT-5 cable or a switch using conventional shielded CAT-5 cable.

Setting up a Pico link

To set up a Pico link:

- 1) In the Layout screen, for each Pico matrix, select **Hardware > Cards and Ports > PiCo-Link**.

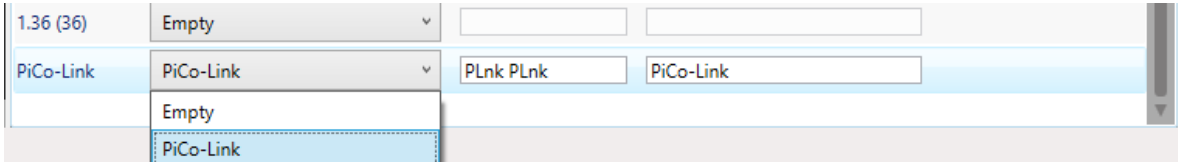

Figure 25-16 PiCo Link

- 2) In the drop-down list, select **PiCo-Link**.
- 3) In the Layout screen, using the mouse drag a link from one Pico matrix to the one you need to link to.

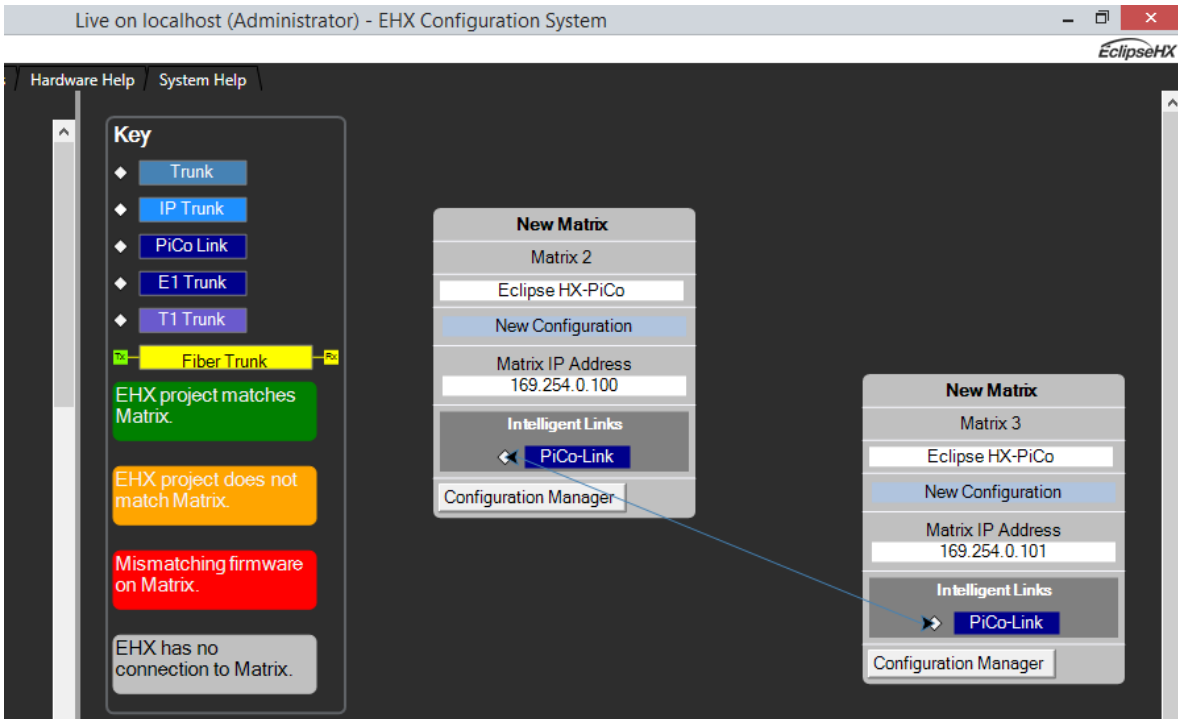

Figure 25-17 Pico-Link drag and drop

If you want to disable the link:

- On the Layout screen, click on the link connecting the two Pico matrices and press **Delete**.

25.3 Programming remote labels

- 1) Select **Configuration > Panels**.

- 2) From the Panel Programming area of the screen select the required panel to be programmed by either selecting the panel from the drop down list or cycling through the panels by selecting the left or right arrows.
- 3) To assign keys click on the required item in the list of available labels, drag the items to the required key and drop them over the display corresponding to the key and then click on the mouse to confirm the assignment.
- 4) When the labels have been programmed onto the required panel or panels, apply the changes by selecting the **Apply Changes To System** link in the System menu. The newly programmed labels should appear in the required positions.
- 5) To program labels onto the next matrix, switch between the configurations by selecting the required matrix from the layout pane.

25.4 Remote fixed groups

Remote Members from one system can be added to a Fixed Group of a local system.

To configure a remote member to a local Fixed group:

- 1) Select **Fixed Groups** from the **Configuration** menu.
- 2) Create a Fixed Group by clicking on the **New** button.
- 3) Enter the Talk and Listen labels for the new Fixed Group and a description if required.
- 4) Set up the properties of the new Fixed Group using the properties dialog in the **Properties** pane.

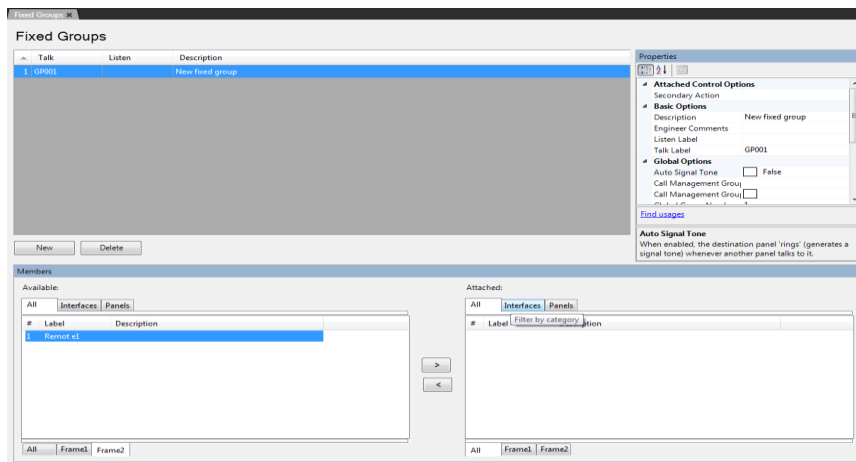

Figure 25-18 Remote Fixed Groups

- 5) Select the members of the group from the **Available** pane and click on the **>** button to transfer them to the **Attached** pane. They are now members of the group. To remove members from the group select them in the **Attached** pane and click on the **<** to transfer them back to the **Available** pane.
- 6) Click on the **Apply Map to Matrix** button to apply the new map to the matrix immediately or close the **Fixed Groups** dialog if other changes are to be made.

Note: The available members area is filtered according to the active matrix filters, but the attached area always shows all attached members, even if their matrices are filtered out.

25.5 Remote partylines

To add remote partyline members from one system to the partyline of a local system:

- 1) Select **Partylines** from the **Configuration** menu.
- 2) Create a partyline by clicking on the **New** button.
- 3) Enter the Talk and Listen labels for the new partyline and a description if required.
- 4) Set up the properties of the new partyline using the properties dialog in the **Properties** pane.

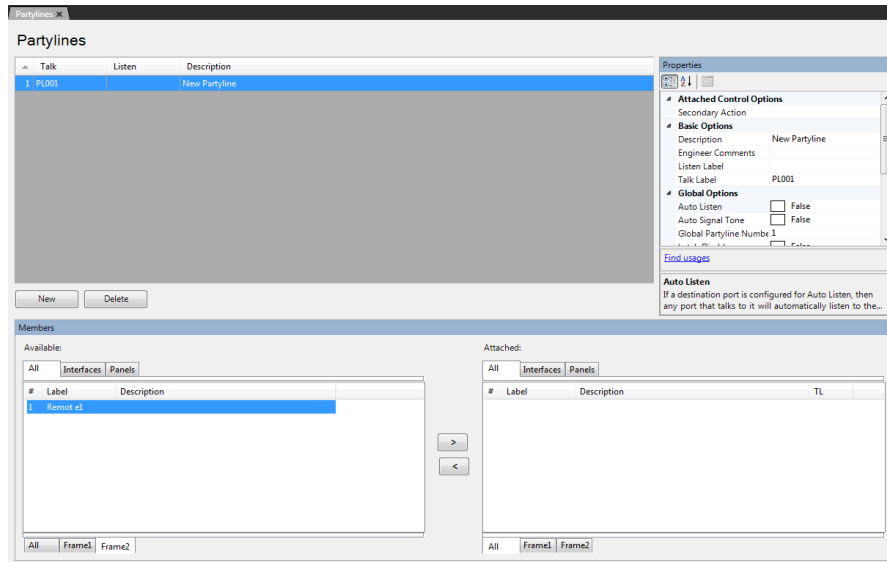

Figure 25-19 Remote Partyline

- 5) Select the members of the partyline from the **Available** pane and click on the **>** button to transfer them to the **Attached** pane. They are now members of the partyline. To remove members from the partyline select them in the **Attached** pane and click on the **<** to transfer them back to the **Available** pane.

- 6) Click Apply Changes to apply the new map to the matrix immediately or close the Partyline dialog if other changes are to be made.

Note: The available members area is filtered according to the active matrix filters, but the attached area always shows all attached members, even if their matrices are filtered out.

25.6 Remote 2-way radio

If a 2-way radio system is connected via a FOR-22, the 2-Way Radio can operate over an intelligently linked system.

To configure a remote 2-way radio:

- 1) Create a control. Attach the relay for the FOR-22, and set the control as a secondary action on the FOR-22.

- 2) Apply and reset the first matrix.

- 3) Switch matrices, and open **Panels > Remote Interfaces**. Locate the remote 2-way radio

- 4) Program the 2-way radio onto the required panel and click **Apply Label Changes**.

When a 2-way radio contributes audio to a partyline, the VOX on the port will detect the audio and fire any other 2-way radio that is in the partyline but will NOT fire itself.

Note: The Vox timeout and activation level for the 2-way radio port should be set to the users preference.

The relay for a 2-way radio in a partyline is also activated by the key from a panel when the Audio Presence tally is off in the properties for that panel.

If more than one 2-way radio contributes audio to the partyline then all 2-way radio relays including the contributors will turn on.

Note: A call signal to a partyline will also trigger the Relay.

Note: There may be some delay activating the 2-way radio relay when a partyline has multiple 2-way radios in because audio coming into the system on one radio will trigger the vox that will in turn activate the PTTs on the other radios in the partyline.

For information about radio interfacing with Clear-Com systems, see the Clear-Com Gateway product documentation.

25.7 Remote telephone

Remote Telephone functionality enables you to configure a TEL-14 telephone module on one system to be available for use on another system. To make a remote telephone call, DTMF tone generation is required.

An Eclipse HX user panel (V-Series or i-Series) can make remote calls both manually (using the dial pad) and through speed dials.

Note: For more information about setting up and using the TEL-14 module, see the **TEL-14 User Guide**. For more information about user panels, see the **V-Series User Guide** and the **i-Series manual**.

25.7.1 Remote manual dial

User panels can manually dial a remote telephone, using the dial pad. The panel registers as a dialler to the telephone as soon as the panel starts dialling the telephone through the dial pad.

When the panel comes out of dial mode (ends the call), registration to the telephone port is released.

Note: Only one port at a time (local or remote) can dial the telephone.

25.7.2 Remote speed dial

To set up a speed dial to a remote telephone between two linked matrices:

- 1) Open the Panels screen and locate the telephony interface in the label palette
- 2) Program the telephony interface onto any required panel(s)
- 3) In Controls, select the control for the speed dial and program next to the telephony interface
- 4) Activate a talk for the telephone
- 5) Activate the speed dial (make the call).

Alternatively:

- 1) Set-up telephone and speed dial as above.
 - 2) Switch matrices
 - 3) Program the telephony interface onto any required panels
 - 4) Double click the talk label to the telephony interface
 - 5) Select controls and click on the speed dial control
 - 6) Add to the stacked key area.
 - 7) Apply to the matrix
- Activating the talk to the telephone operate the speed dial and the call is made

25.7.3 Off hook and off hook tally

If a talk route is made to that telephone port from either a local or a remote system, the telephone is automatically placed off-hook.

Note: The TEL-14 interface port must be set to Auto-Answer.

The off hook tally state of a telephone port is broadcast to all the systems in a linked set.

To check if the telephone port has been configured as an off hook tally, see the entity table.

25.7.4 Auto listen

In Eclipse HX, you can set Auto Listen for ports on both the local matrix and remote matrices.

If a remote port on a matrix has Auto Listen set, any talk path made to it from anywhere in the system has a return listen route made.

25.8 Remote controls

Controls from one system are made available for use in another system.

To configure remote controls

- 1) Create the required controls on a local system
- 2) Select **Save Linked Configurations**

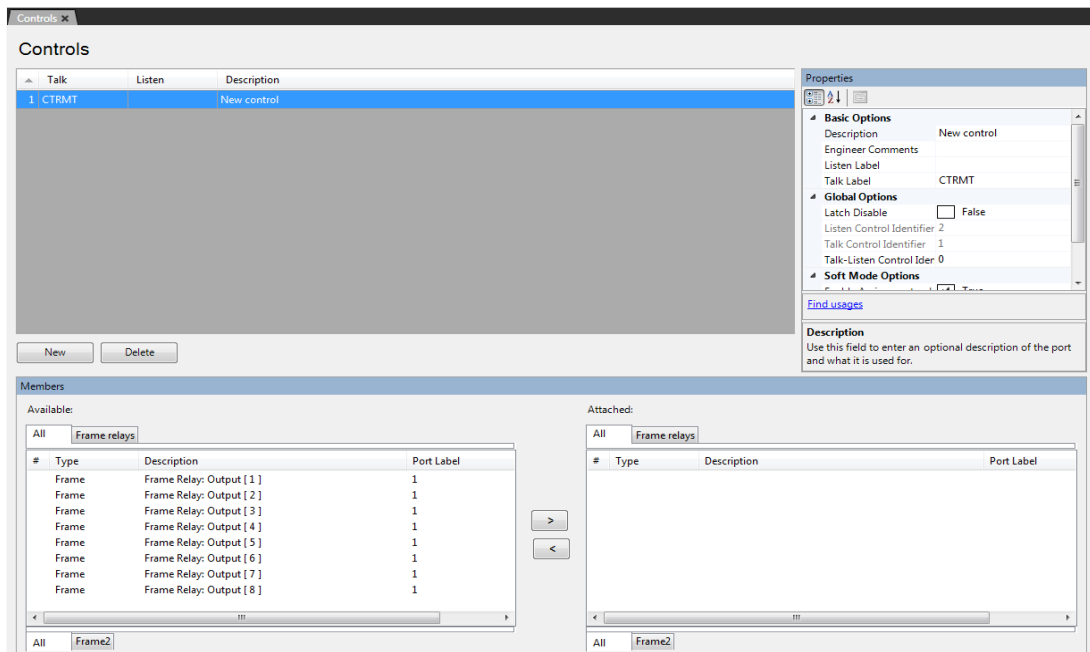

Figure 25-20 Remote Controls

- 3) Switch matrices
- 4) Open **Panels**. Select the Controls tab in the labels section of the window

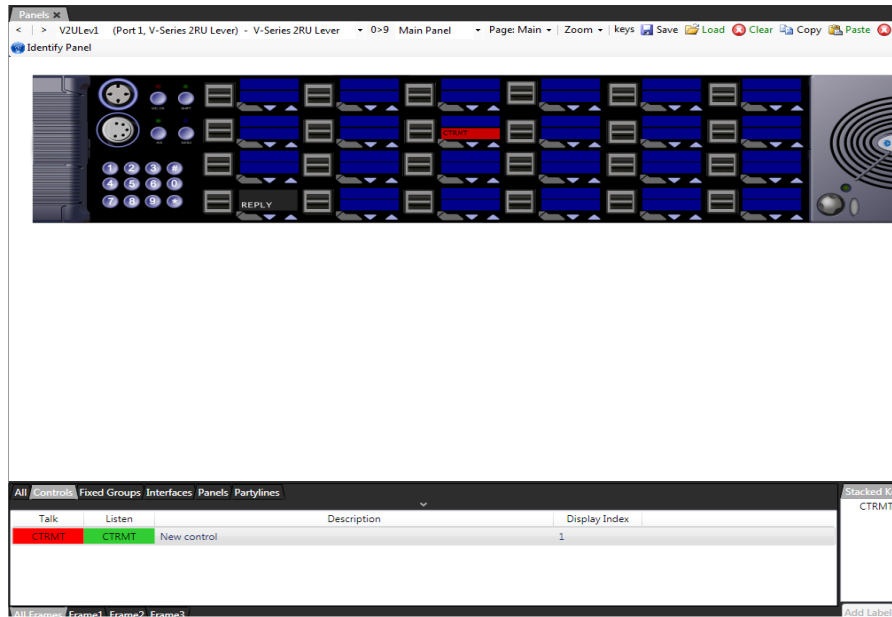

Figure 25-21 Controls on a Panel

5. A complete list of controls is displayed. Locate the required control.
6. Program onto any required panel, using drag and drop
7. Apply to the matrix.

25.9 Remote secondary actions

Other functionality implemented is the remote secondary action where a control can be attached to a label as a secondary action.

25.10 Remote IFBs

Panels can have a key to an IFB configured on a remote matrix.

26 Client server

26.1 Client/server operation

Client/Server operation enables multiple clients to share and apply configurations to one or more matrices using a central server which runs EHX.

The application ensures that while a user is editing a configuration, other users are prohibited from also making edits to the same configuration.

If client/server operation is being used then all the EHX PCs on the network should be configured to run in this mode.

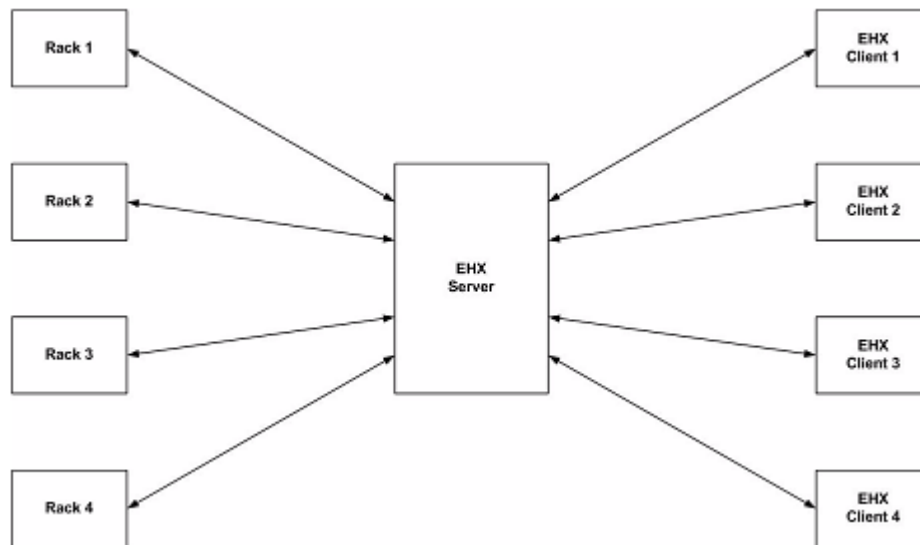

Figure 26-1 EHX Client Server Wiring

26.1.1 Client

EHX must be installed on each client that is used to make edits to configurations or update racks. The user chooses the server to use when logging in as EHX starts up. The server distinguishes between clients by Username.

26.1.2 Server

The server controls all communications between the clients and the matrices. The server stores all of the projects and ensures that when one configuration is being edited by a client, no other client can edit that configuration at the same time.

The server must also be running IIS (Internet Information Services - a web server provided by Microsoft).

The EHX server provides the **back-end** services, such as map-building, configuration sharing, and access to the matrices. Clients access the server with an Ethernet connection.

26.1.3 Initial setup

The following steps need to be completed in the specified order:

- 1) Install and configure IIS on the server system.
- 2) Install EHX Server.
- 3) Install EHX Client on each client PC.
- 4) Configure each client PC to access the server.
- 5) Login to the server from a client machine.

Note: The default installation path is assumed to be **C:\Program Files\ClearCom\Eclipse HX Configuration Server**

Installing and Configuring IIS on the Server

Stage 1 - Verify IIS is installed

To verify that IIS has been installed:

- 1) Go to the Windows **Control Panel**.
- 2) Double click **Administrative Tools**.
- 3) Verify **Internet Information Services** exists and is at version 5.0 or above.

Note: For more information about the options that are not selected by default, but which must be enabled for EHX to run successfully, see **IIS options that must be enabled** below.

If IIS does **not** exist on the server, complete **Stage 1b**. Otherwise, proceed to **Stage 2**.

Stage 1b - Install IIS

Note: The exact procedure may vary depending on the version of Microsoft Windows.

To install IIS:

- 1) Open the Windows **Control Panel**.
- 2) Double click **Programs and Features**.
- 3) Select **Turn Windows features on and off**.

- 4) Select **Internet Information Services** and complete the install using the wizard.

Note: For more information about the options that are not selected by default, but which must be enabled for EHX to run successfully, see **IIS options that must be enabled** below.

IIS options that must be enabled

When installing Internet Information Services, there are certain options which are not selected by default, and that **must** be enabled to allow EHX to run successfully. (You can select any other options in addition to these, without risk to the installation).

Windows 7 and 8.1

In Windows 7 and 8.1:

- 1) Go to Control Panel.
- 2) Select **Programs > Turn Windows features on or off**.
- 3) Under Internet Information Services, make sure the following options are enabled:
 - Web Management Tools
 - IIS 6 Management Compatibility
 - IIS 6 Management Console
 - IIS6 Scripting Tools
 - IIS6 WMI Compatibility
 - IIS Metabase and IIS6 configuration compatibility
 - IIS Management Console
 - World Wide Web Services
 - Application Development Features
 - Net Extensibility
 - ASP.NET
 - ISAPI Extensions
 - ISAPI Filters
 - Common HTTP Features
 - Default Document
 - Directory Browsing
 - HTTP Errors

- Static Content
 - Performance Features
 - Static Content Compression
 - Security
 - Basic Authentication
 - Windows Authentication
- 4) Under Microsoft .Net Framework 3.0, make sure the following options are enabled:
- Windows Communication Foundation HTTP Activation
 - Windows Communication Foundation Non-HTTP Activation

Windows Server 2008 R2

In Windows Server 2008:

- 1) Go to Server Manager.
- 2) Click Add Roles.
- 3) Select Web server (IIS) and click Next.
- 4) Under Role Services, ensure the following options are enabled:
 - Web Management Tools
 - IIS 6 Management Compatibility
 - IIS 6 Management Console
 - IIS6 Scripting Tools
 - IIS6 WMI Compatibility
 - IIS Metabase and IIS6 configuration compatibility
 - IIS Management Console
 - World Wide Web Services
 - Application Development Features
 - Net Extensibility
 - ASP.NET
 - ISAPI Extensions
 - ISAPI Filters

- Common HTTP Features
 - Default Document
 - Directory Browsing
 - HTTP Errors
 - Static Content
 - Performance Features
 - Static Content Compression
 - Security
 - Basic Authentication
 - Windows Authentication
- 5) From Server Manager, click Add Features.
- 6) Ensure that the following features are enabled:
- Net Framework 3.5.1 Features
 - Net Framework 3.5.1
 - WCF Activation
 - HTTP Activation
 - Non-HTTP Activation

Windows 8/Windows 10

In Windows 8/10

- 1) Go to Control Panel
- 2) Select **Programs > Turn Windows features on or off**
- 3) Under Internet Information Services, make sure the following options are enabled:
 - Web Management Tools
 - IIS 6 Management Compatibility
 - IIS 6 Management Console
 - IIS 6 Scripting Tools
 - IIS 6 WMI Compatibility
 - IIS Metabase and IIS 6 configuration compatibility
 - IIS Management Console

- IIS Management Scripts and Tools
 - World Wide Web Services
 - Application Development Features
 - NET Extensibility 3.5
 - NET Extensibility 4.5
 - ASP.NET 3.5
 - ASP.NET 4.5
 - ISAPI Extensions
 - ISAPI Filters
 - Common HTTP Features
 - Default Document
 - Directory Browsing
 - HTTP Errors
 - Static Content
 - Performance Features
 - Static Content Compression
 - Security
 - Basic Authentication
 - Windows Authentication
- 4) Under .NET Framework 3.5 (includes .Net 2.0 and 3.0)
- Windows Communication Foundation HTTP Activation
 - Windows Communication Foundation Non-HTTP Activation
- 5) Under .NET Framework 4.5 Advanced Services
- ASP.NET 4.5
 - WCF Services
 - HTTP Activation
 - Message Queuing (MSMQ) Activation
 - Named Pipe Activation
 - TCP Activation
 - TCP Port Sharing

Stage 2 - Install EHX Server

- 1) Install EHX Server (Run the EHX server installation *.exe file).

For Windows XP, Windows Vista and Windows 7 systems, .Net Framework should automatically be configured in IIS.

Client configuration

An EHX client installation is required on each client system.

Login to the server from a client machine

- 1) At the EHX login dialog box click the Options button to display the **Log on to** field.
- 2) Type the following string, replacing <Machine Name> with the name of the EHX server: `http://<Machine Name>/EclipseServer/`.

The client must be able to connect to the server to login. If it cannot connect an appropriate error is displayed. This problem may even be encountered in the case where the client is on the same machine as the server when the machine is not connected to the network.

If the access to the server is required with the machine in this state, setting the EHX server as `http://127.0.0.1/EclipseServer/` allows this (this is using the network loopback address).



Figure 26-2 EHX Client Log in

Note: To determine the EHX Server Machine Name log in to the EHX Server. Click Start and then Run. Type `cmd` into the box and click ok. At the command prompt type `ipconfig /all`. Use the listed Host Name as the EHX server name.

Using Client/server

Username

Each user is distinguished by Username and users on different clients should always use different Usernames when logging in to the EHX Server.

Usernames on the EHX server are set up by logging in to the EHX Server and using the User Management facility as described in chapter 3 to set up and manage users.

If a user on a client attempts to log in to the EHX Server with a Username that is already in use a warning is shown. If the new user continues, the existing user session is terminated, and the user who has now been logged out is informed.

Host name

When logging in to an EHX server running in client/server mode use the **Options** button to display the server that the user is logging on to and enter the server name explicitly instead of using the default local host name.

27 Using the diagnostic tools

The **Diagnostics** menu accesses tools that display information about the state of the system's hardware and software operation that is useful for diagnosing and preventing problems.

Note: The **Save Diagnostics Information** utility (**Help > Save Diagnostics Information**) enables you to take a snapshot of the current state of your project, the EHX PC and the matrices, and store this information as a zip file on your computer. This information can then be sent to Clear-Com support to assist with the diagnosis of issues.

For more information, see section **27.7 Save diagnostics information utility**.

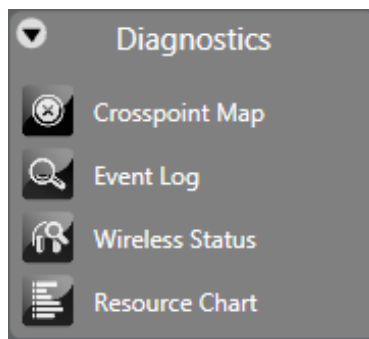

Figure 27-1 Diagnostics Menu

Note: The Beltpack Status and Antenna Status options are only available if there is an E-Que FS II-TA Antenna or an E-Que FS II-TA Splitter in the matrix.

27.1 Crosspoint map

Use the Crosspoint map to give a visual display of all crosspoints or source-to-destination assignments in the matrix system. The crosspoint map is a graphical representation of all inputs and outputs in the system.

You can use this map to identify talk and listen assignments, forced listens and blocked listens. You can also use it to make or cancel crosspoints and to override input and output levels set up in the map.

The grey triangles denote active crosspoints, pink half circles denote auto listen crosspoints, red crosses denote blocked listen crosspoints and violet half circles denote forced listen crosspoints.

The crosspoint map displays both the labels and the port numbers the labels are associated with for ease of identification.

- 1) Select **Diagnostics > Crosspoint Map**

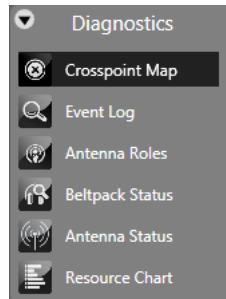

Figure 27-2 Crosspoint Map

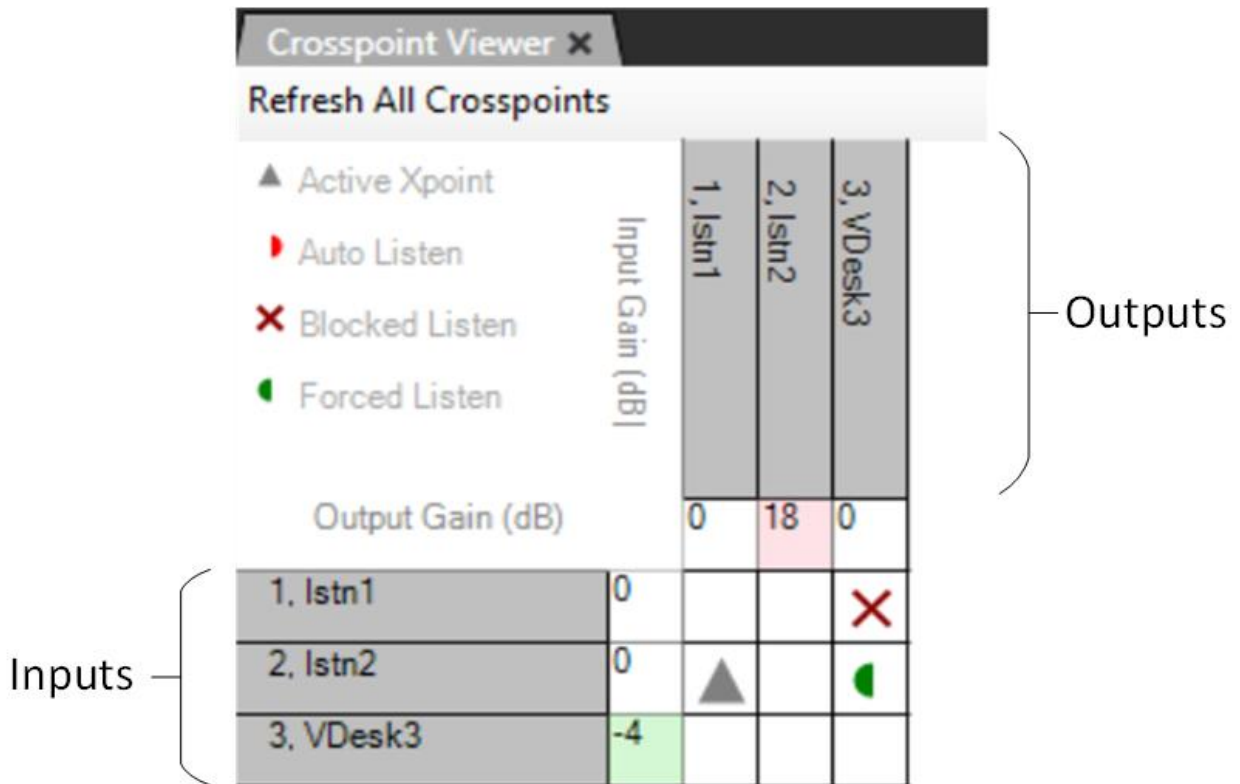

Figure 27-3 Crosspoint Monitor Display

The inputs are listed down the left hand side of the table with the input gain settings, while the outputs are listed along the top of the table with the output gain settings.

- 2) Right click a cell representing a crosspoint to display a list of options. To toggle a crosspoint from the **On** state to the **Off** state click on the **State** option and then click on **Toggle** in the next menu. Select the **Kill** option from the **State** menu to clear a crosspoint completely.

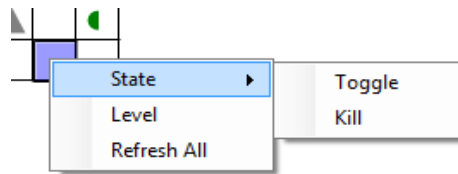

Figure 27-4 Crosspoint State Options

- 3) To set the crosspoint level, select the level option on the menu to display the crosspoint level slider and set the required level.

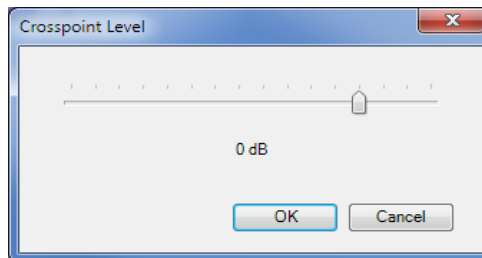

Figure 27-5 Crosspoint Level Slider

Note: Leave signalization still active on the panel.

- 4) Select the **Refresh All** option to update the display with the crosspoint settings current on the matrix.
- 5) Use Ctrl+ (zoom in) and Ctrl- (zoom out) to zoom in or out, producing clearer views of the map, or if a wheel mouse is available use Ctrl and the wheel to zoom.
- 6) Click on the **Refresh All Crosspoints** button at the top of the crosspoint map to request the crosspoint information from the matrix and use it to update the crosspoint map.

When an input or output level is changed it affects all the crosspoints that are connected to the port. If an input level for a port is reduced the input level to all the crosspoints for that port is reduced (all the crosspoints in the column below the level). If an output level is changed all the crosspoints in that row are affected. Note that these levels only change the input and output levels for the ports. They do not change the crosspoint level settings.

- 7) Right click on an input or output setting (the cell next to the port information) to display a list of gain values.

Clicking a value in the list sets the input or output gain to the required level in the matrix. This value remains in force until it is either changed

again using the Crosspoint Monitor or a new map is applied and the matrix is reset to the default values in the map.

If the matrix is only reset without a new map applied the modified values set up using the Crosspoint Monitor remain in force.

The settable values are: +18, +15, 12, +9, +6, + 5, +4, +3, +2, +1, 0, -1, -2, -3, -4, -5, -6, -7, -8, -9, -10, -12, -14, -16, -20, -35, -45 and -72dB.

The current value can also be reset to the default value set up in EHX from this list.

The input/output cells are color coded to show whether the level is higher (red) or lower (green) than 0dB.

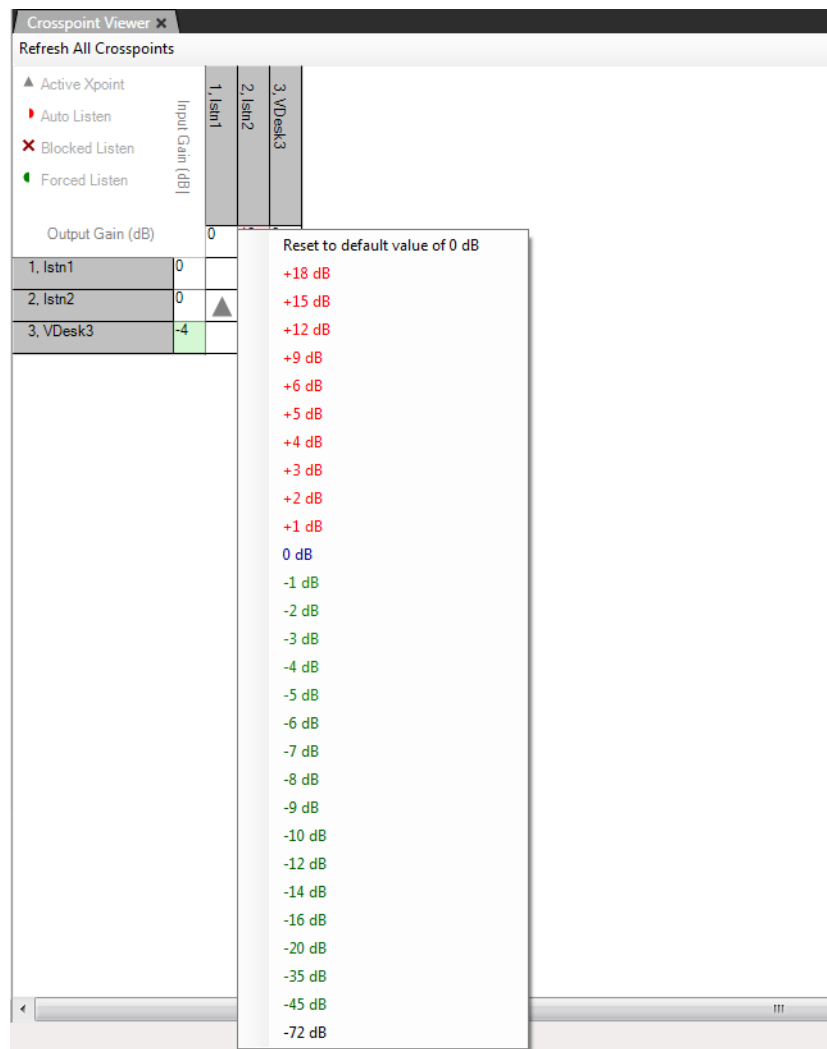

Figure 27-6 Input and Output Gain Settings

You can set the default port gain using the individual port settings on the Cards & Ports screen. The setting is applied to the matrix as part of the map and is displayed by the crosspoint monitor.

- 8) Right-click the port gain setting to display the gain levels and show this value as the default setting so the port may be reset to the EHX value at any time without applying a new map and a reset.

If the port gain is set to a non-zero level in EHX and then set to zero using the crosspoint monitor the gain is shown highlighted in light blue to indicate that the zero value is not the default value in the map.

27.1.1 Crosspoint settings and averaging

In some cases, the same port may be placed on a panel as different key more than once, for example on different shift pages (multiple instances of the port). If these instances of the port or keys have been set up with different audio levels then the level used on any of keys connected to the port is the average of the levels of all the instances on the panel. This is to prevent a situation where the audio level from the same port may vary greatly between different keys assigned to that port depending on how the different keys have been set up.

To improve the performance of the level averaging on i-Series panels the crosspoint range for these panels is larger than previously. The preset levels in the matrix for i-Series panels are:

- -30.2 dB
- -24.1 dB
- -18.1 dB
- -12.1 dB
- -9.2 dB
- -6.0 dB
- -3.9 dB
- -2.1 dB
- 0 dB
- 1.1 dB
- 2.1 dB
- 3.2 dB
- 3.9 dB
- 6.0 dB
- 8.9 dB
- 12.1 dB

The range for V-Series panels is -72 dB to +12 dB.

27.2 Matrix event log

In Live mode, messages are displayed in the Matrix Event Log as soon as they are generated by the matrix. In Historic mode, EHX makes a connection to the database. The user sets search criteria and the resulting messages are displayed on screen.

The Matrix Event Log gives the EHX user information about the state of the matrix that is helpful in diagnosing and repairing problems.

- 1) Select **Diagnostics > Event Log**.
- 2) Select the event types to be logged in the **Properties** pane by clicking on the required checkboxes. The message types that can be selected for logging are Critical, Warning and Information.
- 3) Set the logging mode to **Live** to report current messages, or **Historic** to display previous logged messages. In **Historic** mode the specific hour, minute, and second beginning and end dates to search can be set. Click **Display** when these parameters have been set to display the required log messages.

As soon as EHX is opened, it will log status messages in the background for any matrices in the active project.

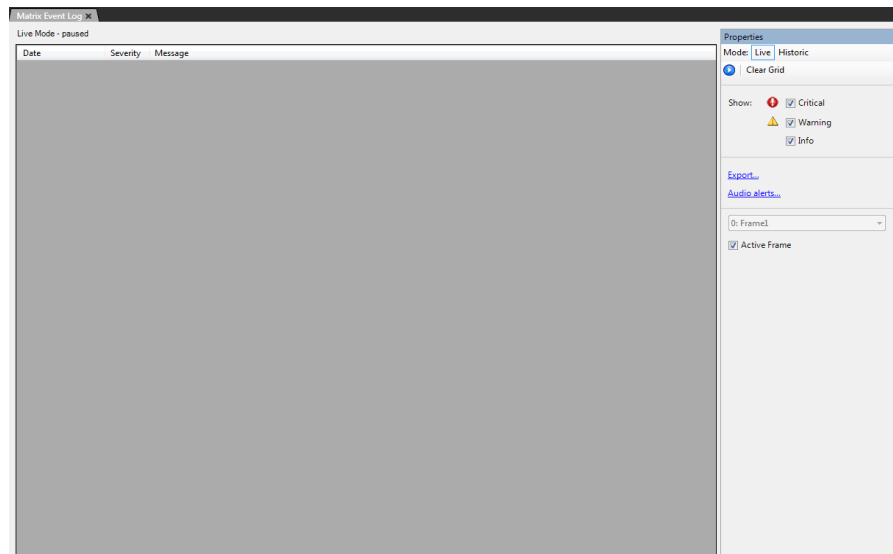

Figure 27-7 Event Log

- 4) Use the **Export** option in the **Properties** pane to export the log messages to a file for further processing.

Note: The logging export file is an XML file and can be imported into Excel using the speech quotes (") as the delimiter.

27.2.1 Request info

- 1) Select **Request Info** in the Properties pane to display a **Request Matrix Information** screen which allows a number of matrix parameters to be set or displayed.

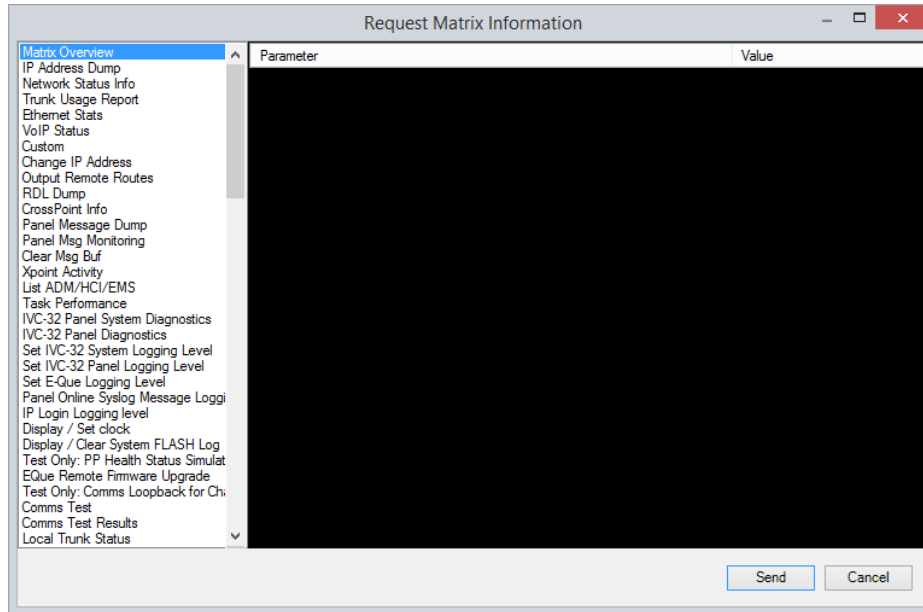

Figure 27-8 Request Matrix Information

- 2) Select the required function in the left pane and the click on the **Send** button to send the request or update.

The default functions are described below.

Matrix overview

Select this option to cause information about the current matrix status to be output to the matrix event log.

IP address dump

Select this option to output information on the current matrix IP address information to the event log.

Network status info

Select this option to output the current network status of the matrix to the matrix event log.

Ethernet stats

Select this option to output the statistics of Ethernet transactions logged such as packet losses to the matrix event log.

Change IP address

- 1) Select this option to allow the primary and redundant IP address of the target matrix to be set. These addresses correspond to the LAN1 and LAN2 connectors on the rear of the CPU card (see the **Eclipse HX-Omega**, **Eclipse HX-Median** and **Eclipse HX-Delta User Guides**) or the Eclipse HX-PiCo unit (LAN 1 only).

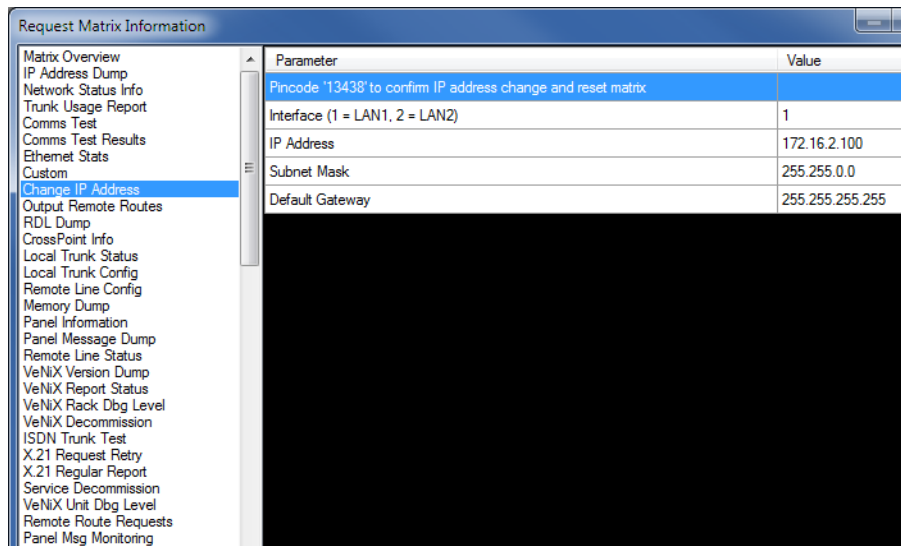

Figure 27-9 IP Address Setup Display

- 2) Select interface 1 or 2 (LAN1 or LAN2 port) and enter the required IP address, subnet mask and default gateway and click on **Send** to update the matrix.

Note: Changing the IP address parameters may result in the EHX PC losing contact with the matrix and may require the Ethernet configuration of the PC to be changed.

Custom

Select this option to allow request parameters to be entered manually for applying to the matrix.

27.2.2 Audio alerts

Select this option in the **Properties** pane to allow audio alert sounds to be set up for the three message types of Critical, Warning and Informatory. The audio alerts are .wav files and the default is the standard Windows media files. You can configure other sound files if required.

Click to select one or all of the following categories of messages to cause an audio alert from the EHX computer.

- Critical
- Warning
- Info

If no option is selected, no event in this category of messages causes an audio alert.

27.3 Wireless status

The EHX Configuration Software now offers a wireless diagnostics screens that shows:

- Live transceiver/beltpack associations
- Live status and performance indicators (metrics) for beltpacks and transceivers.

27.3.1 The transceiver/beltpack association grid

To see wireless diagnostics, navigate to **Diagnostics>Wireless Status** in the EHX Configuration Software.

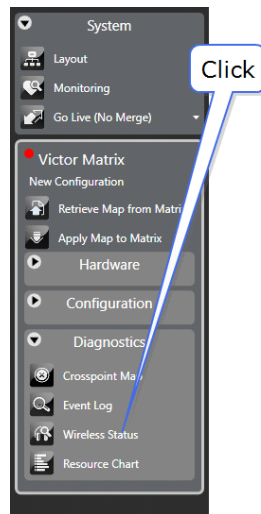

Click here to see **Beltpack Telemetry Screen**

Hover your mouse here for beltpack details

These transceivers are registered in the matrix map

Hover here for IPT metrics

These beltpacks are registered in the matrix map

This beltpack is registered in the matrix map, is powered on and is connected to the IPT. It also has a Role assigned to it.

This beltpack is registered, powered and connected. It is not usable until it is given a role.

Sort by beltpack **Role** or beltpack **ID**

General status bar

Battery life

RSSI and FER

Indicator	Indicator meaning
General status bar	Turns amber/red on: <ul style="list-style-type: none"> • Low battery • Low signal strength • High error rate
Battery	For lithium batteries: <ul style="list-style-type: none"> • Amber: 16% battery, ~2 hours life remaining • Red: 8% battery, ~1 hour life remaining
Received Signal Strength Indicator (RSSI)	<ul style="list-style-type: none"> • Amber: RSSI below 40 • Red: RSSI below 30 RSSI must be above 30 for audio to work reliably.

Indicator	Indicator meaning
Frame Error Rate (FER)	<p>FER should be close to 0. Unsatisfactory FER is shown by a colored rectangle:</p> <ul style="list-style-type: none"> Amber: 10% Red: 20%

Group, filter and search beltacks:

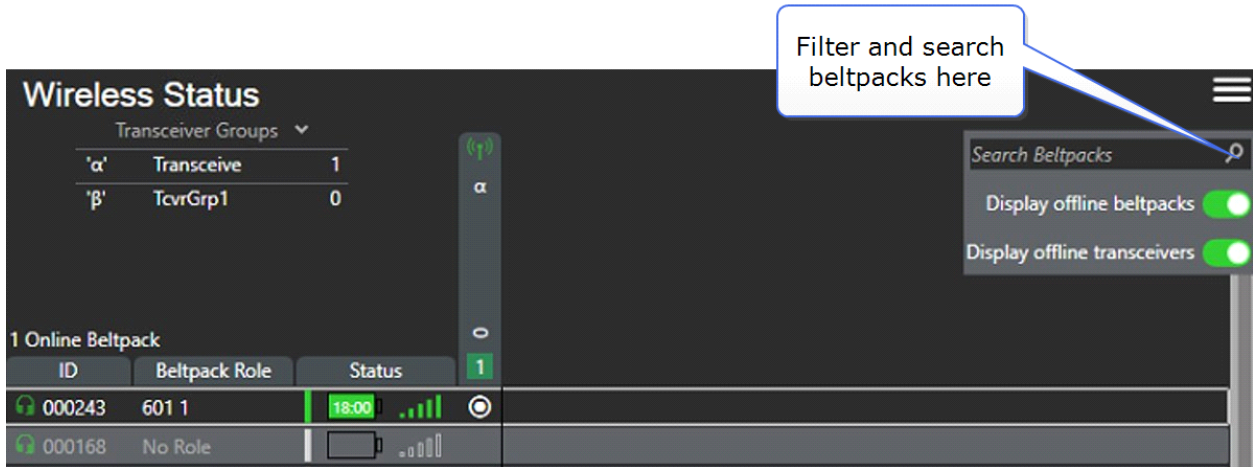

27.3.2 Beltpack Telemetry Screen

Note: EHX must be connected to the system at all time to collect necessary data and avoid gaps in telemetry

This screen shows a graphic representation (live and historic) of the beltpack **Event Log**. It can be used for both quick diagnosis of problems and advanced troubleshooting. Reach this screen by clicking on any beltpack row in the **Wireless Diagnostics** screen.

- Use the mouse scroll wheel to zoom in. The zoom focus is located on the mouse pointer.
- Left click on any line for information about that data point (including transceiver slot).
- Turn on **Live Logging** on an individual IPT for detailed RSSI and FER logging. The increased logging is not recommended for normal operation but can be useful during site survey and initial set up or for fault finding with a specific transceiver.
- Use the **Options** button to change the display options.

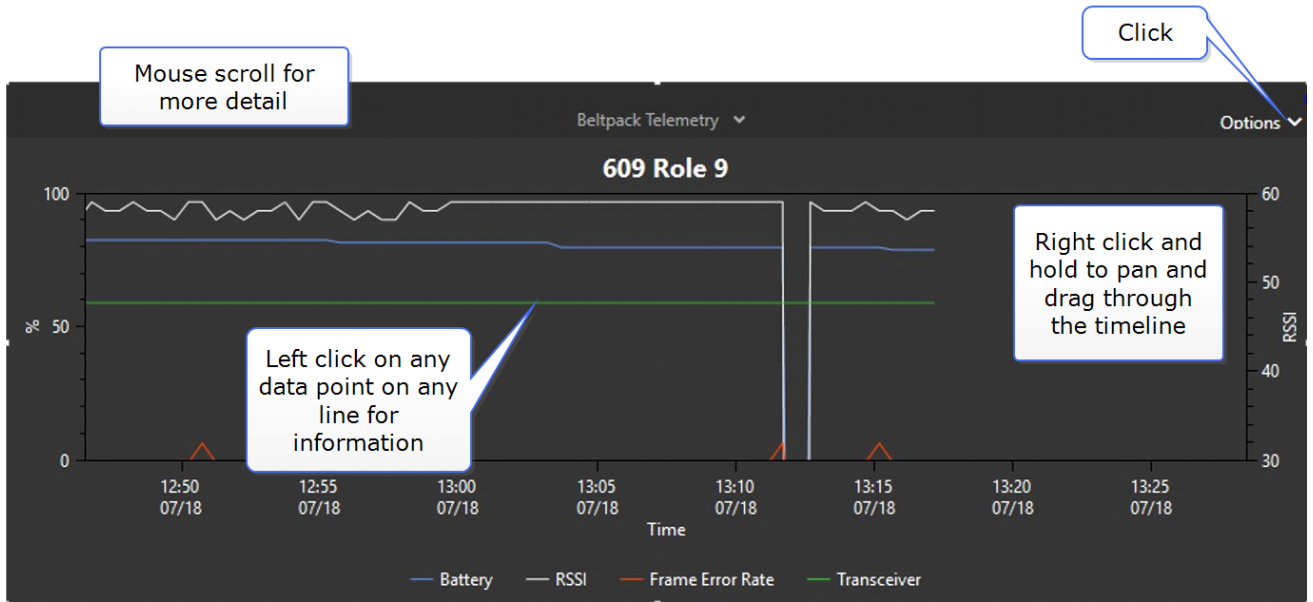

Live Logging

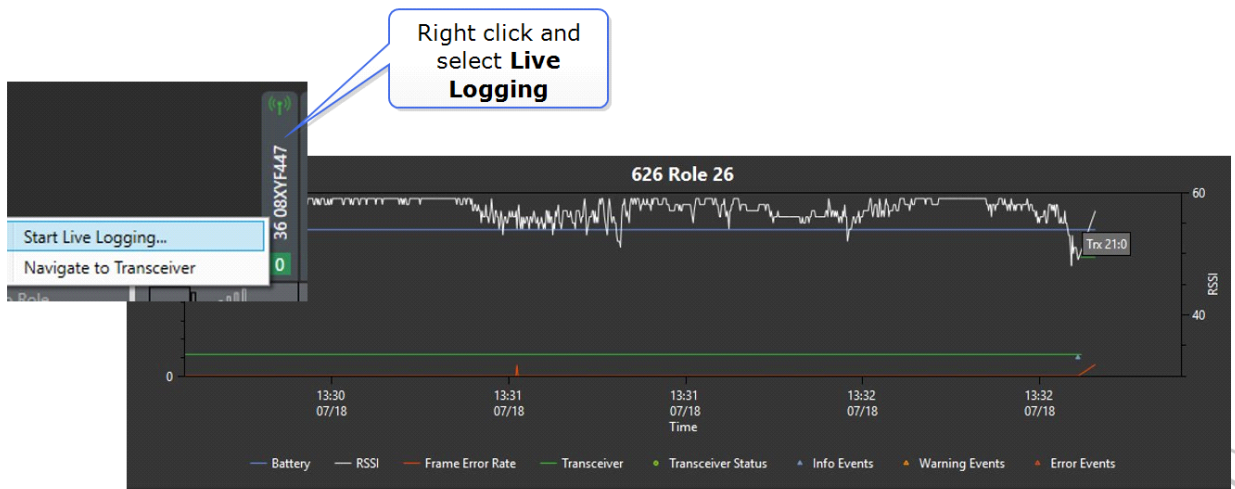

Live Logging increases data reporting from once every 30 seconds to once a second. Not recommended for normal use.

27.4 System monitoring

To start system monitoring:

- 1) Select **System > Monitoring**.

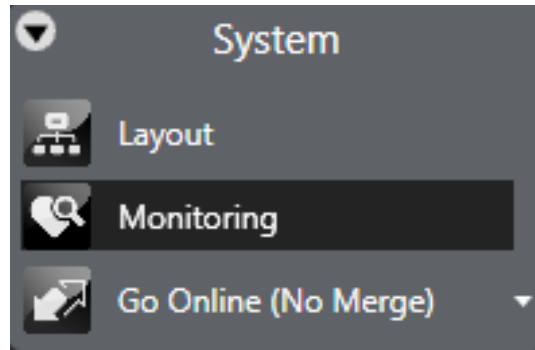

Figure 27-10 System Menu

Monitoring displays all the matrices in the current configuration and their status.

The matrix monitoring state is also shown in the EHX sidebar if the monitoring screen is open.

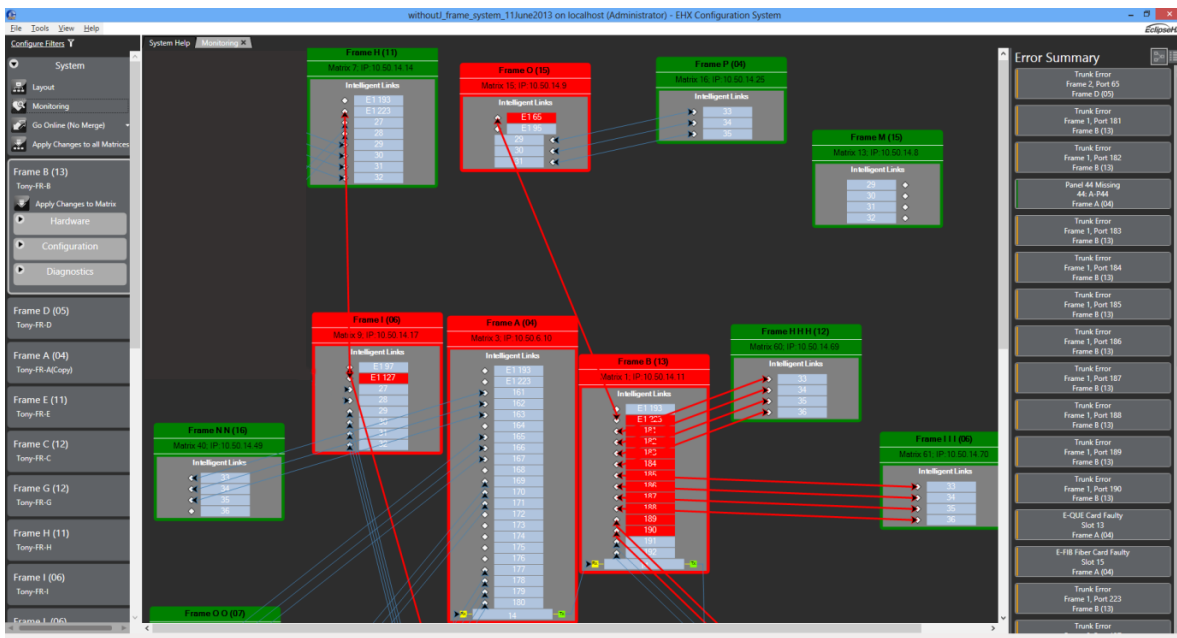

Figure 27-11 System Monitoring Screen

On the monitoring screen, all trunks are coloured light blue. Trunk lines that are detected as being in error as coloured red, and those that are detected as being in use in are colored blue. If EHX detects that only one end of a trunk is in error (a trunk card has been pulled on one of the matrices), the trunk is coloured red, as is the node on the matrix that is in error.

Color coding is used to indicate system status, according to the following key:

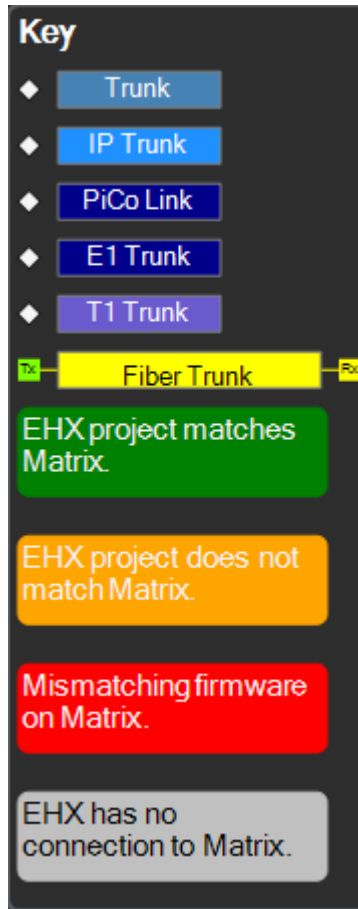

Figure 27-12 System Monitoring key

An error summary is listed in the right-hand side of the **Monitoring** screen.

- 2) Select the **Detailed** button in the top-right of the **Monitoring** screen to switch to an alternate view of the same information. This provides a detailed tree view of the system. You can filter information for matrix, error type or error priority.

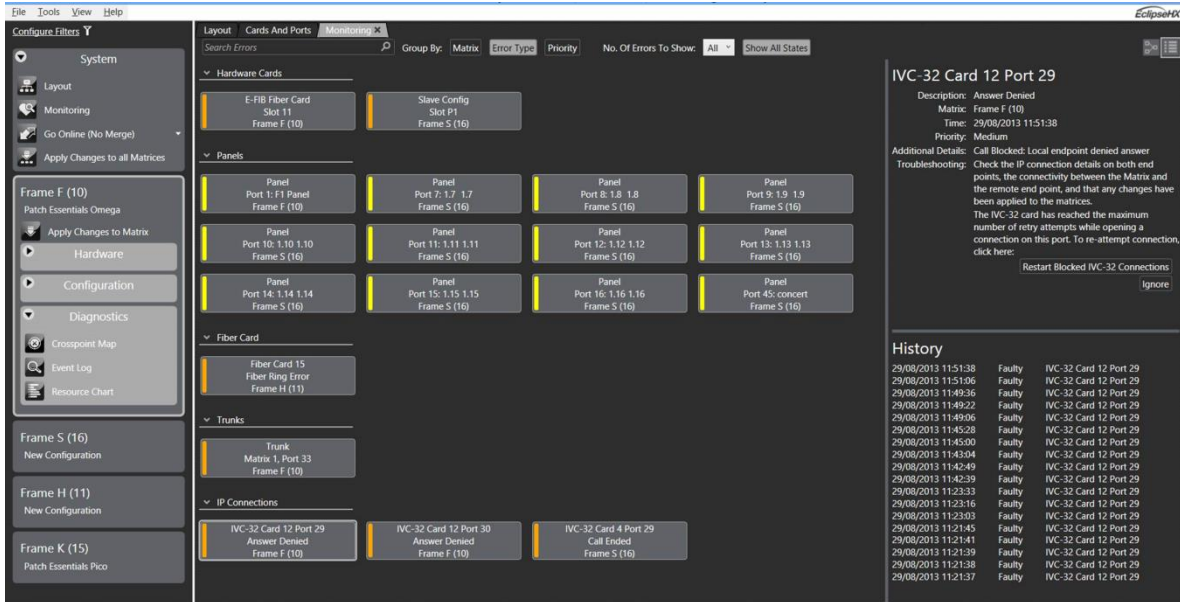

Figure 27-13 Detailed system monitoring view

If an error is selected, the right-hand side of the monitoring screen shows detailed information about that error, including any additional details that might be available and a short troubleshooting guide. A history of the state of the error is also shown, so you can see when this fault happened and whether it has happened previously.

- 3) You can ignore errors by right clicking on them in the error list (in either overview or detailed view) and selecting **Ignore** from the context menu. There is also an **Ignore** button shown in the details for each error.

27.5 E-DANTE-HX interface card

This part of the monitoring screen gives you information about the E-DANTE-HX interface cards. It also shows you the LAN status of primary and secondary connections. Examples appear below:

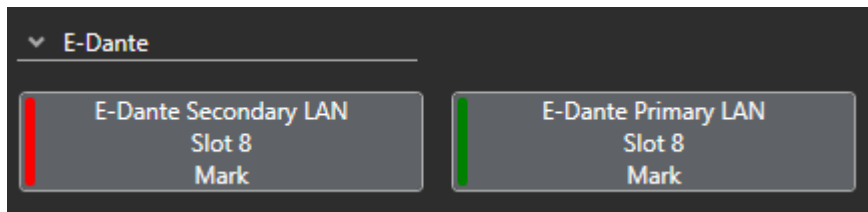

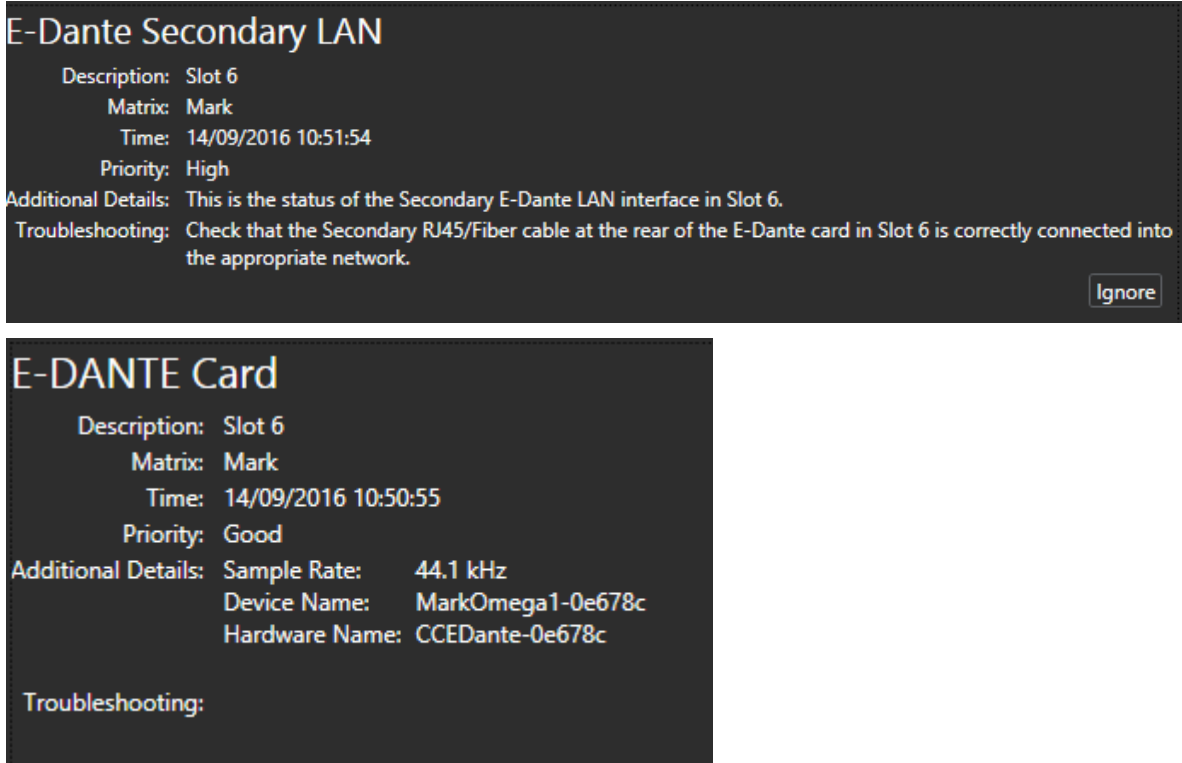

Figure 27-14 E-DANTE monitoring

In this dialog box you can see the hardware name and device name for the card. The hardware name cannot be changed and uniquely identifies that card. The device name can be changed in the Dante Controller.

If a card is removed from the matrix, and another inserted with a different hardware or device name, an error will be indicated on the front of the card. This notifies the engineer that the Dante network routes have changed, and the routes may need to be reconfigured using the Dante controller.

For more information on related error reporting, see section **14.8.3 Redundancy options**.

27.6 Resource chart

The Resource Chart allows you to view the system resources that would be used by your current configuration if it were to be applied to the matrices.

When you build the current configuration for the Resource Chart, the system resources are displayed as a percentage of the maximum permitted value.

Color coding indicates the different usage levels:

- **Green** = Low usage.
- **Amber** = Medium usage.
- **Red** = High usage.

Select **Diagnostics > Resource Chart**.

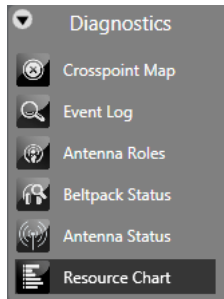

Figure 27-15 Resource Chart

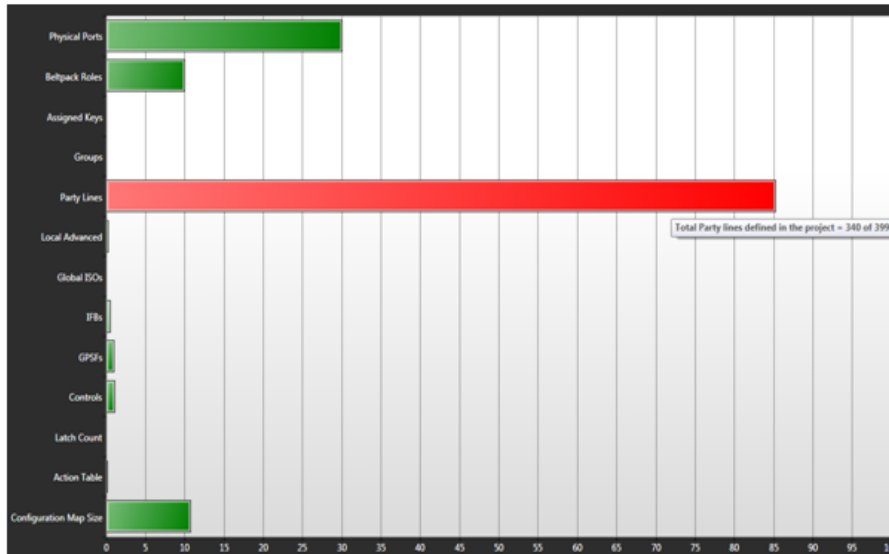

Figure 27-16 Example resource chart

27.7 Save diagnostics information utility

The **Save Diagnostics Information** utility (**Help > Save Diagnostics**) takes a snapshot of the current state of your configuration, the EHX PC and the matrices, and store this information as a compressed file on your computer.

This information can then be sent to Clear-Com support to assist with the diagnosis of issues.

The following information is captured:

Information captured	Description / comments
EHX version information	The version of EHX that is being run, the address of the server that EHX is connected to, and the operational mode of EHX (Client-Only or Client-Server).
EHX Project (configuration)	Exported as a *.hxn file.
EHX Database	A copy of the EHX database is provided, if available.
Matrix information	The name, ID, description and IP address of the matrices in the current project, along with details of their active configurations.
Firmware report(s)	A firmware report from each of the matrices in the current project.
Configurations currently running on the matrices	Copies of the configurations that are currently running on the matrices (achieved by performing an upload from each of the matrices in the current project).
EHX PC system Information.	Basic system information concerning the EHX PC, including OS and hardware information.
EHX PC process information	Information about the processes that are currently running on the EHX PC.
EHX PC service information	Information about the services that are configured on the EHX PC.
EHX exception logs	The exception logs from EHX
EHX event logs	The event logs from EHX
Matrix diagnostics information	A dump of engineering diagnostics information from the matrices (including system information, fiber allocation, IP and Ethernet usage, and task performance history)

Table 27-1 Save Diagnostics Info Utility

27.8 Clear unused memory

The .Net Framework used by EHX manages its own memory usage on the system, allocating and releasing memory when appropriate. In some circumstances, rather than release unused memory back to the operating system, it may choose to hold on to the memory allocation if it believes it will be used again in the near future. The **Clear Unused Memory** option under **Help** causes EHX to ask the .Net

Framework to release any unused memory, even if it may be used in the future. In general, EHX and .Net manage the memory allocation without any issues - this option should only be used if you believe that EHX is leaking memory (progressively using more and more memory) and wishes to get a more accurate view of the memory usage.

27.9 Matrix event log and save diagnostics

The matrix event log is stored in a database file named `EHXDataStore.sdf`. To prevent this file from filling all available storage it is scrubbed daily, by default removing all records older than 1 week.

These records are backed up to the user's AppData folder:

- **In client only mode:** `C:\Users\\AppData\Roaming\Clearcom\EHX Configuration System\logs`
- **In client server:** `C:\Users\EHXServer\AppData\Roaming\Clearcom\EHX Configuration System\logs.`

This folder will require intervention from time to time to control the size of the stored data. Save diagnostics will include these scrubbed records in any report, if they are available.

28 Glossary

The glossary gives a brief explanation of some of the main terms that you might encounter in this User Guide.

Agent-IC remote client

An App that runs on iOS and Android phones and tablets as a remote panel.

Alias label

A label that is temporarily assigned and replaces a previously labeled port or conference.

Analog Port

Any of the Eclipse HX matrix's analog input/output RJ-45 connectors that are used to connect cable from the matrix to panels and interfaces. Each port connects to a separate audio channel in the matrix intercom system.

Antenna/transceiver

A fixed unit that can receive and transmit RF signals to wireless belt packs. Used in wireless partyline systems such as FreeSpeak II.

Bus

A bus is the channel or path between the components in the matrix along which electrical signals flow to carry information from one component to the next. In the Eclipse HX matrix the bus is located in the etched surface of the midplane.

Call Signal

A call signal is an electronic signal sent from one panel or interface to another. A call signal can be audible and/or visual. Typically, a call signal is sent to get the attention of a panel operator who may have turned down their intercom speaker's volume or removed their headset. It can also be sent to activate an electronic relay.

Canvas

The assignment area of Dynam-EC which can have any user labeled background.

Category-5 cable

EIA/TIA 568 category specification relating to network cabling. Shielded category-5 cabling or above is required for Eclipse HX matrix wiring.

CellCom®

Digital wireless communications product. Sold under the CellCom name in USA and as FreeSpeak in Europe and Asia.

Central Matrix

The term central matrix is used to differentiate the central hardware and software of the intercom system from the connected audio devices. The central matrix consists of:

- The metal housing for the circuit cards and power supplies.
- The circuit cards.

- The power supplies.
- The rear panel connectors which connect the matrix's hardware to panels and interfaces.

Concert

Concert provides a secure and scalable solution for providing high quality voice communication between single or multi-site facilities over an IP infrastructure.

Conference

An internal matrix virtual party line or busbar where many panels and interfaces can talk onto or listen from the party line without talking to themselves.

Configuration.

Determines the operating parameters of the Eclipse HX matrix system, including port functions, talk-and-listen audio routes, controls and other functions. Configurations are created and managed in EHX, for applying to the matrices.

Destination

A device such as an intercom panel, beltpack, or interface to which audio signals are sent. The device from which audio signals are sent is called a source.

Duplex

All real-time communication between individuals talking face to face is full duplex, meaning that they can both talk and listen simultaneously. The Eclipse HX matrices provide full-duplex audio.

E-DANTE64-HX

A matrix interface card that is enabled to work with Dante network protocols and software, allowing you to transport many channels of high quality audio via a Clear-Com matrix to multiple Dante enabled devices using standard Ethernet network structure (up to 64 channels per E-DANTE64 card).

EHX

Eclipse HX Configuration Software. Software program that guides the operation of the central matrix circuit cards and connected panels.

E-IPA-HX

A high capacity internet protocol (IP) audio card. It provides up to 64 connections, doubling the port/beltpack connections of the current IVC-32 card.

Ethernet

International standard which describes how information is transmitted across a network. Provides for the efficient organization of network components.

Fiber-optic Cable

A fiber-optic cable consists of a glass core covered with a reflective material called cladding and several layers of buffer coating to protect the cable from the environment. A laser sends light pulses through the glass core to the other end of the cable.

FreeSpeak®

Digital wireless communications product. Sold under the FreeSpeak name in Europe and Asia and CellCom name in USA.

FreeSpeak II™

Advanced digital wireless communications product.

Full Duplex

Refers to transmission of signals in two directions simultaneously.

Hosted Direct

An IVC-32 port function that is used when one or two additional IP ports are configured on a panel.

IFB

Interruptible Foldback. The term foldback refers to sending program audio, or some other audio mix, back to announcers while they are on the air. Doing so allows announcers to monitor themselves, other announcers, videotapes of commercials, or some mix of sources, while they on the air. This is typically found in television news and live broadcast events.

Announcers typically wear a small ear piece so they can hear the selected foldback audio mix. When a director wants to give directions to an announcer on air, or to announce changes in the program, the director must interrupt the foldback. To do this, the director uses a channel specifically set up to interrupt the foldback audio.

Interface Module

A piece of electronic hardware designed to convert the four-wire signals of a central matrix port to some other form of communication, such as 2-wire party line, telephone, etc. The interface module is connected to a central matrix port. The external non-four-wire device is then connected to the interface module.

ISO

The ISO function, short for panel ISOLation, allows a panel operator to call a destination and interrupt all that destination's other audio paths and establish a private conversation. When the call is completed the destination's audio pathways are restored to their original state before the interruption.

Key Group

Key Groups provide a way of assigning a label to multiple panels simultaneously even within a networked matrix system. Once the Key Groups have been defined using EHX, all the keys within a Key Group can be changed with a single assignment in Dynam-EC.

Label

A label is an alphanumeric name of up to five characters that identifies a source, destination, or control function accessed by an intercom panel. Labels appear in the displays of the intercom panel. Labels can identify panels, ports interfaced to other external equipment, fixed groups, party lines, and special control functions.

Multiplexing

The process by which two or more signals are transmitted over a single communications channel. Examples include time division and wavelength division multiplexing.

Non-volatile Memory

Data stored in the CPU's firmware (ROM) that is not lost when the power is turned off.

Over The Air Registration

A way to register a FreeSpeak II beltpack without requiring a wired connection.

Palette

The port, keyGroup and Monitor selection screen in Dynam-EC.

Panel

Also referred to as station in some cases (usually older manuals). Any intelligent intercom device connected to the rear-panel analog ports of the central matrix. This term does not refer to devices connected through interface modules.

Partyline

A wired shared communication system based on a single screened pair of wires.

Port

Any of the input/output connections (RJ-45 connectors) on the back panel of the central matrix. These connectors and the attached cables connect the central matrix to remote intercom devices. The term port emphasizes that the connection is a portal between the central matrix and the remote intercom devices.

Program

Any separate audio source that is fed into the intercom channels. In television applications, for example, program audio is the audio that is broadcast on air.

Project

A **project** (stored and exported as an ***.hxn** file) provides a container for your configurations, and may comprise one or many configurations for one or many matrices.

A project can be used to define every aspect of a complex intercom system, including the connectivity between multiple, intelligently linked matrices and/or the configurations for individual matrices.

Rack Unit or RU

Standardized unit of mounting space on a rack panel. Each rack unit is 1.75 inches (44.45 mm) of vertical mounting space. Therefore 1 RU is 1.75 inches (44.45 mm) of vertical mounting space, 2 RU is 3.5 inches (88.9 mm), 3 RU is 5.25 inches (133.35 mm), and so on.

Remote Panel

Any intelligent intercom device connected to the back-panel ports of the central matrix. This term does not refer to devices connected through interfaces.

Sidetone

The sound of the panel operator's own voice heard in their own earphone as they speak.

SIP Client

A SIP client is any network device that sends SIP requests and receives SIP responses.

Source

In this manual, the term source refers to a device—such as an intercom panel, interface, or beltpack—that sends audio into the matrix. The device to which audio is sent is called a destination.

TEL-14

A digital telephony interface module.

VOX

In the Eclipse HX system, when audio at a panel exceeds a threshold, a light switches on at the panel's port card to visually cue the operator. The threshold level is set in the Eclipse HX Configuration Software.

V-Series

Communications panels used with Eclipse HX systems providing advanced facilities. Available in rack mount and desktop formats.

29 Limited Warranty

This document details the Clear-Com Standard Limited Warranty for all new products for sale within all regions with the exception of Military, Aerospace, and Government (MAG).

EXCEPT AS SET FORTH HEREIN ("LIMITED WARRANTY"), CLEAR-COM MAKES NO OTHER WARRANTIES, EXPRESS, IMPLIED OR STATUTORY, INCLUDING WITHOUT LIMITATION ANY WARRANTIES OF MERCHANTABILITY, NONINFRINGEMENT OF THIRD PARTY RIGHTS, OR FITNESS FOR A PARTICULAR PURPOSE, ALL OF WHICH ARE EXPRESSLY DISCLAIMED.

- 1) **Standard Limited Warranty.** Clear-Com warrants its products, including supplied accessories, against defects in material or workmanship for the time periods as set forth below provided it was purchased from an authorized Clear-Com dealer or distributor.

Pursuant to this Limited Warranty, Clear-Com will, at its option:

repair the product using new or refurbished parts, or;

replace the product with a new or refurbished product.

Remedies: In the event of a defect, the rights detailed in 1 (a) are your exclusive remedies. For purposes of this Limited Warranty, "refurbished" means a product or part that has been returned to its original specifications.

Standard Warranty Period (by Product):

- i. All Clear-Com brand systems and products, including backpacks, have a Limited Warranty of two years, with the exception of;
 - 1) Cables, accessories, components & consumable items have a Limited Warranty of 90 days.
 - 2) Any Clear-Com product that has been classified as obsolete at the time of sale has a Limited Warranty of 90 days from sales and will be replaced with the same product or a sales credit will be issued, at the sole discretion of Clear-Com.
 - 3) Headsets, handsets, microphones, and associated spare parts, as well as UHF wireless IFB products, have a Limited Warranty of one year.
 - 4) UHF WBS Analog wireless intercom systems have a Limited Warranty of three years.

- 5) All software products, including Concert (Client and Server), ECS, Dynam-EC and Logic are warranted for one year and shall substantially conform to published specifications. The media on which the Software is furnished is warranted to be free of defects in material and workmanship (under normal use) for a period of one year.
- 6) Any Clear-Com products that are listed within the last time buy period have the same Limited Warranty for their type 1.i 1 - 1.i.5 as above.

Any Clear-Com product that is repaired or supplied as a replacement under the terms of this Limited Warranty shall inherit the remaining warranty period from the original product.

Standard Warranty Period Start Date

- i. Dealer / Distributor Sales: In view of Dealer or Distributor stocking practices, the Standard Warranty Period for products sold through Dealers or Distributors will commence from the Clear-Com invoice date and will include an automatic extension of three months. Any valid warranty claim within the Standard Warranty Period as determined by the Clear-Com invoice date will be covered without further supporting evidence. All warranty claims after this date must be supported by the Customer's proof of purchase that demonstrates the product is still within the Standard Warranty Period (as detailed in Section 1.c.i above, plus the automatic three month extension) from their purchase date.

Direct Sales: The Standard Warranty Period will commence from the date the product was shipped from Clear-Com to the Customer. The Standard Warranty Period start date for contracts that include commissioning will be the date of the Site Acceptance Test (SAT) or one month from conclusion of the commissioning project, whichever is earlier.

Invalidation of Warranty

- i. This Limited Warranty shall be invalidated if the product's outer case has been opened and internal modifications have been made or damage has occurred, or upon the occurrence of other damage or failure not attributable to normal wear and tear. Authorized modifications with Clear-Com's express written permission will not invalidate the warranty.

Software Updates

- i. Software Updates are released periodically to correct discovered program bugs. During the Warranty Period, software updates are available to Customers free of charge.

Software Upgrades

- i. Software Upgrades include new Features and/or Functional Enhancements and are not included as part of the Standard Warranty but may be purchased at the published rates.

Note: In the absence of a Software Update containing a program correction and no available workaround to mitigate the problem, at the discretion of Service, Sales, Engineering, or Product Management, the Customer may be provided a Software Upgrade under warranty.

- 2) **Exclusions.** Services do not cover damage or failure caused by any occurrence beyond Clear-Com's reasonable control, including without limitation acts of God, fire, flooding, earthquake, lightning, failure of electric power or air conditioning, neglect, misuse, improper operation, war, government regulations, supply shortages, riots, sabotage, terrorism, unauthorized modifications or repair, strikes, labor disputes or any product failure that Clear-Com determines is not a result of failure in the Services provided by Clear-Com. Further Services excluded from this Agreement include: services required due to errors or omissions in Customer purchase orders; installation or maintenance of wiring, circuits, electrical conduits or devices external to the products; replacement or reconditioning of products which, in Clear-Com's opinion cannot be reliably maintained or properly serviced due to excessive wear or deterioration; Customer's failure to maintain the installation site in accordance with the environmental specifications of the products; or service on products removed from the location originally specified by Customer and/or reinstalled without the prior written approval of Clear-Com. Customer will pay Clear-Com's then current published charges to restore such Covered Products to a condition eligible for further service under this Agreement. Clear-Com shall be excused from and shall not be liable for any failure or delay in performance under this Agreement due to the foregoing or any causes beyond its reasonable control.
- 3) **Limitation of Liability. IN NO EVENT WILL CLEAR-COM BE LIABLE UNDER THIS AGREEMENT FOR ANY INDIRECT, SPECIAL, INCIDENTAL OR CONSEQUENTIAL DAMAGES (INCLUDING WITHOUT LIMITATION LOST PROFITS), REGARDLESS OF THE FORM OF ACTION, EVEN IF ADVISED IN ADVANCE OF THE POSSIBILITY OF SUCH DAMAGES.**
- 4) **Assignment.** Neither party may assign this Agreement or any portion thereof without the prior written consent of the other, except in the event

of a merger, sale of all or substantially all of the assets or other corporate reorganization.

- 5) **Ownership of replaced parts or product.** All replaced parts or products become the property of Clear-Com.

- 6) **Entire Agreement.** This Agreement constitutes the entire agreement between the parties with respect to the subject matter hereof, and supersedes all prior or contemporaneous proposals, oral or written, and all other communications between them relating to the subject matter of this Agreement.

30 *Technical Support & Repair Policy*

TECHNICAL SUPPORT POLICY

- 1) Telephone, online, and e-mail technical support will be provided by the Customer Service Center free of charge during the Warranty Period.
- 2) Technical support will be provided free of charge for all software products under the following conditions:
 - a) The application, operating, and embedded software is installed on a product covered by Clear-Com's Limited Warranty, and:
 - i. The software is at the current release level; or,

The software is one (1) version removed from current.

Older versions of software will receive "best-effort" support, but will not be updated to correct reported bugs or add requested functionality.

- 3) For Technical Support:
 - a) North and South America, (incl. Canada, Mexico, and the Caribbean) & US Military:

Hours: 0800 - 1700 Pacific Time
 Days: Monday - Friday
 Tel: +1 510 337 6600
 Email: Support@Clearcom.com

Europe, the Middle East and Africa:

Hours: 0800 - 2000 Central European Time
 Days: Monday - Friday
 Tel: +49 40 853 999 700
 Email: TechnicalSupportEMEA@clearcom.com

Asia-Pacific:

Hours: 0800 - 1700 Pacific Time
 Days: Monday - Friday
 Tel: +1 510 337 6600
 Email: Support@Clearcom.com

- 4) Email Technical Support is available for all Clear-Com branded products free of charge for the life of the product, or two years after a product has been classified as obsolete, whichever comes first. To log or update a request, send an email to: Support@Clearcom.com.

- 5) Support for Distributor and Dealer Sales

- a) Distributors and Dealers may utilize the Customer Service Centers once a system has been installed and commissioned. Clear-Com Systems and Applications Engineers will provide support to the Distributor from the pre-sales stage through to satisfactory installation for new system purchases. Customers will be encouraged to contact their Dealer or Distributor with their installation and technical support enquires rather than using the Customer Service Centers directly.

6) Support for Direct Sales

Customers may utilize the Customer Service Centers once a system has been installed and commissioned by Clear-Com Systems and Applications Engineers, or in the case of project installations, once the Project Team has completed the hand-over to the Support Centers.