

EclipseHX

Matrix Installation Guide

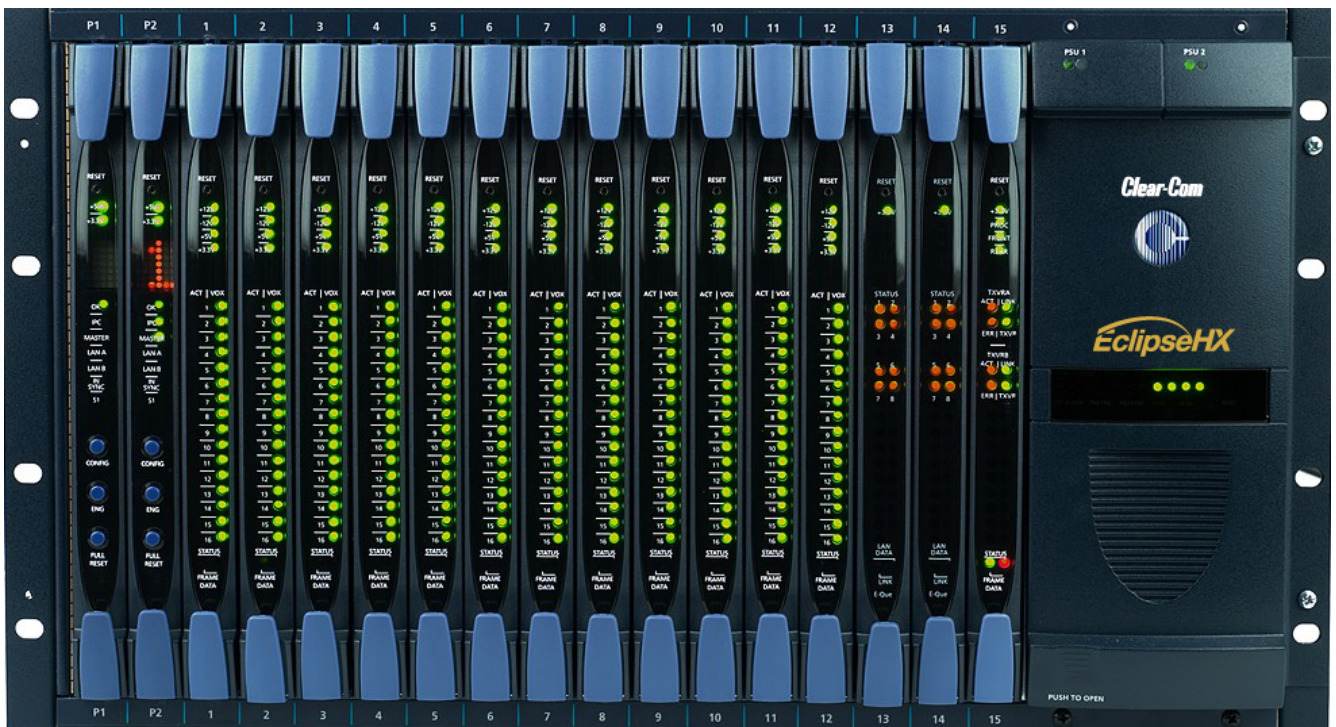

Document Reference

Eclipse HX Matrix Installation Guide

Product Number: 399G101 Revision: A

Legal Disclaimers

Copyright © 2014 HME Clear-Com Ltd

All rights reserved.

Clear-Com, the Clear-Com logo, and Clear-Com Concert are trademarks or registered trademarks of HM Electronics, Inc.

The software described in this document is furnished under a license agreement and may be used only in accordance with the terms of the agreement.

The product described in this document is distributed under licenses restricting its use, copying, distribution, and decompilation/reverse engineering. No part of this document may be reproduced in any form by any means without prior written authorization of Clear-Com, an HME Company.

Clear-Com Offices are located in California, USA; Cambridge, UK; Dubai, UAE, Montreal, Canada; and Beijing, China. Specific addresses and contact information can be found on Clear-Com's corporate website:

www.clearcom.com

Clear-Com Contacts

Americas and Asia-Pacific Headquarters

California, United States

Tel: +1.510.337.6600

Email: CustomerServicesUS@clearcom.com

Europe, Middle East, and Africa Headquarters

Cambridge, United Kingdom

Tel: +44 1223 815000

Email: SalesSupportEMEA@clearcom.com

Canada Office

Quebec, Canada

Tel: +1 (450) 653-9669

China Office

Beijing Representative Office

Beijing, P.R.China

Tel: +8610 65811360/65815577

Contents

1	Important Safety Instructions	6
	Safety symbols	7
	Mains power cord	7
2	Introduction	8
2.1	Summary of Chapters	8
2.2	Further information.....	9
3	Installation Overview	10
3.1	Before installing the system	10
3.1.1	Check the shipment.....	10
3.1.2	Select locations for the system components	10
3.1.3	Determine cabling and wiring scheme requirements	11
3.2	Installing the Eclipse HX system	13
3.2.1	Installing the matrix in a 19" rack.....	13
3.2.2	Installing the cabling	14
3.2.3	Connecting the other system components to the matrix	14
3.2.4	Connecting to mains AC power	14
3.3	After installing the Eclipse HX system.....	15
3.3.1	Configuring the system with EHX software	15
3.3.2	Minimum PC requirements (for EHX software)	15
3.3.3	Recommended PC requirements (for EHX software)	17
3.3.4	Checking the installed system	17
4	Locating System Components	20
4.1	Locating Eclipse HX matrices	20
4.1.1	Locating the Eclipse HX-Omega, Eclipse HX-Median and Eclipse HX-Delta	21
4.1.2	Locating the Eclipse HX-PiCo	22
4.2	Locating interface frame(s) and power supplies	22
4.2.1	IMF-3 interface frame	22
4.2.2	IMF-102 interface frame	23
4.3	Locating user panels	24
4.4	Locating the external computer for EHX	24
5	Powering System Components	25
5.1	Powering matrices.....	25

5.1.1	Eclipse HX-Omega and Eclipse HX-Median	26
5.1.2	Eclipse HX-Delta.....	26
5.1.3	Eclipse HX-PiCo	26
5.2	Powering user panels.....	26
5.2.1	V-Series panels	26
5.2.2	I-Series panels.....	26
5.3	Powering interface frames	27
5.3.1	IMF-3	27
5.3.2	IMF-102	28
5.3.3	Current capacities and consumption	28
6	Wiring System Components	30
6.1	Using RJ-45 connectors.....	30
6.1.1	Cabling standards.....	31
6.1.2	Recommended cables, connectors and wiring tools.....	32
6.1.3	Installing RJ-45 Connectors	32
6.2	Connecting the matrix to a PC running EHX.....	34
6.2.1	Ethernet connection to the PC.....	34
6.2.2	Serial connection to the PC.....	34
6.3	Connecting the matrix to an Ethernet network.....	37
6.4	Connecting the matrix to a PC running Production Maestro Pro	38
6.4.1	LMC-64 interface card	38
6.5	Connecting the matrix to user panels.....	38
6.5.1	4-Pair analog wiring.....	38
6.6	General Purpose Outputs (GPOs)	40
6.7	General Purpose Inputs (GPIs).....	43
6.7.1	Modes for General Purpose Inputs (GPIs).....	45
6.8	E & M signalling with an E-QUE E1 / T1 interface card	47
6.8.1	Example: Ship-to-shore satellite system	47
6.8.2	Enabling E & M signaling on the E-QUE card	48
6.8.3	Using the GPIs / GPOs to trigger actions.....	49
6.9	Connecting the matrix to an external alarm	51
6.9.1	Connecting to the alarm outputs of the PSU-101 power supply	51
6.10	Connecting to a four-wire audio device.....	52
6.11	Connecting to interface modules.....	52
6.11.1	Wiring schemes for the FOR-22 interface module	54
6.11.2	Wiring schemes for the CCI-22 interface module.....	55
6.11.3	Error! Bookmark not defined.
6.11.4	Figure 21: DB-9M interface I / O connector for CCI-22.....	Error! Bookmark not defined.

6.11.5	Wiring schemes for TEL-14 interface modules	58
6.11.6	Wiring scheme for the RLY-6 interface module.....	62
6.11.7	Wiring schemes for a GPI-6 Interface module	66
7	Connecting Matrices.....	70
7.1	Intelligent linking.....	70
7.1.1	Intelligent linking with trunk lines	71
7.1.2	Serial port to serial port linking	71
7.2	Linking Eclipse HX-Pico matrices with the PiCo-Link	73
7.3	Tie-line (audio only) linking	74
7.4	E1 / T1 linking	74
7.4.1	E1 trunk connections	75
7.4.2	T1 trunking.....	78
7.5	Fiber-optic linking.....	80
8	Glossary.....	83

1 *Important Safety Instructions*

1. Read these instructions.
2. Keep these instructions.
3. Heed all warnings.
4. Follow all instructions.
5. Do **not** use this apparatus near water.
6. Clean only with dry cloth.
7. Do **not** block any ventilation openings. Install in accordance with the manufacturer's instructions.
8. Do **not** install near any heat sources such as radiators, heat registers, stoves, or other apparatus (including amplifiers) that produce heat.
9. Do **not** defeat the safety purpose of the polarized or grounding-type plug. A polarized plug has two blades and a third grounding prong. The wide blade or the third prong are provided for your safety. If the provided plug does not fit into your outlet, consult an electrician for replacement of the obsolete outlet.
10. Protect the power cord from being walked on or pinched particularly at plugs, convenience receptacles, and the point where they exit from the apparatus.
11. Only use attachments/accessories specified by the manufacturer.
12. Use only with the cart, stand, tripod, bracket, or table specified by the manufacturer, or sold with the apparatus. When a cart is used, use caution when moving the cart/apparatus combination to avoid injury from tip-over.
13. Unplug this apparatus during lightning storms or when unused for long periods of time.
14. Refer all servicing to qualified service personnel. Servicing is required when the apparatus has been damaged in any way, such as power-cord supply or plug is damaged, liquid has been spilled or objects have fallen into the apparatus, the apparatus has been exposed to rain or moisture, does not operate normally, or has been dropped.
15. **Warning:** To reduce the risk of fire or electric shock, do not expose this product to rain or moisture.

Safety symbols

Familiarize yourself with the safety symbols in Figure 1: Safety symbols. These symbols are displayed on the apparatus and warn you of the potential danger of electric shock if the system is used improperly. They also refer you to important operating and maintenance instructions in the product user manual.

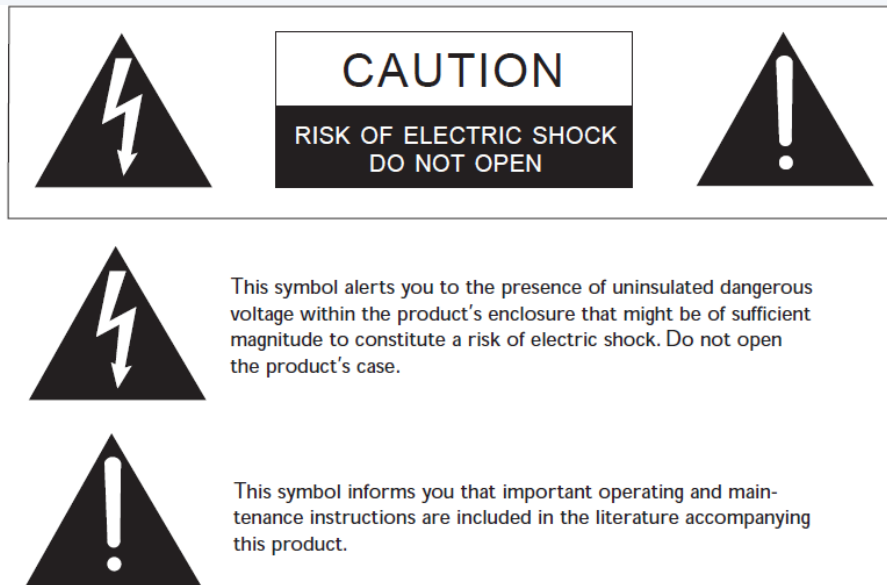

Figure 1: Safety symbols

Mains power cord

Eclipse Matrix devices (matrices) are powered by an internal power supply. The cord to connect the internal power supply to the mains supply must conform to the following:

- The mains power cord shall have an **IEC C13 connector** at one end and a mains power plug at the other end.
- An **IEC C13 plug** has three pins, the centre pin carrying the earth / ground. The other two pins carry neutral and live circuits.
- The conductors of the mains cords shall have adequate cross-sectional area for rated current consumption of the equipment.
- The mains plug that connects to the mains supply must be approved for use in the country where the equipment is to be used.
- The mains power cord must be an **IEC mains power cord** complying with standard **IEC60320; IEC320/C13**.
- Mains power cords used in the U.S. must also comply with standard **UL817**.

2 Introduction

The **EclipseHX** Matrix Installation Guide describes the steps required to install and configure an Eclipse HX matrix system. The Eclipse HX system is a digital point-to-point intercom platform, designed to seamlessly integrate your entire intercom infrastructure (digital, wireless, IP-based and analog intercom systems). The system comprises matrices, interface cards and modules, user panels and interface frames.

The system is configured and managed using the highly intuitive **EHX** software. This guide:

- Provides information about placing, powering, and wiring the hardware system components.
- Defines many of the concepts used in the system.

Note: For more information about **EHX**, see your EHX documentation, including **EHX Help** (integrated with your software).



Servicing instructions are for use by qualified personnel only. To reduce the risk of electric shock, do not perform any servicing other than that described by this guide, unless qualified to do so. Refer all servicing to qualified service personnel.

2.1 Summary of Chapters

Chapter	Summary
3 Installation Overview	Provides a step-by-step installation guide for the components of the Eclipse matrix system, as received from the factory.
4 Locating System Components	Describes the environmental / location requirements for the matrix system components. Includes a summary of component sizes.
5 Powering System Components	Provides guidelines for providing AC power to the system and for planning the powering of interface frames.
6 Wiring System Components	Provides an overview of the various wiring systems for connecting panels and interfaces to the matrix. This chapter contains reference information to help you wire all connectors in the Eclipse HX system. Information on internal jumpers, adjustments, and device specifications can be found in the individual documentation for each component.
7 Connecting	Provides information on connecting different matrices together.

Table 1: Summary of Chapters

2.2 Further information

For more information about any of the Eclipse HX system components (devices) referenced in this guide (including matrices, interface cards, interface modules and software), see the specific documentation for that device or software.

Eclipse HX documentation is available from:

- Your product DVD-ROM.
- The Clear-Com website (<http://www.clearcom.com/product/digital-matrix>).

For sales information, see your Clear-Com sales representative. For contact information, see Page 2 of this guide.

3 *Installation Overview*

This chapter provides a basic overview of the installation process for an Eclipse HX system. The system described in this chapter comprises:

- An **Eclipse HX matrix** (either the 6RU **Eclipse HX-Median** or **Eclipse HX-Omega** or the 3RU **Eclipse HX-Delta** matrices, or the 1RU **Eclipse HX-PiCo** matrix).
- An external computer (PC), which hosts the **Eclipse HX (EHX) configuration software**.
- **Interface modules**, which enable connections with a wide range of intercom systems, from analog and digital intercom systems, to wireless systems and telephone networks.
- **Interface frames**, which are used to host interface modules.
- **User Panels**, from either the **V-Series** or **I-Series** families of user panels.

Note: This chapter is designed for general guidance only. For more detailed information about individual system components, and how to connect them (including wiring schemes), see the rest of this guide.

3.1 **Before installing the system**

3.1.1 **Check the shipment**

When you receive your Eclipse HX matrix system components:

- Inspect the boxes for shipping damage. Report any shipping damage to the carrier.
 - Note:** The Eclipse matrix system distributor is **not** responsible for shipping damage.
- Check that every item on the packing list has been received.
- Check that auxiliary options have been fitted to system components (such as V-Series panels and I-Series panels).
 - Note:** Auxiliary options may also include interface cards (sometimes called expansion cards or intercom panels) for the Eclipse HX-Omega, Eclipse HX-Median and Eclipse HX-Delta matrices. The names of interface cards are displayed on the front and rear cards in each set.
- Save all packing materials (boxes, Styrofoam). If any item has been shipped in error, is malfunctioning, or requires warranty service, use the original packing materials to return that item to Clear-Com.

3.1.2 **Select locations for the system components**

Select locations for the Eclipse HX matrix, interface cards, interface modules, user panels, PC, and any other system components.

The Eclipse HX matrix is the **central connecting point** of the system. All other devices are connected, either directly or indirectly, to the matrix, and this central role must be accounted for in your system topography.

Note: For additional information about locating the Eclipse HX matrix system, see **4Locating System Components**.

3.1.3 Determine cabling and wiring scheme requirements

The Eclipse HX system requires **shielded category-5 (CAT5) cable with RJ-45 connectors**. All Eclipse matrices have built-in RJ-45 connectors.

3.1.3.1 Wiring schemes

Different wiring schemes are required, depending on the intercom device / system component that is being connected.

For example:

System component	Connections
<p>External computer (PC) for EHX</p>	<p>The Eclipse HX configuration software runs on an external computer (PC). The computer is normally connected to the matrix using the LAN1 connector (a standard RJ-45 Ethernet connector).</p> <p>For Eclipse HX-Omega, Eclipse HX-Median and Eclipse HX-PiCo, a ferrite core must be added to the socket end of each Ethernet cable to comply with European EMC standards. A suitable ferrite core is Würth Elektronik part: 74271132.</p> <p>Shielded CAT5 cable is recommended for Electro Magnetic Compliance in EC countries.</p> <p>Note:</p> <p><i>LAN1 is the default connector on the matrix. The LAN2 connector (which is also a standard RJ-45 Ethernet connector) is unconfigured when it leaves the factory and must be enabled in EHX before it can be used.</i></p> <p>Tip: <i>Connecting through an Ethernet network enables one or more matrices to be controlled through one or more computers on a network. For more information, see 6.2 Connecting the matrix to a PC running EHX.</i></p> <p>You can also use the supplied DB-9 cable or a commercially available shielded RS-232 cable. For more information, see 6.2 Connecting the matrix to a PC running EHX.</p> <p>Note:</p> <p><i>The Eclipse HX-Pico uses a special null modem DB9 to 3.5 TRS. The HX-Median / HX-Omega /HX-Delta CPU card uses a straight serial cable.</i></p> <p>If the EHX computer does not have a serial port, but only provides USB connectors, adapters are available from computer parts</p>

	<p>suppliers. However, you will be required to install drivers for USB-to-serial port connections.</p> <p>Important note:</p> <p>Because of compatibility issues with some products, Clear-Com does not recommend the use of USB-to-serial port connections.</p>
<p>User panels (V-Series and I-Series user panels)</p>	<p>An analog connection, using shielded CAT5 4-twisted pair cables with RJ-45 connectors, is the most common way of connecting V-Series user panels and I-Series panels to the matrix.</p> <p>You can use the following alternative methods for connecting V-Series panels:</p> <p>A digital connection, using the AES-6 digital interface module. Coaxial cable is required to connect panels to the AES-6CX rear card.</p> <p>An IP-based connection, using the IVC-32 interface card (fitted to an HX-Median, HX-Omega or HX-Delta matrix). The IVC-32 interface card allows the Eclipse HX matrix to connect to IP enabled V-Series panels over existing WAN / LAN Ethernet cabling infrastructure.</p> <p>The IVC-32 card can add IP connections through an Ethernet switch / router linked to the Ethernet network. For more information about the IVC-32 card, see the: <i>Eclipse HX-Omega, Eclipse HX-Median or Eclipse HX-Delta User Guide.</i></p> <p>Note:</p> <p><i>For each user panel, additional connector wiring may be required, depending on the options and accessories installed.</i></p> <p><i>See 6Wiring System Components in this guide, and the user manual for your panel.</i></p>
<p>Interface modules</p>	<p>Interface modules are connected to the matrix using:</p> <ul style="list-style-type: none"> • Particular wiring schemes (for each module type) on the DB-9 connectors on the rear of the associated interface frame (IMF-3). • Shielded CAT5 4-twisted pair cables with RJ-45 connectors. <p>The RLY-6 and GPI-6 interface modules are connected directly using an RJ-45 connector on the rear of the matrix to the appropriate interface input connector on the interface frame (IMF-3).</p> <p>For more information, see</p> <p>6.11 Connecting to interface modules.</p>

External alarm	<p>Eclipse HX matrices have <i>built-in</i> fault alarm systems.</p> <p>If you want to use an additional remote alarm, relay contacts are available on the rear panel of the matrix.</p> <p>If you want to add an external alarm condition to the matrix alarm system, the same connector on the rear panel alarm I/O will permit an external contact closure to be connected to the matrix alarm system.</p> <p>Shielded cable is recommended for Electro Magnetic Compliance in EC countries.</p>
-----------------------	--

Table 2: Wiring schemes

Note: For more information about RJ-45 connectors and their installation, see: **4Locating System Components**.

For detailed information about wiring schemes, see **6Wiring System Components**.

For more detailed information about the range of interface cards that can be installed to 6RU matrices, see either:

- *The Eclipse HX-Omega User Guide.*
- *The Eclipse HX-Median User Guide.*
- *The Eclipse HX-Delta User Guide.*

3.2 Installing the Eclipse HX system

3.2.1 Installing the matrix in a 19" rack

Install the matrix in a standard Electronics Industry Association 19-inch wide (48.26 cm) equipment rack. Clear-Com recommends installing the matrix to the **center portion** of the rack, allowing easy access to the connectors on the rear of the matrix.

Because of the large number of cables connected to the matrix, you should also plan for the dressing of cables.

Environmental information

The matrix requires adequate ventilation. Leave at least **2 inches (50.8 mm)** of clearance on all sides of the matrix to ensure proper airflow. Do not block ventilation vents.

Check the position of the circuit cards (CPU cards and interface cards), power supplies, and rear connector panels.

Note: For detailed information about installing a particular matrix or interface frame in the rack, see the appropriate guide in the Eclipse HX documentation set. For matrices, see the:

- *Eclipse HX-Omega User Guide.*
- *Eclipse HX-Median User Guide.*
- *Eclipse HX-Delta User Guide.*

- *Eclipse HX-PiCo User Guide.*

For interface frames, see your **IMF-3** or **IMF-102** documentation.

3.2.2 Installing the cabling

Install the intercom cables between the Eclipse HX matrix and the other system components (user panels and interface frames).

Clear-Com recommends that you route cables **before** wiring the connectors to the cables.

Note: For more information about routing cables, see **4Locating System Components**.

3.2.3 Connecting the other system components to the matrix

Connect the system components / devices (such as the external computer for EHX, interface frames and modules, and external alarms) to the matrix.

For a wiring scheme / connection overview, see **3.1.3 Determine cabling and wiring scheme requirements > Wiring schemes** above.

Note: For detailed information about wiring schemes, see **6Wiring System Components**.

3.2.4 Connecting to mains AC power

3.2.4.1 Eclipse HX matrices and interface frames (IMF-3)

Eclipse HX matrices have two separate AC power connectors for two separate power supplies in the system. Either power supply will completely power a system, providing 100% power redundancy. If the two power supplies are connected to different AC power sources and one of the power supplies loses power, the other will continue to operate the system.

AC voltage for the matrices and the **PSU-101** can be **100 - 240 VAC** without any switching or fuse changes.

Each component of the Eclipse HX system requires AC power **except** for the IMF-3 and some interface modules. The IMF-3 requires an external power supply. The XP-type expansion panels receive power from the panels to which they are connected.

If you are installing an IMF-3, install the **DC power cables** that connect the power supply to the matrix. For the matrix and each connected component, install and connect the mains AC power cables.

Note: For further information, see **5Powering System Components**. V-Series panels

Each V-Series panel has an external power supply and a removable cradle to hold the external power supply.

AC voltage for these panels can be **100 - 240 VAC** without any switching or fuse changes.

3.2.4.2 I-Series panels

I-Series panels have internal power supplies, with removable AC power cords. The power supplies are universal, operating over a voltage range of **90 - 245 VAC** and **50 - 60 Hz**. The maximum dissipation is **40 W**.

Note: Each panel must be plugged into an AC source at its location.



Only connect power supply to earthed supply sockets. Ensure that the power supply is routed to avoid sharp bends, hot surfaces, pinches and abrasion. Refer all servicing to qualified service personnel.

For more safety guidance, see the **Safety Instructions** supplied with this product.

3.3 After installing the Eclipse HX system

3.3.1 Configuring the system with EHX software

The Eclipse HX (EHX) configuration software controls the operation of the connected audio devices by sending signals to the CPU and interface cards in the matrix, which then relay the signals to connected audio devices and systems.

Configurations (the operating parameters of complete system setups) are created in EHX.

Up to four complete system configurations can be stored in the CPU card of the Eclipse HX-Median, Eclipse HX-Omega, Eclipse HX-Delta or the CPU of the HX-PiCO. These configurations can be retrieved and activated on the matrix when required.

The external PC that hosts the EHX software can store an almost unlimited number of complete system configurations (the number is only limited by the available memory space on the PC). You can download the configurations to the matrix as required.

When running EHX on Windows operating systems, the client and server can run on separate machines connected over a network. You can use EHX to perform a wide range of configuration tasks, including:

- Assigning labels (names) to ports and user panels.
- Creating point-to-point and fixed group (partyline) communications between connected audio devices.
- Enabling, limiting or disabling features of any connected user panel or card.
- Configuring connections between matrices .

Note: The above list is not definitive. For more information about the capabilities of EHX, see **EHX Help**.

3.3.2 Minimum PC requirements (for EHX software)

Specification	Description / Value
Processor	1 GHz
Memory	1GB RAM
Hard disk	1GB minimum 32 bit, 2GB minimum 64 bit.
Input devices	CD-ROM drive
Display resolution	SVGA
User entry	Keyboard, Mouse

Ports	2 serial ports and/or network IEEE 802.3 Ethernet card
Network	IEEE 802.3 Ethernet card
Operating systems	<p>EHX 7.6 runs on the following versions of Windows:</p> <ul style="list-style-type: none"> • Microsoft Windows 7 (32-bit and 64-bit). • Microsoft Windows 8.1 (32-bit and 64-bit) • Microsoft Windows Server 2008 SP2 (32-bit and 64-bit). • Microsoft Windows Server 2008 R2 (64-bit). <p>Operation on other platforms is no longer supported.</p>

Table 3: Minimum PC requirements

3.3.3 Recommended PC requirements (for EHX software)

Specification	Description / Value
Processor	2GHz or greater for a client. As many cores as possible for a server.
Memory	2GB for client 32 bit. 4GB for client 64 bit. 3GB for server 32 bit. 4GB+ for server 64 bit.
Free space	1GB minimum 32 bit. 2GB minimum 64 bit.
Display resolution	1600 x 1200
Operating systems	EHX 7.6 runs on the following versions of Windows: <ul style="list-style-type: none">• Microsoft Windows 7 (32-bit and 64-bit).• Microsoft Windows 8.1 (32-bit and 64-bit)• Microsoft Windows Server 2008 SP2 (32-bit and 64-bit).• Microsoft Windows Server 2008 R2 (64-bit). Operation on other platforms is no longer supported.

Table 4: Recommended PC requirements

3.3.4 Checking the installed system

After configuring the Eclipse HX system, check that every system component is functioning correctly, including all:

- Control inputs, outputs and audio paths.
- Connections with connected external devices, such as interface modules and User Panels
- Software functions, such as partylines, ISO and IFB functionality.

To assist with testing, the Eclipse HX system is delivered with a fully functional default EHX configuration. You can tailor the configuration, using EHX software, to meet the requirements of your particular installation.

Note: Because each installation is different, it is beyond the scope of this guide to outline in detail all the checks that you must carry out.

3.3.4.1 Checking the matrix

Eclipse HX-Omega, HX-Median and HX-Delta

The LEDs on the front of the CPU card indicate its operational status:

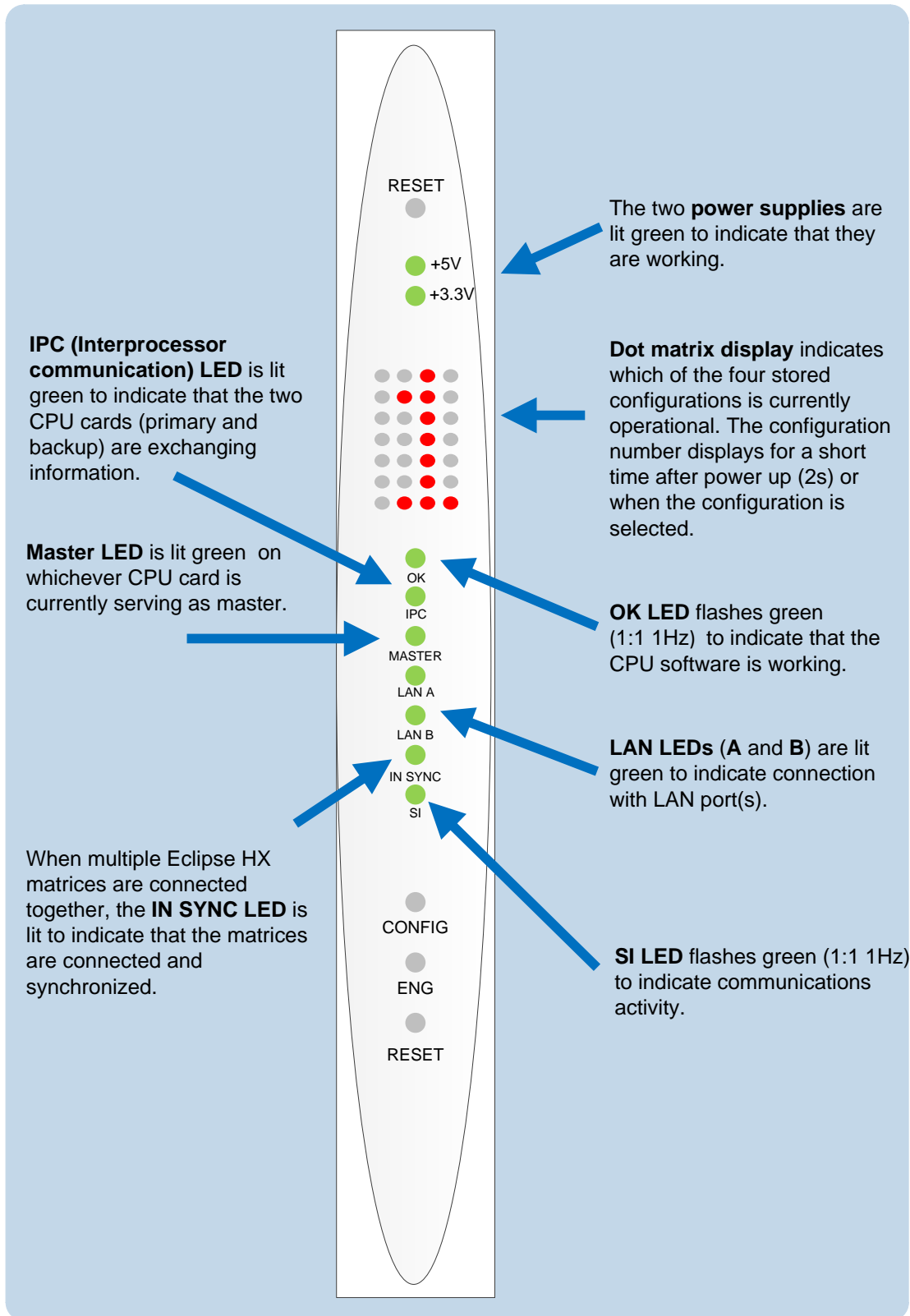

Figure 2: CPU card LEDs

Note: For more information about the lights and controls on the CPU card, see either:

- *The Eclipse HX-Omega User Guide.*
- *The Eclipse HX-Median User Guide.*

- *The Eclipse HX-Delta User Guide*

Eclipse HX-PiCo

The LEDs on the front of the matrix indicate its operational status:

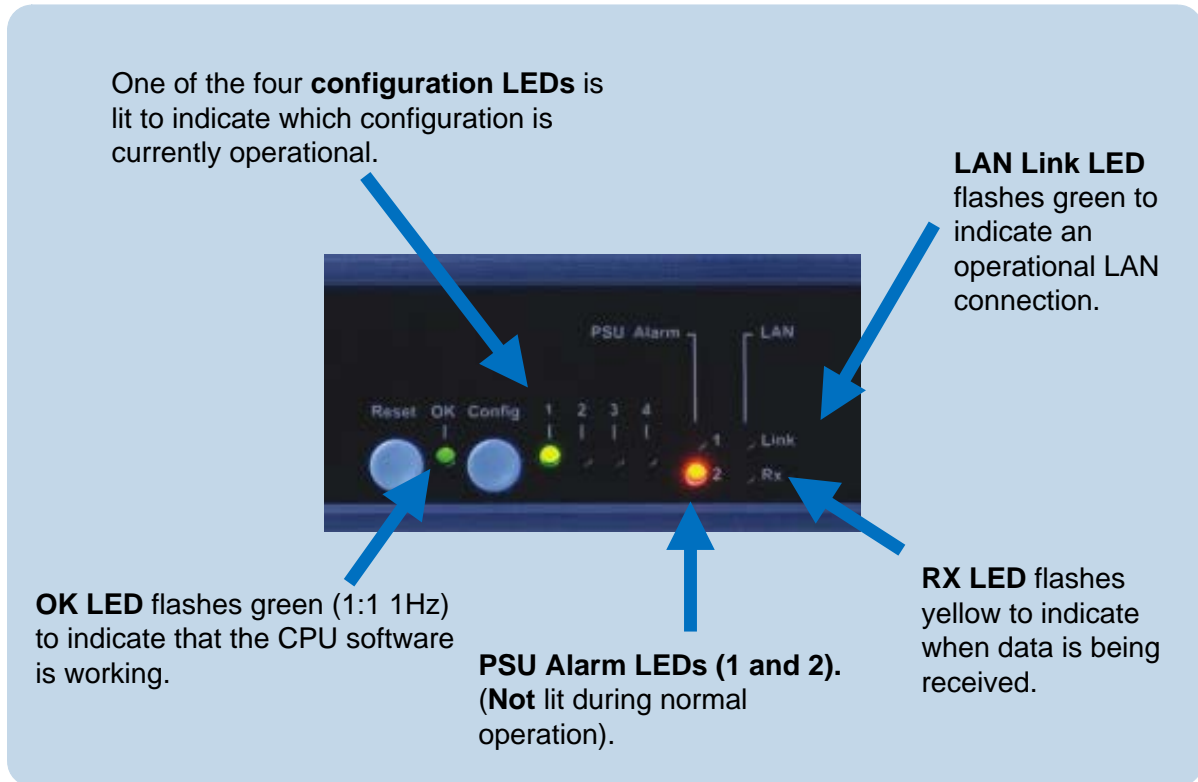

Figure 3: Eclipse HX-PiCo LEDs

Note: For more information about the lights and controls on the front of the Eclipse HX-PiCo, see the **Eclipse HX-PiCo User Guide**.

4 Locating System Components

This chapter provides help with deploying (locating and arranging) the principal components of your Eclipse HX system, including:

- Eclipse HX matrices (Eclipse HX-Omega, Eclipse HX-Median, Eclipse HX-Delta and Eclipse HX-PiCo).
- An external computer (for the EHX configuration software).
- Interface frame(s) (the IMF-3 and IMF-102), which host interface modules.
- User panels (either V-Series or I-Series panels).
- Power supplies.

Note: For an overview of the entire installation process, see **3Installation Overview**.

4.1 Locating Eclipse HX matrices

The Eclipse HX matrices comprise the 6RU Eclipse HX-Omega and Eclipse HX-Median, the 3RU Eclipse HX-Delta and the 1RU Eclipse HX-PiCo.

The Eclipse HX matrix is the **central connecting point** of the system. **All** other devices are connected, either directly or indirectly, to the matrix, and this central role must be accounted for in your deployment planning and cabling topography.

To allow easy access to connectors, ensure that you install the matrix to a central position in the standard **Electronics Industry Association 19-inch wide (48.26 cm) rack**. Because of the potentially large number of cables that may be connected to the matrix, some planning may also be necessary for dressing the cables.

Note: A rack unit (1RU) refers to a standardized unit of space in an Electronics Industry Association equipment rack. One rack unit is 1.75 inches high and 19 inches wide (44.45 mm by 482.6 mm). Each increasing rack unit (1RU) adds 1h.75 inches to the area vertically, while staying at 19 inches horizontally.

4.1.1 Locating the Eclipse HX-Omega, Eclipse HX-Median and Eclipse HX-Delta

The Eclipse HX-Omega and Eclipse HX-Median matrices each require **six vertical rack units (6RU)** (10.5 inches or 267 mm) in a standard Electronics Industry Association 19-inch wide (48.26 cm) rack. The Eclipse HX-Delta matrix requires **three vertical rack units (3RU)** (5.25 inches or 134 mm) in the same 19-inch rack.

4.1.1.1 Cooling the Omega / Median matrix

Each matrix has **two power supplies** (one for redundancy). A modular removable alarm module fitted beneath the two power supplies has two fans that deliver forced air cooling. The primary fan runs continuously. If the temperature in the matrix exceeds a set threshold and extra cooling is required, a secondary fan switches on to increase the air flow in the matrix.

The **fan-on alarm LED** on the front of the alarm module illuminates **red** to indicate that the secondary fan is on. The **red fan-fail alarm LED** illuminates when either fan stops rotating correctly. These alarm LEDs allow the system operator to identify and correct the alarm conditions.

For more information, see the:

- *Eclipse HX-Omega User Guide.*
- *Eclipse HX-Median User Guide*

4.1.1.2 **Environmental information:**

- The air flow through a 6RU matrix from the bottom to the top **must** be unimpeded.
- If other equipment is mounted above and below the matrix that impedes the air flow through the matrix, it will be necessary to leave **1 RU of empty space** above and below the matrix to prevent over-heating.
- If the matrix is mounted in a portable case this air flow must not be impeded.

4.1.1.3 Cooling the Delta matrix

Each matrix has two external power supplies (one for redundancy). A modular removable fan/alarm module at the front of the unit has two fans that deliver forced air cooling. Both fans run continuously, but as the temperature increases, their speed increases to boost the air flow in the matrix.

The **fan fail alarm LEDs** illuminate if the corresponding fan stops rotating correctly. These alarm LEDs allow the system operator to identify and correct the alarm conditions.

For more information, see the

- **Eclipse HX-Delta User Guide**

Environmental information:

- The air flow through an Eclipse HX-Delta, left to right, must not be impeded. The airflow in a standard 19-inch (48.26cm) rack should be sufficient. If the matrix is mounted in a portable case, ensure that the air flow is not impeded.

4.1.2 Locating the Eclipse HX-PiCo

The Eclipse HX-PiCo matrix requires **one vertical rack unit (1RU)** (1.75 in. or 44.45 mm) in a standard Electronics Industry Association 19-inch (48.26 cm) rack.

4.1.2.1 Cooling the matrix

A temperature-controlled fan cools the Eclipse HX-PiCo and forces air through the unit horizontally. An **alarm LED** on the front panel of the Eclipse HX-PiCo alerts the system operator when the temperature-controlled fan activates.

Environmental information:

The air flow across an Eclipse HX-PiCo matrix **must** be unimpeded. The air flow in a standard 19-inch (48.26 cm) rack should be sufficient. If the matrix is mounted in a portable case, be sure the air flow is not impeded.

4.2 Locating interface frame(s) and power supplies

Interface modules convert the four-wire audio signals from the matrix into audio formats for telephones, camera intercoms, two-way radios, analog partyline systems, and other communication devices. In this way, non-four-wire devices can communicate with the matrix.

In addition to 7 slots for circuit cards (CPU and interface cards), the 6RU Eclipse HX-Median matrix has slots for up to 8 interface modules. The 3RU Eclipse HX-Delta matrix has 4 slots for circuit cards, and slots for up to 3 interface modules.

Clear-Com also offers two types of interface frame to host interface modules:

4.2.1 IMF-3 interface frame

The IMF-3 interface frame holds up to **11 interface modules** in **three rack units (3 RU)** of a standard Electronics Industry Association 19-inch wide (48.26 cm) rack.

The frame holds a rear connector panel for each interface module, comprising:

- Two RJ-45 connectors for connecting with the matrix.
- Two DB-9 connectors for connecting cable to non-four-wire devices (see **Figure 5: IMF-3 rear panel**).

4.2.1.1 PSU-101 power supply for the IMF-3

The frame uses an **external PSU-101** rack-mounted power supply to supply power to the interface modules. A second **PSU-101** can be attached for redundancy.

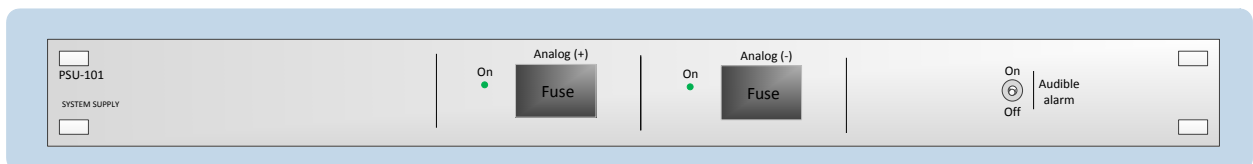

Figure 4: PSU-101 power supply for IMF-3

Note: For more information about the power supply for the IMF-3, see the **Interface Module Frames Instruction Manual**.

4.2.1.2 IMF-3 rear panel

The IMF-3 frame has a rear panel for each interface module. The **layout** of the rear panel is the same for most interface modules. However, the **use** of the rear panel connectors varies according to the type of interface.

To enable easy access to indicators (lights) and controls, locate the interface frame(s) in a convenient location. Interface frames are usually installed near the matrix, but they can be located further away.

The maximum distance between the matrix and the interface frame is **500 feet (150 meters)**.

Eclipse HX matrices have their own power supplies, but do **not** supply power to connected interface frames. A separate power supply (PSU-101) is required for interface modules mounted in IMF-3 frames. If redundant power supply pairs are used for interface modules, mount them together.

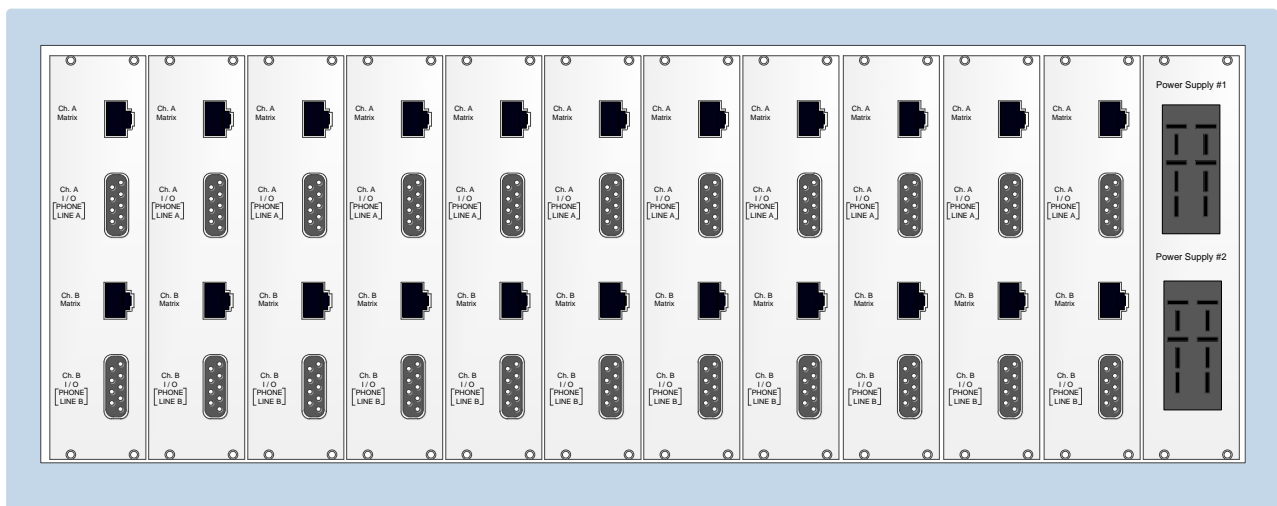

Figure 5: IMF-3 rear panel

Note: For detailed information on power supply requirements, see **5 Powering System Components**.

Environmental information:

An extra rack unit (1RU) (1.75 in. or 44.45 mm) must be left above and below each external power supply unit. This enables cooling for larger system loads.

4.2.2 IMF-102 interface frame

The IMF-102 is a 1RU interface frame, with slots for two interface modules.

The IMF-102 has an internal power supply and a connector for a redundant power supply.

The rear input/output connector panel has two RJ-45 connectors and DB-9 connectors for each of the two interface modules.

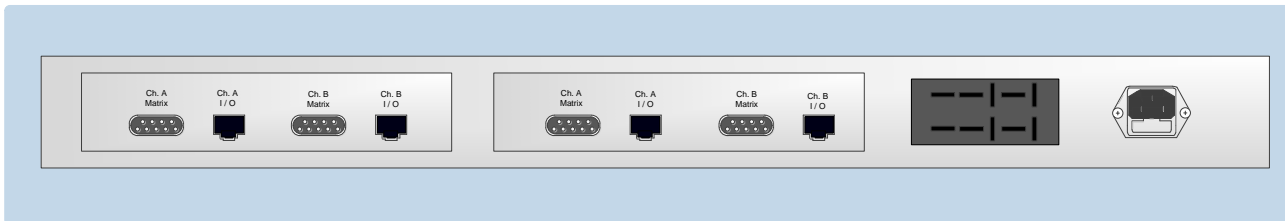

Figure 6: IMF-102 rear panel

4.3 Locating user panels

Locate all user panels (V-Series and I-Series panels) at comfortable heights for operation. To allow for cable connectors, leave at least 2 inches (50.8 mm) of clearance behind the panel chassis. Adjust the brightness of the display to suit your requirements.

Note: To find out more about adjusting the brightness of the display, see your V-Series or I-Series panel manual.

Expansion panels (such as the **V12LDE**, **V12PDE** and **V12RDE**) may be mounted as required.

In terms of cabling, the maximum distance between the matrix and the main user panel is **3000 feet (1000 meters)**.

4.4 Locating the external computer for EHX

The Eclipse HX configuration software runs on an external computer (PC). The computer is normally connected to the matrix using the LAN1 connector (a standard RJ-45 Ethernet connector).

Ethernet connection allows single or multiple PCs to control, configure, monitor, and diagnose single or multiple matrices from anywhere on the WAN / LAN.

For Eclipse HX-Omega, Eclipse HX-Median and Eclipse HX-PiCo, a ferrite core must be added to the socket end of each Ethernet cable to comply with European EMC standards. A suitable ferrite core is **Würth Elektronik part: 74271132**.

Shielded CAT5 cable is recommended for Electro Magnetic Compliance in EC countries.

Note: LAN1 is the default connector on the matrix . The LAN2 connector (which is also a standard RJ-45 Ethernet connector) is **not configured** when it leaves the factory and must be enabled in EHX before it can be used.

You can also connect the external computer to the matrix using a standard PC serial port to DB-9 RS-232 connector. The maximum recommended length of the cable is approximately **10 feet (3.04 meters)**.

Note: The Eclipse HX-Pico uses a special null-modem DB9 to 3.5 TRS. The Eclipse HX-Median / HX-Omega / HX-Delta CPU card uses a straight serial cable.

If the EHX computer does not have a serial port, but only provides USB connectors, adapters are available from computer parts suppliers. However, you will be required to install drivers for USB-to-serial port connections.

Because of differences in PC hardware, operating systems and USB-to-serial converters, Clear-Com cannot provide a recommendation for a specific USB-to-serial converter.

5 Powering System Components

This chapter provides guidance for providing power to the following components of the Eclipse HX system:

- Eclipse HX matrices (Eclipse HX-Omega, Eclipse HX-Median, Eclipse HX-Delta and Eclipse HX-PiCo).
- Interface frame(s) (the IMF-3 and IMF-102), which host interface modules.
- User panels (either V-Series or I-Series panels).

Note: For an overview of the entire installation process, see **3Installation Overview**.

5.1 Powering matrices

The 6RU Eclipse HX-Omega and Eclipse HX-Median and the 1RU Eclipse HX-PiCo are powered by AC mains lines current. The AC mains current provides power to the internal DC power supplies.

The 3RU Eclipse HX-Delta is powered by two external power supplies.

Each matrix is equipped with two power supplies that can be connected to separate branches of AC mains, providing redundancy for both the power supplies and the power sources.

Power failure event	Fail-safe mechanism
One of the two AC power sources fails / is removed	The matrix continues to operate from the second AC power source.
One of the two internal DC power supplies fails	An alarm failure condition is activated, alerting the system administrator to the fact that the failed DC supply must either be replaced or repaired. The second DC supply continues to power the system.

Table 5: Matrix power fail-safe mechanisms

Note: This information is also applicable to the E-32, the immediate predecessor of the Eclipse HX-PiCo.

5.1.1 Eclipse HX-Omega and Eclipse HX-Median

The Eclipse HX-Omega and HX-Median matrices are supplied with two internal Euro Cassette plug-in power supplies. When both power supplies are connected to AC mains power (using the IEC power connectors on the rear panel), the matrix will continue to operate even if one of the AC power sources fails.

A fully equipped Eclipse HX-Omega or HX-Median matrix requires **100 - 240 VAC** at **50 - 60 Hz** with a maximum dissipation of **300 W**.

5.1.2 Eclipse HX-Delta

The Eclipse HX-Delta's power is provided by two external 12V power supply units (for redundancy). The power supplies have separate connections to the rear of the matrix (see Figure 3: Eclipse HX-Delta rear panel).

Each of the power supplies must be connected to a dedicated branch of AC mains power. The matrix will continue to operate even if one of the power supply units fails.

When the matrix is installed to the rack, connect the power cables from the external power supplies to the power connectors on the rear of the matrix.

The power cables connecting the supplies to the matrix are capable of sustaining a pull test of 10 Newtons. The power cables are secured to the matrix by latching connectors.

When the matrix is connected to the power supplies, connect the power supplies to AC mains power. PSU brackets are available that can be mounted to the 19-inch frame. The PSU brackets can be mounted individually or as a pair.

A fully equipped Eclipse HX-Delta matrix (2 CPU cards, 4 interface cards and 3 interface modules) requires 100 - 240 VAC at 50 - 60 Hz with a maximum dissipation of 175W.

5.1.3 Eclipse HX-PiCo

The Eclipse HX-PiCo matrix has two internal power supply units. One power supply unit can power an entire matrix; the second unit provides a backup in case of equipment failure.

In addition, the two supplies have separate IEC connectors to AC mains power, and are designed for completely automatic and transparent changeover between supplies in the event of an outage on one of the AC mains circuits.

The power supplies are universal, operating over a voltage range of **100 - 240 VAC** at **50 - 60 Hz**.

An HX-PiCo requires **100 - 240 VAC** at **50 - 60 Hz** with a maximum dissipation of **40 W**.

Note: The same information is applicable to the E-32, the immediate predecessor of the Eclipse HX-PiCo.

5.2 Powering user panels

5.2.1 V-Series panels

V-Series panels, including expansion panels, have an **external** DC power supply.

The power supply is universal, operating over a voltage range of **100 - 240 VAC** at **50 - 60 Hz**. The maximum dissipation is **50W**.

5.2.2 I-Series panels

I-Series panels have an **internal** power supply, with a removable AC power cable.

The power supply is universal, operating over a voltage range of **90 - 245 VAC** and **50 - 60 Hz**. The maximum dissipation is **40W**.

5.3 Powering interface frames

5.3.1 IMF-3

The IMF-3 interface frame requires an external PSU-101 power supply (see **Figure 4: PSU-101 power supply for IMF-3**).

Usually, **one PSU-101** power supply unit is required for approximately every **two** IMF-3 frames. This requirement may differ where:

- **The IMF-3 is hosting a large number of CCI-22 partyline interface modules**, which require no DC power from the IMF-3 frame (the modules are powered from the partyline connection).

However, even if the IMF-3 only contains CCI-22 interface modules, a PSU-101 power supply is still required to power the circuitry on the rear panel of the IMF-3.

- **The IMF-3 is hosting multiple TEL-14 telephone interface modules.** An IMF-3 interface frame can only power eight TEL-14 interfaces on one PSU-101 power supply. If more TEL-14 interface modules are required, they must be installed in a second IMF-3 frame with a second power supply.

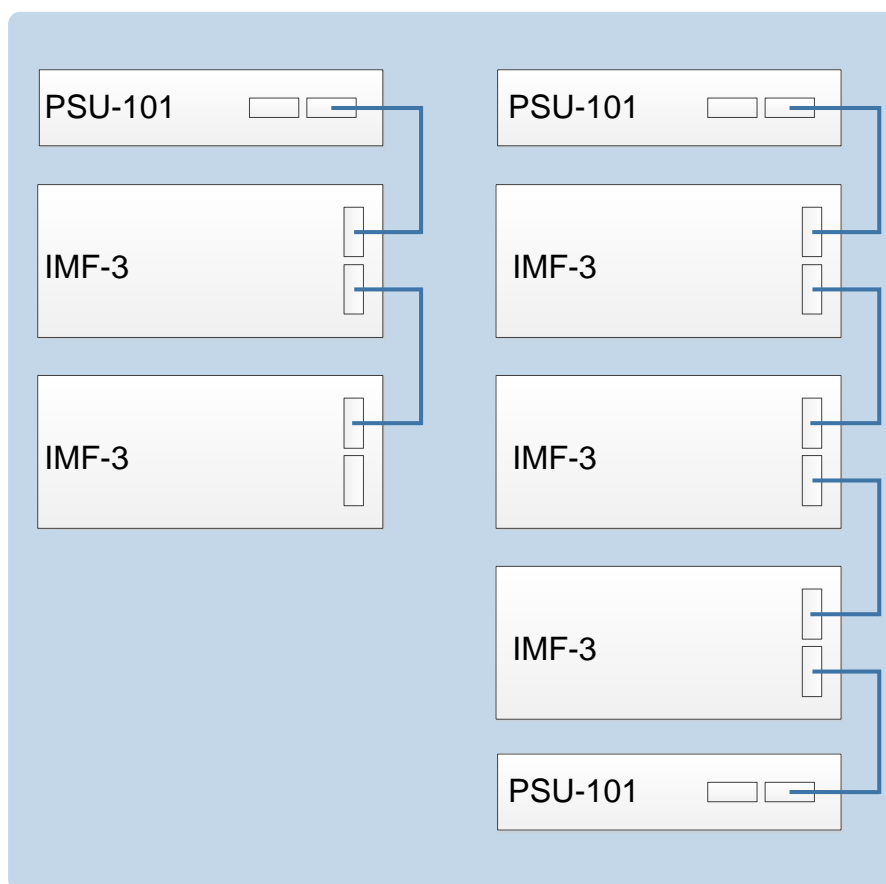

Figure 7: Example PSU-101 to IMF-3 connections

Installing **two** PSU-101 power supplies for each IMF-3 provides redundancy, because either of the two PSU-101 power supplies can power a complete system.

If one fails, it can be removed without interruption of the entire system. Rear panel connectors provide easy parallel connection to the IMF-3 interface frame.

A PSU-101 requires **90 - 260 VAC** at **45 - 65 Hz** with a maximum dissipation of **80W**.

5.3.1.1 PSU-101 alarm

An audible alarm is included in the **PSU-101**, and an additional set of alarm-relay contacts are provided on the supply.

Clear-Com recommends that these contacts be connected to the external alarm input of the matrices. If any of the power supplies in the PSU-101 fails, a system alarm is activated. LEDs on the front of the PSU-101s indicate the failure.

Note: For more information about the IMF-3, see the **IMF-3 manual**.

5.3.2 IMF-102

The IMF-102 has an internal power supply and a rear panel connector for connecting redundant power. The power supply is universal, operating over a voltage range of **90 - 250 VAC**. The maximum dissipation is **20W**.

Note: An additional power supply can be added for redundancy by connecting a PSU-101 power supply to the power connector on the rear panel.

For more information, see the: *IMF-102 Interface Module Instruction Manual*.

5.3.3 Current capacities and consumption

The current capacities of the power supplies are as follows:

+9 V analog	3.0 A
-9 V analog	3.0 A

The following chart provides the current drain of the +/- analog power supplies for interface modules and the IMF-3 interface frame.

Note: Some devices, such as interface modules, have a varying current depending on the operation of features. In Eclipse HX devices where it is possible to activate all operating features of all components used, use the maximum current column for planning.

Component	Average current	Maximum
IMF-3	0.20 A	0.20 A
CCI-22	0.00 A	0.00 A

FOR-22	0.07 A	0.15 A
TEL-14	0.28 A	0.37 A
RLY-6	0.10 A	0.15 A
GPI-6	0.02 A	0.02 A
AES-6	0.16 A	0.16 A

Table 6: Interface current consumption

6 *Wiring System Components*

This chapter describes how to connect an Eclipse HX matrix (Eclipse HX-Omega, Eclipse HX-Median, Eclipse HX-Delta or Eclipse HX-PiCo) to other system components, including:

- The EHX PC.
- User panels (V-Series and I-Series).
- Interface frames and interface modules.
- External alarms.
- Four-wire audio devices.
- Analog partyline systems (including Clear-Com Encore).

It also includes guidance on using GPIs / GPOs to trigger actions, and procedures for enabling E & M signaling.

Most user panels and interfaces connect to a matrix using **CAT5 single 4-pair shielded RJ-45 terminated cables**.

Note: For an overview of the entire installation process, see **3Installation Overview**.

For more information about component placement, specifications of individual products, and internal adjustments, see the specific documentation for that product. To configure user panels and interface modules, see your *EHX documentation*, including *EHX Help*.

6.1 **Using RJ-45 connectors**

The following section provides guidance on the use of RJ-45 connectors for connecting an Eclipse HX matrix) to other Eclipse HX system components.

All Eclipse HX devices have built-in RJ-45 connectors. Direct 4-pair cable with RJ-45 connectors on either end can connect an Eclipse matrix port to an individual panel. Shielded CAT5 cables are available with RJ-45 terminations already installed. Bulk RJ-45 connectors can be bought and installed on custom length cables.

6.1.1 Cabling standards

The term **category 5 (CAT5)** refers to a communications cable standard that calls out transmission characteristics of twisted-pair cables for data communication use. For each increasing **category (CAT)** number the guaranteed bandwidth for data communication purposes increases.

For the 4-pair wiring scheme between the matrix panels, Eclipse HX uses the **AT&T T568B** wiring standard for data cables. Cables for use with **Ethernet 10-BASE-T** are of this type. Cables are available in solid or stranded wire in either **#24** or **#26 AWG**.

There are at least five different wiring standards that use the RJ-45 connector. Although they look identical, many pre-made cables and utility items, like couplers, will not work properly with your Eclipse HX system. It is essential to know what wiring standard is used in any accessories.

Clear-Com recommends:

- The use of shielded CAT5 twisted cable with RJ-45 connectors on either end. However, there are various methods available to deliver these cables from one place to another.
- The use of shielded cables throughout the installation for EMC conformance. Unshielded cables can be used but in this case Clear-Com does **not** guarantee the crosstalk and noise figures.

Long runs with flat cable are **not** recommended. The data and audio pairs are **not** twisted which means that the crosstalk within the cable is high.

Cabling standard	Description
T568B	A mature, well supported standard. Advantages include: <ul style="list-style-type: none">• Fast easy termination of cables.• The availability of a vast array of wiring adapters and patching systems, permitting greater versatility when wiring Eclipse HX devices.• RJ-45 connectors can be connected to hardware quickly and easily.
T568A	T568A cables differ from T568B cables only in terms of the color of the insulation used on pairs 2 and 3. If you are not removing the ends from a pre-made cable, then this difference should not cause any issues. However, if the ends are removed from a pre-made cable (to shorten the cable or to punch the cable onto blocks), you should take account of the fact that the insulation colors for pairs 2 and 3 may differ.

Table 7: T568B and T568A cabling standards

Note: Test all cables thoroughly before connecting them.

6.1.2 Recommended cables, connectors and wiring tools

Ensure that the type of RJ-45 connector matches the wire type. Connectors are available for both stranded and solid wire. Clear-Com intercom panels do not require keyed connectors. See the following table for connector vendor and port numbers.

The following products are recommended as possible sources for cables, connectors and tools:

Product type	Recommended product(s)
Crimper	Siemon PT908 or AMP 2-231652-1 with 853400-1 dies
Stripper	Siemon CPT
Tester	Siemon STM-8
Connector RJ-45 Shielded 26-22 AWG Stranded or Solid RJ-45	Siemon PS-8-8
Cinch	CINCH FA-25PS/1-LF 25W D-type in-line 1000pF filter (UK supplier: Farnell 111-4108)
Ferrite core	Würth Elektronik part: 74271132

Table 8: Recommended cables, connectors and wiring tools

6.1.3 Installing RJ-45 Connectors

The following procedures are designed to help you install RJ-45 connectors correctly. Clear-Com recommends that the work is tested with a cable checker. When you are installing RJ-45 connectors, wires can slip out of the correct order as the prepared cable end is inserted into the connector.

The shorter, **general** procedure for avoiding this issue is as follows:

1. Strip enough jacket off the cable to be able to grasp the wires and pull the jacket back.
2. Untwist the wires and pull them into the correct order and let the jacket slip back to hold them in place.
3. If this is done correctly, the wires will stay in the correct order. Trim exposed wires to about 9/16 in. (14.28mm) and install into the connector.

The **detailed** procedure is as follows. To facilitate the installation of RJ-45 connectors:

1. Strip off enough of the outside vinyl jacket to be able to grip the wires inside easily (**2 in. or 50.8 mm**).

While holding the four twisted pairs in one hand, slide back the vinyl jacket and clamp it between your thumb and forefinger. Keep the jacket clamped in this retracted position until the fourth step.

2. Pull the twisted pairs to the one side and untwist them back to the edge of the vinyl jacket. Smooth the kinks out slightly by pulling the conductors through your fingers.
3. In the correct color sequence, pull one wire at a time, straight out, clamping it in place between your thumb and forefinger.

If a wire must cross the others, ensure that this occurs inside the jacket. Ensure that your color sequence matches the other side and it does not reverse.

Note: If you are rebutting a cable, verify the color code. The twisted pairs must be positioned correctly.

4. While holding the wires in the correct order, release your clamped thumb and forefinger enough to allow the retracted jacket to slip back.

You must still maintain enough pressure on your thumb and forefinger to hold the jacket and wires flat, but the individual wires should stay in the correct order without holding them with your other hand.

5. Cut the exposed wires to the correct length and slip them into the RJ-45 connector as you release your clamped thumb and forefinger.
6. Crimp and test the cable.

Note: Care must be exercised that the shield is not left pulled back inside the wire jacket. We also recommend that the drain wire is soldered to the side of a shielded style connector. Our tests show that a drain wire that is only crimped and not soldered will make an intermittent connection at best.

6.2 Connecting the matrix to a PC running EHX

The Eclipse configuration software (EHX) application is run on a PC.

6.2.1 Ethernet connection to the PC

The computer is normally connected to the matrix using:

- The **LAN1** connector (a **standard RJ-45 Ethernet connector**) on the rear of an Eclipse HX-Omega, Eclipse HX-Median or Eclipse HX-Delta matrix.

Note: **LAN1** is the default connector on the Eclipse HX-Omega, Eclipse HX-Median and Eclipse HX-Delta matrix. The **LAN2** connector (which is also a standard RJ-45 Ethernet connector) is **not configured** when it leaves the factory and must be enabled in EHX before it can be used.

- The **LAN** connector (a standard RJ-45 Ethernet connector) on the rear of the Eclipse HX-PiCo.

Ethernet connection allows single or multiple PCs to control, configure, monitor, and diagnose single or multiple matrices from anywhere on the WAN / LAN (see also **6.3 Connecting the matrix to an Ethernet network**).

For Eclipse HX-Omega, Eclipse HX-Median and Eclipse HX-PiCo, a ferrite core must be added to the socket end of each Ethernet cable to comply with European EMC standards. A suitable ferrite core is **Würth Elektronik part: 74271132**.

Shielded CAT5 cable is recommended for Electro Magnetic Compliance in EC countries.

6.2.2 Serial connection to the PC

You can also create a serial connection between the matrix and the EHX PC, using. :

- The **DB-9F** connector labeled **RS-232** on the rear of an **Eclipse HX-Omega, Eclipse HX-Median or Eclipse HX-Delta** matrix .
- The **3.5mm jack socket** labeled **RS-232** on the front of an **Eclipse HX-PiCo**.

Note: Shielded CAT5 cable should be used, where possible.

6.2.2.1 Eclipse HX-Median, Eclipse HX-Omega and Eclipse HX-Delta

To connect the EHX PC to the matrix, run cable from the matrix's R-232 DB-9M serial connector to the 9-pin serial port of the PC (see **Figure 6: PC serial DB-9F to matrix R-232 DB-9M connector**). The maximum recommended length of the cable is approximately **10 feet (3 meters)**.

Note: If the EHX computer does **not** have a serial port, and only offers USB, adaptors are generally available from computer parts suppliers.

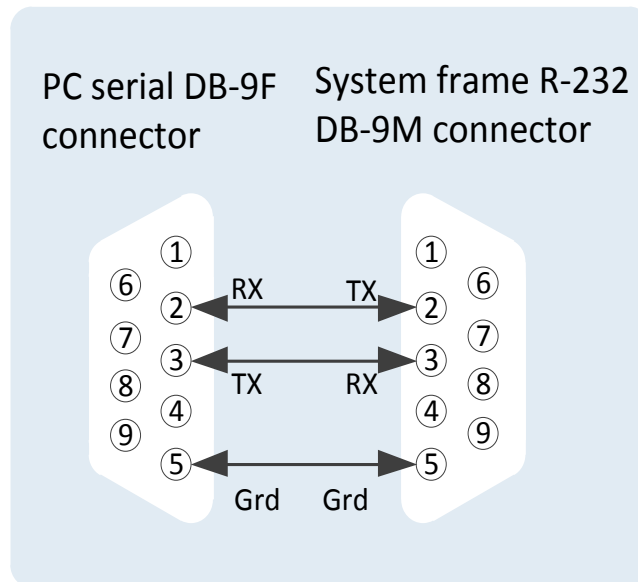

Figure 8: PC serial DB-9F to matrix R-232 DB-9M connector

6.2.2.2 Eclipse HX-PiCo

A **DB-9F** connector is used at the PC, when wiring for an Eclipse HX-PiCo serial connection. The **3.5mm jack socket** is labeled **RS-232** on the front of an Eclipse HX-PiCo. Ensure that:

- The data connections of **Pin 2 to jack plug tip** and **Pin 3 to jack plug ring** are followed.
- **Pin 5 (DB-9F)** goes through to the **jack plug screen**.

The cable will then be ready to use.

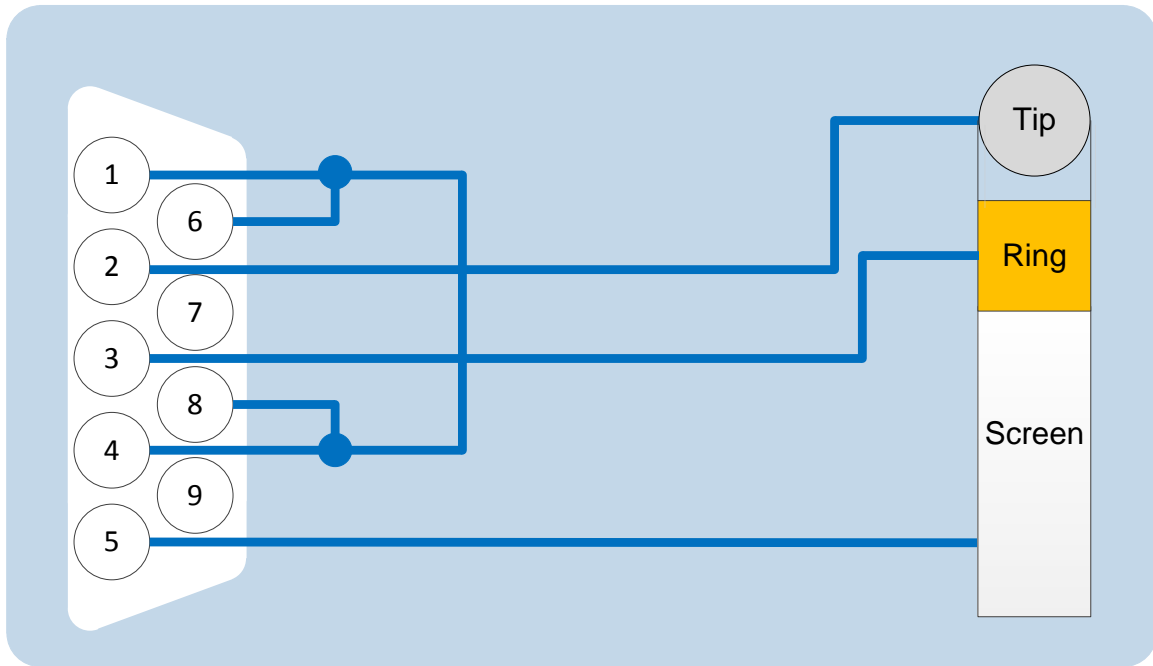

Figure 9: Pin connections for PC DB-9F to Eclipse HX-PiCo 3.5mm jack

PC Connection (DB-9F)	Eclipse HX-PiCo (3.5mm jack)
Pin 1	Links to Pins 4,6,8 on PC side
Pin 2	Tip
Pin 3	Ring
Pin 4	Links to 1, 6, 8 on PC side
Pin 5	Screen
Pin 6	Links to Pins 1, 4, 8 on PC side
Pin 7	N/C
Pin 8	Links to 1, 4, 6 on PC side
Pin 9	N/C

Table 9: Pin connections for PC DB-9F to Eclipse HX-PiCo 3.5mm jack

6.3 Connecting the matrix to an Ethernet network

To connect a matrix to an Ethernet network (WAN / LAN), use:

- The **LAN1** connector (a **standard RJ-45 Ethernet connector**) on the rear of an Eclipse HX-Omega, Eclipse HX-Median or Eclipse HX-Delta matrix.
Note: **LAN1** is the default connector on the Eclipse HX-Omega / Eclipse HX-Median / Eclipse HX-Delta matrix . The **LAN2** connector (which is also a standard RJ-45 Ethernet connector) is **not configured** when it leaves the factory and must be enabled in EHX before it can be used.
- The **LAN** connector (a standard RJ-45 Ethernet connector) on the rear of the Eclipse HX-PiCo.

For Eclipse HX-Omega, Eclipse HX-Median and Eclipse HX-PiCo, a ferrite core must be added to the socket end of each Ethernet cable to comply with European EMC standards. A suitable ferrite core is **Würth Elektronik part: 74271132**.

Shielded CAT5 cable is recommended for Electro Magnetic Compliance in EC countries.

See also **6.2.1 Ethernet connection to the PC**.

Pin	Function
Pin 1	Transmit data +
Pin 2	Transmit data -
Pin 3	Receive data +
Pin 4	N / C
Pin 5	N / C
Pin 6	Receive data -
Pin 7	N / C
Pin 8	N / C

Table 10: Pin assignments for LAN connectors

Note: Shielded CAT5 cable should be used, where possible.

6.4 Connecting the matrix to a PC running Production Maestro Pro

Production Maestro Pro is the is a multi-user, multi-matrix PC based software package which provides fast, intuitive audio routing control for Eclipse HX systems.

Note: For more information, see the product description on the Clear-Com website:

<http://www.clearcom.com/product/digital-matrix/software/production-maestro-pro>

6.4.1 LMC-64 interface card

Access to the audio level metering functionality of Production Maestro Pro is usually achieved using the **LMC-64 interface card**.

For more information about the LMC-64 interface card (which you can fit to either an Eclipse HX-Omega, Eclipse HX-Median or Eclipse HX-Delta matrix), see:

- The *LMC-64 manual*.
- The *Eclipse HX-Omega User Guide*.
- The *Eclipse HX-Median User Guide*.
- The *Eclipse HX-Delta User Guide*.

6.5 Connecting the matrix to user panels

The Eclipse HX system uses a 4-pair (analog) wiring scheme between the matrix and user panels (V-Series and I-Series panels). All supported panels have built-in RJ-45 connectors.

6.5.1 4-Pair analog wiring

4-pair analog wiring is performed with shielded CAT5 RJ-45 cable:

Pair	Description
Pair 1	Transmits analog audio from the matrix to the panel.
Pair 2	Transmits digital data from the panel back to the matrix.
Pair 3	Transmits audio from the panel to the matrix.

Pair 4

Transmits digital data from the matrix back to the panel.

Table 11: 4-Pair analog wiring

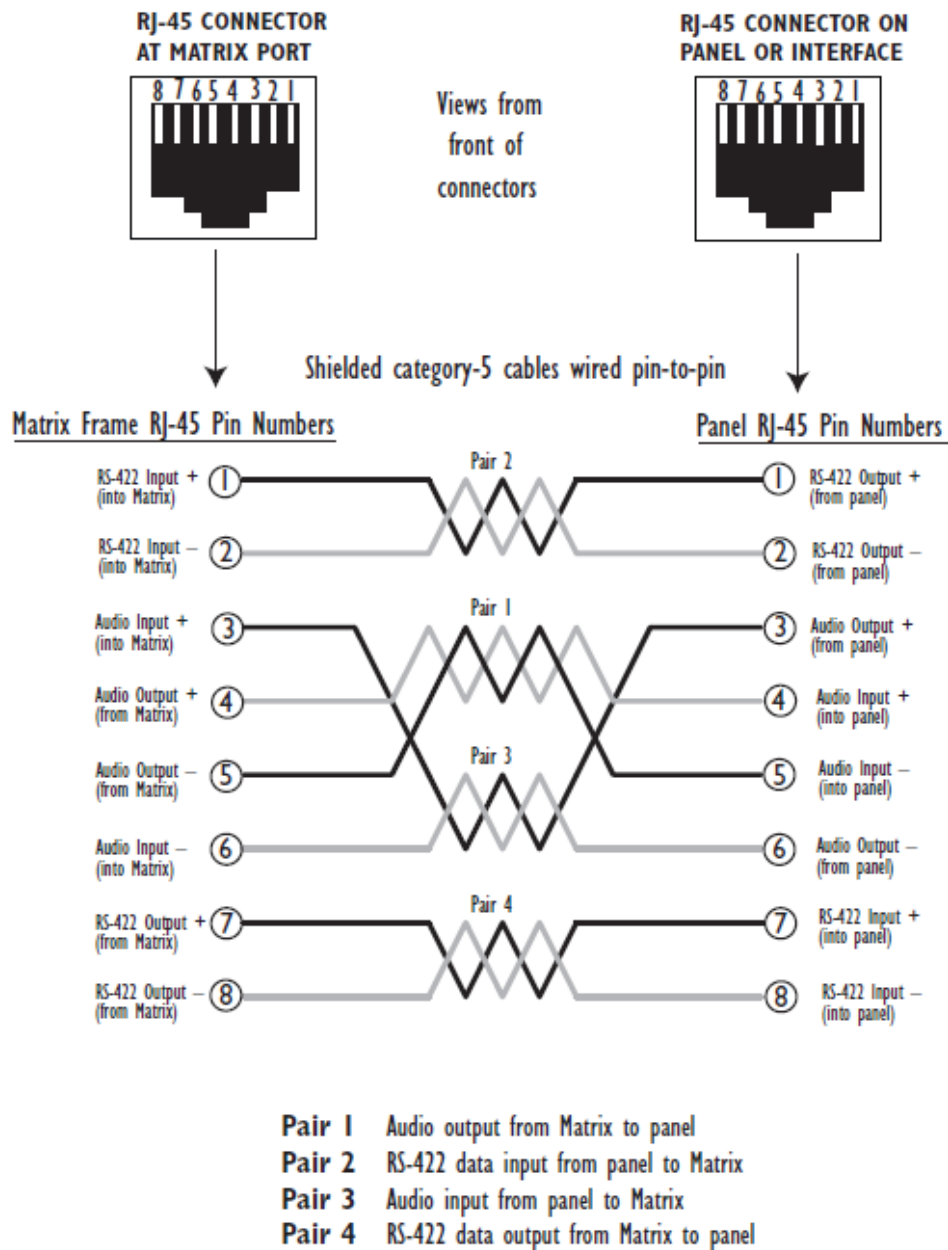

Figure 10: 4-Pair analog wiring, matrix to panel

6.6 General Purpose Outputs (GPOs)

A general purpose output (GPO) or relay is a switch that is controlled remotely. The relay is programmed in EHX to close a contact whenever a user panel's key is pressed. When the contact is closed, it completes an electronic circuit's signal path so that a remote device (such as a light) is powered.

A GPO can be programmed to mute a speaker, to turn on an applause light, open a door lock, or perform a variety of other functions.

The **male 25-pin D-type socket** labeled **GP OUT** on the rear of the matrix connects to eight general-purpose outputs (GPOs). The general purpose outputs are single-pole double-throw relays with contact ratings of **30 VDC (volts direct current) at 1 ampere**.

Shielded cable should be used to connect GPOs.

If the **GP-OUT** port is used on **either** an HX-Omega matrix fitted with **XP** power supplies (part 740101Z) or an Eclipse HX-Median matrix fitted with **HITRON** power supplies (740134Z) the following filter must be fitted between the **PROC-RCC** socket and the cable:

CINCH FA-25PS/1-LF 25W D-type in-line 1000pF filter
(UK supplier: Farnell 111-4108)

This is an EMC conformance requirement only.

If the Eclipse HX-Omega / Eclipse HX-Median matrix is equipped with Power-One power supplies (720379Z), this filter should not be fitted. If this filter is already fitted to the Eclipse HX-Omega or Eclipse HX-Median and the power supplies are changed to Power-One units, the filter must be removed before the matrix is powered up.

Each general-purpose output (GPO) has a relay inside the Eclipse HX-Omega, Eclipse HX-Median or Eclipse HX-Delta matrix. When a general-purpose output is:

- **Inactive**, the associated **common** pin on the **GP OUT** connector is shorted to the relevant **normally closed** pin.
- **Active**, the short between the **common** pin is broken and a new connection is made between the **common** pin and the **normally open** pin.

DB-25M Connector		
Pin	Description	Relay
Pin 1	Common	RELAY1
Pin 2	Normally closed	
Pin 3	Normally open	
Pin 4	Common	RELAY2
Pin 5	Normally closed	
Pin 6	Normally open	
Pin 7	Common	RELAY3
Pin 8	Normally closed	
Pin 9	Normally open	
Pin 10	Common	RELAY4
Pin 11	Normally closed	
Pin 12	Normally open	
Pin 13	Digital ground	-
Pin 14	Common	RELAY5
Pin 15	Normally closed	
Pin 16	Normally open	
Pin 17	Common	RELAY6
Pin 18	Normally closed	
Pin 19	Normally open	
Pin 20	Common	RELAY7
Pin 21	Normally closed	
Pin 22	Normally open	
Pin 23	Common	RELAY8

Pin 24	Normally closed	
Pin 25	Normally open	

Table 12: Pin configuration of the GPO connector (DB-25M)

Note: See also Figure 11: Pin configuration of the GPO connector (DB-25M) below.

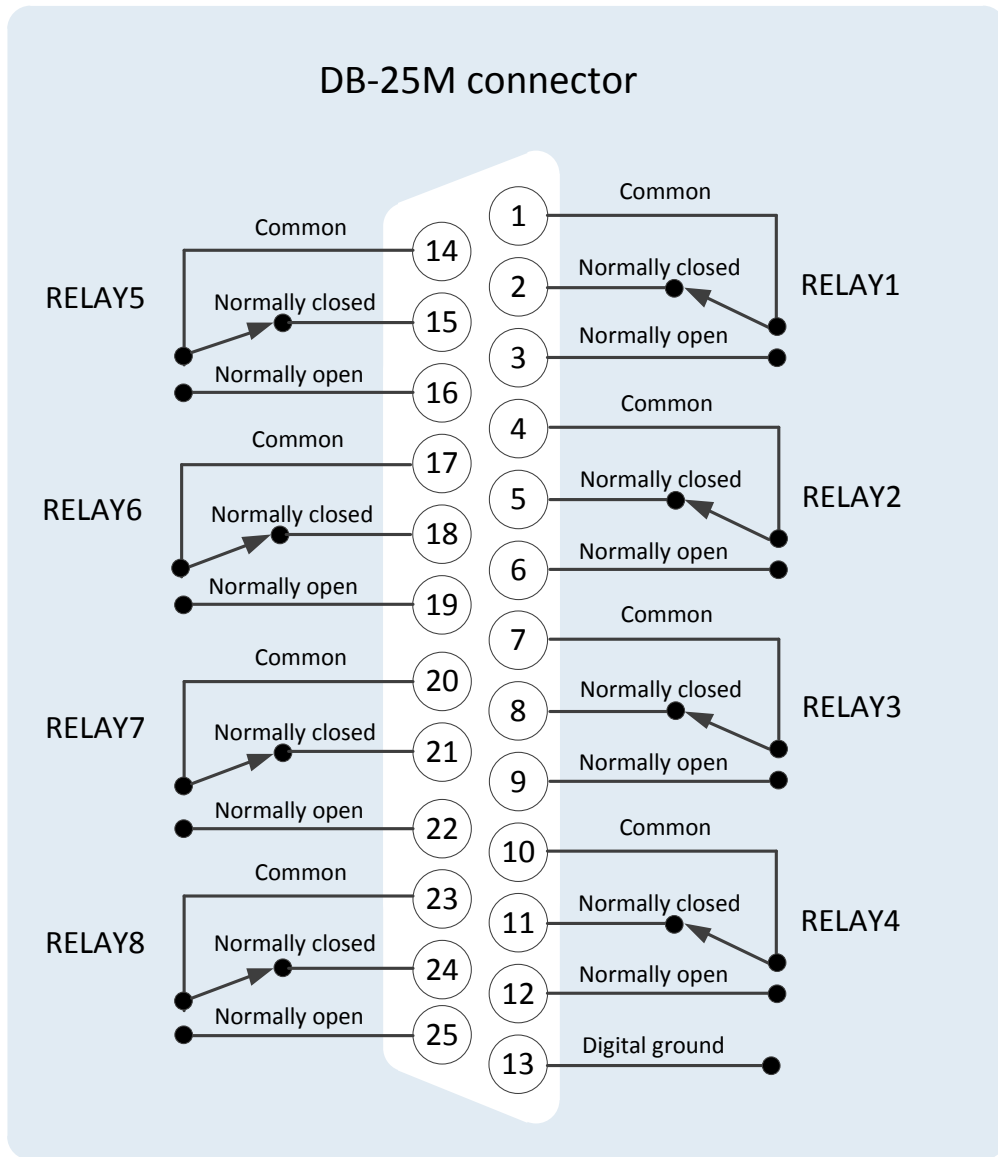

Figure 11: Pin configuration of the GPO connector (DB-25M)

Note: The general purpose outputs are single-pole double-throw relays with contact ratings of 30 VDC (volts direct current) at 1 ampere.

6.7 General Purpose Inputs (GPIs)

You can connect an external logic device (such as an external foot switch, a panel-mounted switch, or the logic output of some other device) to the connector labeled **GP IN** on the rear of the Eclipse HX matrix.

When the external logic device is activated, it sends a control signal into the matrix to perform one of several preset functions, such as turning an intercom panel's microphone on or off, muting a microphone's output, or turning a panel's speaker off. The function to perform and the panel upon which it is performed is configured using the Eclipse configuration software (EHX).

The DB-25 connector labeled **GP IN** on the rear of the Eclipse matrix connects to eight local general-purpose inputs. The GPIs are opto-isolated. Shielded cable should be used to connect GPIs.

DB-25F Connector	
Pin	Description
Pin 1	Logic input 1
Pin 2	Logic input 2
Pin 3	Logic input 3
Pin 4	Logic input 4
Pin 5	N / A
Pin 6	N / A
Pin 7	N / A
Pin 8	N / A
Pin 9	Ground
Pin 10	Ground
Pin 11	Ground
Pin 12	Ground
Pin 13	Ground
Pin 14	Logic input 5
Pin 15	Logic input 6
Pin 16	Logic input 7
Pin 17	Logic input 8

Pin 18	N / A
Pin 19	N / A
Pin 20	N / A
Pin 21	N / A
Pin 22	V IN +
Pin 23	V IN +
Pin 24	V IN -
Pin 25	V IN -

Table 13: Pin connection General Purpose Inputs, DB-25F connector

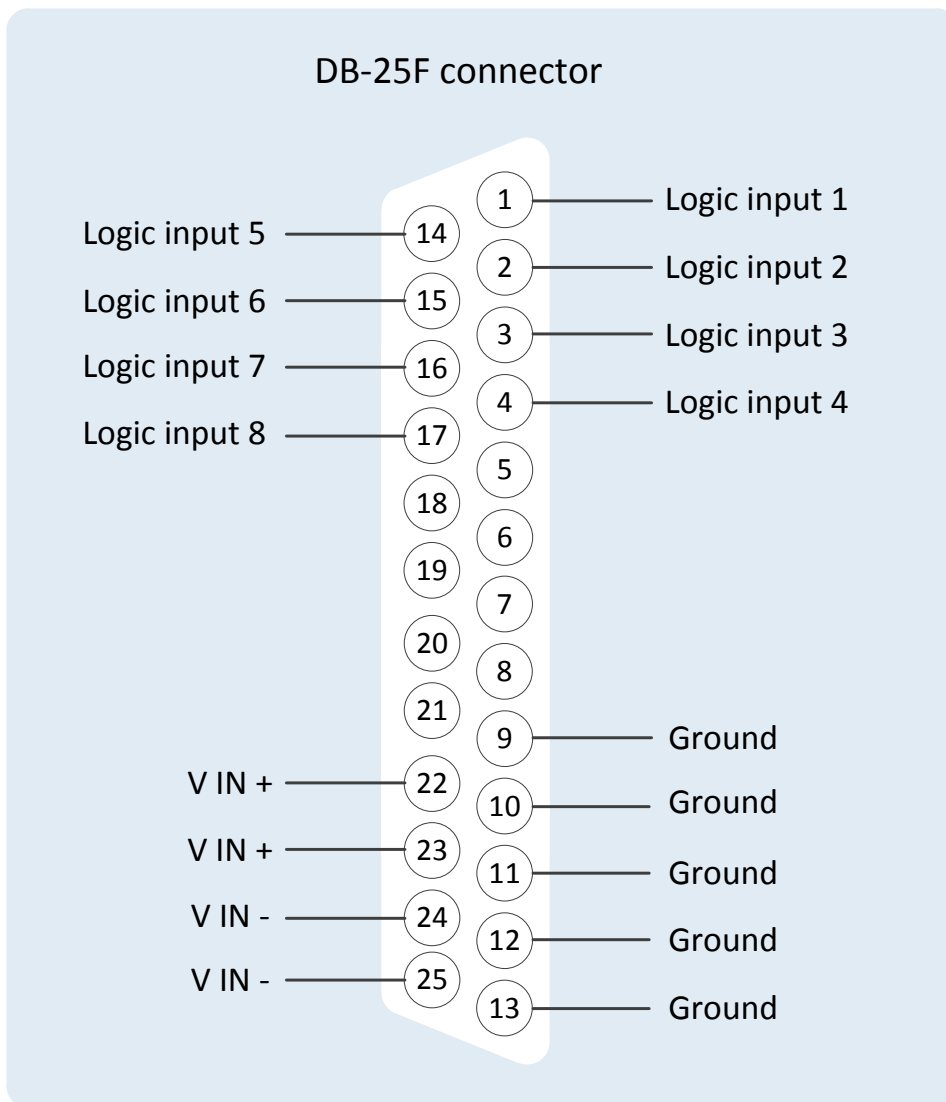

Figure 12: Pin connection General Purpose Inputs, DB-25F connector

6.7.1 Modes for General Purpose Inputs (GPIs)

General-purpose inputs (GPIs) operate in either of two modes:

- **Opto-isolated mode**, which requires the externally connected equipment to provide the current to power the general-purpose input.
- **Non-isolated mode**, which means that the externally connected equipment is **not required** to power the general-purpose input. A voltage output on the **GP IN** connector supplies the current.

To select a mode, move the J1 jumper on the CPU rear card to one of two positions (The J1 jumper is located on the inner-frame side of the DB-25 connector):

1. For **Opto-isolated mode**, fit the J1 jumper across pins 1 and 2.
2. For **Non-isolated mode**, fit the J1 jumper across pins 2 and 3 (This is the default mode, when the matrix leaves the factory).

6.7.1.1 Opto-isolated mode

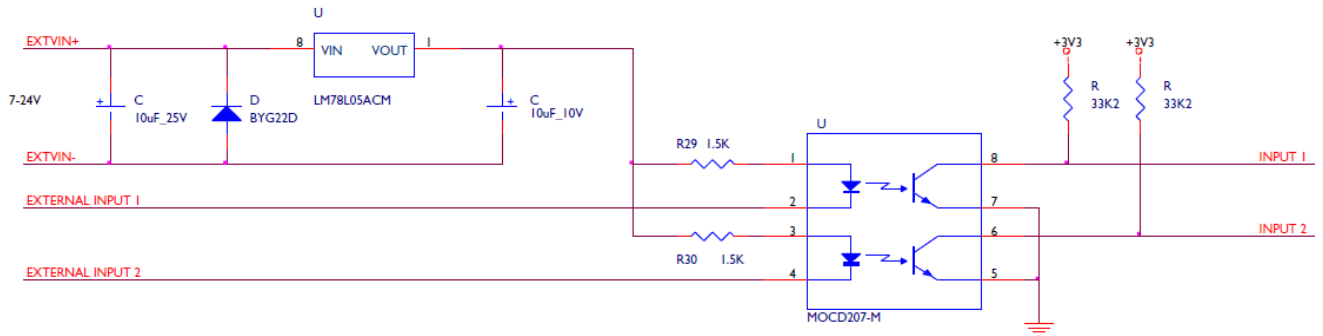

Figure 13: Opto-isolated connection to Eclipse GPI connector

In this mode, a DC voltage of between 7 and 24 volts is required at the **EXTVIN+** pin with relation to the **EXTVIN-** pin. To cause an input to detect an active signal, current must flow from the relevant input pin.

The external device should draw no current to cause an inactive input and at least **5 mA** to cause an active input. The opto-isolator drive line contains a **1.5 kOhm** resistor to limit the current through the opto-isolator. Therefore the input pins can be connected directly to the **EXTVIN-** level to cause an active input.

The voltage level at the external input pin should not be allowed to go below **EXTVIN-** or above **+6 V** with respect to **EXTVIN-**.

Note: The **Logic 1** input (external input 1) must be shorted to ground to render the **Logic 1** signal active.

6.7.1.2 Non-isolated mode

Note: The non-isolated mode is the default mode, when the matrix leaves the factory.

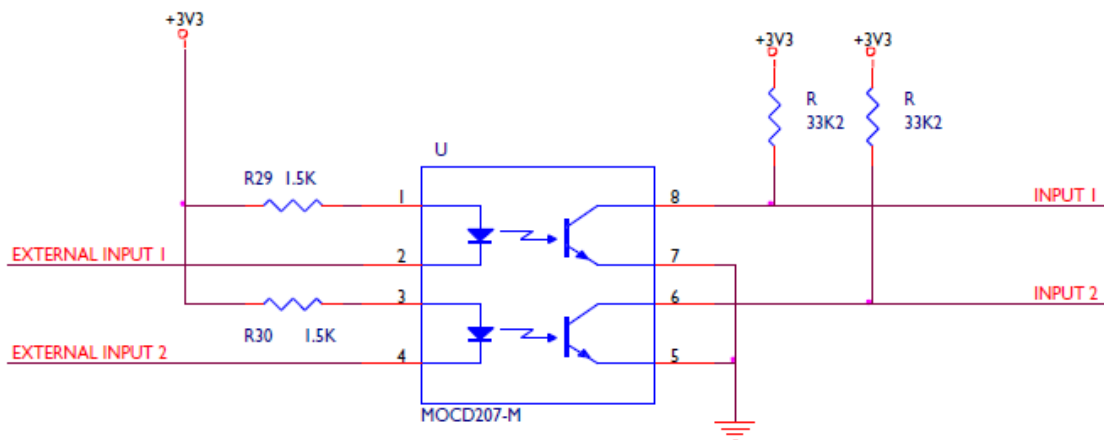

Figure 14: Non-isolated connection to Eclipse GPI connector

To cause an input to detect an active signal, current must flow from the relevant input pin.

The external device should draw no current to cause an inactive input and at least **5 mA** to cause an active input. The opto-isolator drive line contains a **1.5 kOhm** resistor to limit the current through the opto-isolator. Therefore the input pins can be connected directly to a ground pin to cause an active input.

The voltage level at the external input pin should **not** be allowed to go below ground or above **+6** with respect to ground.

Note: The **Logic 1** input (external input 1) must be shorted to ground to render the **Logic 1** signal active.

6.8 E & M signalling with an E-QUE E1 / T1 interface card

When you enable E & M signaling on an E1 / T1 direct E-QUE card, you associate a GPI and a GPO in EHX with each configured port.

You can use the:

- GPI (General Purpose Input) to trigger an action / control on an **incoming signalization**.
- GPO (General Purpose Output) to trigger an **outgoing signalization** from a control.

6.8.1 Example: Ship-to-shore satellite system

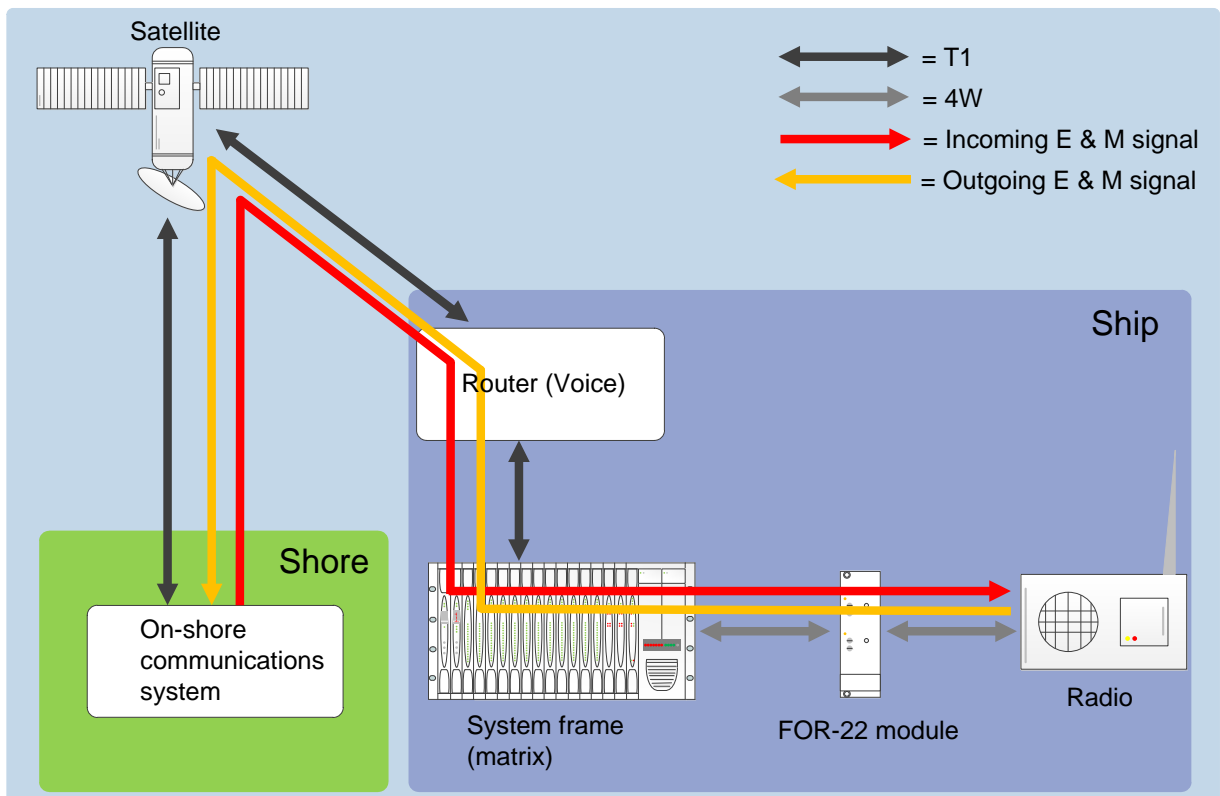





Figure 15: Ship-to-Shore E & M signaling

In **Figure 15: Ship-to-Shore E & M signaling**, E & M signaling is carried with audio channels on the direct T1 connection and then split into logic functions in the matrix:

1. The **direct E1 / T1 connection** () carries audio and E & M signaling (the **incoming E & M signal** ()) from the on-shore communications system.
2. The E & M signal is received by the E-QUE card in the matrix, and treated as a **GPI** by the matrix.
3. The **GPI** generates the audio routes (where applicable) and indication outputs required by the **FOR-22 interface module** to generate relay closure for **radio PTT (Push-to-Transmit)**.
4. The **FOR-22** transmits incoming audio from the ship radio to the matrix.
5. The incoming audio is VOX detected in the matrix's MVX-A16 analog card.

The MVX-A16 card is configured in EHX to generate the required audio routes (where applicable) and drive E signaling, as represented by a **GPO** on the appropriate T1 channel of the E-QUE card.

6. The **direct E1 / T1 connection** carries audio and E & M signaling (the **outgoing E & M signal** ()) to the on-shore communications system.

Tip: For more information about direct E-QUE E1 / T1 connections, see **7.4 E1 / T1 linking**.

6.8.2 Enabling E & M signaling on the E-QUE card

To enable E & M signaling on an E1 / T1 direct E-QUE card:

1. In EHX, select the appropriate matrix. Go to **Hardware > Cards and Ports**.
2. From the **Card Slot** drop-down menu, select an available card slot.

From the **Card Type** drop-down menu, select **either** of the following card types (in accordance with your requirements):

E-QUE (T1 Direct)

E-QUE (E1 Direct)

3. The ports are displayed for the selected card type. Configure as many ports as you require as **T1 / E1 Direct**.

Note: A T1 direct E-QUE card has 48 ports. An E1 direct E-QUE card has 60 ports.

4. Click **Card Properties** (to the right of the ports screen).
5. In **Card Properties > Clock Recovery**, ensure that **Line recovery** is selected.
6. In **Card Properties > Codec**, select the appropriate **Top Half** and **Bottom Half Codec**.

Note: **Top Half** (T1 direct = ports 1 – 24 / E1 direct = ports 1 – 30) and **Bottom Half** (T1 direct = ports 25 – 48 / E1 direct = ports 31– 60) correspond to the two physical T1 / E1 connections with the E-QUE card.

Recommendation: For **T1 direct E-QUE cards**, Clear-Com recommends that you select the **G711 µ-law** codec for optimum audio quality.



Figure 16: Card Properties > Codec

7. In **Card Properties > E & M Signaling**, select **Enable E & M Signaling** [].

Click **OK**.





8. To view the ports associated with GPIs, open the **Matrix and Modular GPIs** screen by clicking the tab at the bottom of the ports screen.

6.8.3 Using the GPIs / GPOs to trigger actions

After enabling E & M signaling on the E1 / T1 E-QUE cards, you can use the GPIs / GPOs associated with the configured ports to trigger actions.

For example, in **6.8.1 Example: Ship-to-shore satellite system**:

1. The E & M signal from the shore-based communications system () is forwarded by the matrix to the FOR-22 interface module. The FOR-22 module then generates relay closure for **radio PTT (Push-to-Transmit)**.
2. An E & M signal is returned to the matrix () to indicate that audio from the radio is being received.

To send E & M signals from the matrix to a ship's radio, and to receive E & M signals in the matrix from the activated radio:

1. In EHX, select the appropriate matrix. Go to **Configuration > Routes**.
2. In **Configuration > Routes**, add two new routes:
 - a. Create a route from the first configured port on the E & M enabled E1 / T1 direct E-QUE card to the first available port on the FOR-22 interface module.

Label the route (for the purposes of this example) **Radio Out**.
 - b. Create a route from the first available port on the FOR-22 interface module to the first configured port on the E & M enabled E1 / T1 direct E-QUE card.

Label the route (for the purposes of this example) **Radio In**.
3. In **Configuration > Controls**, add two new controls:
 - a. Label the first control **PTT1**.
 - b. Add the **Radio Out** route to **PTT1**.
 - c. Add the FOR-22 interface module relay / GPO (a relay associated with the FOR-22 port in the Radio Out route) to **PTT1**.

Note: This relay is used to trigger PTT at the ship's radio.

- d. Label the second control **REC1**.
- e. Add the **Radio In** route to **REC1**.
- f. Add the **E & M relay / GPO** (the relay associated with the first configured port on the E1 / T1 direct E-QUE card) to **REC1**.

Note: This relay receives the E & M signal from the ship's radio into the matrix.

4. In **Configuration > Cards and Ports > Matrix and Module GPIs:**

- a. Select the appropriate **E & M enabled GPI** (the GPI associated with the first configured port on the E1 / T1 direct E-QUE card).
- b. In **Advanced Settings**, enable / select the trigger for the **PTT1** control.

Note: When the E & M signal is received from the shore-based communications system at the E1 / T1 direct E-QUE card, the E & M signal is sent to the FOR-22 / radio.

5. In **Configuration > System Ports:**

- a. Select the port for the FOR-22 interface module.
- b. In **Advanced Settings > VOX action**, select the **REC1** control from the drop-down menu.
- c. In **Advanced Settings > VOX action > Voice Op. Switch**, adjust the *Audio Off Delay* and *Audio Detect Threshold* as required.

Note: When VOX is detected, the E & M signal for the FOR-22 / radio is sent via the E1 / T1 direct E-QUE card to the shore-based communications system.

6.9 Connecting the matrix to an external alarm

You can connect the Eclipse HX-Omega / Eclipse HX-Median / Eclipse HX-Delta matrix to an external alarm device using the **Alarm I/O DB-9F connector**.

Pins are also available for connecting an external alarm source to the matrices internal Alarm System.

Note: For details on the functions that are monitored by the Alarm System, see the **Eclipse HX-Omega, Eclipse HX-Median or Eclipse HX-Delta User Guides**.

When an external alarm is connected to the matrix, a system failure will activate the relay contacts connected to **pins 4, 5, and 9** of the **Alarm I/O DB-9F connector**.

Note: The relay contacts connected to **pins 4, 5 and 9** are 'dry', and are rated at **1 A at 24 VDC**. They are **not** recommended for AC mains line current.

Pins are provided for adding an additional alarm source to the matrix's alarm system. **Pin 6** is an alarm input to the matrix. The pin is connected to the input of a **3.3V** logic device. A logic high on this input will cause an alarm condition in the matrix.

Pin 1 is a voltage source out of the matrix. It is connected through a 10k ohm pull-up resistor to the +5 volt supply rail inside the matrix. A contact closure placed across **pins 1 and 6** will also cause an alarm condition.

6.9.1 Connecting to the alarm outputs of the PSU-101 power supply

The alarm outputs of the PSU-101 could be wired directly to the pins of the **Alarm I/O DB-9F connector** described above, permitting the CPU card to report PSU failures also. Shielded cable should be used.

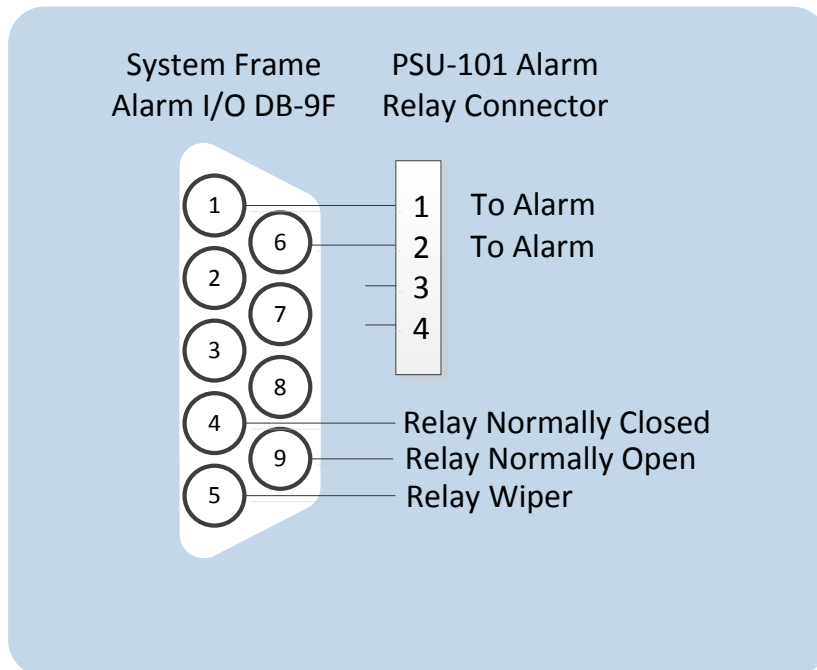

Figure 17: Alarm I/O connector

6.10 Connecting to a four-wire audio device

An external four-wire audio device can be directly connected to a port connector through the four audio pins. If there is excessive noise on the lines between the device and the matrix, the device may be electronically unbalanced with the rest of the system. The device must be isolated with external isolation transformers.

The **CALL SEND** output can be connected to the **CALL REC** input to tell the system software that this is a directly connected port.

EHX allows the changing of the audio output reference level between **-24, -21, -18, -15, -12, -9, -6, -3, 0, +3, +6, +9, +12** and **+14 dB**.

With a **+12dB** output reference level, it is possible to drive a **200 to 400 Ohm** headset directly with a port output for such uses as direct IFB feed.

The EHX configuration software allows the changing of the audio input reference level between **-12, -9, -6, -3, 0, +3, +6, +9, +11 dB**.

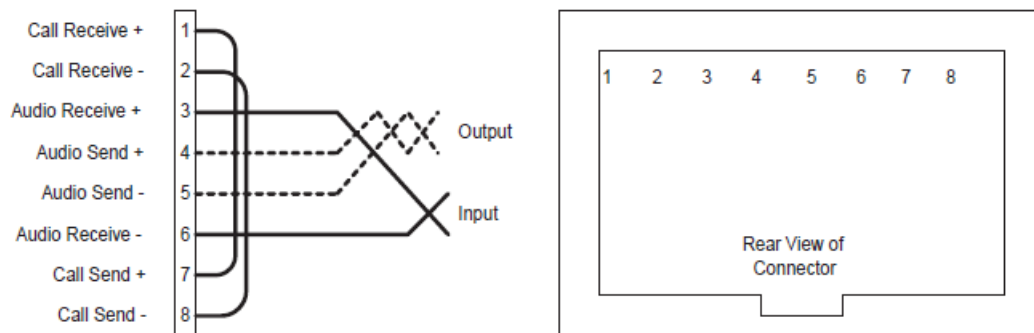

Figure 18: Direct matrix port connection

Shielded cable should be used.

6.11 Connecting to interface modules

Interface modules convert the four-wire signals of a central matrix port to some other form of communication (such as telephones, camera intercoms, two-way radios, and so on). In this way, non-four-wire devices can communicate with the central matrix.

Each interface module has hardware connectors to connect to **both** the central matrix and to the external device that communicates with the central matrix.

The Eclipse HX-Median has slots for 8 interface modules, in addition to 7 circuit cards (interface cards).

The Eclipse HX-Delta has slots for 3 interface modules, in addition to 4 circuit cards (interface cards).

Clear-Com also offers two types of interface frames, to house interface modules, the IMF-3, and the IMF-102 interface frames. For more information, see **4.2 Locating interface frame(s) and power supplies**.

The following figure shows the pin assignments of RJ-45 connectors when used to connect to interface frames (such as an IMF-3 frame):

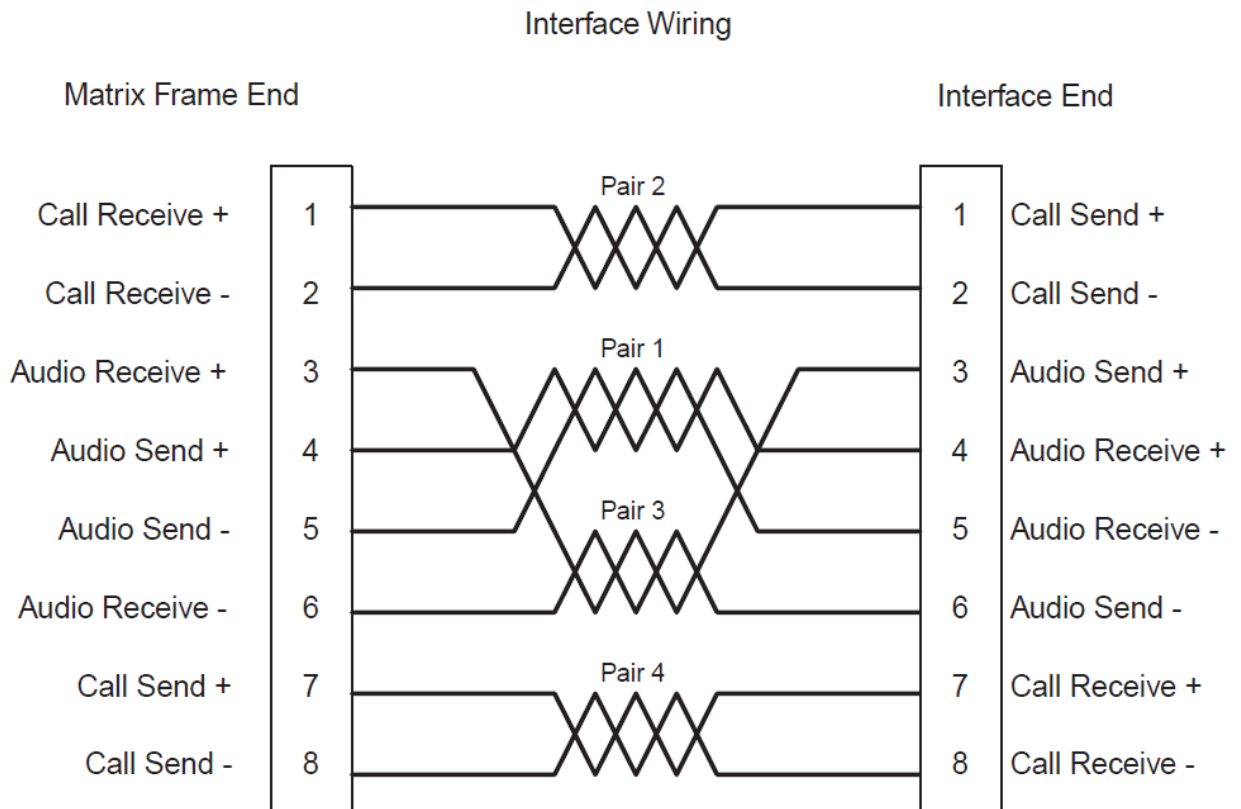

Figure 19: Matrix to IMF-3 interface frame connection

For Eclipse HX-Omega, Eclipse HX-Median and Eclipse HX-Pico, if the GPI/RLY port is used a ferrite core must be added to the socket end of the cable. A suitable ferrite core is Würth Elektronik part: 74271132.

Note: Shielded cable should be used, where possible.

6.11.1 Wiring schemes for the FOR-22 interface module

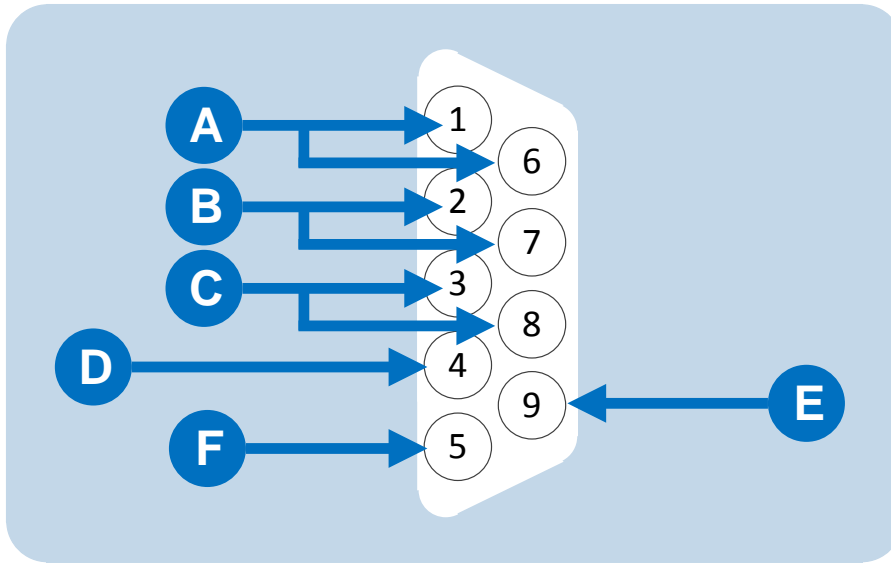

Figure 20: Pinout of DB-9M I/O connector for FOR-22s

Key to Figure 20: Pinout of DB-9M I/O connector for FOR-22	
Connector	Description
A	Pin 1 and Pin 6 = Audio output
B	Pin 2 and Pin 7 = Audio input
C	Pin 3 and Pin 8 = Logic input (+ / - 4 to 50V)
D	Pin 4 = Relay normally closed
E	Pin 9 = Relay wiper
F	Pin 5 = Relay normally open

Table 14: Pinout of DB-9M I/O connector for FOR-22

The FOR-22 four-wire/radio interface connects two external four-wire circuits to the matrix. Camera intercoms, two-way radios, microwave and satellite links, IFBs, and program audio in and out are candidates for use with the FOR-22.

A FOR-22 interface connects to an Eclipse HX matrix through the two RJ-45 connectors on its rear panel.

The **top** RJ-45 is for the **first channel** of the interface module. The **lower** RJ-45 is for the **second channel**.

The user side of the FOR-22 for each channel appears on a DB-9M connector on the rear of the IMF-3 or IMF-102 frame. Each channel is **identical**. The following sections describe how to wire for the various types of inputs and outputs available on the DB-9M connector:

- External audio devices.
- Call signal input.
- Relay contacts.

Note: Shielded CAT5 cable should be used, where possible.

6.11.1.1 External audio devices

Connect external audio devices to the FOR-22 ports through the two DB-9M connectors labeled “I/O” on the rear panel. Both the audio input and the audio output are transformer isolated.

Note: For more information on the various level ranges available on the input and output, see the **FOR-22 manual**.

6.11.1.2 Call Signal Input

The Call Signal input is used to receive a call/logic input signal from an external device and send it to the matrix. The voltage across the pins required to receive a call signal ranges from **4 - 50V**; + / - AC. The input will draw between **4** and **8 mA**.

6.11.1.3 Relay Contacts

Each FOR-22 interface channel features a relay that is associated with the logical call signal output of a port. A relay’s function depends on the function assigned to the FOR-22 port through the EHX configuration software. A relay can be assigned to operate with any label in the system: when that label is activated (either by a talk, listen, or both, as set from the configuration program), the relay will activate.

Note: For more information about configuring a relay, see **EHX Help**.

The relay can be used to activate an external device, such as an applause light in a studio, a cue light, or a security-door lock. The relays feature both **normally open** and **normally closed** contacts. The contacts are rated at **1 A** at **24 VDC**; they are **not** designed for switching mains AC line voltage.

6.11.2 Wiring schemes for the CCI-22 interface module

The CCI-22 interface module connects two 2-wire full-duplex partyline circuits to the matrix .

In the same way as the FOR-22, the CCI-22 dual audio interface module uses both the RJ-45 connectors on its rear panel for connection to the matrix (See also **6.11.1 Wiring schemes for the FOR-22 interface module**).

The **top** RJ-45 is for the **first channel** of the interface. The **lower** RJ-45 is for the **second channel**. The DB-9Ms are the interface module's audio and control inputs and outputs.

Note: For more information about the CCI-22 interface, see the **CCI-22 manual**.

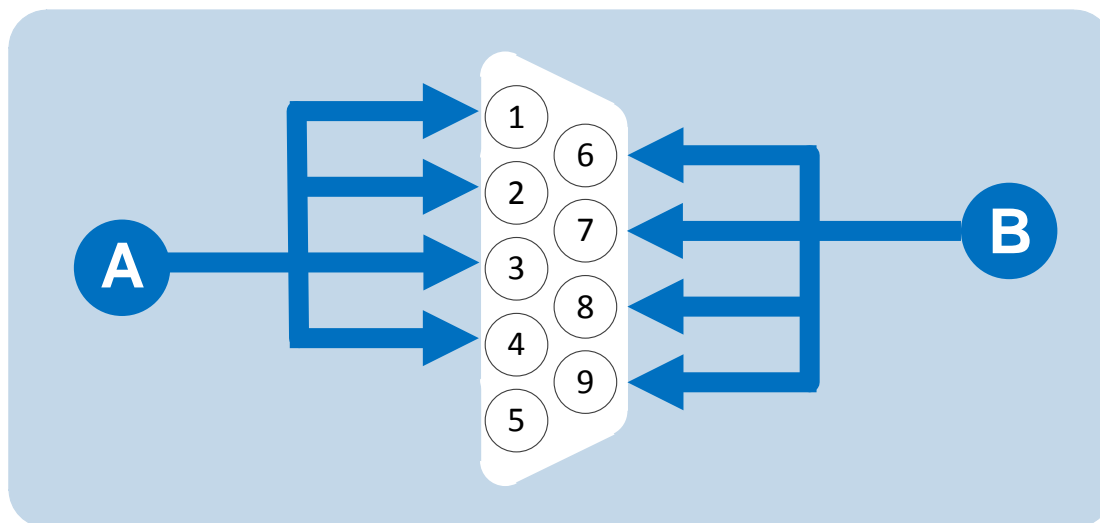

Figure 21: DB-9M interface I / O connector for CCI-22

Key to Figure 21: DB-9M interface I/O connector for CCI-22	
Connector	Description
A	<p>Channel #1:</p> <p>Pin 1 = Clear-Com / RTS</p> <p>Pin 2 = Ground</p> <p>Pin 3 = +30 VDC Power</p> <p>Pin 4 = Audio</p>
B	<p>Channel #2:</p> <p>Pin 6 = Clear-Com / RTS</p> <p>Pin 7 = Ground</p> <p>Pin 8 = + 30 VDC Power</p> <p>Pin 9 = Audio</p>

Table 15: Key to Figure 21: DB-9M interface I/O connector for CCI-22

The two DB-9M connectors are paralleled such that both partyline channels are available on each connector. It is possible to:

- Wire one DB-9 connector as **Channel #1** and the second DB-9 as **Channel #2**.

- Bring both channels out either DB connector together to create a **TW-type partyline** connection.

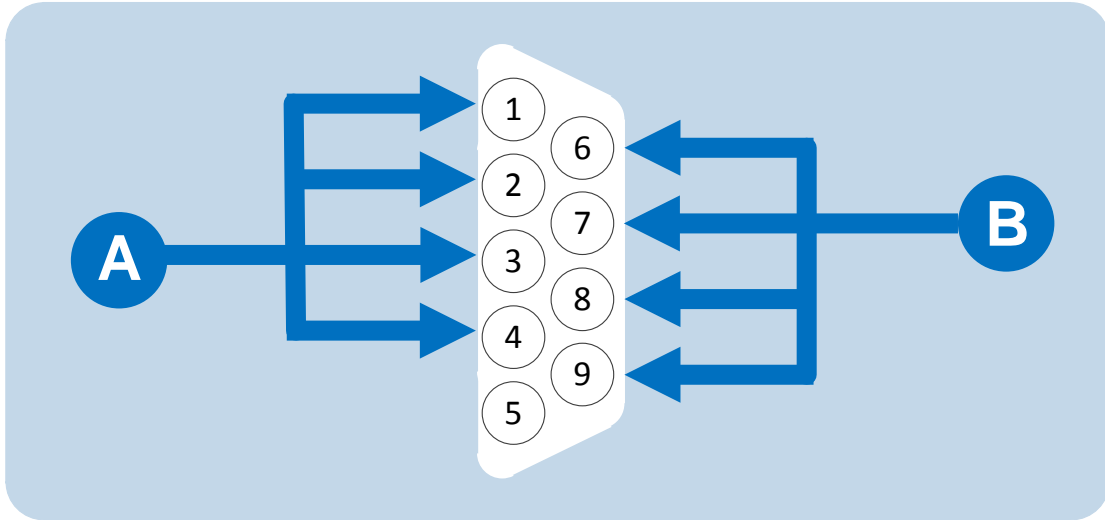

Figure 21: DB-9M interface I / O connector for CCI-22

Key to Figure 21: DB-9M interface I/O connector for CCI-22	
Connector	Description
A	<p>Channel #1:</p> <p>Pin 1 = Clear-Com / RTS</p> <p>Pin 2 = Ground</p> <p>Pin 3 = +30 VDC Power</p> <p>Pin 4 = Audio</p>
B	<p>Channel #2:</p> <p>Pin 6 = Clear-Com / RTS</p> <p>Pin 7 = Ground</p> <p>Pin 8 = + 30 VDC Power</p> <p>Pin 9 = Audio</p>

Table 15: Key to Figure 21: DB-9M interface I/O connector for CCI-22

Stations on Clear-Com analog partyline systems (such as Encore) connect to each other with two-conductor shielded microphone cable.

One conductor carries the DC power (**28 to 30 V**) for that channel, while the other conductor carries the duplex two-way intercom audio signal plus DC **Call Light** signaling for that channel. The shield acts as common ground for both power and signal for the channel.

6.11.2.1 Powering the CCI-22 interface module

Power to the CCI-22 interface module channels is provided by the external partyline.

The power connection for each channel is the **+30 VDC Power** pin on the appropriate DB-9M interface I/O connector on the rear-panel assembly. The CCI-22 channel is essentially just another beltpack on the partyline.

The power pin has DC filtering circuitry that provides a high impedance for the audio such that power can be received from **a powered line or TW line**, as is common with RTS systems. For TW operation tie the **AUDIO** and **POWER** pins together.

6.11.2.2 Terminating the partyline channels

Each partyline channel requires exactly one termination circuit. The termination circuit is usually built into the system component that provides the party line's power. Connecting more than one termination circuit to a party line will impair the sidetone null and degrade the line's audio quality.

Important note:

When a CCI-22 partyline channel is connected to a Clear-Com partyline, the Clear-Com/RTS Select pin must be left floating.

Grounding this pin selects the RTS mode, which is incompatible with Clear-Com partylines.

6.11.3 Wiring schemes for TEL-14 interface modules

The TEL-14 telephone interface module connects two telephone lines to the matrix. The interface can be used to:

- Establish IFB connections between the main intercom and remote production trucks.
- Link intercom communication between remote systems.
- Enable telephone calls directly to or from any intercom panel in an Eclipse system.

The TEL-14 uses each of the RJ-45 connectors on its rear panel for connection to a matrix port. One RJ-45 is for **Line A** of the interface and the other RJ-45 is for **Line B** of the interface.

The DB-9M connectors are the **Line A** and **Line B** connections to the telephone line. Clear-Com provides DB-9F to RJ-11 adapters so that standard phone line RJ-11 plugs and jacks can connect directly to the interface.

Note: For more information about the TEL-14 interface module, see the **TEL-14 manual**.

6.11.3.1 Wiring the TEL-14 interface to an IMF-3 interface frame

On the rear of the IMF-3 frame, there is a separate rear-panel assembly for each interface module, which contains four connectors for each interface.

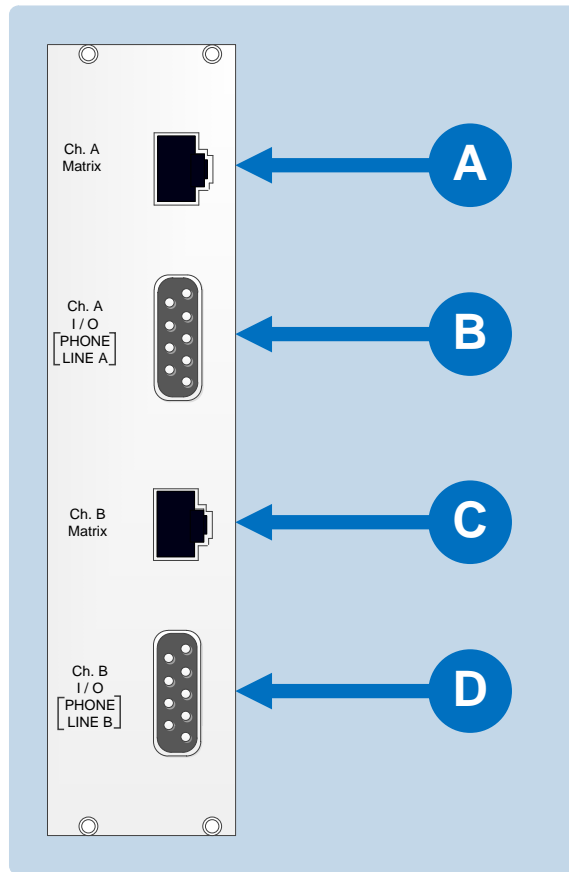

Figure 22: Wiring an IMF-3 rear panel to a TEL-14 interface module

Key to Figure 22: Wiring an IMF-3 rear panel to a TEL-14 interface module	
Connector	Instruction / description
A	The upper DB-9M connector is used to connect to the first telephone line, line A .
B	The upper RJ-45 connector is then used to connect telephone line A to the matrix.
C	The lower DB-9M connector is used to connect to the second telephone line, line B .
D	The lower RJ-45 connector is used to connect telephone line B to the matrix.

Table 16: Key to Figure 22; Wiring an IMF-3 rear panel to a TEL-14 interface module

Note: To allow use of a common RJ-11 terminated telephone line, Clear-Com provides **two DB-9F to RJ-11 adapters (Clear-Com part 770025)**.

For internal dip-switch settings and adjustments, see the **TEL-14 manual**.

6.11.3.2 Wiring a TEL-14 interface to an IMF-102 interface frame

On the rear of the IMF-102, there are two sets of four connectors each, arranged horizontally.

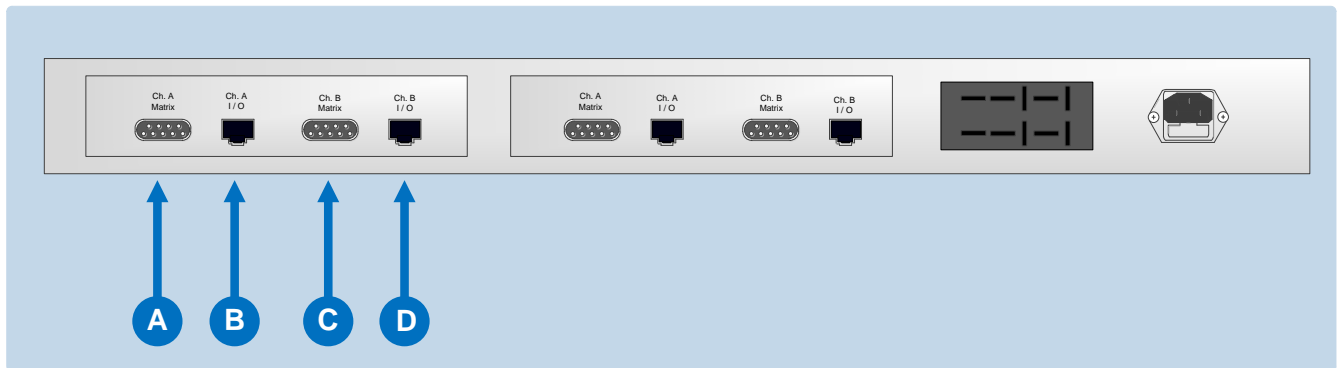

Figure 23: Wiring an IMF-102 rear panel assembly to a TEL-14 interface





Key to Figure 23: Wiring an IMF-102 rear panel to a TEL-14 interface module	
Connector	Instruction / description
	DB-9M connector. Connects to the first telephone line, line A .
	RJ-45 connector. Connects telephone line A to the matrix.
	DB-9M connector. Connects to the second telephone line, line B .
	RJ-45 connector. Connects telephone line B to the matrix.

Table 17: Key to Figure 23: Wiring an IMF-102 rear panel to a TEL-14 interface module

Note: To allow use of a common RJ-11 terminated telephone line, Clear-Com provides two **DB-9F to RJ-11 adapters (Clear-Com part 770025)**.

For internal dip-switch settings and adjustments, see the **TEL-14 manual**.

6.11.3.3 Connecting a TEL-14 interface to the telephone line

Connecting the telephone line can be accomplished with one of two methods:

- Use the **RJ-11 to DB-9F adapters** supplied by Clear-Com with the TEL-14 interface module.
- Directly wire each telephone line to a DB-9F connector using the pinouts as shown in the following figure (which displays the wiring diagram of the **RJ-11 to DB-9F adapter**).

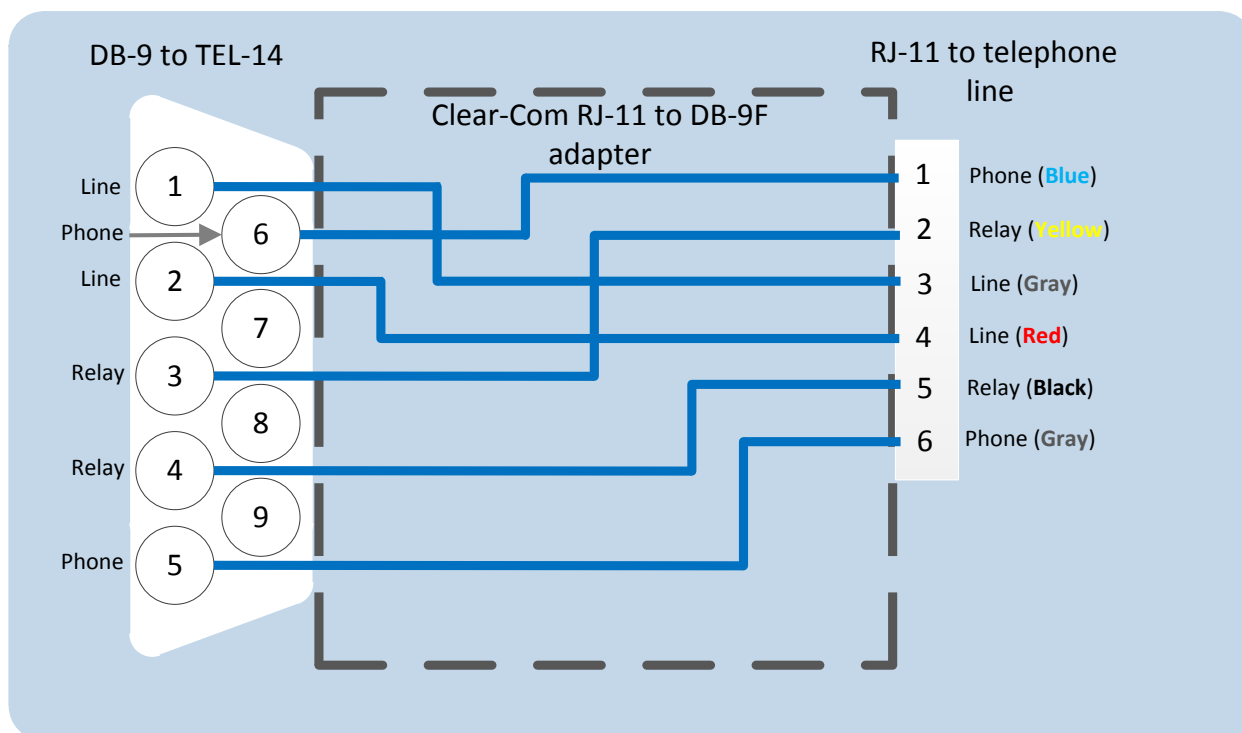

Figure 24: RJ-11 to DB-9 Adaptor for TEL-14 Interfaces

Note: The TEL-14 interface works with telephone company central office (CO) lines. Analog panel lines from some in-house PABXs are not compatible.

6.11.3.4 Using series-connected telephone sets with the TEL-14

Although it is possible to use a parallel-connected telephone set to originate calls, it is preferable to use a series-connected telephone set with the TEL-14. This prevents the impedance of the telephone set from disturbing the telephone line impedance recognized by the TEL-14.

It will also allow the TEL-14 to automatically disconnect the telephone when it comes “off-hook.” A standard telephone may be installed in series with the TEL-14 by connecting it to pins **1** and **6** of the **RJ-11 jack**. If telephones **must** be connected in parallel with the telephone line(s) during the TEL-14’s automatic nulling process, **all** additional standard telephones must be “on-hook”.

6.11.3.5 Using relay contacts with the TEL-14 interface

A pair of relay contacts for each telephone line rated at **2A** at **24 VAC** is available on the **DB-9** or the **RJ-11** of the adapter. This pair of contacts is normally open when the line is “on-hook,” and closes when the interface goes “off-hook”.

These contacts are not connected to any other circuitry inside the interface, and can be used to energize a line-in-use indicator light on a standard multiline phone set, or for any other low-power application.

6.11.4 Wiring scheme for the RLY-6 interface module

The RLY-6 interface module provides six fully programmable SPDT (single pole, double throw) relay outputs, to support dedicated switching functions external to the matrix .

RLY-6 interfaces can be:

- **Daisy chained to provide connection of up to 60 relays to the matrix.**
- **Mixed with GPI-6 modules up to the total limit of 60 items.** Five RLY-6 and five GPI-6 modules would provide 30 relays and 30 inputs for a total of 60 inputs and outputs.

Note: If both GPI-6 and RLY-6 interface modules are used the GPI-6 interface module must be placed first in the daisy chain.

For more information about wiring the RLY-6, see the ***RLY-6 manual***.

6.11.4.1 Wiring the RLY-6 to an IMF-3 interface frame

To connect the RLY-6 to the IMF-3 frame:

1. Connect one end of an RJ-45 cable (eight wires with no reversal) into the **GPI/RLY INTERFACE** connector on the back of the matrix.
2. Connect the other end into the top RJ-45 (**CH. A MATRIX**) connector for the RLY-6.

To connect an additional RLY-6 interface to the IMF-3 frame:

1. Connect one end of a short RJ-45 cable into the lower RJ-45 (**CH. B MATRIX**) for the first RLY-6.
2. Connect the other end of the cable into the top RJ-45 (**CH. A MATRIX**) connector for the additional RLY-6.

Additional RLY-6 Interfaces are added in the same way, using daisy-chain wiring. If there are multiple RLY-6 modules, the relays in the first module will be numbered **1 to 6**, the relays in the second module will be numbered **7 to 12**, and so on. **GPI-6** modules can be mixed in this daisy-chained scheme. The maximum combined length of all the RJ-45 cables should **not** exceed 20 feet (6 m).

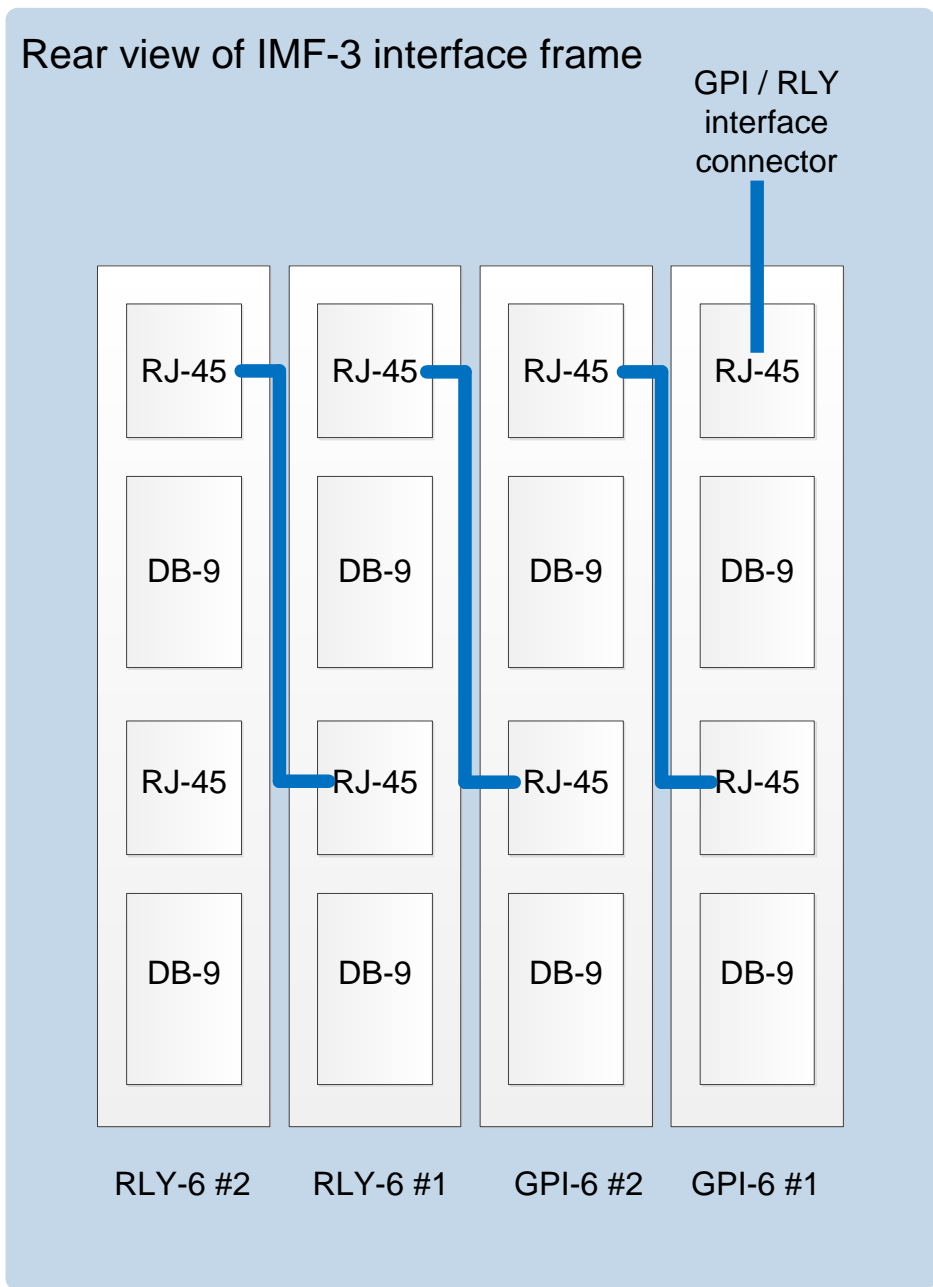

Figure 25: RLY-6/GPI-6 Daisy Chain Connection

Note: If both GPI-6 and RLY-6 interfaces are used the GPI-6 interfaces must be placed first in the daisy chain.

6.11.4.2 Wiring external devices to an RLY-6 interface module

To connect external devices to an RLY-6 interface module, use the two DB-9M connectors on the rear cable assembly panel for the interface module.

For the pin assignment of these connectors as viewed from the frame side of the connector, see **Figure 26: RLY-6 DB-9M connector pinout**.

If a DB-9F is plugged into the connector labeled **CH. A I/O**, relays 1 to 3 are available on that connector. The connector labeled **CH. B I/O** has the contacts for relays 4 to 6.

Note: In **Figure 26: RLY-6 DB-9M connector pinout**, the labels on the pins apply to either connector. For example, **#1/4 COM** refers to the wiper of **relay 1** if it is connected to **CH. A** and the wiper of **relay 4** if it is connected to **CH. B**.

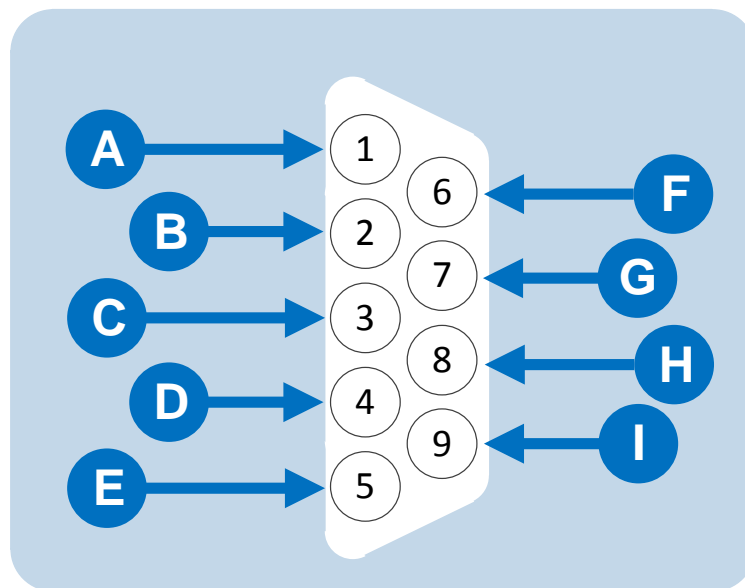

Figure 26: RLY-6 DB-9M connector pinout

Key to Figure 26: RLY-6 DB-9M connector pinout

Connector	Description
A	#1/4 Normally closed
B	#1/4 Normally open
C	#2/5 COM
D	#3/6 Normally closed

E	#3/6 Normally open
F	#1/4 COM
G	#2/5 Normally closed
H	#2/5 Normally open
I	#3/6 COM

Table 18: Key to Figure 26: RLY-6 DB-9M connector pinout

6.11.4.3 Wiring the RLY-6 to an IMF-102 interface frame

The wiring of an RLY-6 interface that is placed in an IMF-102 interface frame is the **same** as the wiring for a RLY-6 interface placed in an IMF-3 interface frame (see **Wiring the RLY-6 to an IMF-3 interface frame**).

The only difference is that an IMF-102 interface frame houses only two interfaces, which are mounted horizontally rather than vertically in the frame.

Note: **Figure 5: IMF-3 rear panel** and **Figure 6: IMF-102 rear panel** illustrate the differences between these interface frames.

For more information, see your **IMF-102** and **IMF-3** documentation.

To associate a relay to a label, use the EHX configuration software (see your **EHX** documentation and **EHX Help**).

6.11.5 Wiring schemes for a GPI-6 Interface module

The GPI-6 input interface module provides connection for six programmable inputs to the matrix so that each input can control a predefined matrix function.

Multiple GPI-6 interfaces can be daisy-chained to provide connection of **up to 60 inputs** to the matrix. RLY-6 and GPI-6 modules can be mixed together up to the **total limit of 60 items**.

Five RLY-6 and five GPI-6 modules would provide 30 relays and 30 inputs for a total of 60 inputs and outputs.

Note: If both GPI-6 and RLY-6 interface modules are used, the GPI-6 interface modules must be placed **first** in the daisy chain.

6.11.5.1 Wiring the GPI-6 to the IMF-3 interface frame

To connect the GPI-6 to the matrix:

1. Connect one end of an RJ-45 cable (eight wires with no reversal) into the **GPI/RLY INTERFACE** connector on the back of the frame.
2. Connect the other end into the top **RJ-45 (CH. A MATRIX)** connector for the **GPI-6**.

To connect an additional GPI-6 Interface module:

1. Connect one end of a short RJ-45 cable into the lower **RJ-45 (CH. B MATRIX)** for the first GPI-6.
2. Connect the other end of the cable into the top **RJ-45 (CH. A MATRIX)** connector for the additional GPI-6.

Additional GPI-6 Interface modules are added in the same way, using daisy-chain wiring. If there are multiple GPI-6 modules used, the inputs in the first will be numbered 1 to 6, second will be 7 to 12, etc.

RLY-6 modules can be mixed in this daisy-chained scheme. The maximum combined length of all the RJ-45 cables should not exceed **20 ft. (6 m)**.

6.11.5.2 Wiring the GPI-6 to external devices

To connect external devices to the GPI-6 interface, use the two DB-9M connectors on the rear cable assembly panel for the interface.

Figure 27: GPI-6 interface DB-9M connector pinout shows the pin assignment of these connectors as viewed from the frame side of the connector.

Note: If a DB-9F is plugged into the connector labeled **CH. A I/O**, inputs 1 to 3 are available on that connector.

Note: The connector labeled **CH. B I/O** has inputs 4 to 6. In **Figure 27: GPI-6 interface DB-9M connector pinout**, the labels on the pins apply to either connector.

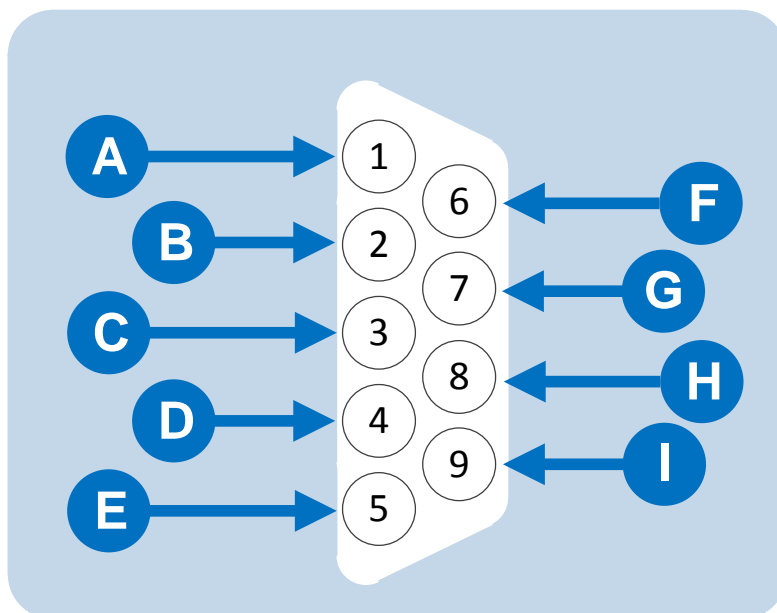

Figure 27: GPI-6 interface DB-9M connector pinout

Key to Figure 27: GPI-6 DB-9M connector pinout	
Connector	Description
A	#1/4 Input A
B	#2/5 Input A
C	#3/6 Input A
D	Ground
E	Ground
F	#1/4 Input B
G	#2/5 Input B
H	#3/6 Input B
I	Power source

Table 19: Key to Figure 27: GPI-6 DB-9M connector pinout

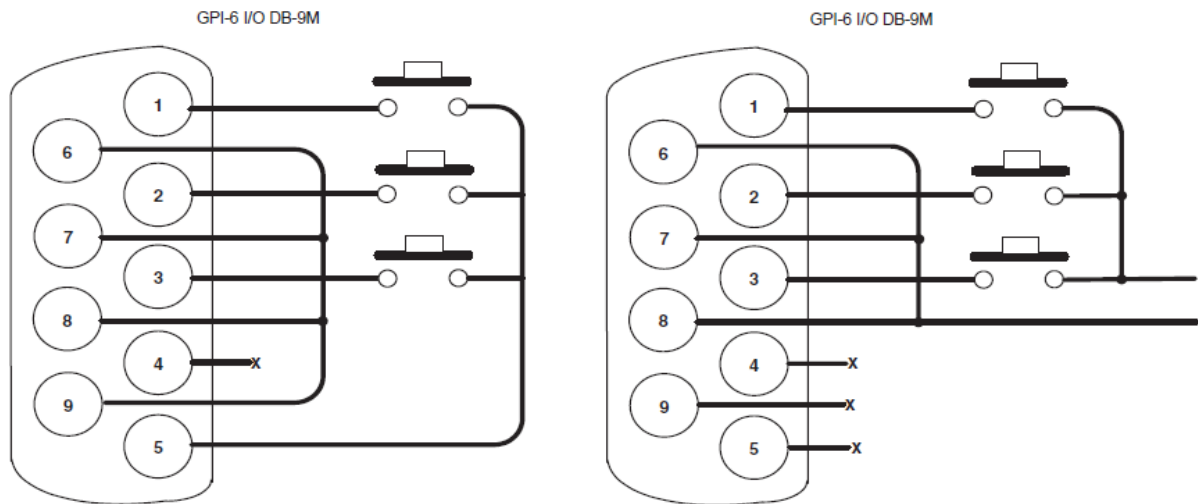

Figure 28: GPI-6 interface module examples

Figure 28 shows you how to connect switches or contacts using the power source provided by the GPI-6 module or powering switches from external sources. Each input can be wired to be isolated from each other as a further variation.

6.11.5.3 Wiring the GPI-6 to an IMF-102 interface frame

The wiring of a GPI-6 interface that is placed in an IMF-102 interface frame is the same as the wiring for a GPI-6 interface placed in an IMF-3 interface frame.

The only difference is that an IMF-102 interface frame houses only two interfaces, and they are mounted horizontally rather than vertically in the frame.

Note: **Figure 5: IMF-3 rear panel** and **Figure 6: IMF-102 rear panel** illustrate the differences between these interface frames.

For more information, see your **IMF-102** and **IMF-3** documentation.

Note: To define an input function, use the EHX configuration software (see your **EHX** documentation and **EHX Help**).

7 Connecting Matrices

You can connect your Eclipse HX matrices together, to expand the geographical range or the port density of a system. You can connect:

- Up to 64 Eclipse HX matrices (Eclipse HX-Omega, Eclipse HX-Median, Eclipse HX-Delta and Eclipse HX-PiCo) using **trunk lines** and an **Ethernet network**.
- Eclipse HX-Omega, Eclipse HX-Median and Eclipse HX-Delta matrices using **E-FIB** fiber interface cards and **fiber-optic** cable.
- Two Eclipse HX-PiCo matrices, using the **PiCo-Link** connector, to create non-blocking access to all audio ports on the two matrices.

Note: For an overview of the entire installation process, see **3Installation Overview**.

7.1 Intelligent linking

Intelligent linking dynamically allocates the available audio trunks as required when a **talk** or **listen** to another matrix system is requested. The Ethernet connection between matrices allows control data to route the audio lines so that any panel or interface on one matrix can communicate with panels or interface ports on the other matrices.

By doing so, the matrix can transparently handle communication requests so that an intercom panel user cannot distinguish between talking to a control room next door or across the continent. The Ethernet network extends the system's programming ability as well, because one computer on a network can control and monitor all matrices on the network.

Intelligent linking uses up available ports on the matrix, which means that it does **not** provide 100% routing. This type of connection is suitable:

- When only a restricted amount of inter-matrix communications is required (for example, when connecting studios).
- For wide area communications, such as remote systems that use public telecommunications networks, where only a small number of trunks are required.

Note: The matrices are configured for linking using EHX. For more information, see your **EHX documentation** (including **EHX Help**).

7.1.1 Intelligent linking with trunk lines

As many as 15 separate Eclipse HX-Omega, Eclipse HX-Median, Eclipse HX-Delta and Eclipse HX-PiCo matrices can be intelligently linked, using dedicated audio trunk lines and an Ethernet network. Audio travels between the matrices on the dedicated trunk lines, while control data travels on the Ethernet network.

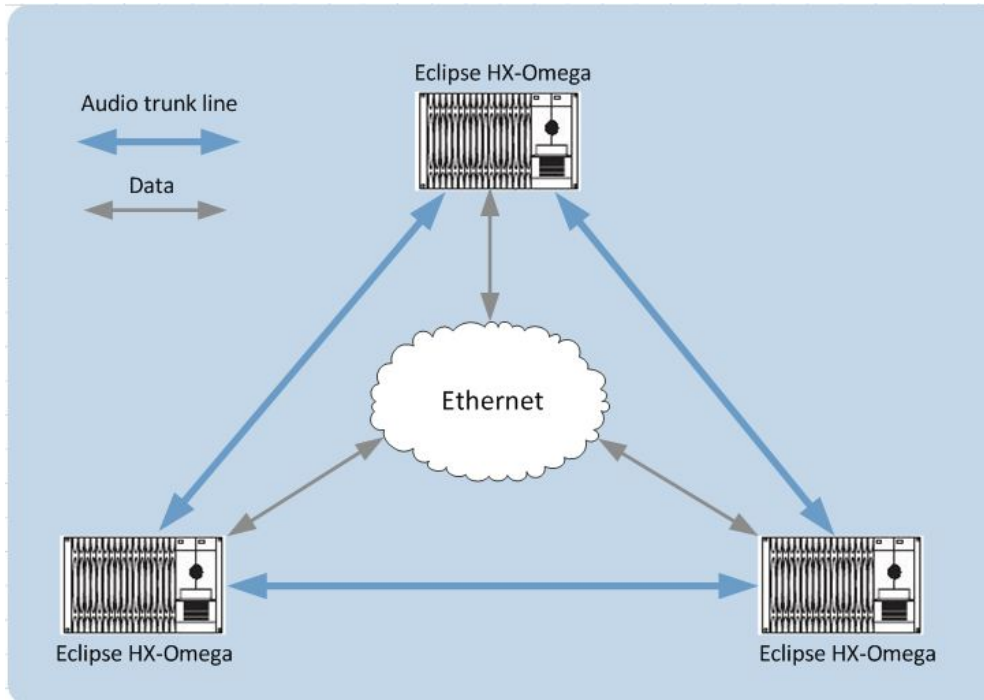

Figure 29: Intelligently linked Eclipse HX-Omega matrices

You can connect a dedicated audio trunk line using:

- The **receive** lines of an MVX-A16 serial port on one matrix and the appropriate **send** lines of an MVX-A16 serial port on the second matrix.
- An E-QUE interface module, **or** an E-FIB (Fiber) card and fiber optic cables.

Note: Only Eclipse HX-Median, Eclipse HX-Omega and Eclipse HX-Delta matrices can be connected using E-QUE / E-FIB cards and fiber optic cables.

7.1.2 Serial port to serial port linking

A specialised RJ-45 to RJ-45 jumper cable is required for serial port to serial port connections. You can either construct such a cable or use a punch-down block for the crossover wiring (see **Figure 30: Dedicated serial port audio trunk wiring**).

Note: The Seimon cable tester will **not** test this wiring.

The matrix is connected to an Ethernet network with the RJ-45 sockets labeled:

- **LAN 1** and **LAN 2** on the rear of the Eclipse HX-Omega, Eclipse HX-Median or Eclipse HX-Delta.
- The RJ-45 socket labeled **LAN** on the rear of the Eclipse HX-PiCo.

Note: Also applies to the E-32 matrix, the immediate predecessor of the Eclipse HX-PiCo.

The connectors have standard Ethernet pin assignments (see **Figure 31: LAN 1 and LAN 2 Ethernet connectors** and **Table 20: LAN 1 and LAN2 Ethernet connectors pinout**).

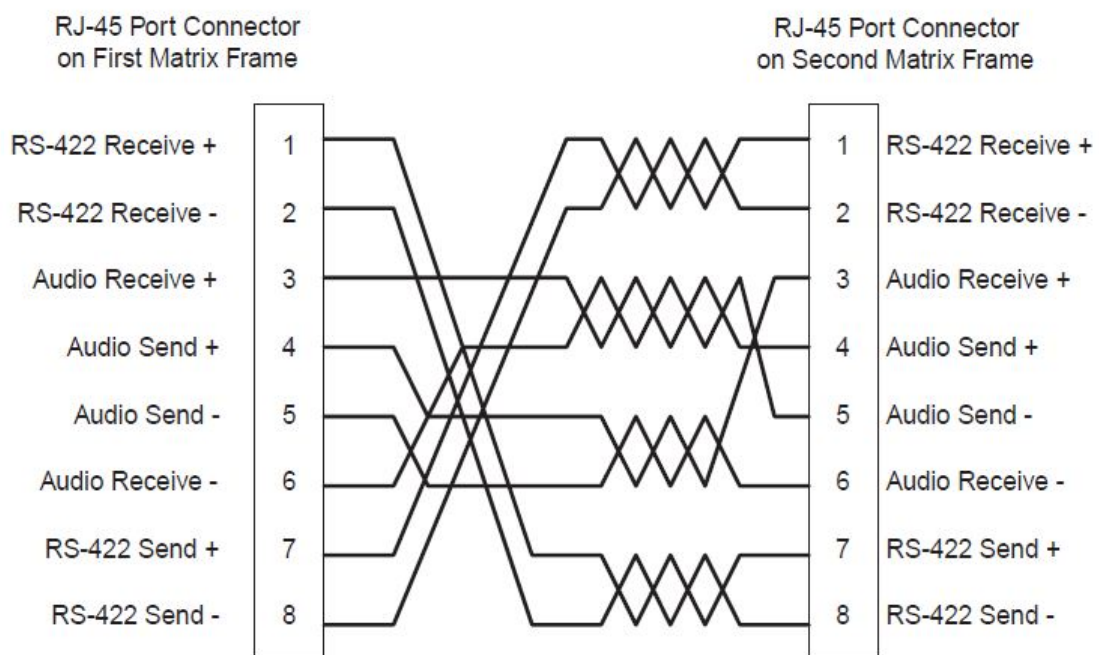

Figure 30: Dedicated serial port audio trunk wiring

LAN1 and LAN2
Ethernet RJ-45 Connectors

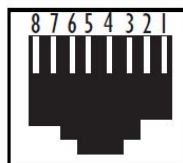

Figure 31: LAN 1 and LAN 2 Ethernet connectors

Pin	Description
Pin 1	Transmit data +
Pin 2	Transmit data -
Pin 3	Receive data +
Pin 4	Unused
Pin 5	Unused
Pin 6	Receive data -
Pin 7	Unused
Pin 8	Unused

Table 20: LAN 1 and LAN2 Ethernet connectors pinout

7.2 Linking Eclipse HX-Pico matrices with the PiCo-Link

You can create one non-blocking 64 port Eclipse HX system by connecting two Eclipse HX-PiCo matrices together, using the **PiCo-Link** RJ-45 connectors on the matrices.

This type of connection gives each connected matrix access to all of the audio ports of both matrices without using up ports for trunk lines (although logical routing such as IFBs, Telephone handling and ISOs **cannot** be used across the matrices).

To make this connection, use a specially constructed screened CAT5 cable of maximum length 1 meter (3.28 feet). The cable is wired as shown in **Table 21: HX-PiCo pinout for base loop linking**.

Cable End 1	Wire color	Cable End 2
Pin 1	White / orange	Pin 3
Pin 2	Orange	Pin 6
Pin 3	White / green	Pin 1
Pin 4	Blue	Pin 4
Pin 5	White / blue	Pin 5
Pin 6	Green	Pin 2
Pin 7	White / brown	Pin 7
Pin 8	Brown	Pin 8

Table 21: HX-PiCo pinout for base loop linking

Note: Hopping is not supported. DTMF generation and detection is only supported on 16 ports (ports 17 – 32) on each Eclipse HX-PiCo. The last four ports on an Eclipse HX-PiCo matrix are four-wire ports, and not available for panel connections.

Note: The matrices are configured for linking using EHX. For more information, see your **EHX documentation** (including **EHX Help**).

7.3 Tie-line (audio only) linking

You can directly connect two Eclipse HX matrices through tie-line linking. The tie lines between the matrices are wired as in **Figure 30: Dedicated serial port audio trunk wiring**.

By configuring each of the linked ports in each system as a partyline, the two systems can talk and listen to anyone on that partyline in either system. Call signals will also pass from one system to the other.

However, since no control data passes between the matrices, assignments cannot be dynamically allocated among the ports of a matrix. Only the one partyline on the first matrix connects to the partyline of the second matrix.

7.4 E1 / T1 linking

The E-QUE interface card, which can be fitted to the Eclipse HX-Omega, Eclipse HX-Median and Eclipse HX-Delta matrices, can be used to provide:

- Direct E1 to E1 port connections.
- Trunk linking, using a network between systems.
- T1 trunking between Eclipse HX systems, and between Eclipse HX systems and compatible third-party equipment.

Note: You can also use the E-QUE card for E & M signaling. For more information, see **6.8 E & M signalling with an E-QUE E1 / T1 interface card**.

Note: For more information about the E-QUE interface card, and other Clear-Com interface cards, see either:

- The *Eclipse HX-Omega User Guide*.
- The *Eclipse HX-Median User Guide*.
- The *Eclipse HX-Delta User Guide*.

7.4.1 E1 trunk connections

You can use the E-QUE interface card to make E1 connections between Eclipse systems or between Eclipse systems and compatible third-party equipment.

E1 mode provides 30 channels of G.722 encoded audio available on each of ports 1 and 5, giving 60 channels per card.

The **E1 specifications** are:

- HDB3 Encoding.
- Long Haul Receive Signal Level.
- E1 120 Ohm Transmit Pulse Amplitude.
- Balanced.
- 120 Ohm Line Impedance.
- No Signaling.
- G.722 64 kbit/s Audio Encoding.
- Tx Clock locally generated.
- Rx Clock Line Recovered.

Figure 32: Matrix to Matrix direct E1 Trunking shows E1 trunking using a direct connection between the matrices using a CAT5 crossover cable. The E-QUE interface should be set to **E1 Direct** in EHX hardware setup.

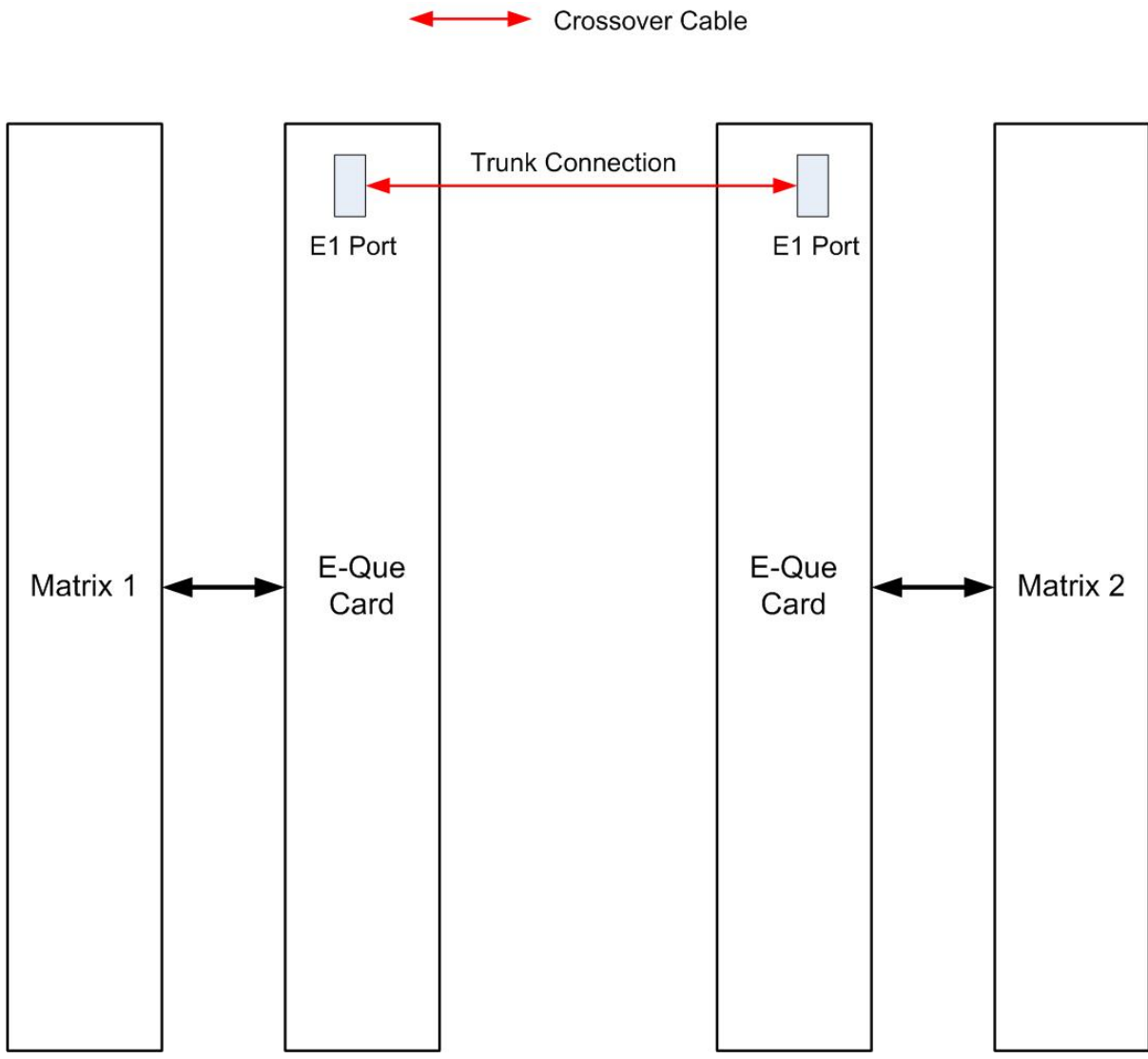

Figure 32: Matrix to Matrix direct E1 Trunking

E1 trunking between matrices can also be achieved over an E1 network, as shown

Figure 33: E1 Trunking with an E1 Network.

In this case E1 ports 1 and 5 of the E-QUE interface are connected using standard straight-through CAT5 cables rather than crossover CAT5 cables.

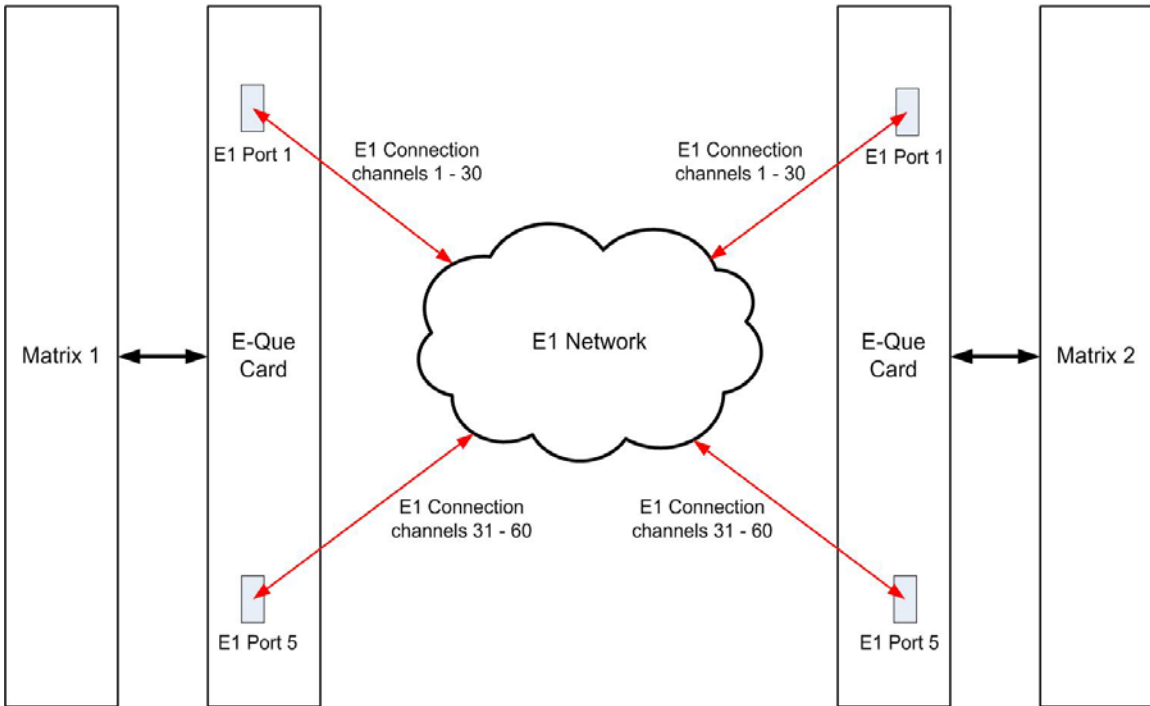

Figure 33: E1 Trunking with an E1 Network

The E-QUE interface can also be used to connect the matrix to third party equipment using E1 port 1 or 5.

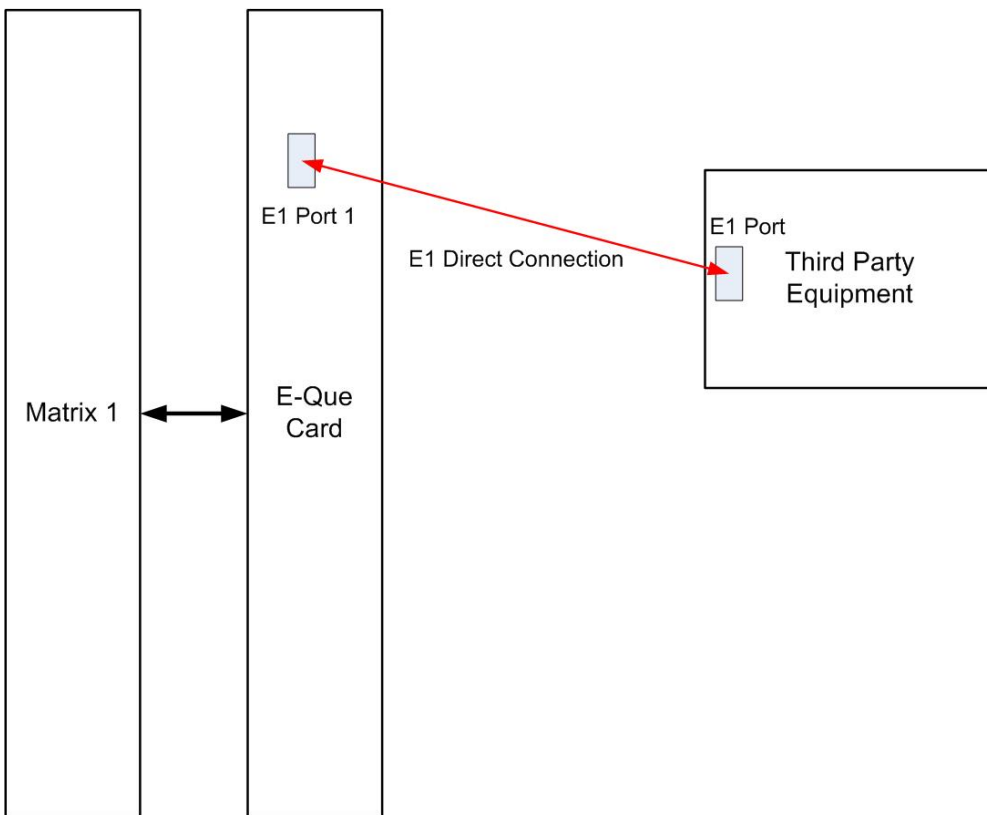

Figure 34: Matrix to Third Party E1 connection

The CAT5 cable connecting the E1 port on the E-QUE rear card may be a crossover cable or a straight-through cable depending on the requirements of the third party equipment. The E-Que interface should be set to **Direct** in EHX.

7.4.2 T1 trunking

The E-QUE interface card can provide T1 trunking between Eclipse HX systems and between Eclipse HX systems and compatible third-party equipment.

T1 mode provides 24 channels of G.722 encoded audio are available on each of ports 1 and 5, giving 48 channels per card.

The T1 trunking specifications are:

- B8ZS Encoding.
- Extended Super Frame.
- Long Haul Receive Signal Level.
- T1 Long Haul (LBO 0 dB) Transmit Pulse Amplitude.
- Balanced.
- 120 Ohm Line Impedance.
- No Signaling.
- G.722 64 kbit/s Audio Encoding.
- Tx Clock locally generated.
- Rx Clock Line Recovered.

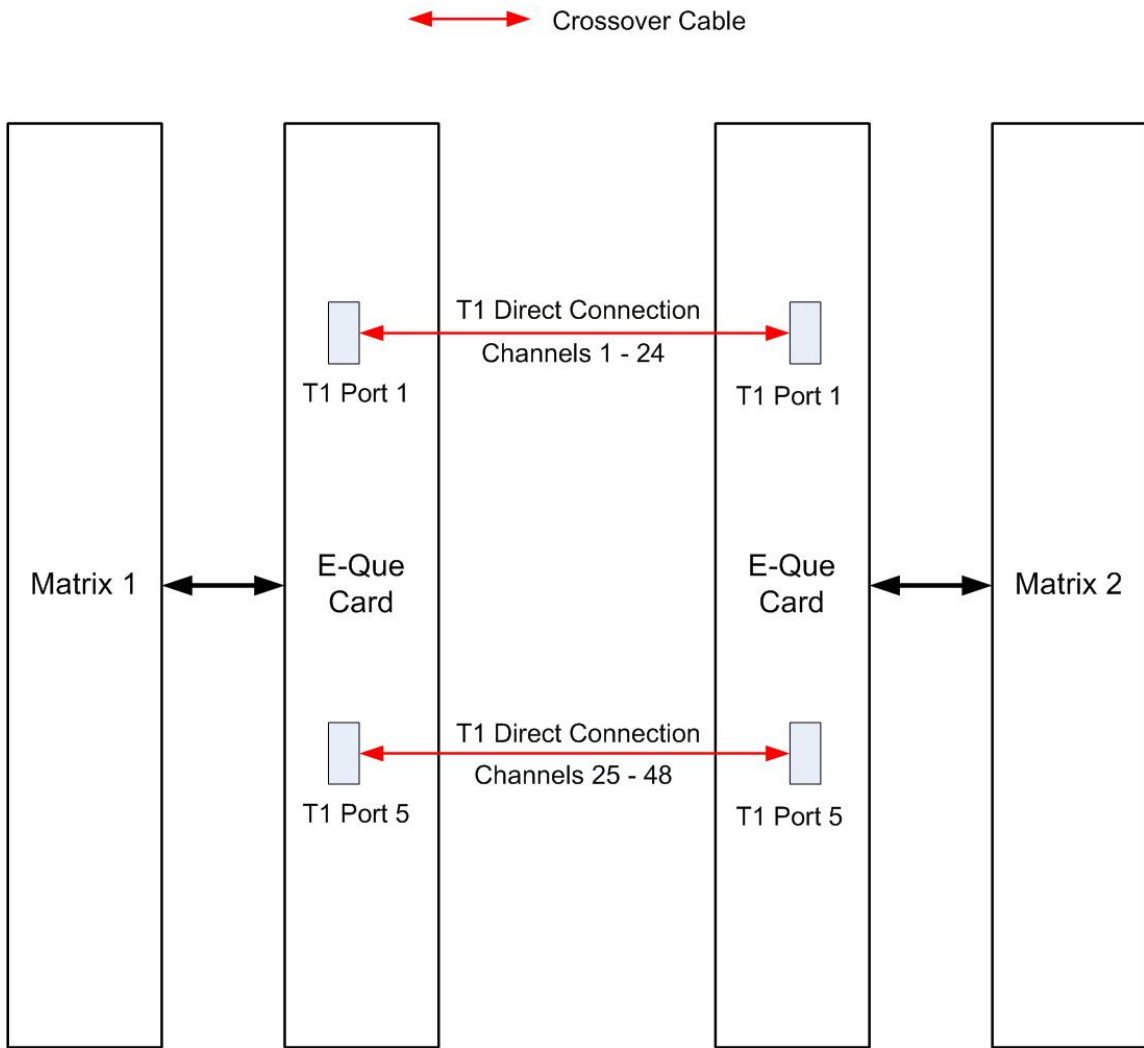

Figure 35: Matrix to Matrix T1 Trunking

T1 trunking between matrices can also be achieved over a E1 network as shown in **Figure 36: T1 Trunking using a E1 Network** .

In this case T1 ports 1 and 5 of the E-QUE rear card are connected using standard straight-through CAT5 cables rather than crossover CAT5 cables.

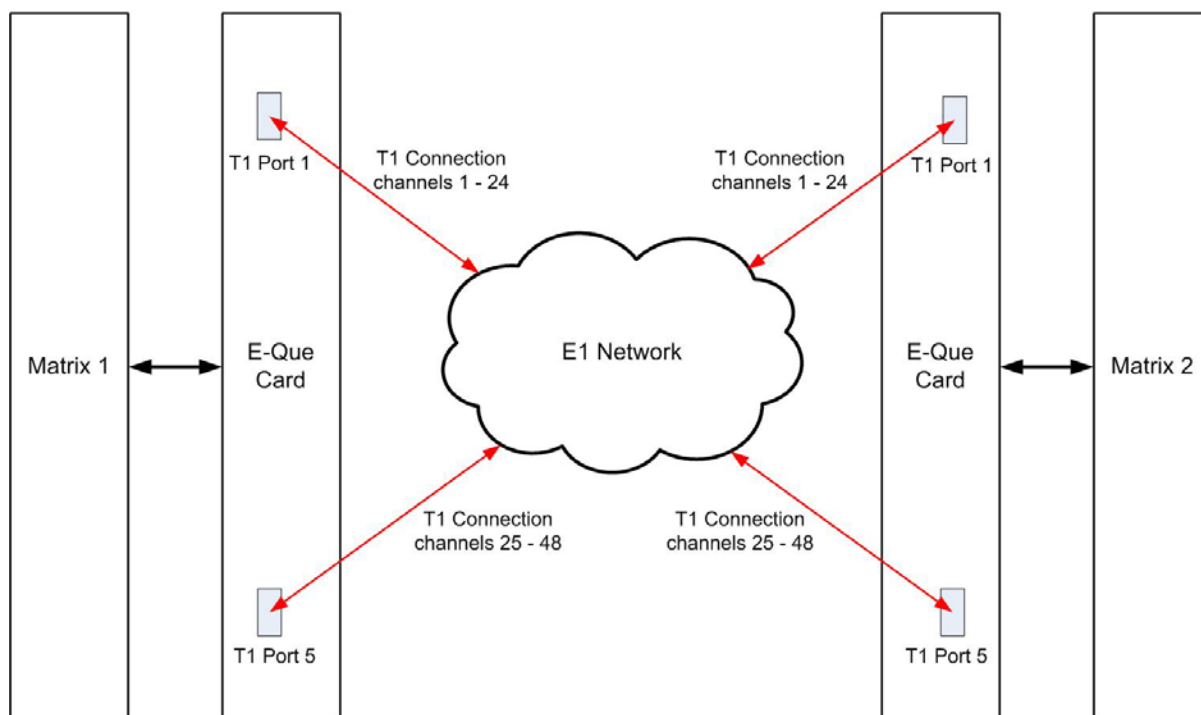

Figure 36: T1 Trunking using a E1 Network

7.4.2.1 E1/T1 trunking failover

Where the E1/T1 trunking has been configured with redundant trunks audio will be switched from the primary trunk to the backup trunk when a failure is detected.

When failover occurs from primary to backup there will be a three second audio break on any route running over the trunk.

If the trunk routing is later switched back from the backup trunk to the primary trunk there will be no loss of audio.

7.5 Fiber-optic linking

The E-FIB interface card is the fiber-net interface for the Eclipse HX-Omega, Eclipse HX-Median and Eclipse HX-Delta matrices. The card is supplied with main and backup fiber rings.

Note: For more information about the E-FIB interface card, and other Clear-Com interface cards, see:

- The *Eclipse HX-Omega User Guide*.
- The *Eclipse HX-Median User Guide*.
- The *Eclipse HX-Delta User Guide*.

Each fiber card link comprises:

- A front card with status indicators.
- A rear card with two Duplex LC terminated fiber optic connectors (TXVRA and TXVRB).

E-FIB cards use **9/125µ single mode fiber optic cables**. On the rear card, the TX1/RX1 connector is used for the main ring and the TX2/RX2 connector is used for the secondary ring. Single mode 9/125µ fiber optic cable should be used for connections and the matrices should be wired up with the system, with the lowest IP address being **system 1**.

Note: The standard maximum node length for fiber card connections is 10km, but other distances are available to special order.

The order of the fiber optic cable connections is reversed between the front and rear panels:

- On the front panel the primary connection is the upper set of indicators. The secondary connection is the lower set of indicators.
- On the rear panel the lower connector is the primary connection. The secondary connection is the upper connector.

Care should be taken when connecting or disconnecting the cables to ensure that they are connected correctly and **not** reversed.



A **protective plug** is usually fitted to the fiber connector sockets to protect them from damage or the entry of foreign materials. These should only be removed in order to fit the fiber optic cable. They should be replaced if the cable is unplugged.

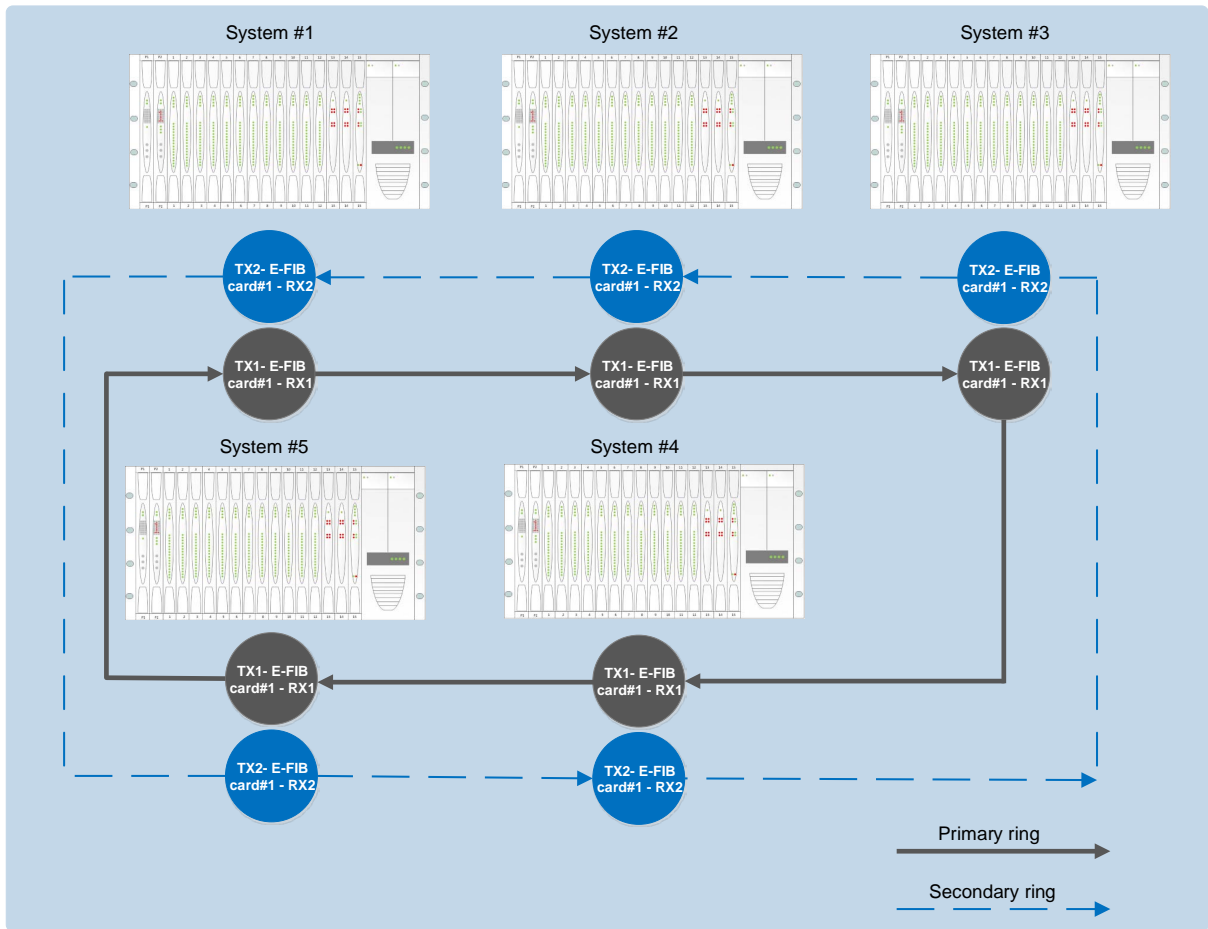

Figure 37: Fiber optic connected matrices

Term	Definition
Analog Port	Any of the Eclipse HX matrix's analog input/output RJ-45 connectors that are used to connect cable from the matrix to panels and interfaces. Each port connects to a separate audio channel in the matrix.
Alias label	A label that is temporarily assigned and replaces a previously labeled port or conference.
Bus	A bus is the channel or path between the components in the matrix along which electrical signals flow to carry information from one component to the next. In the Eclipse HX matrix the bus is located in the etched surface of the midplane.
Call signal	A call signal is an electronic signal sent from one panel or interface to another. A call signal can be audible and/or visual. Typically a call signal is sent to get the attention of a panel operator who may have turned down their intercom speaker's volume or removed their headset. It can also be sent to activate an electronic relay.
Category-5 (CAT5) cable	EIA/TIA 568 category specification relating to network cabling. Shielded category-5 cabling is required for Eclipse HX matrix wiring.
CellCom®	Digital wireless communications product. Sold under the CellCom name in USA and as FreeSpeak in Europe and Asia.
Central matrix	The term central matrix is used to differentiate the central hardware and software of the intercom system from the connected audio devices. The central matrix consists of: <ul style="list-style-type: none"> • The metal housing for the circuit cards and power supplies. • The circuit cards. • The power supplies. • The rear panel connectors which connect the matrix's hardware to panels and interfaces.
Conference	An internal matrix virtual partyline or busbar where many panels and interfaces can talk onto or listen from the party line without talking to themselves.
Destination	A device such as an intercom panel, beltpack, or interface to which audio signals are sent. The device from which audio signals are sent is called a source .
Duplex	All real-time communication between individuals talking face to face is full duplex, meaning that they can both talk and listen simultaneously. The Eclipse HX matrices provide full-duplex audio.

EHX	EHX is the Eclipse HX configuration software. EHX guides the operation of the matrix circuit cards and connected panels.
Ethernet	International standard which describes how information is transmitted across a network. Provides for the efficient organization of network components.
Fiber optic cable	A fiber-optic cable consists of a glass core covered with a reflective material called cladding and several layers of buffer coating to protect the cable from the environment. A laser sends light pulses through the glass core to the other end of the cable.
FreeSpeak®	Digital wireless communications product. Sold under the FreeSpeak name in Europe and Asia and CellCom name in USA.
FreeSpeak II™	Digital wireless communications product.
Full duplex	Refers to transmission of signals in two directions simultaneously.
Hopping	Refers to making a trunk connection through other matrices to a destination matrix.
IFB	<p>Interruptible Foldback. The term foldback refers to sending program audio / feed, or some other audio mix, back to announcers while they are on the air. Doing so allows announcers to monitor themselves, other announcers, videotapes of commercials, or some mix of sources, while they on the air. This is typically found in television news and live broadcast events.</p> <p>Announcers typically wear a small ear piece so they can hear the selected foldback audio mix. When a director wants to give directions to an announcer on air, or to announce changes in the program, the director must interrupt the foldback. To do this, the director uses a channel specifically set up to interrupt the foldback audio.</p>
Interface module	A piece of electronic hardware designed to convert the four-wire signals of a central matrix port to some other form of communication, such as 2-wire partyline, telephone, etc. The interface module is connected to a central matrix port. The external non-four-wire device is then connected to the interface module.
I-Series	<p>The I-Series is a family of Eclipse HX-supported user panels.</p> <p>The series includes two display stations, two non-display stations, two expansion panels, and a level-control panel.</p> <p>Eclipse HX also supports V-Series panels (see below).</p>
ISO	The ISO function, short for panel ISolation , allows a panel operator to call a destination and interrupt all of that destination's other audio paths and establish a private conversation. When the call is completed the destination's audio pathways are restored to their original state before the interruption.
Keygroup	KeyGroups provide a way of assigning a label to multiple panels simultaneously even within a networked matrix system. Once the KeyGroups have been defined using EHX, all the keys within a KeyGroup can be changed with a single assignment in Production Maestro (Pro mode only).

Label	<p>A label is an alphanumeric name of up to five characters that identifies a source, destination, or control function accessed by an intercom panel. Labels appear in the displays of the intercom panel.</p> <p>Labels can identify panels, ports interfaced to other external equipment, fixed groups, party lines, and special control functions.</p>
MADI	Multichannel Audio Digital Interface. The MADI or AES10 electronic communications protocol defines the data format and electrical characteristics of an interface carrying multiple channels of digital audio.
Multiplexing	The process by which two or more signals are transmitted over a single communications channel. Examples include time division and wavelength division multiplexing.
Non-volatile Memory	Data stored in the CPU's firmware (ROM) that is not lost when the power is turned off.
Palette	The port, keyGroup and Monitor selection screen in Production Maestro.
Panel	Any intelligent intercom device connected to the rear-panel analog ports of the central matrix. This term does not refer to devices connected through interface modules.
Partyline	A wired shared communication system based on a single screened pair of wires. See the Encore range. Matrix requires the CCI-22 to interface to it.
Port	Any of the input/output connections (RJ-45 connectors) on the back panel of the central matrix. These connectors and the attached cables connect the central matrix to remote intercom devices. The term port emphasizes that the connection is a portal between the central matrix and the remote intercom devices.
Program	Any separate audio source that is fed into the intercom channels. In television applications, for example, the program audio is the audio that is broadcast on air.
Rack Unit (RU)	Standardized unit of mounting space on a rack panel. Each rack unit is 1.75 inches (44.45 mm) of vertical mounting space. Therefore 1 RU is 1.75 inches (44.45 mm) of vertical mounting space, 2 RU is 3.5 inches (88.9 mm), 3 RU is 5.25 inches (133.35mm), and so on.
Remote panel	Any intelligent intercom device connected to the back-panel ports of the matrix. This term does not refer to devices connected through interfaces.

Sidetone	The sound of the panel operator's voice, as heard in their own earphone(s) as they speak.
Source	In this guide, the term source refers to a device (such as an intercom panel, interface, or beltpack) that sends audio into the matrix. The device to which audio is sent is called a destination.
VOX	In the Eclipse HX system, when audio at a panel exceeds a threshold, a light switches on at the panel's port card to visually cue the operator. The threshold level is set in the EHX configuration software.
V-Series	User panels used with Eclipse HX systems, providing advanced intercom facilities. Available in rack mount and desktop formats. I-Series user panels are also supported (see above).