

# User Guide



## Eclipse® HX-Omega

A user guide for  
Eclipse HX-Omega  
systems

Part Number: 399G268 Revision A  
27 July, 2018

## Document Reference

*Eclipse HX-Omega User Guide*

Part Number: 399G268 Revision A

## Legal Disclaimers

Copyright © 2018 HME Clear-Com Ltd.

All rights reserved.

Clear-Com, the Clear-Com logo, and Clear-Com Concert are trademarks or registered trademarks of HM Electronics, Inc.

The software described in this document is furnished under a license agreement and may be used only in accordance with the terms of the agreement.

The product described in this document is distributed under licenses restricting its use, copying, distribution, and decompilation/reverse engineering. No part of this document may be reproduced in any form by any means without prior written authorization of Clear-Com, an HME Company.

Clear-Com Offices are located in California, USA; Cambridge, UK, Dubai, UAE; Montreal, Canada; and Beijing, China. Specific addresses and contact information can be found on Clear-Com's corporate website:

[www.clearcom.com](http://www.clearcom.com)

## Clear-Com Contacts

### Americas and Asia-Pacific Headquarters

California, United States

Tel: +1 510 337 6600

Email: [CustomerServicesUS@clearcom.com](mailto:CustomerServicesUS@clearcom.com)

### Europe, Middle East, and Africa Headquarters

Cambridge, United Kingdom

Tel: +44 1223 815000

Email: [CustomerServicesEMEA@clearcom.com](mailto:CustomerServicesEMEA@clearcom.com)

### Beijing Representative Office

Beijing, P.R.China

Tel: +8610 65811360/65815577

# Contents

<b>1</b>	<b>Important Safety Instructions</b>	<b>6</b>
<b>2</b>	<b>Introduction</b>	<b>9</b>
2.1	Further information	9
<b>3</b>	<b>Overview</b>	<b>10</b>
3.1	Eclipse HX matrices	10
3.2	Eclipse HX-Omega matrix	11
3.3	CPU card	12
3.4	Interface cards	13
3.5	Interface modules	17
3.6	EHX configuration software	18
3.7	User panels	19
<b>4</b>	<b>Installing the Eclipse HX-Omega</b>	<b>20</b>
4.1	Before you begin the installation	21
4.2	Installing the Eclipse HX-Omega	23
4.3	Installing CPU cards	25
4.4	Installing interface cards	28
4.5	Wiring audio devices to the matrix	32
4.6	Wiring panels to the matrix	33
4.7	Wiring CPU card interfaces	34
4.8	DSE1/T1 Matrix to Matrix crossover cable connections	45
4.9	E1/T1 Matrix to Matrix straight cable connections	46
4.10	E1 to FreeSpeak® / CellCom® / FreeSpeak II™ antenna straight cable connection	46
<b>5</b>	<b>Using the Eclipse HX-Omega</b>	<b>48</b>
5.1	Creating and storing system configurations	48
5.2	Setting the default IP Address	49
5.3	Using the CPU card Ethernet ports	49
5.4	CPU card fail-safes	50
5.5	CPU card lights and controls	51
5.6	Analog port card (MVX-A16) front-panel lights and controls	57
5.7	Power supplies	59

5.8 *Diagnosing power supply problems* ..... 60

5.9 *Connecting the matrix* ..... 64

**6 E-MADI64 card .....68**

6.1 *E-MADI64 front panel lights and controls* ..... 69

6.2 *E-MADI64 rear panel connectors*..... 72

6.3 *MADI channels* ..... 73

6.4 *Setting up the E-MADI64 card* ..... 74

6.5 *V-Series Panels on E-MADI (Multi-channel Audio Digital Interface)* ..... 76

6.6 *Configuring binaural audio with E-MADI cards* ..... 78

6.7 *Configuring binaural panel audio in software* ..... 79

6.8 *Set the EHX Audio Mixer screen option for binaural audio routing*..... 80

6.9 *Upgrading the E-MADI64 card* ..... 81

**7 E-FIB fiber card .....82**

7.1 *E-FIB front panel lights and controls*..... 83

7.2 *E-FIB rear panel lights and connectors* ..... 86

7.3 *Configuring a fiber optic connection*..... 88

7.4 *Simplex fiber cabling* ..... 89

**8 E-Que E1 / T1 card .....94**

8.1 *Supported FreeSpeak / CellCom / FreeSpeak II connection options* ..... 94

8.2 *Supported direct and trunk connections (using the E1 and T1 protocols)*  
95

8.3 *E-Que front panel lights and controls*..... 96

8.4 *E-Que rear panel connectors* ..... 98

8.5 *Synchronization* ..... 99

8.6 *E-Que interface applications*..... 100

8.7 *E1 Trunk and Direct Modes* ..... 104

8.8 *T1 Trunking* ..... 107

8.9 *Trunking failover*..... 109

**9 IVC-32 card for IP-based connections .....110**

9.1 *IVC-32 front panel lights and controls* ..... 111

9.2 *IVC-32 rear panel connectors* ..... 113

9.3 *IVC-32 interface card applications*..... 114

**10 LMC-64 metering card .....116**

10.1 LMC-64 front panel lights and controls..... 117

10.2 LMC-64 rear panel connectors ..... 119

10.3 LMC-64 interface card applications ..... 120

**11 E-Dante64-HX card .....122**

11.1 Example applications ..... 123

11.2 Using the E-DANTE64-HX card ..... 125

11.3 E-DANTE64-HX front panel lights and controls ..... 126

11.4 E-DANTE64-HX rear panel lights and controls ..... 128

11.5 Network configuration..... 129

11.6 Installing a replacement or backup card..... 129

11.7 Upgrading your E-DANTE64-HX card..... 130

11.8 Troubleshooting: Sample rate..... 133

11.9 Troubleshooting: I need to find the E-Dante64 card’s IP address.... 133

**12 E-IPA-HX high capacity IP to matrix card .....139**

12.1 Licenses..... 146

12.2 Card capacity ..... 147

12.3 E-IPA-HX rear connectors..... 149

12.4 E-IPA-HX front lens indicators..... 151

12.5 Adding an E-IPA-HX card (automatic discovery) ..... 153

12.6 Adding an E-IPA-HX card (manual)..... 153

12.7 Network setup for the E-IPA-HX card ..... 156

12.8 Port security settings..... 159

12.9 Upgrade the E-IPA-HX card ..... 160

**13 Maintaining the Eclipse HX-Omega .....163**

13.1 Routine maintenance recommendations ..... 163

13.2 Fail-Safe modes ..... 164

13.3 Troubleshooting ..... 165

13.4 System block diagram ..... 171

**14 Compliance .....172**

**15 Specifications .....175**

15.1 Matrix capabilities ..... 175

15.2 Mechanical ..... 176

15.3	<i>Environmental</i>	176
15.4	<i>Matrix performance</i>	177
15.5	<i>E-MADI64 interface front card</i>	177
15.6	<i>E-MADI64 interface rear card</i>	178
15.7	<i>E-MADI64 fiber cable</i>	178
15.8	<i>E-MADI64 fiber transceiver</i>	178
15.9	<i>E-MADI64 clock sources</i>	179
15.10	<i>Fiber interface front card</i>	180
15.11	<i>Fiber interface rear card</i>	180
15.12	<i>Fiber cable</i>	180
15.13	<i>Fiber transceiver</i>	180
15.14	<i>E-Que interface front card</i>	182
15.15	<i>E-Que interface rear card</i>	182
15.16	<i>IVC-32 interface front card</i>	182
15.17	<i>IVC-32 interface rear card</i>	184
15.18	<i>LMC-64 interface front card</i>	184
15.19	<i>LMC-64 interface rear card</i>	185
15.20	<i>E-DANTE64-HX interface front card</i>	185
15.21	<i>E-DANTE64-HX interface rear card</i>	185
15.22	<i>E-Dante64-HX LAN connectors</i>	185
15.23	<i>E-Dante64-HX SFP modules</i>	186
15.24	<i>E-Dante64-HX sample rates and available channels</i>	186
15.25	<i>E-IPA-HX card</i>	187
15.26	<i>Analog port cards (MVX-A16) (MK1 and MK2)</i>	187
15.27	<i>Data interface: 16 bi-directional</i>	188
15.28	<i>Backplane connector: FCI/BERG Metral</i>	188
15.29	<i>System programming</i>	188
15.30	<i>Minimum PC requirements (for EHX software)</i>	189
15.31	<i>Recommended PC requirements (for EHX software)</i>	190
15.32	<i>Power supply unit</i>	191
<b>16</b>	<b>Glossary</b>	<b>192</b>

# 1 *Important Safety Instructions*

---

- 1) Read these instructions.
- 2) Keep these instructions.
- 3) Heed all warnings.
- 4) Follow all instructions.
- 5) Do **not** use this apparatus near water.
- 6) Clean only with dry cloth.
- 7) Do **not** block any ventilation openings. Install in accordance with the manufacturer's instructions.
- 8) Do **not** install near any heat sources such as radiators, heat registers, stoves, or other apparatus (including amplifiers) that produce heat.
- 9) Do **not** defeat the safety purpose of the polarized or grounding-type plug. A polarized plug has two blades and a third grounding prong. The wide blade or the third prong are provided for your safety. If the provided plug does not fit into your outlet, consult an electrician for replacement of the obsolete outlet.
- 10) Protect the power cord from being walked on or pinched particularly at plugs, convenience receptacles, and the point where they exit from the apparatus.
- 11) Only use attachments/accessories specified by the manufacturer.
- 12) Use only with the cart, stand, tripod, bracket, or table specified by the manufacturer, or sold with the apparatus. When a cart is used, use caution when moving the cart/apparatus combination to avoid injury from tip-over.
- 13) Unplug this apparatus during lightning storms or when unused for long periods of time.
- 14) Refer all servicing to qualified service personnel. Servicing is required when the apparatus has been damaged in any way, such as power-cord supply or plug is damaged, liquid has been spilled or objects have fallen into the apparatus, the apparatus has been exposed to rain or moisture, does not operate normally, or has been dropped.

- 15) **Warning:** To reduce the risk of fire or electric shock, do not expose this product to rain or moisture.

## Safety Symbols

Familiarize yourself with the safety symbols in **Figure 1-1: Safety symbols**. These symbols are displayed on the apparatus and warn you of the potential danger of electric shock if the system is used improperly. They also refer you to important operating and maintenance instructions in the product user manual.

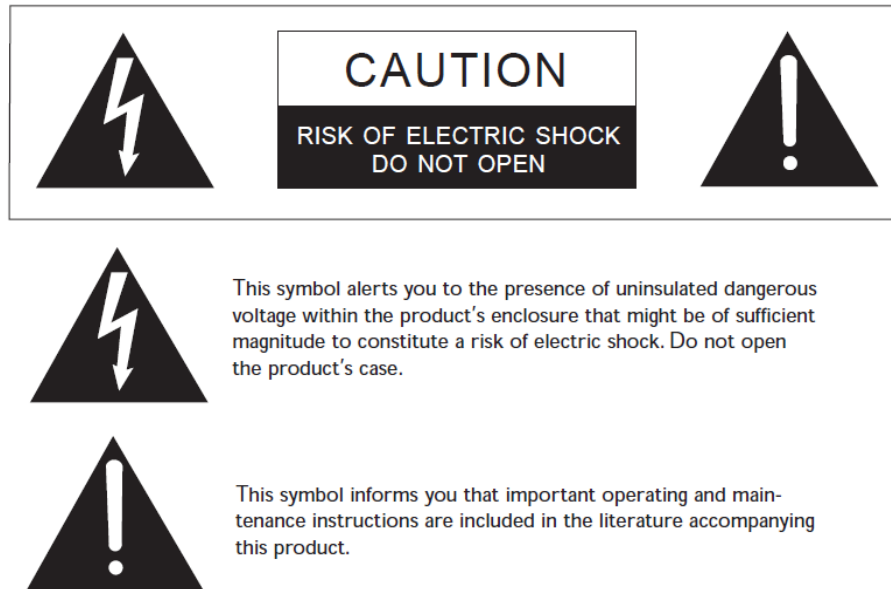

**Figure 1-1: Safety symbols**

## Mains Power Cord

Eclipse Matrix devices are powered by an internal power supply. The cord to connect the internal power supply to the mains supply must conform to the following:

- The mains power cord shall have an **IEC C13 connector** at one end and a mains power plug at the other end.
- An **IEC C13 plug** has three pins, the center pin carrying the earth / ground. The other two pins carry neutral and live circuits.
- The conductors of the mains cords shall have adequate cross-sectional area for rated current consumption of the equipment.
- The mains plug that connects to the mains supply must be approved for use in the country where the equipment is to be used.
- The mains power cord must be an **IEC mains power cord** complying with standard **IEC60320; IEC320/C13**.
- Mains power cords used in the U.S. must also comply with standard **UL817**.

## 2 Introduction

---

The Eclipse HX system is a digital point-to-point intercom platform, designed to seamlessly integrate your entire your entire intercom infrastructure (digital, wireless, IP-based and analog intercom systems). The system comprises matrices, interface cards and modules, user panels and interface matrices.

At the heart of the system is the central matrix, comprising a system matrix and the highly intuitive EHX configuration software, run from an external PC. The **Eclipse HX-Omega User Guide** describes how to use the largest and most powerful system matrix in the Eclipse product range, the **Eclipse HX-Omega**.

The guide:

- Provides an overview of the Eclipse HX-Omega matrix, including the interface modules and cards that you can fit to the matrix.
- Describes how to install, use and maintain an Eclipse HX-Omega matrix.
- Describes how to use E-FIB fiber interface cards to link matrices together.
- Describes how to use the E-Que, IVC-32, E-MADI64 and LMC-64 interface cards.
- Provides detailed specifications for the Eclipse HX-Omega.

**Note:** For more detailed information about installing an Eclipse HX system, see the *Eclipse HX System Frame (Matrix) Installation Guide*.

For more information about EHX, see your EHX documentation, including *EHX Help* (integrated with your software).



**Servicing instructions are for use by qualified personnel only. To reduce the risk of electric shock, do not perform any servicing other than that described by this guide, unless qualified to do so. Refer all servicing to qualified service personnel.**

### 2.1 Further information

For more information about any of the Eclipse HX system components (devices) referenced in this guide (including matrices, intercom cards, interface modules and software), see the specific manual / documentation for that device or software.

Eclipse HX documentation is available from:

- Your product DVD-ROM.
- The Clear-Com website (<http://www.clearcom.com/product/digital-matrix>).

For sales information, see your Clear-Com sales representative. For contact information, see Page 2 of this guide.

## 3 Overview

This chapter provides an overview of the Eclipse HX-Omega matrix, including the extension cards and interface modules that can be fitted to the matrix.

### 3.1 Eclipse HX matrices

There are **four** types of Eclipse HX system matrix available from Clear-Com:



Matrix	Description
<p><b>Eclipse HX-Omega</b></p> 	<p>The largest matrix in the Eclipse HX range.</p> <p>The Eclipse HX-Omega has slots for</p> <p>2 CPU cards and 15 interface cards in a six rack unit (6RU) frame.</p> <p>For more information, see this guide.</p>
<p><b>Eclipse HX-Median</b></p> 	<p>The Eclipse HX-Median has slots for:</p> <p>2 CPU cards, 7 interface cards, and 8 interface modules in a six rack unit (6RU) frame.</p> <p>For more information, see the <b><i>Eclipse HX-Median User Guide</i></b>.</p>
<p><b>Eclipse HX-Delta</b></p> 	<p>The Eclipse HX-Delta has slots for 2 CPU cards, 4 interface cards and 3 interface modules in a three rack unit (3RU) frame.</p> <p>For more information, see the <b><i>Eclipse HX-Delta User Guide</i></b>.</p>
<p><b>Eclipse HX-PiCo</b></p> 	<p>The Eclipse HX-PiCo provides up to 32 panel and 4 additional four-wire ports in a one rack unit (1RU).</p> <p>For more information, see the <b><i>Eclipse HX-PiCo User Guide</i></b>.</p>

Table 3-1: Eclipse HX Matrices

## 3.2 Eclipse HX-Omega matrix

A complete Eclipse HX-Omega system consists of a central matrix and the remote audio devices (such as user panels, interface cards, interface modules, 4-wire devices and intercom systems) connected to it.

**Note:** The term **central matrix** is used to differentiate the core hardware and software from the connected user panels, interface modules and other intercom devices. The central matrix itself consists of the matrix hardware (the Eclipse HX-Omega matrix) and the EHX configuration software.

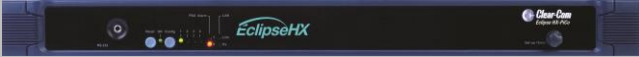
### 3.2.1 Chassis and assembly

The **matrix chassis** is a metal rectangular box which measures six rack units (6RU) high and 19-inches wide (26.9 cm x 48.3 cm). It has slots for 2 CPU cards, and 15 interface cards. It has 2 power supplies.

RJ-45 and fiber-optic connectors are located on removable plates on the rear of the chassis. These connect the CPU and interface cards to intercom devices and media such as user panels, interfaces, four-wire audio equipment, wireless equipment and fiber-optic cables.

The matrix assembly consists of the following components:

- The metal chassis for the circuit cards and power supplies.
- The removable and replaceable circuit cards.
- The removable and replaceable power supplies.
- The rear panel connectors which link the circuit cards to devices and media such as intercom panels, interfaces, wireless equipment and optical fiber.

### 3.2.2 Power supplies

The Eclipse HX-Omega matrix has **two Euro Cassette power supply units** that can be easily installed or removed as needed. One power supply unit can power an entire matrix. The second unit provides a backup in case of failure or damage to the first unit.

In addition, the two supplies have separate IEC connectors to AC mains, and are designed for completely automatic and transparent changeover between supplies in the event of a power outage in one of the AC mains circuits.

An over-temperature sensor is connected to both an audible failure alarm and a warning light, allowing the system operator to diagnose and correct any power anomalies while the system remains operational.

### 3.2.3 Main features of the Eclipse HX-Omega

Features of the Eclipse HX-Omega matrix system include:

- Full audio bandwidth throughout the signal chain, producing superior broadcast audio quality. The system maintains 24-bit sampling and 30 Hz to 22 kHz frequency response.
- Support for multiple analog port interfaces (MVX-A16), providing 16 analog ports each. If MVX-A16 cards are fitted to all 15 slots available, the Eclipse HX-Omega can provide up to 240 analog ports.
- Fail-safe redundancy achieved by two processor cards and two power supplies.
  - Note:** Power supplies automatically switch to the correct voltage, for compatibility around the world.
- Eight general purpose inputs and eight relays, located directly on the matrix.
- Full compatibility with V-Series and i-Series user panels.
- Matrices that link across cities, nations, or continents through trunk lines and fiber.
- The same fiber-networking interface (E-FIB) as the Eclipse HX-Median and Eclipse HX-Delta matrices.
- Connection to FreeSpeak / CellCom / FreeSpeak II antennas and splitters using the E-Que interface.
- Connection to IP enabled V-Series panels and Concert users over IP networks using the IVC-32 interface.
- Audio level metering over IP networks using the LMC-64 interface card.
- Up to 64 duplex channels of AES3 audio over a coaxial cable or fiber pair using the E-MADI64 interface card.
- VOX-programmable audio, which visually cues you at the matrix when audio transmits at a programmed threshold on a connected intercom panel or interface.
- Virtual operation in which a complete networked system can be operated and maintained from anywhere in the world. The system provides both local area network and Internet access to the central matrix.
- Visual and intuitive EHX configuration software.

### 3.3 CPU card

Two CPU cards are fitted to each Eclipse HX-Median system, in a master and slave relationship. The second CPU card provides redundancy in the case of outages or planned maintenance.

The master CPU card:

- Provides the serial data and Ethernet connection to the connected EHX PC.

- Coordinates the data flow between the other interface cards and modules in the system, allowing them to communicate with each other.
- Stores up to four complete configurations, enabling the selection and activation of a configuration directly from the card.
- Includes an additional, embedded configuration, which may be activated from the card for fast fault checking after the installation or upgrade of the Eclipse HX system.

**Note:** A configuration determines the operating parameters of the Eclipse HX matrix system, including port functions, talk-and-listen audio routes, controls and other functions. Configurations are created and managed in EHX, for download to the matrix or matrices. For more information about EHX, see **3.6 EHX configuration software**.

The cards slide vertically into the front of the matrix and connect to the backplane.

## 3.4 Interface cards

### 3.4.1 MVX-A16 Analog port card

An MVX-A16 analog port card controls the operation of panels and interfaces connected to it. Panels and interfaces connect to the port card through an RJ-45 connector (port) on the HX-Omega rear panel. Shielded category-5 cable attaches the panel or interface to the RJ-45 connector.

The MVX-A16 analog port card sends balanced audio and RS-422 data signals to connected audio equipment through 4-pair shielded category-5 cable. The card connects up to 16 audio devices (such as intercom panels, interfaces, or 4-wire audio equipment) to the central matrix.

Each audio device connected to a port card communicates with all other audio devices in the system and with the central matrix.

For intelligent linking, shielded CAT-5 cable is run from a port on one Eclipse HX-Omega matrix to a port on a second Eclipse HX-Omega matrix to form a trunkline connection.

**Note:** For the order in which all interface cards must be installed to the Eclipse HX-Omega, see **4.5 Installing interface cards**.

**Note:** The term **central matrix** is used to differentiate the core hardware and software from the connected intercom panels and interfaces. The central matrix itself consists of the matrix hardware (the Eclipse HX-Omega matrix) and the EHX configuration software.

Cards slide vertically into the front of the matrix and connect to the backplane.

### 3.4.2 E-FIB fiber interface card

E-FIB fiber interfaces connect Eclipse HX matrices together to provide a high speed, dual redundant link to transfer audio samples and data between systems. These connections can be configured in various ways to provide protection against the loss of a link or a node.

Each E-FIB fiber interface comprises:

- A front card with various status indicators.
- A rear card with two Duplex LC Terminated fiber optic connectors (**TXVRA** and **TXVRB**).

E-FIB interfaces should be fitted to slot 14 or 15 of the HX-Omega matrix (furthest away from the CPU cards).

**Note:** For the order in which all interface cards must be installed to the Eclipse HX-Omega, see **4.5 Installing interface cards**.

Cards slide vertically into the front of the matrix and connect to the backplane.

### 3.4.3 E-Que E1/T1 interface card

The E-Que E1/T1 interface allows the Eclipse HX matrix to connect to FreeSpeak/CellCom/ FreeSpeak II antennas and FreeSpeak/CellCom/ FreeSpeak II antenna splitters.

Each E-Que interface comprises:

- A front card with a reset button and various status indicators.
- A rear card with eleven RJ-45 ports giving eight standard ports, DECT sync in and out and a LAN port for diagnostic use.

Each E-Que front card has status LEDs for power, port activity and LAN status. The port activity LEDs show when

- A device is connected to an E1 port.
- A connection has been established between the E1 port and the connected device.

A total of four E-Que, IVC-32 or LMC-64 interface cards may be fitted to an Eclipse HX-Omega unless the matrix is fitted with a Power-One PSU. If the matrix has a Power-One PSU, up to six E-Que, IVC-32 or LMC-64 cards may be fitted with the following condition:

- You can only have four wireless E-Que cards
- You can only have four E-Que cards with EM signaling enabled.

For the order in which all interface cards must be installed to the Eclipse HX-Omega, see **4.5 Installing interface cards**.

**Note:** The EHX configuration software provides E1 and T1 trunking (see **3.6 EHX configuration software**).

Cards slide vertically into the front of the matrix and connect to the backplane.

### 3.4.4 E-MADI64 card

The E-MADI64 is a MADI (*Multichannel Audio Digital Interface*) card, providing up to 64 duplex channels of AES3 digital audio over a coaxial cable or fiber pair between compatible devices. The E-MADI64 card supports both direct and trunk connections.

The E-MADI64 card supports up to 32 V-Series Panels over a suitable infrastructure. See 6.5 V-Series Panels on E-MADI (Multi-channel Audio Digital Interface) for more information

**Note:** You have the option in EHX to limit the E-MADI64 card to either 32, 56 or 64 channels of audio. All MADI channels have standard EHX settings, including VOX and in-use tally. See also **6 E-MADI64 card**.

Each E-MADI64 card set comprises:

- A front card with pin reset and various status indicators (including channel quantity, sample rate, power and diagnostic (active and error) indicators).
- A rear card with a MADI fiber connector, MADI input and output coaxial cable connectors, and coaxial Video / Word clock input.

**Note:** For the order in which all interface cards must be installed to the Eclipse HX-Omega, see **4.5 Installing interface cards**.

Cards slide vertically into the front of the matrix and connect to the backplane.

### 3.4.5 IVC-32 IP interface card

The IVC-32 interface allows the Eclipse matrix to connect to IP enabled V-Series panels, other matrices and Concert users via an IP network.

Each IVC-32 interface comprises:

- A front card with a reset button and various status indicators.
- A rear card with eleven RJ-45 ports giving eight E1/T1 ports (not used), DECT sync in and out (not used) and a LAN port for IP connectivity.

Each IVC-32 front card has status LEDs for power, port activity and LAN status. The LAN indicators show whether there is a LAN connection and the IP activity on the LAN port.

A total of four E-Que, IVC-32 or LMC-64 interface cards may be fitted to an Eclipse HX-Omega unless the matrix is fitted with a Power-One PSU. If the

matrix has a Power-One PSU, up to six E-Que, IVC-32 or LMC-64 cards may be fitted with the following condition:

- You can only have six wireless E-Que cards
- You can only have four E-Que cards with EM signaling enabled.

**Note:** For the order in which interface cards must be installed to the Eclipse HX-Omega, see **4.5 Installing interface cards**.

Cards slide vertically into the front of the matrix and connect to the backplane.

### **IVC-32 Redundant Card**

You can add an IVC-32 Redundant Card that provides fail-over redundancy for one or more IVC-32 Cards in the matrix.

An IVC-32 Card will fail-over to the IVC-32 Redundant Card under the following conditions:

- • All configured VoIP ports are unconnected for longer than 90 seconds.
- • The IVC-32 Card is detected as absent from the VME backplane.
- • It is requested via the EHX Event Log.

A switch back from a redundant card back to a failed card only occurs under the following condition:

- The redundant card has failed. If the original card is still in error, then it will switch back and forward until corrective action is taken.

## **3.4.6 LMC-64 interface card**

The LMC-64 interface allows the Eclipse HX matrix to provide Production Maestro Pro (routing software) clients with audio level metering of Party Lines (Conferences) and 4-Wire ports via an IP network.

Each LMC-64 interface comprises:

- A front card with a reset button and various status indicators.
- A rear card with eleven RJ45 ports giving eight E1/T1 ports (not used), DECT sync in and out (not used) and a LAN port for IP connectivity.

Each LMC-64 front card has status LEDs for power, port activity and LAN status. The LAN indicators show whether there is a LAN connection and the IP activity on the LAN port.

A total of four E-Que, IVC-32 or LMC-64 interface cards may be fitted to an Eclipse HX-Omega unless the matrix is fitted with a Power-One PSU. If the matrix has a Power-One PSU, up to six E-Que, IVC-32 or LMC-64 cards may be fitted with the following condition:

- You can only have four wireless E-Que cards
- You can only have four E-Que cards with EM signaling enabled.

**Note:** For the order in which interface cards must be installed to the Eclipse HX-Omega, see **4.5 Installing interface cards**.

Cards slide vertically into the front of the matrix and connect to the backplane.

### 3.4.7 E-DANTE64-HX interface card

This is a Clear-Com matrix interface card that is enabled to work with Dante network protocols and software. Using the E-Dante64 card, you can transport many channels of high quality audio via a Clear-Com matrix to multiple Dante enabled devices using standard Ethernet network structure (up to 64 channels per E-DANTE64 card).

You can configure each E-DANTE64-HX card with EHX configuration software to support up to 16, 32 or 64 cards.

**Note:** Dante enabled devices also interface with AES67 devices.

Each E-DANTE64-HX card set consists of:

- A front panel with a reset button and status LEDs
- A rear panel with network connectors and status LEDs.

For more information, see **11 E-Dante64-HX card**.

### 3.4.8 E-IPA-HX high capacity IP to matrix card

The E-IPA-HX card is a high capacity internet protocol (IP) audio card. It provides up to 64 connections.

The card will offer both IVC ports and FSII IP transceiver support. This can be a combination of up to 64 IP ports and/or FreeSpeak II wireless beltpack connections (according to license).

IVC-32 legacy functionality (V-series panels, Directs, LQ, and Agent-IC) can run at the same time as FSII beltpacks.

The E-IPA-HX card will only run with the latest EHX software (EHX 10.0 and above).

## 3.5 Interface modules

Interface modules convert the 4-wire signals of a central matrix port to other types of signals that communicate with devices such as telephones, camera intercoms, two-way radios, and so on. In this way non-4-wire devices can communicate with the central matrix.

**Note:** The term **central matrix** is used to differentiate the core hardware and software from the connected intercom panels and interfaces. The central matrix itself consists of the matrix hardware (the Eclipse HX-Omega matrix) and the EHX configuration software.

Each interface module has hardware connectors to connect to both the central matrix and the external device that communicates with the central matrix.

Most interface modules connect to the central matrix via shielded CAT-5 cable terminated with RJ-45 connectors.

**Note:** The DIG-2 digital interface module connects to the central matrix via double-shielded 24 AWG conductor category-6 enhanced (CAT-6E) STP cable.

**Note:** The type of cable used to connect the interface module to the non-4-wire device varies with the device. For more information about the operation, installation, and maintenance of an interface module, as well as cabling information, see the specific documentation (user guide / manual) for each interface.

The following interface modules are compatible with the Eclipse HX-Omega matrix:

- **TEL-14** telephone interface module.
- **CCI-22** dual party-line interface module.
- **FOR-22** four-wire interface.
- **GPI-6** general purpose inputs interface module.
- **RLY-6** relay (general-purpose outputs) interface module.
- **AES-6** digital interface module used with V-Series panels fitted with the AES-3 option card. It may also be used with AES-3 compliant third party equipment.
- **DIG-2** digital interface module (transparent to the system, configured in EHX as the type of panel it is connected to). Only used for V-Series panels fitted with the T-Adapter option card and ICSxx T type panels.

## 3.6 EHX configuration software

The EHX configuration software controls the operation of the connected audio devices by sending signals to the circuit cards in the matrix, which then relays the signals to the audio devices.

**Configurations** (the operating parameters of complete system setups) are created and managed in EHX.

Up to four complete system configurations can be stored in the CPU card of the Eclipse HX Omega, for retrieval and activation when required. The external PC that hosts the EHX software can store an almost unlimited number of complete system configurations (the number is only limited by the available memory space on the PC).

You can download the configurations to the Eclipse HX-Omega as required.

EHX configuration software runs on the following versions of Windows:

- Microsoft Windows 7 (32-bit and 64-bit).
- Microsoft Windows 8.1 (32-bit and 64-bit)
- Microsoft Windows 10 (32-bit and 64-bit)
- Microsoft Windows Server 2008 R2 (64-bit)

- Microsoft Windows Server 2012 R2 (64-bit)
- Microsoft Windows Server 2016 (64-bit)

**Note:** Operation on other platforms is no longer supported.

When running EHX on Windows operating systems, the client and server can run on separate machines connected over a network.

You can use EHX to perform a wide range of configuration tasks, including:

- Assigning labels (names) to ports and user panels.
- Creating point-to-point and fixed group (partyline) communications between connected audio devices.
- Enabling, limiting or disabling features of any connected user panel or card.
- Configuring connections between matrices.

**Note:** The above list is not definitive. For more information about the capabilities of EHX, see the ***EHX User Guide***.

The EHX system can be set up to run on a client/server model over a network, allowing the system administrator to control the matrix remotely.

## 3.7 User panels

All intercom panels connect to the central matrix using shielded CAT5 cable terminated with RJ-45 connectors. The shielded CAT5 cable connects to the matrix through the MVX-A16 analog interface.

The following Clear-Com user panels are fully compatible with the Eclipse HX-Omega matrix system:

- V-Series panels, including expansion panels.
- i-Series panels, including expansion panels.

**Note:** For more information about installing, using and maintaining user panels, and connecting user panels to the matrix, see either:

- ***The V-Series Panels Guide.***
- ***The i-Series Panels Guide.***

## 4 Installing the Eclipse HX-Omega

This chapter describes how to install the Eclipse HX-Omega matrix, including the power supplies, connector panels, CPU cards, the port and expansion cards.

It also describes how to connect interface cards, interface modules and intercom (user) panels to the matrix.

**Note:** For an overview of the Eclipse HX-Omega matrix, including cards, interface modules and compatible intercom panels, see **2.1 Further information** in this guide.

### 4.1 Cabling recommendations

Clear-Com recommends the following cabling.

<b>Clear-Com CAT5e/6a cable recommendations</b>	
Category (CAT)	Higher CAT numbers will support a higher bandwidth. Therefore, by using a higher CAT number, you are future proofing your system to some extent.  Example: <ul style="list-style-type: none"> <li>• Cat5: up to 1G</li> <li>• Cat6a: up to 10G.</li> </ul> Use CAT5e or higher.
American Wire Guage (AWG)	The lower the AWG number, the less temperature rise there will be in the cable when using PoE. This is particularly important for bundles. Local building regulations may rule out the use of 26AWG or higher, depending on the installation. Check with your local building regulations.  Use AWG 24 or lower.
Shielded Twisted Pair (STP) or Foiled Twisted Pair (FTP)	Using shielded cable means less problems with interference from other sources. This means that your network will be more robust if you use shielded cables.
Overall Recommendation	Use CAT6a 23 AWG STP cable.

## 4.2 Before you begin the installation

### 4.2.1 Checking the shipment

When the Eclipse HX-Omega is received, inspect the boxes for shipping damage. Report any shipping damage to the carrier.

**Note:** The Eclipse HX distributor is **not** responsible for shipping damage.

Check the packing list and verify that every item on the list has been received. Save all packing materials in the event that any items need to be returned.

### 4.2.2 Unpacking the System

When the Eclipse HX-Omega system is received the circuit cards, power supplies, and rear-connector panels are pre-installed in the matrix chassis. The customer must supply:

- The standard 19-inch rack in which to install the matrix.
- A personal computer to run the EHX configuration software

**Note:** For the minimum and recommended requirements for the PC running the EHX software, see **15.30 Minimum PC requirements (for EHX software)** and **15.31 Recommended PC requirements (for EHX software)**

- Shielded CAT-5 cables (to connect the matrix to panels and interfaces).

### 4.2.3 Reconnecting the CPU Card's backup battery

**Important:** Before the Eclipse HX-Omega is installed, the CPU card's backup battery **must** be reconnected. The matrix will operate if the battery is not reconnected. However, if the matrix is powered down, all run time information (dynamic assignments, crosspoint states and levels) **will be lost**.

**Battery activation and deactivation should be carried out by qualified service personnel.**

The matrix CPU card has a lithium backup battery that powers the CPU memory if the AC electricity fails. This backup battery is shipped disconnected to preserve battery life.



**Observe anti-static procedures.** The CPU card can be damaged by static electricity. Personnel reconnecting the battery should ensure that they ground themselves and all tools before touching cards.

To reconnect the CPU memory's backup battery:

- 1) Locate **CON9** on the centermost, upper portion of the CPU card.

- 2) Locate the three pins under the **CON9** heading. A jumper plug is placed over pins 2 and 3. This is the **OFF** position.
- 3) Lift the jumper plug off the pins, and place it over pins 1 and 2. This is the **ON** position.
- 4) The battery is now powered.

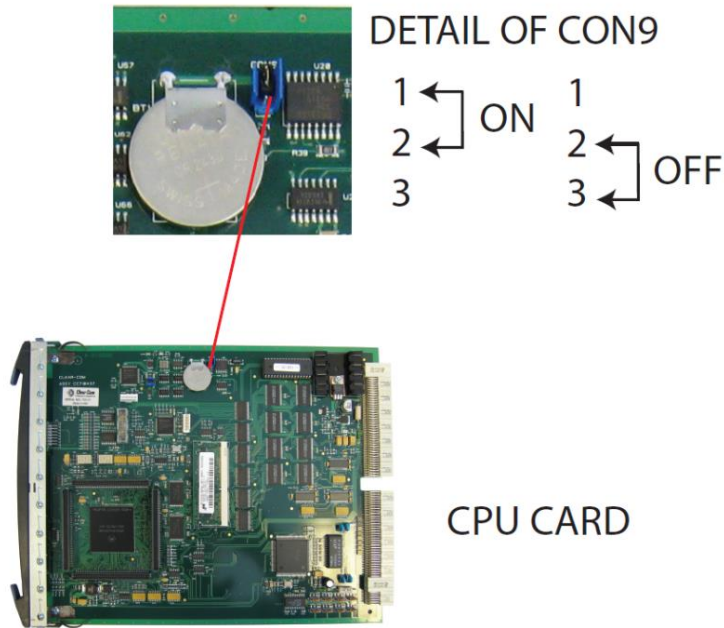

**Figure 4-1: CPU card with detail of CON9 jumper plugs**

Eclipse HX-Omega CPU cards are fitted with a socketed battery which is normally a Renata CR2477N with a capacity of 950mAh and a life of approximately 247 days. These socketed batteries are easily replaced and this operation does not have to be carried out by service personnel.

**Disconnecting the CPU backup battery**

Before performing any service on the CPU card, the backup battery must be disconnected. To do so, place the CON9 jumpers in the OFF position as described in the previous procedure.

Pin	Status
1	On
2	Common
3	Off

**Table 4-1: CON9 Pin configuration**

If the matrix is going to be stored for more than 3 months, the CPU backup battery needs to be temporarily deactivated while the matrix is stored.

To do so, put the CON9 jumper in the OFF position as described above. In order to power up and start operating the matrix, reconnect the CPU backup battery by placing the CON9 jumper in the ON position, as described above.

### Low power warning

If the CPU card is left unpowered for a period of time the batteries for the battery backed up RAM may become discharged. This results in the run time information being lost.

If this state is detected by the CPU card then the CPU card will provide signalization on its **OK LED** in the form of 2 rapid flashes followed by a slow flash of the OK LED. If EHX is logging, then the following message will appear in the log.

### Non Volatile Data is invalid - Please check Battery Voltage

If on successive power downs of the HX-Omega matrix the above state is detected, and the message appears in EHX logs, then it is advisable to check the health of the CPU card on-board battery, which should be nominally at least 2.8V.

The minimum at which the data may remain intact is around 1.5V but normally the battery should be replaced before the voltage drops to this level.



Danger of explosion if battery is incorrectly replaced. Replace only with the same or equivalent type.

Lithium batteries can overheat or explode if they are shorted. When handling the CPU card or a loose battery, **do not** touch any external electrical conductors to the battery's terminals or circuits to which the terminals are connected.

**Note:** When servicing the battery, make sure that the jumper on CON9 is connecting pin 2 (common) to either pin 1 (on) or to pin 2 (off). If the common is left floating, the CPU may behave unpredictably. For example, the microprocessor may reset itself intermittently.

## 4.3 Installing the Eclipse HX-Omega

The following overview gives a summary of the steps required to install an Eclipse HX-Omega matrix. More detailed information on each step is provided in the sections that follow.

To install an Eclipse HX-Omega matrix:

- 1) Remove the Eclipse HX-Omega matrix chassis from its shipping carton.
- 2) Install the Eclipse HX-Omega to the standard 19 inch rack.  
**Note:** **Environmental information:** Leave at least 2 inches (51 mm) of clearance on all sides of the matrix chassis to ensure proper airflow. Do not block ventilation vents.
- 3) Check the position of circuit cards, power supplies, and rear-connector panels. Later sections in this chapter give more information on these items.
- 4) Apply AC power to the unit. The unit has two separate AC power entry connectors for the two separate power supplies in the system.

### 4.3.1 Installing the power supplies

The Eclipse HX-Omega system's DC power supplies run on AC mains power.

Two identical Euro Cassette power supplies are provided to ensure that every matrix will have redundant power (ensuring that the matrix will continue to operate even if one supply output fails).

Each of the power supplies must be connected to a dedicated branch of AC mains power. The matrix will continue to operate even if one of the AC power branches fails.

Clear-Com supplies each matrix with power supplies already installed. When the matrix is installed connect the power supplies to AC mains power using the IEC power connectors on the matrix's rear panel.

A fully equipped Eclipse HX-Omega matrix (for example, 2 CPU cards, 4 E-Que cards and 11 MVX-A16 cards) requires 100 - 240 VAC at 50 - 60 Hz with a maximum dissipation of 300W.

### 4.3.2 Installing the rear connector panels

The rear panel of the matrix is constructed of modular, individually-installable connector panels. Each port or expansion card has a corresponding rear-connector panel:

- Each **MVX-A16** rear connector panel contains 16 RJ-45 connectors.
- **E-FIB** rear cards contain two fiber connectors.
- **E-Que**, **IVC-32** and **LMC-64** rear cards contain 11 RJ-45 connectors.
- **E-MADI64** rear cards contain a MADI fiber connector, MADI input and output coaxial cable connectors, and a coaxial Video / Word clock input.

**Note:** Clear-Com ships each matrix with the required number of rear-connector panels already installed. Blank rear panels fill unused card slots.

To **add** a rear panel to the matrix:

- 1) Remove the desired blank rear panel by loosening the screws and pulling the panel out. The screws are attached and cannot be removed.
- 2) Install the new rear panel by sliding the card into the card's guides at the top and bottom of the Eclipse HX-Omega chassis.
- 3) Tighten all of the screws on the rear panel.

To **remove** a rear panel from the matrix:

- 1) Detach any devices connected to the rear panel's connectors.
- 2) Loosen the screws that hold the rear panel to the matrix. The screws are attached and will not fall off.
- 3) Remove the rear panel by pulling the panel out.

## 4.4 Installing CPU cards

The CPU card's components include CMOS chips which are sensitive to static electricity. Before touching the CPU card touch a grounded metal object, such as any unpainted surface on the matrix, to dissipate static electricity. While handling the CPU card, take care not to bend any of the card's connector pins or component leads.

Before operating the CPU card the card's battery must be reconnected.

**Note:** The CPU card is shipped with a disconnected battery to preserve battery life. For instructions on reconnecting the battery, see **4.2.3 Reconnecting the CPU Card's backup battery**.

The DIP switches on the CPU card should be checked before installation to ensure they are correctly configured. The CPU card switch settings for normal operation (watchdog enabled) are shown in **Figure 4-2** below.

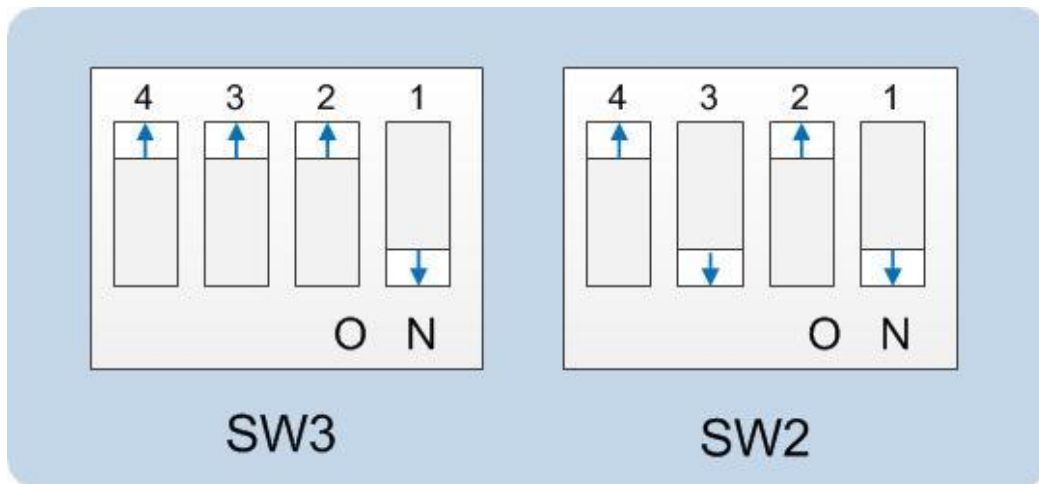

**Figure 4-2: CPU card DIP switches set for normal (watchdog enabled) operation**

**Note:** Store spare CPU cards in unused slots in the matrix (but do **not** plug them in fully) or in electrically insulated packaging such as anti-static heavy duty plastic bags.

To **insert** a CPU card in the matrix:

- 1) Carefully place the card in the appropriate slot. Make sure the card is aligned with the top and bottom precision guides.
- 2) When the card has almost reached the backplane connectors, open the two ejectors, allowing them to clear the edges of the matrix. Gently insert the card further until it touches the backplane connector guides.
- 3) Gently close both ejector tabs at the same time, which will propel the card into the backplane connectors.

To **remove** a CPU card from the matrix:

- 1) Hold the card in place in the matrix.
- 2) There are two card ejector tabs, located at the top and bottom of the CPU card. Open the two ejector tabs at the same time until the card unseats from its backplane connectors.
- 3) Pull the card out of the matrix.

#### 4.4.1 Hot patching CPU cards

The CPU cards (front and rear cards) are **hot patchable** and **self initializing**.

When the matrix is fitted with two CPU cards, a faulty CPU card can be removed and replaced while the system is powered because the second CPU card will automatically begin operating when the first card is removed.

It is advisable to replace CPUs in maintenance down times.

### 4.4.2 Checking the CPU card installation

The CPU card's operating status can be checked by looking at the lights on the front of the card.

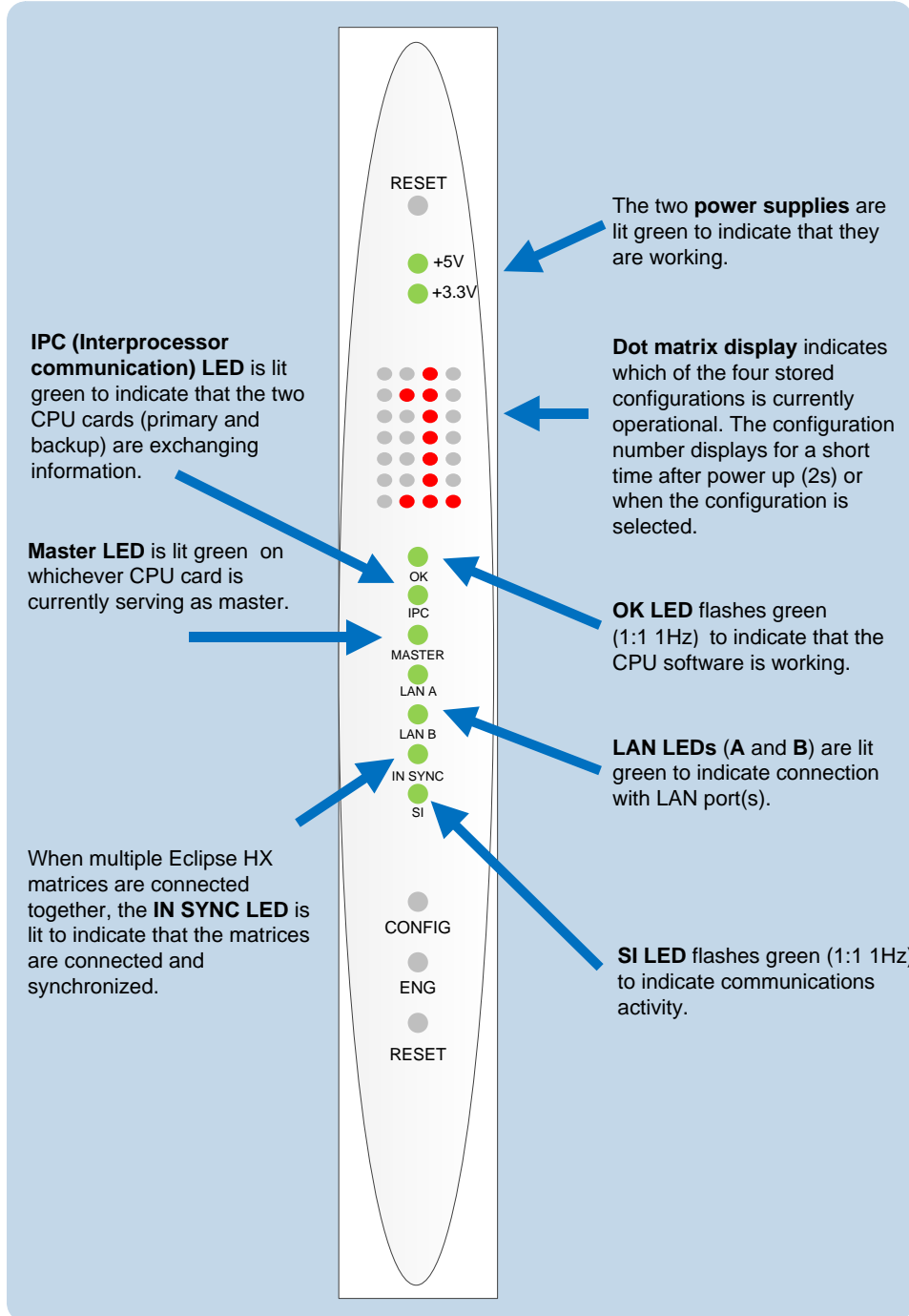

Figure 4-3: CPU card lights

**Note:** Once the CPU card has initialized, you can use the **Eng** button (press and release) to request matrix information (such as the software version and the current IP address).

For more detailed information about the CPU card lights and controls, see **5.5 CPU card lights and controls**.

## 4.5 Installing interface cards

**Note:** Always install the rear card in an interface card set before the front card.

To **install** an interface card:

- 1) Carefully place the card in the appropriate slot. Make sure the card is aligned with the top and bottom precision guides.
- 2) Push the card toward the backplane connectors.
- 3) When the card has almost reached the backplane connectors, open the two ejector tabs, allowing them to clear the edges of the matrix. Gently insert the card further until it touches the backplane connector guides.
- 4) Gently close both ejector tabs at the same time, to propel the card into the backplane connectors.

To **remove** an interface card from the matrix:

- 1) Hold the card in place in the matrix.
- 2) The two card ejector tabs are located at the top and bottom of the card. To remove a card, open the two ejector tabs at the same time until the card unseats from its backplane connectors.
- 3) Pull the card out of the matrix.

### 4.5.1 Combining interface cards in the matrix

The Eclipse can allocate up to 496 audio ports in total. However, the number of ports that you actually use will depend on the combination of interface cards you fit to the matrix.

An **MVX-A16** card uses 16 audio ports.

An **E-MADI64** card is configured in EHX to use either 16, 32, 56 or 64 audio ports.

An **IVC-32** card uses 32 audio ports from the total.

You could fit a maximum contain a maximum of 15 MVX-A16 cards which would fill the matrix, but would only use 240 ports from the possible 496 ports available:

**15 MVX-A16 cards \* 16 ports = 240**

More ports can be utilized on the Eclipse HX-Omega by using higher capacity interface cards, such as the E-MADI64 card.

**(5 E-MADI64 cards \* 64 ports) + (10 MVX-A16 cards \* 16 ports) = 480**

**Note:** A total of four E-Que, IVC-32 or LMC-64 interface cards may be fitted to an Eclipse HX-Omega unless the matrix is fitted with a Power-One PSU. If the matrix has a Power-One PSU, up to six E-Que, IVC-32 or LMC-64 cards may be fitted with the following condition:

- You can only have four wireless E-Que cards
- You can only have four E-Que cards with EM signaling enabled

Up to 6 IVC-32 cards could be installed, using 128 audio ports. This would allow 11 more MVX-A16 cards to be added:

**(6 IVC-32 cards \* 32 ports) + (9 MVX-A16 cards \* 16 ports) = 336**

**LMC-64 cards** take a port per meter. LMC-64 cards are configured in EHX to 16, 32, 48 or 64 audio meters and the same numbers of ports are allocated at that time.

When an audio level meter is configured using Production Maestro Pro one of the ports allocated to the LMC-64 card is used. If the same audio level meter is being used by more than one Production Maestro Pro client this does not increase the port usage as the audio level data is broadcast.

**E-FIB** cards use a port per channel. E-FIB cards can be configured to use between 16 and 192 ports.

**E-Que** wireless cards (if not directly connected) use six ports per antenna.

**E-Que** cards have 60 ports in E1 mode or 48 ports in T1 mode.

## Recommendation

Clear-Com recommends fitting E-FIB cards on in ports 14 or 15 of the matrix.

**Note:** Comfort tones also use 3 ports which normally default to using the top of the physical port range. If required the comfort tones can be redirected to ports above 496 in **System Preferences** (for more information, see your *EHX documentation*).

## 4.5.2 Static sensitivity



**Observe anti-static procedures.** Devices can be damaged by static electricity. Personnel should ensure that they ground themselves and all tools before touching cards.

An interface card's components include CMOS chips that are sensitive to static electricity. Before touching a card first touch a grounded metal object, such as any unpainted surface on the matrix, to dissipate static electricity. When handling a card, be careful not to bend any of the card's connector pins or component leads.

Store spare cards in electrically insulated packaging such as anti-static heavy duty plastic bags or in unused port card slots (though **not** fully seated) in the matrix.

## 4.5.3 Hot patching

Interface cards are **hot patchable** and **self initializing**, meaning that a faulty card can be removed and replaced while the system is powered. This has no effect on any part of the system's operation, except the MVX-A16 card's assigned sixteen ports.

Communication with a card's connected devices will be interrupted when that card is removed from the matrix. When the card is replaced, communication is restored.

## 4.5.4 Configuration

When an interface card is physically installed, its ports must be assigned functions from the EHX configuration software (see your EHX documentation).

## 4.5.5 Checking MVX-A16 analog port card installation

The following lights indicate that an MVX-A16 card has been properly installed in the matrix:

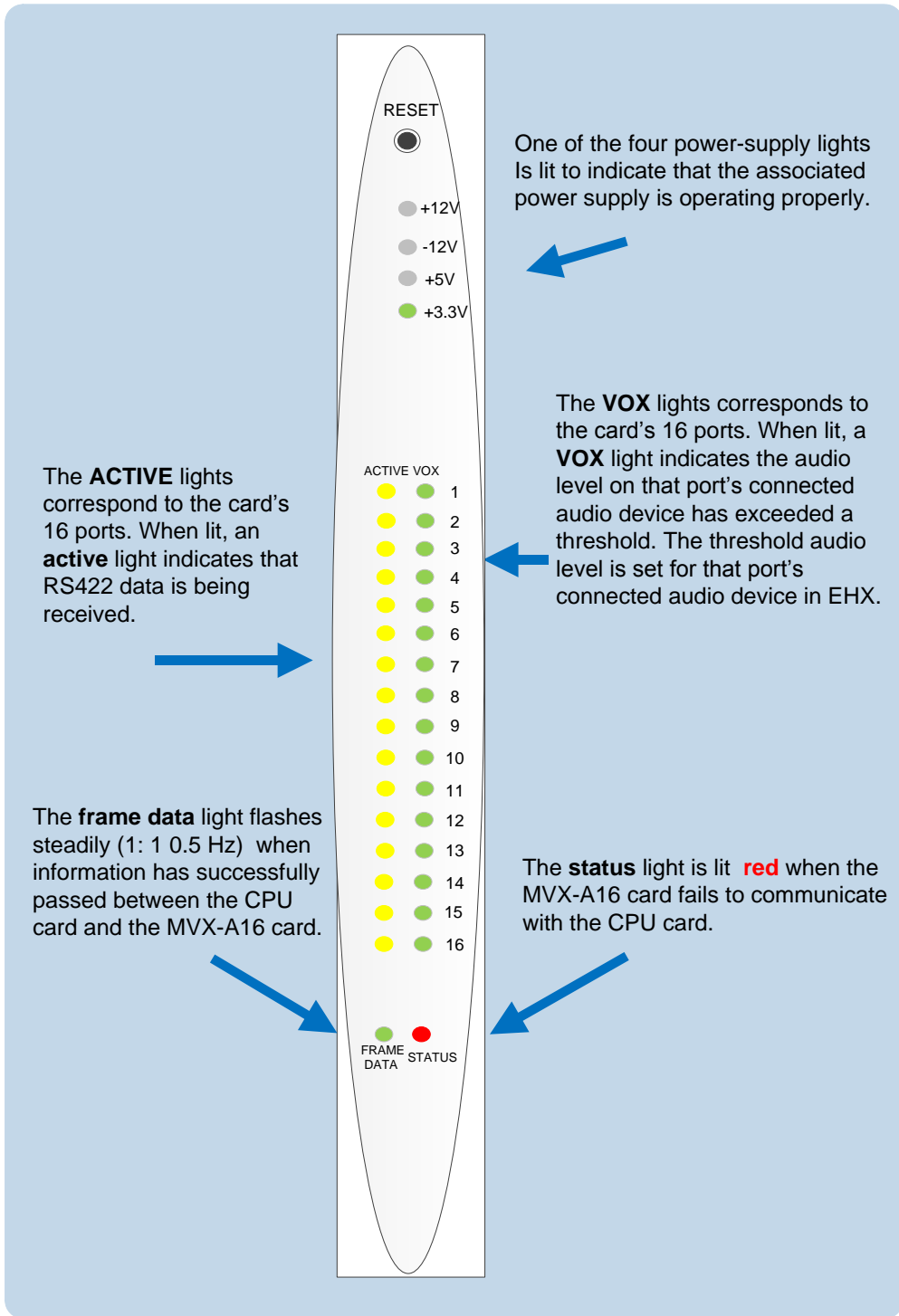

Figure 4-4: MVX-A16 card lights

**Note:** For more detailed information about the MVX-A16 front panel controls and lights, see **5.6 Analog port card (MVX-A16) front-panel lights and controls.**

## 4.5.6 Slot numbering

Each MVX-A16 interface card has circuitry to support 16 analog ports. A grid printed on the matrix's rear panel gives the numbering scheme for the analog ports.

## 4.6 Wiring audio devices to the matrix

An external four-wire audio device can be directly connected to a port connector through the four audio pins. If there is excessive noise on the lines between the device and the matrix, the device may be electronically unbalanced with the rest of the system. The device must be isolated with external isolation transformers.

The **CALL SEND** output can be connected to the **CALL REC** input to tell the system software that this is a directly connected port.

EHX allows the changing of the audio output reference level between **-24, -21, -18, -15, -12, -9, -6, -3, 0, +3, +6, +9, +12** and **+14 dB**.

With a **+12dB** output reference level, it is possible to drive a **200 to 400 Ohm** headset directly with a port output for such uses as direct IFB feed.

The EHX configuration software allows the changing of the audio input reference level between **-12, -9, -6, -3, 0, +3, +6, +9, +11 dB**.

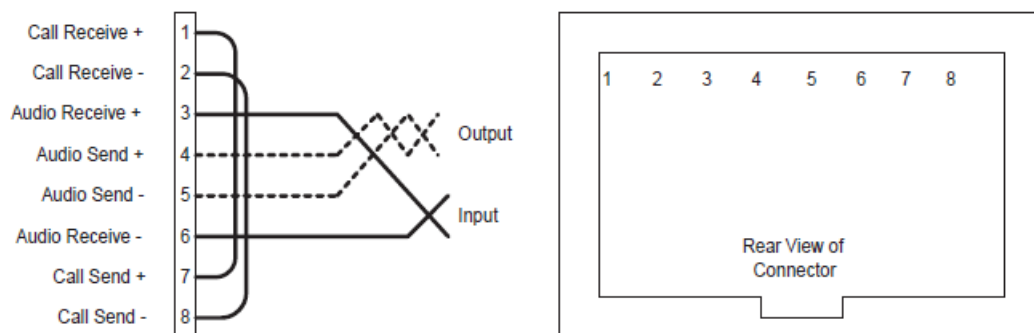

**Figure 4-5: Direct matrix port connection**

Shielded cable should be used.

**Note:** The *Eclipse HX Installation Guide* gives complete details about wiring audio devices to the matrix. The installation manual also discusses RJ-45 cables and other types of cable required for system installation.

## 4.7 Wiring panels to the matrix

Eclipse HX uses a 4-pair (analog) or single-pair (digital) wiring scheme between the matrix and panels. All Eclipse HX panels have built-in RJ-45 connectors.

### 4.7.1 4-Pair analog

Four-pair analog wiring is performed with shielded CAT5 RJ-45 cable:

Pair	Description
<b>Pair 1</b>	Transmits analog audio from the matrix to the panel.
<b>Pair 2</b>	Transmits digital data from the panel back to the matrix.
<b>Pair 3</b>	Transmits audio from the panel to the matrix.
<b>Pair 4</b>	Transmits digital data from the matrix back to the panel.

Table 4-2: 4-Pair analog wiring

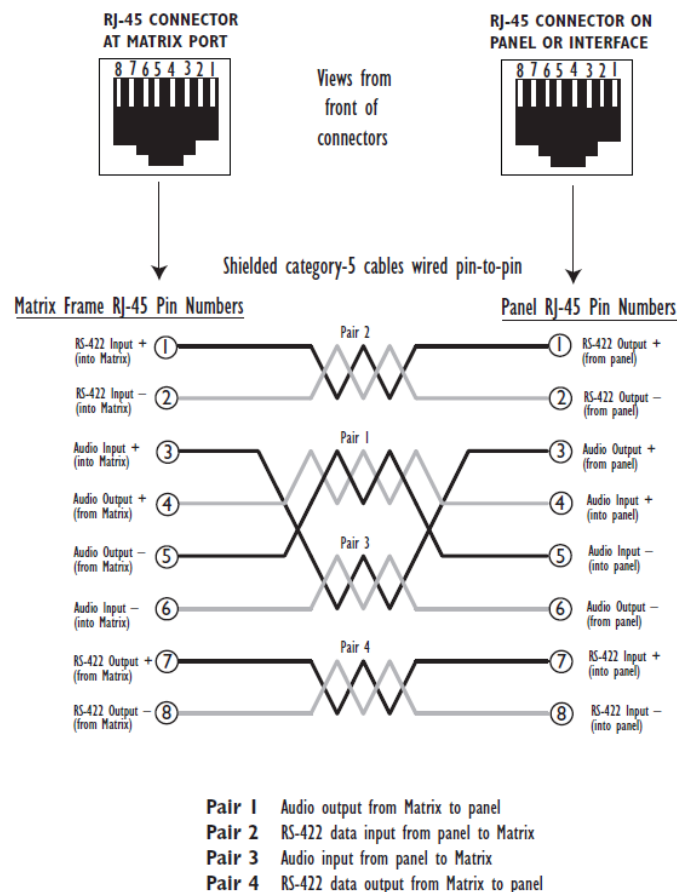

Figure 4-6: Wiring the matrix to an analog panel using RJ-45

### 4.7.2 Single-pair digital

Single-pair digital wiring is accomplished with double-shielded 24 AWG conductor CAT-6E enhanced STP cable.

**Pair 1** transmits and receives multiplexed digital and analog between the matrix and the panel.

Ensure that the **Select** switch on the rear of the panel is in the correct position for the intended use.

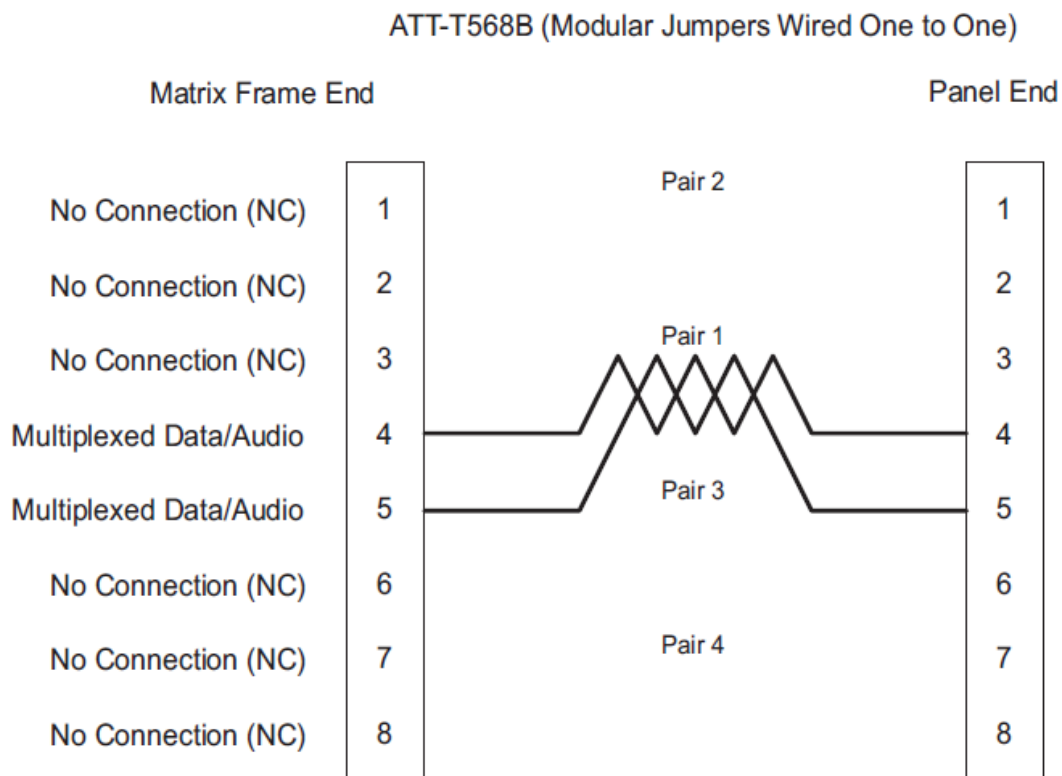

**Figure 4-7: Wiring the matrix to a digital panel using RJ-45**

**Note:** The above wiring diagram refers to **DIG-2 only**.

### 4.8 Wiring CPU card interfaces

The CPU card holds the circuitry for connecting to, and communicating with, the following interfaces:

- An external personal computer.
- Alarm inputs and outputs.
- Eight general purpose inputs (GPIs).

- Eight general purpose outputs (GPOs or relays).
- Two separate local area network (LAN) connections for Ethernet-based communication with a network.
- An external GPI/RLY interface.

### 4.8.1 CPU card interface connectors

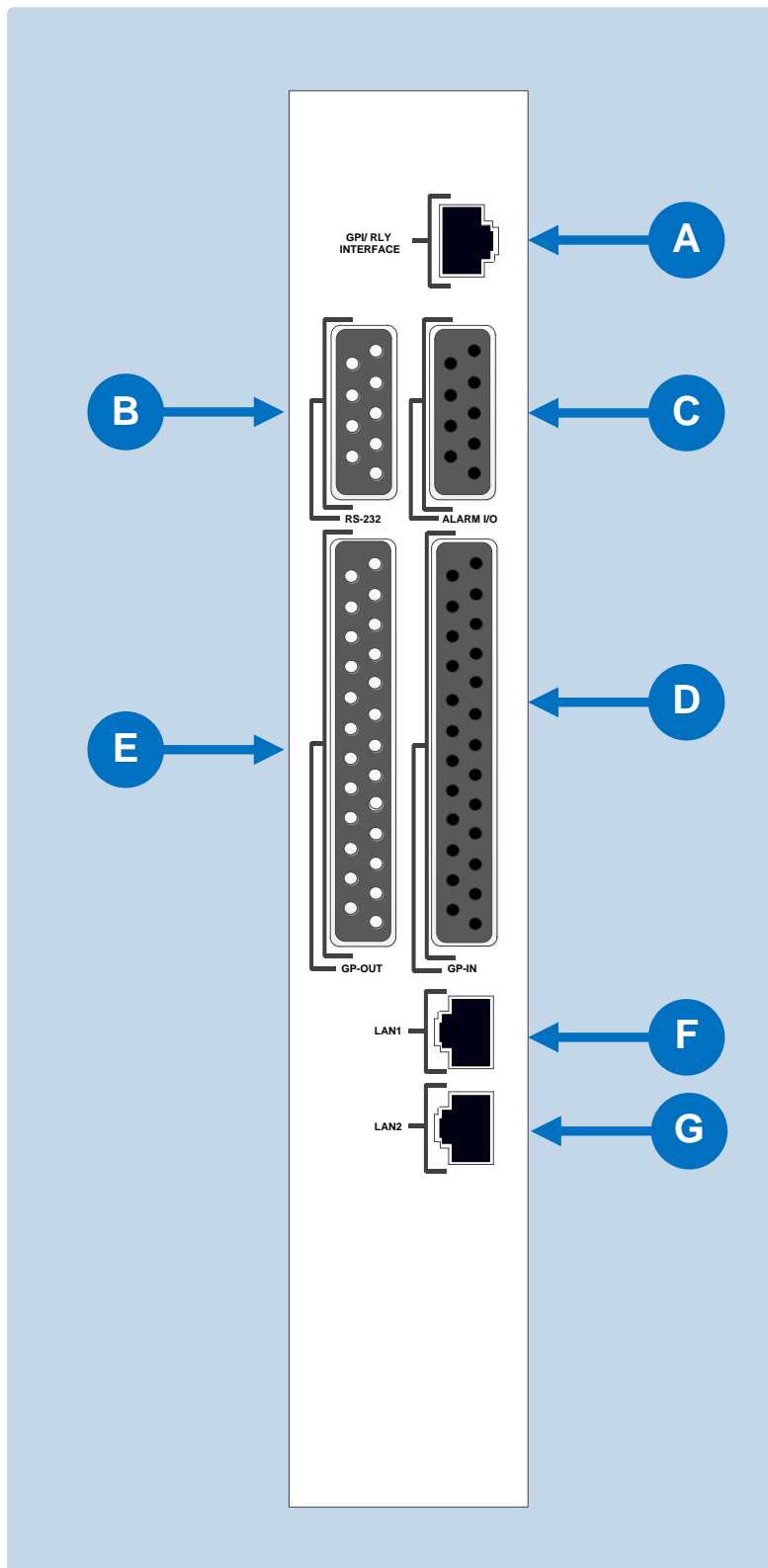
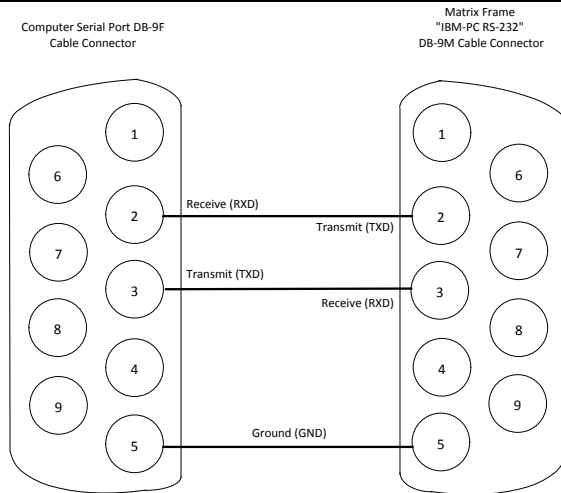
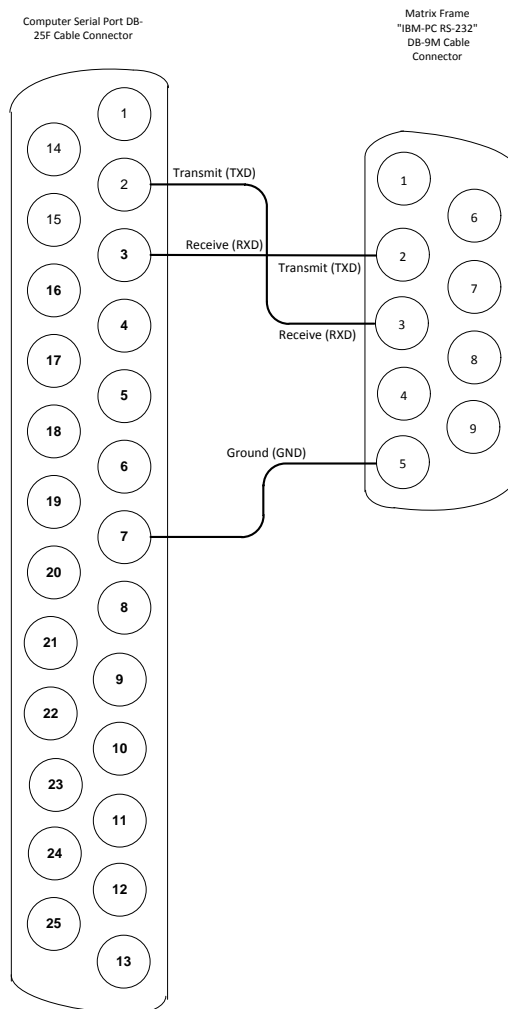

Figure 4-8: CPU card interface connectors

Key to Figure 9: CPU card interface connectors	
Feature	Description
<b>A</b>	<p><b>GPI/RLY Interface Connector</b></p> <p>The RJ-45 socket labeled <b>GPI/RLY Interface</b> connects the CPU card to a GPI-6 or RLY-6 card. The GPI-6 provides six general-purpose opto-isolated logic inputs. The RLY-6 card provides six single-pole, double-throw relay outputs.</p> <p>Both card types mount in either an IMF-3 interface frame or an IMF-102 interface frame. Up to ten GPI-6 or RLY-6 cards can be operated at one time from the matrix by daisy-chaining the cards together. Each card has an IN and an OUT connector for this purpose.</p> <p>The RLY-6 and GPI-6 cards connect to the GPI/RLY interface connector using shielded category-5 cable. For more information about the GPI-6 and RLY-6 cards, consult their respective manuals in the Eclipse HX documentation set.</p> <p><i>Note: If this port is used a ferrite core must be added to the socket end of each cable. A suitable ferrite core is <b>Würth Elektronik part: 74271132</b>.</i></p> <p><i>A shielded cable should be used.</i></p> <p>For wiring pinout information for GPI/RLY interfaces, see:</p> <ul style="list-style-type: none"> <li>• The <b>Relay Interface Module (RLY-6) Instruction Manual</b>.</li> <li>• The <b>General Purpose Inputs (GPI-6) Instruction Manual</b>.</li> </ul>
<b>B</b>	<p><b>RS-232 DB-9 Connector</b></p> <p>The DB-9 connector labeled RS-232 connects the Eclipse HX-Omega matrix to an external computer. To connect a computer to the matrix, run cable from the RS-232 connector to the PC's serial port. The maximum recommended length of the cable is approximately 10 feet (3 meters). A computer has either a 9-pin serial port or a 25-pin serial port.</p>



**Figure 4-9: Wiring the matrix DB-9M to the PC DB-9F**



**Figure 4-10: PC DB-25F connector to matrix DB-9M**



### Alarm I/O Connector

The DB-9F connector labeled **Alarm I/O** connects the matrix to a control circuit for an external alarm, such as a light or bell. The external alarm activates whenever an alarm condition is detected in the matrix.

The following conditions trigger an alarm:

- If any of the voltages produced by the first power supply unit fall below their normal levels.
- If any of the voltages produced by the second power supply unit fall below their normal levels.
- If an external alarm circuit or other logic circuit connected to the power supply is activated.
- If either of the two power-supply unit fans stop operating.
- If software on a master CPU card generates an alarm.

An alarm condition activates the relay contacts connected to **pins 4, 5, and 9**. These contacts are "dry", (no voltage is supplied to them by the matrix) and are rated at **1 A at 24 VDC**. They should not be used for AC mains line current.

Pins are provided for adding an additional alarm source to the matrix's alarm system. **Pin 6** is an alarm input to the Eclipse HX-Omega matrix. It is connected to the input of a 3.3 V logic device. A logic high on this input will cause the Eclipse HX-Omega matrix to detect an alarm condition. A logic low or an open circuit will cause the Eclipse HX-Omega matrix to detect no alarm condition.

**Pin 1** is a voltage source out of the Eclipse HX-Omega matrix. It is connected through a 10Kohm pull-up resistor to the **+5 V** supply rail inside the Eclipse HX-Omega matrix.

A contact closure placed across **pins 1 and 6** will also cause an alarm condition.

**Tip:** *The alarm outputs of the PSU-101 power supply could be wired directly to these pins allowing the CPU card to report PSU failures also.*

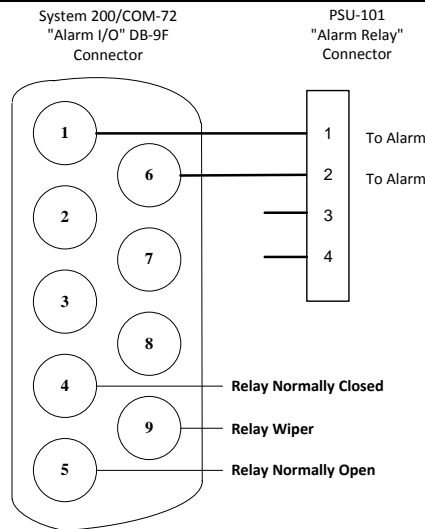

**Figure 4-11: Wiring the Alarm I/O DB-9F to the Alarm Relay connector**

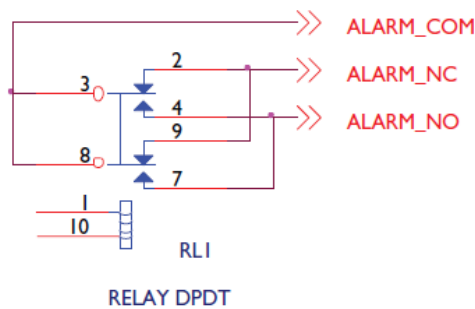

**Figure 4-12: Double-pole double-throw alarm relay**

**D**

**General-Purpose Outputs Connector (GP OUT)**

A GPO can be programmed to mute a speaker, to turn on an applause light, to turn on a door lock, or to perform a variety of other functions. For example, to get the attention of a panel operator working in a high-noise environment such as a control booth, a relay can be programmed to switch on a light at the operator panel each time an incoming call is received, to ensure that the call is not missed.

*Note: If the **GP-OUT** port is used on an Eclipse HX-Omega matrix fitted with XP power supplies (part 740101Z) the following filter must be fitted between the PROC-RCC socket and the cable:*

**CINCH FA-25PS/1-LF 25W D-type in-line 1000pF filter  
(UK supplier: Farnell 111-4108)**

If the matrix is equipped with Power-One power supplies (part 720379Z) this filter **must not be fitted**. If this filter is already fitted to matrix and the power supplies are changed to Power-One units the filter must be removed before the matrix is powered up.

The DB-25 connector labeled **GP OUT** connects the matrix to eight double-pole double-throw (DPDT) relays with contact ratings of 30 VDC at 1A.

Each general-purpose output has a relay inside the matrix. When a general-purpose output is inactive, the associated **common** pin on the **GP OUT** connector will be shorted to the relevant **normally closed** pin. When a general-purpose output becomes active, the short between the **common** pin is broken and a new connection is made between the **common** pin and the **normally open** pin.

DB-25 Male Connector

PIN	DESCRIPTION
1	RELAY 1 Common
2	RELAY 1 Normally Closed
3	RELAY 1 Normally Open
4	RELAY 2 Common
5	RELAY 2 Normally Closed
6	RELAY 2 Normally Open
7	RELAY 3 Common
8	RELAY 3 Normally Closed
9	RELAY 3 Normally Open
10	RELAY 4 Common
11	RELAY 4 Normally Closed
12	RELAY 4 Normally Open
13	GROUND
14	RELAY 5 Common
15	RELAY 5 Normally Closed
16	RELAY 5 Normally Open
17	RELAY 6 Common
18	RELAY 6 Normally Closed
19	RELAY 6 Normally Open
20	RELAY 7 Common
21	RELAY 7 Normally Closed
22	RELAY 7 Normally Open
23	RELAY 8 Common
24	RELAY 8 Normally Closed
25	RELAY 8 Normally Open

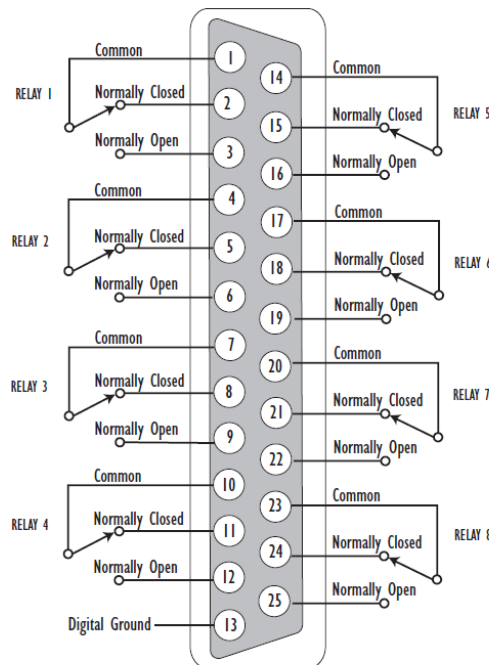

30 VDC at 1 Ampere

Figure 4-13: Pin configuration of the GPO connector



**General-Purpose Inputs Connector (GP IN)**

The DB-25 connector labeled **GP IN** connects the matrix to eight local general-purpose inputs (GPIs).

An external device such as a foot switch, a panel-mounted switch or the logic output of some other device can be connected to the **GP IN** connector. When the external device is

activated, it sends a control signal into the matrix to perform one of several preset functions, such as turning a user panel's microphone on or off, muting a microphone's output, or turning a panel's speaker off. The function to perform and the panel upon which it is performed is configured using EHX.

A shielded cable should be used.

The general-purpose inputs operate in one of two modes: the **opto-isolated** mode or the non-isolated mode.

The opto-isolated mode requires the externally connected equipment to provide the current to power the general-purpose input. The non-isolated mode does not require that the externally connected equipment powers the general-purpose input. The current is supplied by a voltage output on the **GP IN** connector.

To select a mode, move the J1 jumper on the CPU rear card to one of two positions. The J1 jumper is located on the inner-matrix side of the DB-25 connector.

For **opto-isolated mode**, fit the J1 jumper across **pins 1 and 2**.

For **non-isolated mode**, fit the J1 jumper across **pins 2 and 3**.

It is recommended that the connector is set to the fully opto-isolated mode.

### Opto-isolated mode

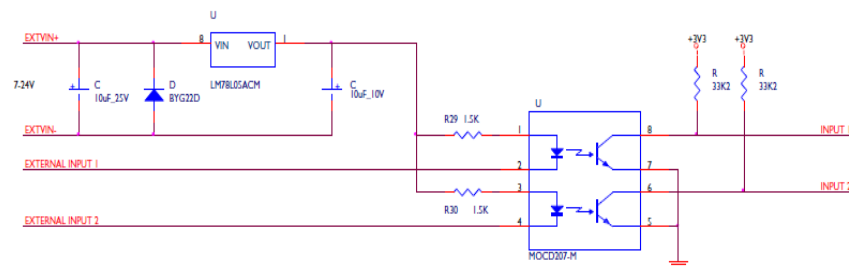

**Figure 4-14: Opto-isolated mode**

In this mode, a DC voltage of between 7 and 24 volts is required at the EXTVIN+ pin with relation to the EXTVIN- pin. To cause an input to detect an active signal, current must flow from the relevant input pin.

The external device should draw no current to cause an inactive input and at least 5 mA to cause an active input. The opto-isolator drive line contains a 1.5 kOhm resistor to limit the current through the opto-isolator. Therefore the input pins can

be connected directly to the EXTVIN- level to cause an active input.

The voltage level at the external input pin should not be allowed to go below EXTVIN- or above +6 V with respect to EXTVIN-.

**Non-isolated mode**

To cause an input to detect an active signal in non-isolated mode, the current must flow from the relevant input pin.

The external device should draw no current to cause an inactive input and at least 5 mA to cause an active input. The opto-isolator drive line contains a 1.5 kOhm resistor to limit the current through the opto-isolator.

Therefore the input pins can be connected directly to a ground pin to cause an active input.

The voltage level at the external input pin should not be allowed to go below ground or above +6 V with respect to ground.

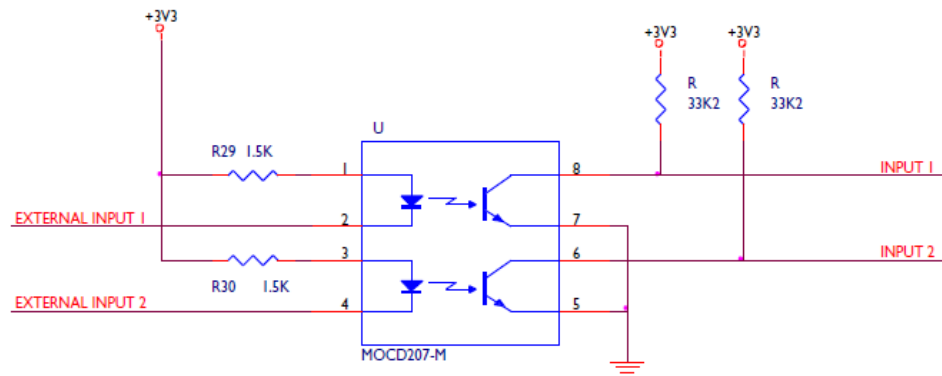

**Figure 4-15: Non-isolated mode**

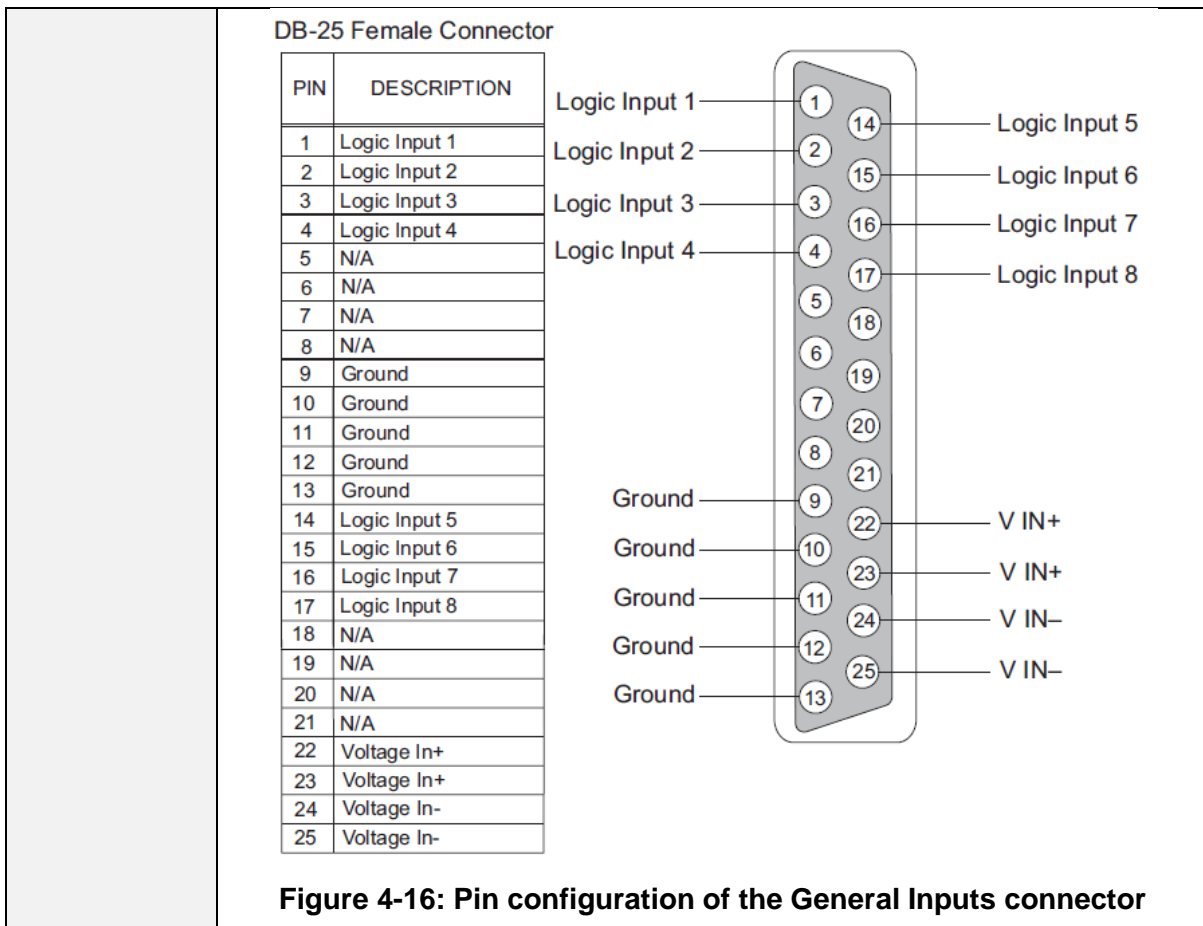

Figure 4-16: Pin configuration of the General Inputs connector

**F**

**Local Area Network connector (LAN1)**

The **LAN1** and **LAN2** connectors have standard Ethernet pin assignments. See **G** below for pin assignments.

The RJ-45 socket labeled **LAN 1** connects a local area network (LAN) to the CPU card through a standard Ethernet connection. The **green** LED indicates the port is connected and the amber LED indicates activity.

*Note: If this port is used a ferrite core must be added to the socket end of each cable. A suitable ferrite core is **Würth Elektronik part: 74271132**.  
A shielded CAT-5 cable should be used.*

**G**

**Local Area Network connector (LAN2)**

The **LAN1** and **LAN2** connectors have standard Ethernet pin assignments.

LAN1 and LAN2  
Ethernet RJ-45 Connectors

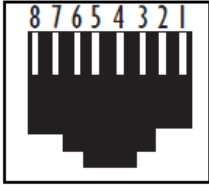

PIN	FUNCTION
1	Transmit data +
2	Transmit data –
3	Receive data +
4	Unused
5	Unused
6	Receive data –
7	Unused
8	Unused

**Figure 4-17: LAN1 and LAN2 pin assignments**

The **green** LED indicates the port is connected and the **amber** LED indicates activity.

Note:

*If this port is used a ferrite core must be added to the socket end of each cable. A suitable ferrite core is **Würth Elektronik part: 74271132**.*

*A shielded CAT5 cable should be used.*

**Table 4-3: Key to CPU card interface connectors**

## 4.9 DSE1/T1 Matrix to Matrix crossover cable connections

For E1 and T1 direct matrix to matrix connections the CAT5 crossover cables should be wired.

Matrix 1 Pin	Description	Matrix 2 Pin
<b>1</b>	To	<b>4</b>
<b>2</b>	To	<b>5</b>

<b>3</b>	Not connected	<b>3</b>
<b>4</b>	To	<b>1</b>
<b>5</b>	To	<b>2</b>
<b>6</b>	Not connected	<b>6</b>
<b>7</b>	Not connected	<b>7</b>
<b>8</b>	Not connected	<b>8</b>

Table 4-4: E1/T1 Crossover cable

## 4.10 E1/T1 Matrix to Matrix straight cable connections

E1/T1 straight cables may be used to connect E1 or T1 ports to E1 or T1 networks or third party equipment.

<b>Matrix 1 Pin</b>	<b>Description</b>	<b>Matrix 2 Pin</b>
<b>1</b>	To	<b>1</b>
<b>2</b>	To	<b>2</b>
<b>3</b>	Not connected	<b>3</b>
<b>4</b>	To	<b>4</b>
<b>5</b>	To	<b>5</b>
<b>6</b>	Not connected	<b>6</b>
<b>7</b>	Not connected	<b>7</b>
<b>8</b>	Not connected	<b>8</b>

Table 4-5: E1/T1 Straight cable

## 4.11 E1 to FreeSpeak® / CellCom® / FreeSpeak II™ antenna straight cable connection

Straight CAT-5 cables are used to connect an E-Que card to a FreeSpeak / CellCom / FreeSpeak II antenna or splitter.

The E1 pinout for connecting an antenna or splitter is shown in **Table 4-6: E1 pinout for connecting a FreeSpeak / CellCom / FreeSpeak II antenna or splitter.**

Cable wiring is shown in **Table 4-7: E1 to FreeSpeak / CellCom / FreeSpeak II antenna or splitter straight cable connection.**

Pin	Description
<b>1</b>	Tx+
<b>2</b>	Tx-
<b>3*</b>	DECTSYNC+
<b>4</b>	Rx+
<b>5</b>	Rx-
<b>6*</b>	DECTSYNC-
<b>7*</b>	GND
<b>8*</b>	12V

**Table 4-6: E1 pinout for connecting a FreeSpeak / CellCom / FreeSpeak II antenna or splitter**

Matrix 1 Pin	Description	Matrix 2 Pin
<b>1</b>	To	<b>1</b>
<b>2</b>	To	<b>2</b>
<b>3</b>	Not connected	<b>3</b>
<b>4</b>	To	<b>4</b>
<b>5</b>	To	<b>5</b>
<b>6</b>	Not connected	<b>6</b>
<b>7</b>	Not connected	<b>7</b>
<b>8</b>	Not connected	<b>8</b>

**Table 4-7: E1 to FreeSpeak / CellCom / FreeSpeak II antenna or splitter straight cable connection**

## 5 Using the Eclipse HX-Omega

---

This chapter describes how to use (operate) the Eclipse HX-Omega matrix and its circuit cards.

The Eclipse HX-Omega matrix chassis houses the circuit cards, power supplies, and connectors that form the central hardware of the system.

Various types of Eclipse HX-Omega circuit cards perform unique functions:

- CPU cards control overall system operation.
- MVX-A16 interface cards control the operation of connected user panels, interface modules, and other intercom devices.
- A range of other interface cards enable communication with wireless equipment, fiber optic links and IP networks.

Two Euro Cassette power supplies provide fail-safe redundancy in the event of a component failure or an AC circuit outage. Front-panel lights give information about the condition of the power supplies, allowing the system operator to take preventative corrective action.

Each MVX-A16 interface connects to an individual panel on the back of the Eclipse HX-Omega matrix. This panel holds the RJ-45 sockets for connecting to intercom panels and interface modules.

The Eclipse HX-Omega matrix is completely modular, allowing cards, power supplies, and connector panels to be added or removed to meet operational needs.

**Note:** For an overview of the Eclipse HX-Omega matrix, see **3 Overview**.

### 5.1 Creating and storing system configurations

A **configuration** is a complete set of operating parameters for the system which includes talk and listen paths for each connected intercom device. Depending on the interface cards and modules installed, the configuration can include more complex features such as paging, call signaling, interrupt foldback (IFB), ISO, groups, automatic DTMF dialing, and routing.

When an external computer is connected to the matrix, you can:

- Retrieve the current configuration information stored in the CPU microprocessor's memory and display the configuration in EHX.

- Apply the current configuration, modify it, or create a new configuration in EHX.

If you create more than one configuration, you can store the unused configurations on the computer's hard disk or on CD-ROM for later use.

**Note:** The CPU card in the Eclipse Omega stores up to four complete configurations. You can apply a configuration directly from the CPU card or from the connected PC.

## 5.2 Setting the default IP Address

To reset the CPU LAN ports to their default IP addresses, press and hold the **ENG** and **FULL RESET** buttons on the CPU front card until the card resets.

**Note:** Do **not** release the **ENG** and **FULL RESET** buttons until the CPU card LED panel shows either an **A** or a **B**.

The **LAN1** Ethernet port is reset to the factory default address of 169.254.0.100 and the second Ethernet port to the 0.0.0.0 (blank) address.

The LAN1 reverts to a link local address of 169.254.0.100 only after trying and failing to acquire an IP address from the network at startup.

The LAN1 defaults to the DHCP mode of operation. This mode of operation is **not** to be used once the matrix is operational as it delays the start-up of the matrix following any reset.

## 5.3 Using the CPU card Ethernet ports

The CPU card Ethernet ports are normally connected to a LAN and used to communicate with clients such as EHX and Production Maestro. The Ethernet port functionality depends on the IP address setup.

If an IP address of 0.0.0.0 is configured on the second Ethernet port, it will not be used for Tx or Rx. This is the default setup if the default IP address is set as described above.

All matrix to matrix traffic is sent out on both Ethernet ports. This applies to both directed and broadcast packets. All matrix to matrix traffic is also received on both Ethernet ports. If the traffic is transaction related, the second (duplicate) message received is not consumed, but simply dropped.

The matrices listen for client connections on both Ethernet ports. Once the connection is made it is added to the list of connections to service. Broadcast type Tx data is duplicated out on each connection (for example, HCI connection to the matrix from third party applications).

The EHX Server makes a connection on either the main or backup Ethernet port of each system in the linked set. If both are up, this will default to the primary port. In the event that connection is lost to the currently active port on a matrix the EHX server will swap over to using the other Ethernet port. If this connection is lost only on one matrix in a linked set, the others will not be affected.

### 5.3.1 Configuration restrictions for Ethernet ports

The network ID on the first Ethernet port must be different to that of the second port.

The network ID is defined by the IP address and the network mask for the port. For example a network address of 172.16.2.1 and a mask of 255.255.0.0 gives a network ID of 172.16. Therefore in this scheme the second port could not have an IP address, starting with 172.16.

If the network mask is extended to 255.255.255.0 the network ID becomes 172.16.2 so the second port could have an address of 172.16.3.1 and a mask of 255.255.255.0 giving a network ID of 172.16.3 for the second port.

If both Ethernet ports are set up with the same network ID this condition results in data loss on one or both of the Ethernet ports.

**Note:** Ethernet redundancy and the use of a default gateway is **not** supported. An IP address and gateway combination on an Ethernet port means that all Tx traffic to any address is possible on the port. Traffic that actually matches the other Ethernet port can therefore be sent out on the **wrong port**.

## 5.4 CPU card fail-safes

The CPU card's non-volatile memory stores all information about the current operating configuration and the three additional configurations, allowing the system to restore itself automatically after:

- A power failure.
- The replacement of a port card.
- The replacement of a panel.

An Eclipse HX-Omega system operates with either one or two CPU cards.

When a second card is installed, that card stores the four configurations in its RAM as a backup to the main card. If the main card is removed or becomes non-operational for any reason, the system will automatically switch to the second card as backup.

## 5.5 CPU card lights and controls

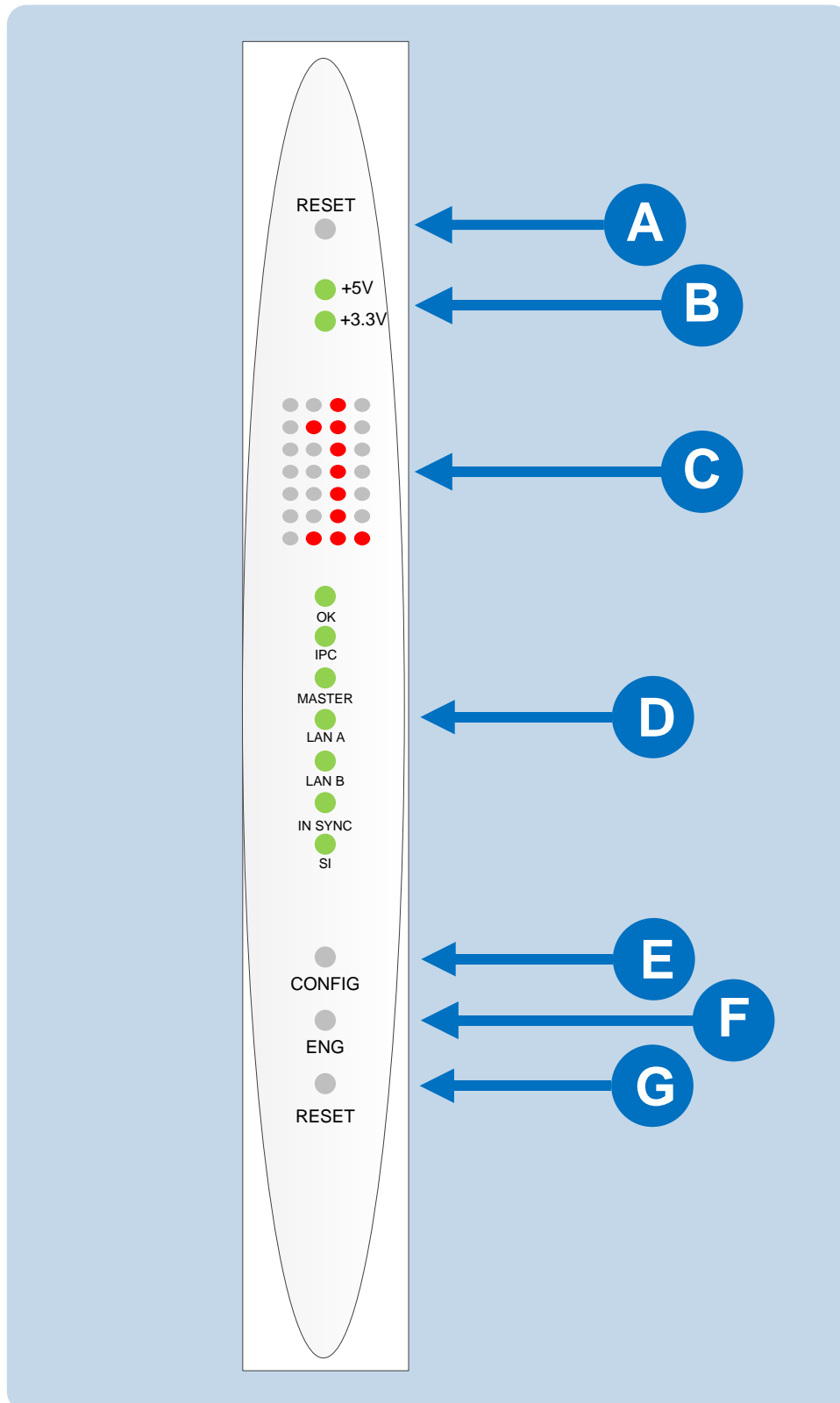





Figure 5-1: CPU card lights and controls

Key to Figure 18: CPU card lights and controls	
Feature	Description
	<p><b>RESET button</b></p> <p>Pressing the <b>RESET</b> button causes the CPU card to stop its current activity and to restart. The same configuration that was active before the system was reset will be active after the system was reset.</p> <p>During the reset, configuration information reloads to the card's operational memory from its non-volatile memory and the card starts running again from the beginning.</p> <p>The reset button is slightly recessed from the front panel to prevent it from being accidentally pressed. A tool such as a bent paper clip is needed to press this button.</p>
	<p><b>Power supply lights</b></p> <p><b>+ 5-Volt light</b></p> <p>When lit, the +5V light indicates that the matrix's +5-volt power supply is actively supplying power to the CPU card.</p> <p><b>+3.3-Volt light</b></p> <p>When lit, the +3.3V light indicates that the matrix's +3.3-volt power supply is actively supplying power to the CPU card.</p>
	<p><b>Dot Matrix lights</b></p> <p>The rectangular array of lights just below the power-supply lights displays a number (either <b>1, 2, 3, or 4</b>) to indicate the currently selected configuration. The EHX configuration software controls these lights. The display will also indicate if the following errors are detected at startup:</p> <p><b>NVRAM error</b></p> <p>When the NVRAM is found to be corrupt at start up the config card will output the string <b>CHECK BATTERY</b>.</p> <p><b>Non matching slave firmware</b></p> <p>The Eclipse HX system only supports master and slave backup between two cards that are running the same version of firmware. In the case when a non matching slave card firmware version is detected the <b>NON-MATCHING SLAVE_FIRMWARE</b> banner is displayed by the master CPU card.</p> <p><b>Hardware version verification</b></p> <p>When an older, unsupported version of the MVX or E-Que FPGA is detected, the <b>EQue FPGA VERSION USUPPORTED</b> message is displayed by the master CPU card.</p>

	<p>Note: <i>The dot matrix lights will also display system information when the <b>ENG</b> button is pressed on the master CPU card. This is described below in the section on the <b>ENG</b> button.</i></p>
<p><b>D</b></p>	<p><b>Status lights</b></p> <p><b>OK Light</b></p> <p>When flashing, the OK light indicates that the CPU card is successfully communicating with the EHX configuration software.</p> <p><b>IPC (Interprocessor Communication) Light</b></p> <p>The interprocessor communication (IPC) light only operates when there are two CPU cards in the matrix. When lit, the light indicates that the two CPU cards are exchanging information.</p> <p><b>Master Light</b></p> <p>An Eclipse HX-Omega system can have two CPU cards, although the system will operate with only one. If the primary card becomes unavailable for any reason, the second card can serve as backup while the primary card is repaired or replaced.</p> <p>The "master" light illuminates on whichever CPU card is currently serving as master. If there is a backup CPU card in the matrix, its "master" light will not illuminate if the primary card is acting as master.</p> <p><b>LAN A Light</b></p> <p>When a local area network (LAN) is connected to the matrix's LAN A port, the CPU card's LAN A LED lights to indicate a connection to the Eclipse Configuration Software LAN A port.</p> <p><b>LAN B Light</b></p> <p>When a second local area network is connected to the matrix's "LAN B" port, the CPU card's "LAN B" LED lights to indicate a connection to the Eclipse HX configuration software (EHX) LAN B port.</p> <p><b>Sync Light</b></p> <p>When multiple Eclipse HX matrices are connected together the "sync" light illuminates to indicate that the matrices are connected and synchronized.</p> <p><b>SI Light</b></p> <p>The SI light flashes to indicate communications activity.</p>
<p><b>E</b></p>	<p><b>Configuration [ CONFIG ] button</b></p> <p>The CPU card can hold four complete system configurations in its operational memory. When the <b>CONFIG</b> button is pressed the number of the currently active configuration (either <b>1, 2, 3, or 4</b>) appears in the dot-matrix display.</p>

	<p>Each time the button is subsequently pressed the next configuration number in the series appears in the dot-matrix display. The numbers cycle forward until all of the choices have been displayed, then start again at <b>1</b>.</p> <p>When a non-active configuration's number appears in the display, it flashes to indicate its non-active status. When an active configuration's number (either <b>1, 2, 3, or 4</b>) appears in the display, it illuminates solidly (without flashing) to indicate that it is the active configuration.</p> <p>To select one of the four configurations from the CPU card</p> <ol style="list-style-type: none"> <li>1. On the front of the CPU card, repeatedly press the <b>CONFIG</b> button until the number of the desired configuration (<b>1, 2, 3, or 4</b>) is shown by the dot matrix display.</li> <li>2. When the desired number is displayed, press and hold the <b>CONFIG</b> button until the display stops flashing. This should take about three seconds.</li> </ol> <p>The selected configuration has now been activated.</p> <p>Note:</p> <p><i>The CPU card includes an additional, embedded configuration, which can be activated for fast fault checking following a system upgrade or field install. For more information, see <b>5.5.1 Using the embedded configuration.</b></i></p>
<p><b>F</b></p>	<p><b>Engineering [ ENG ] button</b></p> <p>This button is used to reset the system to the default IP address (169.254.0.100) with DHCP enabled and to display system information on the LED dot matrix (see <b>5.2 Setting the default IP Address</b>).</p> <p><b>System status</b></p> <p>If the <b>ENG</b> button only on the master CPU is pressed the following system information will be displayed on the LED dot matrix:</p> <ul style="list-style-type: none"> <li>• <b>Eclipse release.</b> For example, V7.0 at 7.0.</li> <li>• <b>Eclipse IP address.</b> IP address of the LAN 1 port, for example 169.254.000.100.</li> </ul> <p>Note:</p> <p><i>If this address was not statically allocated, but instead was allocated via DHCP server this will be pre-pended by <b>DHCP ENABLED</b>.</i></p> <ul style="list-style-type: none"> <li>• <b>System number.</b> This is only output if the rack is part of a linked set. It is the system number of the node within the linked set (for example, <b>SYSTEM 3</b>).</li> </ul>

	<ul style="list-style-type: none"> <li>• <b>Software version number.</b> Version number of the config card software (for example, <b>RACK 1.0.2.1</b>).</li> <li>• <b>Hardware serial number.</b> For example, <b>SERIAL 2251</b>, in the case where the HW serial number is 2251.</li> </ul>
	<p><b>Full Reset button</b></p> <p>When a full reset is performed, all cards in the matrix reset regardless of any system preferences in the program software and non-volatile memory are cleared.</p> <p>To perform a full reset:</p> <ol style="list-style-type: none"> <li>1. Press and hold the card's lower <b>RESET</b> button (the <b>Full reset</b> button).</li> <li>2. Simultaneously press and release the card's upper <b>RESET</b> button.</li> <li>3. Continue holding the card's lower <b>RESET</b> button for two seconds. The card then performs a full reset.</li> </ol> <p>The same configuration that was active before the system was reset will be active after reset.</p> <p>When the cards and connected audio devices reset, they momentarily stop their current activity and restart. During this process configuration information is downloaded to the cards and audio devices from the CPU card's non-volatile RAM.</p> <p><i>Note: Under normal operating conditions it is not necessary to perform a full reset. Technical personnel might perform a full reset if they believe that the CPU card is operating incorrectly as a result of corruption of the microprocessor's internal data or instruction sequence.</i></p>

**Table 5-1: Key to Figure 18: CPU card lights and controls**

### 5.5.1 Using the embedded configuration

In addition to the four EHX configurations that can be stored on the card, the CPU card also includes an embedded configuration. The embedded configuration is designed for fast fault checking following a system upgrade or field install (for example, checking hardware connections with user panels and interface cards).

**Note:** The embedded configuration may also be used as a back-up configuration, in the very rare event that a system error renders the other configurations unusable.

To activate the embedded configuration:

- 1) On the front of the CPU card, press and hold the **CONFIG** and the **ENG** buttons.

- 2) Simultaneously, reset the CPU card by pressing and holding the CPU card's lower **RESET** button (the **Full reset** button).

**Note:** A tool, such as a pin, is used to press and hold the **RESET** button.

- 3) Continue holding the **CONFIG**, **ENG** and **RESET** buttons until the CPU card's dot matrix display displays **0**. It may take 1 - 2 seconds before **0** is displayed.

The embedded configuration has now been activated.

To deactivate the embedded configuration, perform a CPU card reset.

The configuration (**1**, **2**, **3** or **4**) that was previously active on the CPU card replaces the embedded configuration as the active configuration.

## 5.6 Analog port card (MVX-A16) front-panel lights and controls

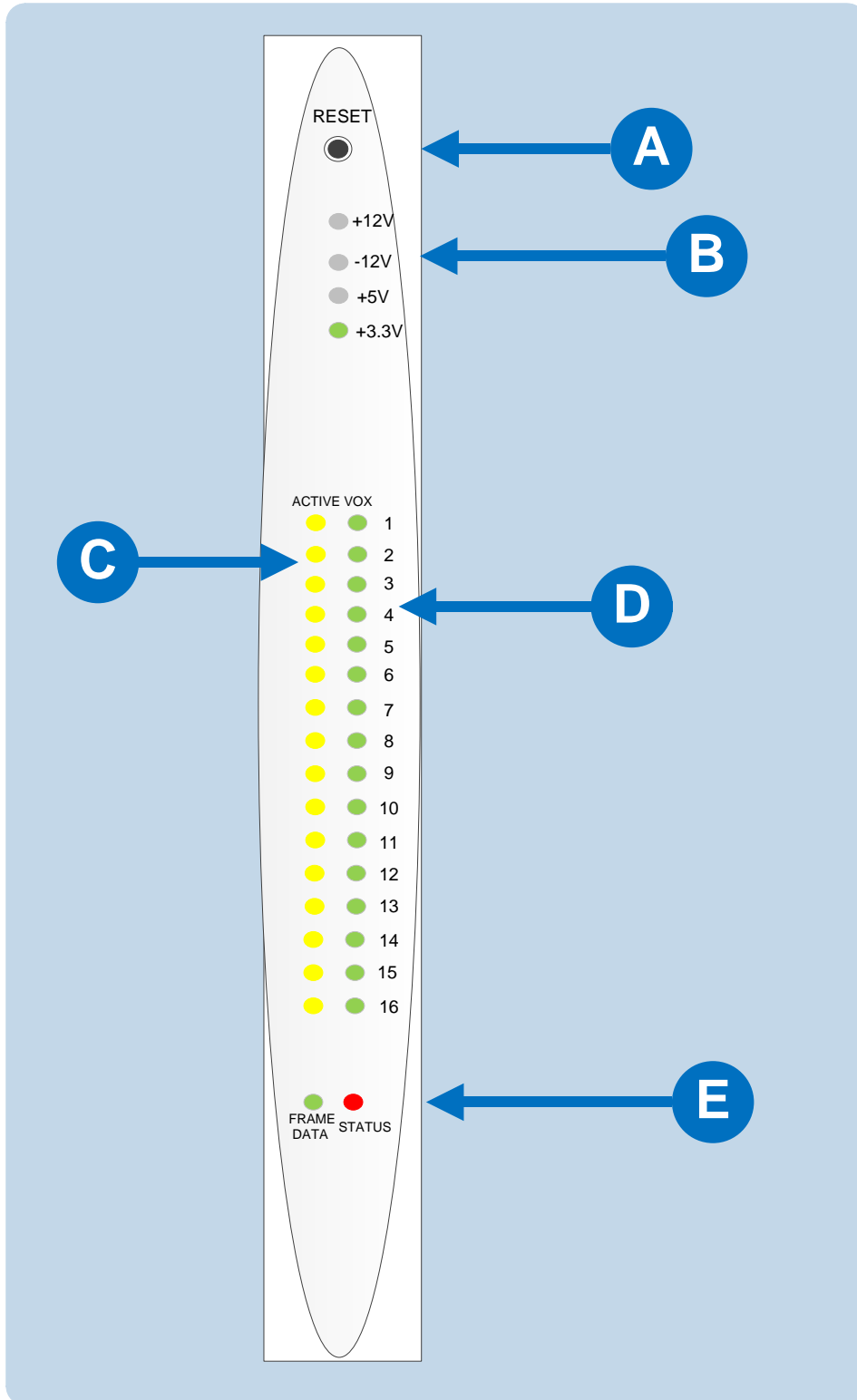



Figure 5-2: Analog port card (MVX-A16) front panel lights and controls

Key to Figure 19: Analog port card (MVX-A16) lights and controls	
Feature	Description
<b>A</b>	<p><b>RESET button</b></p> <p>Pressing the <b>RESET</b> button causes the card and all connected audio devices to momentarily stop their current activity and to restart. The card's "matrix data" light goes off when the reset starts and comes back on when the reset is complete.</p> <p>During the reset, configuration information downloads to the card and its connected audio devices from the CPU card. If the entire system is operating except for one port card, or one or more panels connected to the card, press the reset button for that card only.</p> <p><b>Tip:</b> <i>The reset button is slightly recessed from the front panel to prevent it from being accidentally pressed. A tool such as a bent paper clip is required to press this button.</i></p>
<b>B</b>	<p><b>Power supply lights</b></p> <p><b>+12-Volt and -12-Volt Power Supply Lights</b></p> <p>The matrix's +12-volt and -12-volt power supplies provide electric current to these two green lights. When lit, these lights indicate that the matrix's +12-volt and -12-volt power supplies are present and supplying electric current to the card.</p> <p><b>+5-Volt Power Supply Light</b></p> <p>The matrix's +5-volt power supply provides electric current to this green light. When lit, the light indicates that the +5 supply is present and supplying electric current to the card.</p> <p><b>+3.3-Volt Power Supply Light</b></p> <p>The matrix's +3.3-volt power supply provides electric current to this green light. When lit, the light indicates that the +3.3-volt supply is present and supplying electric current to the card.</p>
<b>C</b>	<p><b>Active Lights</b></p> <p>When lit, an <b>active light</b> indicates successful communication between the port card and a connected device such as an intercom panel or interface.</p> <p>Each of the port card's 16 <b>yellow active lights</b> corresponds to one of 16 rear-panel connectors or "ports" to which audio devices can be connected.</p>
<b>D</b>	<p><b>VOX Lights</b></p> <p>When lit a <b>VOX</b> light indicates that the audio level on a connected device, such as an intercom panel or interface, has exceeded a</p>

	<p>preset threshold. The threshold audio level is set through the EH application.</p> <p>Each of the port card's 16 <b>green</b> VOX lights corresponds to one of 16 rear-panel connectors or "ports" to which audio devices (intercom panels or interfaces) can be connected.</p>
	<p><b>Matrix Data Light</b></p> <p>The <b>green matrix data light</b> flashes (1: 1 0.5Hz) to indicate successful communication between the port card and the CPU card.</p> <p><b>Status Light</b></p> <p>The <b>red status light</b> illuminates to indicate a failure in communication between the port card and the CPU card.</p>

**Table 5-2: Key to Figure 19: Analog port card (MVX-A16) front panel lights and controls**

## 5.7 Power supplies

The Eclipse HX-Omega has two Euro Cassette power supply units that can be easily installed or removed as needed. One power supply unit can power an entire matrix; the second unit provides a backup in case of an equipment failure.

In addition, the two supplies have separate IEC connectors to AC mains power, and are designed for completely automatic and transparent changeover between supplies in the event of an outage on one of the AC mains circuits. For this feature to work, each power supply should be connected to a different AC mains branch.

If the temperature inside the Eclipse matrix exceeds a threshold, both an audible alarm and a warning light switch on, allowing the system operator to diagnose and correct power anomalies while the system remains in operation.

Eclipse HX-Omega matrices may be fitted with **XP** (part 740101Z) or **Power-One** (part 720379Z) power supply units, depending on the date of manufacture.

**Note:** A total of four E-Que, IVC-32 or LMC-64 interface cards may be fitted to an Eclipse HX-Omega unless the matrix is fitted with a Power-One PSU. If the matrix has a Power-One PSU, up to six E-Que, IVC-32 or LMC-64 cards may be fitted with the following condition:

- You can only have four wireless E-Que cards
- You can only have four E-Que cards with EM signaling enabled.

A fan tray is recommended if you are using more than four E-Que, IVC-32 or LMC-64 cards.



The different types of power supply units **must not be mixed** in an Eclipse HX-Omega matrix; if one of the pair of power supplies is replaced it must be replaced with the same type of power supply unit. If this is not possible both power supplies must be replaced with power supply units of the same type.

Power-One power supplies are identified by the part number on the front of the unit. XP units do not have a part number on the front of the unit.

Each cassette has two status lights located on the power supply unit in the upper left corner. The green light stays on continuously to indicate that the unit is receiving appropriate power. The **amber** (XP unit) or **red** (Power-One) light goes on when a DC output or AC input falls too low.

## 5.8 Diagnosing power supply problems

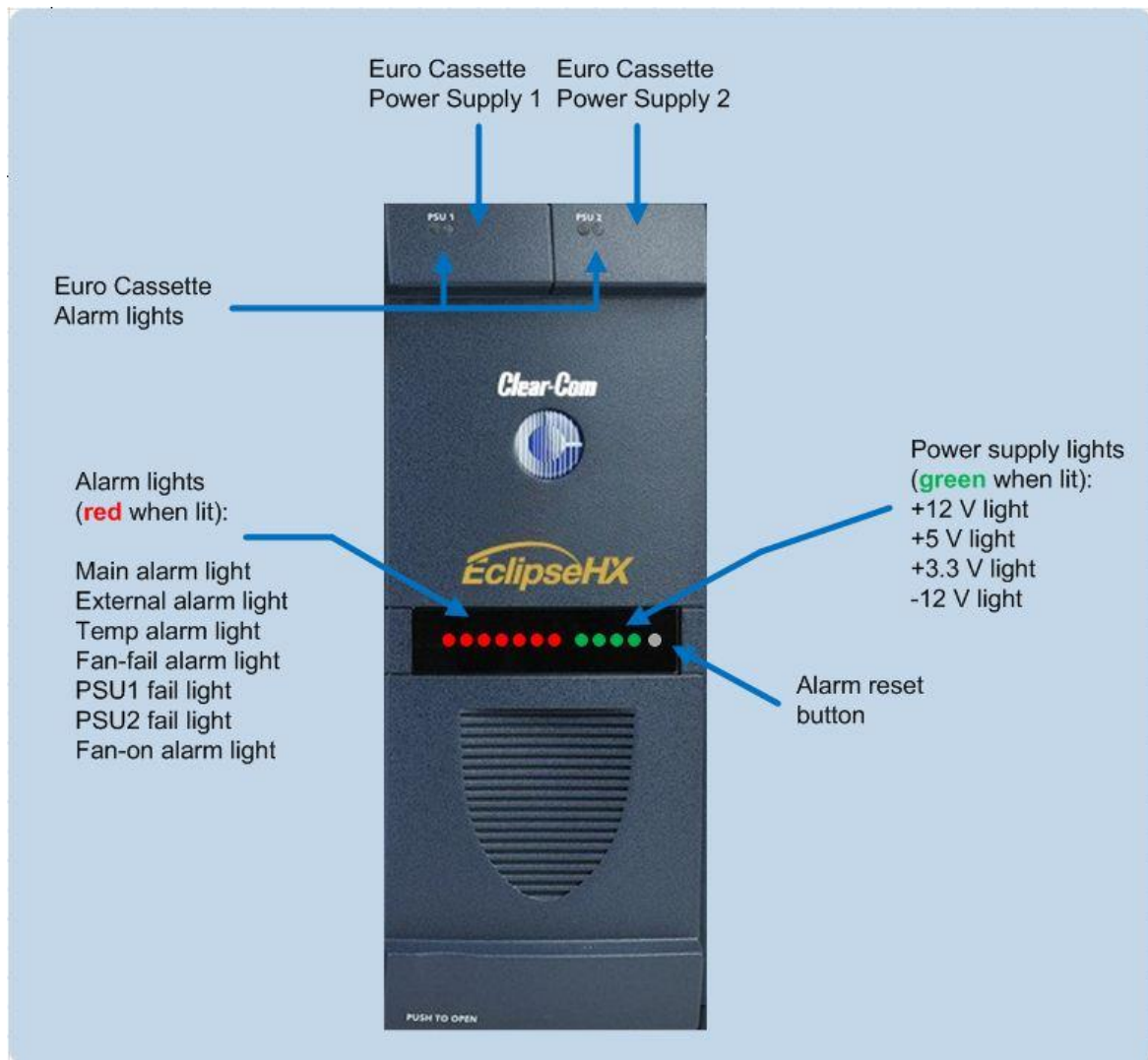

Figure 5-3: Power supplies: Front panel lights and controls

**Figure 20** illustrates the front panel alarm lights, power supply lights, and reset button. An alarm source triggers the main alarm light and also one of the additional six red alarm lights, allowing the system operator to identify or correct alarm conditions before they affect the operation of the matrix.

Each of the four **green power supply lights** stays on continuously to show that the power supplies are receiving sufficient AC current. When one of these lights switches off, the power supplies must be replaced or repaired.

Under normal operating conditions, the **red front-panel alarm lights** stay off, while the **green power supply lights** stay on continuously.

**Note:** The XP type power supplies (part 740101Z) may need to be adjusted if E-Que, E-FIB, IVC-32 or LMC-64 interfaces are installed. Power-One power supply units (part 720379Z) should **not** be adjusted.

### 5.8.1 Conditions that cause an alarm

The following conditions trigger an alarm:

- If any of the voltages produced by the first power supply unit fall below normal levels.
- If any of the voltages produced by the second power supply unit fall below normal levels.
- If an internal matrix alarm condition activates a matrix relay to turn on an external alarm.
- If the active CPU card exceeds a temperature threshold.
- If either of the CPU cards is removed from the matrix.
- If either of the matrix's two cooling fans stop operating.
- If the temperature inside the Eclipse matrix exceeds a set threshold.

### 5.8.2 Main alarm light

An alarm condition triggers the following events:

- The **red** main alarm light flashes.
- The matrix's internal alarm buzzer sounds.

Any installed alarm relay outputs switch to active (the normally open contact closes and the normally closed contact opens). When the alarm relay activates, it can cause an externally connected device like a light or buzzer to switch on.

One of the six **auxiliary red alarm lights** may go on, to more precisely indicate the source of the alarm condition (see **5.8.4 Auxiliary alarm lights**).

### 5.8.3 Alarm Reset button

When the alarm reset button is pressed the following events take place, even if the alarm condition has not been corrected:

- The internal audible alarm buzzer stops buzzing.
- Any wired relay contacts return to their inactive state. If these relays are connected to external alarm lights or alarm buzzers, those lights or buzzers shut off.
- If the original alarm condition still exists, the red main alarm light on the matrix's front panel continues to flash. The red main alarm light only stops flashing when all original sources triggering the alarm are corrected.
- If a new alarm condition or conditions occur before the original alarm conditions are corrected, the internal buzzer and relay contacts will not reactivate. They will only reactivate after all original alarm conditions are corrected.

### 5.8.4 Auxiliary alarm lights

When an alarm condition occurs, any of the six auxiliary alarm lights may switch on, in addition to the main alarm light, to help diagnose the alarm condition. The following sections describe the six auxiliary alarm lights.

#### External Alarm (EXT ALARM)

The external alarm (labeled **EXT ALARM**) light switches on to indicate that an alarm condition has triggered the built-in relay outputs to turn on any externally installed alarms such as lights or bells.

The external alarm is connected to the matrix through the 9-pin D-type connector on the matrix's rear panel labeled **Alarm I/O**.

#### Temp alarm (Temperature alarm)

The **red Temp alarm** light switches on to indicate one or both of the following:

- The active CPU card has detected a temperature in the matrix above a threshold.
- One of two CPU cards has been removed from the matrix.

**Note:** This feature only operates if there are two CPU cards installed in the matrix. If there is only one CPU card, the Temp alarm light does not switch on if the card is removed.

#### Fan-fail alarm

The **red fan-fail alarm light** illuminates when **either** fan in the power-supply module stops rotating correctly.

## PSU1 Fail

When the first power supply unit is operating correctly, the **red PSU1 light** stays off, while the four **green power supply lights** (+12V, +5V, +3.3V, -12V) stay on continuously.

If a DC output or AC input to the first power supply drops too low, the **red PSU1 light** switches on. The **amber** (XP) or **red** (Power-One) light on the power supply unit itself also switches on to indicate the same condition. One of the green power supply lights may then switch off to help indicate the source of the trouble.

**Note:** The PSU1 fail light only works if the first power supply is plugged into the matrix's midplane from inside the matrix.

A temperature sensor inside the power supply senses if the power supply overheats, and switches on the second matrix cooling fan. The **red Temp light** switches on to indicate that the active CPU card, not a power supply, has overheated.

## PSU2 Fail

When the first power supply unit is operating correctly, the **red PSU2 light** stays off, while the four **green power supply lights** (+12V, +5V, +3.3V, -12V) stay on continuously.

If a DC output or AC input to the first power supply drops too low, the **red PSU2 light** switches on. The **amber** (XP) or **red** (Power-One) light on the power supply unit itself also switches on to indicate the same condition. One of the green power supply lights may then switch off to help indicate the source of the trouble.

**Note:** The PSU2 fail light only works if the first power supply is plugged into the matrix's midplane from inside the matrix.

A temperature sensor inside the power supply senses if the power supply overheats, and switches on the second matrix cooling fan. The **red Temp light** switches on to indicate that the active CPU card, not a power supply, has overheated.

## Fan-On alarm light

Two fans deliver forced air cooling to the matrix's power supplies. The primary fan runs continuously. If a temperature exceeding a threshold is detected in a power supply and extra cooling is required, a second fan switches on to increase the air flow.

The **fan-on alarm light** illuminates **red** to indicate that the second fan is on.

### 5.8.5 Power Supply Lights

The **green power-supply lights** illuminate to indicate that the power supplies are receiving +12 V, -12 V, +5 V, and 3.3 V power.

## 5.9 Connecting the matrix

**Note:** For detailed information about connecting the matrix to panels, interfaces and other devices, see **4 Installing the Eclipse HX-Omega**.

The Eclipse HX-Omega matrix connects to devices such as the external computer that runs the EHX configuration software, panels, interfaces, and other matrices through its rear-panel hardware connectors, often called **ports**.

These connectors are housed in modular removable panels. Each panel is associated with a corresponding front-panel circuit card.

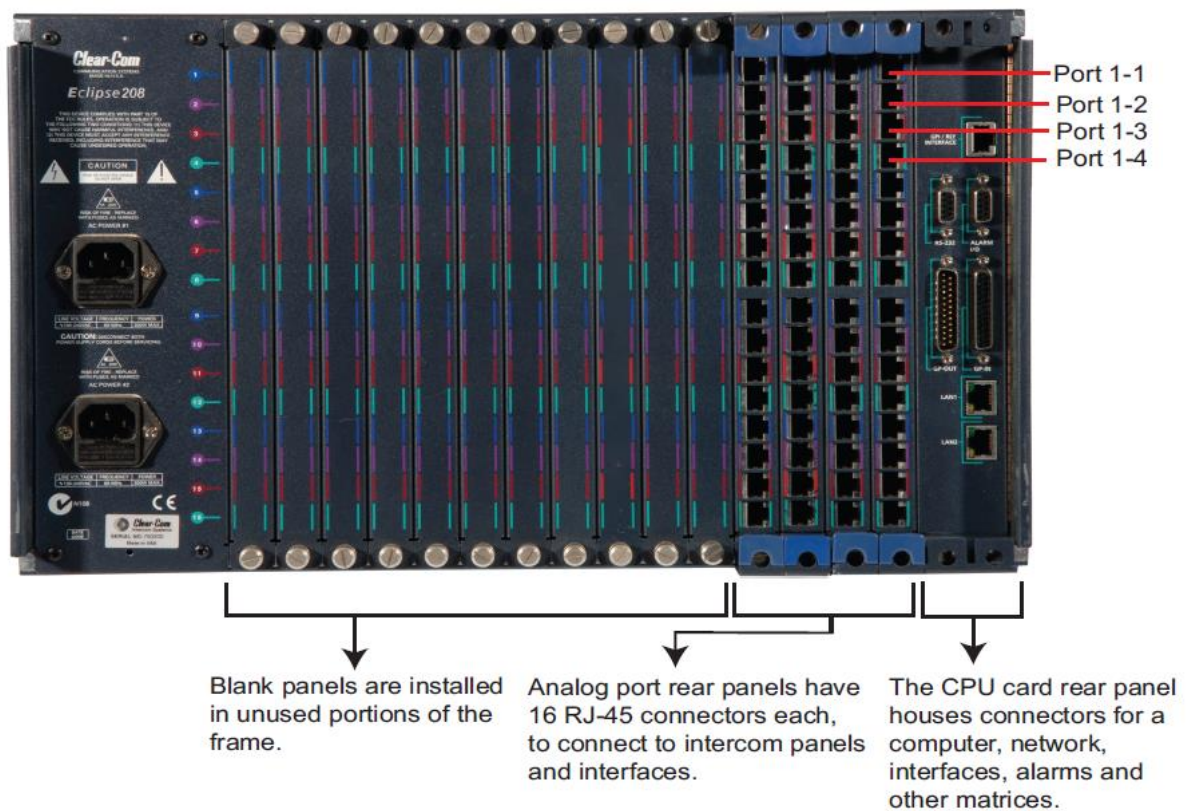

Figure 5-4: Eclipse HX-Omega rear panels

### 5.9.1 Eclipse HX-Omega rear connector panels

There are seven types of rear-connector panels:

Panel	Description
<b>CPU card</b>	A CPU-card rear panel holds the various connectors associated with the CPU card, such as the RS-232 connector for the configuration computer.
<b>Analog port card (MVX-A16)</b>	Analog port-card rear panel holds the sixteen RJ-45 connectors associated with its corresponding analog port-card front panel.  User panels, interface modules and other intercom devices connect to the matrix through this rear-connector panel.
<b>E-MADI64 card</b>	An E-MADI64 rear card comprises a MADI fiber connector, MADI input and output coaxial cable connectors, and a coaxial Video / Word clock input.
<b>E-FIB fiber card</b>	An E-FIB fiber card provides two ports to connect fiber network cables.
<b>E-Que card</b>	An E-Que card provides eight RJ-45 ports for connection to wireless equipment and three RJ-45 ports for DECT sync and LAN connections.
<b>IVC-32 card</b>	An IVC-32 card provides a RJ-45 port for connection to an IP network. No other ports are used.
<b>LMC-64 card</b>	An LMC-64 card provides a RJ-45 port for connection to an IP network. No other ports are used.

Table 5-3: Rear connector panels

**Note:** A **blank panel** covers an unused slot in the matrix.

## 5.9.2 Connecting the CPU Card

The rear-connector panel associated with the CPU card holds seven connectors (see **Figure 5-4: Eclipse HX-Omega rear panels**).

For a detailed description of each connector, including wiring and pinout information, see **4.8.1 CPU card interface connectors**.

A matrix only requires one rear-panel CPU card, because whichever of the two front-installed CPU cards is acting as master will work in conjunction with this card. All other front cards, however, require their own rear-connector panel.

**Note:** For detailed information about connecting the matrix to panels, interfaces and other devices, see **4 Installing the Eclipse HX-Omega**.

### 5.9.3 Connecting interface cards

Each rear-connector panel associated with an **MVX-A16** (analog) interface holds the sixteen RJ-45 connectors that connect the matrix to intercom panels and interfaces. Each front-installed MVX-A16 port card requires a corresponding rear-connector panel.

Blank panels cover unused slots.

Each port on the matrix can be located and identified by using the rear-panel numbering grid.

- Columns 1 through 15 identify cards.
- Rows 1 through 16 identify ports on each card.
- Processor cards are designated P1 and P2.

**Note:** A port can be identified precisely by identifying its card number and port number on the card. For example, the ports on the first card are designated 1-1, 1-2, 1-3, 1-4, and so on; the ports on the second card are designated 2-1, 2-2, 2-3, 2-4, and so on.

Each rear connector panel associated with an **E-MADI64** interface card comprises:

- A MADI fiber connector.
- MADI input and output coaxial cable connectors.
- A coaxial Video / Word clock input.

Each rear connector panel associated with an **E-Que** interface card comprises eleven RJ-45 ports:

- Eight ports for connection to wireless equipment.
- Two ports for DECT sync.
- One port for LAN connections.

Each rear connector panel associated with an **IVC-32** interface card comprises eleven RJ-45 ports:

- Eight ports for connection to E1/T1 equipment (not used).
- Two ports for DECT sync (not used).
- One port for LAN connections (used for IP-enabled V-Series panels and Concert panels).

Each rear connector panel associated with an **LMC-64** interface card comprises eleven RJ-45 ports:

- Eight ports for connection to E1/T1 equipment (not used).
- Two ports for DECT sync (not used).

- One port for LAN interface used for broadcasting audio levels to Production Maestro Pro clients.

Each rear connector panel associated with an **E-FIB** interface comprises two fiber ports (TXVRA and TXVRB).

**Note:** For detailed information about connecting the matrix to panels, interfaces and other devices, see **4 Installing the Eclipse HX-Omega**.

## 6 *E-MADI64 card*

---

This chapter describes the **E-MADI64 card**.

The E-MADI64 is a **MADI (Multichannel Audio Digital Interface)** card, providing up to 64 duplex channels of AES3 digital audio over a coaxial cable or fiber pair between compatible devices.

You can limit the quantity of channels to 32, 56 or 64 channels in EHX.

The E-MADI64 card supports up to 32 V-Series Panels over a suitable infrastructure. See 6.5 V-Series Panels on E-MADI (Multi-channel Audio Digital Interface) for more information

Each E-MADI64 card set comprises:

- A front card with pin reset and various status indicators (including channel quantity, sample rate, power and diagnostic (active and error) indicators).
- A rear card with a MADI multimode fiber connector, MADI input and output coaxial cable connectors, and a coaxial Video / Word clock input.

The standard maximum cable length is 2km, using fiber cable, or 50m using coaxial cable. Up to 15km is available to special order, using the single mode fiber option.

**Note:** For the order in which all interface cards must be installed to the Eclipse HX-Omega, see **4.5 Installing interface cards**.

**Note:** All MADI channels have standard EHX settings, including VOX and in-use tally.

## 6.1 E-MADI64 front panel lights and controls

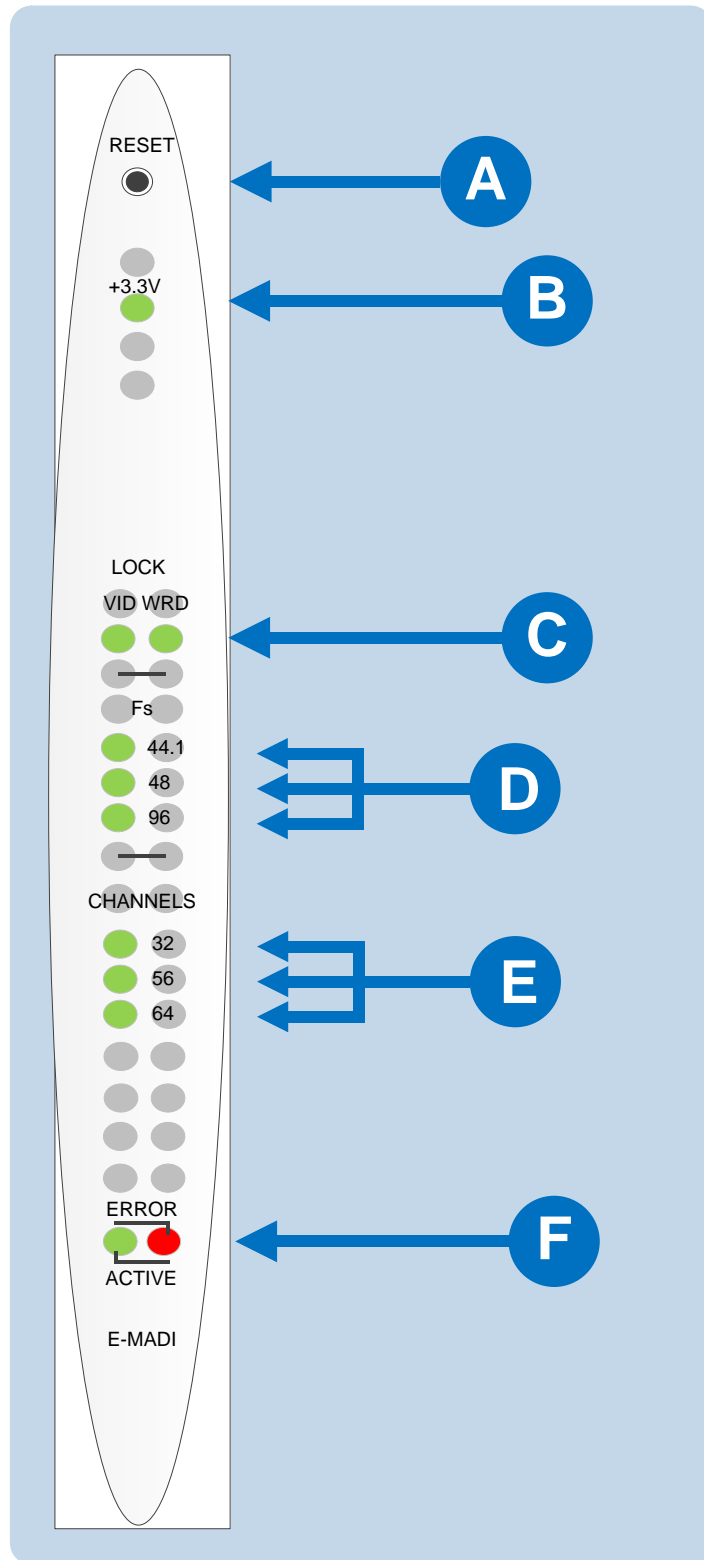

Figure 6-1: E-MADI64 front panel lights and controls

On a card with a clock source and MADI connections (where the received MADI signal matches the card set up), the following lights are lit: the **Lock source** LED [ **C** ], the **Sample rate (Fs)** LED [ **D** ], the **Channels** LED [ **E** ] and the **Active** LED [ **F** ]. The Error LED [also **F** ] is lit when there is no clock source or MADI input.

Key to Figure 22: E-MADI64 front panel lights and controls	
Feature	Description
<b>A</b>	<p><b>Reset button</b></p> <p>Pressing the <b>Reset</b> button causes the card and all links to momentarily stop their current activity and to restart. The <b>flashing green Active</b> light goes off when the reset starts and comes back on when the reset is complete.</p> <p>During the reset, configuration information downloads to the card and its connected matrices from the CPU card. If the entire system is operating except for one E-MADI64 card, press the reset button for that card only.</p> <p><b>Tip:</b> <i>The reset button is slightly recessed from the front panel to prevent it from being accidentally pressed. A tool such as a bent paper clip is needed to press this button.</i></p>
<b>B</b>	<p><b>+3.3-Volt Power Supply LED</b></p> <p>The matrix +3.3-volt power supply provides electric current to this <b>green</b> light. When lit, the light indicates that the +3.3-volt supply is present and supplying electric current to the card.</p>
<b>C</b>	<p><b>Lock source</b></p> <p>A <b>green</b> light indicates that the E-MADI64 card has locked to the clock source (<b>either</b> video (<b>VID</b>) or Word Clock (<b>WRD</b>)).</p>
<b>D</b>	<p><b>Sample rate or Sf (Sampling frequency)</b></p> <p>A <b>green</b> LED indicates the current sampling rate of the MADI channels. The sample rate is determined in EHX when a video sync is used, or automatically detected from the clock source when a Word clock is used.</p> <p>Note: <i>If the quantity of channels is <b>32</b>, the sampling rate is either <b>44.1KHz</b>, <b>48KHz</b> or <b>96KHz</b>. If the quantity of channels is either <b>56</b> or <b>64</b>, the sample rate is either <b>44.1KHz</b> or <b>48KHz</b>.</i></p> <p><i>The Sample rate LED on the front of the E-MADI64 will oscillate between two sample rates when the received sample rate differs from the transmitted sample rate.</i></p>
<b>E</b>	<p><b>Channels</b></p>

	<p>A <b>green</b> LED indicates the quantity of MADI channels. The number of channels is determined in EHX. You can select from 32, 56 or 64 full duplex channels of digital audio.</p> <p>Note: <i>Channel LEDs on the front of the E-MADI card will oscillate between two channel numbers when the number of channels received differs from the number of channels set in EHX.</i></p>
<p><b>F</b></p>	<p><b>Diagnostics</b></p> <p><b>Active LED</b></p> <p>The <b>Active (matrix data) LED flashes green</b> (1:1 at 0.5Hz) to indicate successful communication between the E-MADI64 master card and the CPU card.</p> <p><b>Error LED</b></p> <p>The <b>Error (status) LED</b> is lit <b>solid red</b> when there is no clock source or MADI input.</p> <p>Note:</p> <p><i>During boot up, the <b>Active</b> and <b>Error LEDs</b> flash rapidly until the boot sequence is completed.</i></p>

**Table 6-1: Key to Figure 23: E-MADI64 lights and controls**

## 6.2 E-MADI64 rear panel connectors

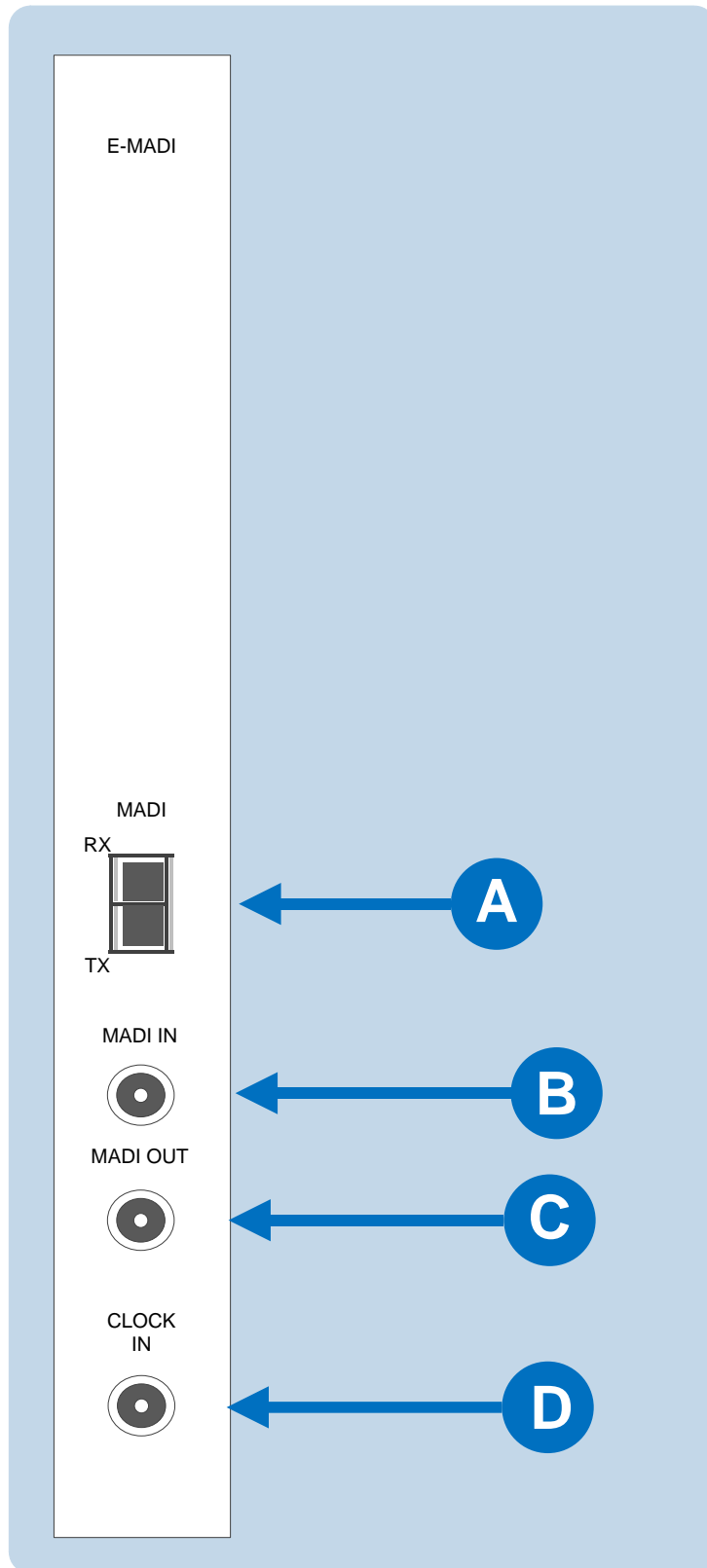

Figure 6-2: E-MADI64 rear panel connectors

**Warning: Eye Safety**

**This LED based single mode transceiver is a Class 1 LED product.** It complies with IEC 60825-1/A2:2001 and FDA performance standards for laser products (21 CFR 1040.10 and 1040.11) except for deviations pursuant to Laser Notice 50, dated July 26, 2001.

Normally a protective plug is fitted to the fiber connector to protect the connector from damage or the entry of foreign materials. The protective plug should only be removed in order to fit the fiber optic cable. Replace the plug when the cable is unplugged.

Key to Figure 23: E-MADI64 rear panel connectors	
Feature	Description
<b>A</b>	<b>MADI Fiber connector (Tx and Rx)</b> The connector is a fiber (MM) SFP Duplex LC removable transceiver module
<b>B</b>	<b>MADI IN coaxial connector</b>
<b>C</b>	<b>MADI OUT coaxial connector</b>
<b>D</b>	<b>Video / Word clock coaxial connector</b> The clock source is either NTSC/PAL Black and burst, Tri Level HD video sync or AES Word Clock.

Table 6-2: Key to E-MADI64 rear panel connectors

## 6.3 MADI channels

The E-MADI64 card can route up to 64 MADI channels of audio.

**Note:** The channel modes for the E-MADI64 are 32, 56 and 64. For more information see **Table 6-3: E-MADI64 channel modes.**

Each MADI audio channel:

- Carries one (or a mixture of) any of the 512 HX-Omega backplane timeslots.
- Is 24 bits in length.

You can configure the input and output gain for each MADI audio channel in EHX and / or Production Maestro Pro software. The configurable range for MADI audio channels is **-72dB to +18dB**.

### 6.3.1 MADI channel labeling

The 4-character channel ID for each MADI input channel is taken from the provided embedded data bits. The channel ID for each MADI output channel can be re-labeled in EHX, or alternatively replaced with Production Maestro Pro alias labels.

This means that supported user panels can automatically show the MADI channel ID (or Alias as supplied from Production Maestro Pro).

The channel labeling options in EHX are therefore:

- To use the 4-character, third party ID, provided from the input channel.
- To use the Production Maestro Pro Alias.
- To disable the ID and use the EHX port name.

## 6.4 Setting up the E-MADI64 card

To set up the E-MADI card:

- 1) With the Eclipse HX-Omega powered off, insert the E-MADI front and rear cards into the matrix.
- 2) Power up the Eclipse HX-Omega and open the EHX configuration software.
- 3) Add the E-MADI64 cards to the EHX configuration.

If you are creating a new configuration, use **Layout mode** to discover the cards:

- a. Drag the matrix into the work area.
- b. The **New Configuration** dialog is displayed. Select **Discover Hardware**.
- c. Click **Ok**.

If this is an established configuration:

- a. Go to **Hardware > Cards and Ports**.
- b. To add the cards, do either of the following:
  - Click **Detect New Hardware**. The cards are discovered and automatically assigned to a slot on the matrix.
  - Use the drop-down lists to manually assign the cards to slots on the matrix.

- 4) Configure EHX settings for the E-MADI64 cards. Standard EHX settings (including **VOX** and **In-use** tally) are applicable to **all** E-MADI64 channels.

**Note:** **Card Properties** permits sample rate selection when syncing to video signals. It is only used when **not** using the **Word Clock Source Sync** (see below).

**Card Properties** always defaults to the E-MADI64 standard for the **number of channels**:

E-MADI64 channel mode	Sample rate	Configurable ports
<b>32</b>	96k	32
<b>56</b>	44.1k or 48k	56
<b>64</b>	44.1k or 48k	64, 32 or 16

**Table 6-3: E-MADI64 channel modes**

- 5) Apply the changes to the matrix with a reset.

### 6.4.1 Connecting a Word Clock source

If you connect the **Word Clock** source to the **Clock Input** connector on the rear card (see **Table 6-2** above):

- The **WRD** LED on the front of the E-MADI64 card is lit **solid green**, indicating that the word clock has been detected and locked onto.
- The number of configured ports and the detected sample rate (as provided by the word clock) is indicated by **flashing green** LEDs (1:1 at 0.5Hz) on the front of the E-MADI64 card.
- The **Error** LED on the E-MADI64 card is lit **solid red**.

### 6.4.2 Connecting a video source

If you connect a video source to the **Clock Input** connector on the rear card (see **Table 6-2** above):

- The **VID** LED on the front of the E-MADI64 card is lit **solid green**, indicating that the word clock has been detected and locked onto.
- The number of configured ports and the sample rate (configured in EHX) is indicated by **flashing green** LEDs (1:1 at 0.5Hz) on the front of the E-MADI64 card.

### 6.4.3 Connecting E-MADI64 Audio (using Coaxial or Fiber cable)

When you connect the external E-MADI64 Audio (using Coaxial or Fiber cable) to the rear of the E-MADI64 card:

- 1) The sample rate and the number of configured ports is indicated by a **solid green** LED on the front of the E-MADI64 card.
- 2) The **red Error** LED on the E-MADI64 card is **turned off**.
- 3) When the number of received channels differs from the number of channels configured in EHX, the **Channel** LEDs on the front of the E-MADI64 card **flash green**, oscillating between 2 types of port numbers.
- 4) When the received sample rate differs from the configured sample rate, the Sample rate LEDs on the front of the E-MADI64 card **flash green**, oscillating between 2 types of sample rates.
- 5) Audio passes into and out of the E-MADI64 card to the HX-Omega backplane.

## 6.5 V-Series Panels on E-MADI (Multi-channel Audio Digital Interface)

The E-Madi card supports up to 32 V-Series panels over a suitable infrastructure. To set up V-Series panels on MADI you need to:

- Run EHX version 8.5 or above.
- Configure the panel audio in the EHX software and the MADI software as necessary.
- Ensure that the panel is fitted with a V-Series AES options module (see **V-Series Panel User Guide; 4.2.2 V-Series main panel rear connectors (AES 3)** for more information.)

How the ports are configured in the software will depend on which MADI is used. See below for details.

### 6.5.1 Configuring audio over MADI, the general case

Most third party equipment (e.g. RME, Lawo) treats the AES (Audio Engineering Society) streams from a MADI as 32 linked pairs, A and B channel together. So in the general case, the following strategy should be used to route the AES streams:

In the card/port configuration screen in EHX, the panels should be configured to the odd numbered ports (taking the first port as 1) of the E-MADI card. The even numbered ports may be left unused (Empty), leaving the panel with only the main channel audio (channel A). See Figure 6-3.

**Note:** It is not necessary to define a block of panels as consecutive odd numbers. For example, ports 1,3,9,11,51 could be defined as panels, with all the other slots unused or used for other purposes if required.

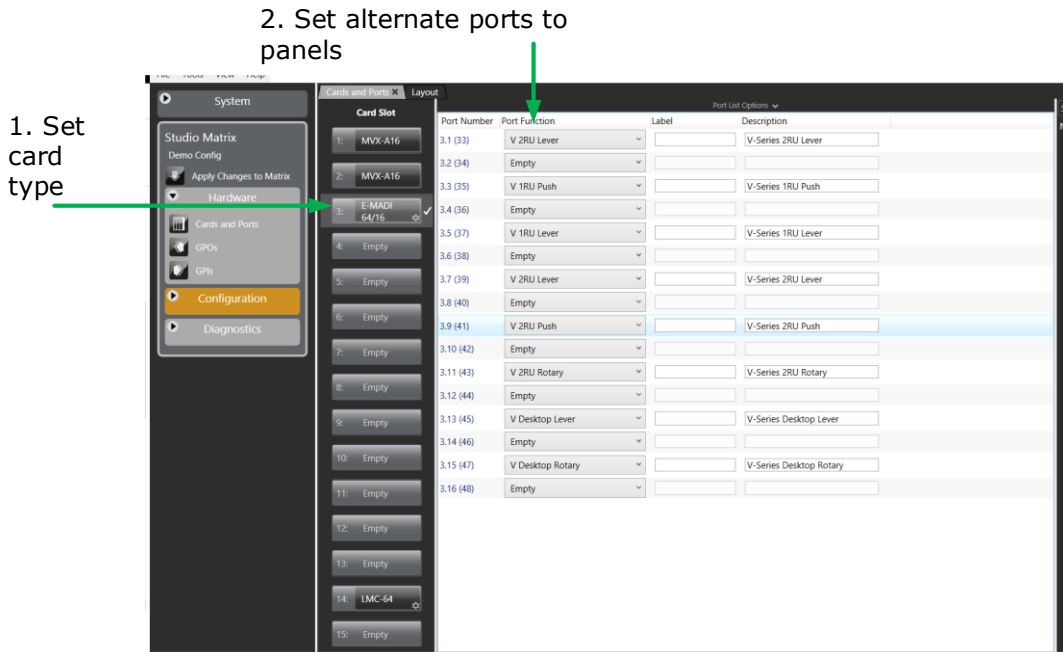

To configure binaural audio on V-series panels on a MADI card in EHX go to: **EHX>Hardware>Cards and Ports.**

This example shows how to configure ports for audio streamed in pairs, A and B. Note that alternate ports have been set to accommodate paired audio streams.

**Figure 6-3 Setting port configuration to panels with third party MADI routers; general case**

## 6.5.2 Configuring audio over Optocore/ProGrid MADIs

Optocore/ProGrid MADIs have the advantage of allowing fully flexible audio routing.

Optocore/ProGrid interfaces allow each channel of the MADI to be routed individually to any channel on any destination node. The AES streams do not have to be routed and configured in pairs. The ProGrid equipment allows fully flexible routing and it is possible to mix close packed mono and conventional stereo pairs on one MADI interface. It is the routing matrix in the ProGrid equipment that is used to get the main panel port to the A channel of the AES interface.

For example, if ports 1,2,3,4,5,7,9,11... are defined as panels in EHX, the ProGrid must be used to ensure that the channels 1,2,3,4,5,7,9,11... are routed to and from the A channels of the AES interfaces.

Because of the free routing capabilities of the ProGrid, the routing of panel data is totally free format so it is possible, for example, to define stereo panels where the main and aux channels are not defined on adjacent ports of the MADI. See Figure 6-4.

**In all cases, when using a router such as ProGrid, ensure that the configuration of the E-MADI card and the configuration of the ProGrid matrix are consistent with each other.**

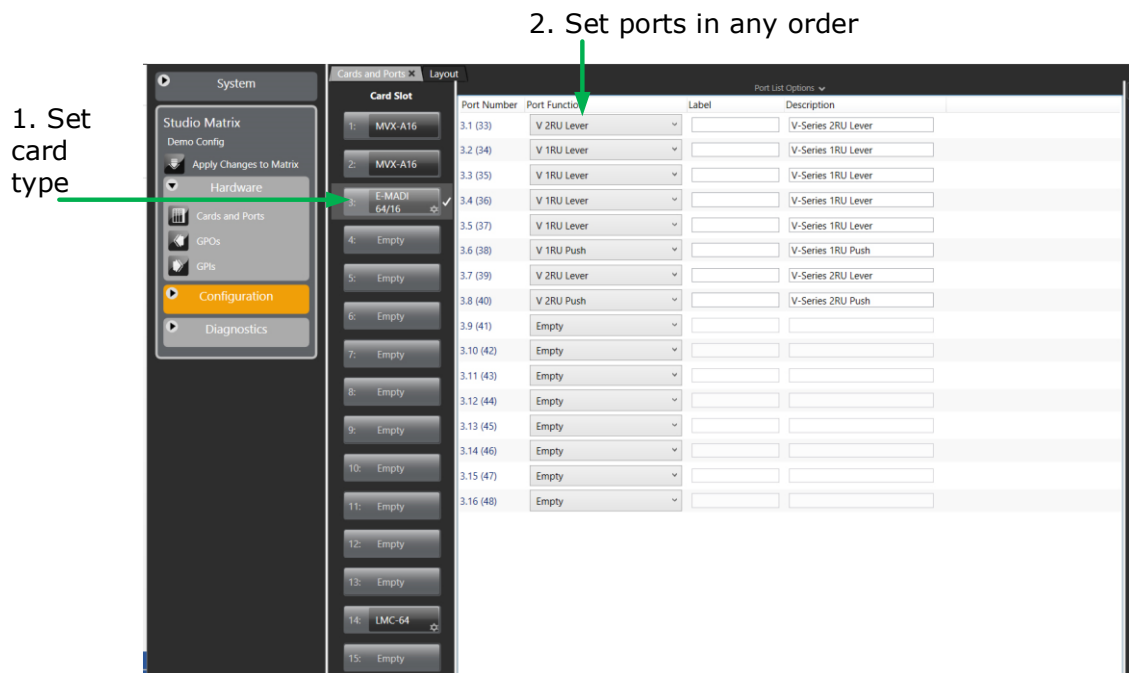

To configure V-series panels on a MADi card in EHX go to: **EHX>Hardware>Cards and Ports.**

This example shows how to configure ports for audio that is not streamed in pairs by the MADi interface (ProGrid). Note that ports do not have to be set to accommodate paired audio streams.

**Figure 6-4 Setting port configuration to panels with ProGrid routers**

## 6.6 Configuring binaural audio with E-MADI cards

When routing audio to a V-Series panel with a MADi64 card, the AES (Audio Engineering Society) audio streams can be set to operate binaurally (one channel to each headphone on a headset) using the main channel audio (A) and the auxiliary channel audio (B).

When setting up binaural audio over a V-Series panel with a MADi64 card you must:

- Configure the panel audio in the EHX software and the MADi software as necessary.
- Set the Audio Mixer screen option to display additional channels in the EHX user interface so they can be routed to the desired outputs.
- Use a headset with a minimum of a 5-pin input (use with an XLR5 or 7 adapter).

## 6.7 Configuring binaural panel audio in software

The main audio channel and the auxiliary audio channel need to be directed to the desired ports. This is achieved in the EHX software (**EHX>Hardware>Cards and Ports**). How the two audio streams (channels A and B) are set up will depend on which MADIs are used to connect the audio between the E-MADI64 card and the AES (Audio Engineering Society) module fitted to the V-Series panel.

### 6.7.1 Binaural audio over MADIs, the general case

Most third party equipment (e.g. RME, Lawo) treats the AES streams from a MADI interface as 32 linked pairs, A and B channel together. So in the general case, the following strategy should be used to route the AES streams for binaural audio:

In the card/port configuration screen in EHX, the panels should be defined on the odd numbered ports (taking the first port as 1) of the E-MADI card. The even numbered ports should be set to 'Panel Aux' to accommodate the second channel of audio. See Figure 6.5.

1. Set card type

2. Set alternate ports to panels

3. Set **Panel Aux** directly next to panel

Card Slot	Port Number	Port Action	Label	Description
1: MVX-A16	3.1 (33)	V 2RU Lever		V-Series 2RU Lever
2: MVX-A16	3.2 (34)	Panel Aux		Panel Aux
3: E-MADI 64/16	3.3 (35)	V 1RU Lever		V-Series 1RU Lever
4: Empty	3.4 (36)	Panel Aux		Panel Aux
5: Empty	3.5 (37)	V 1RU Lever		V-Series 1RU Lever
6: Empty	3.6 (38)	Panel Aux		Panel Aux
7: Empty	3.7 (39)	V 2RU Lever		V-Series 2RU Lever
8: Empty	3.8 (40)	Panel Aux		Panel Aux
9: Empty	3.9 (41)	Empty		
10: Empty	3.10 (42)	Empty		
11: Empty	3.11 (43)	Empty		
12: Empty	3.12 (44)	Empty		
13: Empty	3.13 (45)	Empty		
14: LMC-64	3.14 (46)	Empty		
15: Empty	3.15 (47)	Empty		
	3.16 (48)	Empty		

To configure binaural audio on V-series panels on a MADI card in EHX go to:

**EHX>Hardware>Cards and Ports.**

This example shows how to configure ports for audio streamed in pairs, A and B. Note that alternate ports have been set to accommodate paired audio streams. To enable binaural audio, set '**Panel Aux**' next to the main audio stream.

**Figure 6-5 Configuring binaural audio for third party MADI routers**

## 6.7.2 Binaural audio over Optocore/ProGrid MADIs

Optocore/ProGrid MADIs allow each channel of the MADI to be routed individually to any channel of any destination. The AES streams do not have to be routed and configured in pairs. The ProGrid equipment allows fully flexible routing and it is possible to mix close packed mono and conventional stereo pairs on one MADI interface.

It is the routing matrix in the ProGrid equipment that is used to get the main panel port to the A channel of the AES interface. Also, it is the routing matrix in the ProGrid that is used to pair the audio channels as required.

**In all cases, when using a router such as ProGrid, ensure that the configuration of the E-MADI card and the configuration of the ProGrid matrix are consistent with each other.**

For example, if ports 1,2,3,4,5,7,9,11... are defined as panels in EHX, the ProGrid must be used to ensure that the channels 1,2,3,4,5,7,9,11... are routed to and from the A channels of the AES interfaces.

## 6.8 Set the EHX Audio Mixer screen option for binaural audio routing

- 6) Select **Configuration>Panels>Audio Mixer>Layout Basic Settings** in the EHX software and chose either **Layout Binaural coax/AES** or **Layout Binaural coax/AES + D25**. See Fig. 6.6.

Select **Configuration>Panels>Audio Mixer>Layout Basic Settings>Layout Binaural coax/AES**

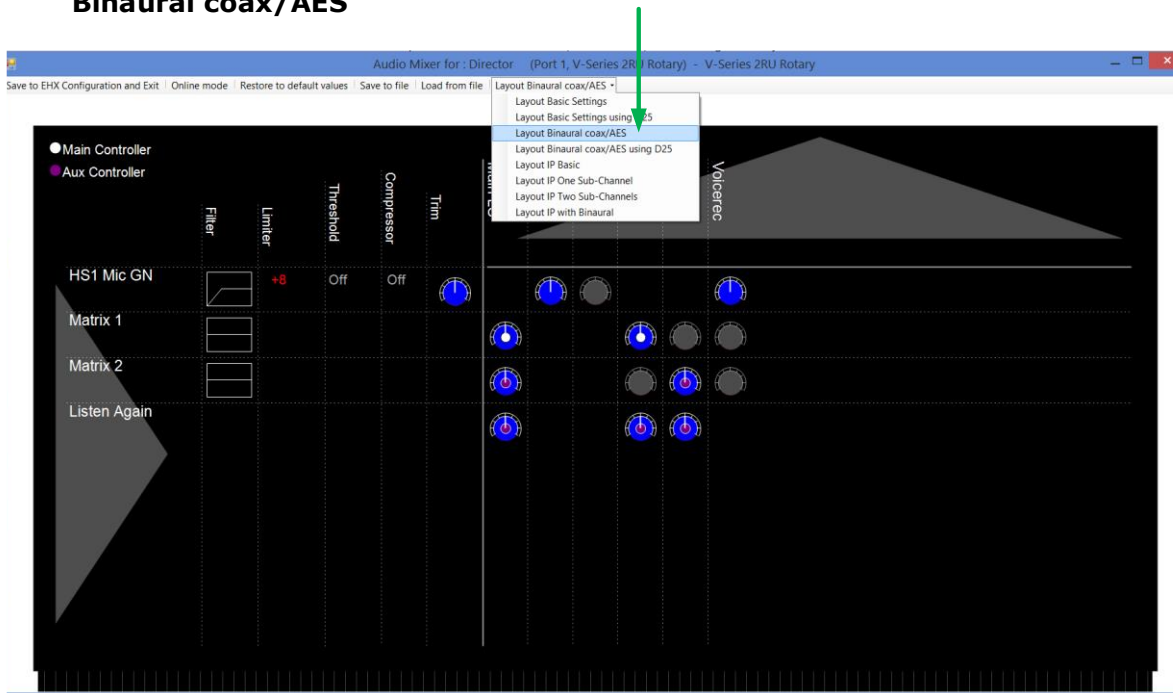

Figure 6-6 Set binaural viewing options in the audio mixer

- 7) Set audio routes as required (see ***EHX User Guide, 8. Audio Mixer*** for more information).

## 6.9 Upgrading the E-MADI64 card

The E-MADI64 card is both **centrally** upgradable (you can upgrade the E-MADI64 through the matrix, using EHX) and locally upgradeable, using Xilinx software, a PC and a Xilinx download cable.

For more information, see the ***Eclipse HX Upgrade Guide***.

## 7 **E-FIB fiber card**

---

This chapter describes how to connect Eclipse matrices using E-FIB fiber interfaces.

E-FIB fiber interfaces connect Eclipse HX matrices together to provide a high speed, dual redundant link to transfer audio samples and data between systems. These connections can be configured in various ways to provide protection against the loss of a link or a node.

Each fiber interface comprises:

- A front card with various controls and status indicators (including a reset button, status LEDs for power, processor function, card status, link status and link activity).

**Note:** The link status and activity LEDs indicate whether there is activity on a link, whether the card is transmitting on a link and the error state of a link.

- A rear card with two Duplex LC Terminated fiber optic connectors (**TXVRA** and **TXVRB**). The fiber interfaces use **9/125µ Single Mode fiber optic cables**.

The standard maximum node length is 10km but other distances are available to special order. For further details, see **15 Specifications**.

Clear-Com recommends that you fit E-FIB cards in **slots 14 and/or 15** of an Eclipse HX-Omega matrix. If fiber interfaces are fitted to any matrix in a linked system **all** the linked matrices must be reset to ensure that all matrices correctly recognize the new hardware.

**Note:** For an overview of the Eclipse HX-Omega matrix, see **3 Overview** in this guide.

## 7.1 E-FIB front panel lights and controls

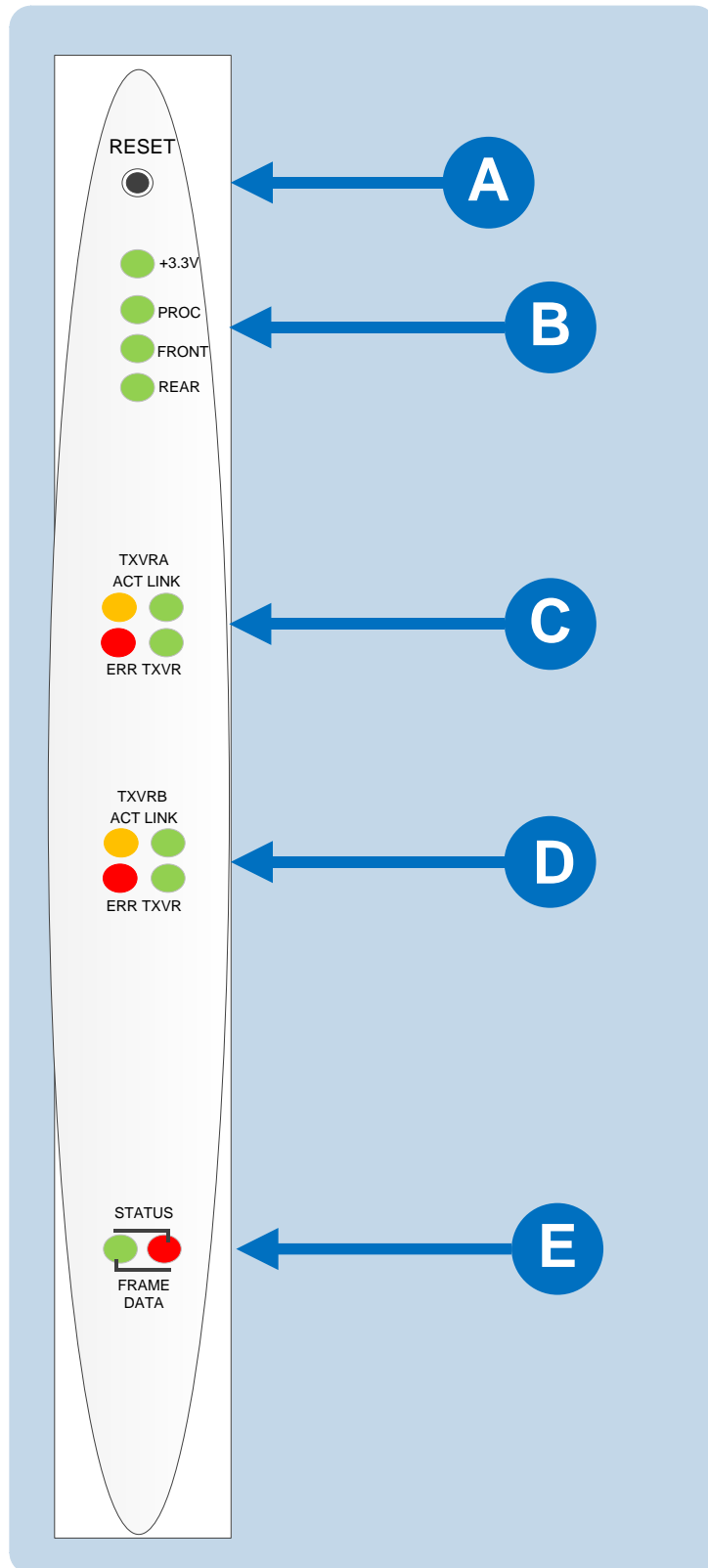

Figure 7-1: E-FIB front panel lights and controls

Key to Figure 22: E-FIB front panel lights and controls	
Feature	Description
<b>A</b>	<p><b>RESET button</b></p> <p>Pressing the <b>RESET button</b> causes the card and all links to momentarily stop their current activity and to restart. The card's <b>matrix data</b> light goes off when the reset starts and comes back on when the reset is complete.</p> <p>During the reset, configuration information downloads to the card and its connected matrices from the CPU card. If the entire system is operating except for one fiber card press the reset button for that card only.</p> <p><b>Tip:</b> <i>The reset button is slightly recessed from the front panel to prevent it from being accidentally pressed. A tool such as a bent paper clip is needed to press this button.</i></p>
<b>B</b>	<p><b>Power supply and Status lights</b></p> <p><b>+3.3-Volt Power Supply LED</b></p> <p>The matrix's +3.3-volt power supply provides electric current to this <b>green</b> LED. When lit, the light indicates that the +3.3-volt supply is present and supplying electric current to the card.</p> <p><b>Processor LED</b></p> <p>When lit, this <b>green</b> LED indicates that the fiber card on-board processor is running</p> <p><b>Front Card LED</b></p> <p>When lit, this <b>green</b> LED indicates that the front card is functioning normally.</p> <p><b>Rear Card LED</b></p> <p>When lit, this <b>green</b> LED indicates that the rear card is functioning normally.</p>
<b>C</b>	<p><b>Primary Link Status LEDs</b></p> <p>These LEDs indicate the status and functioning of the primary (A) fiber optic link.</p> <p><b>ACT LED</b></p> <p>When lit, this <b>yellow</b> LED indicates that the primary fiber optic circuit is active.</p> <p><b>Link LED</b></p> <p>When lit, this <b>green</b> LED indicates whether a link has been established on the primary fiber optic circuit (transceiver A). When illuminated a link is present.</p> <p><b>ERR LED</b></p>

	<p>When lit, this <b>red</b> LED indicates that an error condition has been detected on the primary fiber optic circuit.</p> <p><b>TXVR LED</b></p> <p>When lit, this <b>green</b> LED indicates when data is being transmitted on the primary circuit. It is illuminated when data is present on the circuit.</p>
<b>D</b>	<p><b>Secondary Link Status LEDs</b></p> <p>These LEDs indicate the status and functioning of the secondary (B) fiber optic link.</p> <p><b>ACT LED</b></p> <p>When lit, this <b>yellow</b> LED indicates that the secondary fiber optic circuit is active.</p> <p><b>Link LED</b></p> <p>When lit, this <b>green</b> LED indicates whether a link has been established on the secondary fiber optic circuit (transceiver B). When illuminated a link is present.</p> <p><b>ERR LED</b></p> <p>When lit, this <b>red</b> LED indicates that an error condition has been detected on the secondary fiber optic circuit.</p> <p><b>TXVR LED</b></p> <p>When lit, this <b>green</b> LED indicates when data is being transmitted on the secondary circuit. It is illuminated when data is present on the circuit.</p>
<b>E</b>	<p><b>Status LED</b></p> <p>The <b>Status LED</b> illuminates <b>solid red</b> when there is a communications failure between the fiber card and the CPU card.</p> <p><b>Matrix Data LED</b></p> <p>The <b>Matrix data LED</b> <b>flashes green</b> to indicate successful communication between the fiber master card and the CPU card.</p>

Table 7-1: E-FIB front panel lights and controls

## 7.2 E-FIB rear panel lights and connectors

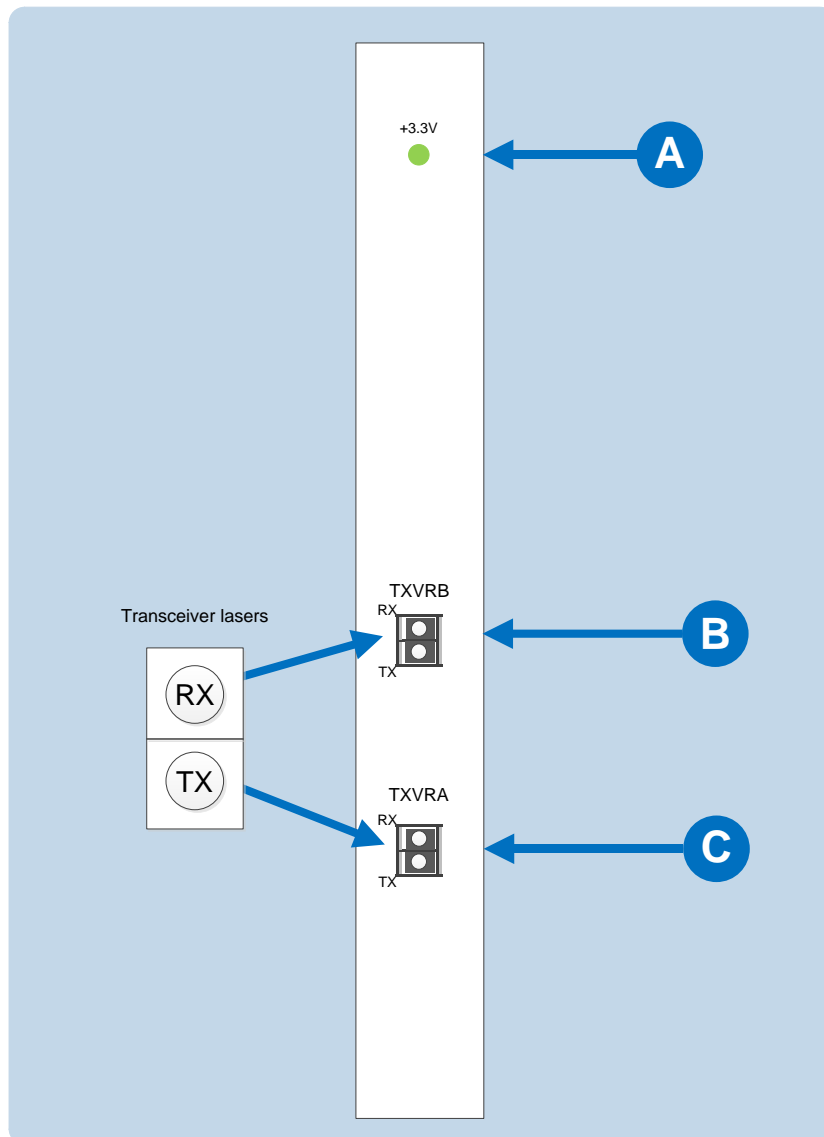

Figure 7-2: E-FIB rear panel lights and connectors

### **Warning: Eye Safety**

**This laser based single mode transceiver is a Class 1 Laser product.** It complies with IEC 60825-1/A2:2001 and FDA performance standards for laser products (21 CFR 1040.10 and 1040.11) except for deviations pursuant to Laser Notice 50, dated July 26, 2001.

Normally a protective plug is fitted to the fiber connector to protect the connector from damage or the entry of foreign materials. The protective plug should only be removed in order to fit the fiber optic cable. Replace the plug when the cable is unplugged.

Primary and secondary fiber ports are reversed with respect to the front panel indicators.

Care should be taken when connecting or disconnecting cables to ensure that they are connected correctly and not reversed.



Key to Figure 25: E-FIB rear panel connectors	
Feature	Description
	<b>+3.3-Volt Power Supply LED</b> When this <b>green</b> LED is lit, the +3.3-volt power supply (supplied by the matrix) is present and supplying electric current to the card.
	<b>Fiber transceiver with Duplex LC type connector.</b> The <b>TXVRB</b> connector is used for the secondary ring.
	<b>Fiber transceiver with Duplex LC type connector.</b> The <b>TXVRA</b> connector is used for the main ring.

Table 7-2: Key to Figure 23: E-MADI64 rear panel connectors

The fiber optic cable for the primary and secondary circuits are plugged into the appropriate ports. An example showing three systems configured with a primary and secondary ring is shown in **Figure 7-3: Primary and redundant ring configuration**.

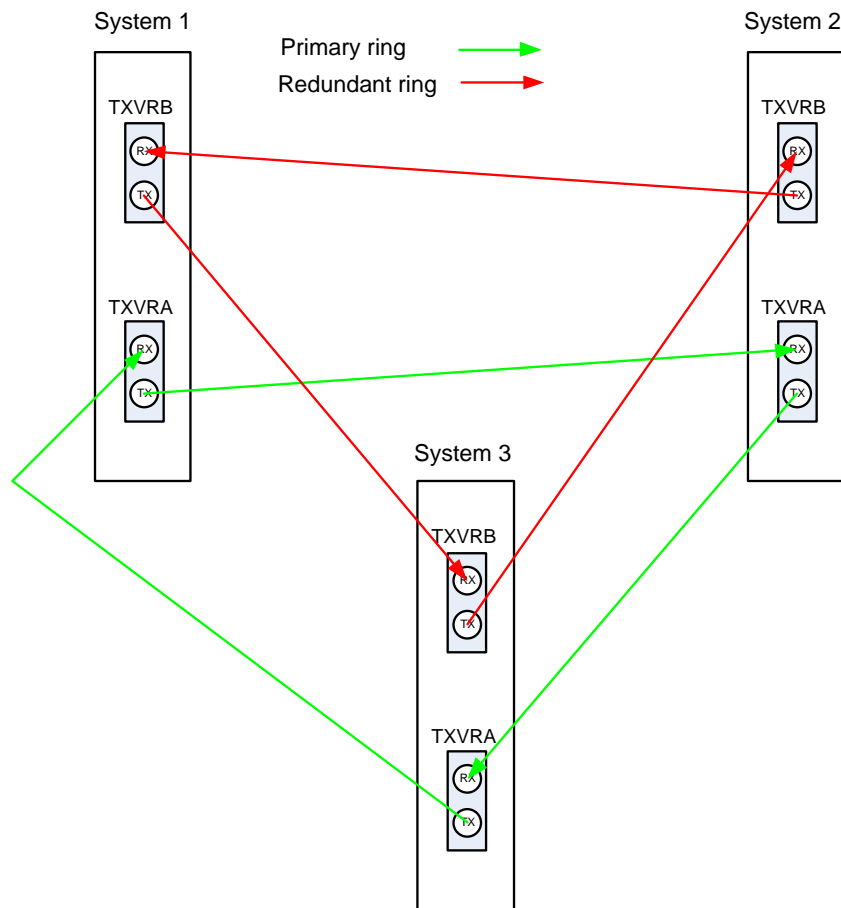

Figure 7-3: Primary and redundant ring configuration

## 7.3 Configuring a fiber optic connection

There are a number of ways that optical connections can be made between systems depending on the level of redundancy required.

When a break occurs in the fiber ring, a solid red status light will be shown at the fiber card downstream from the break and the link status LEDs may show **amber**. Other fiber cards will intermittently show **red**, as the ring attempts to recover. If the system layout is displayed by EHX the faulty links are shown in red.

In order to diagnose faults or switch between primary and secondary rings or between primary and backup fiber linking cards the **system monitoring screen** in EHX must be used.

**Note:** For more information about EHX, see your EHX documentation (including **EHX Help**).

## 7.4 Simplex fiber cabling

### 7.4.1 Single card set redundancy

In this scenario, each matrix contains one fiber-optic Linking card set (see **Figure 7-4: Ring topology: single card set redundancy** ).

This approach still affords fiber connection redundancy since each rear card houses two fiber-optic transceivers.

**Note:** In the absence of an **Uninterrupted Power Supply (UPS)**, this configuration will **not** protect against loss of the node or the matrix itself.

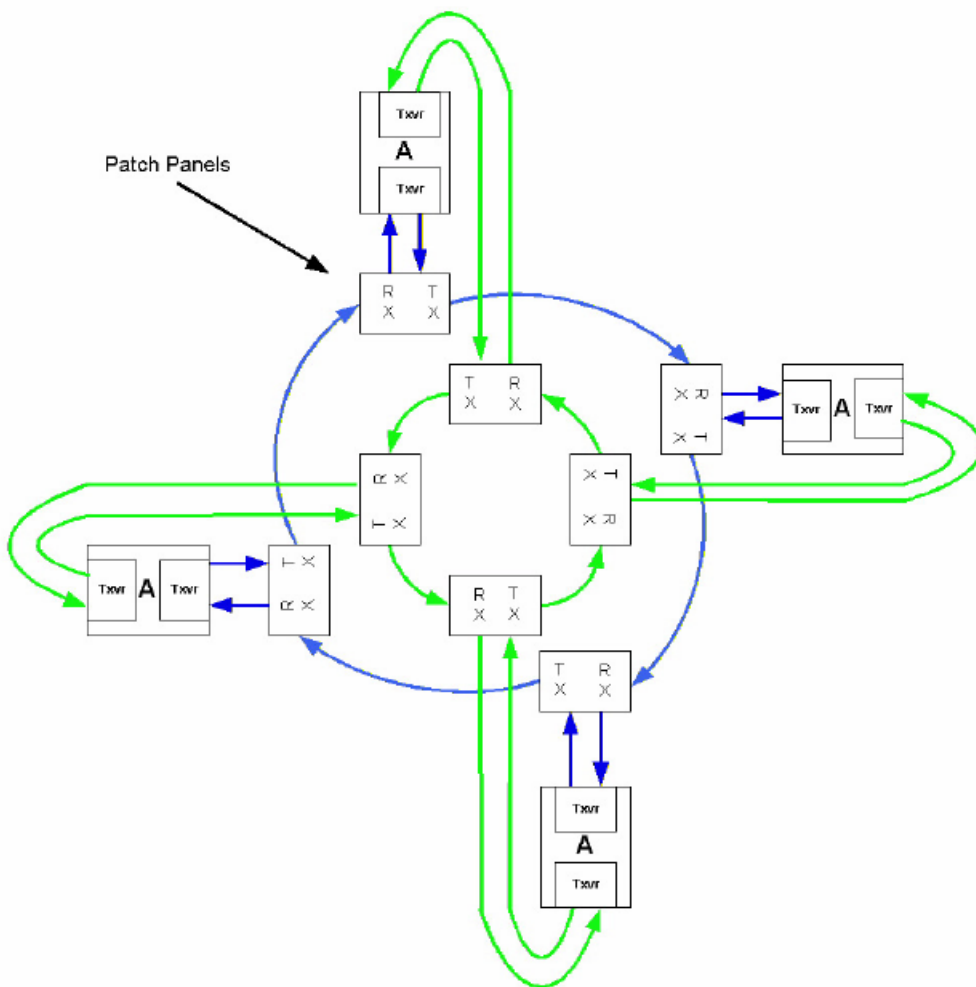

Figure 7-4: Ring topology: single card set redundancy

#### Loss of single fiber connection

When there is no break in the fiber connections the fiber audio will be routed using the primary ring.

If there is any connection failure on the primary ring and the secondary ring is intact then the fiber audio routing will move to the secondary ring.

The self-healing mechanism is performed automatically by the **Fiber Linking Card**.

Switching to the secondary ring will cause audio breaks or disturbances and momentary loss of crosspoint data.

If a single fiber connection is lost on both rings the nodes adjacent to the failures will loop-back their connections to the failed cables healing the rings. In the state the fiber audio will therefore be routed utilizing both the primary and secondary fiber rings.

**Note:** The configuration software (EHX) will report any failures in the fiber connection system.

#### **Loss of a single node**

If a node is lost on the ring the nodes adjacent to the failed node will loop-back their connections to the failed node healing the ring using the working remains of the ring. The configuration software (EHX) will report the failure.

This applies to the situation where the fiber card itself has failed rather than the matrix.

#### **Loss of two fiber connections**

If two adjacent fiber connections are lost on the ring, this will be handled as for the loss of a single node where the nodes adjacent to the failed node will loop-back their connections to the failed node healing the ring.

The configuration software will report the failure correctly as two failed cables. If two non-adjacent fiber connections are lost on the ring the nodes adjacent to the failures will loop-back their connections to the failed cables healing the ring into 2 separate smaller rings. The configuration software will report the failure.

**Note:** In this instance the two sub-rings will be dependent on their Ethernet connections for configuration and data transmission but there will be no audio path between them.

#### **Loss of two nodes**

If two adjacent nodes are lost on the ring this will be handled as for the loss of a single node where the nodes adjacent to the failed node will loop-back their connections to the failed nodes healing the ring. The configuration software will report the failure correctly as two failed nodes.

If two non-adjacent nodes are lost on the ring the nodes adjacent to the failures will loop-back their connections to the failed nodes healing the ring into 2 separate smaller rings. The configuration software (EHX) will report the failure.

**Note:** In this instance the two sub-rings will be dependent on their Ethernet connections for configuration and data transmission but there will be no audio path between them.

## 7.4.2 Dual card set redundancy

The fiber linking function supports Dual card set redundancy. Both **Card set A** and **Card set B** are fitted in each node of the ring. In this case each matrix contains two **Fiber-optic Linking card sets**.

This approach affords full redundancy, offering protection against component failure within a single Fiber-optic Linking Card Set

### Parallel operation

The cabling and operation of both cards sets is the same as described in **7.4.1 Single card set redundancy**.

All card set A units in the linked set are networked together forming a redundant fiber ring. However additionally all card set B units are additionally networked together to form a parallel redundant fiber ring. There is no fiber linkage between these two parallel fiber networks.

During normal operation each matrix monitors the number of nodes that are reachable on each of the two fiber networks. When there is parity between card set A and card set B then card set A will be used to route audio to and from the matrix.

### Loss of fiber connections and nodes

As long all nodes are still deemed to be reachable on Card set A no switchover will be performed to Card set B.

Therefore, even if fiber connection issues on Card set A that a) result in a switch to the secondary ring (on Card set A) or b) result in a switch to loopback mode then Card set A will continue to be used to route audio to and from the matrix.

If sufficient fiber errors occur (either cabling or card failures) that result in the number of reachable nodes on Card set A dropping below that of Card set B then the matrix will switch to Card set B.

The currently active fiber card can be identified as it will flash its green status LED. The current backup (in active) fiber card will not illuminate its green status LED.

### 7.4.3 Fault tolerance

In all fault cases involving recoverable cable faults or loss of nodes on one or both rings the remaining nodes may experience audio breaks or disturbances and temporary loss of crosspoint information or data.

Audio and data from a failed node will not be available to the remaining nodes for the duration of the failure. When a ring with non-adjacent failures sub-divides into two sub-rings, audio and data from the failed nodes will **not** be available to the nodes in either sub-ring.

Audio and data will continue to be available to nodes within the same sub-ring but data may still be available to all nodes that are still functioning if there is an intact, independent Ethernet connection to those nodes.

If an Eclipse HX-Omega, connected as a node of the fiber-optic link is reset, powered down or failed this will constitute a lost or failed node on both rings and this node will experience audio breaks or disturbances and loss of crosspoint information or data for up to 5 seconds after the fault condition is cleared or repaired.

#### **Single Card Set Redundant System: fiber redundancy**

In all fault cases involving cable faults or loss of nodes on the ring the remaining nodes may experience audio breaks or disturbances and loss of crosspoint information or data.

When a ring with non-adjacent failures sub-divides into two sub-rings, audio and data from the failed nodes will not be available to the nodes in either sub-ring, audio and data will continue to be available to nodes within the same sub-ring but data may still be available to all nodes that are still functioning if there is an intact, independent Ethernet connection to those nodes.

If a matrix, connected as a node of the fiber-optic link is reset, powered down or failed this will constitute a lost or failed node on the ring and this node will experience audio breaks or disturbances and loss of crosspoint information or data for up to 5 seconds after the fault condition is cleared or repaired.

An example of how a system with multiple matrices would be wired together is shown in **Figure 7-5: Example fiber-optic connection setup...**

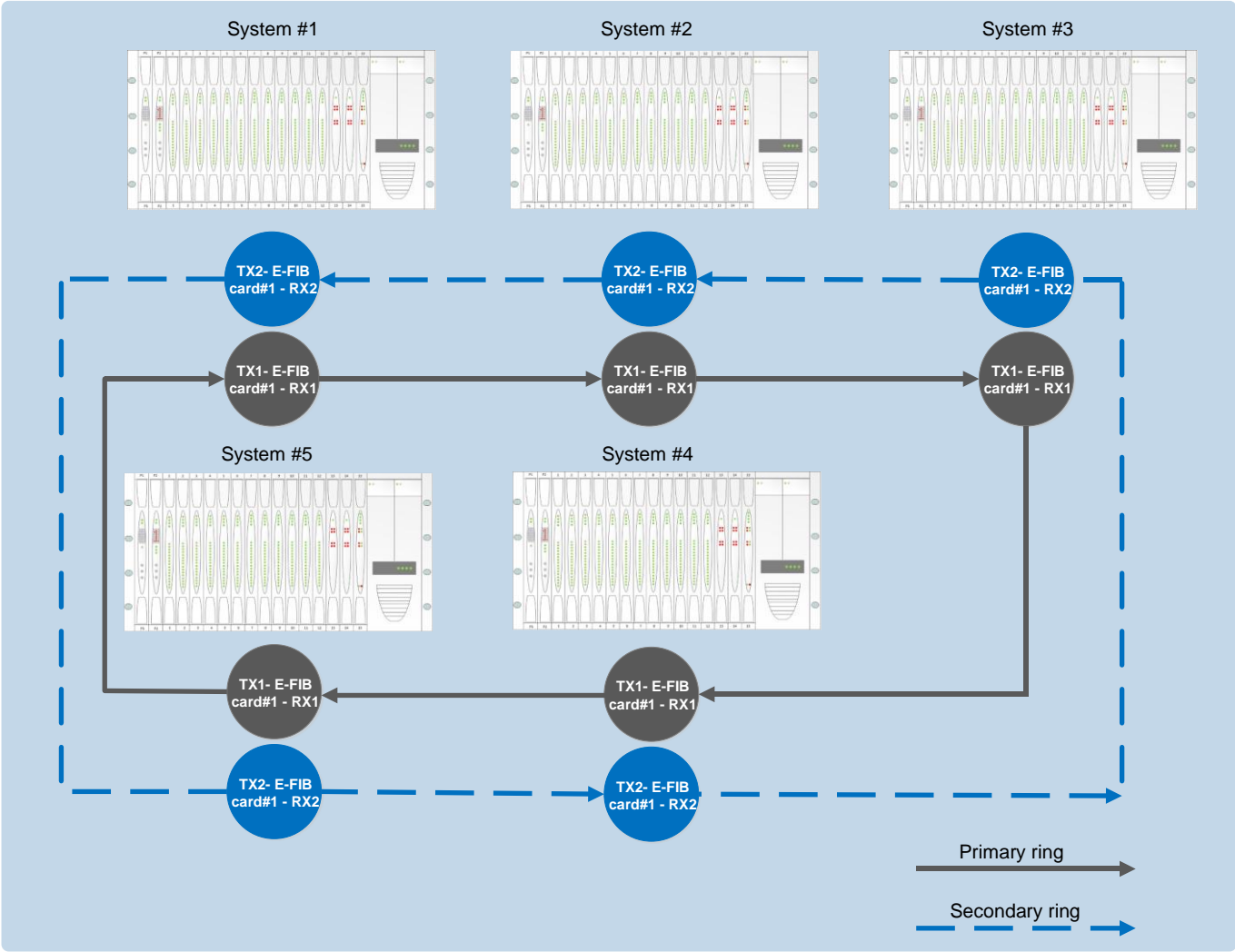

Figure 7-5: Example fiber-optic connection setup



## 8 E-Que E1 / T1 card

---

The E-Que interface card allows you to connect the Eclipse HX-Omega to **FreeSpeak/CellCom/FreeSpeak II** antennas and antenna splitters, **E1** and **T1** trunk lines and **E1** direct lines. Each E-Que interface card comprises:

- A front card with a reset button and various status indicators (LEDs for power, port activity and LAN status).

**Note:** The port activity LEDs indicate whether there is a device connected to an E1 port and that a connection has been established between the E1 port and the connected device.

- A rear card with eleven RJ45 ports giving eight standard ports, DECT sync in and out and a LAN port.

A total of four E-Que, IVC-32 or LMC-64 interface cards may be fitted to an Eclipse HX-Omega unless the matrix is fitted with a Power-One PSU. If the matrix has a Power-One PSU, up to six E-Que, IVC-32 or LMC-64 cards may be fitted with the following condition:

- You can only have four wireless E-Que cards
- You can only have four E-Que cards with EM signaling enabled.

**Note:** You do **not** require an Ethernet cable connected to the E-Que card LAN port for the card to function correctly.

**Note:** For an overview of the Eclipse HX-Omega matrix, see **3 Overview** in this guide.

### 8.1 Supported FreeSpeak / CellCom / FreeSpeak II connection options

The FreeSpeak/CellCom/ FreeSpeak II connection options supported are:

- Up to 8 x FreeSpeak/CellCom/ FreeSpeak II antenna direct connections per E-Que interface.
- Up to 2 x FreeSpeak/CellCom/ FreeSpeak II splitter connections (up to 5 antennas each) per E-Que interface.

Using all four wireless E-Que interface cards that can be fitted (the maximum number) would allow up to 40 antennas and 200 belt packs to be connected to a matrix.

## 8.2 Supported direct and trunk connections (using the E1 and T1 protocols)

The E-Que interface card also provides facilities for direct and trunk connections using the E1 protocol, and trunk connections over T1 protocol. There are:

- **30 audio channels** on each of 2 connectors (60 channels in total) available in **E1** mode.
- **24 audio channels** on each of 2 connectors (48 channels per card in total) are available in **T1** mode.

## 8.3 E-Que front panel lights and controls

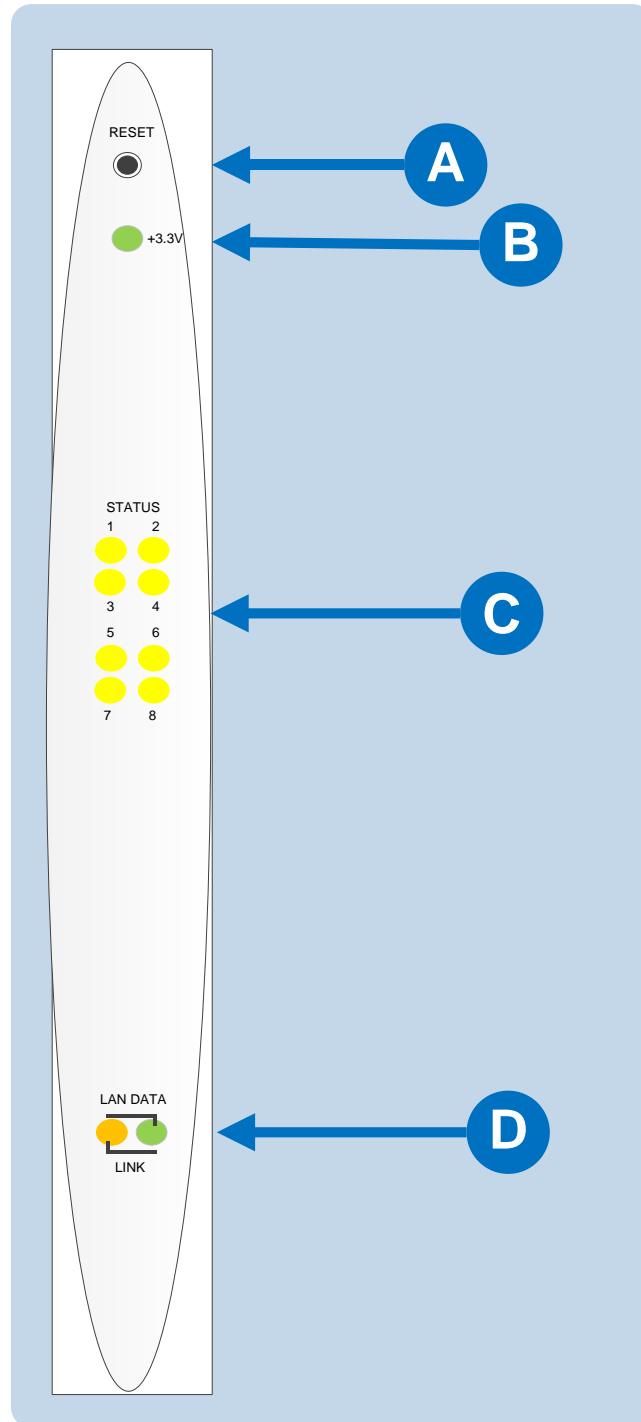

Figure 8-1: E-Que front panel lights and controls

Key to Figure 30: E-Que front panel lights and controls	
Feature	Description
<b>A</b>	<p><b>RESET button</b></p> <p>Pressing the reset button causes the card and all links to momentarily stop their current activity and to restart.</p> <p>During the reset, configuration information downloads to the card from the CPU card. If the entire system is operating except for one E-Que card press the reset button for that card only.</p> <p><b>Tip:</b> <i>The reset button is slightly recessed from the front panel to prevent it from being accidentally pressed. A tool such as a bent paper clip is required to press this button.</i></p>
<b>B</b>	<p><b>Power supply lights</b></p> <p><b>+3.3-Volt Power Supply Light</b></p> <p>The matrix's +3.3-volt power supply provides electric current to this green light. When lit, the light indicates that the +3.3-volt supply is present and supplying power to the card.</p>
<b>C</b>	<p><b>Status lights</b></p> <p>When lit, a <b>status light</b> indicates successful communication between the E-Que card and a connected device such as an active antenna or splitter.</p> <p>Each of the E-Que card's 8 <b>yellow status lights</b> corresponds to one of 8 ports to which devices can be connected.</p>
<b>D</b>	<p><b>LAN DATA</b></p> <p>The <b>green LAN DATA</b> light illuminates to indicate there is data passing through the Ethernet port.</p> <p><b>LAN LINK</b></p> <p>The <b>amber LAN LINK</b> light illuminates to indicate a connection to the LAN port.</p>

Table 8-1: Key to E-Que front panel lights and controls

## 8.4 E-Que rear panel connectors

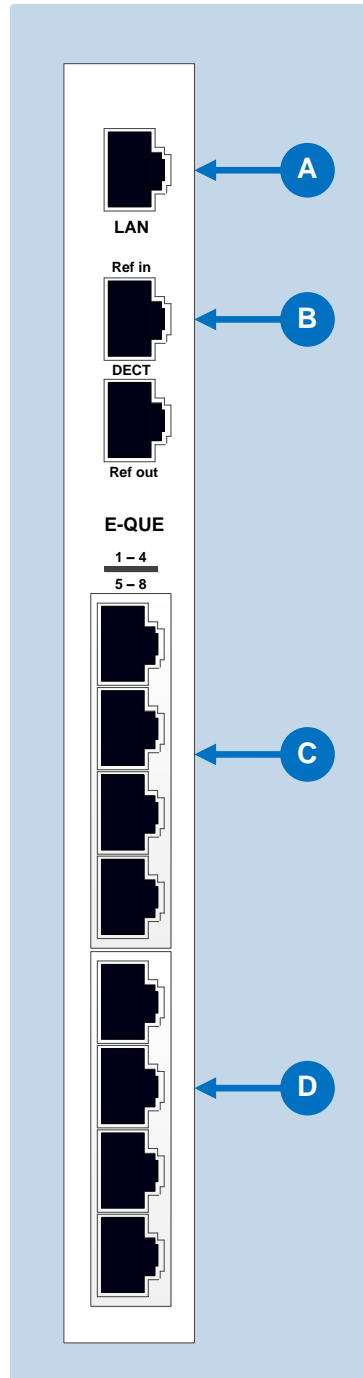

Figure 8-2: E-Que rear panel connectors

<b>Key to Figure 32: E-Que rear panel connectors</b>	
<b>Feature</b>	<b>Description</b>
<b>A</b>	<b>LAN port (RJ-45)</b> The LAN port is used for diagnostic purposes.
<b>B</b>	DECT sync ports: <b>DECT Ref in</b> <b>DECT Ref out</b>
<b>C</b>	<b>E1 / T1 Port 1 (RJ-45)</b> <b>E1 / T1 Port 2 (RJ-45)</b> <b>E1 / T1 Port 3 (RJ-45)</b> <b>E1 / T1 Port 4 (RJ-45)</b>
<b>D</b>	<b>E1 / T1 Port 5 (RJ-45)</b> <b>E1 / T1 Port 6 (RJ-45)</b> <b>E1 / T1 Port 7 (RJ-45)</b> <b>E1 / T1 Port 8 (RJ-45)</b>

Table 8-2: Key to E-Que rear panel connectors

## 8.5 Synchronization

When multiple E-Que cards are fitted in a rack, one of the cards generates a clock signal, which all other cards lock to, to ensure that all antennas remain in sync. The system is designed such that the leftmost card (seen from the front) is always the one which generates this signal.

This means that if the leftmost card is removed, or a new card is fitted to the left of existing cards, the antennas will lose lock for a few seconds as the cards re-configure themselves and a new card starts generating the sync signal.

Where multiple connected matrices are used containing E-Que cards the DECT reference ports are connected as a daisy chain between the matrices to ensure that the DECT signals are synchronized through all the E-Que cards present in the matrices. Failure to connect the DECT sync signal between matrices will result in poor utilization of the DECT bandwidth, and the system may operate poorly in a congested RF environment.

**Note:** The LAN port is used for diagnostic purposes.

## 8.6 E-Que interface applications

The E-Que interface may be used to connect:

- FreeSpeak/CellCom/FreeSpeak II antennas and splitters to an Eclipse HX-Omega matrix.
- Provide E1 and T1 connections to other systems.

**Note:** For more information about E1 and T1 cable pinouts and cable connections, see:

- **4.10 E1/T1 Matrix to Matrix straight cable connections.**
- **4.11 E1 to FreeSpeak® / CellCom® / FreeSpeak II™ antenna straight cable connection.**

### 8.6.1 FreeSpeak/CellCom/FreeSpeak II application

The E-Que interface cards can be configured for FreeSpeak/CellCom/FreeSpeak II use in two modes, depending on whether antennas or splitters are to be connected.

If the E-Que interface card is configured:

- In **antenna** mode all eight E1/T1 ports can be used to connect up to eight antennas.
- To support **splitters**, only two ports are active (ports 1 and 5), allowing a maximum of two splitters to be connected. Each splitter can support up to five antennas.

When the E-Que interface cards are used in FreeSpeak/CellCom/FreeSpeak II mode, they cannot be connected to the antennas using either third party equipment or fiber. The DECT sync signal required by the antennas will not be converted by third party equipment or fiber interface cards.

Three connections schemes are illustrated below.

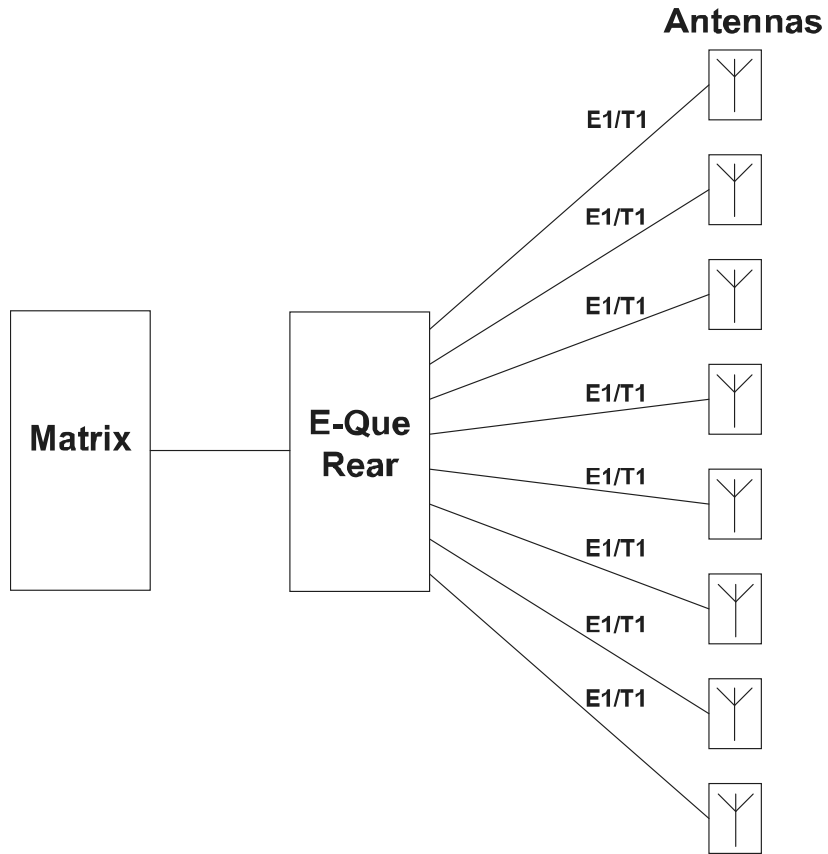
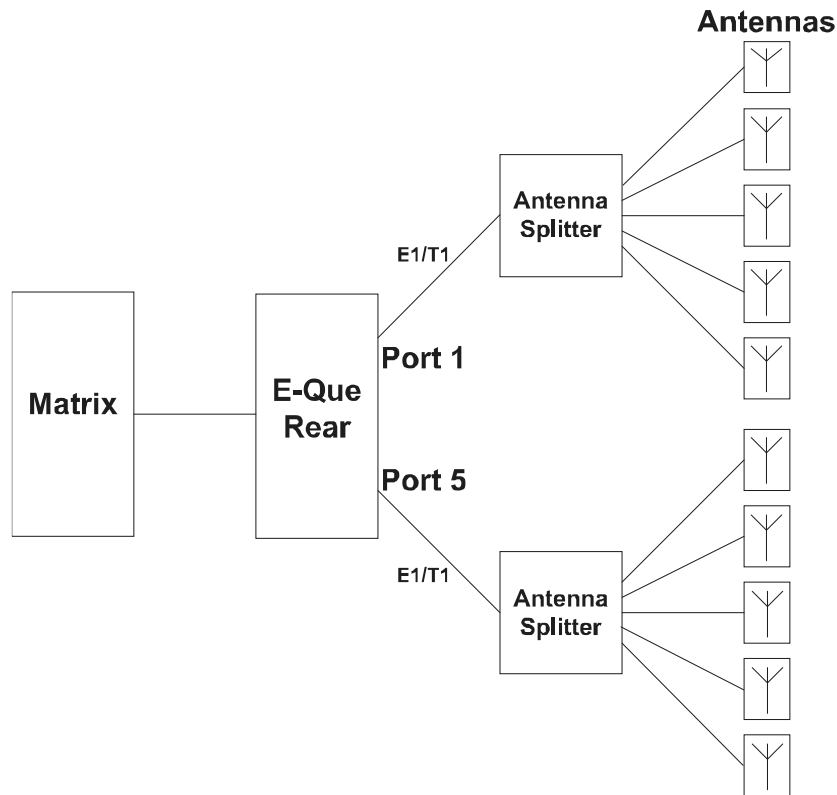

Figure 8-3: E-Que card antenna connection



**Figure 8-4: E-Que card splitter connection**

Each antenna can handle up to five beltpacks simultaneously and switch service between antennas under control of the matrix as the beltpack user moves around the site.

### 8.6.2 Powering the transceiver / antenna

The DC In power connector is used to locally power the transceiver/antenna with the supplied universal power supply. Use of local power is always required when the transceiver/antenna is connected directly to the E-Que rear card (rather than via a splitter), and may be required if the antenna is located more than 300 meters (925 feet) from a splitter. It is recommended even when the transceiver/antenna is closer whenever it is available and convenient.

### 8.6.3 Locating the transceiver / antenna

Transceiver/antennas can be located up to 1,000 meters (3,200 feet) using 24 AWG cable or up to 500 meters (1,600 feet) using 26 AWG cable over CAT-5 cable from the base station avoiding expensive RF cable.

**Note:** It is recommended that shielded CAT-5 cable is used for all wireless installations.

## 8.6.4 DECT Sync connections

To ensure the correct operation of the FreeSpeak / CellCom / FreeSpeak II system, DECT Sync links should be established between matrices where:

- Multiple matrices are networked together with antennas.
- Splitters are connected to E-Que interface cards on more than one matrix.

Multiple E-Que interface cards within a single matrix do **not** require external DECT sync cables, connected as the signal uses the backplane.

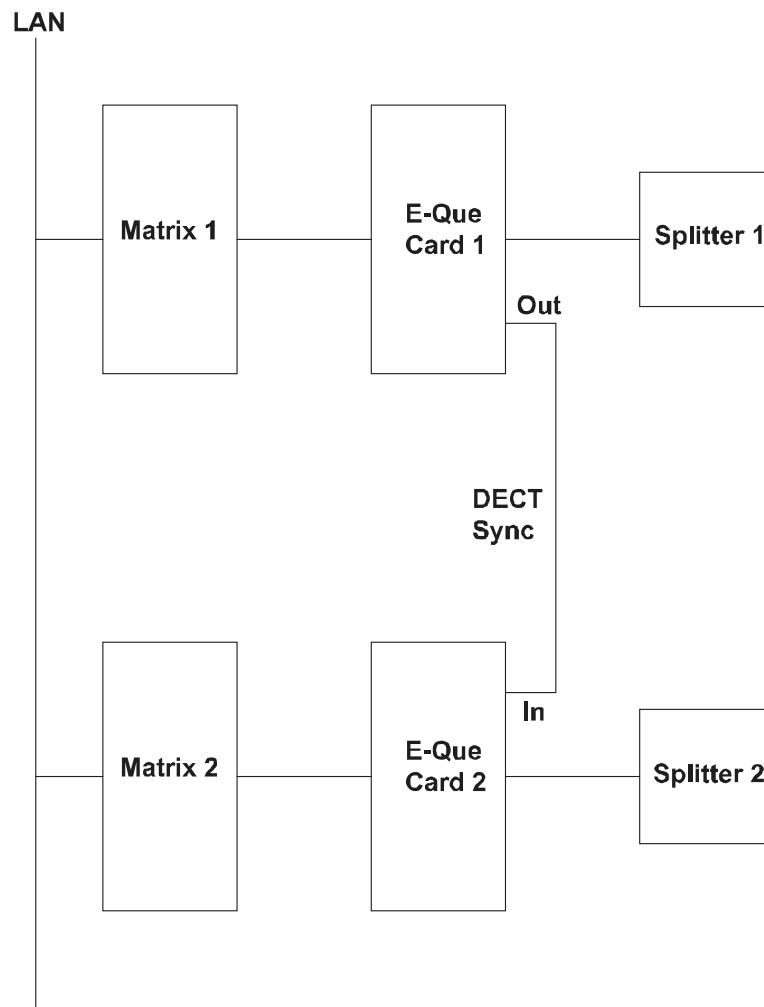

Figure 8-5: Multiple matrices with DECT Sync Interconnect

**Note:** All connections are made using CAT-5 cable and it is recommended that shielded cable is used.

**Note:** If an E-Que interface is fitted in the matrix with antennae or splitters connected and active inserting a second E-Que interface to the left of the first interface (seen from the front) will cause a temporary loss of audio to beltacks using the original E-Que interface (usually for about 10 seconds). The beltacks do not go offline and signalization is not lost.

## 8.7 E1 Trunk and Direct Modes

The E-Que interface card can be used for both direct E1 to E1 port connections or to provide trunk linking via a network between systems. The E1 connections can be made between Eclipse HX systems or between Eclipse HX systems and compatible third-party equipment. E1 mode provides 30 channels of G.711 or G.722 encoded audio available on each of ports 1 and 5, giving 60 channels per card.

The **E1 specifications** are:

- HDB3 Encoding.
- Long Haul Receive Signal Level.
- E1 120 Ohm Transmit Pulse Amplitude.
- Balanced.
- 120 Ohm Line Impedance.
- No Signaling.
- G.711 or G.722 64 kbit/s Audio Encoding.
- Tx Clock locally generated.
- Rx Clock Line Recovered.

**Figure 8-6: Matrix to Matrix direct E1 Trunking** shows E1 trunking using a direct connection between the matrices using a CAT-5 crossover cable. The E-Que interface should be set to **E1 Direct** in EHX hardware setup.

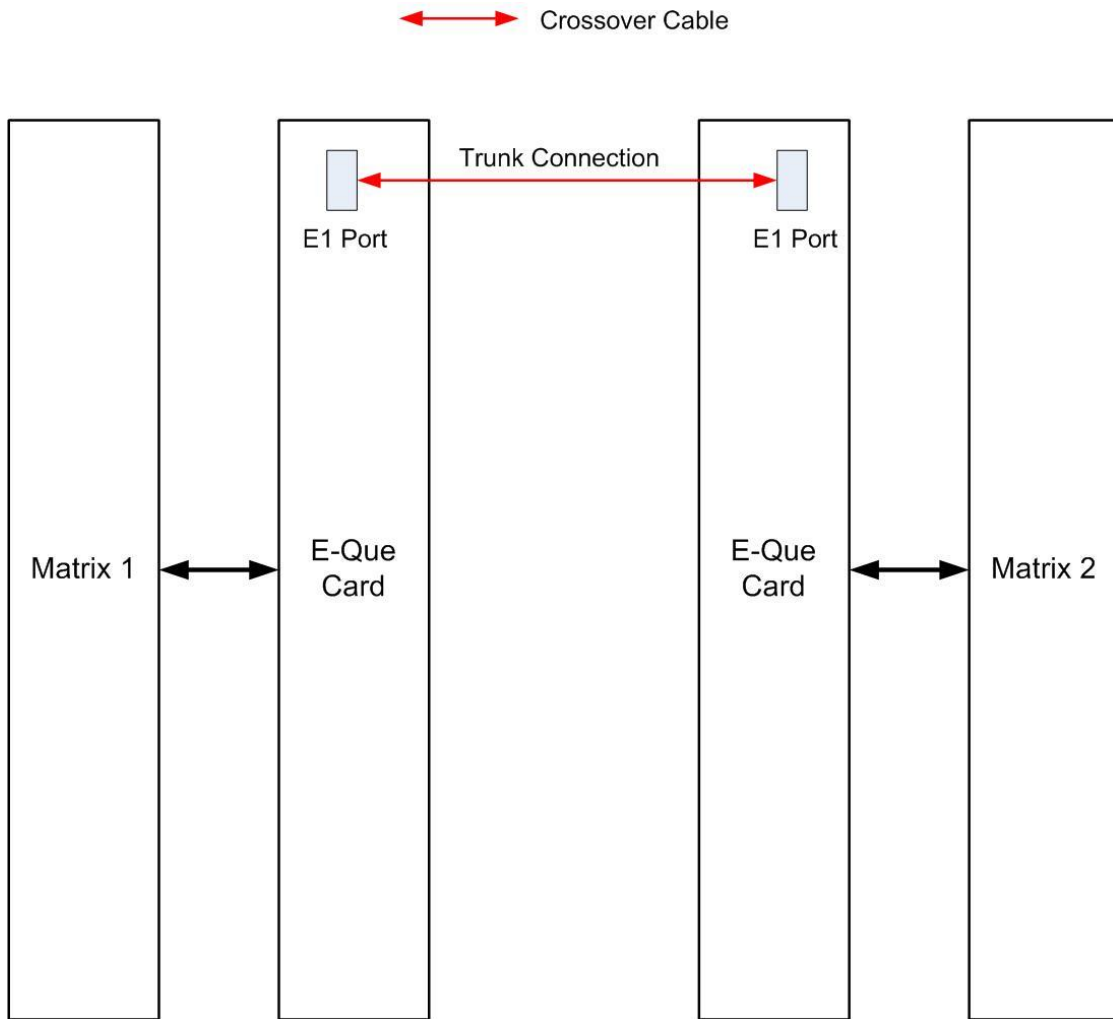

**Figure 8-6: Matrix to Matrix direct E1 Trunking**

E1 trunking between matrices can also be achieved over an E1 network, as shown **Figure 8-7: E1 Trunking with an E1 Network**.

In this case E1 ports 1 and 5 of the E-Que interface are connected using standard straight-through CAT-5 cables rather than crossover CAT-5 cables.

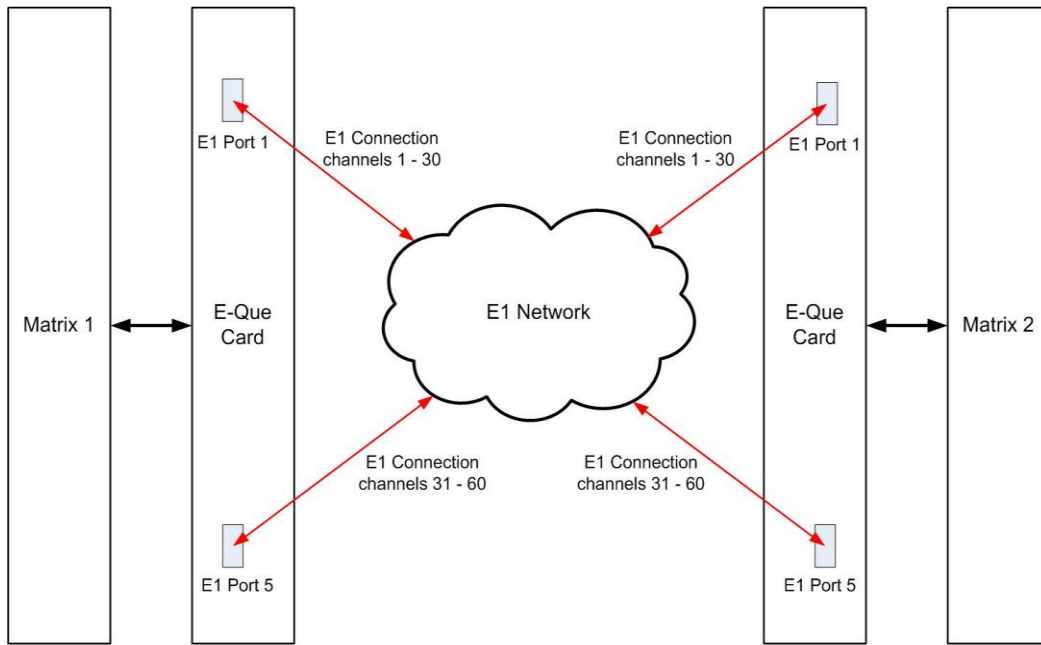

**Figure 8-7: E1 Trunking with an E1 Network**

The E-Que interface can also be used to connect the matrix to third party equipment using E1 port 1 or 5.

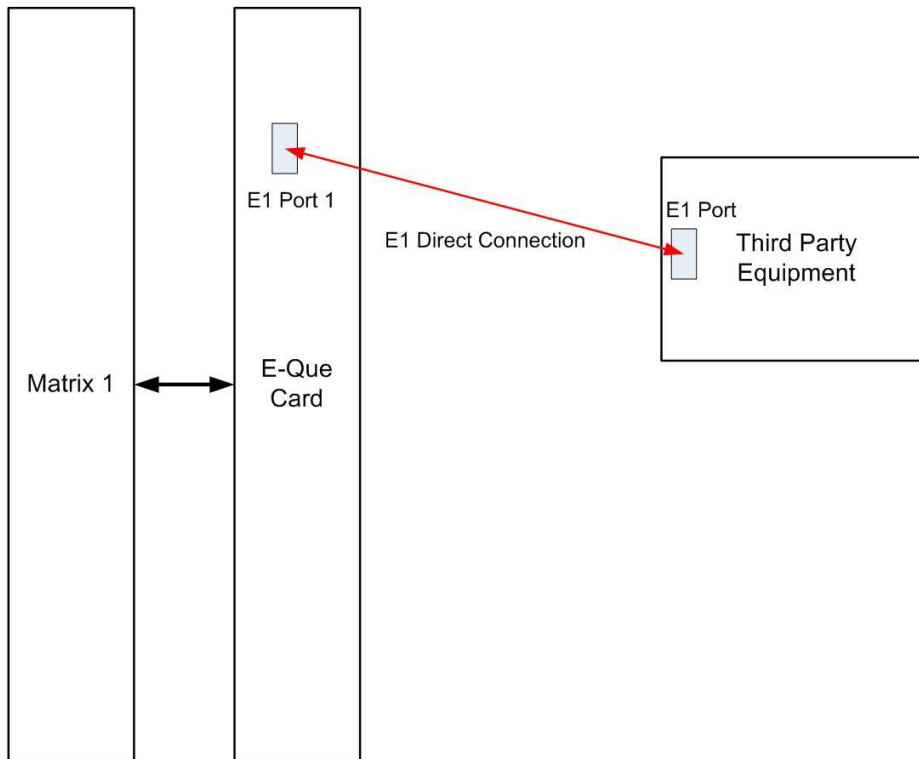

**Figure 8-8: Matrix to Third Party E1 connection**

The CAT-5 cable connecting the E1 port on the E-Que rear card may be a crossover cable or a straight-through cable depending on the requirements of the third party equipment. The E-Que interface should be set to **Direct** in EHX.

## 8.8 T1 Trunking

The E-Que interface card can provide T1 trunking between Eclipse HX systems and between Eclipse HX systems and compatible third-party equipment.

T1 mode provides 24 channels of G.722 encoded audio are available on each of ports 1 and 5, giving 48 channels per card.

The T1 trunking specifications are:

- B8ZS Encoding.
- Extended Super Frame.
- Long Haul Receive Signal Level.
- T1 Long Haul (LBO 0 dB) Transmit Pulse Amplitude.
- Balanced.
- 120 Ohm Line Impedance.

- No Signaling.
- G.722 64 kbit/s Audio Encoding.
- Tx Clock locally generated.
- Rx Clock Line Recovered.

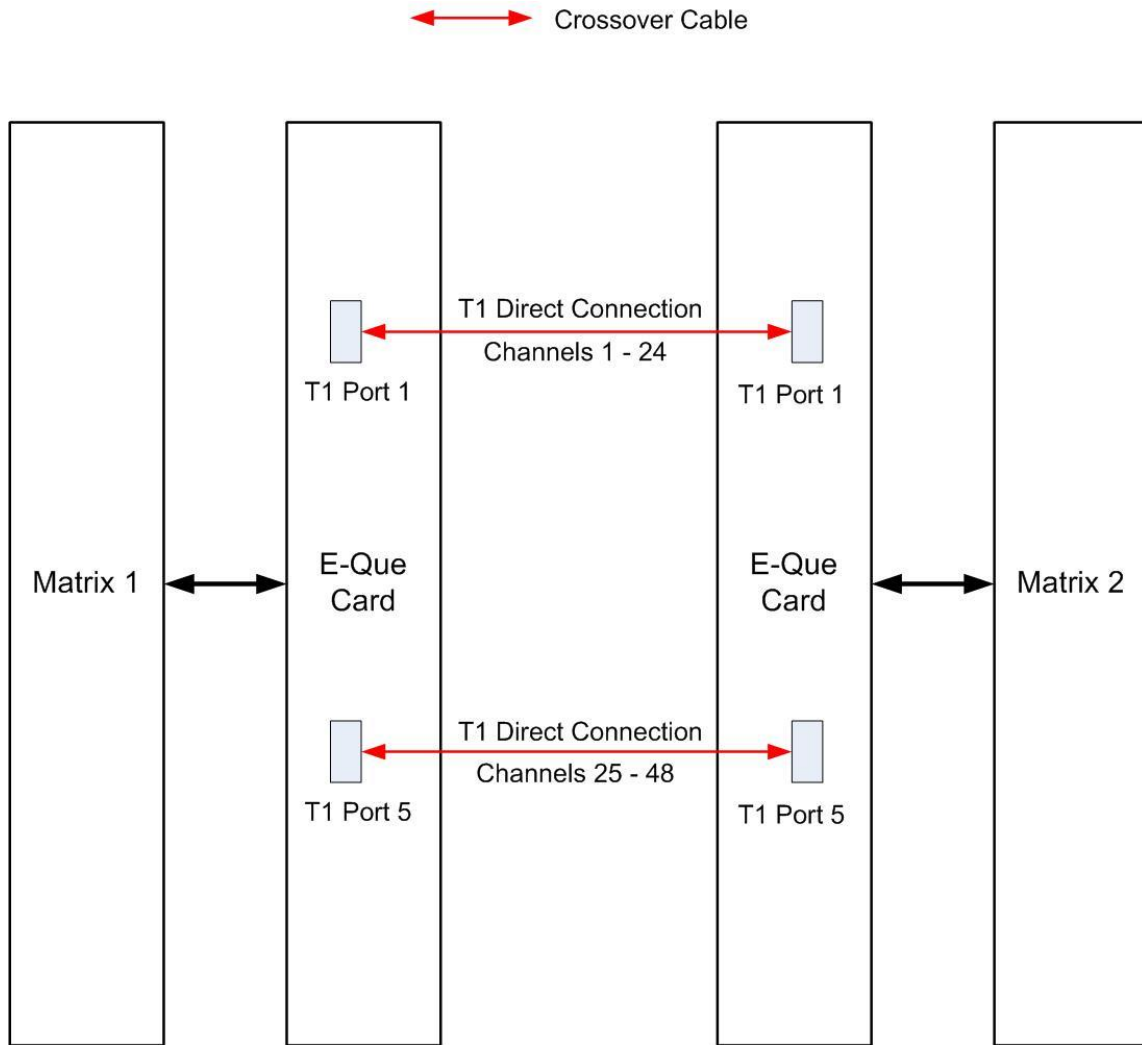

**Figure 8-9: Matrix to Matrix T1 Trunking**

T1 trunking between matrices can also be achieved over an E1 network as shown in **Figure 8-10: T1 Trunking using an E1 Network**. In this case T1 ports 1 and 5 of the E-Que rear card are connected using standard straight-through CAT-5 cables rather than crossover CAT-5 cables.

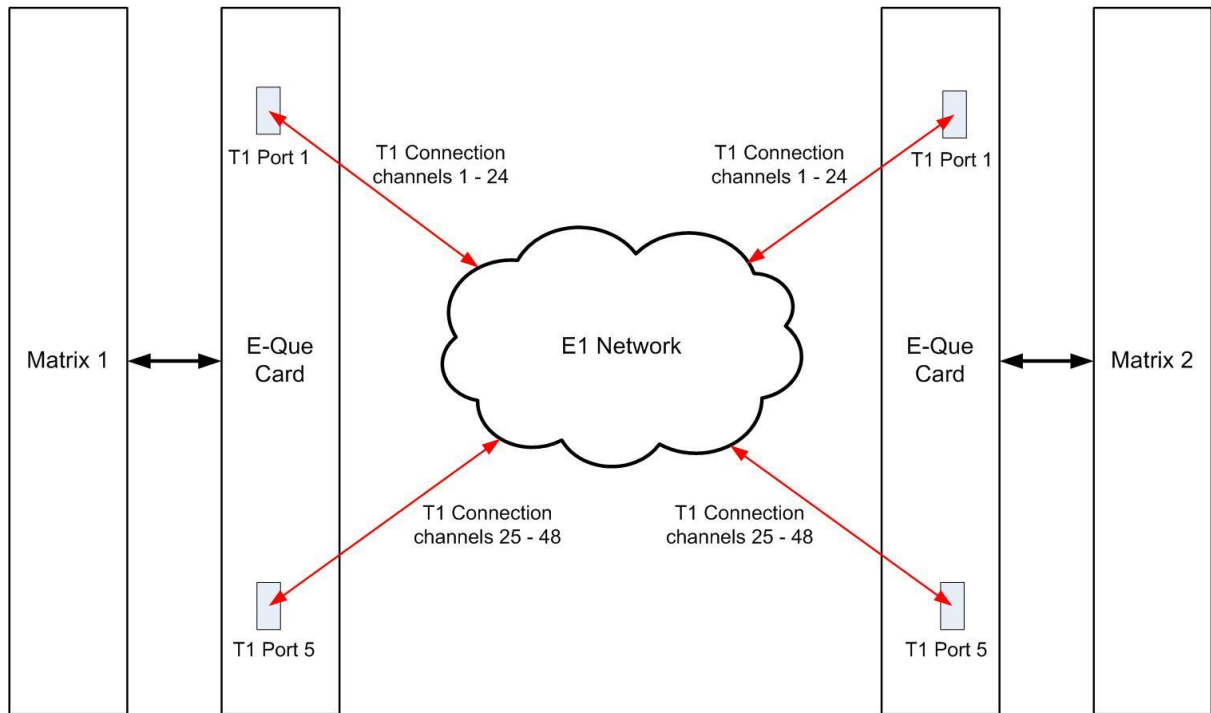

Figure 8-10: T1 Trunking using an E1 Network

## 8.9 Trunking failover

Where the E1/T1 trunking has been configured with redundant trunks, audio will be switched from the primary trunk to the backup trunk when a failure is detected.

When failover occurs from primary to backup there will be a three second audio break on any route running over the trunk.

If the trunk routing is later switched back from the backup trunk to the primary trunk there will be no loss of audio.

## 9 ***IVC-32 card for IP-based connections***

---

The **IVC-32 (*Instant Voice Communication*) interface card** provides the Eclipse HX-Omega with connectivity over IP to **V-Series IP panels and Concert servers**.

Each IVC-32 interface card comprises:

- A front card with a reset button and various status indicators (including status LEDs for power, port activity and LAN status).  
**Note:** The port activity LEDs are not active on the IVC-32 front card as the E1/T1 ports are not used.
- A rear card with eleven RJ-45 ports giving eight E1/T1 ports (not used), DECT sync in and out (not used) and a LAN port used for the IP connection.

**Note:** An Ethernet cable **must** be connected to the IVC-32 interface LAN port for the card to function correctly.

**Tip:** For an overview of the Eclipse HX-Omega matrix, see **3 Overview** in this guide.

## 9.1 IVC-32 front panel lights and controls

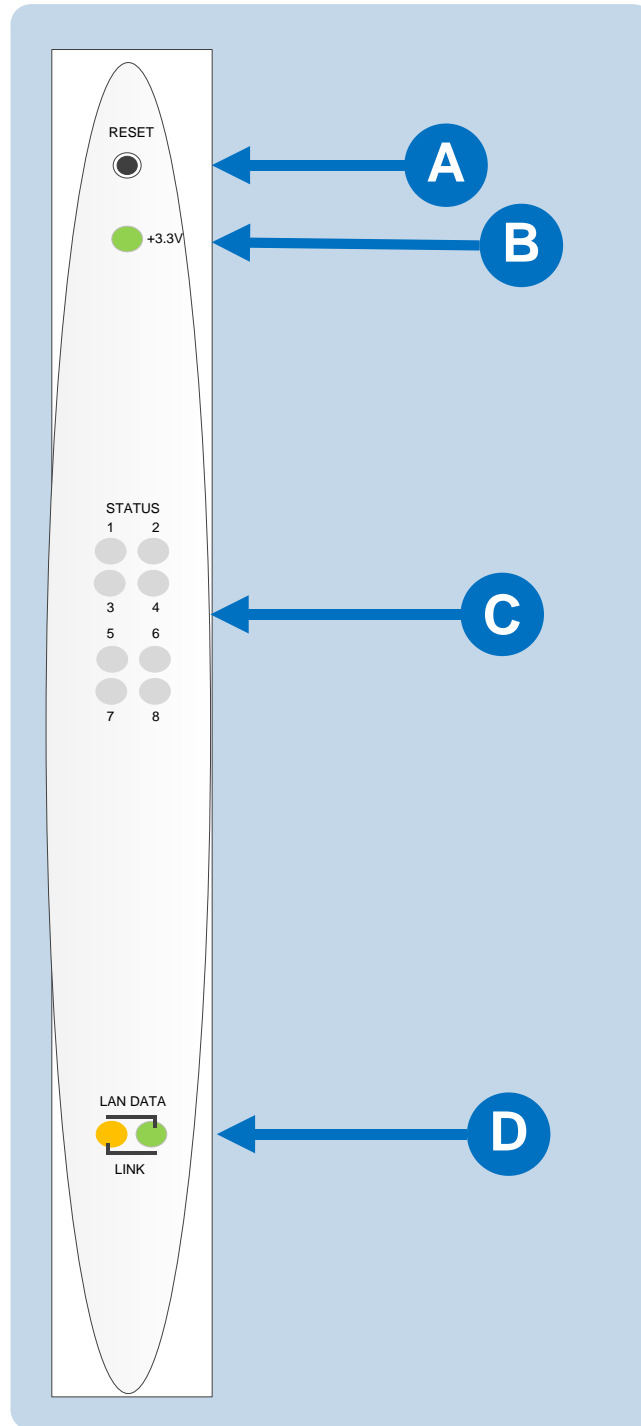

Figure 9-1: IVC-32 front panel lights and controls





Key to Figure 40: IVC-32 front panel lights and controls	
Feature	Description
	<p><b>RESET button</b></p> <p>Pressing the reset button causes the card and all links to momentarily stop their current activity and to restart.</p> <p>During the reset, configuration information downloads to the card from the CPU card. If the entire system is operating except for one IVC-32 interface press the reset button for that card only.</p> <p><b>Tip:</b> <i>The reset button is slightly recessed from the front panel to prevent it from being accidentally pressed. A tool such as a bent paper clip is required to press this button.</i></p>
	<p><b>Power supply light</b></p> <p><b>+3.3-Volt Power Supply Light</b></p> <p>The matrix's +3.3-volt power supply provides electric current to this green light. When lit, the light indicates that the +3.3-volt supply is present and supplying power to the card.</p>
	<p><b>Status lights (normally inactive)</b></p> <p>When lit, a <b>yellow status light</b> indicates IP communication between the card and E1/T1 connected devices. The first status light represents the first four connected panels, the second the next four panels, and so on.</p> <p>Under normal circumstances, however, E1/T1 devices are <b>not connected</b> to an IVC-32 interface card, which means that these lights are <b>normally inactive</b>.</p>
	<p><b>LAN DATA</b></p> <p>The <b>green LAN DATA</b> light illuminates to indicate there is data passing through the Ethernet port.</p> <p><b>LAN LINK</b></p> <p>The <b>amber LAN LINK</b> light illuminates to indicate a connection to the LAN port.</p>

Table 9-1: Key to IVC-32 front panel lights and controls

## 9.2 IVC-32 rear panel connectors

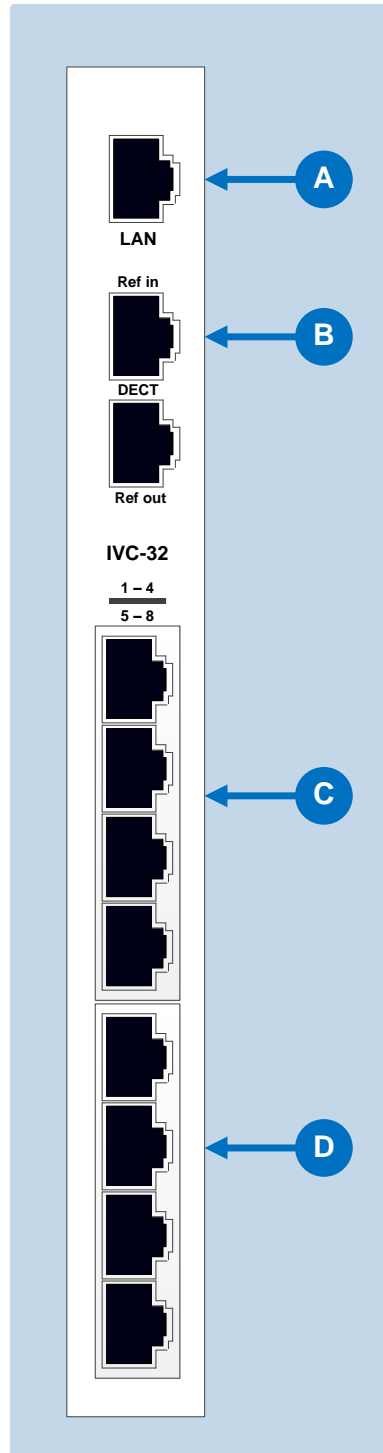

Figure 9-2: IVC-32 rear panel connectors

Key to Figure 41: IVC-32 rear panel connectors	
Feature	Description
<b>A</b>	<b>LAN port (RJ-45)</b>
<b>B</b>	DECT sync ports: <b>DECT Ref in (Not used)</b> <b>DECT Ref out (Not used)</b>
<b>C</b>	<b>E1 / T1 Port 1 (Not used)</b> <b>E1 / T1 Port 2 (Not used)</b> <b>E1 / T1 Port 3 (Not used)</b> <b>E1 / T1 Port 4 (Not used)</b>
<b>D</b>	<b>E1 / T1 Port 5 (Not used)</b> <b>E1 / T1 Port 6 (Not used)</b> <b>E1 / T1 Port 7 (Not used)</b> <b>E1 / T1 Port 8 (Not used)</b>

Table 9-2: Key to IVC-32 rear panel connectors

**Note:** The E1/T1 and DECT ports are **not used** on the IVC-32 interface and **should not be connected**.

## 9.3 IVC-32 interface card applications

The IVC-32 interface may be used to connect:

- V-Series IP panels to an Eclipse HX matrix.
- Different Eclipse HX Matrices to each other using IP linking and trunking.
- Provide a link to a Concert Instant Voice Router (IV-R) server.

### 9.3.1 V-Series IP Panels

V-Series panels with V5.1 or later software may be enabled to communicate with an Eclipse HX-Omega or Eclipse HX-Median matrix over an IP network via the IVC-32 interface.

The advantage of using IP communication is that it enables remote panels to communicate over an existing local (LAN) or wide area (WAN) network rather than requiring a dedicated link.

### 9.3.2 IP linking and trunking

The Eclipse IVC-32 cards allow directs and trunks over IP network infrastructure. All IP trunks and directs can be compared directly to 4-wire trunks and directs. They consist of:

A single duplex audio channel

A known start point and end point

Links have to be made over IP before the trunk/direct can be used.

### 9.3.3 Concert users

The IVC-32 interface card will allow Concert users to establish audio links with users on the Eclipse matrix via the Concert IV-R server.

This server will provide a link over IP between Concert users and the Eclipse HX matrix. Concert users cannot connect directly to the IVC-32 interface.

Concert users communicate with Eclipse HX users via a soft panel rather than the main concert client interface.

This soft panel is configured using the EHX configuration software and the configuration information is uploaded to the Concert user's soft panel on connection to the matrix.

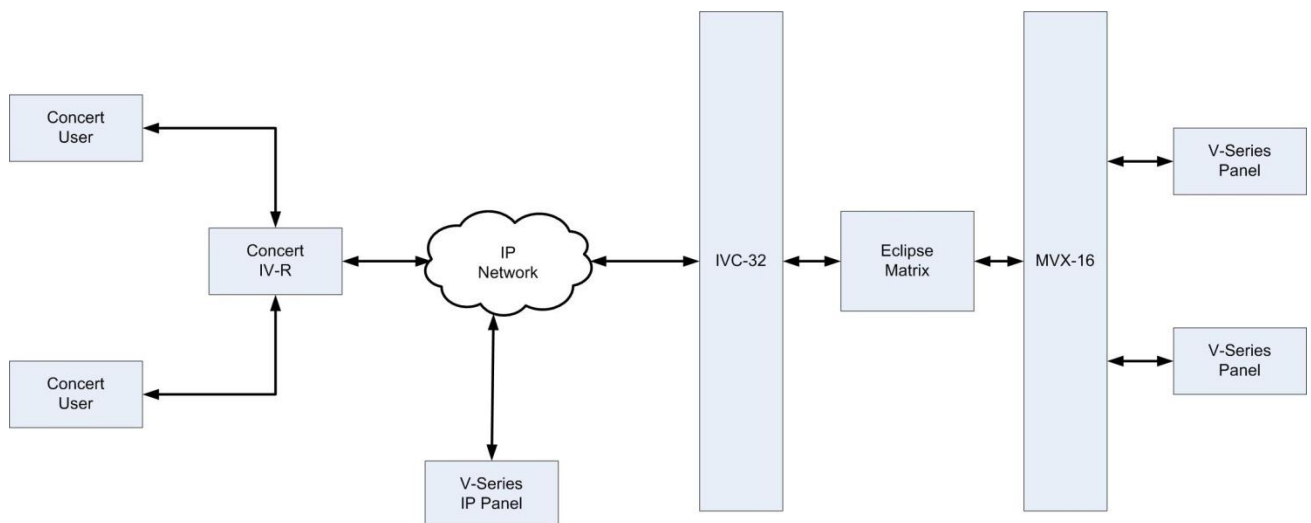

Figure 9-3: IP communication using an IVC-32 interface

## 10 LMC-64 metering card

---

The **Level Meter Card (LMC-64) interface** enables the Eclipse HX-Omega to provide audio level metering for Production Maestro Pro over a network. Each LMC-64 interface card can meter up to **64 partylines** and **four-wire ports**. The LMC-64 card set comprises:

- A front card with a reset button and various status indicators (including status LEDs for power, port activity and LAN status).  
**Note:** The port activity LEDs are **inactive** on the LMC-64 front card as the E1/T1 ports are **not** used.
- A rear card with eleven RJ45 ports giving eight E1/T1 ports (not used), DECT sync in and out (not used) and a LAN port used for the IP connection.

Up to six LMC-64 interfaces can be fitted on an Eclipse HX-Omega matrix if the matrix has a Power-One PSU. Otherwise up to four can be fitted.

**Note:** An Ethernet cable must be connected to the LMC-64 interface LAN port for the card to function correctly.

**Note:** For an overview of the Eclipse HX-Omega matrix, see **3 Overview** in this guide.

## 10.1 LMC-64 front panel lights and controls

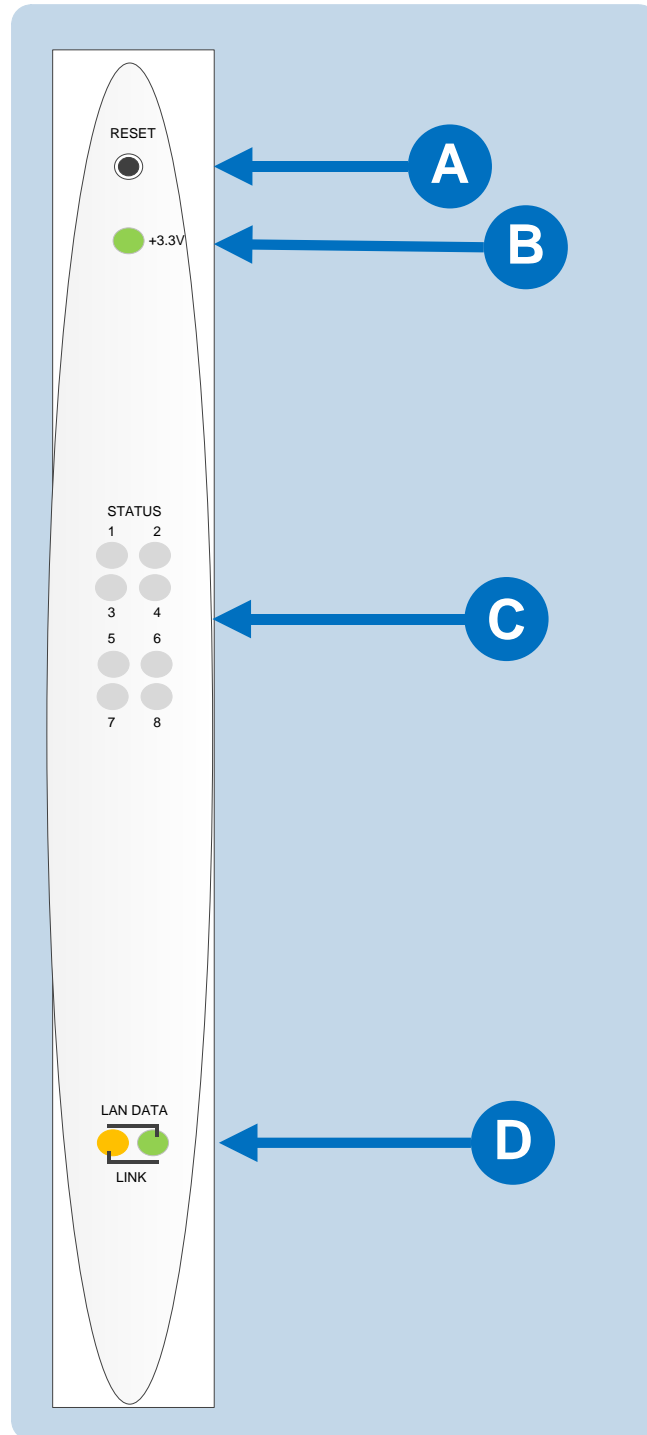

Figure 10-1: LMC-64 front panel lights and controls

Key to Figure 43: IVC-32 front panel lights and controls	
Feature	Description
<b>A</b>	<p><b>RESET button</b></p> <p>Pressing the reset button causes the card and all links to momentarily stop their current activity and to restart.</p> <p>During the reset, configuration information downloads to the card from the CPU card. If the entire system is operating except for one LMC-64 interface press the reset button for that card only.</p> <p><b>Tip:</b> <i>The reset button is slightly recessed from the front panel to prevent it from being accidentally pressed. A tool such as a bent paper clip is required to press this button.</i></p>
<b>B</b>	<p><b>Power supply light</b></p> <p><b>+3.3-Volt Power Supply Light</b></p> <p>The matrix's +3.3-volt power supply provides electric current to this green light. When lit, the light indicates that the +3.3-volt supply is present and supplying power to the card.</p>
<b>C</b>	<p><b>Status lights (normally inactive)</b></p> <p>When lit, a <b>yellow status light</b> indicates successful communication between an E1/T1 port on the LMC-64 interface and a connected E1/T1 device such as an active antenna or splitter.</p> <p>However, under normal circumstances, E1/T1 devices are <b>not connected</b> to an LMC-64 interface, which means that these lights are <b>normally inactive</b>.</p>
<b>D</b>	<p><b>LAN DATA</b></p> <p>The <b>green LAN DATA</b> light illuminates to indicate there is data passing through the Ethernet port.</p> <p><b>LAN LINK</b></p> <p>The <b>amber LAN LINK</b> light illuminates to indicate a connection to the LAN port.</p>

Table 10-1: Key to LMC-64 front panel lights and controls

## 10.2 LMC-64 rear panel connectors

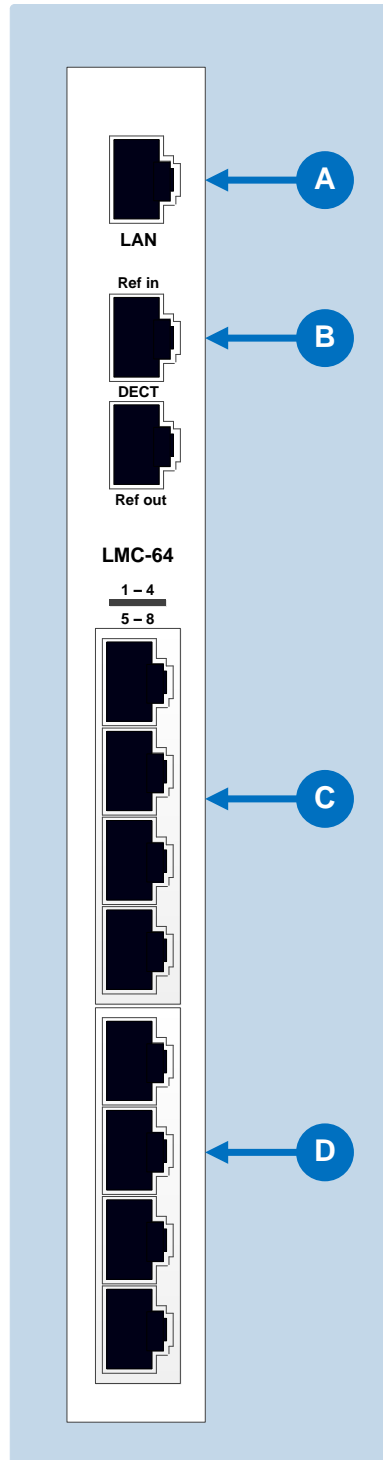

Figure 10-2: LMC-64 rear panel connectors

Key to Figure 44: LMC-64 rear panel connectors	
Feature	Description
<b>A</b>	<b>LAN port (RJ-45)</b>
<b>B</b>	DECT sync ports: <b>DECT Ref in (Not used)</b> <b>DECT Ref out (Not used)</b>
<b>C</b>	<b>E1 / T1 Port 1 (Not used)</b> <b>E1 / T1 Port 2 (Not used)</b> <b>E1 / T1 Port 3 (Not used)</b> <b>E1 / T1 Port 4 (Not used)</b>
<b>D</b>	<b>E1 / T1 Port 5 (Not used)</b> <b>E1 / T1 Port 6 (Not used)</b> <b>E1 / T1 Port 7 (Not used)</b> <b>E1 / T1 Port 8 (Not used)</b>

Table 10-2: Key to LMC-64 rear panel connectors

**Note:** The E1/T1 and DECT ports are not used on the IVC-32 interface card and should not be connected.

### 10.3 LMC-64 interface card applications

The LMC-64 interface broadcasts audio level data to Production Maestro Pro clients over an IP network. This enables multiple Production Maestro Pro clients across a network to display any audio level that is being metered.

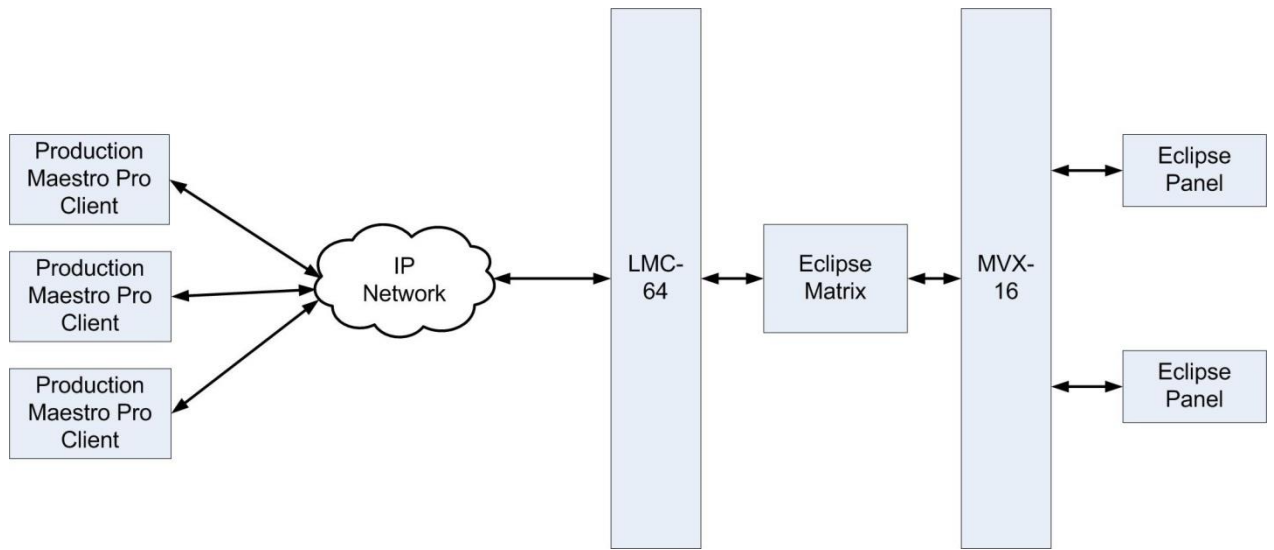

Figure 10-3: LMC-64 applications

## 11 *E-Dante64-HX card*

---

This section contains information about audio networking using an E-DANTE64-HX interface card. This is a Clear-Com matrix interface card that is enabled to work with Dante network protocols and software so that you can transport many channels of high quality audio via a Clear-Com matrix to multiple Dante enabled devices using standard Ethernet network structure (up to 64 channels per E-DANTE64 card).

This section will describe and illustrate the card with its connections, controls and status LEDs. It will also cover how to install the card. There are also sections on how to upgrade the devices and a troubleshooting or FAQ section.

This guide uses some screenshots and instructions from Audinate documentation for your convenience. Be aware that while these are correct at the time of publishing, Audinate may change its documentation and user interfaces. If in doubt, refer to the Audinate documentation.

For information about configuring the card, see the EHX Configuration User Guide and Audinate documentation.

For recommendations for network devices and infrastructure, refer to [www.audinate.com](http://www.audinate.com), and for specific AES-67 support refer to the Clear-Com Solution Finder, [www.clearcom.com/support/clear-com-solution-finder](http://www.clearcom.com/support/clear-com-solution-finder).

## 11.1 Example applications

### 11.1.1 Interruptible Foldback (IFB) over Dante

Example application, broadcasting.  
Interruptible Foldback (IFB) over Dante.

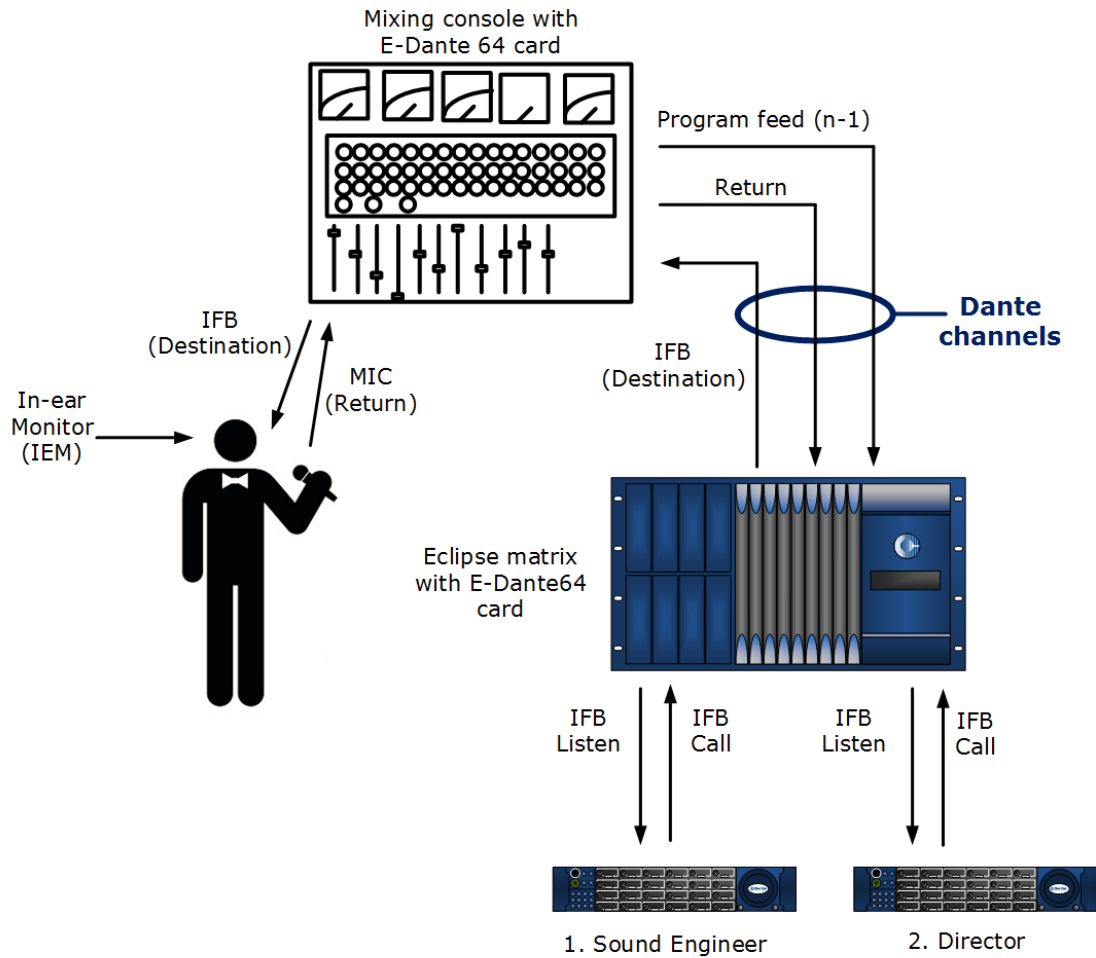

EHX IFB configuration

#	Label	Description	Attenuation	Source(s)	Destination(s)	Return(s)
1	IFB001	IFB to talent	-18 dB	N-1	IEM	Mic

Figure 11-1 IFB over Dante

### 11.1.2 Live performance interface with digital intercom

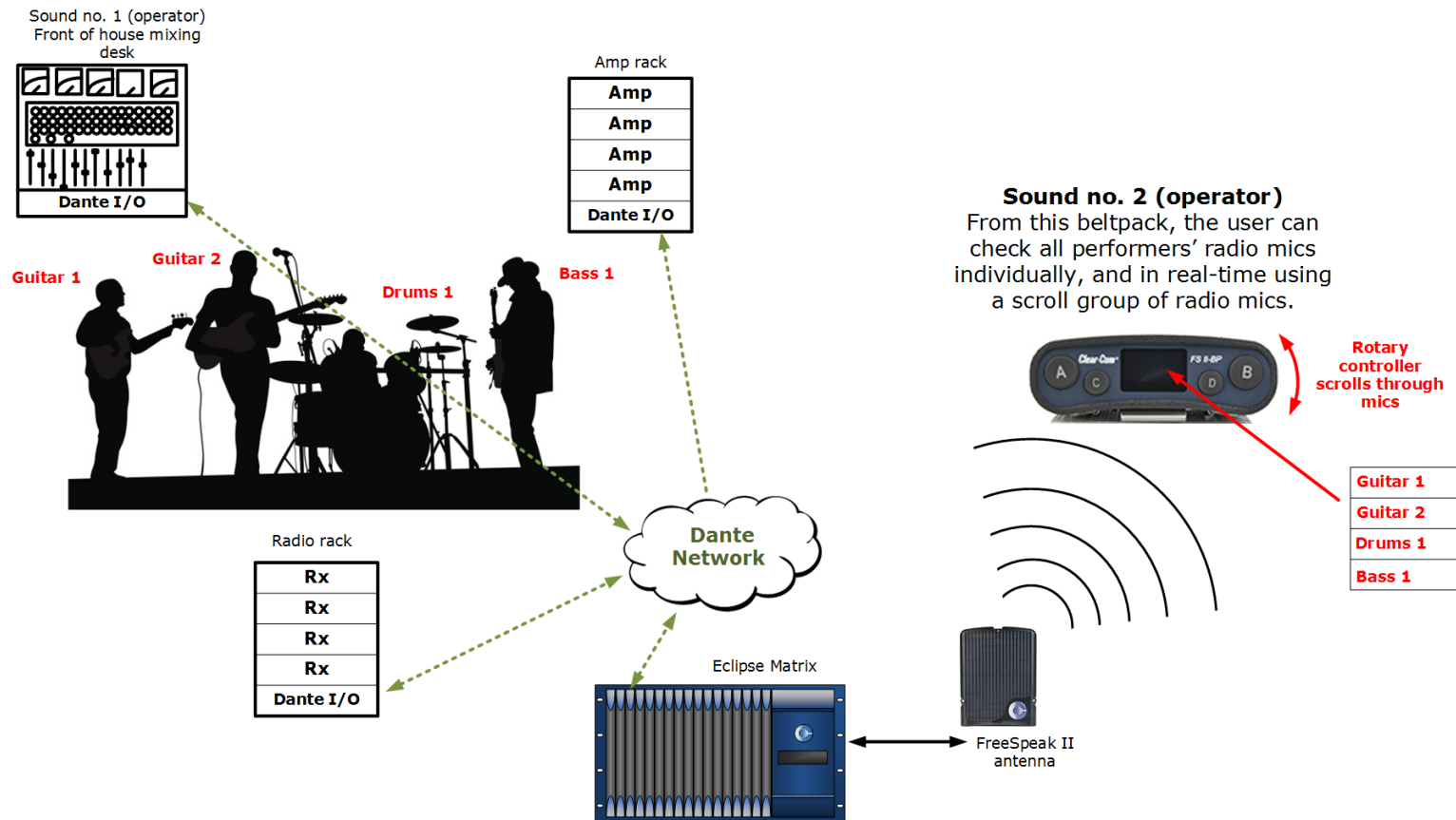

Figure 11-2 Live performance interface with Clear-Com digital intercom

## 11.2 Using the E-DANTE64-HX card

To route audio using a Clear-Com Dante card you must already have the Audinate Dante Controller installed on your PC (or similar device that can set up Dante routes). The Dante Controller can be downloaded from the Audinate website.

### 11.2.1 Install the Dante card on your matrix and connect Primary and Secondary networks

Always install the rear card in an interface card set before the front card. When installing the rear card, the matrix should be powered off. However, Clear-Com front interface cards are hot pluggable, there is no need to power off the matrix when removing or replacing the front section of the card.

See *Installing Interface Cards* in the Clear-Com matrix user guides for detailed instructions (available from the Clear-Com website).

- 1) Install the E-DANTE64-HX card.
- 2) Connect the primary network to the primary network switch on the E-DANTE64-HX card using RJ45 Ethernet or Fiber cable.
- 3) Connect the secondary network to the secondary network switch on the E-DANTE card (if you are using a secondary network).

**Note:** The card can be used with an RJ45 Ethernet or a Fiber Ethernet connection for either network. Valid combinations are:

Primary	Secondary
RJ45	RJ45
RJ45	Fiber
Fiber	Fiber
Fiber	RJ45

If you try and mix RJ45 and Fiber on one network the audio will stop working.

**Note:** Network configuration including IP addressing is managed by the Dante software rather than EHX. See **11.5 Network configuration** for more details.

## 11.3 E-DANTE64-HX front panel lights and controls

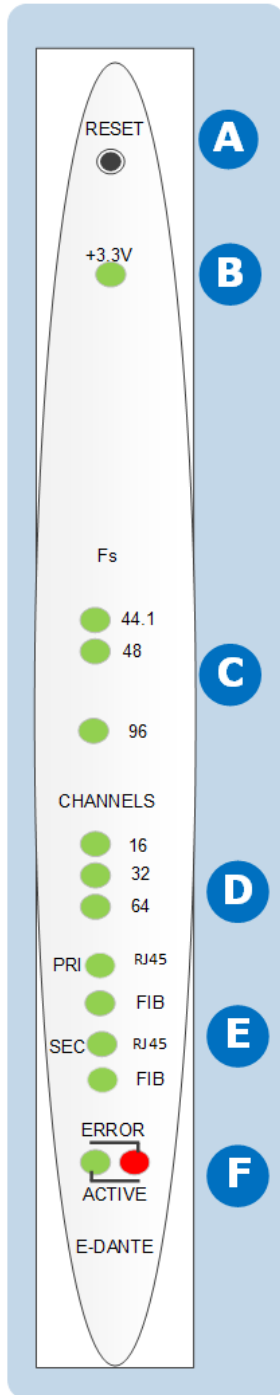

Feature	Description
<b>A</b>	<p><b>Reset button</b></p> <p>Pressing the <b>Reset</b> button causes the card and all links to momentarily stop their current activity and to restart. The <b>flashing green Active</b> light goes off when the reset starts and comes back on when the reset is complete.</p> <p>During the reset, configuration information downloads to the card from the matrix CPU card.</p> <p>Note: <i>The reset button is slightly recessed. A tool such as a bent paper clip is needed to press this button.</i></p>
<b>B</b>	<p><b>+3.3 Volt Power Supply LED</b></p> <p>Indicates that power is being supplied to the card.</p>
<b>C</b>	<p><b>Sample rate (Sampling frequency)</b></p> <p>A <b>green</b> LED indicates the current sampling rate of the E-DANTE64 device. The sample rate is set in the Dante Controller (<b>Routing Screen&gt;double click Device&gt;Device Config&gt;New Sample Rate</b>). Dante enabled devices on the same network <b>must</b> have the same sample rate, or they will not connect.</p> <p>Note: <i>A sample rate of <b>96KHz</b> will limit the number of channels available on the E-Dante64-HX card to <b>32</b>.</i></p>
<b>D</b>	<p><b>Channels</b></p> <p>This LED indicates the number of channels available on the card. This indicator is determined by sample rate. If the selected sample rate is 96KHz, 32 channels are available, not 64.</p>
<b>E</b>	<p><b>Primary and Secondary network connection LEDs</b></p> <p>When lit, these LEDs show that the card is connected to a network switch or switches, either RJ45 or Fiber. The color of the LED indicates speed of connection. This network connection LED will flicker and flash to indicate network traffic.</p> <p>If RJ45: An <b>amber</b> LED indicates 100Mbps connection. An LED lit <b>green</b> indicates 1Gbps connection. Clear-Com does not recommend using less than 1Gbps in most circumstances, as</p>

	100Mbps will only support a small number of Dante channels. A Fiber connection is always 1Gbps and is always green.
<b>F</b>	<p><b>Active LED</b></p> <p>The <b>Active (matrix data) LED flashes green</b> (1:1 at 1Hz) to indicate successful communication between the E-DANTE64-HX interface and the CPU card. This LED will flash twice as fast while a card is being upgraded and firmware is being installed (EHX firmware only, the light will stay as normal while Dante firmware is being installed).</p> <p><b>Error LED</b></p> <p>Possible error conditions:</p> <ol style="list-style-type: none"><li>1. Expected networks not connected on back of card. See EHX Configuration User Guide for redundancy options for this card.</li><li>2. Card configuration does not match card or cards installed. The name on a card in a card slot does not match the name the EHX software has for that slot.</li></ol> <p><i>During boot up, the <b>Active</b> and <b>Error LEDs</b> flash rapidly until the boot sequence is completed.</i></p>

## 11.4 E-DANTE64-HX rear panel lights and controls

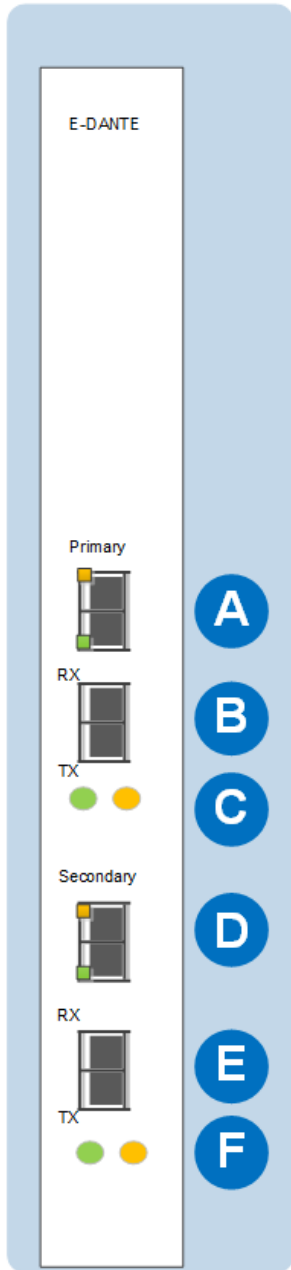

**Note:**  
Green LED = 1 Gbps connection  
Amber LED = 100 Mbps connection

Feature	Description
<b>A</b>	<b>Primary network connector RJ45</b> See <b>Note</b> below.
<b>B</b>	<b>Primary network connector Fiber</b> You will install a Clear-Com SFP/Mini-GBIC in this slot. See Specifications section for details.
<b>C</b>	<b>Primary Fiber connection LEDs</b> The <b>green</b> LED indicates that the network (Primary or Secondary) is successfully connected. <b>Amber</b> LED is not in use.

Feature	Description
<b>D</b>	<b>Secondary network connector RJ45</b> See <b>Note</b> below.
<b>E</b>	<b>Secondary network connector Fiber</b> In this slot you will install a Clear-Com SFP/Mini-GBIC. See Specifications section for details.
<b>F</b>	<b>Secondary Fiber connection LEDs</b> The <b>green</b> LED indicates that the network (Primary or Secondary) is successfully connected. <b>Amber</b> LED is not in use.

**Note:** If using RJ45 cable, the small LEDs on the connector indicate connection speed. **Green** indicates 1Gbps connection. **Amber** indicates 100Mbps connection. Clear-Com does not recommend using less than 1Gbps in most circumstances, as 100Mbps will only support a small number of Dante channels. The Fiber connection LED always lights **green**.

**Note:** If you try and use both RJ45 and Fiber connectors at the same time on one network the audio will stop working.

## 11.5 Network configuration

IP addressing is handled by the Dante software:

### Automatic network configuration

A Dante-enabled device connected to a network will automatically setup its own network configuration, including its IP address.

If the network has a DHCP server, which may be the case for installed networks, it will receive its IP configuration using the standard DHCP protocol.

On a network without a DHCP server, which may be the case for temporary or smaller networks, the Dante-enabled device will automatically assign itself an address using link local protocols, in the same way PCs and printers often do.

See *Audinate Dante Controller User Guide*, 2016 Audinate Pty Ltd.

**Note:** DHCP is the preferred method of IP allocation when using Dante.

The E-Dante64 card IP address is set by the Dante controller. This IP address is different from the main Eclipse Matrix (LAN) IP address.

Clear-Com recommends that the Eclipse Matrix (LAN) IP address uses a fixed/static IP address.

## 11.6 Installing a replacement or backup card

When you remove an E-DANTE64-HX interface card from the Clear-Com matrix rack, any channel subscriptions (connections) that have been made in the Dante Controller are removed as they are stored on the card. You need to re-apply these subscriptions in the Dante Controller using the **Load Preset** function for the backup card.

- 1) Remove the front E-DANTE64 card from the matrix rack by gently opening the side ejector tabs and pulling the card out of its slot.
- 2) Carefully insert the new card and push it home, closing the side ejector tabs to secure it in the matrix.

**The new card may have pre-existing configuration on it. Use the Dante controller to make sure that the configuration is as you want it.**

- 3) Open the Dante Controller and apply the required preset configuration (**File>Load Preset**).

At this point, you can either use the card immediately, or you can check that audio is flowing as required and keep the replacement card aside for use when needed.

**Note:** Changing the E-DANTE64 rear card requires a power down of the matrix. The front card can be replaced without power-down (hot plugged).

## 11.7 Upgrading your E-DANTE64-HX card

Upgrades for your E-DANTE64-HX card are available for both EHX and Dante firmware and are available from your Clear-Com representative.

The upgrade process for each of the two modules on the card (EHX and Dante) is different. The two processes are outlined below.

**Note:** When upgrading your E-Dante64 card, only use the Clear-Com supplied upgrade files for both

(A: EHX) ClearCom - App, Boot, DSP, FPGA: xxxxxx.FWC files

(B: Dante) ClearCom [Brooklyn]: xxxxxx.dnt file.

**To check if your firmware is up to date, open the Firmware Report in EHX:**

- 1) In the EHX software, navigate to the **Layout** tab.
- 2) Right click on the required matrix and select **Firmware/Firmware Report**.

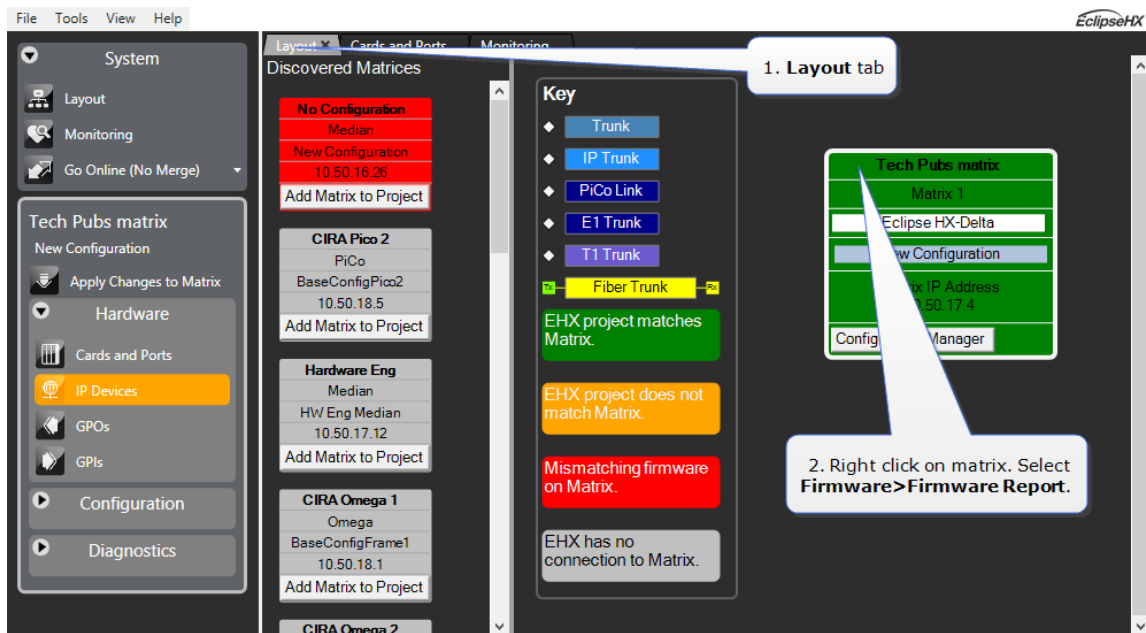

### 11.7.1 Upgrade EHX E-DANTE64 firmware

- 1) In the EHX software, navigate to the **Layout** tab.
- 2) Right click on the matrix to be upgraded and select **Firmware > Update Firmware > Card**.
- 3) Navigate to where the E-Dante64 upgrade file is stored and click to upload.

There are 4 possible upgrade file types.

Upgrade file type	Approximate upgrade time/notes
App.FWC	2 min. This is the most common file to upgrade and is usually labeled 'Clearcom'.
Boot.FWC	1 min.
DSP.FWC	3 min. Reset card on front panel after upgrade.
FPGA.FWC	16 mins.

While the E-DANTE64 card is being upgraded with EHX firmware, the active light (green) on the front of the device will flash at double its usual speed and the error light (red) will show. The card is ready for use when the error light is off and the status light has returned to a steady 1Hz pulse.

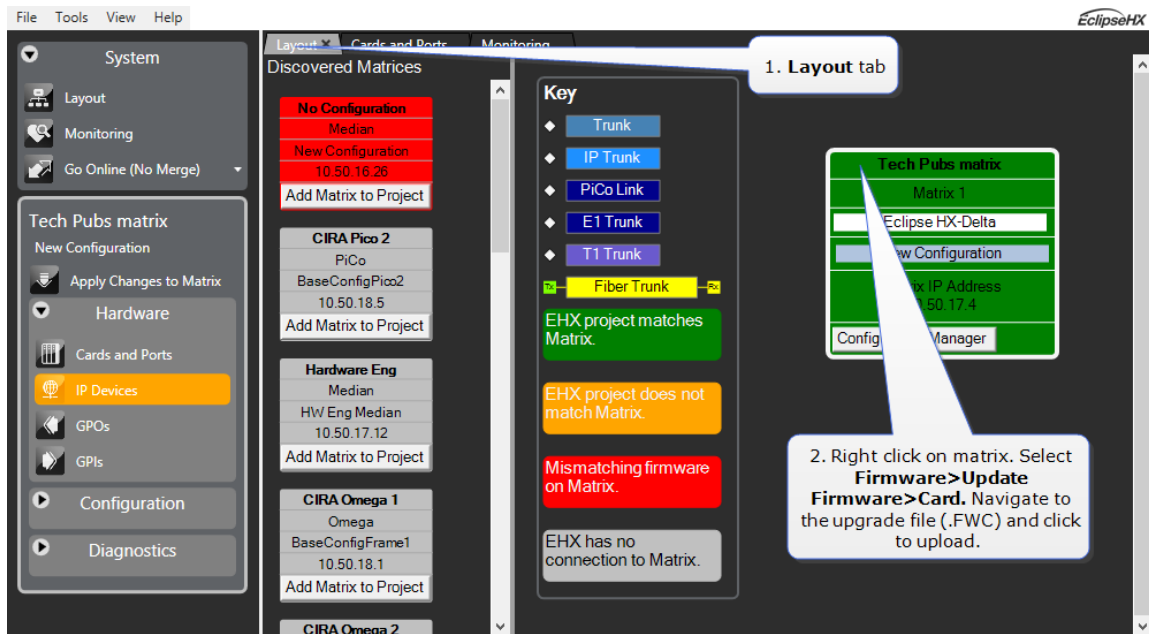

**Note:** The EHX component of the E-Dante64 card is both **centrally** upgradable (you can upgrade the E-Dante64 through the matrix, using EHX) and locally upgradeable, using Xilinx software, a PC and a Xilinx download cable. The process is the same as for a Clear-Com MADI card.

For more information, see the *Eclipse HX Upgrade Guide* and refer to the section on MADI.

### 11.7.2 Upgrade Dante firmware

Before updating the Dante component of your E-DANTE64 card, you must first download the Dante Firmware Update Manager from the Audinate website.

Open the Dante Firmware Update Manager and follow the instructions on the screen.

The Dante firmware upgrade file (usually labeled 'Brooklyn') has a **.dnt** extension.

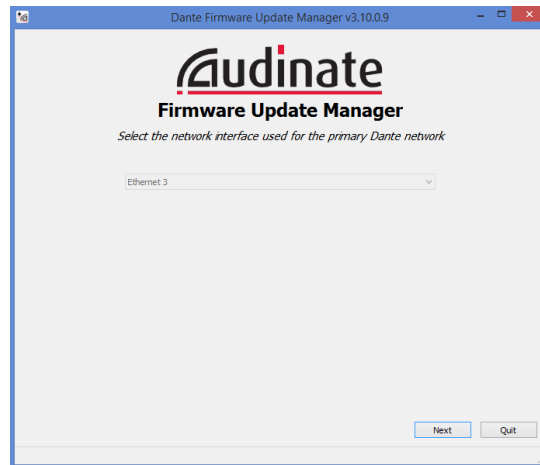

**Figure 11-3 Audinate Firmware Update Manager**

**Note:** Disable any firewalls before upgrading the E-Dante combined Brooklyn file via Dante Firmware Update Manager.

**Note:** When upgrading firmware for the Dante component, the status light on the front of the E-Dante64 card will not change.

## 11.8 Troubleshooting: Sample rate

Dante devices **must** be set to the same sample rate for audio to pass between them. Set sample rate for all devices in the Dante Controller. Right click on device icon in the **Routing** page to open **Device View>Device Config**.

## 11.9 Troubleshooting: I need to find the E-Dante64 card's IP address

In most cases the E-Dante64 card will be discovered by the Dante Controller and be available for configuration in the controller's **Routing** page.

**Cards that have been 'misplaced' and are not visible in the routing screen are those that have been configured with a static IP address that falls outside the subnet which the PC hosting the controller is on.**

To remedy this you will need to:

- Find the card IP address in the Dante controller
- Make sure both devices, the PC hosting the controller and the E-Dante64 card are on the same subnet
- Access the card and reallocate IP as required.

## 11.9.1 Find the device IP address

If the E-Dante card is on a different subnet to the PC, the card will not be visible in the routing screen, but will be available under **Device Info** where it will show with a red highlight.

Click to see device IP address

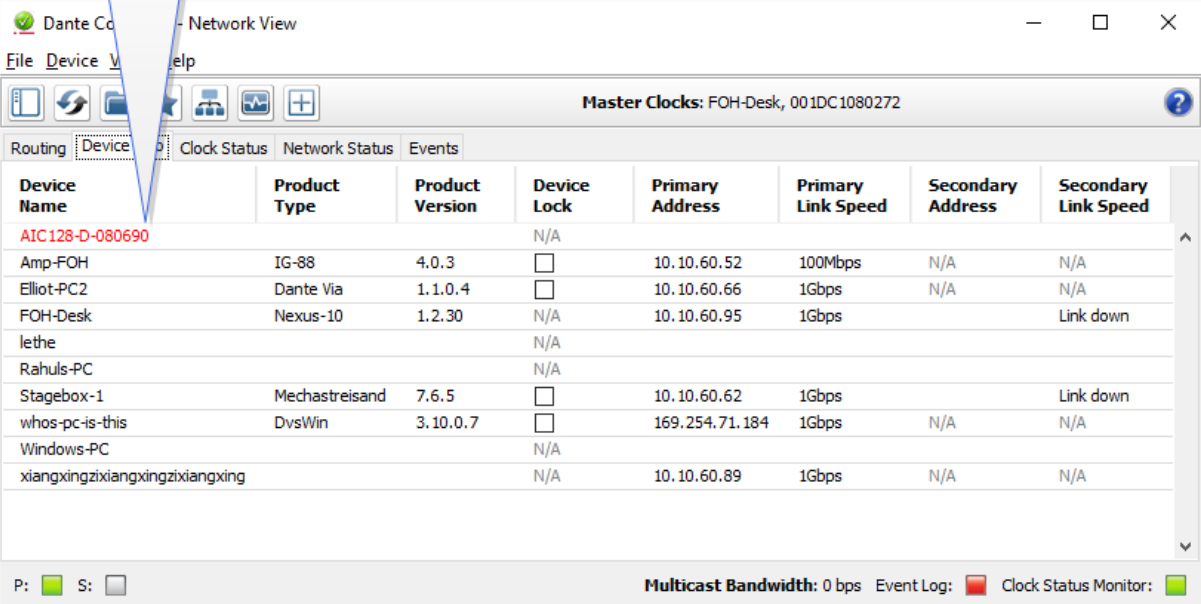

The screenshot shows the Dante Controller Network View interface. A callout box points to the 'AIC128-D-080690' device name in the table, which is highlighted in red. The table lists various devices with their IP addresses and link speeds.

Device Name	Product Type	Product Version	Device Lock	Primary Address	Primary Link Speed	Secondary Address	Secondary Link Speed
AIC128-D-080690			N/A				
Amp-FOH	IG-88	4.0.3	<input type="checkbox"/>	10.10.60.52	100Mbps	N/A	N/A
Elliot-PC2	Dante Via	1.1.0.4	<input type="checkbox"/>	10.10.60.66	1Gbps	N/A	N/A
FOH-Desk	Nexus-10	1.2.30	N/A	10.10.60.95	1Gbps		Link down
lethe			N/A				
Rahuls-PC			N/A				
Stagebox-1	Mechastreisand	7.6.5	<input type="checkbox"/>	10.10.60.62	1Gbps		Link down
whos-pc-is-this	DvsWin	3.10.0.7	<input type="checkbox"/>	169.254.71.184	1Gbps	N/A	N/A
Windows-PC			N/A				
xiangxingzixiangxingzixiangxing			N/A	10.10.60.89	1Gbps	N/A	N/A

P:  S:  Multicast Bandwidth: 0 bps Event Log:  Clock Status Monitor:

Figure 11-4 Find IP address 1

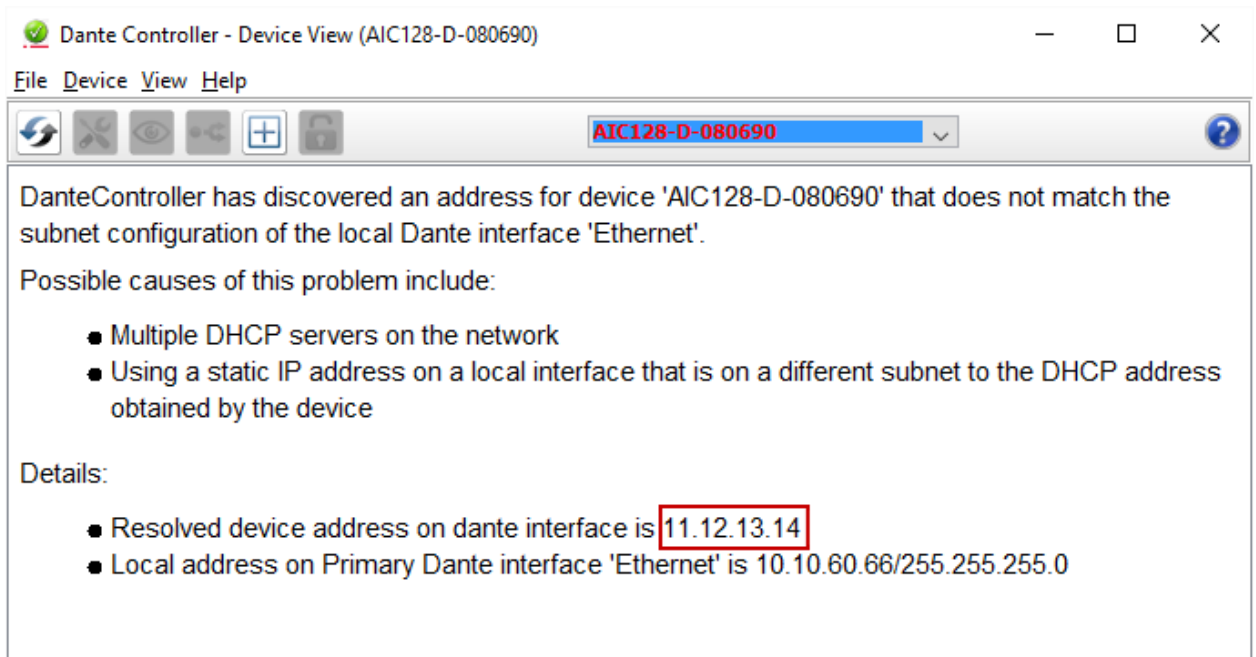

Figure 11-5 Find IP address 2

### 11.9.2 Make sure both devices are on the same subnet

In order to be able to configure the E-Dante card as usual, you must make sure that the PC hosting the controller is in the same IP range (subnet) as the card.

Once you have reset the IP address of the PC accordingly, the 'misplaced' E-Dante card will be visible in the routing screen for configuration. From this point you can manually reset the IP address of the E-Dante64 card as required.

### 11.9.3 Reset the IP address of the Dante Controller.

Set the IP address in the **Network Config** screen of the Dante Controller.

Note: Dante devices use DHCP by default, and in most cases this is the recommended IP selection method.

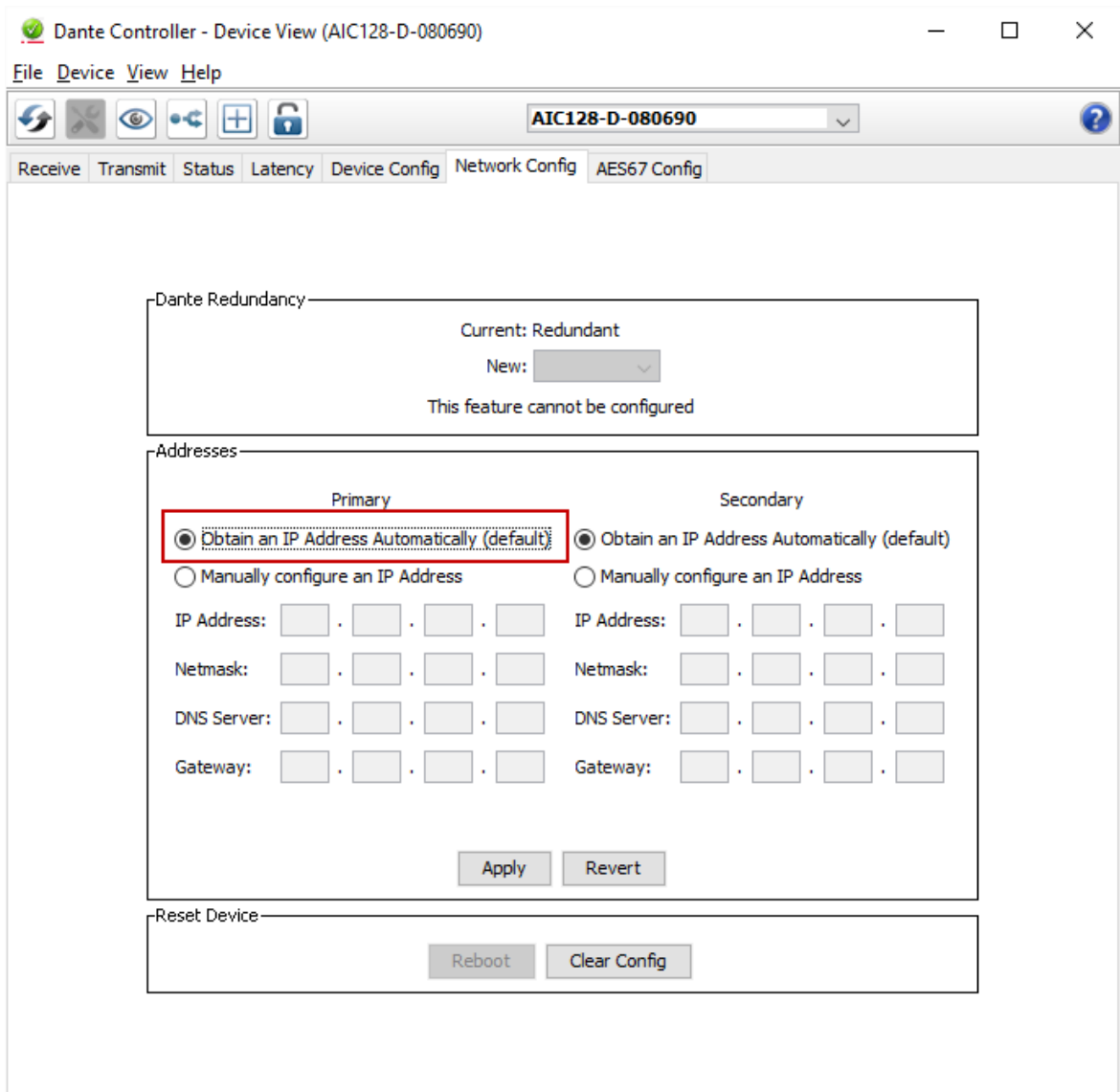

Figure 11-6 Reset IP address

### 11.9.4 Link-local

The link-local IP range is a special case (169.254.1.0 – 169.254.254.255).

The Dante Controller will NOT see an E-Dante64 card with a link-local IP address if the PC hosting it is not set to the link-local IP range also. In this case, you need to change the PC's IP address to a value in the link-local range before you can access and configure the card.

For more information see the Audinate website:  
<https://www.audinate.com/faq/how-can-i-locate-dante-device-static-ip-address-unknown-subnet> (last accessed 16th February 2017).

### 11.9.5 AES67 Guidelines

When connecting devices to route AES67 audio streams with your E-DANTE 64 card, the following general principles should be noted:

- AES67 uses IEEE1588-2008 Precision Time Protocol (PTP) to ensure synchronization between devices. All networked devices, including your network switch must support this standard.
- You need to disable any Energy Efficient Ethernet (EEE) switches, as these will disrupt the synchronization of audio streams.
- All networked devices need to support multicast routing. The Dante system defaults to multicast when routing AES67 streams.
- Multicast routing uses the Class D range of IP addresses (224.x.x.x – 239.x.x.x). For AES67 streams, chose an IP range that does not conflict with other network traffic. Consult your network administrator if necessary.
- It is recommended that Internet Group Management Protocol (IGMP) snooping is enabled on your network switch. This will avoid the possibility of flooding your network.

- Dante uses Session Announcement Protocol (SAP) to discover devices on a network. If any of your devices do not support SAP, the Dante Controller will not be able to see them. In this case, you need to use a SAP conversion tool, such as the free Ravenna-2-SAP converter available from the Ravenna website, <https://www.ravenna-network.com>

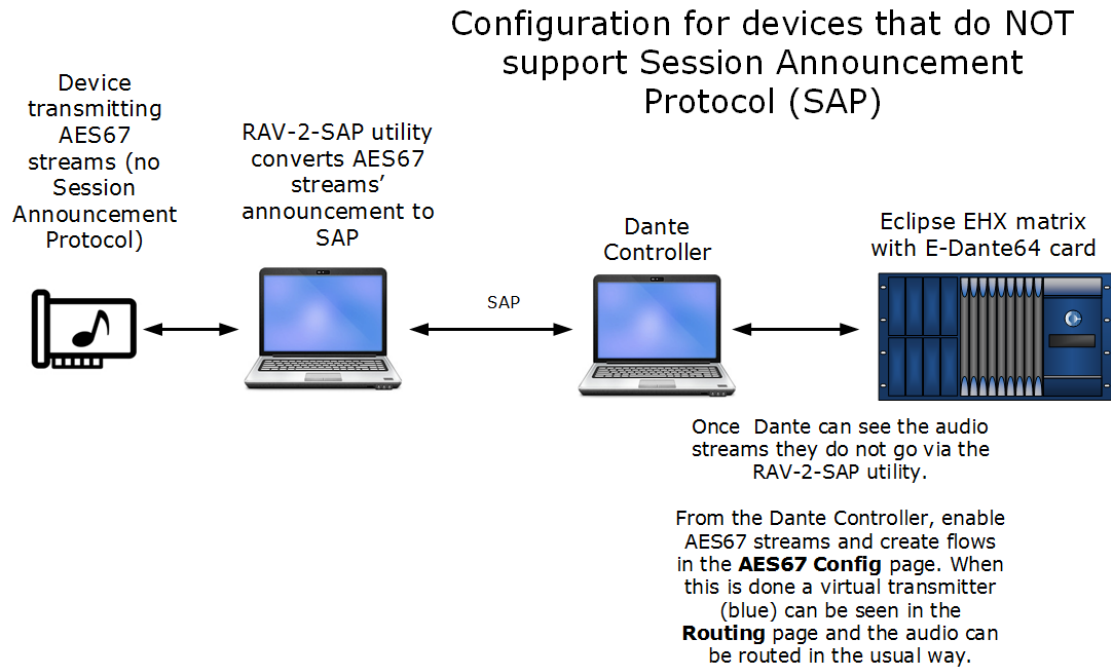

**Figure 11-7 Configuration for AES67 devices that do not support SAP**

## 12 E-IPA-HX high capacity IP to matrix card

The E-IPA-HX card is a high-capacity internet protocol (IP) audio card. It provides up to 64 connections.

The card offers both IVC ports and Clear-Com FreeSpeak II IP Transceiver (IPT) connectivity. This can be a combination of up to 64 IP ports or FreeSpeak II wireless beltpack connections (according to license).

IVC-32 functionality (V-series panels, Directs, LQ, and Agent-IC) runs at the same time as FSII beltpacks.

The E-IPA-HX card requires EHX software 10.0 and above.

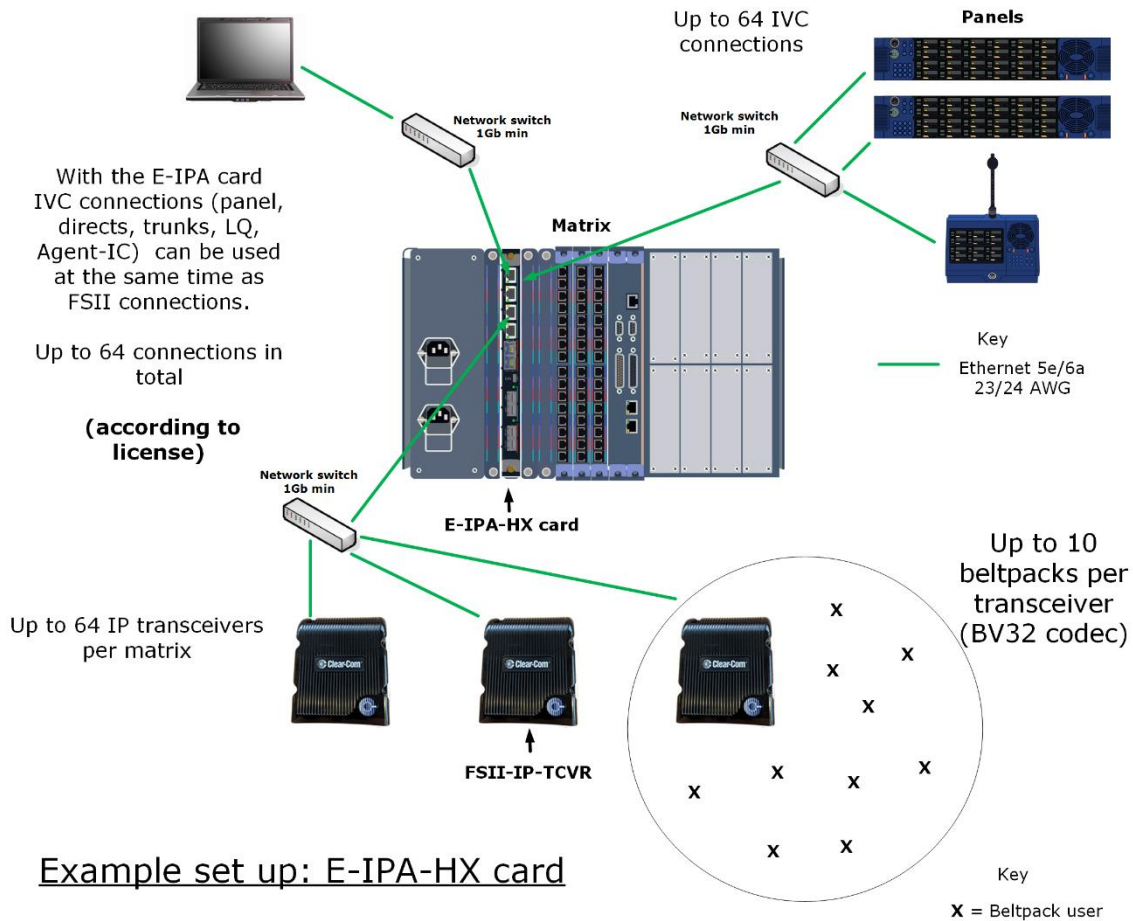

**Note:** The configuration of IP addresses when using the E-IPA card is important. See **12.7 Adding an E-IPA-HX card (automatic discovery)**

The E-IPA-HX card is automatically discovered when:

- You select the **Discover Hardware** option after the Matrix is placed on the **System Layout** from the discovery pane.
- You right-click a matrix on the **System Layout** screen, and then select **Configuration > Create New Configuration > Discover Hardware**.

## 12.1 Adding an E-IPA-HX card (manual)

To add an E-IPA-HX card:

- 4) In **Hardware > Cards and Ports**, navigate to an available slot number (marked **Empty**). Do either of the following:
  - Double click the slot.
  - Right click the slot and select **Set Card Type**.
- 5) A drop-down menu is displayed, listing the available card types. Select **E-IPA-HX**.
- 6) From the Card Properties screen, select the correct Port License.

It is not possible to have both E-IPA based FSII cards and EQue based FSII cards in the same Matrix. If you do so the following warning message appears:

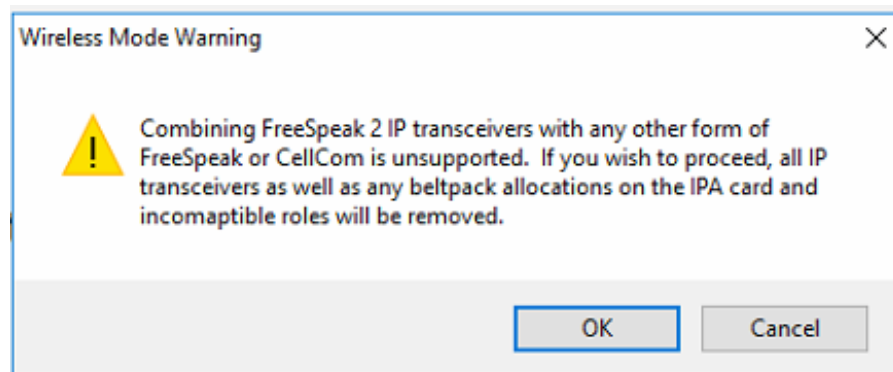

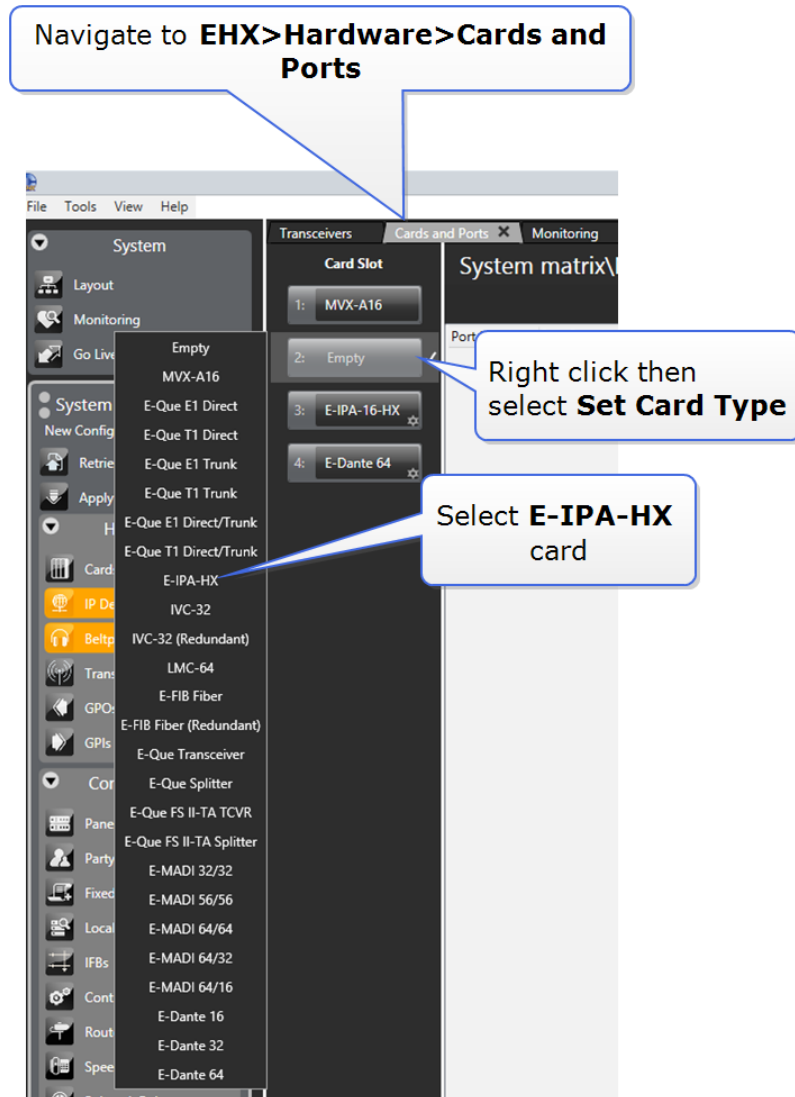

You can also use the **Detect New Hardware** feature in EHX to discover the card. Use this feature if the hardware is installed before the software is configured. This feature auto-detects the number of ports available on the card.

**Note:** When you add or remove a card in your configuration, the following message appears:

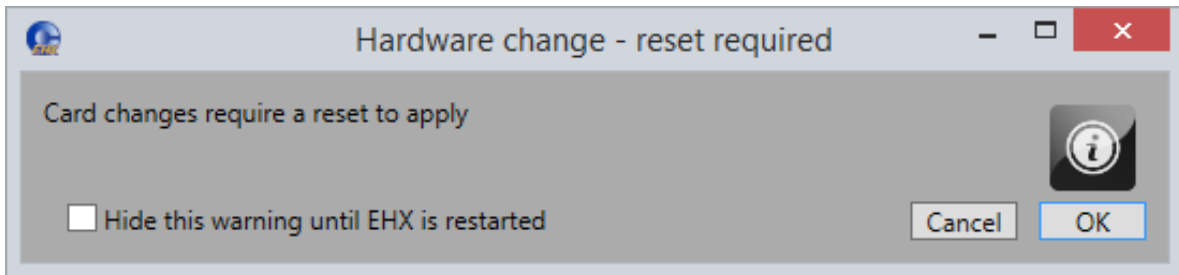

**Figure 12-1 Hardware change**

If your configuration contains linked matrices, the following message might appear when you apply changes to the matrix:

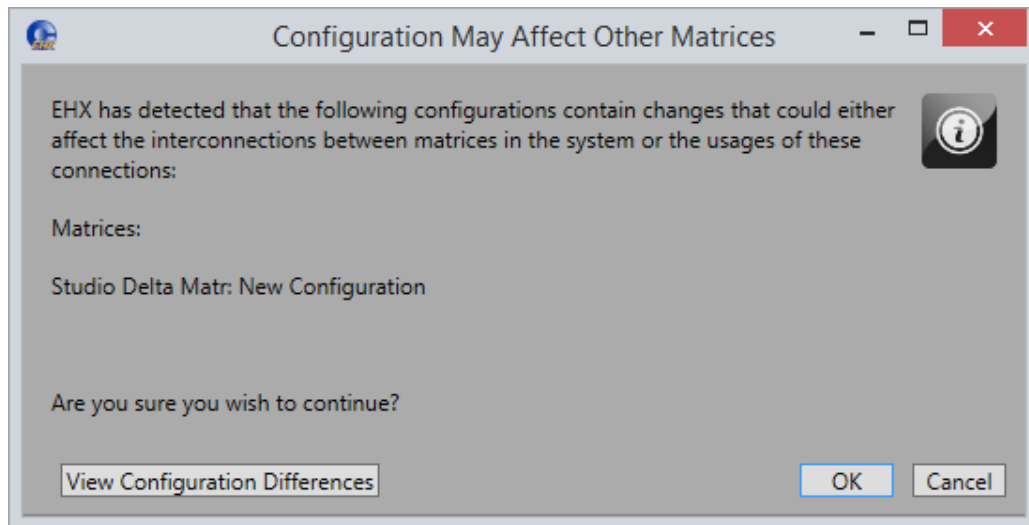

**Figure 12-2 Configuration may affect other matrices**

- 7) Click **View Configuration Differences** to see a list of possible interconnection issues.
- 8) Click **OK** to continue, or **Cancel**.
- 9) The E-IPA-HX Card Properties screen appears:

**Figure 12-3 E-IPA-HX Card Properties**

Change the edit fields as required, and then click **Close**.

**Note:** To view and edit the E-IPA-HX card properties at any time, double click on the E-IPA-HX Card Slot or right-click and select **Card Properties**.

After you have added a card, you can move it to another card slot as follows:

- 10) Right-click the card slot to be moved, and select **Move Card**.
- 11) Right-click the required empty card slot, and select **Paste Card (Move)**.

The card moves to its new position, and it maintains its configuration.

## 12.2 Network setup for the E-IPA-HX card

An E-IPA-HX card offers up to three available IP addresses. How these IP addresses are configured depends on how you intend to use the card.

The card properties dialog box indicates three different functions that can be spread over the 6 ports that are available on the back of the card.

- 12) Admin: Used, for example, for firmware upgrade or diagnostic data extraction.

- 13) IVC: V Series panels, Trunking, Directs, Agent-IC, LQ.
- 14) AES67: data and audio connection between the E-IPA-HX card and the IP Transceivers (IPTs).

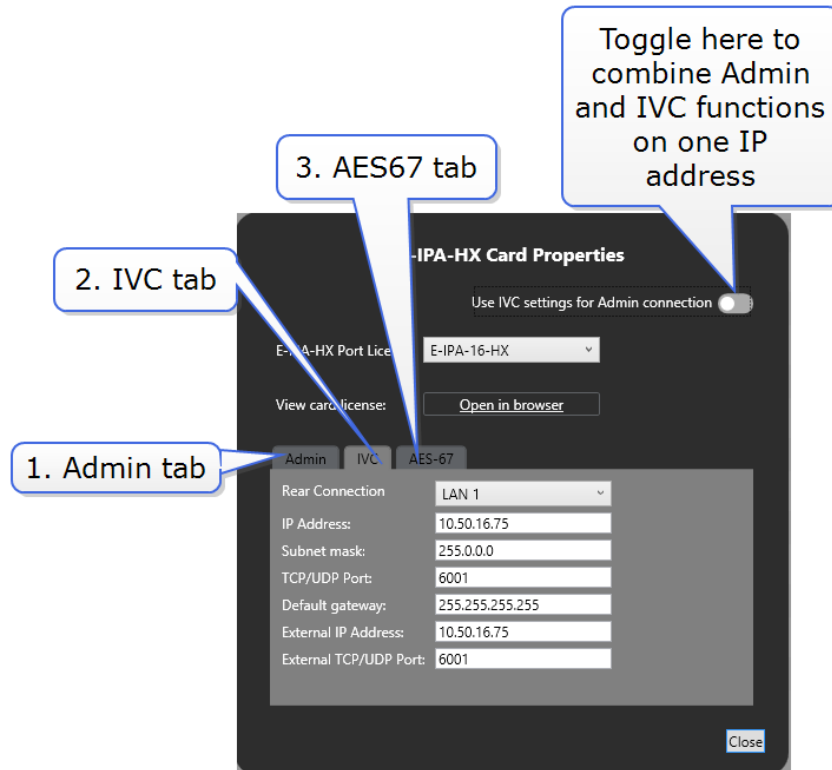

Functionality and IP ports can be combined, but Clear-Com recommends certain rules for set up to avoid loss of functionality and IP clashes.

### 12.2.1 Network setup for Clear-Com IVC functionality (V Series panels, Directs, Trunks, LQ and Agent-IC)

When configuring IVC functionality you must allocate a static IP address to this connection.

**Note:** You must configure the subnet mask to match your network topology when using a static IP address. Contact your network administrator for more information.

When using IVC functionality, the recommended setup is to combine IVC and administration functions on the same IP address (default setting).

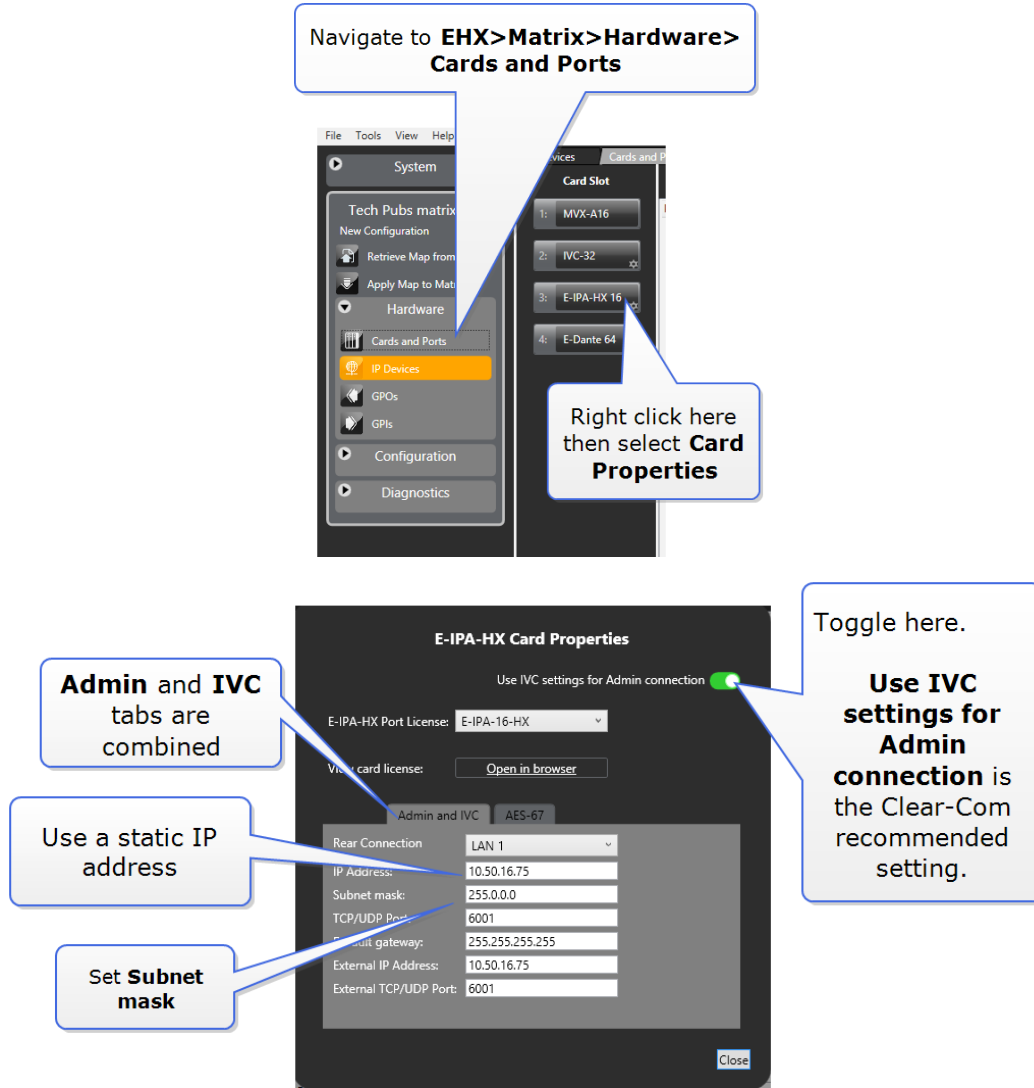

You can separate **Admin** from **IVC** connectivity, but if you do this, you must put administration functions and IVC functionality on separate subnets.

In this case, the Admin connection can be given a DHCP IP setting, while the IVC connection must have a static IP address.

### 12.2.2 Network setup for the FreeSpeak II IP Transceiver (IPT) with E-IPA-HX card

AES67 connections to the IPT can be on ports 1-6 (RJ45 or Fiber). Default: **LAN 3**.

- Clear-Com recommends that AES67 ports are on a separate network from the Admin and IVC ports.
- AES67 connections can work in the link-local range of IP addresses (169.254.XXX.XXX).
- When configuring an AES67 network, the network switch must have DiffServ Quality of Service (QoS) switched on.
- If the switch is capable of different profiles, select the standard AES67 profile.
- Internet Group Management Protocol (IGMP) snooping must be switched on and there must be an IGMP querier on the subnet.
- The network must be 1Gbps. A 100Mbps network does not support the amount traffic the card can generate.
- Multicast support must be enabled.
- If you use more than three switches between the PTP master and the slave, Boundary or Transparent clocks must be used.

**Warning:** When the IP address of the AES67 port changes, the E-IPA card automatically resets.

**E-IPA-HX Card Properties**

Use IVC settings for Admin connection

E-IPA-HX Port License: E-IPA-16-HX

View card license: [Open in browser](#)

Admin and IVC | **AES-67**

Rear Connection: LAN 3

DHCP Enabled:

IP Address: 169.254.10.107

Subnet mask: 255.255.0.0

Default gateway: 255.255.255.255

[Close](#)

Click here to configure a connection to a FreeSpeak IP transceiver

Select from ports 1 - 6. AES67 is usually configured on a separate LAN connection from Admin and IVC

If no DHCP server is present, a link-local address is allocated

**Note:** .

## 12.3 Licenses

The card operates on a license basis. You have the option to upgrade your card port capacity in increments of 16 ports. You can buy a card with a 16, 32, 48 or 64 port license.

Number of ports	Part number
16 ports	E-IPA-16-HX (1 x 16)
32 ports	E-IPA-32-HX (2 x 16)
48 ports	E-IPA-48-HX (3 x 16)
64 ports	E-IPA-64-HX (4 x 16)

16 additional ports	E-IPA-UG-16-HX
---------------------	----------------

**Note:** 64 ports in total per card is the maximum.

When you install a new card and use the **Detect New Hardware** feature in the EHX software, the software automatically detects the number of ports that are licensed on the card. You can also select the appropriate number of ports in **Card Properties**.

For how to obtain and install licenses see the *E-IPA Card Licensing Guide*.

The front lens of your card will always show how many ports you have licensed on that card.

## 12.4 Card capacity

Up to 64 IVC or FSII connections, according to license. Any combination of:

- V-series panels
- LQ, LQ SIP
- Agent-IC
- Directs
- Trunks
- Up to 64 IPTs and up to 64 FS II beltacks. Connecting an IPT does not remove any available ports, so there are potentially 64 ports that you can reserve for beltacks regardless of how many IPT are connected to the card.

Concert is NOT supported on the E-IPA-HX card.

### 12.4.1 How many E-IPA cards in a Clear-Com matrix?

- Clear-Com Omega and Median matrices: up to four E-IPA cards per matrix

- Clear-Com Delta matrix: up to three E-IPA cards per matrix

---

**Note:** This is an estimate for general guidance. For a more exact calculation, refer to the *Eclipse HX System Power Calculator* (Excel spreadsheet) that comes with your EHX firmware. You can find this spreadsheet in the **Documents** folder on the firmware DVD or USB.

---

## 12.5 E-IPA-HX rear connectors

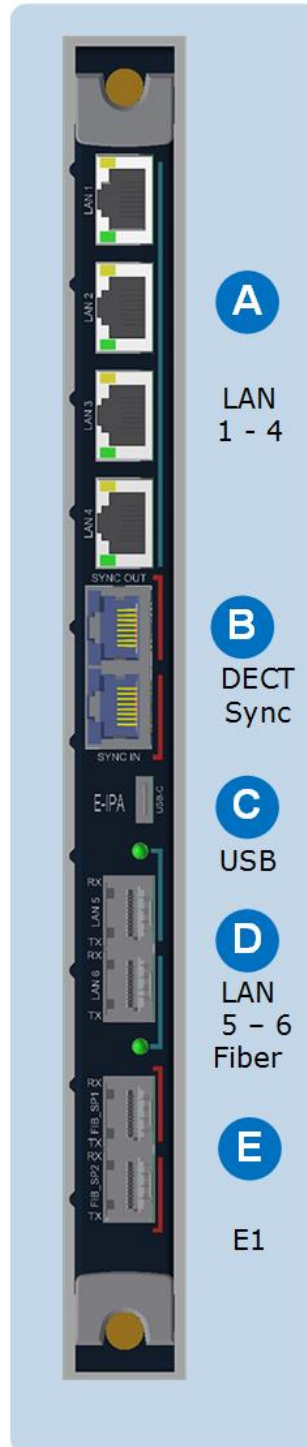





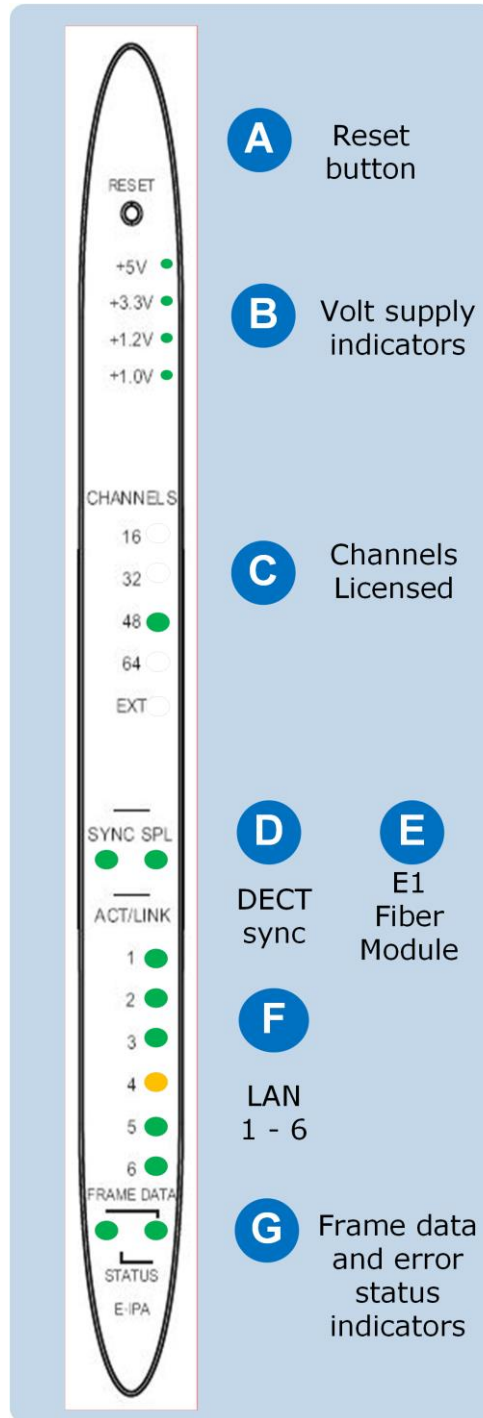

<p><b>A</b></p>	<p><b>RJ45 LAN ports 1 – 4.</b></p> <p>These can be used for: Clear-Com panels, directs, trunks, LQ, Agent-IC. They can also be used for FSII IP Transceivers. One of the ports can be designated as an ADMIN port and used for maintenance. The functionality of these ports is configured in the EHX software.</p> <p>Although there are 6 LAN ports on this card, only 3 IP addresses can be configured.</p>
<p><b>B</b></p>	<p><b>RJ45 DECT sync ports.</b></p> <p>These connectors can be used when you are using two separate DECT systems in the same area. Connecting the systems with the DECT sync connector ensures that all connected clocks are synchronized together. This avoids clashes when many DECT devices are in use in the same RF space.</p> <p>DECT sync can be established between matrices, bases and third party systems.</p> <p>See DECT Sync Pinouts in the FreeSpeak II User Guides.</p>
<p><b>C</b></p>	<p><b>USB C</b></p> <p>USB maintenance port.</p>
<p><b>D</b></p>	<p><b>LAN ports 5 and 6. Fiber, AES67 only.</b></p> <p>As with ports 1 – 4, the functionality of these ports is configured in the EHX software. They are designed to be used in AES67 networks for FSII IP transceivers.</p> <p>Although there are 6 LAN ports on this card, only 3 IP addresses are available.</p> <p>Use this slot to install an SFP/Mini-GBIC.</p>
<p><b>E</b></p>	<p><b>E1 Fiber ports (for future use)</b></p>

**Note:** The E-IPA card has four Media Access Control (MAC) addresses. These are printed on the card.

## 12.6 E-IPA-HX front lens indicators



	<p><b>Reset button</b></p> <p>This button is recessed to avoid accidental reset. Use a paperclip, or some appropriate item to reset the matrix.</p>
	<p><b>Volt supply indicators</b></p> <p>Normally, all these lights are lit, showing that the correct voltage is being supplied to the various card components.</p>
	<p><b>Channels licensed</b></p> <p>This indicates how many channels are licensed to the card. EXT is for future use.</p>
	<p><b>DECT sync</b></p> <p>This LED lights when a DECT-in sync connection is fitted to the card.</p>
	<p><b>E1 fiber connection to FSII splitter</b></p> <p>When lit, this shows a connection to an FSII splitter (for future use).</p>
	<p><b>LAN ports 1 – 6</b></p> <p>1 – 4 RJ45 LAN connections 5 – 6 Fiber LAN connections</p> <p>These lights show active links. They flicker and flash to indicate network traffic.</p> <p>An <b>amber</b> LED indicates 100Mbps connection. An LED lit <b>green</b> indicates 1Gbps connection. For FS II, Clear-Com does not recommend using less than 1Gbps in most circumstances, as 100Mbps only supports a small number of channels. A fiber connection is always 1Gbps and is always green.</p>
	<p><b>Frame data</b></p> <p>The Active (matrix data) LED flashes <b>green</b> at 1Hz to indicate communication between the E-IPA-HX card and the CPU card. This LED flashes twice as fast while a card is being upgraded and firmware is being installed.</p> <p><b>Status light Error LED</b></p> <p>Possible error conditions:</p> <ol style="list-style-type: none"> <li>1. Solid red light. Hardware fault (major issue).</li> </ol> <p>To diagnose other errors, see the EHX software event log.</p>

## 12.7 Adding an E-IPA-HX card (automatic discovery)

The E-IPA-HX card is automatically discovered when:

- You select the **Discover Hardware** option after the Matrix is placed on the **System Layout** from the discovery pane.
- You right-click a matrix on the **System Layout** screen, and then select **Configuration > Create New Configuration > Discover Hardware**.

## 12.8 Adding an E-IPA-HX card (manual)

To add an E-IPA-HX card:

- 15) In **Hardware > Cards and Ports**, navigate to an available slot number (marked **Empty**). Do either of the following:
  - Double click the slot.
  - Right click the slot and select **Set Card Type**.
- 16) A drop-down menu is displayed, listing the available card types. Select **E-IPA-HX**.
- 17) From the Card Properties screen, select the correct Port License.

It is not possible to have both E-IPA based FSII cards and EQue based FSII cards in the same Matrix. If you do so the following warning message appears:

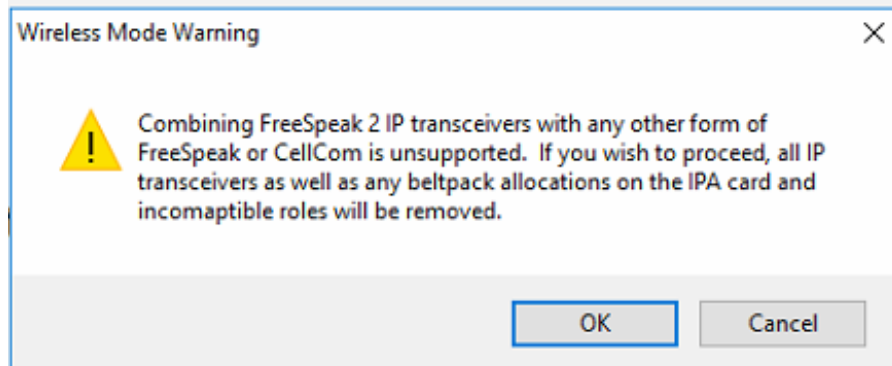

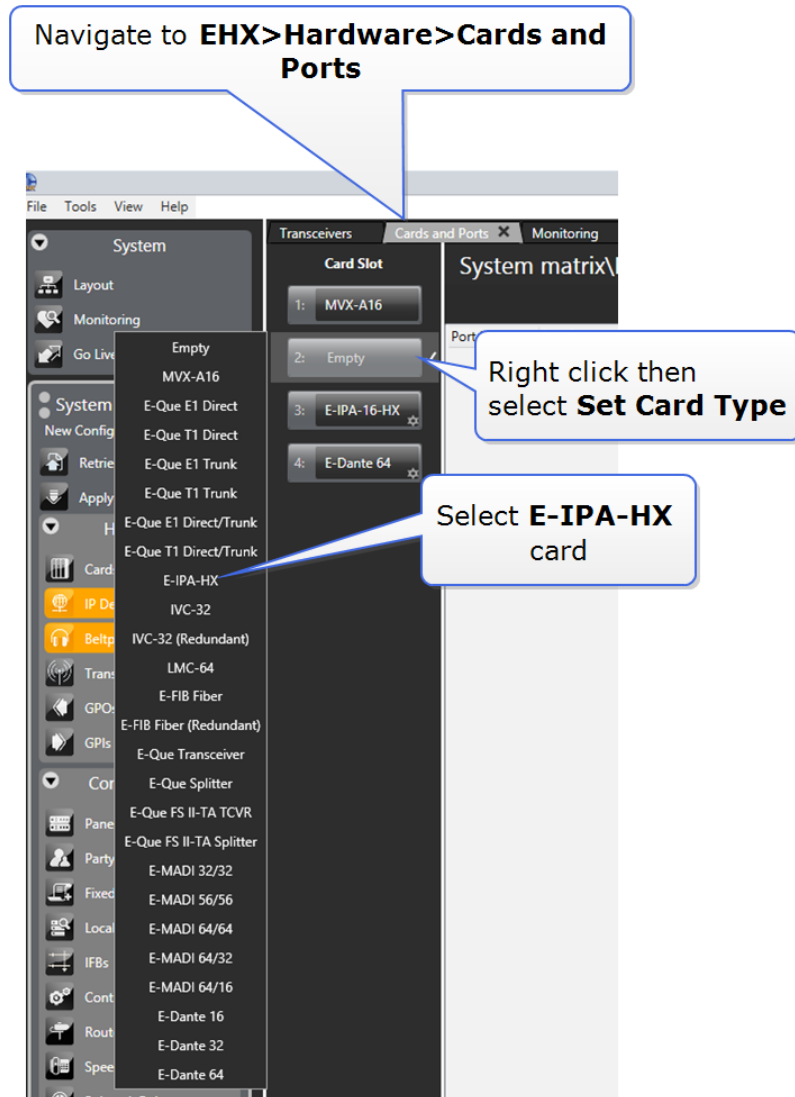

You can also use the **Detect New Hardware** feature in EHX to discover the card. Use this feature if the hardware is installed before the software is configured. This feature auto-detects the number of ports available on the card.

**Note:** When you add or remove a card in your configuration, the following message appears:

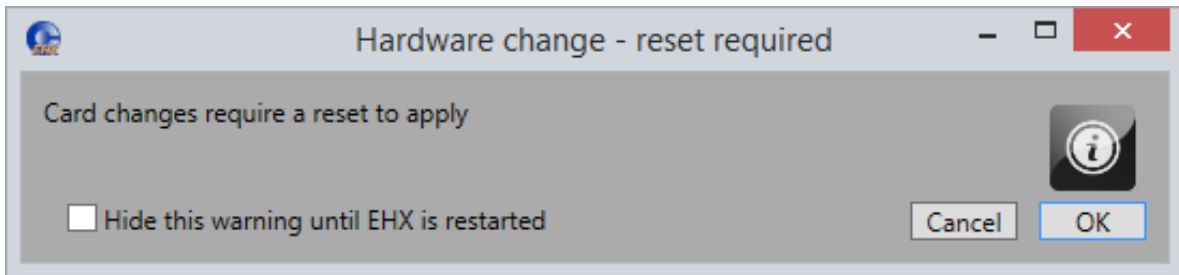

**Figure 12-1 Hardware change**

If your configuration contains linked matrices, the following message might appear when you apply changes to the matrix:

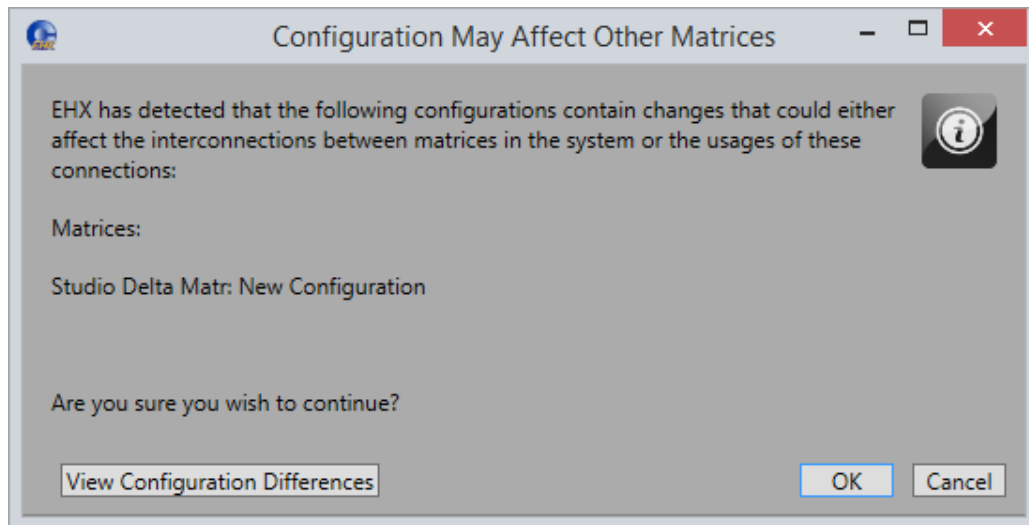

**Figure 12-2 Configuration may affect other matrices**

- 18) Click **View Configuration Differences** to see a list of possible interconnection issues.
- 19) Click **OK** to continue, or **Cancel**.
- 20) The E-IPA-HX Card Properties screen appears:

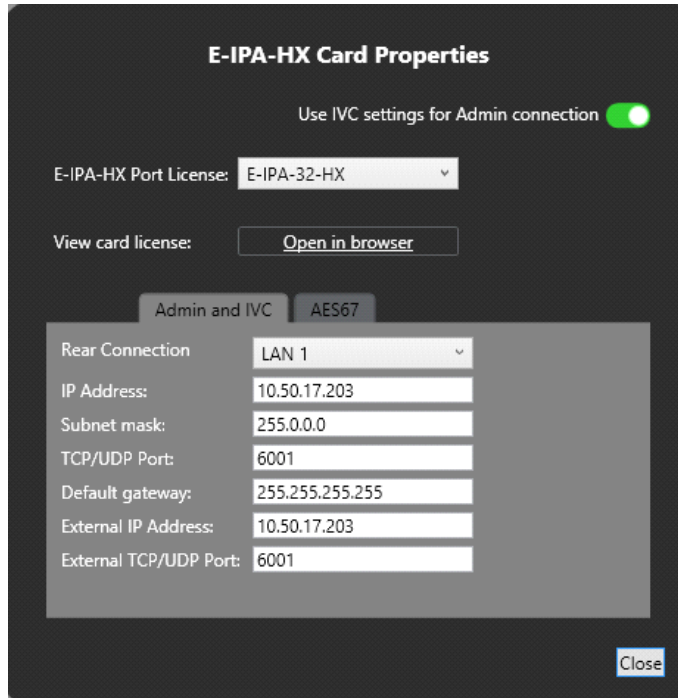

**Figure 12-3 E-IPA-HX Card Properties**

Change the edit fields as required, and then click **Close**.

**Note:** To view and edit the E-IPA-HX card properties at any time, double click on the E-IPA-HX Card Slot or right-click and select **Card Properties**.

After you have added a card, you can move it to another card slot as follows:

- 21) Right-click the card slot to be moved, and select **Move Card**.
- 22) Right-click the required empty card slot, and select **Paste Card (Move)**.

The card moves to its new position, and it maintains its configuration.

## 12.9 Network setup for the E-IPA-HX card

An E-IPA-HX card offers up to three available IP addresses. How these IP addresses are configured depends on how you intend to use the card.

The card properties dialog box indicates three different functions that can be spread over the 6 ports that are available on the back of the card.

- 23) Admin: Used, for example, for firmware upgrade or diagnostic data extraction.

- 24) IVC: V Series panels, Trunking, Directs, Agent-IC, LQ.
- 25) AES67: data and audio connection between the E-IPA-HX card and the IP Transceivers (IPTs).

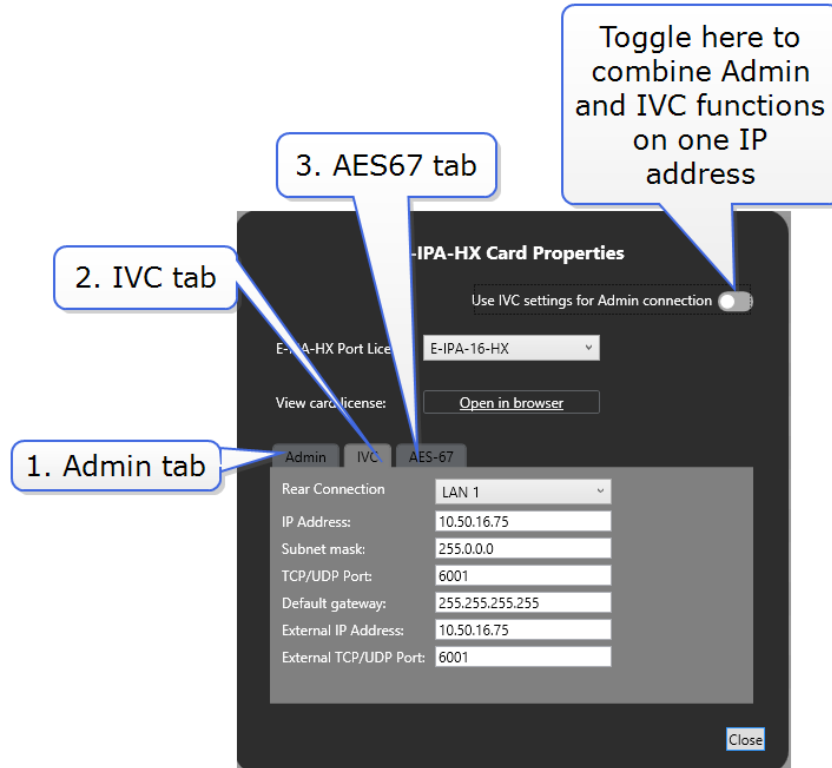

Functionality and IP ports can be combined, but Clear-Com recommends certain rules for set up to avoid loss of functionality and IP clashes.

### 12.9.1 Network setup for Clear-Com IVC functionality (V Series panels, Directs, Trunks, LQ and Agent-IC)

When configuring IVC functionality you must allocate a static IP address to this connection.

**Note:** You must configure the subnet mask to match your network topology when using a static IP address. Contact your network administrator for more information.

When using IVC functionality, the recommended setup is to combine IVC and administration functions on the same IP address (default setting).

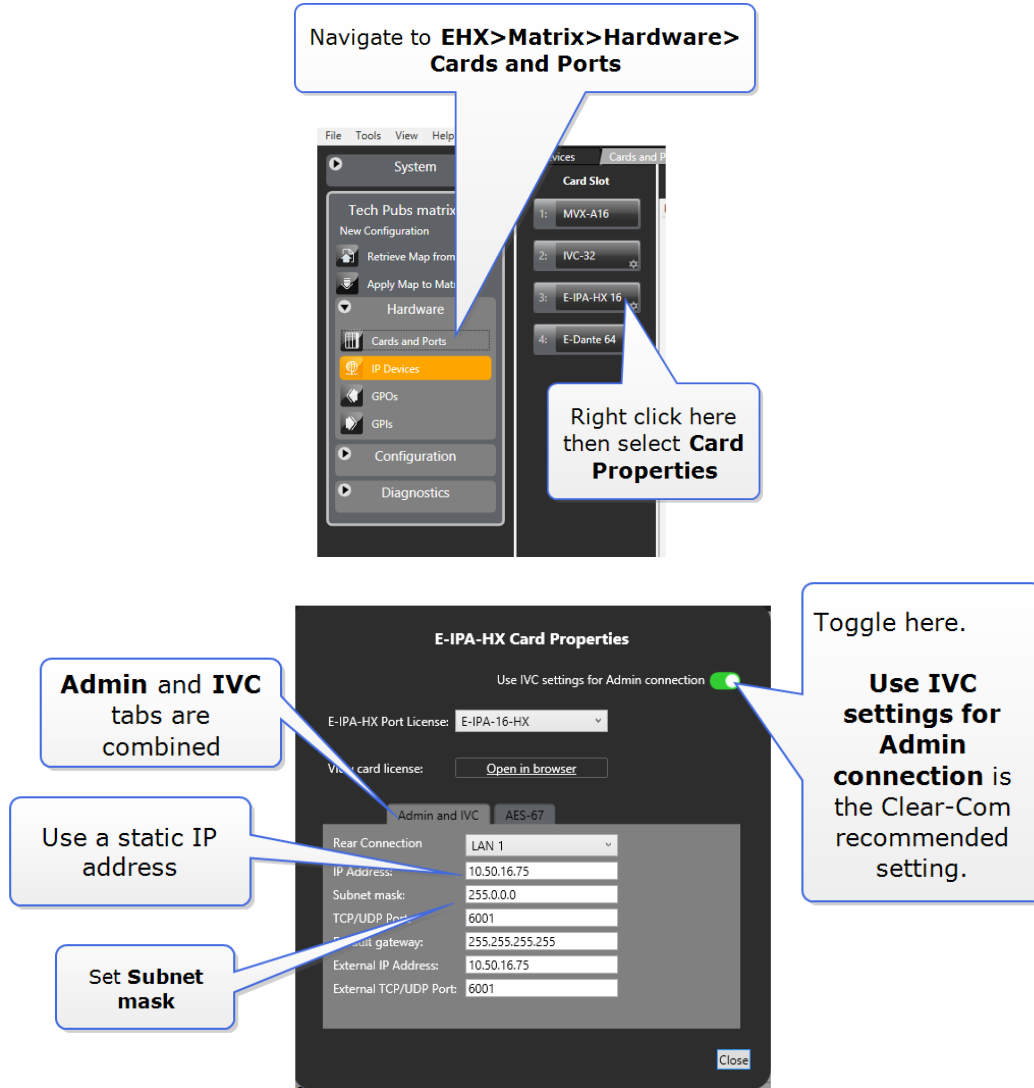

You can separate **Admin** from **IVC** connectivity, but if you do this, you must put administration functions and IVC functionality on separate subnets.

In this case, the Admin connection can be given a DHCP IP setting, while the IVC connection must have a static IP address.

### 12.9.2 Network setup for the FreeSpeak II IP Transceiver (IPT) with E-IPA-HX card

AES67 connections to the IPT can be on ports 1-6 (RJ45 or Fiber). Default: **LAN 3**.

- Clear-Com recommends that AES67 ports are on a separate network from the Admin and IVC ports.
- AES67 connections can work in the link-local range of IP addresses (169.254.XXX.XXX).
- When configuring an AES67 network, the network switch must have DiffServ Quality of Service (QoS) switched on.
- If the switch is capable of different profiles, select the standard AES67 profile.
- Internet Group Management Protocol (IGMP) snooping must be switched on and there must be an IGMP querier on the subnet.
- The network must be 1Gbps. A 100Mbps network does not support the amount traffic the card can generate.
- Multicast support must be enabled.
- If you use more than three switches between the PTP master and the slave, Boundary or Transparent clocks must be used.

**Warning:** When the IP address of the AES67 port changes, the E-IPA card automatically resets.

The screenshot shows the 'E-IPA-HX Card Properties' configuration window. At the top, there is a toggle for 'Use IVC settings for Admin connection' which is turned on. Below this, the 'E-IPA-HX Port License' is set to 'E-IPA-16-HX'. A 'View card license' button with 'Open in browser' text is present. The configuration is split into two tabs: 'Admin and IVC' and 'AES-67'. The 'AES-67' tab is active, showing 'Rear Connection' set to 'LAN 3', 'DHCP Enabled' checked, and IP settings: IP Address (169.254.10.107), Subnet mask (255.255.0.0), and Default gateway (255.255.255.255). A 'Close' button is at the bottom right. Three callout boxes provide additional information: one points to the 'Open in browser' button, another points to the 'Rear Connection' dropdown, and a third points to the 'DHCP Enabled' checkbox.

Click here to configure a connection to a FreeSpeak IP transceiver

Select from ports 1 - 6. AES67 is usually configured on a separate LAN connection from Admin and IVC

If no DHCP server is present, a link-local address is allocated

## 12.10 Port security settings

**Note:** All ports are closed by default, and the firewall is enabled. The following table lists the port security settings for the E-IPA-HX card.

Port	Setting
<b>Admin/IVC</b>	DHCP (67, 68)
	mDNS (5353)
	HTTP (80, 8080, 443)
	rsync (873)
	IVP (6001). IVP port is configurable.
<b>AES67</b>	DHCP (67, 68)
	PTP (319, 320)
	mDNS (53, 53)
	IVP (6001)
	HTTP (80, 80)

## 12.11 Upgrade the E-IPA-HX card

The E-IPA card must be upgraded from the EHX software.

The admin port of the E-IPA card must be on the same subnet as the PC hosting the EHX software.

**1. Tools > Apply firmware**

**2. Select Card**

**3. Navigate to where you have stored the file. The E-IPA upgrade file has a .tar.gz extension.**

**4. Click Download.** The upgrade process will take about 2.5 minutes. During upgrade the status light on the front card will flash at a rate of twice per second.

If there is an interruption to the power supply of the E-IPA-HX card during the upgrade, the card will go into recovery mode. The table below shows the stages that occur during recovery mode.

State \ LED	16	32	48	64	EXT1	EXT2	EXT3	EXT4	E1 1 & 2
<b>Erasing flash (~ 10 minutes)</b>	●	●							●
									●
<b>Writing preloader, u-boot and DTB</b>	●	●	●						●
									●

( < 1 minute)									
Writing zImage ( < 1 minute)	●	●	●	●					●
Writing FPGA image ( 1 minute)	●	●	●	●	●				●
Fetching rootfs ( ~ 10 seconds)	●	●	●	●	●	●			●
Writing rootfs ( < 5 minutes)	●	●	●	●	●	●	●		●
All done!	●	●	●	●	●	●	●	●	●

Check the firmware report to make sure that the upgrade has completed successfully.

## 13 Maintaining the Eclipse HX-Omega

---

The Eclipse HX-Omega matrix system connects a complex network of microprocessor controlled devices.

Due to the complexity of the system, field service should be limited to isolating a problem to the specific circuit board that may be causing the problem. Once the circuit board has been identified, it can be either repaired or replaced.

**Note:** For an overview of the Eclipse HX-Omega matrix, see **3 Overview** in this guide.



*Servicing instructions are for use by qualified personnel only. To reduce the risk of electric shock, do not perform any servicing other than that described by this guide, unless qualified to do so. Refer all servicing to qualified service personnel.*

### 13.1 Routine maintenance recommendations

#### 13.1.1 Cleaning the matrix)

Because the matrix has moving air in it, the entire matrix should be cleaned at least once a year. To clean the matrix, shut off AC power, remove all cards, and use compressed air to remove any dust buildup in the matrix itself. Clean all cards with a brush to remove dust buildup.



*Care should be taken not to induce a static discharge in the cards. Use of a grounding wrist strap is recommended. If a grounding wrist strap is not available, touch an unpainted metal surface on the matrix chassis periodically to neutralize static electricity.*

#### 13.1.2 Spare parts

To facilitate quick repair of the system with minimum downtime, Clear-Com recommends keeping the following spare system components in good working condition at all times:

- One CPU card.
- One CPU interface card.
- One Euro Cassette power supply module of the type fitted to the matrix.
- One of each type of intercom panel in the system.
- One of each type of interface in the system.

## 13.2 Fail-Safe modes

High reliability is one of the main objectives of the Eclipse HX-Omega system design. The following features of the system minimize the effects of a component failure.

### 13.2.1 Dual power supplies

The Eclipse HX-Omega matrix includes two Euro Cassette power supply units. One power supply unit can power an entire matrix; the second unit provides a backup in case of an equipment failure.

In addition, the two supplies have separate IEC connectors to AC mains power, and are designed for completely automatic and transparent changeover between supplies in the event of a power failure on one of the AC branches.



*To reduce the risk of electric shock, plug each of the power cords to separate branch circuits with different service ground.*

The power supplies contain an over-temperature sensor that is connected to both an audible alarm and a warning light, giving the system operator the necessary forewarning to diagnose and correct any power anomalies while the system remains operational.

If any individual power supply fails, an alarm can be issued to a remote location to alert operators that part of a power supply has failed. The failure of a single supply will issue an alarm, but the Eclipse HX-Omega system will continue to operate normally, powered by the second supply.

## 13.2.2 Hot patchability

All CPU cards, port cards, expansion cards, and all Euro Cassette power supplies are **hot patchable**— that is, they can be plugged in or removed from the matrix while the power is on, and they will be neither damaged, nor will they cause damage to the system.

In addition, the system smoothly incorporates a newly added card. Sometimes re-inserting a CPU card can reset the matrix. Replace CPU cards during maintenance down times if possible.

## 13.2.3 Onboard processors

If one analog port interface malfunctions, the malfunction will normally affect only the panels connected to that analog port interface. The malfunction should not affect any other cards or panels in the system. In all cases, removing a faulty card affects only the devices connected to that card.

## 13.2.4 Fail-Safe communication

In the event of a CPU card failure, the second CPU card takes over operation of the system, while the first card is repaired or replaced.

## 13.3 Troubleshooting

When attempting to identify the cause of the trouble, it is helpful to begin with the two most basic areas which cause malfunctions:

- The flow of electric current from the power supplies to the cards.
- The flow of data between the program software, the circuit cards, and the attached audio devices.

### 13.3.1 Troubleshooting power supply problems

Electric current in the matrix starts at the power supplies, travels through the matrix's backplane connectors, and then travels to the circuit cards themselves. When power-supply problems occur, those three areas (the power supplies, the backplane connectors, and the circuit card) should be explored to identify where the trouble is occurring.

The matrix's backplane connectors are part of the matrix's infrastructure and are not serviceable by field personnel. If it is determined that a problem is in the matrix's backplane connectors, the matrix must be returned for repair.

Backplane connector malfunctions are rare, but should be considered as possibilities.

**Note:** Clear-Com may ship a spare matrix to use while the damaged matrix is being repaired depending on the support status. For more information, see your warranty and support documentation.

### **Power supply lights on a component**

A lit power-supply light on a component indicates that the matrix's electric current has traveled successfully to that component and is powering the component. For example, if the power-supply lights on the CPU card are lit, the electric current has successfully traveled from the matrix's power supplies to the CPU card.

If a power-supply light is not lit on a component, the electric current has not reached that component for some reason. Knowing where the current has stalled helps to identify the component that needs repair.

For example, if all of the power-supply lights on all cards do not light, the electricity supply may have given out either in the power supplies themselves or in the matrix's backplane connectors. A faulty connector on the backplane, or a crack in the backplane can cause all of the matrix's power-supply lights to go out because the path on which the electric current is traveling has been blocked. This is a rare problem, but one to consider as a possibility. Repairing the problem in this case would involve determining whether the problem is in the power supplies or the backplane connectors. When a problem is identified in the power supplies or the circuit cards, the suspect component can be replaced with a properly functioning component to see if the problem is repaired.

### **Example power supply issues**

#### **Problem A: One or more power supply lights are unlit on one interface card**

Before repairing or replacing card, try to determine where the problem is occurring. One or both of the following actions can be tried:

#### **Action 1: Take the bad card out of the matrix, and insert it into a known good slot in the matrix.**

If the power supply lights still do not illuminate, the problem is probably in the card itself. Repair or replace the card.

If the power supply lights illuminate, the problem may be in the matrix's backplane connectors, which carry electric current from the power supplies to the cards. The matrix can be returned to Clear-Com for investigation or repair. In the meantime another matrix can be substituted for the damaged one.

**Note:** Clear-Com may ship a spare matrix to use while the damaged matrix is being repaired depending on the support status. For more information, see your warranty and support documentation.

**Action 2: Take a known good card, and insert it into the slot.**

If the power supply lights illuminate, the problem is probably in the card. Repair or replace the card.

If the power-supply lights do not illuminate, the problem may be in the matrix's backplane connectors, which carry electric current from the power supplies to the cards. The matrix can be returned to Clear-Com for investigation or repair. In the meantime, another matrix can be substituted for the damaged one.

**Note:** Clear-Com may ship a spare matrix to use while the damaged matrix is being repaired depending on the support status. For more information, see your warranty and support documentation.

Once the problem has been isolated to the card or the backplane, it is easier to take the next step which is to repair or replace the suspect component.

**Problem B: The power supply lights do not illuminate on any cards in the matrix.**

In this situation, the most probable problem is that the matrix's power supplies are not sending out any electric current, since none of the cards are receiving power. Although less likely, the problem may be in the matrix's backplane connectors.

**Action 1: Check the power supplies' alarm lights. If the power alarm lights are indicating a problem with the power supply, swap it out with a new power supply.**

If this repairs the problem, the problem was in the power supply.

**Action 2: If the problem persists even after the power supply has been replaced, the problem is in the matrix's backplane connectors.**

Send the matrix back to Clear-Com for repair or replacement. In the meantime another matrix can be substituted for the damaged one.

**Note:** Clear-Com may ship a spare matrix to use while the damaged matrix is being repaired depending on the support status. For more information, see your warranty and support documentation.

**Problem C: The power supply lights do not illuminate on one of the two CPU cards.**

When the system is functioning properly, the power-supply lights on both CPU cards illuminate. If the power-supply lights on a CPU card fail to illuminate, the problem may be with the card itself, or with the backplane connectors that carry the electric current from the power supplies to the cards. The backplane connectors are part of the infrastructure of the matrix and are not serviceable by field personnel.

**Action 1: Swap the CPU cards. Put the first card in the second CPU slot and the second card in the first CPU slot. The problem will follow the card or the slot.**

If the power supply lights do not illuminate on the bad card (the card with the lights out) when it is inserted in the other CPU slot, the problem is probably in the card.

If the power-supply lights on the bad card illuminate when the card is inserted in the other CPU slot, the problem is probably not in the card itself. The problem may be with the backplane connectors or power supplies.

**Action 2:** Check the power supplies' alarm lights. If the alarm lights are indicating a problem with the power supply, swap it out with a new power supply.

If this repairs the problem, the problem was in the power supply.

**Action 3:** If the problem persists even after the power supply has been replaced, the problem is in the backplane. Send the matrix back to Clear-Com for repair or replacement. In the meantime another matrix can be substituted for the damaged one.

**Note:** Clear-Com may ship a spare matrix to use while the damaged matrix is being repaired depending on the support status. For more information, see your warranty and support documentation.

**Problem D: The power supply lights are out on both CPU cards.**

The problem may be with power supplies, since both cards appear not to be receiving power. Although less likely, the problem may be in the matrix's backplane connectors.

**Action 1: Check the power supplies' alarm lights. If the alarm lights are indicating a problem with the power supply, swap it out with a new power supply.**

If this repairs the problem, the problem was in the power supply.

**Action 2:** If the problem persists even after the power supply has been replaced, the problem is in the backplane.

Send the matrix back to Clear-Com for repair or replacement. In the meantime another matrix can be substituted for the damaged one.

**Note:** Clear-Com may ship a spare matrix to use while the damaged matrix is being repaired depending on the support status. For more information, see your warranty and support documentation.

### 13.3.2 Troubleshooting data issues

The other type of problem that can occur in the system is when data is not flowing properly between the program software, the circuit cards, and the attached panels and interfaces. A troubleshooting sequence in this situation would be to first check cabling, then reset the card or panel, then reset the entire system.

#### **Analog port card (MVX-A16) RESET button**

Resetting the analog port interface causes the configuration information for the interface and its attached devices to reload to the interface from the CPU card's operational memory (located in its microprocessor's RAM), thus clearing up any corruption of data that may have occurred in the analog port interface microprocessor. The interface and all connected panels and interfaces momentarily stop their current activity and restart. The reset button must be pressed for more than two seconds to take effect.

If the entire system is operating except for one analog port interface, or one or more panels connected to the interface, press the reset button for that interface only.

This button is slightly recessed from the front panel to prevent it from being accidentally pressed. A tool such as a bent paper clip is required to press this button.

#### **CPU card RESET button**

When the CPU card is reset by pressing its reset button, the card's non-volatile RAM reloads all configuration information to the card's microprocessor. Resetting the card clears any corruption of data in the card's microprocessor. The card momentarily stops its current activity and restarts. The same system configuration that was active before the card was reset will be active after the reset.

The reset button is slightly recessed from the front panel to prevent it from being accidentally pressed. A tool such as a bent paper clip is required to press this button.

### **CPU card Full Reset button**

Press and hold the full-reset button and simultaneously press the reset button for the system to perform a cold restart. All cards in the matrix reset regardless of any system preferences in the program software. All audio devices connected to the cards, such as panels and interfaces, reset as well.

When the cards and connected audio devices reset, they momentarily stop their current activity and restart. During this process configuration information is downloaded to the port cards and connected audio devices from the CPU card's microprocessor.

The same system configuration that was active before the card was reset will be active after the reset. The button must be pressed for more than two seconds for the reset to take effect.

Under normal operating conditions it is not necessary to perform a full reset. Technical personnel might perform a full restart if they believe that the CPU card is operating incorrectly as a result of corruption of the microprocessor's internal data or instruction sequence.

### **Example data issues**

**Problem A:** A port light on an analog port interface does not illuminate, although there is a panel attached to that port.

**Action 1:** Check the panel and the wiring leading to it.

**Action 2:** Check the Matrix Data light. If there is no indication of matrix communication to this interface while the other interfaces in the matrix are communicating, **reset the interface**.

**Action 3:** Replace the interface cards.

**Action 4:** Replace the panel.

**Problem B:** Audio sounds low or distorted from a panel.

**Action 1:** Check the matrix's currently active CPU card's power lights. If any of the lights are not lit, replace the card.

**Action 2:** Check the analog port input and output gain settings for the port in EHX.

**Action 3:** Check the panel's listen-level adjustment settings in EHX.

## 13.4 System block diagram

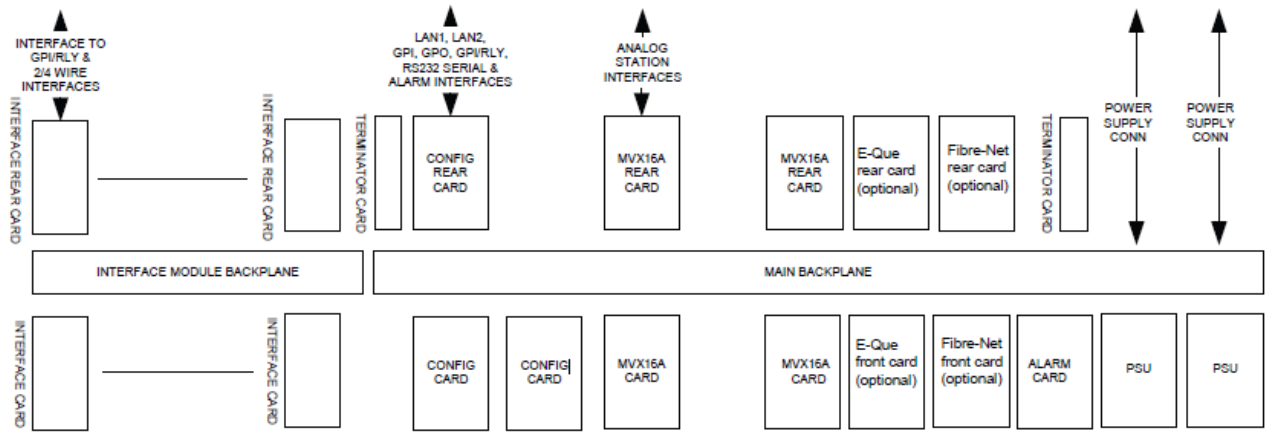

Figure 13-1: System block diagram

## 14 Compliance

---

- Applicant Name: Clear-Com LLC
  - Applicant Address: 1301 Marina Village Pky, Suite 105, Alameda CA 94501, USA
  - Manufacturer Name: HM Electronics, Inc.
  - Manufacturer Address: 14110 Stowe Drive, Poway, CA 92064, USA
  - Country of Origin: USA
- 
- Brand: CLEAR-COM
  - Product name: Digital Matrix System
  - Product Regulatory Model Number: Eclipse HX-Omega
  - Country of Origin: USA
- 
- Brand: CLEAR-COM
  - Product name: Interface Card
  - Product Regulatory Model Number: IC0XX (where X can be any alphanumeric character 0-9, A-Z). All IC0XX SELV interface cards are compliant with regulatory requirements detailed in this document when installed correctly in Clear-Com product per Clear-Com specifications.

Caution: Product modification not expressly approved by the party responsible for compliance can void the user's authority to operate the equipment

### **FCC Class A**

This device complies with part 15 of the FCC Rules. Operation is subject to the following two conditions: (1) This device may not cause harmful interference, and (2) this device must accept any interference received, including interference that may cause undesired operation.

NOTE: This equipment has been tested and found to comply with the limits for a Class A digital device, pursuant to part 15 of the FCC Rules. These limits are designed to provide reasonable protection against harmful interference when the equipment is operated in a commercial environment. This equipment generates, uses, and can radiate radio frequency energy and, if not installed and used in accordance with the instruction manual, may cause harmful interference to radio communications. Operation of this equipment in a residential area is likely to cause harmful interference in which case the user will be required to correct the interference at his own expense.

### **Canada ICES-003**

Industry Canada ICES-003 Compliance Label: CAN ICES-3 (A)/NMB-3(A)

This Class A digital apparatus complies with Canadian ICES-003.  
Cet appareil numérique de la classe A est conforme à la norme NMB-003 du Canada.

### **European Union ( CE )**



#### ***Directives:***

EMC Directive 2014/30/EU

Low Voltage Directive 2014/35/EU

#### ***Standards:***

EN55022

EN55024

EN55032

### **Korea KCC EMC Registration**

#### **For Class A Equipment**

이 기기는 업무용(A급) 전자파 적합기기로서 판매자 또는 사용자는 이 점을 주의하시길 바라며, 가정 외의 지역에서 사용하는 것을 목적으로

### **Waste Electrical and Electronic Equipment (WEEE)**

The European Union (EU) WEEE Directive (2012/19/EU) places an obligation on producers (manufacturers, distributors and/or retailers) to take-back electronic products at the end of their useful life. The WEEE Directive covers most Clear-Com products being sold into the EU as of August 13, 2005. Manufacturers, distributors and retailers are obliged to finance the costs of recovery from municipal collection points, reuse, and recycling of specified percentages per the WEEE requirements.

#### **Instructions for Disposal of WEEE by Users in the European Union**

The symbol shown below is on the product or on its packaging which indicates that this product was put on the market after August 13, 2005 and must not be disposed of with other waste. Instead, it is the user's responsibility to dispose of the user's waste equipment by handing it over to a designated collection point for the recycling of WEEE. The separate collection and recycling of waste equipment at the time of disposal will help to conserve natural resources and ensure that it is recycled in a manner that protects human health and the environment. For more information about where you can drop off your waste equipment for recycling, contact your local authority, your household waste disposal service or the seller from whom you purchased the product.

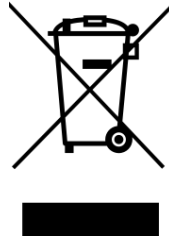

**Figure 14-1: WEEE Symbol**

## 15 Specifications

**Note:** 0 dBu is referenced to 0.775 volts RMS.

### 15.1 Matrix capabilities

Category	Number / Comments
<b>Maximum Expansion Cards</b>	15
<b>Ports per MVX Port Card</b>	16
<b>Maximum MVX Port Cards</b>	15
<b>Maximum CPU Cards</b>	2 (included)
<b>Maximum Fiber Expansion Cards</b>	2
<b>Maximum E-Que Cards</b>	<p>A total of four E-Que, IVC-32 or LMC-64 interface cards may be fitted to an Eclipse HX-Omega unless the matrix is fitted with a Power-One PSU. If the matrix has a Power-One PSU, up to six E-Que, IVC-32 or LMC-64 cards may be fitted with the following condition:</p> <ul style="list-style-type: none"> <li>You can only have four E-Que cards with EM signaling enabled.</li> </ul> <p>Fitting a fan tray is recommended when you have more than four E-Que, IVC-32 or LMC-64 cards.</p> <p>A power calculator for the matrix is provided with the documentation.</p> <p>The EHX system software will not allow the user to create a configuration that exceeds the power limits of the Power One PSU.</p>
<b>Maximum Power Supply Units</b>	2 (included)
<b>Maximum RJ-45 Ports per Matrix</b>	240 (15 MVX port cards)
<b>Maximum Expansion Cards</b>	15

Table 15-1: Matrix capabilities

## 15.2 Mechanical

Category	Measures / comments
<b>Height</b>	10.6 inches (267 mm or 6 RU)
<b>Width</b>	19 inches (482 mm)
<b>Depth</b>	16 inches (410 mm)
<b>Front Card Depth</b>	300 mm
<b>Weight</b>	20 to 35 kg

Table 15-2: Mechanical

## 15.3 Environmental

Category	Measures / comments
<b>Operating Temperature</b>	0° C to +40° C, ambient
<b>Storage Temperature</b>	-55° C to +70° C
<b>Humidity, Maximum</b>	90% non-condensing

Table 15-3: Environmental

## 15.4 Matrix performance

Category	Measures / Comments
<b>Sample Rate</b>	48 kHz
<b>Resolution</b>	24 bit
<b>Frequency Response @ 48 kHz sampling</b>	30 Hz – 22 kHz $\pm$ 3 dBu
<b>Crosstalk (adjacent channel)</b>	<-70 dBu
<b>Nominal Level</b>	0 dBu
<b>Matrix headroom</b>	+18 dBu
<b>Distortion</b>	<0.05 %, @ 0 dBu, 300 Hz to 10 kHz; <0.1 %, @ 0 dBu, 100 Hz to 20 kHz
<b>Off Noise</b>	<-70 dBu (20 Hz - 22kHz)
<b>On Noise</b>	<-65 dBu (20 Hz - 22 kHz)
<b>Key Response, Intra-System</b>	<40 ms for audio route

Table 15-4: Matrix capabilities

## 15.5 E-MADI64 interface front card

Category	Measures / comments
<b>Height</b>	6RU
<b>Depth</b>	300 mm
<b>Operating Temperature</b>	0° C to +40° C
<b>Storage Temperature</b>	-55° C to +70° C
<b>Humidity</b>	40 - 90% non-condensing
<b>Power (combined cards)</b>	+3.3V 1.5A

Table 15-5: E-MADI64 interface front card

## 15.6 E-MADI64 interface rear card

Category	Measures / comments
Height	6RU
Depth	58mm (max)
Operating Temperature	0° C to +40° C
Storage Temperature	-55° C to +70° C
Humidity	40 - 90% non-condensing
Power (combined cards)	+3.3V 1.5A

Table 15-6: E-MADI64 interface rear card

## 15.7 E-MADI64 fiber cable

Category	Measures / comments
Fiber cable	Multimode 62.5/125µm
Coaxial cable	75ohm

Table 15-7: E-MADI64 fiber cable

## 15.8 E-MADI64 fiber transceiver

Category	Measures / comments
Type	Multimode SFP Transceiver
Wavelength	1310nm
Connector	Duplex LC
Standard Max Node Length	2km (other distances (achieved using the optional single mode fiber module) are available to special order.)

Table 15-8: E-MADI64 fiber transceiver

The standard multimode fiber module is a **Class 1 LED Product**. The optional single mode fiber module is a **Class 1 Laser Product**.

## 15.9 E-MADI64 clock sources

Clock type	Clock source
<b>Word Clock</b>	44.1KHz
	48KHz
	96KHz
<b>SD Video</b>	NTSC
	PAL
<b>HD Tri-Level Sync</b>	720P60
	720P59.94
	720P50
	720P30
	720P27.97
	720P25
	720P24
	720P23.98
	1080P60
	1080P59.94
	1080P50
	1080P30
	1080P29.97
	1080P25
	1080P24
	1080P23.98
	1080I30
	1080I29.97
	1080I25
	1080I24
1080I23.98	

Table 15-9: E-MADI64 clock sources

## 15.10 Fiber interface front card

Category	Measures / comments
Height	6RU
Depth	300 mm
Operating Temperature	0° C to +40° C
Storage Temperature	-55° C to +70° C
Humidity	40 - 90% non-condensing
Power	+3.3V

Table 15-10: Fiber interface

## 15.11 Fiber interface rear card

Category	Measures / comments
Height	6RU
Depth	58mm (max)
Operating Temperature	0° C to +40° C
Storage Temperature	-55° C to +70° C
Humidity	40 - 90% non-condensing
Power	+3.3V

Table 15-11: Fiber interface

## 15.12 Fiber cable

Category	Measures / comments
Cable type	Single Mode 9/125μ

Table 15-12: Fiber interface

## 15.13 Fiber transceiver

Category	Measures / comments
Type	SR1 Short Range SFP Transceiver Minimum Power Budget
Wavelength	1310nm

<b>Connector</b>	Duplex LC
<b>Standard Max Node Length</b>	10km Note: <i>Other distances are available to special order.</i>

**Table 15-13: Fiber transceiver**

## 15.14 E-Que interface front card

Category	Measures / comments
Height	6RU
Depth	300 mm
Operating Temperature	0° C to +40° C
Storage Temperature	-55° C to +70° C
Humidity	40 - 90% non-condensing
Power (combined cards)	+3.3V 3.5A +5V 0.7A +12V 0.05A

Table 15-14: E-Que interface front card

## 15.15 E-Que interface rear card

Category	Measures / comments
Height	6RU
Depth	58 mm (max)
Operating Temperature	0° C to +40° C
Storage Temperature	-55° C to +70° C
Humidity	40 - 90% non-condensing

Table 15-15: E-Que interface rear card

## 15.16 IVC-32 interface front card

Category	Measures / comments
Height	6RU
Depth	300 mm
Operating Temperature	0° C to +40° C
Storage Temperature	-55° C to +70° C
Humidity	40 - 90% non-condensing

<b>Power (combined cards)</b>	+3.3V 3.5A
	+5V 0.7A
	+12V 0.05A

**Table 15-16: IVC-32 interface front card**

## 15.17 IVC-32 interface rear card

Category	Measures / comments
<b>Height</b>	6RU
<b>Depth</b>	58 mm (max)
<b>Operating Temperature</b>	0° C to +40° C
<b>Storage Temperature</b>	-55° C to +70° C
<b>Humidity</b>	40 - 90% non-condensing

Table 15-17: IVC-32 interface rear card

## 15.18 LMC-64 interface front card

Category	Measures / comments
<b>Height</b>	6RU
<b>Depth</b>	300 mm
<b>Operating Temperature</b>	0° C to +40° C
<b>Storage Temperature</b>	-55° C to +70° C
<b>Humidity</b>	40 - 90% non-condensing
<b>Power (combined cards)</b>	+3.3V 3.5A +5V 0.7A +12V 0.05A

Table 15-18: LMC-64 interface front card

## 15.19 LMC-64 interface rear card

Category	Measures / comments
Height	6RU
Depth	58 mm (max)
Operating Temperature	0° C to +40° C
Storage Temperature	-55° C to +70° C
Humidity	40 - 90% non-condensing

Table 15-19: LMC-64 interface rear card

## 15.20 E-DANTE64-HX interface front card

Category	Measures / comments
Height	6RU
Depth	300 mm
Operating Temperature	0° C to +40° C
Storage Temperature	-55° C to +70° C
Humidity	40 - 90% non-condensing
Power (combined cards)	+3.3V 2.2A

## 15.21 E-DANTE64-HX interface rear card

Category	Measures / comments
Height	6RU
Depth	300 mm
Operating Temperature	0° C to +40° C
Storage Temperature	-55° C to +70° C
Humidity	40 - 90% non-condensing
Power (combined cards)	+3.3V 2.2A

## 15.22 E-Dante64-HX LAN connectors

Category	Measures / comments
<b>RJ45</b>	RJ45 ports are 100/1000 MB
<b>Fibre</b>	To be fitted with an SFP (Small Form-factor Pluggable) Mini-GBIC (Gigabit Interface Converter), available from Clear-Com. See table below.

## 15.23 E-Dante64-HX SFP modules

Category	Measures / comments
<b>DA-MMFO-1G-SX</b>	Multi-mode 1GBps SX Fiber module
<b>DA-SMFO-1G-LX</b>	Single-mode 1 GBps LX Fiber module

**Note:** Select transceivers to match your required cable type and network infrastructure. As a general rule, the DA-MMFO-1G-SX module can be used for shorter distances, while the DA-SMFO-1G-LX module will provide a longer range (depending on existing cabling).

## 15.24 E-Dante64-HX sample rates and available channels

Category	Measures / comments
<b>Channels</b>	Up to 64. Select from 16, 32 and 64
<b>Sample rates</b>	44.1, 48 and 96 kHz. Using 96 kHz limits the channels that can be used to 32.

## 15.25 E-IPA-HX card

Category	Measures / comments
Height	6RU
Depth	300 mm
Operating Temperature	0° C to +40° C
Storage Temperature	-30° C to +70° C
Humidity	20 - 90% non-condensing
Power	+3.3V 4.75A +5V 0.77A +12V 0.18A

## 15.26 Analog port cards (MVX-A16) (MK1 and MK2)

Category	Measures / comments
Height	6 RU
Depth	300 mm
Audio Interface	16, bi-directional
Input Format	Balanced
Output Format	Balanced
Ground Isolation	None; expected at User Panel/Station
<b>Analog port card outputs</b>	
Level	0 dBu nominal/18 dBu max.
Impedance	100 Ohms balanced
Frequency Response	30 Hz–22 kHz ± 3 dB
Distortion	<0.05 %, @ 0 dBu, 300 Hz to 10 kHz; <0.1 %, @ 0 dBu, 100 Hz to 20 kHz
<b>Analog port card inputs</b>	
Level	0 dBv nominal/18 dBu max.
Impedance : card Mark 1.	600 Ohms balanced
Impedance : card Mark 2.	>10K Ohms balanced

<b>Frequency Response</b>	30 Hz–22 kHz $\pm$ 3 dB
<b>Distortion</b>	<0.05 %, @ 0 dBu, 300 Hz to 10 kHz; <0.1 %, @ 0 dBu, 100 Hz to 20 kHz

Table 15-20: Analog port cards (MVX-A16) (Cards no. 1 & 2. Note difference in input impedance.)

## 15.27 Data interface: 16 bi-directional

Category	Measures / comments
<b>Input Format</b>	RS-422 @ 2400 to 19200 kb/s
<b>Output Format</b>	RS-422 @ 2400 to 19200 kb/s
<b>Input Termination</b>	100 ohm $\pm$ 10%
<b>Output Termination</b>	None; expected at User Panel
<b>Isolation</b>	None; expected at User Panel

Table 15-21: Data interface: 16 bi-directional

## 15.28 Backplane connector: FCI/BERG Metral

Category	Measures / comments
<b>Port Connector</b>	RJ-45 to Clear-Com standard pinout
<b>Transmission Distance</b>	3000 ft. (1000 m) maximum

Table 15-22: Data interface: 16 bi-directional

## 15.29 System programming

Category	Measures / comments
<b>Group Calls</b>	100
<b>Number of Grouped Ports</b>	4000 maximum
<b>Conferences per Matrix</b>	199
<b>IFB per Matrix</b>	100
<b>Priority Levels</b>	5
<b>Isolates</b>	Any crosspoint

<b>Listen Level Control</b>	0.71 dB steps
<b>Input Level Control</b>	0.355 dB steps
<b>Output Level Control</b>	0.355 dB steps
<b>VOX Input Detection Threshold</b>	0 dB to - 45 dB adjustable

Table 15-23: System programming

## 15.30 Minimum PC requirements (for EHX software)

Specification	Description / Value
<b>Processor</b>	1 GHz
<b>Memory</b>	1GB RAM
<b>Hard disk</b>	1GB minimum 32 bit, 2GB minimum 64 bit.
<b>Input devices</b>	CD-ROM drive
<b>Display resolution</b>	SVGA
<b>User entry</b>	Keyboard, Mouse
<b>Ports</b>	2 serial ports and/or network IEEE 802.3 Ethernet card
<b>Network</b>	IEEE 802.3 Ethernet card
<b>Operating systems</b>	<p>EHX 8.5.1 runs on the following versions of Windows:</p> <ul style="list-style-type: none"> <li>• Microsoft Windows 7 (32-bit and 64-bit).</li> <li>• Microsoft Windows 8.1 (32-bit and 64-bit)</li> <li>• Microsoft Windows 10 (32-bit and 64-bit)</li> <li>• Microsoft Windows Server 2008 R2 (64-bit)</li> <li>• Microsoft Windows Server 2012 R2 (64-bit)</li> </ul> <p>Operation on other platforms is no longer supported.</p>

Table 15-24: Minimum PC requirements

## 15.31 Recommended PC requirements (for EHX software)

Specification	Description / Value
<b>Processor</b>	2GHz or greater for a client. As many cores as possible for a server.
<b>Memory</b>	2GB for client 32 bit. 4GB for client 64 bit. 3GB for server 32 bit. 4GB+ for server 64 bit.
<b>Free space</b>	1GB minimum 32 bit. 2GB minimum 64 bit.
<b>Display resolution</b>	1600 x 1200
<b>Operating systems</b>	EHX 7.6 runs on the following versions of Windows: <ul style="list-style-type: none"> <li>• Microsoft Windows 7 (32-bit and 64-bit).</li> <li>• Microsoft Windows 8.1 (32-bit and 64-bit)</li> <li>• Microsoft Windows 10 (32-bit and 64-bit)</li> <li>• Microsoft Windows Server 2008 R2 (64-bit)</li> <li>• Microsoft Windows Server 2012 R2 (64-bit)</li> </ul> <p>Operation on other platforms is no longer supported.</p>

**Table 15-25: Recommended PC requirements**

**Note:** For more information, see your EHX documentation.

## 15.32 Power supply unit

Category	Measures / comments
<b>Format</b>	Euro Cassette
<b>Quantity</b>	2 per matrix
<b>Mounting</b>	Front
<b>Backplane Connectors</b>	Positronics
<b>AC Power Input</b>	IEC (1 per PSU)
<b>Input Voltage</b>	AC 100 V to 240 V, 50/60 Hz
<b>Power Consumption</b>	300 W Maximum
<b>Status Indicators</b>	LEDs viewable from front of rack

**Table 15-26: Power supply unit**

**Note:** While Clear-Com makes every attempt to maintain the accuracy of the information contained in its product manuals, this information is subject to change without notice.

Performance specifications included in this manual are design-center specifications and are included for customer guidance only and to facilitate system installation. Actual operating performance may vary.

## 16 Glossary

Term	Definition
<b>Analog Port</b>	<p>Any of the Eclipse HX matrix's analog input/output RJ-45 connectors that are used to connect cable from the matrix to panels and interfaces.</p> <p>Each port connects to a separate audio channel in the matrix.</p>
<b>Alias label</b>	<p>A label that is temporarily assigned and replaces a previously labeled port or conference.</p>
<b>Bus</b>	<p>A bus is the channel or path between the components in the matrix along which electrical signals flow to carry information from one component to the next.</p> <p>In the Eclipse HX matrix the bus is located in the etched surface of the midplane.</p>
<b>Call signal</b>	<p>A call signal is an electronic signal sent from one panel or interface to another. A call signal can be audible and/or visual. Typically a call signal is sent to get the attention of a panel operator who may have turned down their intercom speaker's volume or removed their headset. It can also be sent to activate an electronic relay.</p>
<b>Canvas</b>	<p>The assignment area of the Production Maestro software which can have any user labeled background.</p>
<b>Category-5 (CAT-5) cable</b>	<p>EIA/TIA 568 category specification relating to network cabling. Shielded category-5 cabling is required for Eclipse HX matrix wiring.</p>
<b>CellCom<sup>®</sup></b>	<p>Digital wireless communications product. Sold under the CellCom name in USA and as FreeSpeak in Europe and Asia.</p>

<b>Central matrix</b>	<p>The term <b>central matrix</b> is used to differentiate the central hardware and software of the intercom system from the connected audio devices. The central matrix consists of:</p> <ul style="list-style-type: none"> <li>• The metal housing for the circuit cards and power supplies.</li> <li>• The circuit cards.</li> <li>• The power supplies.</li> <li>• The rear panel connectors which connect the matrix's hardware to panels and interfaces.</li> </ul>
<b>Conference</b>	An internal matrix virtual partyline or busbar where many panels and interfaces can talk onto or listen from the party line without talking to themselves.
<b>Destination</b>	A device such as an intercom panel, beltpack, or interface to which audio signals are sent. The device from which audio signals are sent is called a <b>source</b> .
<b>Duplex</b>	All real-time communication between individuals talking face to face is full duplex, meaning that they can both talk and listen simultaneously. The Eclipse HX matrices provide full-duplex audio.
<b>E-DANTE64-HX</b>	A matrix interface card that is enabled to work with Dante network protocols and software, allowing you to transport many channels of high quality audio via a Clear-Com matrix to multiple Dante enabled devices using standard Ethernet network structure (up to 64 channels per E-DANTE64 card). Dante enabled devices are also AES67 compliant.
<b>EHX</b>	EHX is the Eclipse HX configuration software. EHX guides the operation of the matrix circuit cards and connected panels.
<b>Ethernet</b>	International standard which describes how information is transmitted across a network. Provides for the efficient organization of network components.

<b>Fiber optic cable</b>	A fiber-optic cable consists of a glass core covered with a reflective material called <b>cladding</b> and several layers of buffer coating to protect the cable from the environment. A laser sends light pulses through the glass core to the other end of the cable.
<b>FreeSpeak®</b>	Digital wireless communications product. Sold under the FreeSpeak name in Europe and Asia and CellCom name in USA.
<b>FreeSpeak II™</b>	Digital wireless communications product.
<b>Full duplex</b>	Refers to transmission of signals in two directions simultaneously.
<b>Hopping</b>	Refers to making a trunk connection through other matrices to a destination matrix.
<b>IFB</b>	<p><b>Interruptible Foldback.</b> The term <b>foldback</b> refers to sending program audio / feed, or some other audio mix, back to announcers while they are on the air. Doing so allows announcers to monitor themselves, other announcers, videotapes of commercials, or some mix of sources, while they on the air. This is typically found in television news and live broadcast events.</p> <p>Announcers typically wear a small ear piece so they can hear the selected foldback audio mix. When a director wants to give directions to an announcer on air, or to announce changes in the program, the director must <b>interrupt</b> the foldback. To do this, the director uses a channel specifically set up to interrupt the foldback audio.</p>
<b>Interface module</b>	A piece of electronic hardware designed to convert the 4-wire signals of a central matrix port to some other form of communication, such as 2-wire partyline, telephone, etc. The interface module is connected to a central matrix port. The external non-4-wire device is then connected to the interface module.
<b>i-Series</b>	<p>The i-Series is a family of Eclipse HX-supported user panels.</p> <p>The series includes two display stations, two non-display stations, two expansion panels, and a level-control panel.</p> <p>Eclipse HX also supports V-Series panels (see below).</p>

<b>ISO</b>	The ISO function, short for <b>panel ISolation</b> , allows a panel operator to call a destination and interrupt all of that destination's other audio paths and establish a private conversation. When the call is completed the destination's audio pathways are restored to their original state before the interruption.
<b>Keygroup</b>	KeyGroups provide a way of assigning a label to multiple panels simultaneously even within a networked matrix system. Once the KeyGroups have been defined using EHX, all the keys within a KeyGroup can be changed with a single assignment in Production Maestro (Pro mode only).
<b>Label</b>	A label is an alphanumeric name of up to five characters that identifies a source, destination, or control function accessed by an intercom panel. Labels appear in the displays of the intercom panel.  Labels can identify panels, ports interfaced to other external equipment, fixed groups, party lines, and special control functions.
<b>MADI</b>	Multichannel Audio Digital Interface. The MADI or AES10 electronic communications protocol defines the data format and electrical characteristics of an interface carrying multiple channels of digital audio.
<b>Multiplexing</b>	The process by which two or more signals are transmitted over a single communications channel. Examples include time division and wavelength division multiplexing.
<b>Non-volatile Memory</b>	Data stored in the CPU's firmware (ROM) that is not lost when the power is turned off.
<b>Palette</b>	The port, keyGroup and Monitor selection screen in Production Maestro.
<b>Panel</b>	Any intelligent intercom device connected to the rear-panel analog ports of the central matrix. This term does not refer to devices connected through interface modules.
<b>Partyline</b>	A wired shared communication system based on a single screened pair of wires. See the Encore range. Matrix requires the CCI-22 to interface to it.

<b>Port</b>	Any of the input/output connections (RJ-45 connectors) on the back panel of the central matrix. These connectors and the attached cables connect the central matrix to remote intercom devices. The term <b>port</b> emphasizes that the connection is a portal between the central matrix and the remote intercom devices.
<b>Program</b>	Any separate audio source that is fed into the intercom channels. In television applications, for example, the program audio is the audio that is broadcast on air.
<b>Rack Unit (RU)</b>	Standardized unit of mounting space on a rack panel. Each rack unit is 1.75 inches (44.45 mm) of vertical mounting space. Therefore 1 RU is 1.75 inches (44.45 mm) of vertical mounting space, 2 RU is 3.5 inches (88.9 mm), 3 RU is 5.25 inches (133.35mm), and so on.
<b>Remote panel</b>	Any intelligent intercom device connected to the back-panel ports of the matrix. This term does not refer to devices connected through interfaces.
<b>Sidetone</b>	The sound of the panel operator's voice, as heard in their own earphone(s) as they speak.
<b>Source</b>	In this guide, the term source refers to a device (such as an intercom panel, interface, or beltpack) that sends audio into the matrix. The device to which audio is sent is called a destination.
<b>VOX</b>	In the Eclipse HX system, when audio at a panel exceeds a threshold, a light switches on at the panel's port card to visually cue the operator. The threshold level is set in the EHX configuration software.
<b>V-Series</b>	User panels used with Eclipse HX systems, providing advanced intercom facilities. Available in rack mount and desktop formats.  i-Series user panels are also supported (see above).