

THE HENSLEY ARROW
INSTALLATION and
OPERATION MANUAL

IMPORTANT: KEEP THIS MANUAL IN THE TRAILER.

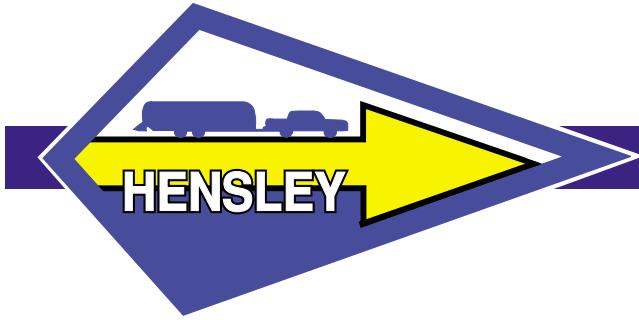

HENSLEY MFG., INC.

1097 S. State Road • Davison, MI 48423

810-658-0006 • 1-800-410-6580

Welcome to the Family of Hensley Arrow™ Owners,

Thank you for purchasing the Hensley Arrow™ towing system. This system has been engineered to make your towing experience the most pleasurable possible.

Since the Hensley Arrow™ is intended to be a lifetime investment, we encourage you to become thoroughly familiar with this Installation and Operation Manual. It is designed to provide you with the information you will need to successfully maintain and operate your new towing system. If you do encounter a problem the manual does not cover, we are only a telephone call away.

Please follow the written instruction when installing your Hensley Arrow™. If you have any questions, give us a call on 1-800-410-6580.

Sincerely,
HENSLEY SALES

Colin Connell
PRESIDENT

STOP MAIL IN YOUR WARRANTY TODAY

WARNING: RETURN OF WARRANTY REGISTRATION IS A CONDITION PRECEDENT TO WARRANTY COVERAGE IF THE FORM IS NOT RECEIVED COMPLETED AS DIRECTED, YOU WILL NOT HAVE A WARRANTY.

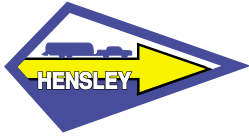

HENSLEY ARROW WARRANTY REGISTRATION

Please read the following information carefully. After you have read the notice, please sign your name on the space provided.

WARNING

The Hensley Arrow™ towing system attaches to the trailer tongue. It is rated for a maximum tongue weight of 1,400 lbs and gross weight of the trailer (including the load) of 14,000 lbs.

The towing vehicle and the vehicle hitch that is the connecting mechanism that includes the ball platform and other components that extend and attach to the towing vehicle, are both separately rated for maximum tongue weight and gross weight of the trailer (including the load).

Refer to the manufacturer of your vehicle and your vehicle hitch for the maximum tongue weight and gross weight of your towing vehicle and vehicle hitch.

Do not exceed the maximum of your towing vehicle, your vehicle hitch or the Hensley Arrow™ towing system.

I have read the above warning and understand its content.

Date: _____

Signature _____

To activate your lifetime warranty, please read and fill out the following information and return this card to:

Hensley Mfg., Inc 1097 S. State Road, Davison, MI 48423

Please print the following information 🖨️

Serial # _____

Serial # is on the nameplate on the main unit.

Name _____

Address _____

City _____ State _____ Zip _____

Hme PH: _____ Wrk PH: _____

HENSLEY ARROW HITCH BAR ORDER FORM

Please Print the following information and send your order to :
Hensley Mfg., Inc 1097 S. State Road, Davison, MI 48423
 or fax your order to: 810-653-4468

NAME: _____ PH: _____

ADDRESS _____

CITY _____ STATE _____ ZIP _____

VISA/MASTERCARD _____

EXPIRATION DATE: _____

TOW VEHICLE: _____ TRAILER _____

(i.e. 1/2T SUB, 3/4T PU, Car etc..) (i.e. Jayco, AWARD, Airstream)

The following measurements will help us to determine which hitch bar to ship to you.
 To measure for the hitch bar, your tow vehicle and trailer need to be on a level surface.

1. With the vehicle running, measure the number of inches from parking surface to the inside top of the 2" square receiver box.

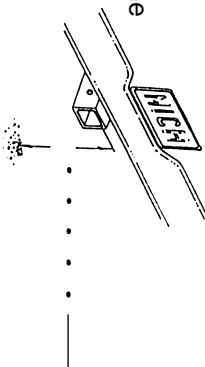

2. Circle the letter for which type of coupler is on your trailer.



3. With the trailer level, measure the number of inches from the top of the trailer coupler to the parking surface.

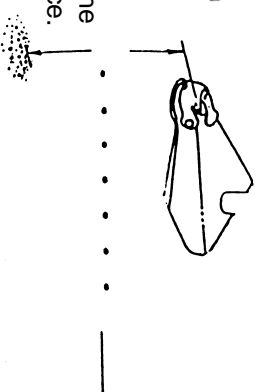

NOTE: The top of the ball of the Hensley Arrow™ is approximately 5 1/2" above the top of the hitch bar.

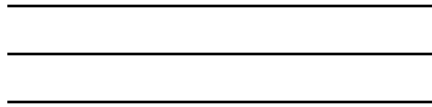

NO POSTAGE
NECESSARY
IF MAILED
IN THE
UNITED STATES

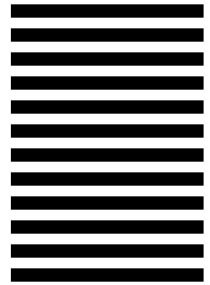

BUSINESS REPLY MAIL
FIRST CLASS MAIL PERMIT NO 14 DAVISON MI

POSTAGE WILL BE PAID BY ADDRESSEE

HENSLEY MFG., INC.

1097 S. State Road
Davison, MI 48423

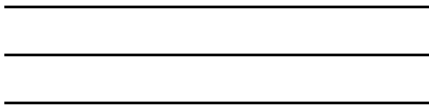

NO POSTAGE
NECESSARY
IF MAILED
IN THE
UNITED STATES

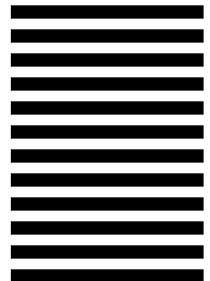

BUSINESS REPLY MAIL
FIRST CLASS MAIL PERMIT NO 14 DAVISON MI

POSTAGE WILL BE PAID BY ADDRESSEE

HENSLEY MFG., INC.

1097 S. State Road
Davison, MI 48423



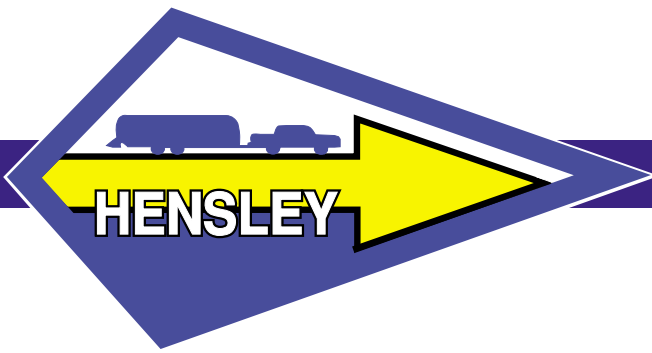

GUARANTEES2

LIFETIME WARRANTY3

INSTALLATION5

 Parts List6

 Installation Instructions8

 Installation of Frame Brackets10

 Installation of Jacks12

 Installation of Spring Bars14

 Installation of Strut Assemblies16

 Strut Adjustment17

 Tensioning of Spring Bars18

HOOK-UP PROCEDURES21

UNHOOKING27

MORE HITCH HINTS28

MAINTENANCE29

INSPECTION30

EXCHANGE CLUB31

QUICK REFERENCE HOOKING & UNHOOKING33-34

FREQUENTLY ASKED QUESTIONS35-36

GUARANTEES



60 DAY MONEY BACK GUARANTEE

With your purchase of the Hensley Arrow,TM you receive a 60 day unconditional money back guarantee.

If, for any reason, you are not completely satisfied with your Hensley ArrowTM, you may return it for a full refund.

HENSLEY GUARANTEES YOUR SATISFACTION

As a Hensley ArrowTM owner, you have become a part of our extended family. It is important to us that you receive prompt, courteous assistance with your Hensley ArrowTM.

Hensley Mfg., Inc. leads the hitch industry in quality, innovation, reliability and performance. Our 60 day unconditional money back guarantee demonstrates our commitment to you. We stand behind our products' quality and YOU.

This means that every step of the way, from your first telephone call, through purchase and delivery, to after-sales service, we're committed to the spirit as well as the letter of our guarantee.

This is the Hensley way of doing business. It's as simple as a smile, a handshake, and a promise kept.

RETURNS: 60 DAY MONEY BACK GUARANTEE

- In order to process your return, please call 1-800-410-6580 and ask for our Customer Relations Manager.
- Reimbursement for return merchandise will be issued 7-10 business days after the product, including all original parts and packing slip, has been received by Hensley Mfg., Inc.

LIFETIME WARRANTY

THE HENSLEY LIFETIME LIMITED WARRANTY

As an original owner of the Hensley Arrow™ advanced towing system, you receive a lifetime limited warranty on all parts and service.

What Is Covered

The Lifetime Limited Warranty period begins upon receipt of signed Hensley Arrow™ warranty registration card.

The Lifetime Warranty is limited to the original purchaser of the Hensley Arrow™ advanced towing system. The Lifetime Warranty is non-transferrable.

This warranty covers repair or replacement to any Hensley Arrow™ part (not manufactured by others) that is defective in materials or workmanship under normal use.

Warranty items should be returned to Hensley Mfg., Inc. for inspection. (See page 32 for shipping address.)

Customer is responsible for all freight charges associated with warranty work.

What is Not Covered

- A) Items added or changed after the unit left the possession of Hensley Mfg., Inc.
- B) Any use of the Hensley Arrow™ for rental or other commercial purposes.
- C) Normal wear and usage, such as fading or discoloration of painted parts.
- D) Minor imperfections which do not affect the suitability of the Hensley Arrow™ for its intended use.
- E) Costs incurred as the result of the consumer's request to have repairs performed, or replacement of parts supplied by other than Hensley Mfg., Inc. without proper notification or authorization by Hensley Mfg., Inc.
- G) This warranty does not apply to or cover any component which has its own warranty by its manufacturer.

Note:

This product, like your tow vehicle, requires proper care and maintenance. Failure to provide the proper care and maintenance, or to observe the proper handling and use of the Hensley Arrow™, will result in damage to the product. Instructions regarding care and maintenance and proper usage of the Hensley Arrow™ are contained in the Owner's Manual and Supplement Manuals which accompany this product.

It is important that if a defect is noted, the owner notifies Hensley Mfg., Inc. and complies with the instructions for correction of the defect. Failure to notify Hensley Mfg., Inc. or to comply with corrections given about damage to the hitch, may cause further damage that is not covered under this warranty.

LIFETIME WARRANTY

**THIS LIMITED WARRANTY GIVES YOU SPECIFIC LEGAL RIGHTS,
AND YOU MAY ALSO HAVE OTHER RIGHTS
WHICH VARY FROM STATE TO STATE**

**NOTICE:
EXCEEDING MAXIMUM CAPACITY CREATES A SAFETY HAZARD
14,000 lb. max - Gross Trailer Weight Rating
1,400 lb. max - Tongue Weight Rating**

The Hensley Arrow™ towing system attaches to the trailer tongue. It is rated for a maximum tongue weight of 1,400 lbs and gross weight of the trailer (including the load) of 14,000 lbs.

The towing vehicle, and the vehicle hitch receiver, that is, the connecting mechanism which includes the ball platform and other components that extend and attach to the towing vehicle, are both separately rated for maximum tongue weight and gross weight of the trailer (including the load).

Refer to the manufacturer of your vehicle and your vehicle hitch receiver for the maximum tongue weight and gross weight of your towing vehicle and vehicle hitch receiver.

Do not exceed the maximum of your towing vehicle, your vehicle hitch receiver or the Hensley Arrow™ towing system.

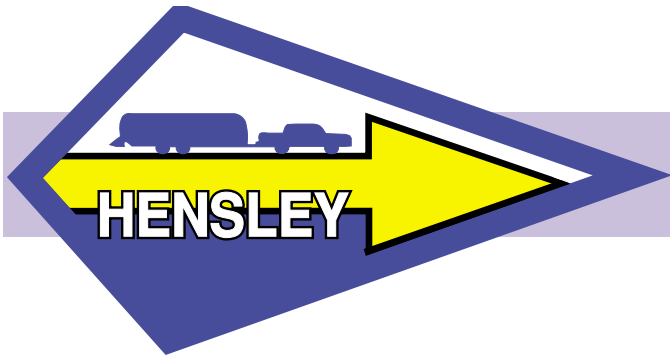

INSTALLATION

Parts List and Required Tools	6
Installation Instructions	8
Installation of Frame Brackets	10
Installation of Jacks	12
Installation of Spring Bars	14
Installation of Strut Assemblies	16
Strut Adjustment	17
Tensioning Spring Bars	18
Frequently Asked Questions	35-36

PARTS LIST

- 1 MAIN HITCH ASSEMBLY
- 2 OCL (Over Center Latch)
- 3 HITCH BOX
- 4 OCL ADJUSTABLE SCREWS
- 5 HITCH BAR
- 6 SAFETY KEYS
- 7 HITCH BAR PIN & SAFETY CLIP
- 8 OCL WRENCH
- 9 JACK ASSEMBLY (Adjustable)
- 10 SPRING BARS
- 11 STRUT ASSEMBLY
- 12 FRAME BRACKET
- 13 SPRING BAR U-BRACKET
- 14 U-BOLTS (Frame Bracket)
- 15 U-BOLTS PLATES
- 16 HITCH BALL
- 17 RACHET WRENCH
- 18 DRILL BIT ($19/64$ ")
- 19 SELF-TAPING SHEAR BOLTS ($5/16$ ")

REQUIRED TOOLS

TORQUE WRENCH

11/16" DEEPWELL SOCKET

5/32" ALLEN WRENCH

SCREW DRIVER OR CRESENT WRENCH

TAPE MEASURE GREASE GUN

DRILL MOTOR MULTI-PURPOSE

BEARING GREASE

TORQUE CONVERSION CHART

45ft lbs.	=	61 Newton Meters
	=	540 inch lbs
	=	6.2 meters kilograms

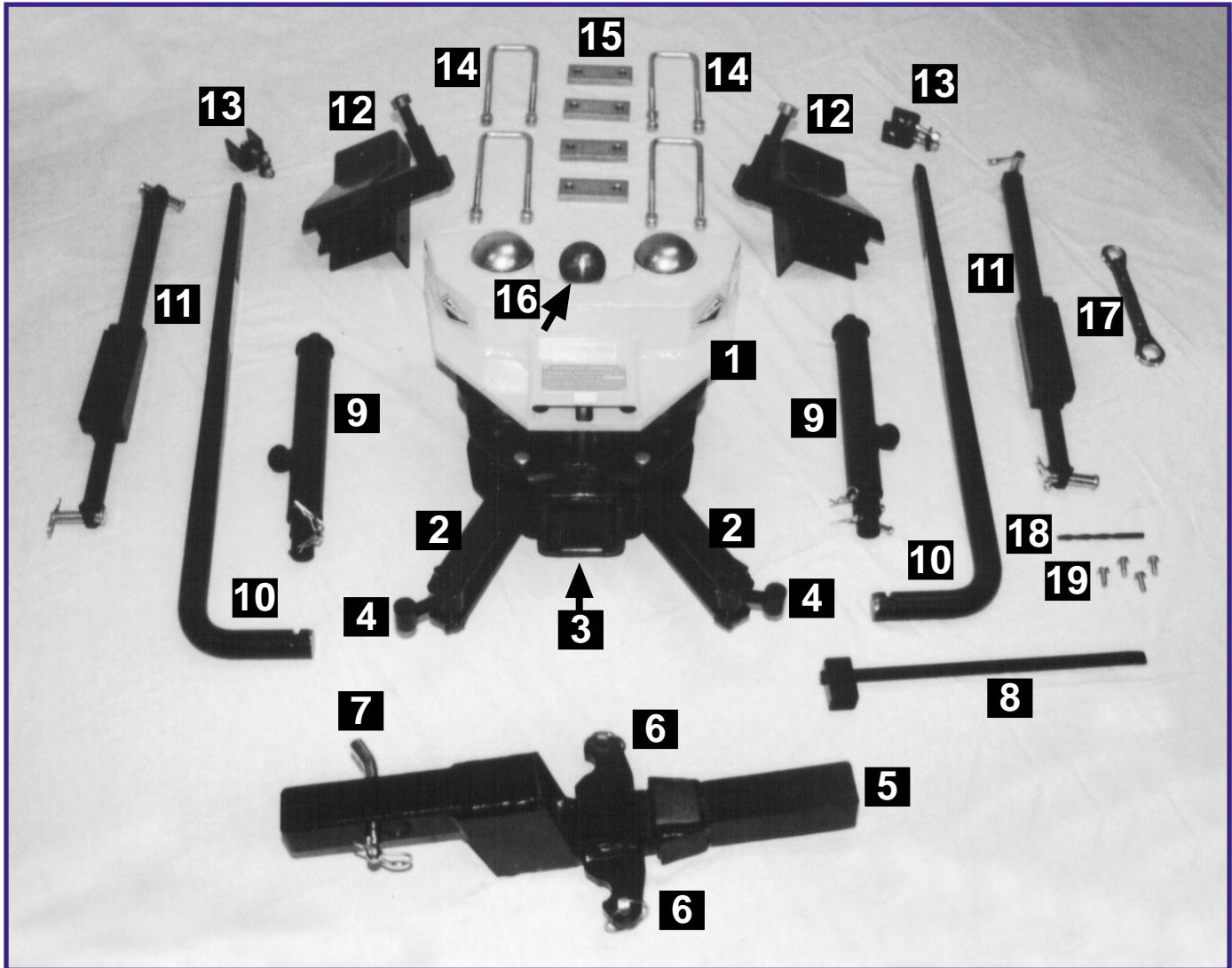

Complete normal hook-up of safety chains, electric plug, and breakaway switch cable. In some cases these will have to be lengthened due to the Hensley Arrow's extra length which increases the distance between the trailer and the tow vehicle approximately 12 inches.

INSTALLATION INSTRUCTIONS

1 Be sure the tow vehicle and trailer are on level ground and in line with each other before starting installation.

2 Insert the hitch bar into the hitch receiver of the tow vehicle. Secure the hitch bar with the hitch pin and clip.

ALWAYS Secure the hitch bar with pin and clip upon installation

3 At the front of the main hitch assembly, rotate the “Over-Center-Latch” (OCL) assemblies outward and backward toward the main hitch assembly. (see figure 1-13)

4 Lift up the main hitch assembly and slide the hitch box over the end of the hitch bar.

5 Rotate the “Over-Center-Latches” (OCL) forward over the tabs of the hitch bar. Using the “OCL” wrench on an “OCL” lug (top or bottom), rotate the adjustable screw into the notch on the hitch bar tab, and the

“OCL” links will contact the sides of the hitch box. (This is the built-in stop.)

6 Insert safety keys into the holes in the tabs on the hitch bar.

HITCH HINT:

If an “OCL” turns in with very little force, unlatch it and swing it back out. Lengthen the adjustment screw by turning the screw out, 1/2 turn at a time until it latches firmly. When properly adjusted, it takes some force (like a pair of vice-grip pliers) to get the latch firmly seated in its latched position.

If an “OCL” is too hard to turn in, do not force the latch into its latched position. Shorten the adjustment screw by turning the screw in 1/2 turn at a time until it latches firmly. When properly adjusted, it takes some force (like a pair of vice-grip pliers) to get the latch firmly seated in its latched position.

NOTE:

When properly adjusted, it will only take a small amount of force (like a pair of vice-grip pliers) to get the latch firmly seated in a locked position. It may be necessary, however, to adjust the “OCL’s” from time to time as the wedged surfaces seat themselves against each other.

* FREQUENTLY ASKED QUESTIONS CAN BE FOUND ON PAGE 35-36

INSTALLATION INSTRUCTIONS cont.

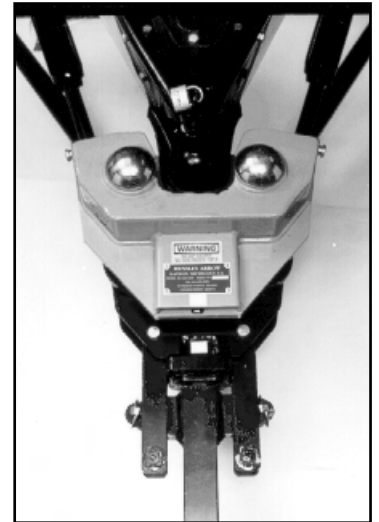
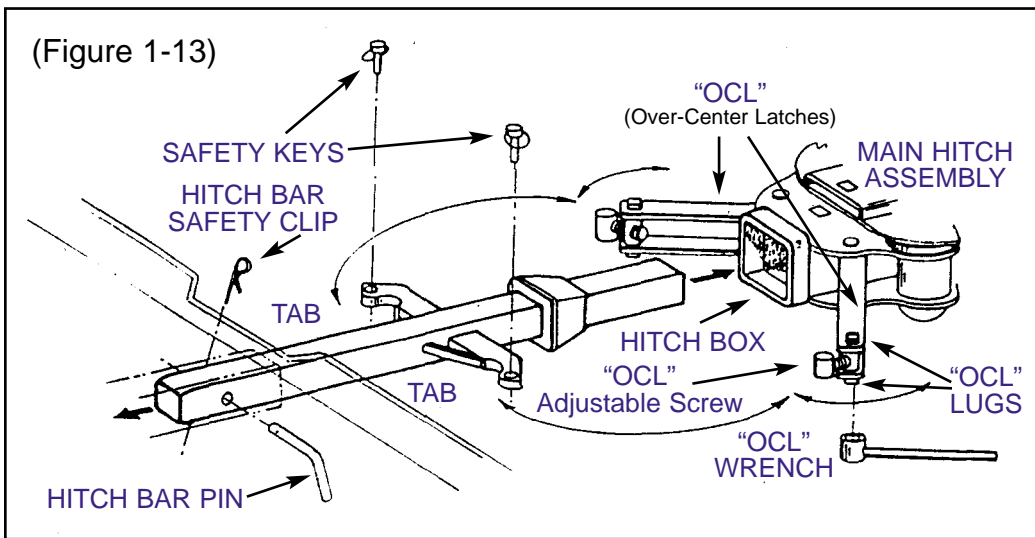

(INSTALLATION cont...)

- 7 Center the hitch assembly so that the white squares on the front (lower) and rear (upper) members are aligned. (This is for installation purposes only. White squares may be removed after installation.)
- 8 Grease the ball liberally.
- 9 Back the tow vehicle until the ball is under the coupler.
- 10 Lower coupler on to the ball and latch into place, allowing the tongue jack to continue supporting the weight of the trailer.

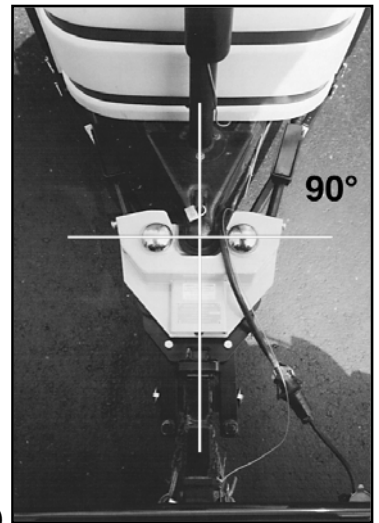

NOTE:

Some trailers equipped with the "C" type coupler (see Pg. 15, Fig. 1-19) may not latch down properly because the flange on the coupler will not allow it to fit over the ball. To accommodate for this you will need to unlatch the OCL's and slide the main unit off the hitchbar and manually lift the main unit and ball at an "angle" into the coupler. Be sure to latch the coupler lock so the main unit will not fall to the ground. The locking mechanism will support its weight. The main unit is heavy so you may need a 2nd person to do the lifting while the other locks the coupler onto the ball. You do not necessarily need to hook the vehicle back up to finish installation.

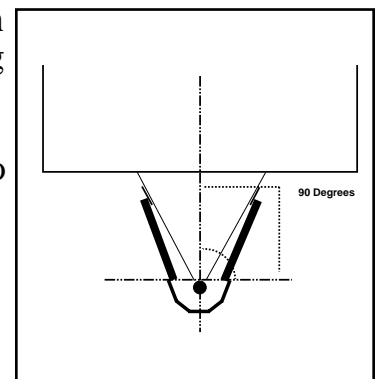

IMPORTANT:

Put the transmission in park and set the parking brake before finishing the installation.

INSTALLATION OF FRAME BRACKETS

INSTALLATION OF FRAME BRACKETS

- 1 On the trailers A-frame, measure 25 1/2" (+/- 1/2") back from the center of the ball and mark this point on the trailer A-frame.

NOTE:

This measurement should be only +/- 1/2".

- 2 Seat the frame bracket on the trailer A-frame with the front edge of the bracket at the 25 1/2" mark on the trailer frame.

NOTE:

When installed correctly, the holes of the frame bracket are forward.(see fig.# 2-15)

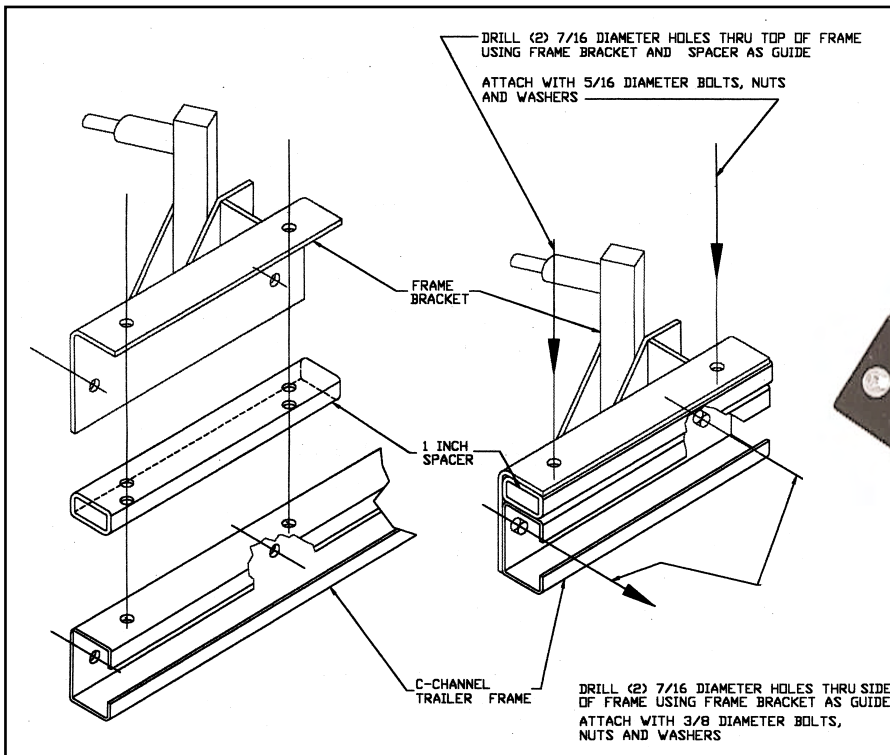
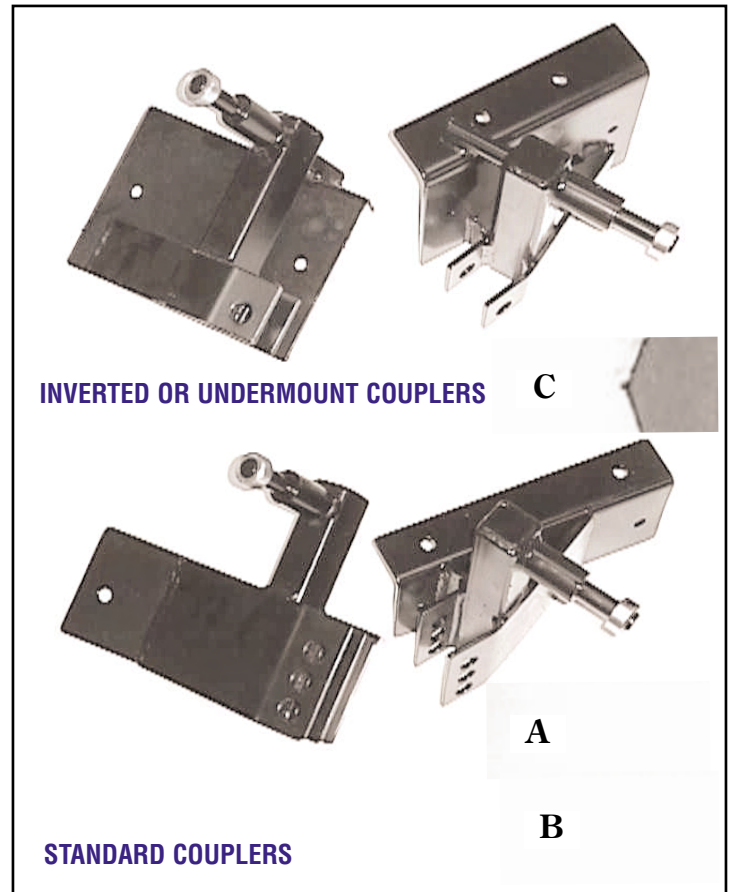

ALCO C-CHANNEL FRAME BRACKET INSTALLATION INSTRUCTIONS.

For Standard C-Channel Frames, do not use the spacers

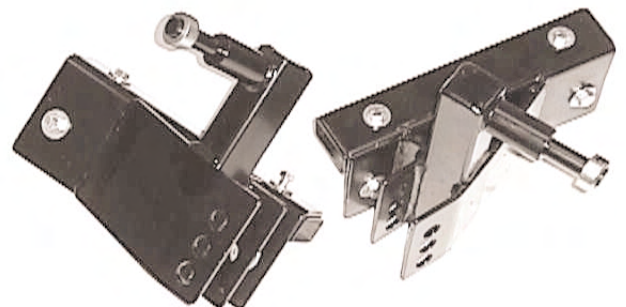

INSTALLATION OF FRAME BRACKETS cont.

3 Clamp the frame brackets to the A-frame with the U-bolts (threaded end down). Place one U-bolt on the frame bracket in front of the strut bracket spacer and one U-bolt on the rear of the frame bracket inside the angle of the strut support. (Or the closest position to these depending on the position of other attachments to the tongue.) For ALCO or Standard C-Channel Frames, refer to instructions on previous page.

4 Slide one U-bolt plate over the bottom end of each U-bolt and secure them with the lock washers and U-bolt nuts. Tighten to 45 ft. lbs.

Note: Re-torque the U-bolt nuts regularly starting within the first 200 miles.

IMPORTANT Use a torque wrench to tighten to 45 ft.lbs.

(Torque conversion chart on page 7.)

5 Using the enclosed 19/64" drill bit and any two of the four predrilled holes in the frame bracket as a guide, drill two holes in the trailer frame and install a self-tapping shear bolt into each hole. To insure proper threading, apply pressure squarely into the hole during tapping.

DO NOT OVER TIGHTEN.

Note: There are only 2 Shear bolts per bracket

6 Repeat this procedure with the other frame bracket.

FIG. 2-15

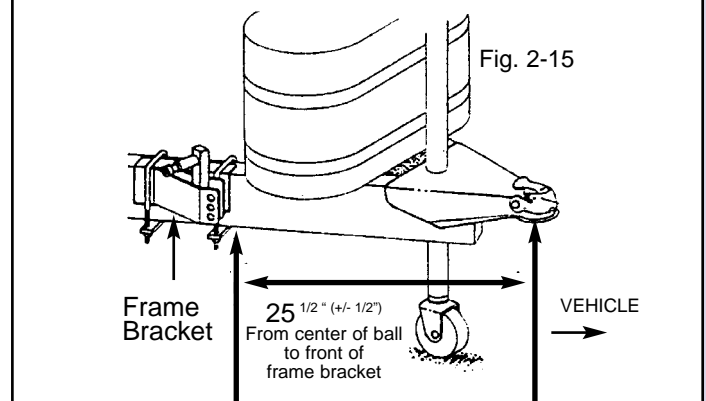

CAUTION

In some cases, damage to the struts can occur if :

- Frame brackets are not properly located 25 1/2" back from center of ball.
- U-bolts are not torqued to 45 ft. lbs. or equivalent. (See conversion chart on page 7).
- Shear bolts are not in place.

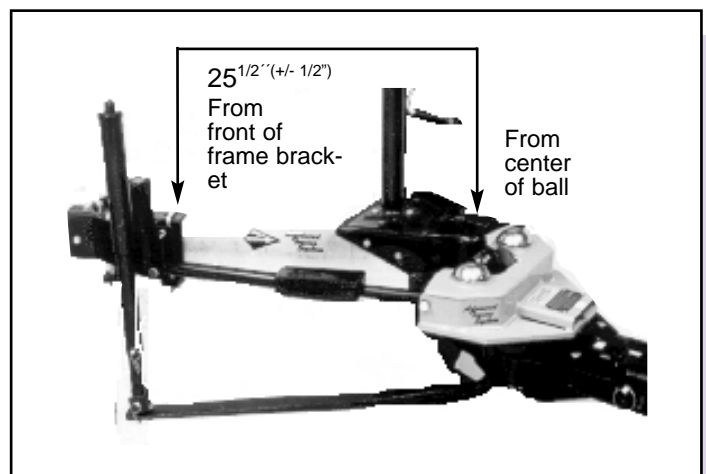

INSTALLATION OF JACKS

- 1** Remove locking collar from the mounting pin on the frame bracket and lubricate the mounting pin with grease. (Fig. 1-17)
- 2** Fully extend the jack by turning the hex nut at the top counter clockwise. If the bottom of the barrel turns with the unit, simply hold the bottom stationary and the jack will extend. Be sure to fully extend the jacks until they stop.
- 3** Mount the jack on the frame bracket by sliding it over the mounting pin as shown in the Figure 1-17. When mounted correctly, the barrel of both jacks will be on the forward side of the mounting pin (toward the tow vehicle) as Figure 2-17 shows.
- 4** Secure the jack to the mounting Bracket by replacing the locking collar and **tightening the set screw into the recess on the mounting pin** with an Allen wrench (5/32"). **The recess is normally located on the top of the mounting pin.**
Note: Check the set screw for tightness regularly.
- 5** Repeat for other side.

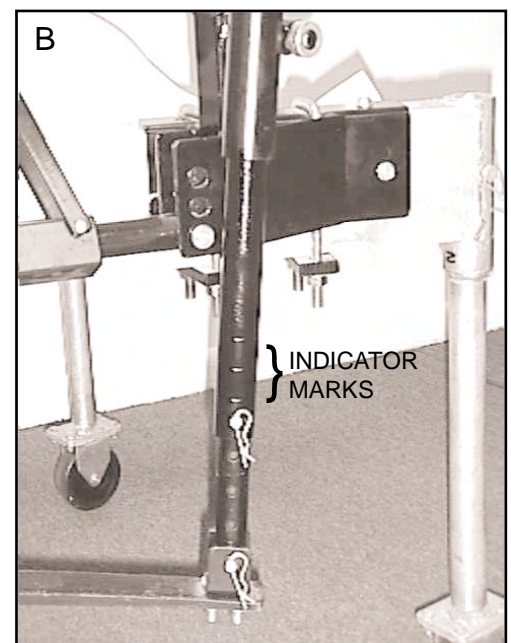
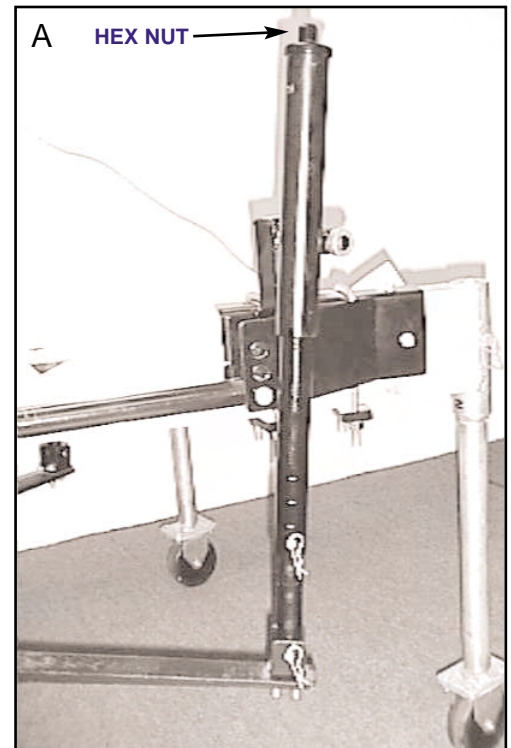

INSTALLATION OF JACKS cont.

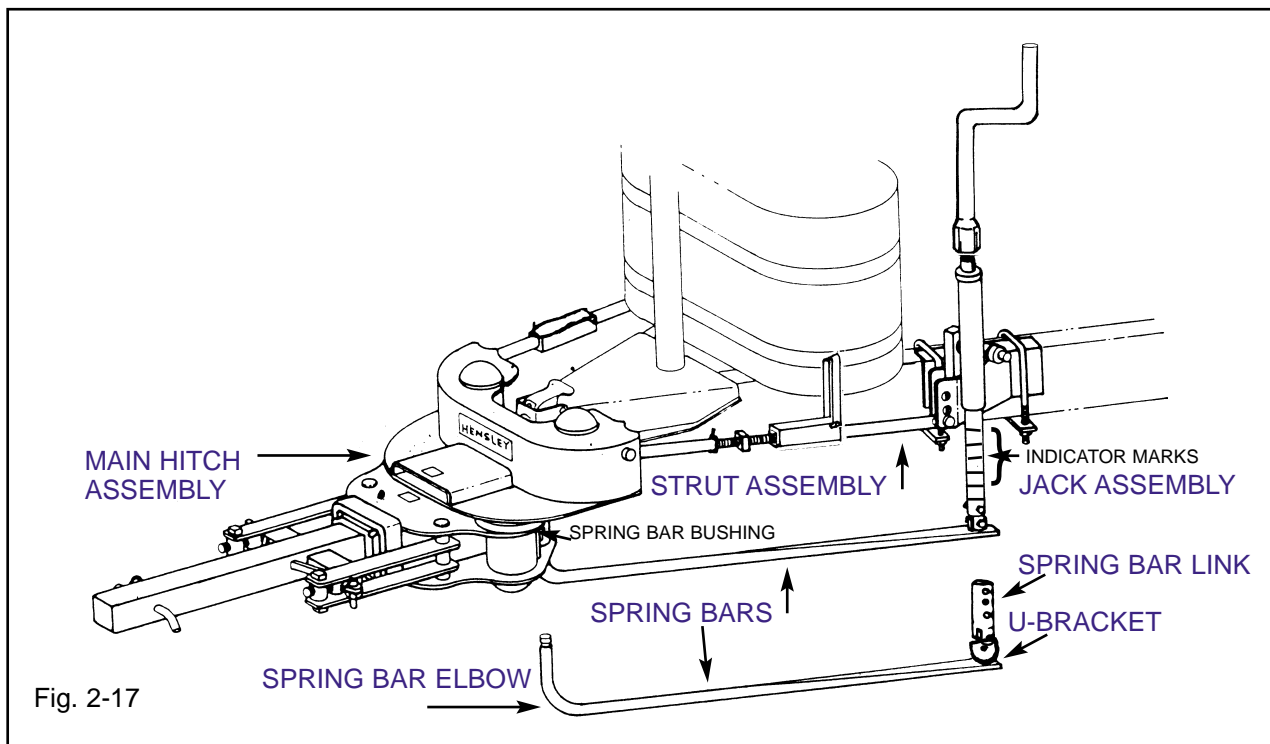
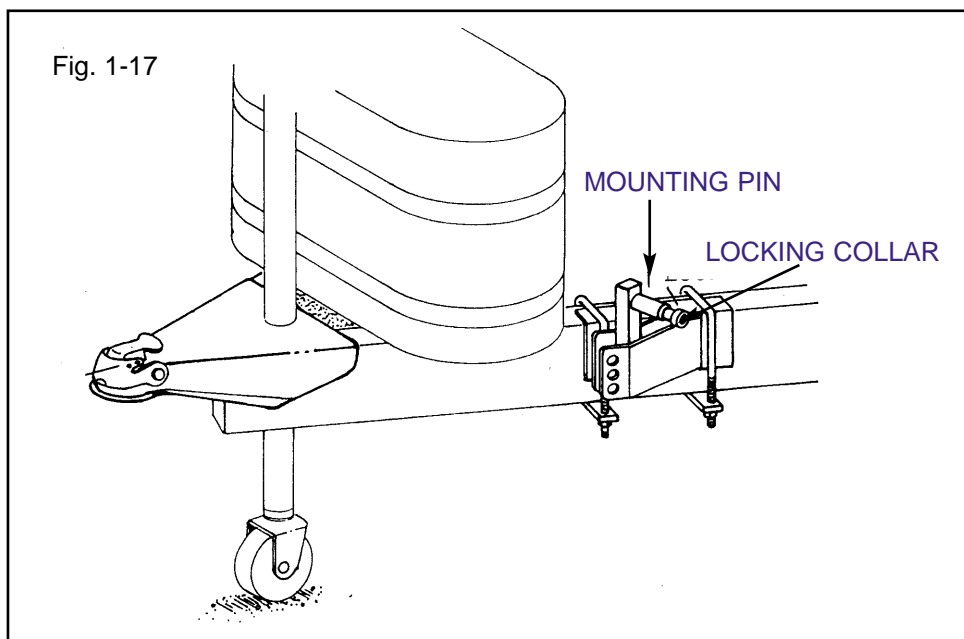

* FREQUENTLY ASKED QUESTIONS CAN BE FOUND ON PAGE 35-36

INSTALLATION OF SPRING BARS

Locate the zerk on the lower unit of the main hitch assembly (picture C). The zerk is fitted into the end of a threaded bushing which also houses a spring loaded retainer pin on the opposite side of the zerk (See Fig. 1-18). The pin should snap into the Spring Bar Groove when the bar is inserted into position in the lower unit. (Zerk fitting is preset at factory although some adjustment may be needed.) If adjustment is necessary, loosen the adjustment locknut then adjust threaded bushing into or out of lower unit as necessary to position the retainer pin correctly. Do not screw threaded bushing too far into lower unit as damage to retainer pin can occur when towing. Re-tighten locknut to secure.

Application:

Liberally grease the round end of the spring bar by hand using bearing grease from your grease gun. Avoid dropping the bar as small pebbles and dirt will stick to the grease. With the spring bar extending back toward the trailer, insert the round end of the bar into the lower unit housing and align the approximate center of the groove with the grease zerk. To lock in, exert upward pressure with one hand under the elbow of the bar while flexing the opposite end up and down. You may or may not hear the clicking sound of the retainer pin snapping into the groove. Try applying some downward pressure on the bar to see if it has locked in. If the bar falls out, you may need to adjust the retainer pin in increments of 1/2 turn at a time and retry. Do not screw the threaded bushing too far into the hole as damage can occur to the retainer pin when towing. Finally connect the lower jack pin to the spring bar U-Bracket to secure. Repeat these steps for the 2nd bar. **If your Hensley Arrow is equipped with the heavy duty 1400# spring bars and you need to disconnect the spring bars for storage or service work, to avoid damaging the retainer pin, you will need to unscrew the small zerk fitting off the threaded bushing and then rotate the spring bar forward toward the vehicle until the bar drops out of the housing. Then re-screw the zerk back onto the bushing tightly. If you have the Drawtite 750# or 1000# spring bars you do not have to unscrew the zerk. Simply disconnect the jack pin from the spring bar and rotate bar toward vehicle.**

Assembly

- 1 Grease the grooved end of the spring bar housing liberally by hand.
- 2 Insert the grooved end of the spring bar into the housing until the bar is held into position by the spring loaded retainer pin.

NOTE:

Insert the round end of the spring bar into a spring bar bushing. Grasp the elbow of the spring bar using upward pressure, while moving the opposite end of the spring bar up and down until the spring bar snaps into place.

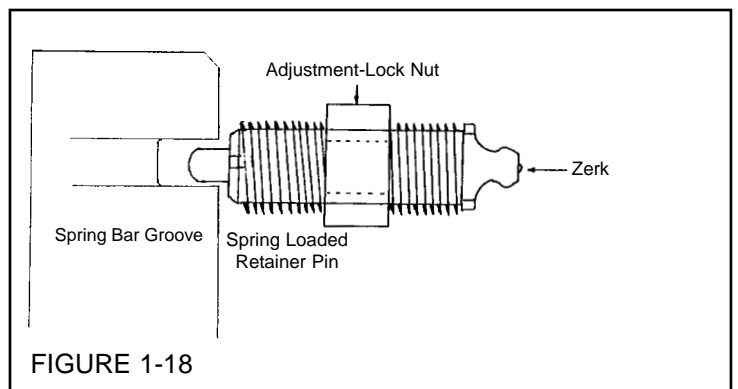
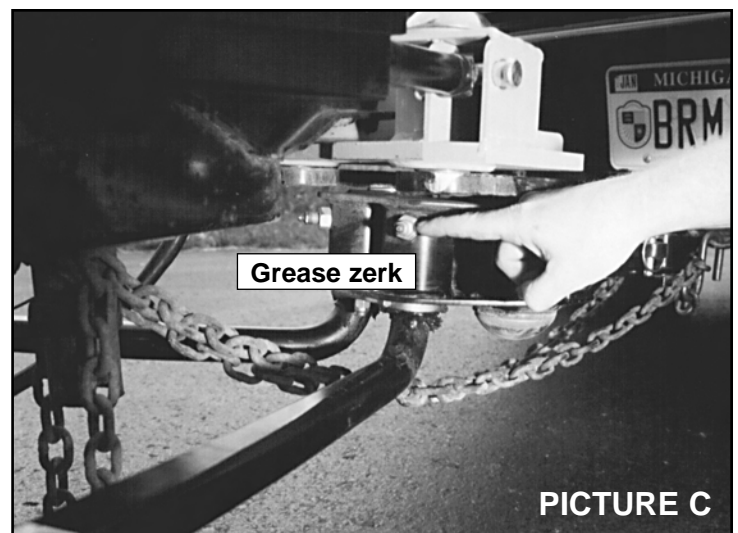

INSTALLATION OF SPRING BARS cont.

- 3 Attach the end of the spring bar to the bottom of the jacks.
 - A. Turn the bottom of the Jack so that the three height indicator marks are facing out and visible.
 - B. Attach the spring bar to the bottom of the jack using the pins and clips provided. Insert the pin from the back side, and pin from the front by pushing it all the way through to the round portion of the pin.
- 4 Set the spring bar links using the coupler style chart as a starting point. (Example: If you have coupler style A, put the pin in the fifth hole up from the bottom of the link. The first hole is used to attach the link to the spring bar, there will be three empty holes and the link will be pinned in the fifth hole.) If this setting will not allow your jacks to be adjusted such that they will hold the hitch head horizontal with the ground, the spring bar links can be adjusted as needed. (See 1-19 for starting position suggestions)
- 5 Repeat this procedure with the other spring bar.
- 6 Using Grease Gun, apply grease thru the grease zerks until you see it come out the bottom of housing.

SUGGESTED STARTING POSITIONS

(Can vary with different vehicle/trailer combinations)

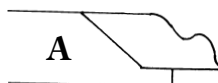

If you have coupler A you'll have 3 holes showing on the spring bar link.

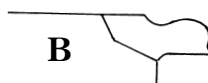

If you have coupler B you'll have 2 holes showing on the spring bar link.

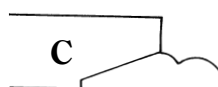

If you have coupler C you'll have 3 holes showing on the spring bar link.

Fig.1-19

HITCH HINT:

On the jack barrel, be sure the three height indicator marks are facing away from the trailer A-frame for future reference. (Fig. 2-19)

Fig. 2-19

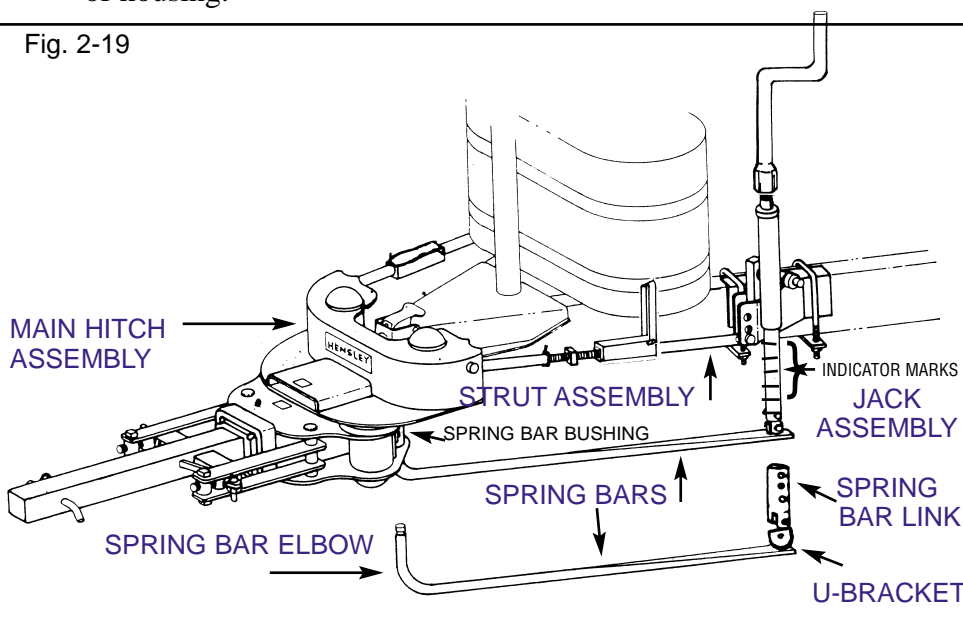

IMPORTANT: Be sure both the spring bar links are installed at the same height (i.e. same number of holes are showing on both sides.)

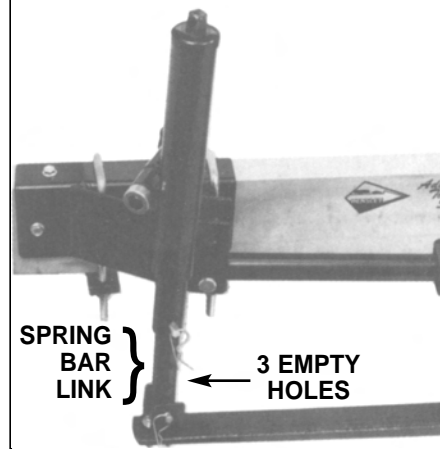

Fig. 3-19

INSTALLATION OF STRUT ASSEMBLIES

IMPORTANT FOR PROPER HITCH PERFORMANCE

The struts are one of the most important components of the Hensley Arrow. Failing to install or adjust them properly may impede the systems performance. Please read the instructions carefully.

1 Raise the handle and slide the locking sleeve back to reveal the square strut nut. Adjust the nut toward the locking sleeve post as far as the threading will allow.

2 Secure the strut between the main hitch assembly and the frame bracket using the 5/8" x 2 1/2" pins and clips provided. When properly installed, the locking sleeve post will be closer to the main hitch assembly and will be in the up position as shown in the diagram. (2-21)

Repeat steps with the other strut assembly.

3 **Field Notes:** (a) If your frame bracket has more than one hole available, select the one which positions the strut closest to parallel with the top of the trailer A-frame.

(b) The 5/8" x 2 1/2" pins should be inserted from the outside-in so that the retaining clip is inserted on the back side, closest to the A-frame. Push the retaining clip all the way through to the round portion. You may elect to replace the retainer clips provided with more permanent cotter keys (not provided) after you are certain all the components have been inserted and adjusted correctly. (See figure A. pg. 12).

(c) If the handle of the locking sleeve does not reach far enough to fit down over the locking sleeve post when the sleeve has been advanced into position, the handle may need to be turned back in the other direction. Observe the position of the rivet in the diagram.

The struts are now installed but not adjusted. Disconnect vehicle from Hensley Arrow™ and adjust struts. (Continue to page 17 to complete strut adjustments.)

NOTE:
Level struts are important for proper handling.

IMPORTANT

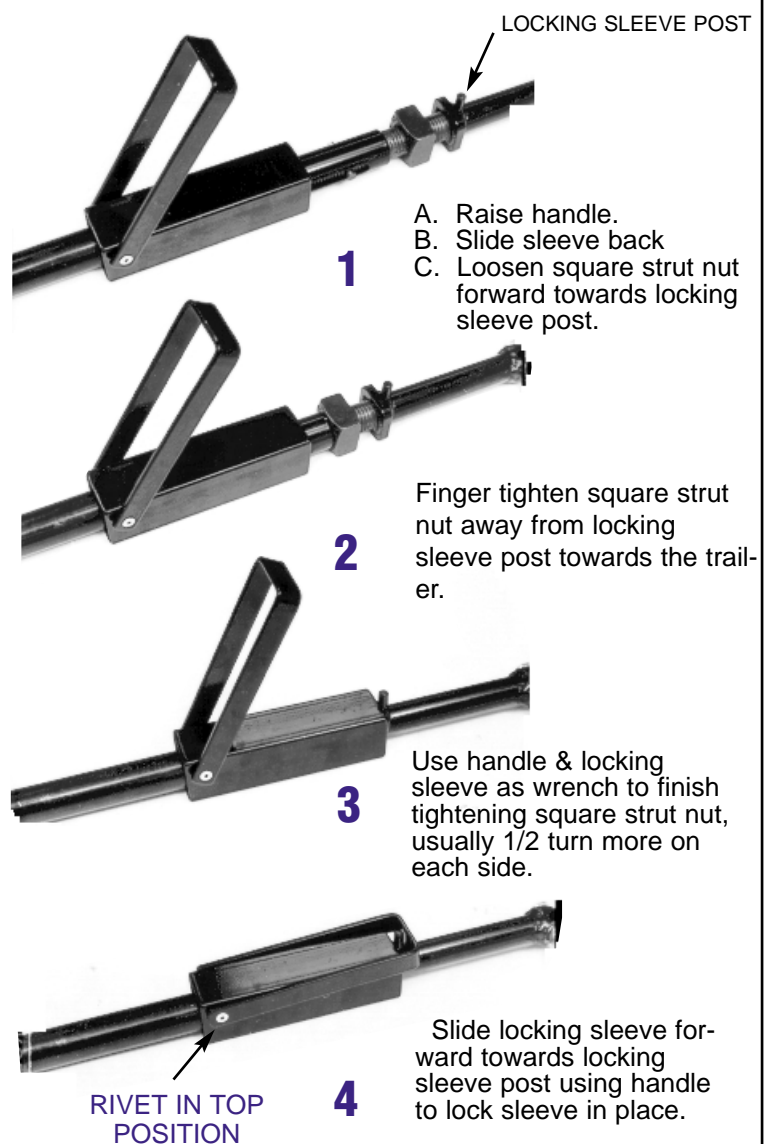

HENSLEY ARROW STRUT ADJUSTMENT

IMPORTANT FOR PROPER HITCH PERFORMANCE

The major function of the struts is to hold the Upper Unit (the orange section with the ball mount on it) “square” in relationship to the trailer. **When both struts are tight, they will not allow either the Upper Unit or the trailer to pivot from side to side on the ball.** (Struts will not move when shaken. They should feel like a solid bar.) Be sure to check them at each hookup. Refer to steps 1-4 on opposite page.

The struts are correctly adjusted when the Upper Unit is held firmly in a position perpendicular to the centerline of the trailer as shown. It doesn't have to be absolutely perfect! (For all you perfectionist types.) You can take measurements if you want, but most people will be able to line it up sufficiently just by looking at the unit in relationship to the A-frame. Strut adjustment is not difficult or mysterious. Make sure the Upper Unit is in this position, the struts are tight. You should check for tightness every time you hookup.

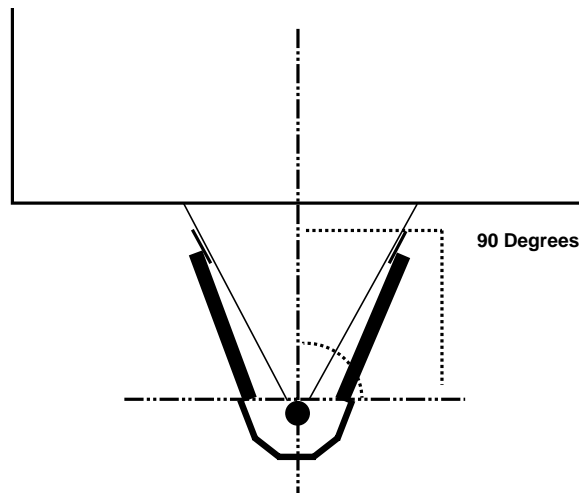

Note: The length of the strut will depend on placement of the Frame Bracket. For example, if the right bracket is 1/2" further back on the A-frame than the left bracket, the right strut will be longer than the left one in order to hold the Upper Unit “square” with the trailer. Also, many other factors could account for “long and short” struts.

STRUT ASSEMBLY

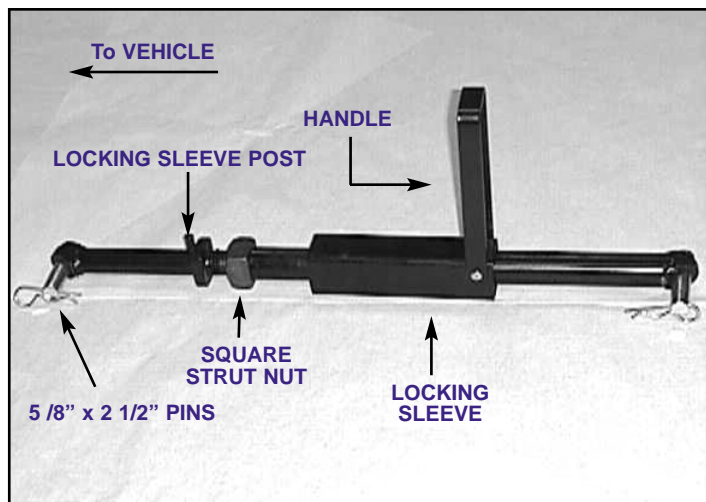

FIG. 1-21

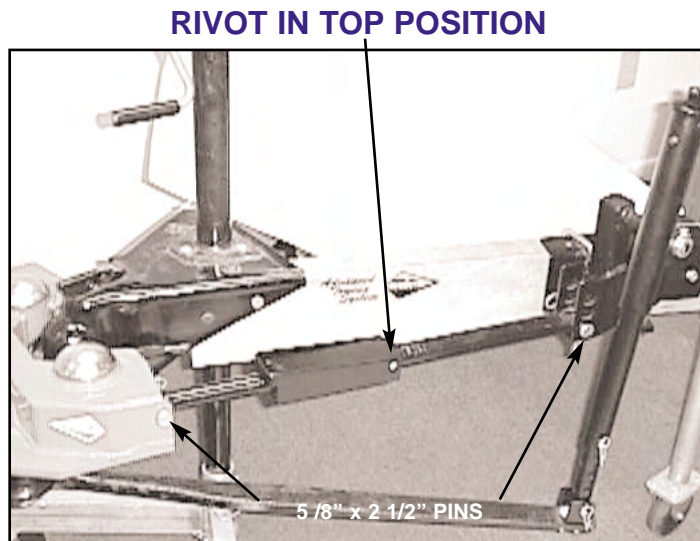

FIG. 2-21

TENSIONING SPRING BARS

The amount of tension adjustment on the spring bars varies with the trailer/vehicle combination, load distribution within the trailer and whether you prefer a stiff or soft ride.

Your vehicle and travel trailer may not be perfectly level, even with the Hensley Arrow™ weight distributing qualities. This is due to differences in the trailer/vehicle combinations and load distribution within the trailer.

The height indicator marks on the outside of the jack barrel are designed as a gauge. Start by adjusting to the same height indicator mark on the outside of the jack barrel at the start of each trip. This is just a starting point. We recommend to put them on the middle mark to begin.

Adjustments to the jack tensioning system can be made at any time during your travels.

If the ride feels too soft or too stiff, the spring bars can be tensioned or untensioned to make your ride more comfortable.

Tensioning the spring bars can be done by using the ratchet wrench (provided), BAL hand crank, socket ratchet or drill with socket.

* SPRING BARS CAN HANDLE THE MAXIMUM TENSION THAT THE JACKS WILL ALLOW

 Turn to the *right* to raise the spring bar which *adds* tension, and stiffens the ride.

 Turn to the *left* to lower the spring bar, which releases tension, and softens the ride.

WARNING

EXCEEDING MAXIMUM CAPACITY CREATES A SAFETY HAZARD

The Hensley Arrow™ system attaches to the trailer tongue. It is rated for a maximum tongue weight of 1,400 lbs and gross weight of the trailer of 14,000 lbs. (including the load).

The towing vehicle, and the vehicle hitch receiver, that is the connecting mechanism that includes the ball platform and other components that extend and attach to the towing vehicle, are both separately rated for maximum tongue weight and gross weight of the trailer (including the load).

Refer to the manufacturer of your vehicle and your vehicle hitch receiver for the maximum tongue weight and gross weight of your towing vehicle and vehicle hitch receiver.

Do not exceed the maximum of your towing vehicle, your vehicle hitch receiver or the Hensley Arrow™ towing system.

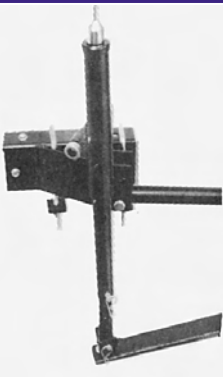

Tension the spring bars by using the wrench.

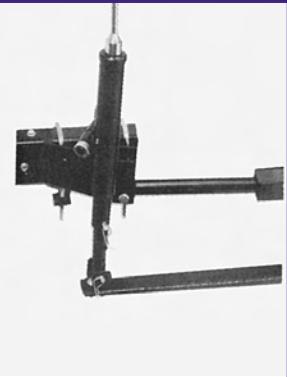

IMPORTANT

The jack **MUST** have at least 2 holes open.

DO NOT pin the Spring bar link with only one hole open.
(See Fig. 1-19)

Turn the wrench to the *right* to raise the spring bar which *adds* tension.

Turn the wrench to the *left* to lower the spring bar, which *releases* tension.

IMPORTANT

The jack **MUST** have at least 2 holes open.

DO NOT pin the Spring bar link with only one hole open.
(See Fig. 1-19)

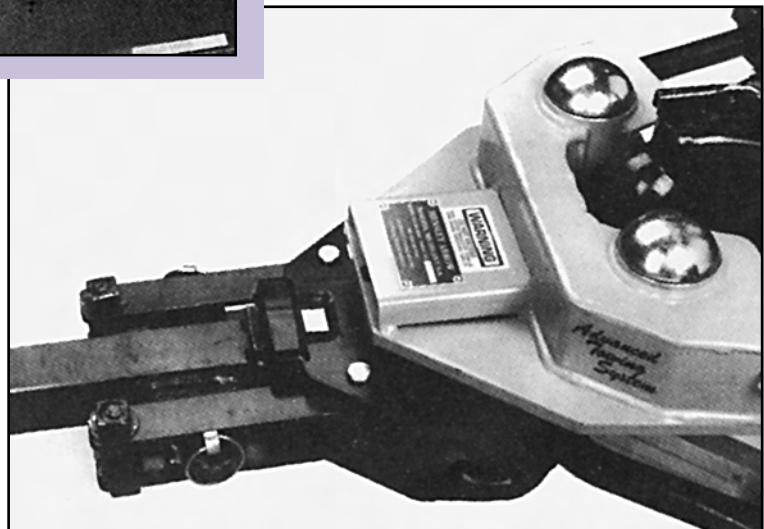
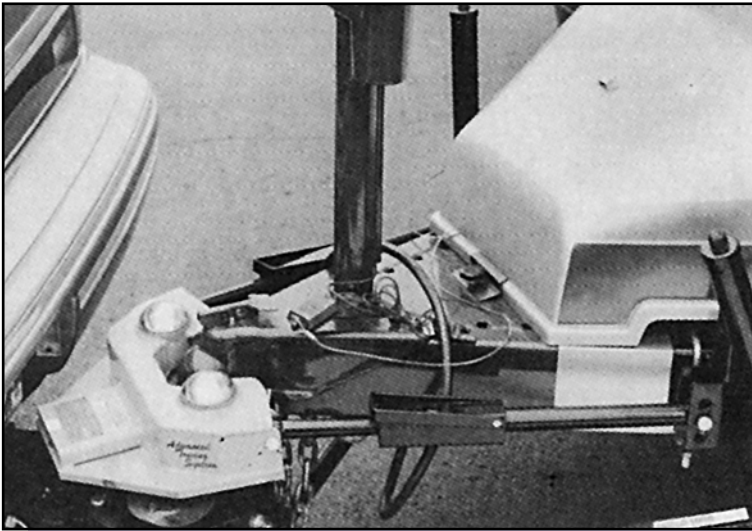

TENSIONING SPRING BARS cont.

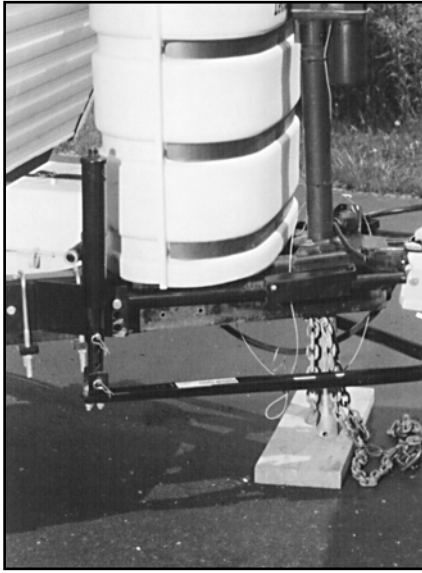

Tension the spring bars by using the ratchet wrench.

Turn the ratchet wrench *clockwise* to raise the spring bar, which *adds* tension.

Turn the ratchet wrench *counter clockwise* to lower the spring bar, which *releases* tension.

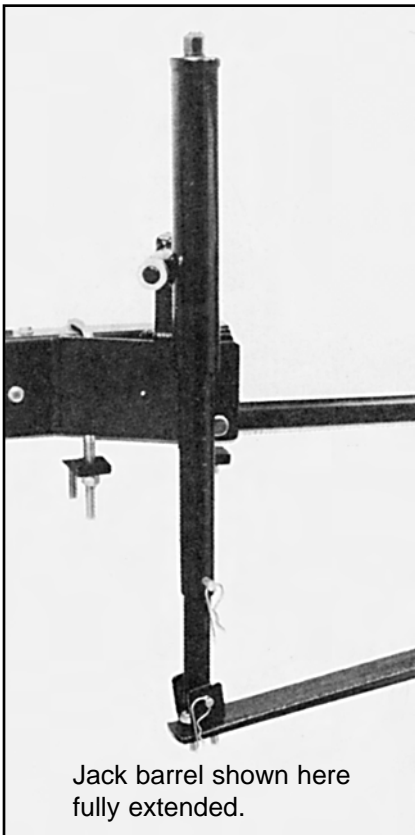
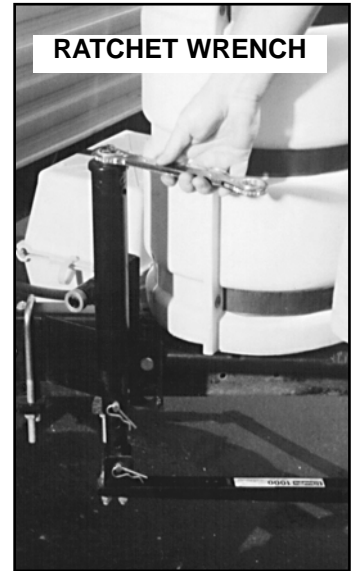

Jack barrel shown here fully extended.

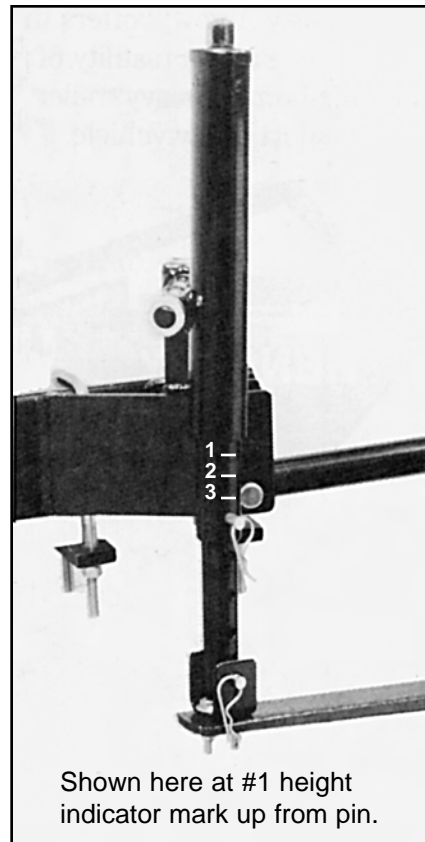

Shown here at #1 height indicator mark up from pin.

HOOK-UP PROCEDURE

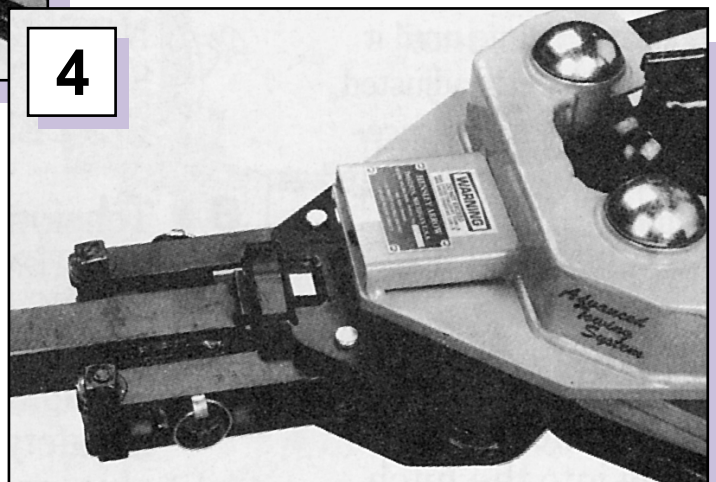

HOOK-UP PROCEDURES

Be sure the trailer wheels are chocked.



- 1 Insert the hitch bar into the 2" square hitch receiver on the tow vehicle. Secure the hitch bar with the pin and clip.

(NEVER insert the hitch bar without immediately pinning it in place.)

- 2 With the hitch bar pinned in the tow vehicle, back toward the travel trailer as if you were going to make an attempt to hook-up. Stop about 18" from the hitch box.

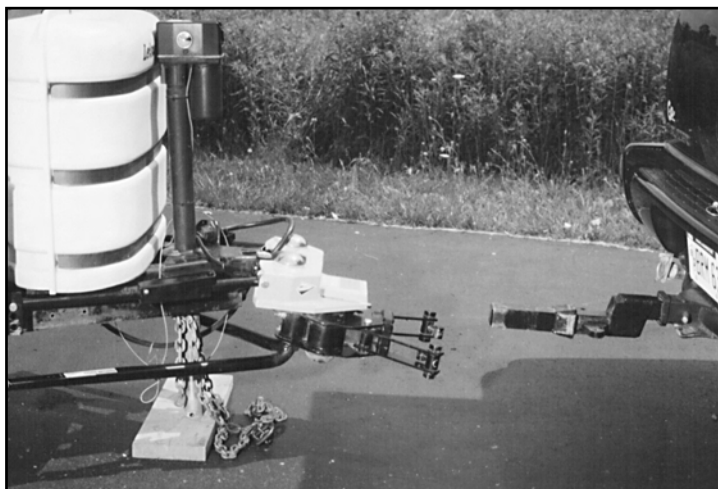

HOOK-UP PROCEDURES cont.

- 3** After placing your vehicle in park, observe the angle at which the hitch bar is sticking out from the tow vehicle.



- 4** After you have observed this angle, remove the hitch bar from the vehicle and place it into the hitch box on the travel trailer.

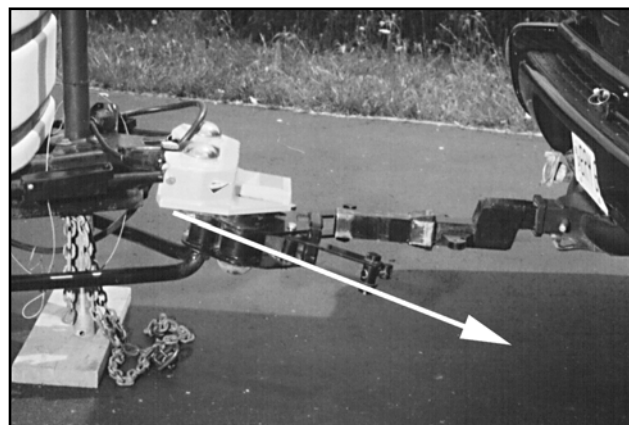
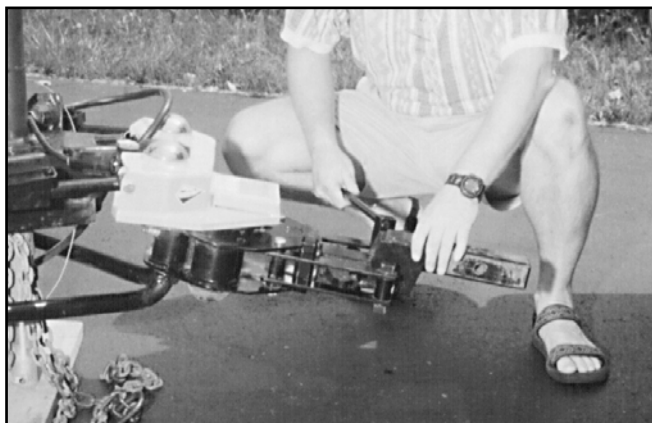
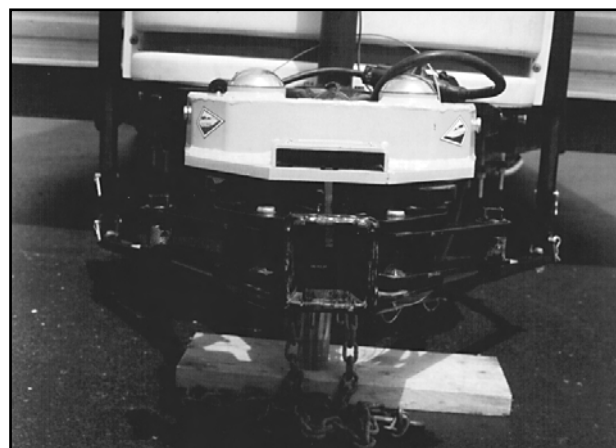
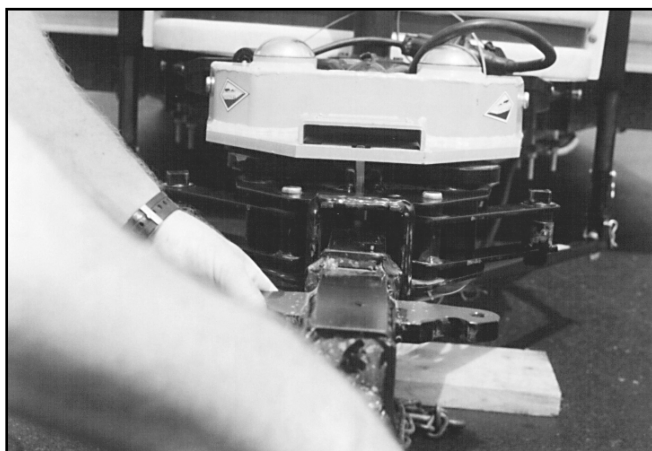

Secure it with (1) OCL.

Observe that angle.

HOOK-UP PROCEDURES cont.

- 5** The goal is to have both angles matching or mirroring each other. Remembering the angle sticking out of the tow vehicle, maneuver the angle of the hitch box by tensioning or untensioning the spring bars with the spring bar jacks. (This is like maneuvering a wheelbarrow. Your arms are the jacks and the wheelbarrow handles are the spring bars.)

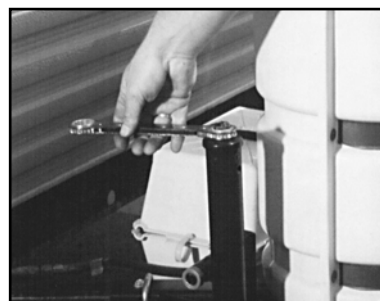
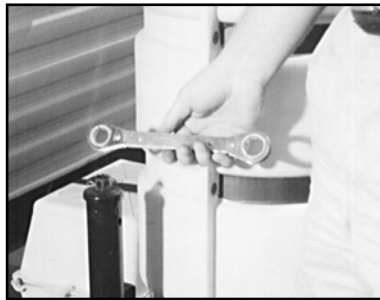

- 6** Once you see the hitch box angle matches the angle from the tow vehicle, remove the hitch bar from the hitch box on the travel trailer and replace it in the tow vehicle pinning securely into place.



IMPORTANT:

Put the transmission in park and set the parking brake so the tow vehicle will not roll and pull the hitch bar partially out of the hitch box.

IMPORTANT:

Be sure the tow vehicle wheels are straight ahead when backing the hitch bar into the hitch box and when pulling out of the hitch box with the tow vehicle.

HOOK-UP PROCEDURES cont..

HITCH HINT:

If an “OCL” locks in with very little force, unlatch it and swing it back out. Lengthen the adjustment screw by turning the screw out, 1/2 turn at a time until it latches firmly. When properly adjusted, it takes some force (like a pair of vice-grip pliers) to get the latch firmly seated in its latched position.



If an “OCL” is too hard to lock in, do not force the latch into its latched position. Shorten the adjustment screw by turning the screw in 1/2 turn at a time until it latches firmly. When properly adjusted, it takes some force (like a pair of vice-grip pliers) to get the latch firmly seated in its latched position.



8

Finish the connection by camming the hitch bar securely into place with the “OCLs.” Install the safety keys, connect the safety cable, safety chains, and electrical cord.



CAUTION:
**(DO NOT TOW WITH-
OUT SAFETY KEYS IN
PLACE!)**



IMPORTANT:

The routing for safety chains is between and under the spring bars.

7

Back up toward the travel trailer again. This time stop 3-4 inches from the hitch box and adjust the height of the hitch box opening by moving the travel trailer tongue jack up or down. Center the hitch bar in the opening. Back the hitch bar into the hitch box. Don't be afraid to be somewhat aggressive.

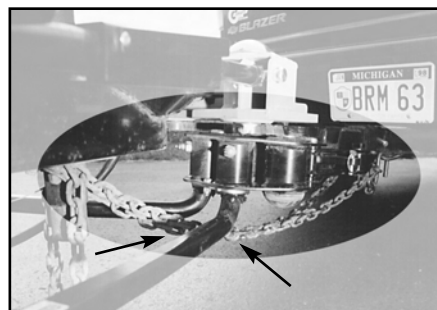
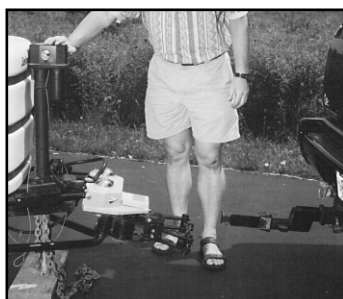

Between and under spring bars.

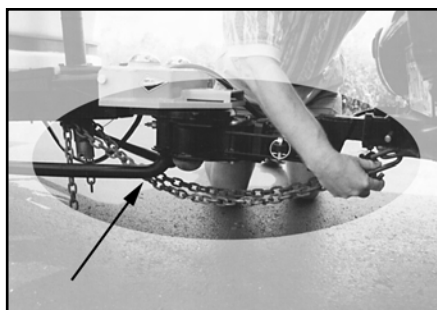

HOOK-UP PROCEDURES cont..

9

Engage weight distribution to your towing position by tensioning the spring bars using the spring bar jacks. Also use the height indicator marks on the jacks making sure both sides are equal height for towing. Usually 3rd height indicator mark or less.

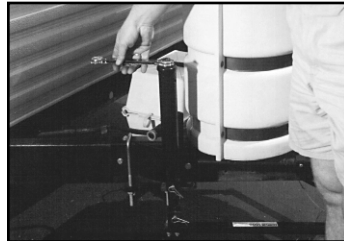
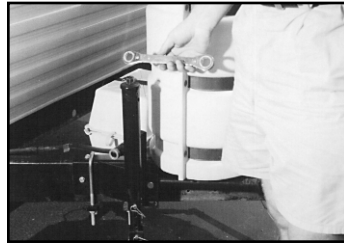

10

Raise the tongue jack of the travel trailer completely up and out of the way. Put away tools and unchock wheels.



IMPORTANT:

Before you tow, pull forward and make sharp turns both ways to be sure everything works freely. Especially check the break-away cable and electric cord to be sure they don't bind or get pinched. In most cases, the best routing for the break-away cable, and electric cord is over the top of the main unit since the Hensley Arrow™ doesn't allow the coupler to turn on the ball.

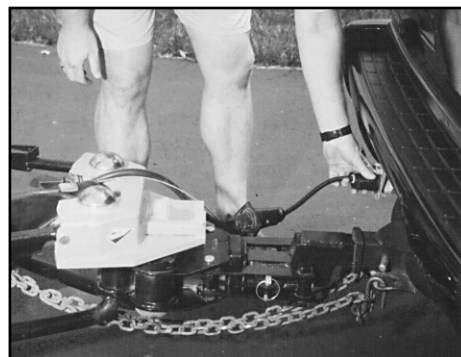
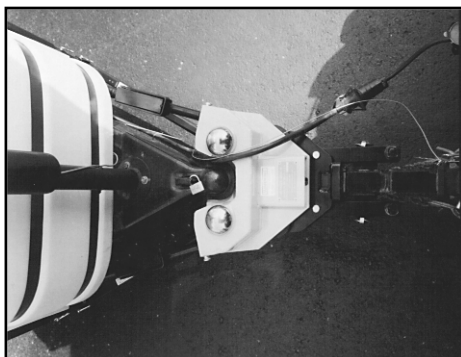

Complete normal hook-up of safety chains, electric plug, and break-away switch cable. In some cases these will have to be lengthened due to the Hensley Arrow's extra length which increases the distance between the trailer and the tow vehicle approximately 12 inches.

UNHOOKING PROCEDURES

- 1** Chock travel trailer tires.



- 2** Put the travel trailer tongue jack down, raising the travel trailer enough to take the tongue weight of the trailer off the tow vehicle. (This can be measured prior to hooking up or could be the measurement given when the hitch was ordered - measurement from the ground to the top inside of 2" receiver on vehicle - trailer not hooked up and vehicle running).

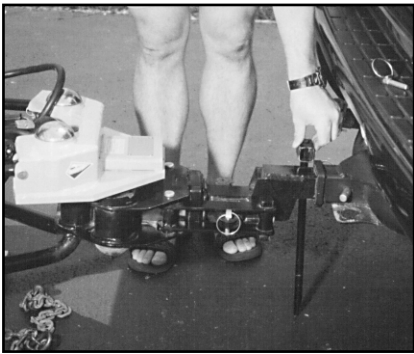

- 3** Start un-tensioning the spring bars using the spring bar jacks and the supplied ratchet wrench. As you un-tension them, you will start to see the spring bar become "sloppy loose." Continue un-tensioning the jacks until either they stop or until they start to tighten again (this is called reverse tension). This process will take into account any angles between your vehicle and the travel trailer (side to side/front to back).



- 4** Disconnect electrical cord, safety cable and safety chains. Remove safety keys and open "OCLs."

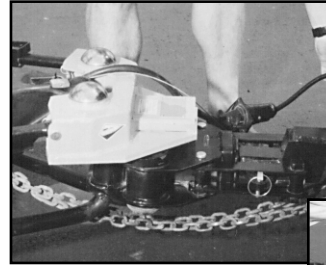

- 5** Pull away from travel trailer.

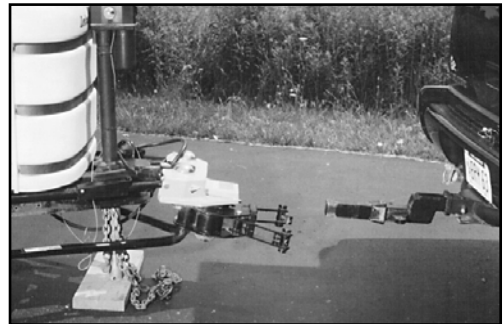

Level for sleeping and refrigeration.



MORE HITCH HINTS

Since not all campgrounds have pull-through lots and sites are unlevel, this section will give you tips on dealing with the phenomenon of hooking and unhooking at unusual angles.

The following little exercise will help you better understand hooking and unhooking with the Hensley Arrow and why we compare the jacks like two arms and the spring bars like wheelbarrow handles.

- ☞ Do this procedure without the vehicle by putting the hitch bar in the hitch box and fastening the “OCL” on each side. (Not hooked up to tow vehicle)
- ☞ Fully extend jacks.
- ☞ Tension one side all the way up watching the angle changes of the hitch bar.
- ☞ Tension the other side all the way up noting further angle changes.

This will give you an idea of how the jack/spring bar combination will hold the hitch head at the **SAME** angle you unhooked from.

WE APPRECIATE YOUR BRIGHT IDEAS!

If you discover an easier or helpful method for installing the Hensley Arrow™ or have a suggestion for improvements, please call us at:

1-800-410-6580

or write to us:

Hensley Mfg., Inc.

1097 S. State Road • Davison, MI 48423

e-mail: info@hensleymfg.com

internet: www.hensleymfg.com

MAINTENANCE

Spring bars should be greased before an extended trip and at 500 mile intervals.
(Cannot be over greased)

- There are two options for greasing the spring bars.

1 Use a grease gun on the grease zerks provided. (Recommended) Fill them until you see grease come out of the bottom of the housing. **Note:** Squeaking or groaning around turns usually means the bars could use more grease.

2 Remove the spring bars and apply grease directly to the round end of the spring bars and spring bar bushing. Use caution to keep dirt off the grease portion of the spring bar. (Greasing the bars by hand should be done during initial installation as well.)

☞ To remove the spring bar, remove the pin from the spring bar U-bracket and jack assembly at the rear of the spring bar. If your Hensley Arrow came equipped with the heavy duty 1400# spring bars, you will need to unscrew the zerk fitting off the threaded bushing first and then rotate the bar around toward the vehicle until it drops out of the housing. Then replace zerk back onto bushing tightly. If equipped with the Drawtite bars you do not need to remove the zerk. Simply rotate bar until it drops out. **Note:** The Drawtite bars are denoted by a sticker, the heavy duty bars are not.

☞ To reinstall spring bars, insert the round end of the spring bar into the bushing and align the center of the groove with the zerk fitting. Apply upward pressure until the bar locks in place. If the bar falls out with downward pressure, you may need to adjust the retainer pin 1/2 turn at a time and repeat the process.

It is still a good idea after greasing the bars by hand to finish filling the housing using a grease gun on the zerks themselves.

- Grease spring bars every 500 miles (Can't over grease)
- Check the U-Bolts which clamp the frame brackets to the trailers A-frame within the first 200 miles after installation and every 5000 miles thereafter. TORQUE THESE NUTS TO 45 ft. lbs.
- It is very important to check that the strut bars are tight and will not move when gripped and shaken. If loose tighten square nut. Check these at every hookup, on a level, flat surface.
- Periodic greasing of the hitch ball and coupler will prolong the life of these parts.
- A light coating of oil or grease on the wedges of the hitch bar will make latching and removal of the hitch bar easier.
- Periodic paint touch up is recommended for the Hensley Arrow hitch on a regular basis. You may find a close match on paint colors at any hardware store.
Note: Hensley Mfg., Inc. cannot supply touch up paint.

INSPECTION

- ☞ Check the U-bolts which clamp the frame brackets to the trailers A-frame within the first 200 miles after installation and every 5,000 miles thereafter. Torque these nuts to 45 ft. lbs.
- ☞ Check for proper strut adjustment at each hookup. (ARE THEY TIGHT)?
- ☞ Check the nuts that attach the spring bar U-brackets to the spring bars. Torque these nuts to 30 ft. lbs.
- ☞ Check to see that all pins and clips are in place with the clips pushed through to the rounded position.
- ☞ Inspect the complete unit for any unusual wear or damage.

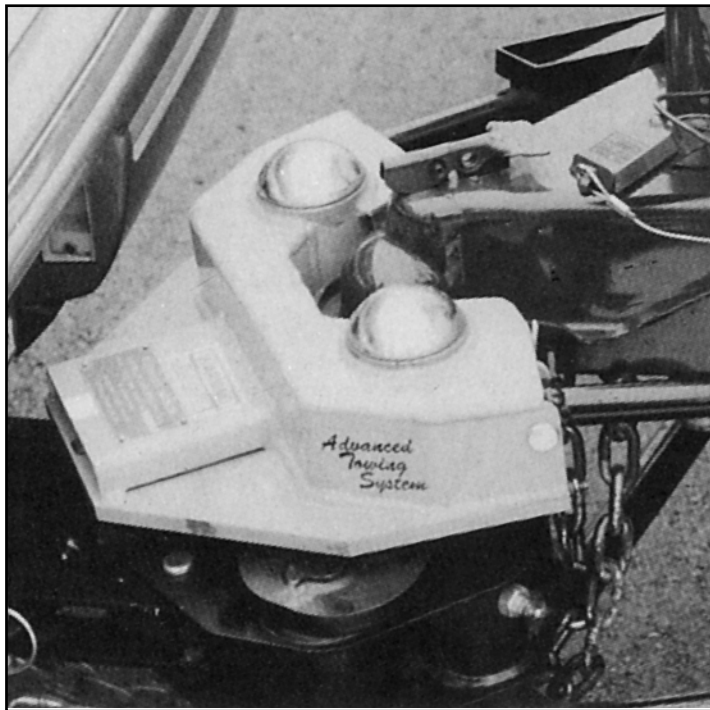

WARNING
DO NOT EXCEED
MAXIMUM GROSS
TRAILER WEIGHT
14,000 LBS
MAXIMUM GROSS
TONGUE WEIGHT
1,400 LBS

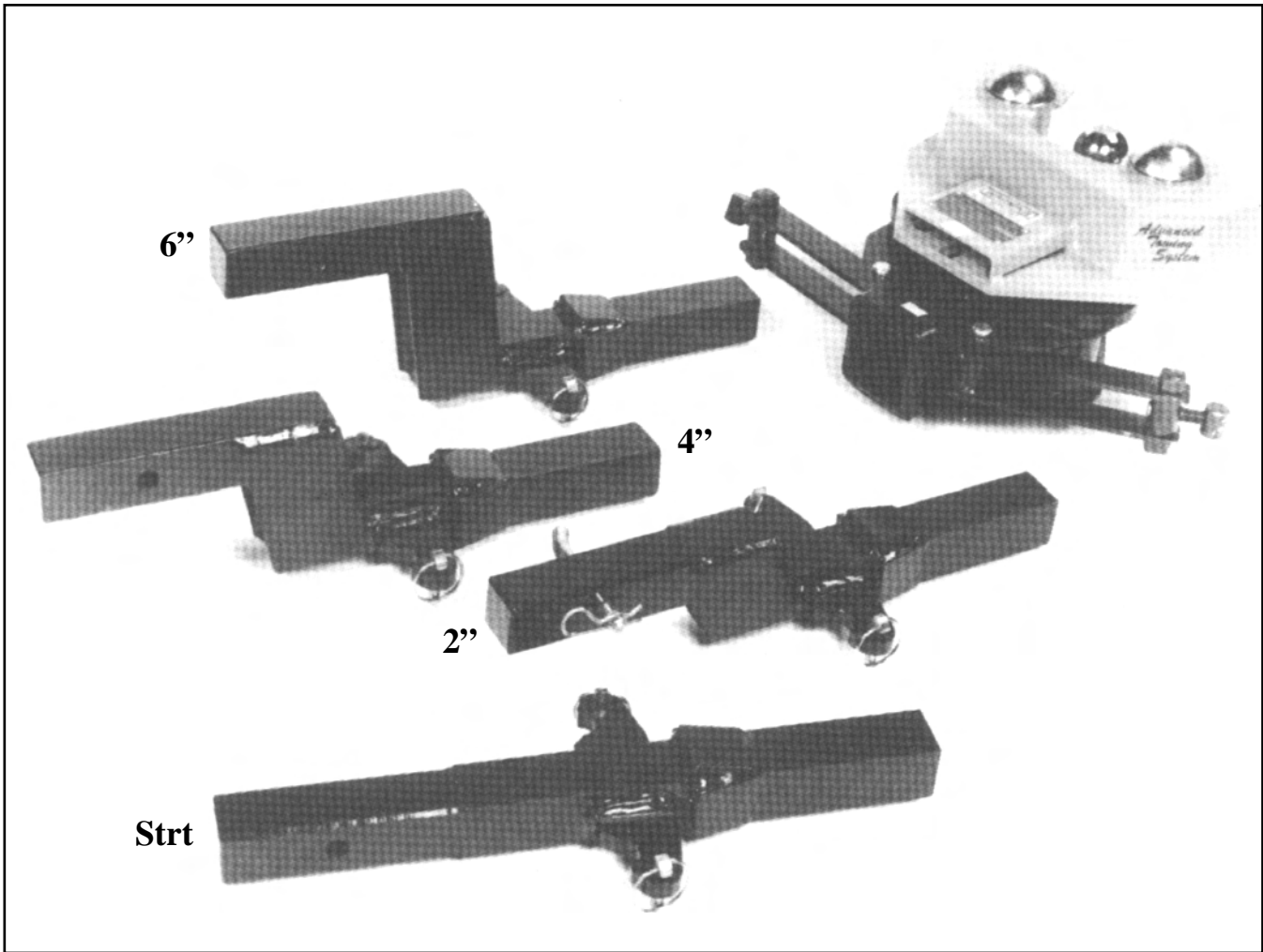

**Also available in an 8" offset. Not Shown!*

HENSLEY ARROW EXCHANGE CLUB

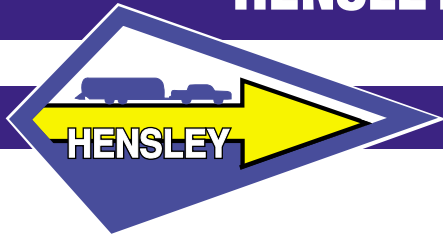

The Hensley Arrow™ Exchange Club is available to all original owners of the Hensley Arrow™ towing system.

It allows you, the original owner, to exchange your hitch bar for a small shipping and handling fee.

We will charge \$175.00 plus shipping and handling for your new bar and issue a return number for the old bar.

To complete the exchange, return your old hitch bar to the address below and we will refund the cost of the hitch bar.

You must have a return number to receive any refunds. An orange piece of paper will be mailed to you to return with the part.

It is important to clearly mark your name and address inside the box that you return.

FOR HITCH BAR EXCHANGE AND WARRANTY RETURNS

SHIP TO:
HENSLEY MFG., INC.
151 Shafer Drive
Romeo, MI 48065

HENSLEY ARROW TOWING SYSTEM HOOKING-UP

1. With the hitch bar pinned in the tow vehicle, back toward the travel trailer as if you were going to make an attempt to hook-up. Stop about 18” from the hitch box.
2. After placing your vehicle in park, observe the angle at which the hitch bar is sticking out from the tow vehicle.
3. After you have observed this angle, remove the hitch bar from the vehicle and place it into the hitch box on the travel trailer. Secure it with (1) “OCL.” Observe that angle.
4. The goal is to have both angles matching or mirroring each other. Remembering the angle sticking out of the tow vehicle, maneuver the angle of the hitch box by tensioning or untensioning the spring bars with the spring bar jacks. (This is like maneuvering a wheelbarrow. Your arms are the jack and the wheelbarrow handles are the spring bars.)
5. Once you see the hitch box angle matches the angle from the town vehicle, remove the hitch bar from the hitch box on the travel trailer and replace it in the tow vehicle pinning securely into place.
6. Back up toward the travel trailer again. This time stop 3-4 inches from the hitch box and adjust the height of the hitch box opening by moving the travel trailer tongue jack up or down. Center the hitch bar in the opening.
7. Back the hitch bar into the hitch box. Don’t be afraid to be somewhat aggressive.
8. Finish the connection by camming the hitch bar securely into place with the “OCL’s.” Install the safety keys, connect the safety cable, safety chains, and electrical cord.
9. Engage weight distribution to your towing position by tensioning the spring bars using the spring bar jacks. Also use the height indicator marks on the jacks making sure both sides are equal height for towing.
10. Raise the tongue jack of the travel trailer completely up and out of the way. Put away tools and unchock wheels.
11. Lastly, check the strut assemblies, being sure they are tight.

HENSLEY ARROW TOWING SYSTEM UNHOOKING

1. Chock travel trailer tires.
2. Put the travel trailer tongue jack down, raising the travel trailer enough to take the tongue weight of the trailer off the tow vehicle. (This can be measured prior to hooking up or could be the measurement given when the hitch was ordered - measurement from the ground to the top inside of 2" receiver on vehicle - trailer not hooked up and vehicle running).
3. Start un-tensioning the spring bars using the spring bar jacks and the supplied ratchet wrench. As you un-tension them, you will start to see the spring bar become "sloppy loose". Continue un-tensioning the jacks until either they stop or until they start to tighten again (this is called reverse tension). This process will take into account any angles between your vehicle and the travel trailer (side to side/front to back).
4. Disconnect electrical cord, safety cable and safety chains. Remove safety keys and open "OCL's."
5. Straighten vehicle wheels and pull away from travel trailer. Level trailer for sleeping and refrigeration.

Frequently Asked Questions

Question: Why does the trailer shift to the left or right when braking?

Answer: This is a common question we get with a Hensley Arrow. The trailer wants to shift to the left or right because of the way the linkage system is designed. A feeling of the trailer bumping the vehicle is felt. This is the result of the trailer brakes **Not** being applied soon enough. The trailer is actually traveling faster than the vehicle and has more momentum so it takes more to slow it down than your vehicle, hence the bumping feeling occurs. Most brake controllers have a Gain Control that can be adjusted so the trailer brakes will come on sooner. Tweak your brake controller so your trailer brakes are being applied shortly before your vehicle brakes. This should eliminate that feeling on mid to heavy stops.

Question: How tight should the strut bars be?

Answer: Good and tight. Generally finger tight and 1/2 turn more. They should not rattle on the pins. You do not want to put all your weight behind you just to get the nut to turn another flat turn. That's too tight. Make it a maintenance check every time you hookup. They WILL loosen up a bit as you tow for several miles and hook and unhook a few times. The strut bars are your sway control. If they are loose, you will have sway.

Question: How much should I tension the jack assemblies?

Answer: Each combination will be different as to how much tension you apply. A heavier trailer on a lighter suspension vehicle will require more tension than a lighter trailer on a heavier suspension. The feel of the ride is what you are looking to achieve since sway is eliminated no matter how much you tension the jacks. Generally, most people need to tension the jacks up between the 2nd and 3rd marks or higher. Spring bars cannot be over tensioned.

Question: The spring bars tend to fall out of the housing when I un-tension the jacks? Why?

Answer: Chances are the spring loaded retainer pin on the grease fitting has not locked into the groove of the spring bar. You may need to adjust the grease fitting in or out a 1/2 turn at a time until the bar locks for proper installation. (See Fig. 1-18 Page 14)

Question: Can I weld the frame brackets onto the trailer frame instead of using the U-Bolts?

Answer: We Do Not Recommend it. The frame brackets are designed to slide when too much force is put on them from the strut bars. If the brackets don't slide then it's possible for the strut bar to be damaged.

Question: I have an aluminum, Alco frame on my trailer. Does that change the install process?

Answer: With an Alco frame, you do not use the U-Bolts because they can crush the frame when applying the torque. Instead we use a 1" spacer and bolts with nuts & washers (See Page 10 bottom pic). Everything else stays the same.

Question: I recently bought a new tow vehicle and need to exchange my hitchbar for a different offset. What's the procedure for doing this?

Frequently Asked Questions cont.

Answer: As long as you are the original owner you can exchange your hitchbar for a different offset. Call us with your new tow vehicle measurement and our Hensley specialists will help you decide which hitchbar would be a better suited for your combo. We will charge you for the new bar plus a shipping & handling fee. You then send back the other bar with a RA# for a refund on the bar.

Question: I am using a 2" Hitchbar offset now with my current setup. Can I get other offsets from your company if needed with a different vehicle?

Answer: We do offer 5 different hitchbars depending on the height differences between your trailer and vehicle. They come in Straight, 2", 4", 6" and 8" offsets.

Question: Can the hitchbar offset rise up as well as drop down out of the vehicle?

Answer: Yes, although most offsets drop down, some vehicle/trailer combos require the offset to rise up out of the vehicle to make everything level. If you are not sure which way it goes, try it both ways.

Question: What is the weight rating of the Hensley Arrow?

Answer: The weight rating of the Hensley is up to 14,000 lbs trailer weight and 1400# tongue weight.

Question: I've heard that hooking up can be difficult at times. Is there any helpful tips on making it easier?

Answer: Hooking up can be difficult at times but not impossible. Practice, practice, practice makes perfect. The idea is to mirror the angles to each other using your jack assemblies to change the angle of the hitchbox.

Spraying some lubricant on the bar or inside the hitchbox will help. The hitch helper is another helpful tool in hooking up.

Question: How often should I grease the ball?

Answer: Grease the ball when you first install it and once a year after that.

Question: How often should I grease the spring bars?

Answer: The spring bars should be greased liberally every 500 miles. You cannot over grease them but it is also very important that they do not run dry. Damage can occur.

Question: Does the Lifetime Warranty transfer if I sell my Hensley Arrow hitch?

Answer: No, The Lifetime Warranty is only good for the original owner, however it may be possible for the 2nd owner to purchase a lifetime warranty from us if it meets certain requirements. Call for details!

Question: Does Hensley Mfg sell any other towing products?

Answer: We make the McKesh Portable Towing Mirrors, which we feel are the best on the market. We also sell a Hensley Arrow Emergency Kit, Hitch Helper and electrical and safety chain extensions. All great products for your towing needs.

