

# Blaze King

## OWNER'S INSTALLATION AND OPERATION Manual Blaze King Catalyst Stove MODELS

**KING KE1107 / KEJ1107**  
CLASSIC, ULTRA & LEGS MODELS  
**PRINCESS PE1006 / PEJ1006**  
CLASSIC, ULTRA & LEG MODELS



**CATALYTIC SOLID FUEL WOOD HEATERS**

**SAVE THESE INSTRUCTIONS**

Manufactured By

**Valley Comfort Systems Inc.**  
1290 Commercial Way  
Penticton, BC V2A 3H5  
CANADA  
Phone: 250-493-7444  
Fax: 250-493-5833

**Blaze King Industries**  
146 A Street  
Walla Walla, WA 99362  
U.S.A.  
Phone: (509) 522-2730  
Fax: (509) 522-9803



**E**

*Pour la version française de nos manuels S.V.P. vous référez à notre site web: [www.blazeking.com](http://www.blazeking.com)*



# BLAZE KING CATALYST STOVE - PE(J) 1006 POÊLE À BOIS CATALYTIQUE

WH -

LISTED ROOM HEATER, SOLID FUEL TYPE / APPAREILLE APPROUVÉE DE TYPE CARBURANT  
Also for use in MOBILE HOMES / SOLIDE Aussi pour l'usage dans les MAISONS MOBILES  
MODEL / MODÈLE: PE 1006/PEJ 1006 Tested to / Testé: UL 1482 (9/88) / CSA B366.2 ULC S627  
CERTIFIED IN BOTH UNITED STATES AND CANADA / CERTIFIÉ POUR LES ETATS-UNIS ET LE CANADA

**PREVENT HOUSE FIRES-** Install and use only in accordance with Blaze King's installation and operation instructions. Contact local building or fire officials about restrictions and installation inspection in your area.

Flue size is 6"

**CHIMNEYS:** DO NOT CONNECT THIS UNIT TO A CHIMNEY FLUE SERVING ANOTHER APPLIANCE. Except for installation detailed below, use 6" listed factory built chimney suitable for use with solid fuels and conforming to, ULC629 in Canada or UL-103HT in the USA or a masonry residential type chimney.

Mobile Home, residential close clearance, and residential alcove installations require a 6" listed double wall close clearance chimney connector, with matching listed factory built chimney suitable for use with solid fuels and conforming to, ULC629 in Canada or UL-103HT in the USA.

Mobile Home installations are only allowed with a roof exit. Do not install in a sleeping room.

Alcove minimum width 47", maximum depth 48", minimum height 49" above stove top.

Passing through a wall or ceiling requires special methods: see instructions and local building codes.

Electrical rating: 115 VAC, 60 Hz, 0.58 Amps. Risk of electrical shock. Disconnect power before servicing unit. Do not route power cord in front of or beneath heater.

**POUR EMPÊCHER UNE INCENDIE** Installer et employer seulement selon le manuel des directives d'installation de Blaze King. Contacter les fonctionnaires locaux de bâtiment ou de feu au sujet des restrictions et de l'inspection d'installation dans votre secteur.

La taille de conduite de cheminée est 6"

**CHEMINÉE :** NE PAS CONNECTER CETTE UNITÉ À UNE CONDUITE DE CHEMINÉE SERVANT UN AUTRE APPAREIL. Excepté pour les installation détaillée ci-dessous, employer 6" avec une cheminée approuvée d'usine appropriée pour l'utilisation avec les combustibles solides et conformément à ULC629 au Canada ou à UL-103HT aux Etats-Unis ou un type de cheminée résidentiel de maçonnerie.

Le dégagement étroit de maison mobile, et de les installations résidentielles de chambrette exigent 6" double connecteur de cheminée approuvé au dégagement de fin de mur, avec une cheminée approuvée construite par une usine appropriée pour l'utilisation avec les combustibles solides et conformément à, l' ULC629 au Canada ou l' UL-103HT AUX Etats-Unis.

On permet seulement l'installation dans une maison mobile avec une sortie de toit. Ne pas installer dans une salle de sommeil.

Largeur minimum de 47" de chambrette " profonde maximum 48 " taille minimum 49 " au -dessus du poêle.

Pour passer au travers d'un mur ou d'un plafond ceci exige des méthodes spéciales : voir les directives et les codes locaux de bâtiment.

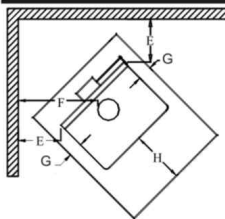
Estimation électrique: 115VAC, 60 hertz, 0.58 ampère de risque de choc électrique, débrancher l'alimentation électrique avant l'entretien de l'unité.

Ne pas conduire le cordon de secteur devant ou sous l'appareille.

**MINIMUM CLEARANCES TO COMBUSTIBLES** (See owners manual for complete description of all requirements)

**DÉGAGEMENTS MINIMUM AUX COMBUSTIBLES** (voir les directives d'installation pour la description complète de toutes les conditions).

| Residential Installations / Installations résidentielles  | A            | B           | C              | D            | E            | F               |
|---|--------------|-------------|----------------|--------------|--------------|-----------------|
| Roof exit, parallel and corner<br>Sortie de toit, parallèle et coin   | 16"<br>410mm | 9"<br>230mm | 26.5"<br>675mm | 16"<br>410mm | 14"<br>360mm | 24.75"<br>629mm |
| Roof exit, reduced side. Use side shields<br>Sortie de toit, côté réduits. Utiliser des boucliers latéraux  | 10"<br>254mm | 9"<br>230mm | 20.5"<br>520mm | 16"<br>410mm |              |                 |
| Roof exit, reduced corner. Use side shields and either fan kit or rear shield<br>Sortie de toit, coin réduits. Utiliser des boucliers latéraux et kit de ventilateur/bouclier arrière   |              |             |                |              | 6"<br>153mm  | 16.75"<br>425mm |
| Roof exit, close clearance. Use side shields and either fan kit or rear shield. Sortie de toit, dégagement étroit, Utiliser des boucliers latéraux, et kit de ventilateur/bouclier arrière  | 10"<br>254mm | 6"<br>153mm | 20.5"<br>520mm | 13"<br>330mm |              |                 |
| Wall exit, parallel and corner<br>Sortie, parallèle et coin   | 16"<br>410mm | 9"<br>230mm | 26.5"<br>675mm | 18"<br>460mm | 14"<br>360mm | 24.75"<br>629mm |
| Wall exit, reduced side. Use side shields<br>Sortie de mur, côté réduit. Utiliser des boucliers latéraux  | 10"<br>254mm | 9"<br>230mm | 20.5"<br>520mm | 18"<br>460mm |              |                 |
| Wall exit, reduced corner. Use side shields and either fan kit or rear shield<br>Sortie de mur, coin réduit. Utiliser des boucliers latéraux/ kit de ventilateur/bouclier arrière   |              |             |                |              | 7"<br>180mm  | 17.75"<br>451mm |
| Alcove roof exit. Use side shields and either fan kit or rear shield<br>Chambrette, sortie de toit. Utiliser des boucliers latéraux/et kit de ventilateur/ bouclier arrière   | 10"<br>254mm | 6"<br>153mm | 20.5"<br>520mm | 13"<br>330mm |              |                 |
| <b>Mobile Home Installations / Installations pour maison mobile</b>   |              |             |                |              |              |                 |
| Roof exit parallel and corner. Use side shields, either fan kit or rear shield and outside air kit<br>La sortie du toit, parallèle et le coin utiliser les boucliers latéraux, ou kit de ventilateur ou un bouclier et un kit d'air extérieur | 10"<br>254mm | 6"<br>153mm | 20.5"<br>520mm | 13"<br>330mm | 6"<br>153mm  | 16.75"<br>425mm |



Floor protection may be any non-combustible material or Listed Floor Protector, and must extend at least 18" (456mm) (in Canada) or 16"(406mm) (in U.S.A.), in front of the loading door opening.

Minimum size is 32"x 44" (813 x 1118mm) in U.S.A or 43" x 55" (1092 x 1397mm) in Canada (18"(456mm) front / 8" (203mm) rear / 8" (203mm) sides).

U.S. ENVIRONMENTAL PROTECTION AGENCY- Certified to comply with July, 1990 particulate emission standards.

This wood heater contains a catalytic combustor, which needs periodic inspection and replacement for proper operation. Consult owner's manual for further information.

It is against the law to operate this wood heater in a manner inconsistent with operating instructions in the owner's manual, or if the catalytic element is deactivated or removed.

\*Operate with doors closed. Open door to feed fire ONLY. \*Do not obstruct combustion air openings. Provide adequate outside air for combustion. \* Use only ceramic glass if replacement is necessary, 5 mm. Thickness

La protection de plancher peut être n'importe quel matériel non combustible ou Protecteur de plancher approuvé, et doit se prolonger au moins, 18 "(456mm)(au Canada) ou 16 "(406mm)(aux Etats-Unis), devant l'ouverture de la porte de chargement. La taille minimum est de 32 "x 44" (813 x 1118mm) aux Etats-Unis ou 43" x 55" (1092 x 1397mm) au Canada (18 "(456mm) avant / 8"(203mm) po à l'arrière / 8"(203mm) Cote).

AGENCE DE PROTECTION DE L'ENVIRONNEMENT DES États-Unis - certifiée pour se conformer aux normes d'émission de juillet 1990. Cette appareille à bois contient une chambre de combustion catalytique, qui a besoin d'inspection et de remplacement périodiquement pour le fonctionnement approprié. Consulter le manuel d'installation pour de plus amples informations. Il est contre la loi d'actionner cette appareille à bois en quelque sorte con tradicatoire avec les consignes d'utilisation du manuel, ou si l'élément catalytique est enlevé ou désactivé. \* Fonctionner avec les portes fermées. Ouvrir la porte pour alimenter le feu SEULEMENT. \*Ne pas obstruer l'ouverture d'air de combustion. Fournir de l'air extérieur adéquat pour la combustion. \* Employer seulement le verre en céramique si le remplacement est nécessaire, d'une épaisseur de 5mm.

MANUFACTURED IN:

USA:  
Blaze King Industries  
146A Street  
Walla Walla, WA.  
99362

Canada:  
Valley Comfort Systems  
1290 Commercial Way  
Penticton, B.C.  
V2A 3H5

MANUFACTURE DATE

JAN  FEB  MAR  APR  MAY  JUN   
JUL  AUG  SEP  OCT  NOV  DEC   
2010  2011  2012  2013  2014  2015

H - 16" (406 mm) in U.S.A.  
18" (456 mm) in Canada

G - 2.5"(64 mm) in U.S.A.  
8" (203 mm) in Canada

0217PE Rev 07/2010



# BLAZE KING CATALYST STOVE - KE(J) 1107 POÊLE À BOIS CATALYTIQUE

WH -

LISTED ROOM HEATER, SOLID FUEL TYPE / APPAREILLE APPROUVÉE DE TYPE CARBURANT  
Also for use in MOBILE HOMES / SOLIDE Aussi pour l'usage dans les MAISONS MOBILES  
MODEL / MODÈLE: KE 1107/KEJ 1107 Tested to / Testé: UL 1482 (9/88) /CSA B366.2 ULC S627  
CERTIFIED IN BOTH UNITED STATES AND CANADA / CERTIFIÉ POUR LES ETATS-UNIS ET LE CANADA

**PREVENT HOUSE FIRES-** Install and use only in accordance with Blaze King's installation and operation instructions. Contact local building or fire officials about restrictions and installation inspection in your area.

Flue size is 8"

**CHIMNEYS: DO NOT CONNECT THIS UNIT TO A CHIMNEY FLUE SERVING ANOTHER APPLIANCE.** Except for installation detailed below, use 8" listed factory built chimney suitable for use with solid fuels and conforming to, ULC629 in Canada or UL-103HT in the USA or a masonry residential type chimney.

Mobile Home, residential close clearance, and residential alcove installations require a 8" listed double wall close clearance chimney connector, with matching listed factory built chimney suitable for use with solid fuels and conforming to, ULC629 in Canada or UL-103HT in the USA.

Mobile Home installations are only allowed with a roof exit. Do not install in a sleeping room.

Alcove minimum width 47", maximum depth 48", minimum height 49" above stove top.

Passing through a wall or ceiling requires special methods: see instructions and local building codes.

Electrical rating: 115 VAC, 60 Hz, 0.58 Amps. Risk of electrical shock. Disconnect power before servicing unit. Do not route power cord in front of or beneath heater.

**POUR EMPÊCHER UNE INCENDIE** Installer et employer seulement selon le manuel des directives d'installation de Blaze King. Contacter les fonctionnaires locaux de bâtiment ou de feu au sujet des restrictions et de l'inspection d'installation dans votre secteur.

La taille de conduite de cheminée est 8"

**CHEMINÉE : NE PAS CONNECTER CETTE UNITÉ À UNE CONDUITE DE CHEMINÉE SERVANT UN AUTRE APPAREIL.** Excepté pour les installation détaillée ci-dessous, employer 8" avec une cheminée approuvée d'usine appropriée pour l'utilisation avec les combustibles solides et conformément à ULC629 au Canada ou à UL-103HT aux Etats-Unis ou un type de cheminée résidentiel de maçonnerie.

Le dégagement étroit de maison mobile, et de les installations résidentielles de chambrette exigent 8" double connecteur de cheminée approuvée au dégagement de fin de mur, avec une cheminée approuvée construite par une usine appropriée pour l'utilisation avec les combustibles solides et conformément à, l' ULC629 au Canada ou l' UL-103HT AUX Etats-Unis.

On permet seulement l'installation dans une maison mobile avec une sortie de toit. Ne pas installer dans une salle de sommeil.

Largeur minimum de 47" de chambrette " profondeur maximum 48 " taillenminimum 49 " au -dessus du poêle.

Pour passer au travers d'un mur ou d'un plafond ceci exige des méthodes spéciales : voir les directives et les codes locaux de bâtiment.

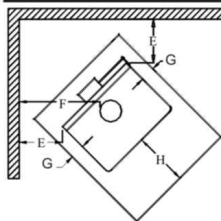
Estimation électrique: 115VAC, 60 hertz , 0.58 ampère de risque de choc électrique, débrancher l'alimentation électrique avant l'entretien de l'unité.

Ne pas conduire le cordon de secteur devant ou sous l'appareille.

**MINIMUM CLEARANCES TO COMBUSTIBLES** (See owners manual for complete description of all requirements)

**DÉGAGEMENTS MINIMUM AUX COMBUSTIBLES** (voir les directives d'installation pour la description complète de toutes les conditions).

| Residential Installations / Installations résidentielles  | A            | B            | C            | D              | E            | F            |
|---|--------------|--------------|--------------|----------------|--------------|--------------|
| Roof exit, parallel and corner<br>Sortie de toit, parallèle et coin   | 16"<br>410mm | 9"<br>230mm  | 27"<br>690mm | 16.5"<br>420mm | 14"<br>360mm | 25"<br>640mm |
| Roof exit, reduced side. Use side shields<br>Sortie de toit, côté réduits. Utiliser des boucliers latéraux  | 10"<br>254mm | 9"<br>230mm  | 21"<br>534mm | 16.5"<br>420mm |              |              |
| Roof exit, reduced corner. Use side shields and either fan kit or rear shield<br>Sortie de toit, coin réduits. Utiliser des boucliers latéraux et kit de ventilateur/bouclier arrière   |              |              |              |                | 6"<br>153mm  | 17"<br>432mm |
| Roof exit, close clearance. Use side shields and either fan kit or rear shield. Sortie de toit, dégagement étroit, Utiliser des boucliers latéraux, et kit de ventilateur/bouclier arrière  | 10"<br>254mm | 6"<br>153mm  | 21"<br>534mm | 13.5"<br>343mm |              |              |
| Wall exit, parallel and corner<br>Sortie, parallèle et coin   | 16"<br>410mm | 11"<br>280mm | 27"<br>690mm | 18.5"<br>470mm | 14"<br>360mm | 25"<br>640mm |
| Wall exit, reduced side. Use side shields<br>Sortie de mur, côté réduit. Utiliser des boucliers latéraux  | 10"<br>254mm | 11"<br>280mm | 21"<br>534mm | 18.5"<br>470mm |              |              |
| Wall exit, reduced corner. Use side shields and either fan kit or rear shield<br>Sortie de mur, coin réduit. Utiliser des boucliers latéraux/ kit de ventilateur/bouclier arrière   |              |              |              |                | 7"<br>180mm  | 18"<br>460mm |
| Alcove roof exit. Use side shields and either fan kit or rear shield<br>Chambrette, sortie de toit. Utiliser des boucliers latéraux/et kit de ventilateur/ bouclier arrière   | 9"<br>230mm  | 6"<br>153mm  | 20"<br>510mm | 13.5"<br>343mm |              |              |
| <b>Mobile Home Installations / Installations pour maison mobile</b>   |              |              |              |                |              |              |
| Roof exit parallel and corner. Use side shields, either fan kit or rear shield and outside air kit<br>La sortie du toit, parallèle et le coin utiliser les boucliers latéraux, ou kit de ventilateur ou un bouclier et un kit d'air extérieur | 10"<br>254mm | 6"<br>153mm  | 21"<br>534mm | 13.5"<br>343mm | 6"<br>153mm  | 17"<br>432mm |



Floor protection may be any non-combustible material or Listed Floor Protector, and must extend at least 18" (456mm) (in Canada) or 16" (406mm) (in U.S.A.), in front of the loading door opening. Minimum size is 34"x 45" (864x1143mm) in U.S.A or 46" x 56" (1168x1422mm) in Canada (18" (456mm) front / 8" (203mm) rear / 8" (203mm) sides). NOTE: Minimum size for KE Ultra is 35" x 45" in U.S.A. or 47" x 56" in Canada.

U.S. ENVIRONMENTAL PROTECTION AGENCY- Certified to comply with July, 1990 particulate emission standards.

This wood heater contains a catalytic combustor, which needs periodic inspection and replacement for proper operation. Consult owner's manual for further information.

It is against the law to operate this wood heater in a manner inconsistent with operating instructions in the owner's manual, or if the catalytic element is deactivated or removed.

\*Operate with doors closed. Open door to feed fire ONLY. \*Do not obstruct combustion air openings. Provide adequate outside air for combustion. \* Use only ceramic glass if replacement is necessary, 5 mm. Thickness

La protection de plancher peut être n'importe quel matériel non combustible ou Protecteur de plancher approuvé, et doit se prolonger au moins, 18 "(456mm)(au Canada) ou 16 "(406mm)(aux Etats-Unis), devant l'ouverture de la porte de chargement. La taille minimum est de 34"x 45" (864x1143mm) aux Etats-Unis ou 46" x 56" (1168x1422mm) au Canada (18 "(456mm) avant / 8"(203mm) po à l'arrière / 8"(203mm) Cote).La taille min. pour KE Ultra est 35" x 45" aux Etats-Unis ou 47" x 56" au Canada.

AGENCE DE PROTECTION DE L'ENVIRONNEMENT DES États-Unis - certifiée pour se conformer aux normes d'émission de juillet 1990. Cette appareil à bois contient une chambre de combustion catalytique, qui a besoin d'inspection et de remplacement périodiquement pour le fonctionnement approprié. Consulter le manuel d'installation pour de plus amples informations. Il est contre la loi d'actionner cette appareil à bois en quelque sorte con tradictoire avec les consignes d'utilisation du manuel, ou si l'élément catalytique est enlevé ou désactivé. \* Fonctionner avec les portes fermées. Ouvrir la porte pour alimenter le feu SEULEMENT. \*Ne pas obstruer l'ouverture d'air de combustion. Fournir de l'air extérieur adéquat pour la combustion. \* Employer seulement le verre en céramique si le remplacement est nécessaire, d'une épaisseur de 5mm.

MANUFACTURED IN:

MANUFACTURE DATE

USA:

Blaze King Industries  
146A Street  
Walla Walla, WA.  
99362

Canada:

Valley Comfort Systems  
1290 Commercial Way  
Penticton, B.C.  
V2A 3H5

JAN  FEB  MAR  APR  MAY  JUN   
JUL  AUG  SEP  OCT  NOV  DEC   
2010  2011  2012  2013  2014  2015

H - 16" (406 mm) in U.S.A.  
18" (456 mm) in Canada

G - 2" (64 mm) in U.S.A.  
8" (203 mm) in Canada

0217KE Rev 07/2010

# Safety Warning

---

**IF THIS BLAZE KING STOVE IS NOT PROPERLY INSTALLED OR OPERATED, A HOUSE FIRE MAY RESULT. TO REDUCE THE RISK OF FIRE, FOLLOW THE INSTALLATION INSTRUCTIONS. CONTACT LOCAL BUILDING OR FIRE OFFICIALS ABOUT RESTRICTIONS AND INSTALLATION INSPECTION REQUIREMENTS IN YOUR AREA.**

THIS STOVE MUST BE CONNECTED TO EITHER:

1. A LISTED FACTORY BUILT CHIMNEY SUITABLE FOR USE WITH SOLID FUELS AND CONFORMING TO, ULC629 IN CANADA OR UL-103HT IN THE USA.
2. A CODE-APPROVED MASONRY CHIMNEY WITH A FLUE LINER.

**PLEASE READ THIS ENTIRE MANUAL BEFORE YOU INSTALL AND USE YOUR NEW ROOM HEATER. FAILURE TO FOLLOW INSTRUCTIONS MAY RESULT IN PROPERTY DAMAGE, BODILY INJURY, OR EVEN DEATH.**

This unit is certified by the United States Environmental Protection Agency. Certified to comply with July, 1990 particulate emissions standards.

**The following statement is required by the Environmental Protection Agency:**

"This wood heater contains a catalytic combustor, which needs periodic inspection and replacement for proper operation. It is against the law to operate this wood heater in a manner inconsistent with operating instructions in this manual, or if the catalytic element is deactivated or removed."

See pages 36&37 for Catalytic Combustor, Testing and Replacement.

## SAVE THESE INSTRUCTIONS

### NOTE

**Due to high efficiencies of these units, Blaze King recommends the use of double wall stove pipe from the stove top to either wall or roof exit.**

**No two installations are identical, specific performance and use will vary with each application.**

**A minimum of 36" vertical rise is recommended prior to using any elbows.**

# To Our Valued Customers

Dear Customer:

Thank you for purchasing a **Blaze King**, King or Princess catalytic wood burning stove (hereafter referred to as "stove").

This owner's manual explains the steps required to safely assemble, install, operate, and maintain your new stove. Be a responsible stove owner; carefully read these requirements for safe installation and proper operation BEFORE installing and using your stove.

Obtain permits from the Building Inspector or Fire Department, if local laws require. Check local building and fire codes before installing your stove. When you have completed the installation, have it checked by your local inspector. Disregarding inspection and code requirements may jeopardize your homeowner's insurance. Since some insurance carriers require notification of a stove installation, contact your insurance agent. We want your **Blaze King** to give you a lifetime of trouble-free operation.

While we have made, every effort to make these instructions as complete as possible, some installation or operating conditions may not be covered. If you have any questions that are not answered here, contact your **Blaze King** dealer, Local Building Inspector, Fire Department, or our customer service department at **Blaze King**, Walla Walla, WA 509-522-2730 (in Canada 250-493-7444).

The Management and Employees of

*Blaze King Industries*

**KEEP THIS MANUAL FOR FUTURE REFERENCE.**

# Table Of Contents

| <b>Section</b>                                 | <b>Page</b> |
|--|-------------|
| APPROVAL LABEL .....                           | 2-3         |
| SAFETY WARNING .....                           | 4           |
| TABLE OF CONTENTS .....                        | 6-7         |
| WARRANTY .....                                 | 8           |
| DEFINITIONS .....                              | 9           |
| Alcove .....                                   | 9           |
| Building Codes and Permits .....               | 9           |
| Bypass .....                                   | 9           |
| Catalytic Combustor .....                      | 9           |
| Chimney .....                                  | 9           |
| Chimney Connector .....                        | 9           |
| Chimney, Masonry .....                         | 10          |
| Chimney, Prefabricated .....                   | 10          |
| Close Clearance .....                          | 10          |
| Combustible Material .....                     | 10          |
| Combustion Air Intake .....                    | 10          |
| Door, Loading .....                            | 10          |
| Draft .....                                    | 10          |
| Fans .....                                     | 10          |
| Fan Speed Control .....                        | 10          |
| Firebox .....                                  | 10          |
| Flame Shield .....                             | 10          |
| Flammable Liquids .....                        | 10          |
| Floor Protector .....                          | 10          |
| Flue .....                                     | 10          |
| Fuel .....                                     | 10          |
| Hearth .....                                   | 11          |
| Ice - Formation and Prevention .....           | 11          |
| Inspections .....                              | 11          |
| Listed .....                                   | 11          |
| Mobile Home .....                              | 11          |
| Outside Air Kit .....                          | 11          |
| Thermometer .....                              | 11          |
| Thermostat .....                               | 11          |
| Thimble .....                                  | 11          |
| Tie Down Screws .....                          | 11          |
| SAFETY .....                                   | 12          |
| Chimney Fire .....                             | 12          |
| Smoke Detectors .....                          | 12          |
| Fire Extinguishers .....                       | 12          |
| Building and Fire Codes .....                  | 12          |
| Children .....                                 | 12          |
| Chimneys .....                                 | 12          |
| Clearances to Combustible Materials .....      | 13          |
| Creosotes Formation and Need for Removal ..... | 13          |
| Fuel .....                                     | 13          |
| Electrical Power .....                         | 14          |
| Disposal of Ashes .....                        | 14          |
| Loading Door .....                             | 14          |
| SPECIFICATIONS .....                           | 15          |
| PREPARATION AND ASSEMBLY .....                 | 16          |
| Tools Needed for Installation .....            | 16          |
| Planning for Your Stove Placement .....        | 16          |
| Reduced Wall Clearance .....                   | 16          |
| Inspect Your Chimney .....                     | 16          |
| Chimney Height Affects Draft .....             | 17          |
| Stove Assembly .....                           | 17          |
| Product Inspection .....                       | 17          |
| Installing the Combustor Assembly .....        | 17          |
| Flame Shield .....                             | 17          |
| Installation & General Instructions .....      | 18          |
| Fig. 7, Floor Protector .....                  | 18          |

# Table Of Contents

| <b>Section</b>   | <b>Page</b> |
|--|-------------|
| Venting Systems  | 18          |
| Chimney Connector  | 18          |
| Fig. 8, Flue Gas Direction   | 19          |
| Connection to a Masonry Chimney  | 19          |
| Fig. 9, Masonry Chimney Construction   | 19          |
| Fig. 10, Fire stopping   | 19          |
| Fig. 11, Clearances, Masonry to Combustibles   | 20          |
| Fig. 12, Minimum Chimney Height  | 20          |
| Fig. 13, Brick Chimney Thimble   | 20          |
| Fig. 14, Masonry Chimney Construction  | 21          |
| Figs. 15 & 16, Metal Prefabricated Thimble   | 21          |
| Connection to a Metal Prefabricated Chimney  | 22          |
| Figs. 17 & 18, Metal Prefabricated Chimney, Through Roof                             | 22          |
| Figs. 19 & 23, Metal Prefabricated Chimney, Through Wall                             | 22          |
| Clearances to Combustible Surfaces   | 23          |
| Table #1, Clearances To Combustibles   | 23          |
| Figs. 21, 22, 23, 24, 25, 26 Clearance Illustrations                                 | 23          |
| Installation Instructions  | 24          |
| Residential, Roof Exit, Standard and Reduced Clearance, Prefabricated Chimney Fig 27 | 25          |
| Residential, Wall Exit, Standard and Reduced Clearance, Prefabricated Chimney Fig 28 | 26          |
| Residential, Wall Exit, Standard and Reduced Clearance, Masonry Chimney Fig 29       | 27          |
| Mobile Home and Residential Alcove, Roof Exit, Prefabricated Chimney Fig 30          | 28          |
| Fig. 31, Cutaway View With Major Internal Part                                       | 29          |
| OPTIONAL ACCESSORIES   | 30          |
| Side Shields   | 30          |
| Rear Shield  | 30          |
| Fans   | 31          |
| Outside Air  | 32          |
| OPERATION  | 33          |
| Fuel   | 33          |
| Initial Start-Up Sequence  | 33          |
| Optimum Thermostat Setting   | 34          |
| Fan Operation  | 34          |
| Disposal of Ashes  | 35          |
| Reloading  | 35          |
| MAINTENANCE  | 36          |
| Ash Removal  | 36          |
| Authorized Service Representative  | 36          |
| Creosote; Formation, Inspection, Removal   | 36          |
| Loading Door Gasket, Inspection, Replacement   | 36          |
| Catalytic Combustor, Testing, Cleaning   | 37          |
| Catalytic Combustor, Replacement   | 38          |
| Door Glass, Cleaning   | 38          |
| Door Glass, Replacement  | 38          |
| Chimney Drafts   | 38          |
| Fan Assembly   | 39          |
| Paint  | 39          |
| Rheostat-Replacement   | 39          |
| TROUBLESHOOTING  | 40          |
| Chimney Fire   | 40          |
| Heat, not enough   | 41          |
| Heat, too much   | 41          |
| Fans   | 41          |
| Creosote   | 42          |
| Catalytic Combustor  | 42          |
| Dirty Door Glass   | 42          |
| REPLACEMENT PARTS PE1006   | 43-46       |
| REPLACEMENT PARTS KE1107   | 47-50       |
| REPLACEMENT PARTS Z1714 FANKIT   | 51          |
| ADDENDUM—YOUR FIRST FIRE   | 52          |
| Stoves Aequipped with ASH DRAWERS  | 54          |
| Sud Chemie Prototech Major Cleaning Procedures                                       | 55-57       |

# Warranty

## BLAZE KING LIMITED WOODSTOVE WARRANTY - KE/PE KEJ/PEJ

### WHAT THE WARRANTY COVERS:

This warranty contains different terms which cover different parts of the stove. BLAZE KING warrants the STEEL COMPONENTS of this BLAZE KING stove, which is delivered with this warranty, against defects in material or workmanship to you, the original retail purchaser (hereafter referred to as purchaser), for a period of up to five (5) years following the date of original retail purchase, subject to the provisions of the RESPONSIBILITIES OF THE COMPANY below. BLAZE KING warrants the FAN ASSEMBLY, MODULAR THERMOSTAT, FRONT DOOR GASKET, and WOOD HANDLES of this BLAZE KING, which is delivered with this warranty, against defects in material or workmanship, to the purchaser, for a period of one (1) year following the date of original retail purchase, subject to the provisions of the RESPONSIBILITIES OF THE COMPANY below. The CATALYTIC COMBUSTOR is under warranty by Süd Chemie Prototech of Needham, Massachusetts for six (6) years from the date of original retail purchase. The purchaser shall pay the following share of the then current retail price for the combustor: The first three (3) years no charge, 4th year 70%; 5th year 80%; 6th year 90%. The Combustor must be returned to your dealer along with a completed COMBUSTOR FAILURE REPORT. Warranty WILL NOT BE GIVEN until Süd Chemie Prototech completes an inspection and analysis of the defective combustor.

### WHAT THE WARRANTY DOES NOT COVER:

Unless otherwise provided by law or covered by this warranty, BLAZE KING is not responsible for removal, transportation or re-installation of any product repaired or replaced pursuant to this warranty. BLAZE KING shall in no event be liable for special, incidental, consequential, indirect or other similar damages arising from the breach of the warranty, even if BLAZE KING has been advised of the possibility of such damages. Some states/provinces do not allow the exclusion or limitation of incidental or consequential damages, so the above limitation or exclusion may not apply to you. BLAZE KING limits all implied warranties, if any, including the warranties of merchantability or fitness for particular purpose, to one (1) year from the date of original retail purchase. Some states/provinces do not allow limitations on how long implied warranty lasts, so the above limitation may not apply to you. Actions for breach of this warranty must be brought within one (1) year of The expiration of this warranty. There is no warranty on paint, ceramics, glass, bricks or gold plating. No person is authorized to modify this warranty or to make any additional warranties on behalf of the manufacturer, BLAZE KING. This warranty applies to units sold, installed and for use in the USA or Canada.

### HOW YOU CAN GET SERVICE:

If this product requires repair or replacement due to defects in material or workmanship covered by this warranty, contact your Blaze King dealer and explain the defect. If the dealer does not repair or replace the product to your satisfaction, contact the Service Department of Blaze King in the U.S.A. at 1-509-522-2730 and in Canada at 1-250-493-7444 or write to Blaze King at one of the addresses at the end of this warranty. Please explain the defect and state the model, serial number, date of retail purchase, and the name and address of your Blaze King dealer. Blaze King may request that the defective part, parts, or the entire stove, be shipped to one of Blaze King's manufacturing locations at the purchaser's expense.

### RESPONSIBILITIES OF THE COMPANY:

IF the purchaser has complied with all of the terms and conditions of this warranty and IF the purchaser has notified BLAZE KING of a defect prior to the expiration of the respective warranty period and after shipment, BLAZE KING will either repair or replace the product, AT ITS ELECTION, or MAY ELECT to refund a portion of the purchase price, based on the formula below, if it cannot readily and quickly provide the purchaser with a replacement. The repaired product or replacement will be returned to a BLAZE KING dealer nearest the purchaser at BLAZE KING's expense. IF it is determined by BLAZE KING that there is no defect, or that the defect resulted from causes not within the scope of this warranty, THEN the purchaser must bear the cost of storing the product and of returning the product to the purchaser. For parts of this woodstove or fireplace insert warranted beyond the first year, BLAZE KING will have the same obligations as described in this paragraph, provided, however, that the purchaser shall pay the following percentage of the then-current retail cost of the repair or the replacement, according to the year after purchase in which the defect is brought to the attention of BLAZE KING:

|                          |                    |                          |                    |
|--------------------------|--------------------|--------------------------|--------------------|
| during the 2nd year..... | purchaser pays 20% | during the 3rd year..... | purchaser pays 40% |
| during the 4th year..... | purchaser pays 60% | during the 5th year..... | purchaser pays 80% |

**NOTE: TO VALIDATE THIS WARRANTY YOU MUST COMPLETE AND RETURN THE WARRANTY CARD WITHIN 20 DAYS OF THE DATE OF PURCHASE.**

### MISUSE OF STOVE NULLIFIES WARRANTY:

The above warranty is conditional upon the proper installation and use of the stove according to the manufacturer's directions embodied in the Owner's Installation and Operation Instructions published by BLAZE KING and in compliance with the local building or fire codes in the area where it is installed. The stove should be inspected by the Local Building Inspector or Fire Department prior to beginning use. A copy of the Owner's Installation and Operation Instructions is provided with each unit, or can be obtained by contacting BLAZE KING. READ THE OWNER'S INSTALLATION AND OPERATION INSTRUCTIONS BEFORE INSTALLING OR USING THE STOVE. SAVE THESE INSTRUCTIONS FOR FURTHER MAINTENANCE AND SAFETY PROCEDURES. Alteration of, abuse of, damage to, lack of maintenance of, faulty repair, OR misuse of the stove, VOIDS this warranty. Use of fuel other than natural untreated wood (such as artificial logs, wood exposed to salt water, or coal that may burn at excessively high temperatures or may release fumes that can explode) will VOID this warranty. Burning the stove with the loading door open will also VOID this warranty. Blaze King stoves have been thoroughly tested under extreme conditions, only abuse and over firing may create noticeable warping of components. Over firing of your stove will void all warranties implied or otherwise.

### OTHER LEGAL RIGHTS OF THE PURCHASER:

This warranty gives you specific legal rights, and you may have other rights that vary from state to state or province to province. All parts of this warranty are to be interpreted in accordance with the laws of British Columbia/Canada. If you do not agree to the purchase of the stove on the terms and conditions set out in this warranty, then you must return the stove to the dealer prior to use or installation, and the purchase price will be refunded.



# Definitions

## ALCOVE

For the purposes of this manual, an alcove is defined as A recess or partly enclosed extension connected to, or forming part of, a room. It may be on either an interior or exterior wall. The minimum Dimensions for an alcove in which this stove may be installed are shown on page 22.

## BUILDING CODES AND PERMITS

Most areas require a permit from the city or county Building inspector, or Fire Marshal. Check local building codes before beginning installation. After the installation is completed, it should be checked by your local Fire Marshal or Building Inspector.

## BYPASS

All catalytic wood burning stoves have a bypass device for allowing the smoke from the fire to temporarily bypass, or go around, the catalyst. In Blaze King models, the bypass is located just behind the catalyst. The bypass is a heavy steel plate, hinged inside the stove, and is controlled by the bypass handle on the right side of the stove. When the handle is rotated fully clockwise the bypass is closed, to open the bypass rotate the handle to the counter clockwise stop (see illustrations on page 43) . The bypass handle is shipped in a separate package in the firebox and must be attached to the stove, before using the stove.

**Note:** Your Blaze King features a locking bypass mechanism. By simply pressing down on the by pass handle, you should feel a slight resistance and then a solid stop. By locking the by pass plate each time, you will create a positive seal against the gasket below the by pass plate. This will keep heat loss to a minimum and extend your burn time.

## CATALYTIC COMBUSTOR

This wood heater contains a catalytic combustor, which needs periodic inspection and replacement for proper operation. It is against the law to operate, - this wood heater in a manner inconsistent with operating instructions in this manual, or if the catalytic element is deactivated or removed.

The combustor is a ceramic or stainless steel honeycomb on which is coated a catalyst. The catalyst may be a combination of one or more precious metals, including following: platinum, palladium, rhodium and cerium. The catalyst chemically lowers the combustion temperature of the smoke from a wood fire, thereby allowing more smoke to burn, and both increasing efficiency and lowering emissions. The catalyst is generally operational while the stove thermometer registers in the "Active" zone. If the thermometer does not stay in the Active zone, but falls into the "Inactive" zone for most, of the burn cycle, the thermostat could be set too low or the catalyst may need cleaning or replacement. The catalyst is located in the top of the firebox, just inside the door. See CATALYTIC COMBUSTOR, TESTING, page 36.

## COAL

DO NOT BURN COAL IN THIS STOVE. Evidence of coal burning automatically voids all warranties.

## CHIMNEY

One or more passageways, vertical or nearly so, for sending flue gases (smoke) to the outside atmosphere.

Stoves must be vented ONLY to the outside, never to other rooms or buildings.

Special methods are required when passing through a wall or ceiling. See chimney manufacturers instructions and local building codes. Two types, of chimneys are acceptable for use with these stoves:

1. A listed factory built chimney suitable for use with solid fuels and conforming to, ULC629 in Canada or UL-103HT in the USA.
2. Masonry Chimney: A field-constructed, code-approved, chimney of solid masonry units, bricks, stones, listed masonry chimney units or reinforced Portland cement concrete, with at least 5/8" fire clay lining joined with refractory cement or other listed lining system suitable for use with wood stoves. Before connecting to an existing masonry chimney, have it inspected by a certified chimney sweep.

**NEVER VENT THE STOVE INTO A CLASS "B" GAS VENT CHIMNEY. NEVER USE A CHIMNEY CONNECTOR OR CHIMNEY FLUE SMALLER THAN THE STOVE EXHAUST, UNLESS APPROVED BY YOUR LOCAL INSPECTOR.**

Avoid a home fire. Maintain the designated clearance distance to combustibles. Insulation must not touch the chimney. There must be the designated air space clearance around the chimney. This air space around a chimney is necessary to allow natural heat removal from the area. Insulation in this space will cause a heat buildup which may ignite wood framing.

**DO NOT CONNECT THIS UNIT TO A CHIMNEY FLUE SERVING ANOTHER APPLIANCE.**

Generally, the taller the chimney, the more dependable the draft. The chimney should be kept warm to enhance the draft. This will also protect against creosote accumulation caused by condensation of water vapor and smoke. A build-up of creosote can reduce the draft and will become a potential fire hazard. See CREOSOTE, page 9.

A chimney should extend at least three feet above a flat roof, or at least two feet above any part of the roof within 10 feet.

Chimney tops should NEVER be near trees or other tall objects that might cause down-drafts.

## CHIMNEY CONNECTOR

Also known as stovepipe. Connects a fuel-burning appliance to a chimney. A chimney connector shall not pass through an attic or roof space, closet or similar concealed space, or a floor, ceiling, wall or partition of combustible construction. The chimney connector should be 8" in diameter for KE1107 and 6" for PE1006, of not less than 24 gauge black/blue steel, and of either single or double wall construction. The stove collar accepts only 8" pipe for KE1107 and 6" pipe for PE1006. The small end of the pipe fits into the collar to enable any distillates which may form in the chimney to fall back into the stove, see page 17.

(Prefabricated chimney is not normally required as a chimney connector for residential installations).

A chimney connector can also be used horizontally as a connection between the stove and masonry chimneys or prefabricated chimneys, provided that the horizontal length does not exceed three (3) feet AND THE PIPE SLOPES UPWARD TOWARD THE CHIMNEY AT A RATE OF 1/4" PER FOOT. This slope in the horizontal connection is required to facilitate the drainage of creosote deposits back into the stove. The chimney connector is to be attached to the smoke collar with two screws, and at least two screws are required at each joint. Horizontal sections of chimney connector must be AT LEAST 18" from the ceiling.

# Definitions

## **CLOSE CLEARANCE**

Installing a stove closer to combustibles by using side or rear shields, fan kits or double wall close clearance connectors. Close clearance connectors must be from the same manufacturer as the listed prefabricated chimney.

## **COMBUSTIBLE MATERIAL**

Material made of or surfaced with wood, compressed paper, plant fibers, plastics, or other materials that will ignite and burn, whether flame proof or not, or whether plastered or un-plastered.

## **COMBUSTION AIR INTAKE**

Located on the back of the stove, on the centerline. Combustion air is drawn into this opening, through the thermostat and into the firebox. In tight contemporary homes, using outside combustion air may be desirable. Outside combustion air is required in all mobile home installations.

If national or local codes require it, an OUTSIDE AIR KIT is available from the dealer who sold you the stove.

The outside air inlet hose is a flexible tube which can be bent to take outside air in through the wall or up through the floor. The flexible tube will allow some adjustment over or around the floor joists or plumbing. **DO NOT CHANGE THE STRUCTURAL INTEGRITY OF THE FLOOR.** This air hose must be kept open at all times to provide outside air for combustion. See page 31.

## **CREOSOTE - FORMATION AND NEED FOR REMOVAL**

When wood is burned slowly, it produces tar and other organic vapors which combine with expelled moisture to form creosote. The creosote vapors condense in the relatively cool chimney flue of a slow-burning fire. As a result, creosote residue accumulates on the flue lining. When ignited, this creosote makes an extremely hot fire.

**PREVENT CREOSOTE FIRES:** Inspect Chimney Connector and Chimney TWICE monthly and clean if necessary. If a chimney fire starts, close the loading door and turn the thermostat to the lowest setting. Call the fire department immediately.

The basic design of this catalyst equipped stove will reduce creosote accumulation to a very low level. However, the frequency of start-up operations and the temperature at which the stove is operated on a regular basis can affect that accumulation. The inspection frequency noted above is still a vital step in the safe operation of any wood burning system.

## **DOOR, LOADING**

The door on the front of the stove, with viewing glass installed. This door must be closed and latched tightly whenever the fire is burning. When cleaning the stove, wait 1/2 hour after the fire is out or until the stove is sufficiently cooled before opening the door.

## **DRAFT**

This appliance may not operate properly if the draft is below .02" of water as measured using a water manometer. Draft below .02" will cause excessive smoke spillage, incomplete combustion and fire startup problems. Low draft may sometimes be improved by making a chimney taller, and the use of double wall stove pipe. The use of two 45° degree elbows in place of 90° elbows is recommended. Exterior chimneys may be too cold to achieve proper draft with these units. If an exterior masonry chimney is being used it should be lined with a listed stainless steel liner. An external factory built chimney should be enclosed in an insulated chase.

## **FANS (Optional on KE1107 and PE1006, Standard on KEJ1107 and PEJ1006)**

Two variable speed axial fans (105 CFM each). The fans circulate room air across the firebox and back into the home. The fan speed should be adjusted to match the heat output of the stove. The fans are also controlled by a temperature sensitive switch. The fans will not start up until the stove reaches operating temperature.

## **FAN SPEED CONTROL**

Located on the (optional) Fan Assembly controls the fan speed. When stove is burning on low, set fans to low. When stove is burning on high, set fans to high. Adjust fan speed to match, as much as possible, the burn rate of the stove.

## **FIREBOX, STOVE**

Steel, lined with firebrick. The recommended length of log to be used in this firebox is 16" for PE1006 and 18" for KE1107.

## **FIREPLACE**

This stove must not be connected to any type of fireplace.

## **FLAME SHIELD**

The flame shield is a 3/16" stainless steel plate, punched with many 3/8" holes. If the flame shield is shipped in the firebox or has fallen off during shipping then it must be installed before the first fire. Hold it in the firebox with the triangular wings facing away. Lift it between the loading door and the catalyst, and rest the bottom of the plate on the two holders that protrude below the catalyst. The flame shield should rest at an angle (about 45 degrees) with its bottom near the combustor, and its top near the stove front. Do not operate the stove without the flame shield in position.

## **FLAMMABLE LIQUIDS**

NEVER use gasoline, gasoline-type lantern fuel, kerosene, charcoal lighter fluid or similar liquids to start or "freshen up" a fire in this stove. Keep all such liquids well away from the stove while it is in use.

## **FLOOR PROTECTOR**

Noncombustible surfacing applied to the floor area underneath and extending in front, to the sides and to the rear of a heat producing appliance. Floor protector sizes are shown on page 17.

## **FLUE**

The general term for a passage through which flue gases (smoke) pass from the combustion chamber to the outside air.

## **FUEL**

THIS STOVE IS FOR USE WITH SOLID WOOD FUEL ONLY.

**Do not burn trash, paper, pine branches or artificial fire logs. Such abuse may void the warranty.**

# Definitions

## CAUTION

**DO NOT USE GASOLINE, GASOLINE-TYPE LANTERN FUEL, KEROSENE, CHARCOAL LIGHTER FLUID OR SIMILAR LIQUIDS TO START OR "FRESHEN UP" A FIRE IN THIS APPLIANCE. KEEP THESE FLAMMABLE LIQUIDS WELL AWAY FROM THIS APPLIANCE WHILE IT IS IN USE.**

### HEARTH

The bricked floor area within the fire chamber of a fireplace or fireplace stove. The bottom of the firebox. Build the fire directly on the Hearth.

### ICE - FORMATION AND PREVENTION

Most of what you see coming from the chimney of a properly operating catalytic stove is water vapor. In extremely cold weather - and with some exterior chimneys - this vapor may freeze in the chimney, to the point of actually blocking the chimney and extinguishing the fire. In such weather, occasionally burn the stove for 4 or 5 minutes with the bypass open and the thermostat set at maximum to melt any possible ice buildup. **DO NOT BURN THE STOVE WITH THE DOORS OPEN.**

### INSPECTIONS

The stove should be inspected periodically for missing firebricks, corroded metal or deterioration of parts. If anything appears unsafe, contact your stove dealer for advice. Do not operate stove until that condition is corrected. The chimney and chimney connector should be inspected at the beginning of each burning season and twice monthly during the winter to determine if a creosote buildup had occurred. If creosote has accumulated it should be removed to reduce the risk of a chimney fire. See CREOSOTE, page 12. Chimney caps occasionally will be plugged. See, Maintenance, page 38.

### LISTED

Meeting Underwriter's Laboratories, Inc. standards and specifications when installed properly, and inspected.

### MOBILE HOME

A residence mounted on wheels, or capable of having wheels installed for moving to another location. Typically, a residence with a steel frame supporting the structure and providing an axle(s) for the installation of wheels to move it into the location and out again. Frequently referred to as 'Manufactured Homes' to differentiate between travel trailers and more permanent residences. These appliances are tested and listed for mobile home installations utilizing a prefabricated chimney system, straight up from the stovetop, through the ceiling and roof. Under no conditions are elbows and/or Tees permitted in Mobile homes. For use in mobile homes, this appliance is only listed to be connected to a listed factory built chimney suitable for use with solid fuels and conforming to, ULC629 in Canada or UL-103HT in the USA. Use of any other venting system or components in mobile homes voids the stove listing and the warranty. Contact local building or fire officials for information regarding local codes. The structural integrity of the mobile home floor, wall and ceiling/roof must be maintained.

**WARNING: DO NOT INSTALL IN A SLEEPING ROOM.**

### OUTSIDE AIR KIT (Optional)

An optional kit which draws outside air through a duct. The stove uses the air for combustion. The Outside Air Kit is required in mobile home installations, and occasionally required in residential installations. Check local codes before installing your stove.

### THERMOMETER

The probe of the Blaze King catalyst thermometer rests behind the catalyst. The thermometer gives an indication of the temperature of the gasses after the catalyst. Due to the way it is made, the thermometer has a 4 - 8 minute lag time. The thermometer should be periodically cleaned. Lift it from the stove (be careful, it *may* be hot) and wipe the probe clean. At room temperature (out of the stove) the thermometer indicator generally points to the bottom of the "Inactive" zone. It may, over time, change slightly. Adjust it by loosening the bolt above the dial, and turning the dial face. Be sure the bolt is retightened before placing back on stove. See THERMOMETER, page 38.

**Note:** If your Blaze King is equipped with optional fans, turn off fans and wait 10 minutes prior to reading catalytic thermometer indicator. Air movement across the top of the stove may provide false reading.

### THERMOSTAT

The thermostat, sometimes referred to as the Combustion Air Control, is mounted on the back of the stove, near the top. It incorporates a bimetallic coil which responds to the naturally uneven cycles of the burning wood. This automatic compensation gives you even, comfortable heat. These Blaze King stoves burn cleanest when the thermostat is set and left unchanged. Frequent adjustments are unneeded and reduce efficiency and clean burn.

### THIMBLE

A listed, manufactured product installed in combustible walls and ceilings through which the chimney passes to the outside. It is intended to prevent the combustible materials from igniting.

### TIE DOWN SCREWS

These lag screws are used to secure the stove to the residence floor. Their use is required in mobile home installations.

# Safety

## SAFETY WARNING

IF THIS STOVE IS NOT PROPERLY INSTALLED, A HOUSE FIRE MAY RESULT. FOR YOUR SAFETY, FOLLOW THE INSTALLATION DIRECTIONS. CONTACT LOCAL BUILDING OR FIRE OFFICIALS ABOUT RESTRICTIONS AND INSTALLATION REQUIREMENTS IN YOUR AREA.

PLEASE READ THIS ENTIRE MANUAL BEFORE YOU INSTALL AND USE YOUR NEW STOVE. FAILURE TO FOLLOW INSTRUCTIONS MAY RESULT IN PROPERTY DAMAGE, BODILY INJURY OR DEATH.

## CAUTIONS:

1. **NEVER** vent the stove to other rooms of the building. Stove must be vented **ONLY** to the outside.
2. **NEVER** use a chimney or chimney connector smaller than the stove exhaust, unless approved by your local inspector.
3. **NEVER** vent the stove into a "Class B" gas vent chimney.
4. **NEVER** burn materials other than natural wood. **DO NOT** burn trash, garbage, artificial or paper logs, gift wrappings, coal, lighter fluids, chemical cleaners, chemical starters, treated or painted wood, driftwood or foil-backed paper such as gum wrappers or cigarette packages. Burn natural wood only.
5. **NEVER** intentionally start a chimney fire to clean the flue.
6. **NEVER** burn the stove so hot that the stove or chimney connector begins to glow.
7. **NEVER** burn the stove with the loading door open.

## CHIMNEY FIRE

In the event of a fire in the chimney:

- A. Adjust the thermostat to its lowest setting.
- B. Check that the Loading Door is tightly closed.
- C. Get everyone out of the house.
- D. Call the Fire Department immediately.
- E. Check the roof for burning embers that might cause a fire.

Your family should have a prearranged plan so that each person will know what to do and will act immediately if such an emergency arises.

After the fire is out, have your chimney inspected by a Building Inspector or certified chimney sweep. Any damaged chimney components should be replaced before the stove is used again. A masonry chimney that is damaged should be repaired or rebuilt. Contact your Fire Department for further advice.

## SMOKE DETECTORS

Install at least one smoke detector on each floor of your home to ensure your safety. It should be located away from the woodstove and close to the sleeping areas. Locating a smoke detector too close to a woodstove can cause the smoke detector alarm to sound if a puff of smoke is emitted while the woodstove door is open during reloading. Follow the smoke detector manufacturers placement, installation, and maintenance instructions. Your local Fire Department may provide assistance in selecting smoke detectors, or in the U.S.A. contact the Consumer Product Safety Commission, Washington, D.C. 20207.

## FIRE EXTINGUISHERS

Every home should have at least one fire extinguisher. An approved "Class A-B-C" extinguisher should be mounted on the wall, near an exit and close to the stove -- but not so close that accessibility to the extinguisher could be blocked by a fire. Your local fire department can advise you concerning the most appropriate location.

## BUILDING AND FIRE CODES, PERMITS, AND INSPECTIONS

The installation of this woodstove must comply with your local building and fire codes. Always contact your local Building Inspector and/or Fire Department before beginning the installation process. If required, obtain a permit before installation and have the completed installation inspected. Remember that noncompliance with building and/or fire codes may jeopardize your homeowner's insurance.

## CHILDREN

Do not allow children to play near the stove or with the controls. Severe burns may be inflicted by touching the door or door glass, the front, sides or top of the stove. Train children to stay away from the stove and never leave children unattended in the room when the stove is in operation.

## CHIMNEYS

See "Definitions," page 8. The use of makeshift chimney installation is not allowed'.

Before connecting any wood-burning unit to an existing chimney, inspect the chimney to be sure it is in good condition. There must be no cracks or holes. Often it is impossible to see these from the outside. A certified chimney sweep should inspect your chimney and give you an accurate assessment of its condition.

# Safety

The cross-sectional area must not be less than that of the flue collar unless approved by your local inspector. Relining or rebuilding *may* be necessary to make a Masonry Chimney safe. A code-approved chimney with a flue liner is most important for safe, satisfactory operation of any wood heating system. Inspect the Chimney and Chimney Connector (if installed) at least twice each month during the heating season. Any leak must be repaired. A chimney fire or deterioration can enlarge the hole. This will admit more air and cause exhaust gases to condense and form creosote. Patches of creosote in your chimney indicate that such leaks are present.

**CAUTION: Never look directly up a chimney. The use of a mirror, flashlight and goggles is recommended to prevent eye injury due to falling debris.**

If a significant amount of creosote has accumulated, it should be removed to reduce the risk of a chimney fire. (Refer to Creosote - Formation and Need for Removal, below.)

## CLEARANCES TO COMBUSTIBLE MATERIALS

For a safe installation, proper clearances to combustible materials must be observed; see page 22-27. Failure to follow these guidelines voids the certification and warranty, is illegal, and can result in a fire causing property damage, injury, or death.

Keep combustible (burnable) materials at least as far away from the woodstove as the table on page 23 indicate. Combustible materials include items such as plasterboard or wood-paneled walls, furniture, wooden mantels, bookshelves, carpets and drapes. Firewood should not be stored within the specified clearances. AVOID FIRE. Maintain the designated clearance distance to combustibles. Insulation must not touch the chimney. There must be the designated air space around the chimney. This air space around a chimney is necessary to allow natural heat removal from the area. Insulation in this space will cause a heat buildup which may ignite wood framing.

## CREOSOTE -- FORMATION AND NEED FOR REMOVAL

When in good condition and operated properly, your Blaze King catalyst-equipped stove is a clean-burning stove. So if significant creosote buildup occurs, re-examine your fire-building and burning procedures. Reread pages 32 through 38 of this owner's manual. Most instances of creosote buildup in the chimneys of catalytic woodstoves are due to operator error. If you still have questions, consult your dealer or contact the Customer Service department at Blaze King.

## INSPECTION:

Inspect your chimney and chimney connector at least twice each month during the heating season. Patches of creosote in your chimney or chimney connector indicate a possible air leak. Any leak must be repaired. A chimney fire or deterioration can enlarge the leak. This will admit more air and cause exhaust gases to condense and form additional creosote.

If a significant amount of creosote has accumulated, it must be removed to reduce the risk of a chimney fire.

## CLEANING:

NEVER intentionally start a chimney fire to clean the flue. DO NOT clean the chimney while it is still connected to the stove. Remove the bottom section of pipe and attach a bag to the chimney to catch any creosote removed.

Hire a chimney sweep or clean the chimney yourself with a tight-fitting chimney brush. Makeshift equipment--hoses, tire chains, etc.. can damage the flue and will probably do an unsatisfactory cleaning job. After cleaning the chimney, clean inside the top of the stove. Scrape, if needed, and vacuum all creosote and fly ash from around the bypass door.

## FUEL

THIS WOODSTOVE IS FOR THE USE WITH SOLID WOOD FUEL ONLY. NEVER USE GASOLINE, GASOLINE-TYPE LANTERN FUEL, KEROSENE, CHARCOAL LIGHTER FLUID OR SIMILAR LIQUIDS TO START OR 'FRESHEN UP' A FIRE IN THIS HEATER. KEEP ALL SUCH LIQUIDS WELL AWAY FROM THE HEATER WHILE IT IS IN USE.

Do not burn materials soaked in flammable liquids, trash, garbage, plastics, gift wrappings, coal, charcoal, naphtha, engine oil, chemical cleaners, chemical fire starters, treated or painted wood, saltwater driftwood, railroad ties, plywood, particle board. Do not burn sawdust, wood shavings or chips in this woodstove. Using saltwater driftwood damages the firebox.

Any indication of saltwater driftwood use will void the manufacturers warranty.

When selecting wood for a Blaze King Catalytic Stove, it is preferable that you use seasoned wood. Dry, seasoned wood will burn cleaner and produce less creosote.

The wood for these stoves should be cut to lengths that are not more than 16" long for PE1006 and 18" KE1107.

**CAUTION: Do not store wood fuel within the space heater installation clearances for even a short period of time.**

# Safety

## ELECTRICAL POWER

If the optional fans are installed, connect this unit to a properly grounded, 110-volt electrical outlet. Do not route the power in front of, or under, the stove.

## DISPOSAL OF ASHES

Ashes should be placed in a metal container with a tight fitting lid. The closed container of ashes should be placed on a noncombustible floor or on the ground, well away from all combustible materials, pending final disposal. If the ashes are disposed of by burial in soil or otherwise locally dispersed, they should be retained in the closed container until all cinders have thoroughly cooled.

Do not store other waste in the ash container. Ashes should never be placed in wooden or plastic containers, or in paper or plastic bags, no matter how long the fire has been out. Coals have been known to stay hot for several days when embedded in ashes

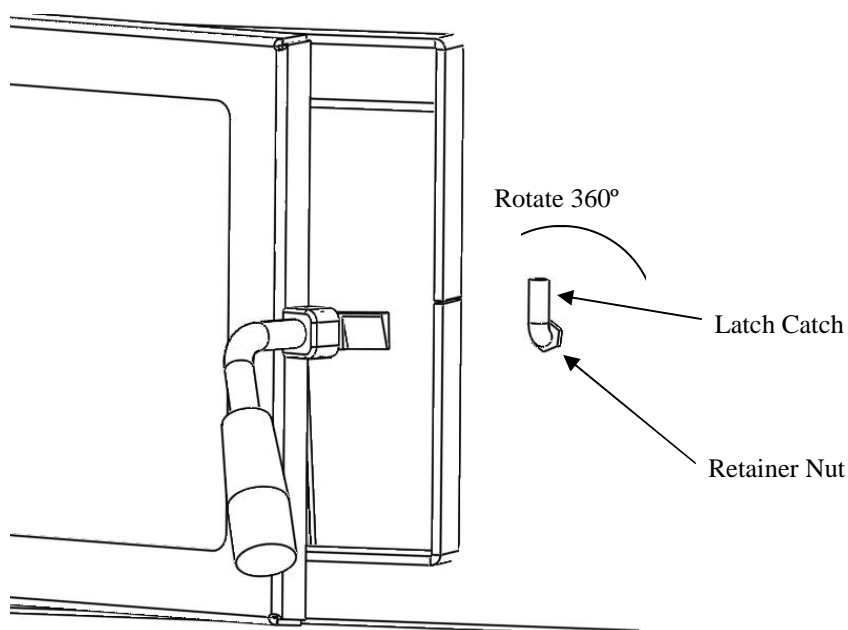
**WARNING**  
**REMOVE ASHES ONLY WHEN THEY ARE COLD. NEVER STORE HOT ASHES IN A GARAGE OR BASEMENT. HOT ASHES WILL GENERATE CARBON MONOXIDE AND/OR FLAMMABLE GASES. THESE GASES MAY CAUSE SUFFOCATION.**

## LOADING DOOR

Do not operate your stove with the loading door open. This stove is not designed or intended to be operated with the loading door open. Do not leave your stove unattended when the loading door is not tightly closed, such as when starting a fire. Leaving the loading door open AFTER the fire is well started can cause overheating of the stove. Such overheating can cause the stove to warp. Check the loading door gasket for deterioration at least twice each heating season. Inspect the gasket for physical deterioration missing sections or obvious leakage. To check the gasket further, wait for your stove to cool, insert a piece of paper into the door opening and close and latch the door. Obvious resistance should be felt when pulling the paper out. Repeat this check several times around the perimeter of the door.

To tighten the gasket, use a 9/16" wrench to loosen retainer nut and rotate latch catch 360 degrees clockwise (see figure below). Secure retainer nut and repeat paper test.

**DO NOT FORCE THE LATCH CATCH TO TURN.** Use penetrating oil if necessary to make turning easier



# Specifications

| <u>Specification</u>   | <u>KE / KEJ 1107</u> | <u>PE / PEJ 1006</u> |
|--|----------------------|----------------------|
| Minimum heat output  | 8,750 Btu/hr         | 6,400 Btu/hr         |
| Maximum heat output  | 47,000 Btu/hr        | 40,000 Btu/hr        |
| Overall efficiency, weighted average Method, CSA-B415                          | 82.5%                | 82.5%                |
| Wood capacity (approximate)  |                      |                      |
| White oak  | 90 lbs.              | 60 lbs.              |
| Fir  | 60 lbs.              | 40 lbs.              |
| Recommended wood length  | 18 inches            | 16 inches            |
| Total weight, with firebrick   | 410 lbs.             | 350 lbs.             |
| Width, without removable bypass handle   | 30.00 inches         | 27.00 inches         |
| Depth, with optional fan kit   | 30.17 inches         | 29.17 inches         |
| Height (including Flue Collar)   |                      |                      |
| -Classic   | 34.25 inches         | 29.25 inches         |
| - Parlor   | 37.50 inches         | 34.05 inches         |
| - Ultra  | 39.00 inches         | 35.10 inches         |
| Door opening width   | 17.69 inches         | 16.40 inches         |
| Door opening height  | 9.77 inches          | 8.20 inches          |
| Flue size, diameter  | 8 inches             | 6 inches             |
| Low Burn Time (Average) up-to  | 40 Hours             | 20 Hours             |
| Combustion Chamber Cu. Ft.   | 4.32                 | 2.85                 |
| Emissions (Weighted Average EPA)   | 1.76G                | 2.42G                |
| Overall Efficiency   | 82.5%                | 82.5%                |
| Optional fans, two variable speed  | 105 CFM each         |                      |
| Door glass Corning, Pyroceram II, Clear View Plus (TM)                         |                      |                      |
| KEJ, 5mm x 16.43 x 10.43 inches  |                      |                      |
| PEJ, 5mm x 15.8 x 9.875 inches   |                      |                      |
| Minimum chimney cross-sectional area (unless approved by your local inspector) |                      |                      |
| KEJ 8" flue 50 sq. inches  |                      |                      |
| PEJ 6" flue 28.25 sq. inches   |                      |                      |

### The Facts On BTU's:

There are only two rating methods that mean something to you the consumer. The first is the Btu output that is achieved during EPA testing. This testing is quite complicated and costly milled woods are burned. This is a standard for all manufacturer testing and is not intended to provide consumers with a model for how a stove will burn in their home. The second method that counts is what Blaze King refers to as the "Real World" method. These btu's are achieved during in house testing using the same thing a consumer burns, split, dry, cordwood. In our tests, we use fir. The "Real World" btu's listed are what the average consumer can expect to achieve, with slight variations depending upon geographical location, type of wood, elevation and the amount of fuel added. Higher btu's are possible. If you were to stand in front of your stove and frequently add fuel, burn the unit on high and have optimal conditions, the PEJ1006 could produce as high as 87,500 btu's and the KEJ1107 could exceed 90,000 btu's! However, maximum btu's would only be achievable at certain "peak" times during the burn. Blaze King does not wish to mislead you so we give you all the facts.

| <u>Btu Ratings</u>                   | <u>PE / PEJ 1006</u> | <u>KE / KEJ 1007</u> |
|--------------------------------------|----------------------|----------------------|
| Average EPA Test Fuel (Low Burn)     | 11,989 Btu/hr        | 8,600 Btu/hr         |
| Average EPA Test Fuel (High Burn)    | 35,550 Btu/hr        | 37,800 Btu/hr        |
| Average Real World Btu's (Low Burn)  | 6,400 Btu/hr         | 8,400 Btu/hr         |
| Average Real World Btu's (High Burn) | 40,000 Btu/hr        | 47,000 Btu/hr        |

Tested and listed to U.L. 1482 by Warnock Hersey International, 8431 Murphy Drive, Middleton, WI 53562  
608-836-4400

Certified to comply with July 1990 particulate emissions standards of the U.S. Environmental Protection Agency.  
KEJ-1107, certificate number 546.  
PEJ-1006, certificate number 278

# Preparation And Assembly

## WARNING

**IMPROPER ASSEMBLY AND/OR INSTALLATION OF YOUR BLAZE KING WOODSTOVE OR FAILURE TO OPERATE IT ACCORDING TO THE GUIDELINES DETAILED IN THESE INSTRUCTIONS, WILL VOID THE STOVE WARRANTY, CAN CAUSE A HOUSE OR CHIMNEY FIRE, AND MAY ENDANGER YOUR FAMILY. FOR YOUR SAFETY, FOLLOW THE ASSEMBLY AND INSTALLATION INSTRUCTIONS CAREFULLY. CONTACT LOCAL BUILDING OR FIRE OFFICIALS ABOUT RESTRICTIONS AND INSTALLATION INSPECTION IN YOUR AREA. PLEASE READ THIS ENTIRE MANUAL BEFORE YOU INSTALL AND USE YOUR NEW STOVE.**

These Blaze King woodstoves are Listed by Warnock Hersey ONLY if: they are connected to a code-approved masonry chimney with a flue liner, or a listed factory built chimney suitable for use with solid fuels and conforming to, ULC629 in Canada or UL-103HT in the USA. and minimum clearances to combustible (burnable) materials are observed. See CHIMNEY and CHIMNEY CONNECTOR, pages 8 and 9, and Table 1 on page 23 for minimum clearances.

**DO NOT CONNECT THIS UNIT TO A CHIMNEY FLUE SERVING ANOTHER APPLIANCE.**

## TOOLS NEEDED FOR INSTALLATION

If you are planning to install this stove yourself, you will need the tools listed below. Consult the chimney and chimney connector manufacturer's installation instructions for **tools** needed for chimney installation.

- a- 1/4" Wrench, Nut driver, or Socket with Handle.
- b- Medium Flat Blade Screwdriver, Phillips Screwdriver and Square Drive Screwdriver
- c- Tape Measure.
- d- Carpenter's Level.
- e- See OPTIONS section for tools needed.

## PLANNING FOR YOUR STOVE PLACEMENT

As you plan your installation, consider the following:

- a- Stove should be placed as central in the home as possible. Consider safety, convenience, traffic flow, and the fact that the stove will need chimney and chimney connector.
- b- MINIMUM CLEARANCES SHOWN ON PAGE 22 ARE TO PREVENT WALLS AND CEILINGS FROM CATCHING ON FIRE.
- c- The dimensions and position of the Floor Protector. See page 22 .
- d- The type of chimney system to be used.
- e- Electrical Power (Optional) The stove can be equipped with a fan assembly with a seven-foot electrical cord. Do not route the cord in front of the stove.

## REDUCED WALL CLEARANCE

The stove and chimney connector may be placed closer to the wall than shown on pages 22-28 if the wall is properly protected. Clearances to combustibles may be reduced by only using proper approved clearance reduction shields. In the USA refer to **NFPA 211** and in Canada refer to **CSA B365-01 section 7.2.4**. All reduced clearance installations **must** be approved by the authority having jurisdiction.

## INSPECT YOUR CHIMNEY

Before connecting any wood-burning unit to an existing chimney, inspect the chimney to be sure that it is in good condition. There must be no cracks or holes. The cross-sectional area must not be less than that of the flue collar (unless approved by your local inspector). A proper chimney is crucial for safe, satisfactory operation of any wood heating system. Relining or rebuilding may be necessary to make the chimney safe, efficient, and in conformity with local codes.

Masonry Chimneys that have a very large cross-section , particularly exterior chimneys, may experience poor draft and may require relining to reduce the cross-section-and provide a proper draft. This is also an ideal time to clean the existing chimney. For peak efficiency, a clean chimney flue is essential. A qualified professional chimney sweep can perform both inspection and cleaning. If you choose to clean your own chimney, use the proper tools. Homemade cleaners, may damage your chimney.

Be sure the Ash Clean-Out Door for the masonry chimney is closed and sealed tightly. This door may be in the wall below the chimney, in the room below the chimney or outside near the ground level of the chimney. This is frequently overlooked, and can cause severe drafting and creosote problems in masonry chimney installations. The chimney **MUST** extend above the roof at least three feet or two feet above any area of the roof within ten feet of the termination of the chimney.



# Preparation and Assembly

## CHIMNEY HEIGHT AFFECTS DRAFT

Tall chimneys usually provide a strong, dependable draft. The chimney should be kept warm to enhance the draft. This will also reduce creosote accumulation caused by smoke and condensation of water vapor. A buildup of creosote can reduce the draft and will become a potential fire hazard. Chimney tops should NEVER be near trees or other tall objects that might cause downdrafts. In new homes, or homes that have been weatherized and are very air-tight, exhaust fans, such as those installed in kitchens and bathrooms, can create a negative pressure in the room and a resulting downdraft in a chimney, when the fans are operating. Smoke may be drawn into the room, particularly when the loading door is open while the stove is being loaded. If this problem arises, open a window while the exhaust fan is being used or do not operate the exhaust fan while reloading the stove. If make-up air (with outside air kit) is NOT supplied, the negative pressure *may* also draw gases from a gas furnace.

If you have a Forced-air heating system, you can use the furnace fan to circulate air through the house, but DO NOT connect any ducting between the stove and the heating system ducts or any other air-distribution ducts.

## STOVE ASSEMBLY

Remove all items packed in the firebox.

IF YOU HAVE NOT ALREADY DONE SO, PLEASE TAKE A FEW MINUTES TO COMPLETE THE WARRANTY CARD FOUND IN THE FIREBOX AND MAIL IT TODAY.

## PRODUCT INSPECTION

BLAZE KING Stoves are known for their quality materials and construction. However, mistakes occasionally occur. Inspect all parts for damage due to shipping and to be sure that all needed parts are enclosed. If you discover a part is missing or damaged, contact your dealer immediately for replacement or repair. Refer to the part number listed on page 42 and the model and serial numbers of your stove (see the tag on the back of the stove).

## COMBUSTOR ASSEMBLY, INSTALLATION

See page 29 for proper parts names. This stove is generally shipped from the factory with the combustor installed. If the combustor is not installed, follow the instructions on page 37 under Catalytic Combustor, Replacement, beginning with Step 6.

## FLAME SHIELD, INSTALLATION

The flame shield is a 3/16" stainless steel plate, punched with many 3/8" holes. If the flame shield is shipped in the firebox or has fallen off during shipping then it must be installed before the first fire. Hold it in the firebox with the triangular wings facing away. Lift it between the loading door and the catalyst, and rest the bottom of the plate on the two pins that protrude below the catalyst. The flame shield should rest at an angle (about 45 degrees) with its bottom near the combustor, and its top near the stove front.

## OPTIONAL ACCESSORIES

See page 29.

## REPLACEMENT PARTS

See page 42.

# Installation – General Instructions

## FLOOR PROTECTOR

The stove must be placed on a floor protector.

A floor protector is a noncombustible surfacing applied to the floor area underneath and extending in front, to the sides and to the rear of a heat producing appliance.

To provide the proper clearances, the floor protector must extend

16" (18" for Canada) in front of the loading door opening.

8" from each side of the **loading door** opening.

KEJ floor protector must be no smaller than 34" x 45".

PEJ floor protector must be no smaller than 32" x 44".

The floor protector must extend to the wall under a wall exit installation and must extend 2" beyond each side of the horizontal section of chimney connector.

**Note:** In Canada, check with local jurisdiction, a floor protection with a minimum of 43" x 55" for the PE and 46" x 56" for the KE might be required. (18" Front / 8" Rear / 8" Side)

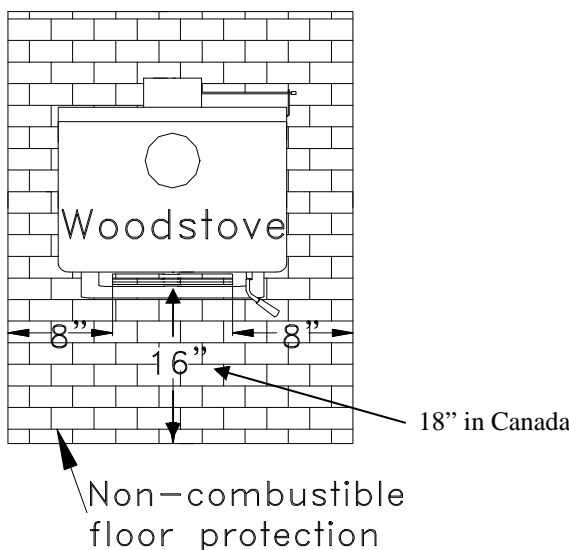


Fig. 7 Floor Protection Dimensions

## WARNING

**FAILURE TO PROVIDE ADEQUATE FLOOR PROTECTION CAN CAUSE A HOUSE FIRE. SUCH A FIRE CAN RESULT IN DAMAGE TO PROPERTY AND SERIOUS INJURY OR DEATH.**

## VENTING SYSTEMS

The venting system consists of a chimney connector and a chimney. These get extremely hot during use. Temperatures inside the chimney may exceed 2000 degrees in the event of a creosote fire. To protect against the possibility of a house fire, the chimney connector and chimney must be properly installed and maintained. A listed thimble must be used when a connection is made through a combustible wall to a chimney. A chimney support package must be used when a connection is made through the ceiling to a listed prefabricated chimney. These accessories are absolutely necessary to provide safe clearances to combustible wall and ceiling material.

This stove may be connector to a lined masonry chimney or a listed factory built chimney suitable for use with solid fuels and conforming to, ULC629 in Canada or UL-103HT in the USA. Do not connect it to a chimney serving another appliance. To do so will affect the safe operation of both appliances, and will void the stove warranty.

## CHIMNEY CONNECTOR

The chimney connector must be 8" diameter for KE1107 or 6" diameter for PE1006, 24/26 MSG Back/Blue steel. Do not use aluminum or galvanized steel. They cannot properly withstand the extreme temperatures of a wood fire. Do not use chimney connector pipe as a chimney. You must connect your stove to a chimney comparable to those illustrated in this manual.

# Installation – General Instructions

Chimney connector sections must be attached to the stove and to each other with the crimped end toward the stove (Fig. 8). This allows creosote to run into the stove and not onto the outside of the pipe. All joints should be secured with three metal screws. Otherwise, in the event of a creosote fire, the connector may vibrate apart.

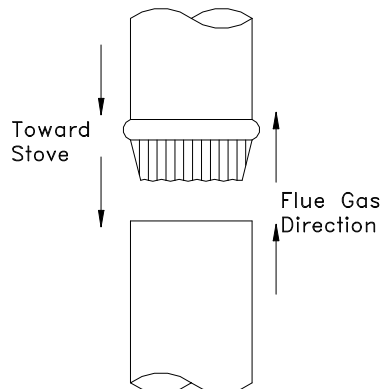


Fig. 8 Flue Gas Direction

For proper operation the chimney connector should be as short as possible. Horizontal lengths of chimney connector should have an upward slope from the stove of 1/4 inch per foot. Maintain 13 inches clearance between the chimney connector and the ceiling.

## CONNECTION TO A MASONRY CHIMNEY

Should the stove be connected to a masonry chimney, the chimney should be examined for cracks, loose mortar, other signs of deterioration, and blockage. The stove should not be installed until it is determined that the chimney is safe for use. Since an oversized flue contributes to the accumulation of creosote, the size of the flue should be checked to determine that it is not too large for the stove. For this stove it is recommended that the flue size should not exceed the overall area of an 8" flue (50 square inches) for KE1107 or 6" flue (28.25 square inches) for PE1006. The chimney should also be checked to assure it meets the minimum standards of the National Fire Protection Association (NFPA) Standard 211. Following is a list of the more critical minimum requirements for a properly constructed chimney.

1. The masonry wall of the chimney, if brick or modular block, must be a minimum of 4 inches nominal thickness. A mountain or rubble stone wall must be at least 12 inches thick.
2. The chimney must have a fire clay flue liner (or equivalent) with a minimum thickness of 5/8 inch and must be installed with refractory mortar. There must be at least 1/2-inch air space between the flue liner and the chimney wall

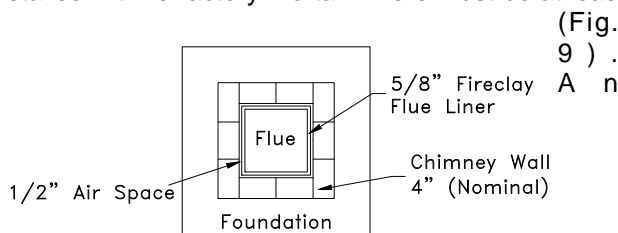


Fig. 9 Masonry Chimney Construction

equivalent liner might be a listed chimney liner system or other approved material.

3. A chimney inside the house must have at least 2 inches of clearance to the combustible structure. A chimney outside the house must have at least one-inch clearance to the combustible structure. Fire stops must be installed at the spaces where the chimney passes through floors and/or ceiling (Fig. 10).

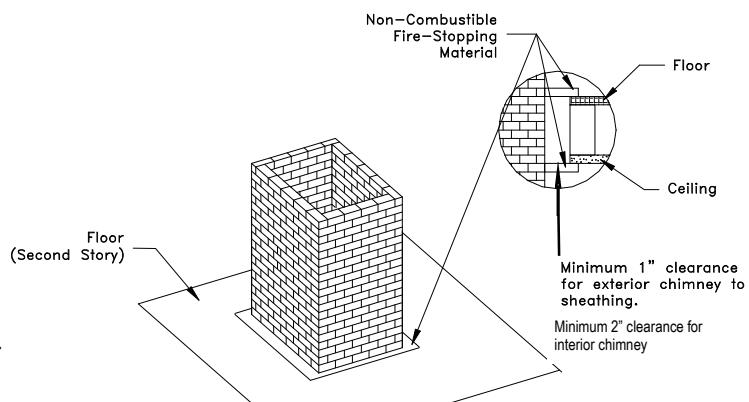


Fig. 10 Fire Stopping

Remember that insulation must not contact the chimney. There must be air space around the chimney. Insulation must be 2 inches or more from the chimney (Fig. 11).

# Installation – General Instructions

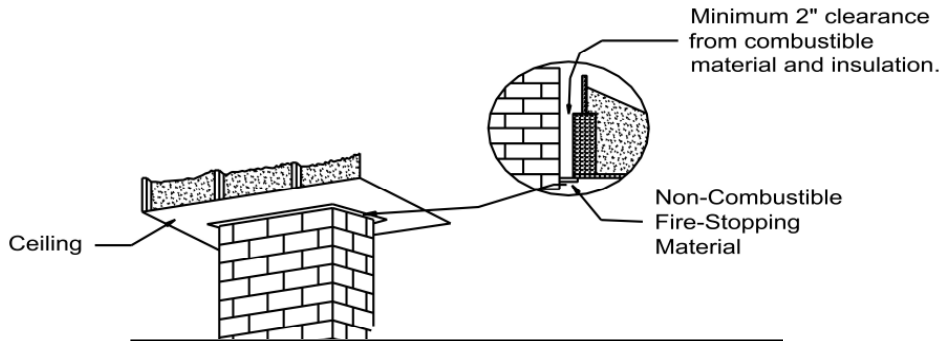


Fig. 11 Clearances—Masonry To Combustibles

- A chimney must be the required height above the roof or other obstruction for safety and for proper draft operation. The requirement is that the chimney must be at least 3 feet higher than the highest point where it passes through the roof and at least 2 feet higher than the highest part of the roof or structure that is within 10 feet of the chimney, measured horizontally (Fig. 12).

## THIMBLE

A thimble must be used when the connection from the stove is made through a combustible wall to a masonry chimney. There are several methods to use for connection through a combustible wall, two of which are illustrated in this manual. Local building authorities may be consulted or NFPA 211 may be used for additional methods of chimney connection.

Also, listed prefabricated metal thimbles may be purchased for use with wood stoves. The manufacturer's installation instructions for the thimbles must be strictly followed to assure the safety of the system. Be sure to maintain the designated clearance to combustible materials.

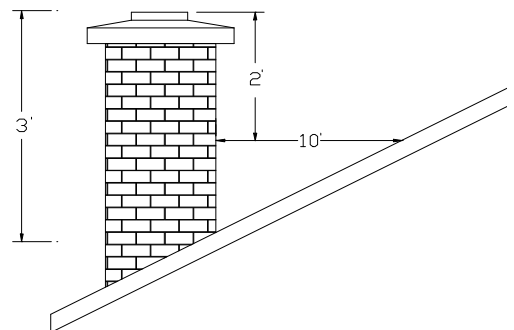


Fig. 12 Minimum Chimney Height

## Brick Chimney Thimble Assembly

Construction of the brick thimble assembly requires 12 inches of brick around a fire clay liner. Be sure the point of penetration allows an 18 inch clearance from the connector to the ceiling. An appropriate opening for a chimney connector must be cut in the wall to maintain the required 12 inches of brick separation from combustibles. It will be necessary to cut wall studs and install a header and sill frame to maintain proper dimensions and to hold the weight of the brick (Fig. 13). NOTE: Whenever cutting through a wall, check first with local building authorities to be sure building integrity is maintained. Minimum 3 1/2-inch (4-inch nominal) thick solid bricks are to be used. The fire clay liner (ASTM C35 or equivalent), minimum 5/8 inch wall thickness, must not penetrate into the chimney beyond the inner surface of the chimney flue liner and must be firmly cemented in place. If it is necessary to cut a hole in the chimney liner, use extreme care to keep it from shattering. Refractory mortar must be used at the junction to the chimney liner (Fig. 14). After the assembly is complete, insert the chimney connector in the fire clay liner. Do not push it beyond the inside edge of the chimney liner because this will affect the draw of the chimney.

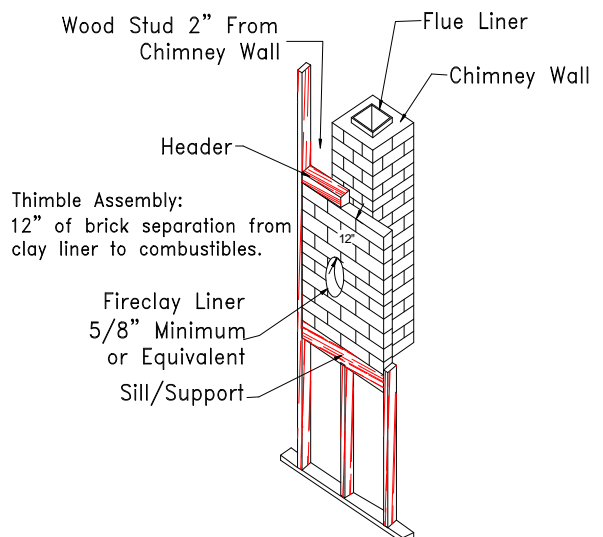


Fig. 13 Brick Chimney Thimble

# Installation – General Instructions

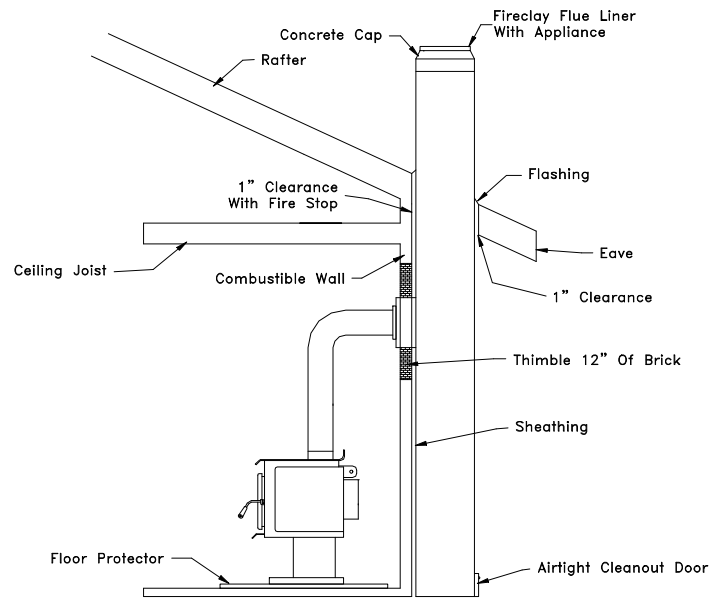
## Prefabricated chimney with metal supports as a thimble

For the method of installation to a masonry chimney shown in Fig. 15 and 16, it will be necessary to purchase a 12-inch long section of prefabricated listed chimney to use as a thimble. Purchase a wall spacer, trim collar and wall band that are manufactured to fit the chimney section you purchase.

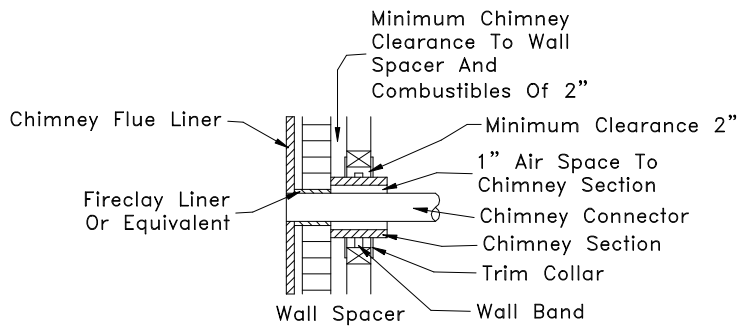
The safety features of this system are: the 2-inch air space between the chimney section and combustible wall, and the 1-inch air space around the chimney connector as it passes through the chimney section to the chimney.

The location of the opening through the wall to the chimney must leave a minimum 18 inch vertical clearance between the connector pipe and the ceiling to prevent the ceiling from catching fire.

For instructions on installation of the thimble, refer to chimney manufacturer's instructions.

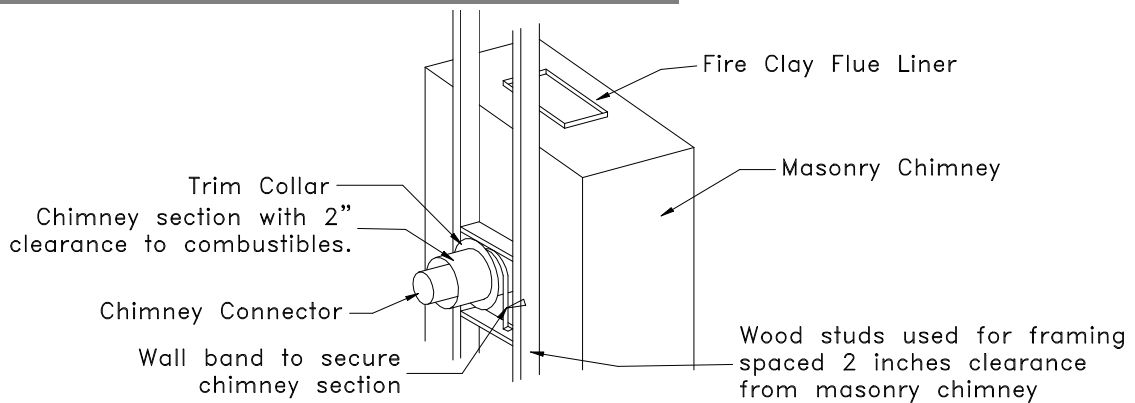


**Fig. 14 Masonry Chimney Construction, With Clearances**



**Fig. 15 Metal Prefabricated Thimble**

**If an exterior masonry chimney is used you may have draft problems due to the chimney being too cold. Exterior masonry chimney's should be lined with a listed stainless steel liner for the proper operation of these units.**



**Fig. 16 Metal Prefabricated Thimble**

## CONNECTION TO A METAL PREFABRICATED CHIMNEY

# Installation—General

When a metal prefabricated chimney is used, the manufacturer's installation instructions must be followed precisely. You must also purchase (from the same manufacturer) and install the ceiling support package or wall pass through and "T" section package, fire stops (when needed), insulation shield, roof flashing, chimney cap, etc. Maintain the proper clearance to the structure as recommended by the manufacturer. This clearance is usually a minimum of 2 inches, although it may vary by manufacturer or for certain components.

There are basically two methods of metal chimney installation. One method is to install the chimney inside the residence through the ceiling and the roof (Fig. 17 and 18). The other method is to install an exterior chimney that runs up the outside of the residence (Fig. 19 and 20). The components illustrated may not look exactly like the system you purchase, but they demonstrate the basic components you will need for a proper and safe installation.

The chimney must be the required height above the roof or other obstruction for safety and for proper draft operation. The requirement is that the chimney must be at least 3 feet higher than the highest point where it passes through the roof and at least 2 feet higher than the highest part of the roof or structure that is within 10 feet of the chimney, measured horizontally (Fig. 12).

## THIMBLE

When a wall exit installation is used, a listed assembly thimble must be installed. In a roof exit installation, the ceiling support box supplied with the manufactured chimney acts as a thimble.

**REMEMBER: Follow the manufacturer's installation instructions and maintain the manufacturer's specified clearance distances.**

Install an attic insulation shield to maintain the specified clearance to insulation. Insulation in this air space will cause a heat buildup which may ignite the ceiling Joists

The "Through The Roof" method of installation requires at a minimum a ceiling support package, an Insulation shield and roof flashing.

The "Through The Wall" method requires at a minimum a wall pass through device, a wall support package and insulated "T" section and roof flashing.

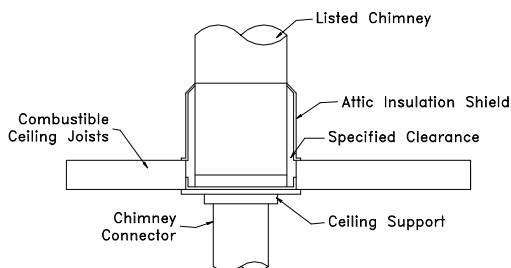


Fig. 18 Detail Of Connection Through Roof

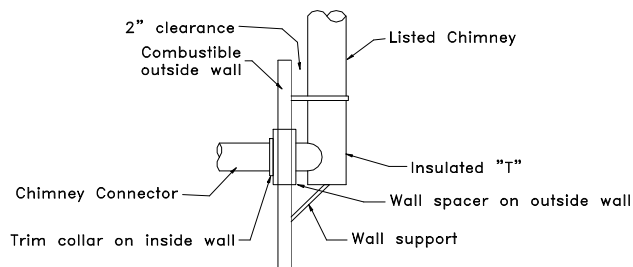


Fig. 20 Detail Of Connection Through Wall

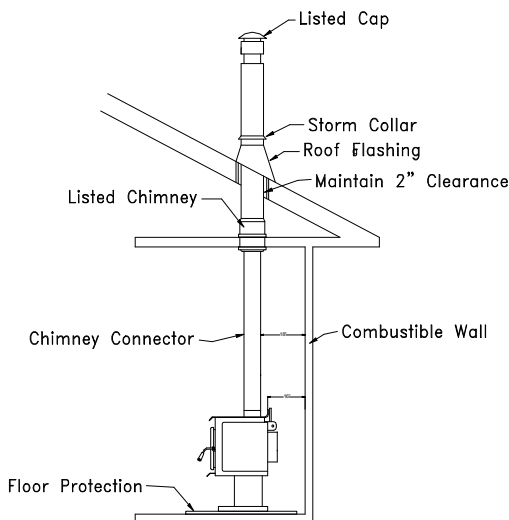


Fig. 17 Metal Prefabricated Chimney Through Roof

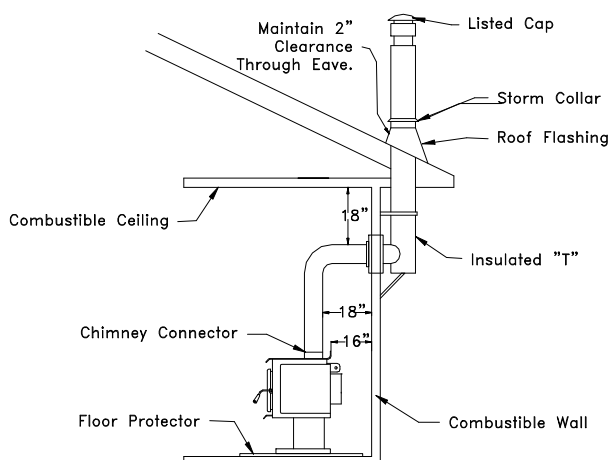


Fig. 19 Metal Prefabricated Chimney Through Wall



**Due to the high efficiencies of these units, Blaze King recommends the use of double wall pipe from the stove top to roof or wall exit.**

# Clearances To Combustible Surfaces

**FAILURE TO ALLOW THE REQUIRED CLEARANCES TO COMBUSTIBLE MATERIALS OR TO PROVIDE ADEQUATE FLOOR PROTECTION CAN CAUSE A HOUSE FIRE. SUCH A FIRE CAN RESULT IN DAMAGES TO PROPERTY AND SERIOUS INJURY OR DEATH.**

## Alcove Dimensional Requirements:

**Minimum Width 47" (KE 51"), Maximum Depth 48", Minimum Height above Stove Top, 49"**

**Total Alcove height for Classic (PE/KE)= 76"/ 81.25", Parlor (PE/KE)= 81"/ 84.50" and Ultra (PE/KE)= 82"/ 85.50"**

| Residential Installations  | PE1006 / PEJ1006 |              |                |              |              |                 | KE1107 / KEJ1107 |              |              |                |              |              | Fig.       |
|--|------------------|--------------|----------------|--------------|--------------|-----------------|------------------|--------------|--------------|----------------|--------------|--------------|------------|
|  | A                | B            | C              | D            | E            | F               | A                | B            | C            | D              | E            | F            |            |
| Roof exit, parallel and corner   | 16"<br>410mm     | 9"<br>230mm  | 26.5"<br>675mm | 16"<br>410mm | 14"<br>360mm | 24.75"<br>629mm | 16"<br>410mm     | 9"<br>230mm  | 27"<br>690mm | 16.5"<br>420mm | 14"<br>360mm | 25"<br>640mm | 21, 23     |
| Roof exit, reduced side Use side shields   | 10"<br>254mm     | 9"<br>230mm  | 20.5"<br>520mm | 16"<br>410mm |              |                 | 10"<br>254mm     | 9"<br>230mm  | 21"<br>534mm | 16.5"<br>420mm |              |              | 21, 23     |
| Roof exit, reduced corner Use side shields and either fan kit or rear shield                       |                  |              |                |              | 6"<br>153mm  | 16.75"<br>425mm |                  |              |              |                | 6"<br>153mm  | 17"<br>433mm | 21, 23     |
| Roof exit, close clearance Use side shields, and either fan kit or rear shield                     | 10"<br>254mm     | 6"<br>153mm  | 20.5"<br>520mm | 13"<br>330mm |              |                 | 10"<br>254mm     | 6"<br>153mm  | 21"<br>534mm | 13.5"<br>343mm |              |              | 21, 23     |
| Wall exit, parallel and corner   | 16"<br>410mm     | 11"<br>280mm | 26.5"<br>675mm | 18"<br>460mm | 14"<br>360mm | 24.75"<br>629mm | 16"<br>410mm     | 11"<br>280mm | 27"<br>690mm | 18.5"<br>470mm | 14"<br>360mm | 25"<br>640mm | 24, 25, 26 |
| Wall exit, reduced side. Use side shields  | 10"<br>254mm     | 11"<br>280mm | 20.5"<br>520mm | 18"<br>460mm |              |                 | 10"<br>254mm     | 11"<br>280mm | 21"<br>534mm | 18.5"<br>470mm |              |              | 24, 25, 26 |
| Wall exit, reduced corner. Use side shields and either fan kit or rear shield                      |                  |              |                |              | 7"<br>180mm  | 17.75"<br>451mm |                  |              |              |                | 7"<br>180mm  | 18"<br>460mm | 24, 25, 26 |
| Alcove, roof exit. Use side shields, and either fan kit or rear shield                             | 10"<br>254mm     | 6"<br>153mm  | 20.5"<br>520mm | 13"<br>330mm |              |                 | 9"<br>230mm      | 6"<br>153mm  | 20"<br>510mm | 13.5"<br>343mm |              |              | 22         |
| <b>Mobile Home Installation</b>  |                  |              |                |              |              |                 |                  |              |              |                |              |              |            |
| Roof exit, parallel and corner Use side shields, either fan kit or rear shield and outside air kit | 10"<br>254mm     | 6"<br>153mm  | 20.5"<br>520mm | 13"<br>330mm | 6"<br>153mm  | 16.75"<br>425mm | 10"<br>254mm     | 6"<br>153mm  | 21"<br>534mm | 13.5"<br>343mm | 6"<br>153mm  | 17"<br>433mm | 21, 23     |

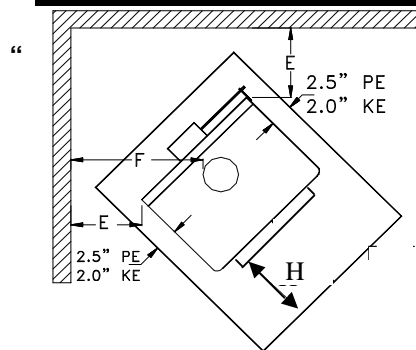


Fig. 21 Roof Exit Corner

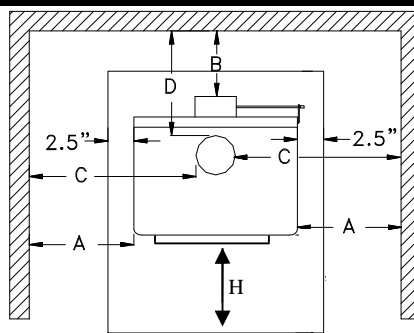


Fig. 22 Roof Exit Alcove

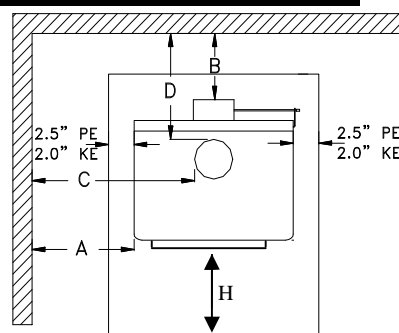


Fig. 23 Roof Exit Parallel

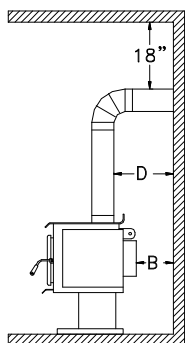


Fig. 24 Wall Exit Side View

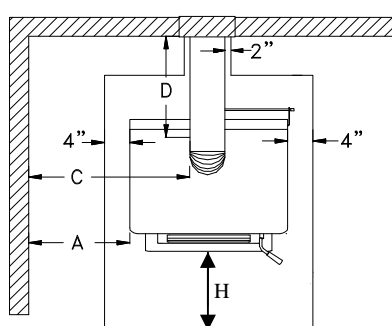


Fig. 25 Wall Exit Parallel

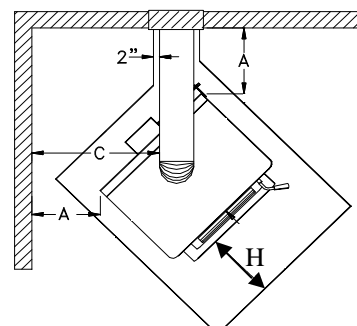


Fig. 26 Wall Exit Corner

**H= 18" (460 mm) in Canada, 16" in USA**  
**Clearances To Combustibles In Inches (") And millimeters (mm)**

# Installation Instructions

## NOTE

Following are requirements for both KEJ and PEJ, to attain clearances on the previous page. Various shield and fan kits are further described in the OPTIONS section, starting on page 29,

Where these instructions refer to "Listed, prefabricated chimney" that chimney and the accompanying close clearance connector must be a listed factory built chimney suitable for use with solid fuels and conforming to, ULC629 in Canada or UL-103HT in the USA.

1. KE1107 / KEJ1107 use 8" flue size (this should not be reduced). PE1006 / PEJ1006 use 6" flue size.
2. Residential roof exit parallel or corner installation, may employ any listed, prefabricated chimney system and 24 gauge blue/black single wall chimney connector. \*Blaze King does recommend the use of double wall pipe. Neither side shields nor rear heat shield/fan kit are required. Installation instructions begin on page 17.
3. Residential roof exit with reduced side clearances is possible by adding side shields. Single wall chimney connector, 24 gauge, is permitted with any listed Prefabricated chimney system. Installation instructions begin on page 18.
4. Residential roof exit with reduced corner clearances is possible with both side shields-and either rear shield OR fan kit installed. Single wall chimney connector, 24 gauge, is permitted with any listed prefabricated chimney system. Installation instructions begin on page 17.
5. Residential close clearance installations require side shields, a rear shield OR fan kit, and one of the listed, prefabricated HT chimney systems with matching double wall close clearance connector shown in figure 30. These requirements are the same as for a Mobile Home installation, except for the outside air kit. Installation instructions begin on page 17.
6. Residential wall exit, parallel and corner, use 24 gauge blue/black single wall chimney connector through a listed wall thimble assembly, or a site-built brick thimble, into any listed, prefabricated chimney system, or a site-built masonry chimney with tile liner. Neither side shields nor rear heat shield/fan kit are required. The horizontal section of the chimney must be at least 18" below the ceiling. Installation instructions begin on page 18. \*Blaze King recommends the use of double wall pipe and two 45° elbows instead of a single 90° elbow. A minimum 36" rise is recommended prior to any elbows being used.
7. Residential wall exit with reduced side clearances is possible by adding side shields. Single wall chimney connector, 24 gauge, is permitted. Connector must pass through a listed wall thimble assembly, or a site-built brick thimble, into any listed, prefabricated chimney system, or a site-built masonry chimney with-tile liner. The horizontal section of the chimney must be at least 18" below the ceiling. Installation instructions begin on page 18.
8. Residential wall exit with reduced corner clearances is possible with both side shields and either rear shield OR fan kit installed. Single wall chimney connector, 24 gauge, is permitted. Connector must pass through a listed wall thimble assembly, or a site-built brick thimble, into any listed, prefabricated chimney system, or a site-built masonry chimney, with tile Liner. The horizontal section of the chimney must be at least 18" below the ceiling. Installation instructions begin on page 21 (prefabricated chimney) or page 18 (masonry chimney).
9. Residential alcove, roof exit, requires a minimum ceiling height of 76". Also required are side shields, rear shield OR fan kit, and one of the listed, prefabricated chimney systems with matching double wall close clearance connector shown on page 28. For both KEJ and PEJ, minimum alcove width-is 47". Maximum alcove depth is 48". Minimum distance from bottom of either stove model, to ceiling of alcove, is 76". Installation instructions begin on page 24.
10. Mobile Home installations are only allowed with a roof exit. Mobile homes require side shields, either rear shield OR fan kit, an outside air kit, and one of the listed, prefabricated chimney systems with matching double wall close clearance connector shown on page 28. In Mobile Homes, overall installed height of stove with chimney system must be no less than 10.5 feet nor more than 20 feet. Installation instructions begin on page 24.
11. Clearance A is measured from the side of the stovetop. Clearance B is measured from the back center of the stove. Clearances C, D and F are measured from the round chimney connector collar on the stovetop, not from the chimney connector. Clearance E is measured from the back corner of the stovetop,



# Installation Instructions

## RESIDENTIAL, ROOF EXIT, STANDARD AND REDUCED CLEARANCE, WITH PREFABRICATED CHIMNEY.

Refer to Fig. 21 and 23. Clearances from Table #1

### BEFORE INSTALLATION

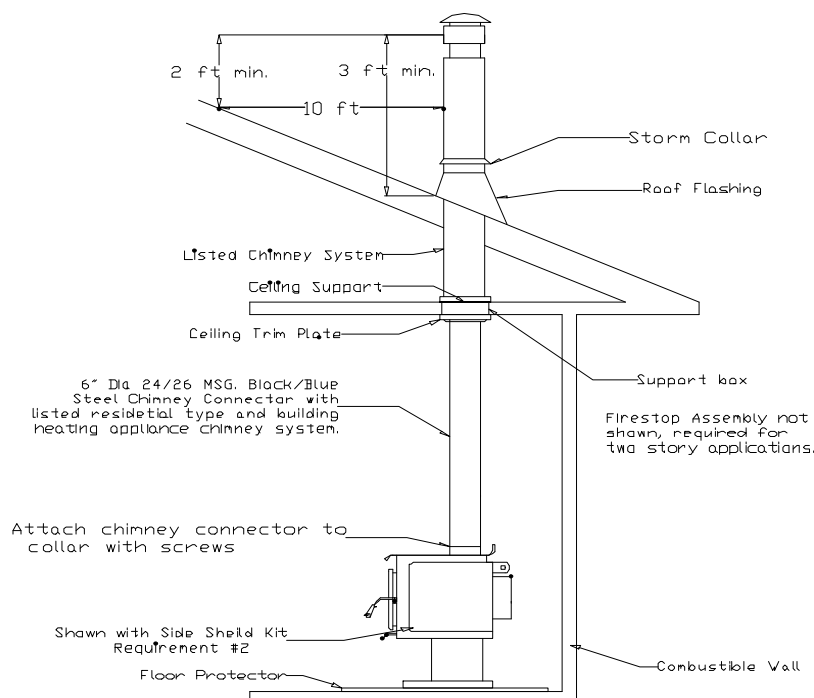
If the optional kits for the Jet Air fan, the Rear Shield, or the Side Shields are purchased, they are easiest to mount before the stove is installed. See instructions packed with each kit.

When a metal prefabricated chimney is used, the manufacturer's installation instructions must be followed precisely. You must also purchase (from the same manufacturer) and install the ceiling support package or wall pass through and "T" section package, fire stops (when needed), insulation shield, roof flashing, chimney cap, etc. Maintain the proper clearance to the structure as recommended by the manufacturer.

1. Set floor protection and stove in location; refer to the clearance dimensions listed on the label and in these instructions.
2. Mark the position for the hole in the ceiling and roof by using a string and plumb bob.
3. Check that the intended location will not interfere with floor joists, ceiling joists, or rafters before proceeding further.
4. IF REQUIRED, be sure to mark the hole for Outside Air Kit.
5. Move the stove out of the way, and if outside air is required, use a saber saw with a masonry blade and cut a 6.5" hole for the outside air pipe.
6. Cut a pilot hole in the ceiling.
7. Cut a hole for the ceiling penetration components and frame in the sides of this hole in both ceiling and roof. Refer to the pipe manufacturer's installation instructions.
8. Install the Support Box and Chimney through roof. Install the slip section for the Chimney Connector at this time. Refer to the pipe manufacturer's installation instructions.
9. Following the Manufacturer's Installation Instructions, slip the roof flashing down over the chimney and secure to the roof, being careful to keep the pipe centered in the opening.

**NOTE: To meet the code, the chimney must extend above the roof at least three feet and two feet above any area of the roof within ten feet of the termination of the chimney. Be sure all pieces( including outside air cap, flange, collar and pipe) are installed at this point before putting the stove in its final position.**

10. Slide the stove back into position.
11. To install the Chimney Connector, slip the lower (crimped) edge of the pipe inside the smoke collar. Install the remaining lengths of pipe, one on top of the other, to the finished height of the Chimney Connector, and secure to each other.
12. IF REQUIRED, install the Outside Air Flex Pipe.
13. If the OPTIONAL, Fan Kit is installed the fan motors are equipped with a THREE-PRONG (grounded) plug to prevent shock hazard THIS PLUG SHOULD BE INSERTED DIRECTLY INTO A PROPERLY GROUNDED, THREE-PRONGED RECEPTACLE. DO NOT CUT OR REMOVE THE GROUNDING PRONG FROM THIS PLUG. Do not route the power cord in front of or under this heater.



**Fig. 27 Residential Roof Exit, Prefabricated Chimney System**

# Installation Instructions

## RESIDENTIAL, WALL EXIT, STANDARD AND REDUCED CLEARANCE, WITH PREFABRICATED CHIMNEY

Refer to Figures 24, 25, and 26. Clearances from Table #1

### BEFORE INSTALLATION

If the optional kits for the Jet Air fan, the Rear Shield, or the Side Shield are purchased, they are easiest to mount before the stove is installed. See instructions packed with each kit.

When a metal prefabricated chimney is used, the manufacturer's installation instructions must be followed precisely. You must also purchase (from the same manufacturer) and install the ceiling support package or wall pass through and "T" section package, fire stops (when needed), insulation shield, roof flashing, chimney cap, etc. Maintain the proper clearance to the structure as recommended by the manufacturer.

1. Set floor protection and stove in location; refer to the clearance dimensions listed on the label and in these instructions.
2. Mark the position for the hole in the wall.
3. IF REQUIRED, be sure to mark the hole for Outside Air Kit.
4. Move the stove out of the way.
5. If outside air is required, use a saber saw with a masonry blade and cut an appropriate hole for the outside air pipe.
6. Cut pilot hole in the wall.
7. Cut the hole for the thimble components and frame in the sides of this hole. Install Listed thimble. Refer to the pipe manufacturer's installation instructions.
8. Follow the Manufacturer's Installation Instructions to install Prefabricated Chimney system. NOTE: To meet the code, the chimney must extend above the roof at least three feet and two feet above any area of the roof within ten feet of the termination of the chimney. Chimney connectors can be used horizontally between the stove and chimney if the horizontal length does not exceed three feet AND THE CONNECTOR SLOPES UPWARD TOWARD THE CHIMNEY AT 1/4" PER FOOT. The slope is required for water vapor to drain back into the stove. Use a carpenter's level to check the slope and the vertical alignment of the chimney connector. The connector may have no more than one 90 degree or two 45 degree bends. The distance between horizontal connector and ceiling must not be less than 18". All sections must be secured together and to the stove with no less than three sheet metal screws per joint. Be sure all options are installed before putting the stove in its final position.
9. Slide the stove back into position.
10. To install the Chimney Connector, slip the lower (crimped) edge of the pipe inside the smoke collar. Install the remaining lengths of pipe, one on top of the other, to the wall thimble. The last (horizontal) section must also be attached to the thimble with screws.
11. IF REQUIRED, install the Outside Air Flex Pipe.
12. If the OPTIONAL Fan Kit is installed, the fan motors are equipped with a three-prong (grounded) plug to prevent shock hazard. THIS PLUG SHOULD BE INSERTED DIRECTLY INTO A PROPERLY GROUNDED, THREE-PRONGED RECEPTACLE. DO NOT CUT OR REMOVE THE GROUNDING PRONG FROM THIS PLUG. Do not route the power cord in front of or under this heater.

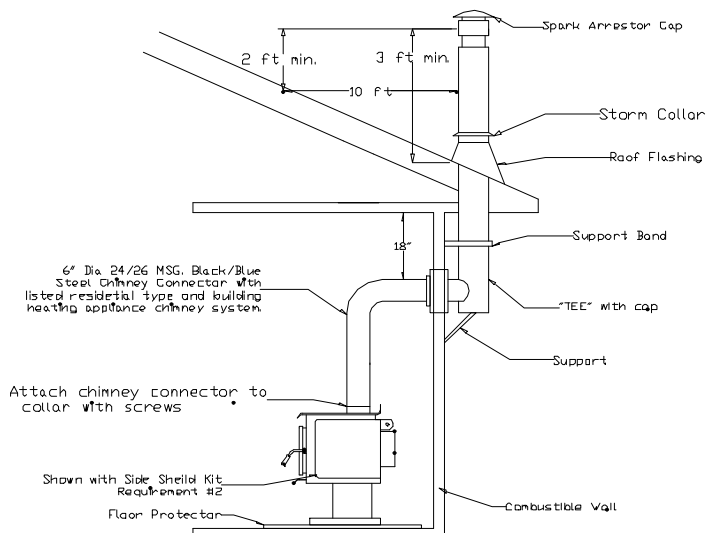


Fig. 28 Residential Roof Edit, Prefabricated Chimney

# Installation Instructions

## RESIDENTIAL, WALL EXIT, STANDARD AND REDUCED CLEARANCE, WITH MASONRY CHIMNEY

Refer to Fig. 24, 25, and 26. Clearances from Table #1

### BEFORE INSTALLATION

If the optional kits for the Jet Air fan, the Rear Shield, or the Side Shield are purchased, they are easiest to mount before the stove is installed. See instructions packed with each kit.

1. Set floor protection and stove in location; refer to the clearance dimensions listed on the label and in these instructions.
2. Mark position for the hole in the wall or masonry chimney.
3. IF REQUIRED, be sure to mark the hole for Outside Air kit.
4. Move the stove out of the way.
5. If outside air is required, use a saber saw with a masonry blade and cut an appropriate hole for the outside air pipe.
6. Cut pilot hole in the wall and/or masonry chimney.
7. Cut the hole for the wall penetration (thimble) components and frame in the sides of this hole. Install Listed Thimble or build masonry thimble, see page 17. Refer to the pipe manufacturer's installation instructions.
8. NOTE: to meet the code, the chimney must extend above the roof at least three feet and two feet above any area of the roof within ten feet of the termination of the chimney. Chimney connectors can be used horizontally between the stove and a masonry chimney, provided the horizontal length does not exceed three feet AND THE CONNECTOR SLOPES UPWARD TOWARD THE CHIMNEY AT THE RATE OF 1/4" PER FOOT. This slope in the horizontal section is required to allow the water vapor to drain back into the stove. Use a carpenter's level to check the slope. Also, check the vertical alignment of the chimney connector exiting the stove. The chimney connector may have no more than one 90 degree bend or two 45 degree bends. The distance between the horizontal connector and the ceiling must not be less than 18". All sections must be attached together and to the stove's flue collar with three screws per joint. Be sure all options are installed before putting the stove in its final position.
9. Slide the stove back into position.
10. To install the Chimney Connector, slip the lower (crimped) edge of the pipe inside the smoke collar. Install the remaining lengths of pipe, one on top of the other, to the wall thimble.
11. IF REQUIRED, install the Outside Air Flex Pipe.
12. If the OPTIONAL Fan Kit is installed, the fan motors are equipped with a three-prong (grounded) plug to prevent shock hazard. THIS PLUG SHOULD BE INSERTED DIRECTLY INTO A PROPERLY GROUNDED, THREE-PRONGED RECEPTACLE. DO NOT CUT OR REMOVE THE GROUNDING PRONG FROM THIS PLUG. Do not route the power cord in front of or under this heater.

**If an exterior masonry chimney is used you may have draft problems due to the chimney being too cold. Exterior masonry chimneys should be lined with a listed stainless steel liner for the proper operation of these units.**

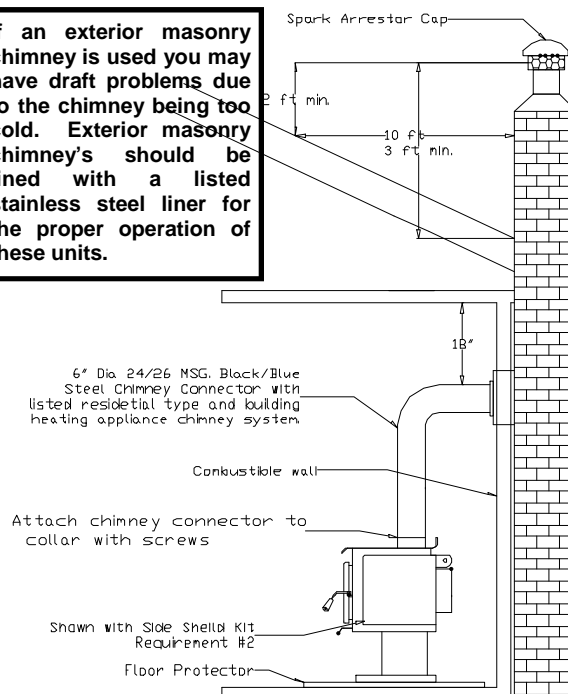


Fig. 29 Residential Wall Exit, Masonry Chimney



# Installation Instructions

## MOBILE HOME AND RESIDENTIAL ALCOVE, ROOF EXIT, PREFABRICATED CHIMNEY

Refer to Fig. 21, 22, and 23 Clearances from Table #1

### BEFORE INSTALLATION

Side Shields and either Rear Shield OR Fan kit are required for these installations. They are easiest to mount before the stove is installed. See instructions packed with each kit.

When a metal prefabricated chimney is used, the manufacturer's installation instructions must be followed precisely. You must also purchase (from the same manufacturer) and install the ceiling support package or wall pass through and "T" section package, fire stops (when needed), insulation shield, roof flashing, chimney cap, etc. Maintain the proper clearance to the structure as recommended by the manufacturer.

### NOTES:

1. For MOBILE HOME AND RESIDENTIAL ALCOVE installations, use these instructions with Side Shield Kit (KE1107, S/SK1107; PE1006, S/SP1003) and either Rear Shield (KE1107, R/SK1107; PE1006, R/SP1006) or Fan Kit: Z1714. Chimney connector must be double wall close clearance type, and must be of same brand and model as listed prefabricated chimney. Single wall pipe is not allowed in Mobile Homes or in Alcove Installations. Insulated chimney components must be a listed factory built chimney suitable for use with solid fuels and conforming to, ULC629 in Canada or UL-103HT in the USA. For MOBILE HOME installation you also require the Outside Air Kit: FAKIT.

### WARNING - DO NOT INSTALL IN SLEEPING ROOM

### CAUTION - THE STRUCTURAL INTEGRITY OF THE MOBILE HOME FLOOR, WALL AND CEILING/ROOF MUST BE MAINTAINED.

1. Set floor protection and stove in location; refer to the clearance dimensions listed on the label and in these instructions.
2. Mark the position for the hole in the ceiling and roof using a string and plumb bob.
3. Check that the intended location will not interfere with floor joists, ceiling joists, or rafters before proceeding further.
4. Mark the positions for the tie down and the hole for the outside air pipe.
5. Move the stove and using a saber saw with a suitable blade, cut a hole for the outside air pipe and install as per instructions. Drill a pilot hole for the tie down.
6. Cut a pilot hole in the ceiling.
7. Cut a hole for the ceiling penetration components and frame in the sides of this hole in both the ceiling and roof. Refer to pipe manufacturers installation instructions. Install the support box. Be sure all pipe parts, including outside air cap, flange, - collar and pipe (and all stove options) are installed at this point before putting the stove in its final position.
8. Slide the stove back into position.
9. Install the tie down.
10. To install close clearance connector to the stove, slip the lower (crimped) end inside the smoke collar. Fasten chimney connector to stove with screws provided. Slide connector up and snap into ceiling support. (Make sure it "snaps" in place.) Refer to the pipe manufacturer's Installation Instructions.
11. Following the pipe manufacturer's Installation Instructions, install chimney system into support box, slip the roof flashing down over the chimney and secure to the roof, being careful to keep the pipe centered in the opening.

**NOTE: To meet the code, the chimney must extend above the roof at least three feet and two feet above any area of the roof within ten feet of the chimney termination.**

12. Install the Outside Air Pipe 3" flex tube.
13. If the OPTIONAL Fan Kit is installed, the fan motors are equipped with a three-prong (grounded) plug to prevent shock hazard. THIS PLUG SHOULD BE INSERTED DIRECTLY INTO A PROPERLY GROUNDED, THREE-PRONGED RECEPTACLE. DO NOT CUT OR REMOVE THE GROUNDING PRONG FROM THIS PLUG. Do not route the power cord in front of or under this heater.

**NOTE: In mobile home installations, the stove must be securely fastened to the floor using the tie-downs provided.**

**ALSO, a #8 ground wire must be attached to the stove and an appropriate ground.**

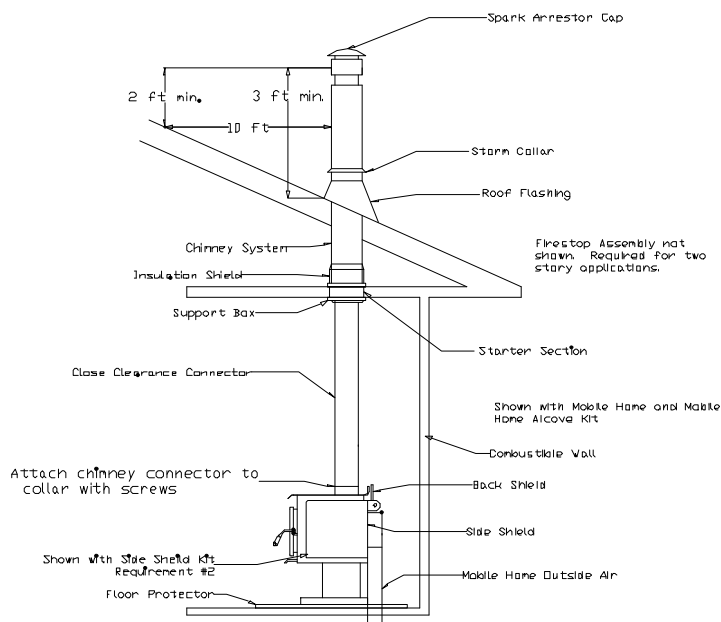
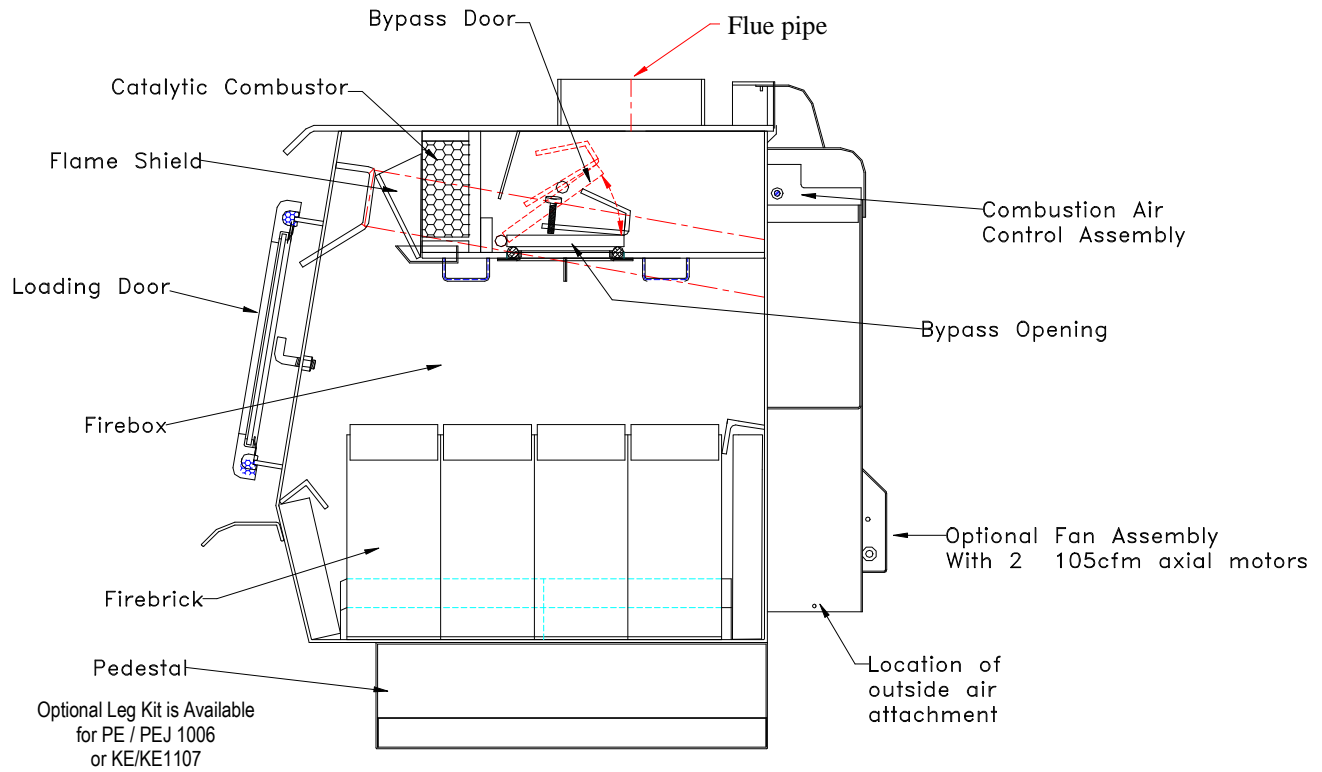


Fig. 30 Mobile Home, Residential Close Clearance and Alcove , Roof Exit

# Cutaway View



**Fig. 31 Cutaway View with major internal components — Model PEJ1006, KE1107**

# Optional Accessories

**SIDE SHIELD KIT, KE1107 (P/N S/SK1107)**

**SIDE SHIELD KIT, PE1006 (P/N S/SP1006)**

SIDE SHIELDS ARE STANDARD ON THE ULTRA MODEL

**REQUIRED FOR:** MOBILE HOME, any installation  
RESIDENTIAL REDUCED CLEARANCE  
RESIDENTIAL ALCOVE

## TOOLS NEEDED FOR INSTALLATION

1. Pliers, or wrench

## INSTALLATION (both models)

1. Place one of the Side Shields in place on the stove. (The shields will only fit on the sides for which they are intended.) Slide the tab on shield top under the clip that is just under the top of the stove.
2. Hold the shield tight on the side of the stove. Slide to front and to back until holes in bottom of side shield align with holes in bottom of stove.
3. Drop one bolt through each hole. Place nut on bottom of bolt and tighten.
4. Install the other shield.

**REAR SHIELD KIT, KE1107 (P/N R/S1107)**

**REAR SHIELD KIT, PE1006 (P/N R/SP1006)**

EITHER this Rear Shield OR the Fan Kit (P/N Z1714) is REQUIRED FOR:  
MOBILE HOME, any installation  
RESIDENTIAL ALCOVE  
RESIDENTIAL CLOSE CLEARANCE

## TOOLS NEEDED FOR INSTALLATION

1. Phillips or square drive screwdriver.

## INSTALLATION (both models)

1. The rear shield goes across the back of the stove, just below the thermostat knob. Place shield into position, insert and tighten the two #10 X 1 1/4" screws provided.

# Optional Accessories

**FAN KIT ASSEMBLY**, KEJ and PEJ (P/N Z1714) either this Fan Kit or the Rear Shield (KE # R/S1107 or PE # R/SP1006) is **REQUIRED FOR**: MOBILE HOME, ANY INSTALLATION  
RESIDENTIAL ALCOVE  
RESIDENTIAL CLOSE CLEARANCE

NOTE: Fan Kit should be installed before the stove is placed into position

## TOOLS NEEDED FOR INSTALLATION

1. Square (Robertson) screw driver.

## INSTALLATION (both models)

Fan kits are shipped fully assembled and electrically wired. Each fan assembly is held to the back of the stove with two screws.

To begin, remove the two plates behind the vents at the top back of the stove. Replace all screws.

Re-move fan kit from packaging and inspect, paying particular attention to the fans. The fan blades must turn freely.

Each fan/fan tube assembly attaches with the fan at the bottom, and the assembly with the speed control switch on the same side as the thermostat and bypass controls.

Hook the top of the fan tube over the stovetop and inside the stove top vent. Start the screw that is below the fan, into the slotted bracket on the bottom back of the stove body. Align the assembly so that the fan tube is parallel with the main air tube down the center of the stove.

Tighten the screw below the fan to push the fan tube up. Tighten the top screws so the entire assembly is snug against the stove body.

Manufacturing tolerances allow some space around control shafts and welds. The intent is to minimize the air gaps around the tube, and to lessen the possibility of rattles.

## ELECTRICAL CONNECTION

Your Blaze King fan kit is equipped with a three-prong (grounded) plug to decrease shock hazard. **THIS PLUG SHOULD BE INSERTED DIRECTLY INTO A PROPERLY-GROUNDED, THREE-HOLE RECEPTACLE. DO NOT CUT OR REMOVE THE GROUNDING PRONG FROM THIS PLUG.** Do not route the power cord in front or under the stove.

**Note:** "When your Blaze King is equipped with the Dual Fan assembly, remember that air movement across the top of the stove can cause an inaccurate thermometer reading. Simply turn off your fans at the rheostat for 5 minutes to allow for a corrected reading."

# Optional Accessories

**OUTSIDE AIR KIT**, KEJ and PEJ (PIN 1726B)

**REQUIRED FOR:** ALL MOBILE HOME INSTALLATIONS  
**OPTIONAL FOR:** ALL RESIDENTIAL INSTALLATIONS

## TOOLS NEEDED FOR INSTALLATION

1. 1/4" or 3/8" drill motor
2. Saber saw
3. Saber saw wood & metal blades
4. 5/16" nut driver or wrench
5. 7/16" wrench
6. Small tube of hi-heat silicone

The outside air inlet hose is a flexible tube to bring outside air for combustion into the stove from outside the residence, through the wall or up through the floor. The flexible tube will allow some adjustment over or around floor joists or plumbing. **DO NOT CHANGE THE STRUCTURAL INTEGRITY OF THE FLOOR.** This air hose must be kept open at all times to provide outside air for combustion.

## INSTALLATION (both models)

1. Set floor protector and stove in location for marking holes in accordance with the dimensions listed on the label and figures of these instructions.
2. Check that the intended location will not interfere with floor joists, ceiling wiring or plumbing.
3. Mark the positions for the tie down and the hole for the outside air pipe.
4. Move the stove and using a saber saw with a suitable blade, cut a 6-1/2" hole for the outside air pipe. Drill a pilot hole for the tie down.
5. Install the outside air cap on the bottom of the main tube with two #10 x 3/8" screws.
6. Install the outside air pipe to the outside air flange and collar with two #10 x 3/8" sheet metal screws.
7. Install the outside air pipe through the floor. Drill pilot holes and attach the outside air flange to the floor with four 1/4" x 3/4" screws.
8. Position the stove in its intended location. Secure to floor with 1/4" x 3" lag screws, or if you have a leg model use Blaze King kit # ZR8039 (leg anchor kit)
9. Attach the outside air hose to the outside air cap with the outside air hose clamp. Push the other end of the outside air hose into the outside air flange and seal with high temperature silicone.



# Operation

Your stove's performance (including its efficiency, pollutant emission level and service lifetime) depends largely on how it is operated. You, then, are the most important factor affecting performance. Read these operation instructions carefully.

**BEFORE PROCEEDING FURTHER, be sure to read the following:**  
**SAFETY INFORMATION: Pages 12 through 15.**  
**CLEARANCES TO COMBUSTIBLE MATERIALS: Pages 23 through 29.**  
**FLOOR PROTECTION INFORMATION: page 18.**

The six major needs of a well-controlled fire are:

1. A knowledgeable and conscientious operator.
2. Adequate-air supply and minimum .02" draft.
3. Firewood of good quality and proper size.
4. Catalytic combustor in good condition.
5. Clean chimney, properly sized and installed.
6. Clean heat exchangers with tight gaskets and seals.

All of these needs are interrelated. A deficiency in any one will affect all of the others. If you encounter a problem, determine the source of the problem and follow up by checking the other needs for possible problems. All things considered, point number one is the most important for the safe and efficient operation of any stove. Please study the following carefully, so you may become, and remain, a knowledgeable and conscientious operator.

## **WARNING - PROVIDE ADEQUATE AIR CIRCULATION**

It is essential that a source of fresh air for combustion be provided at all times when this woodstove is in operation. In extremely tight houses, partially open a window near the woodstove or install an Outside Air Kit.

## **FUEL**

THIS WOODSTOVE IS FOR USE WITH SOLID WOOD FUEL ONLY. NEVER USE GASOLINE, GASOLINE-TYPE LANTERN FUEL, KEROSENE, CHARCOAL LIGHTER FLUID OR SIMILAR LIQUIDS TO START OR 'FRESHEN UP' A FIRE IN THIS HEATER. KEEP ALL SUCH LIQUIDS WELL AWAY FROM THE HEATER WHILE IT IS IN USE.

Do not burn materials soaked in flammable liquids, trash, garbage artificial or paper logs, plastics, gift wrappings, coal, charcoal, naphtha, engine oil, chemical cleaners, chemical fire starters, treated or painted wood, saltwater driftwood, railroad ties, plywood, particle board. Do not burn sawdust, wood shavings, pellets or chips in this woodstove. The use of saltwater driftwood will void the warranty.

*CAUTION: Do not place wood fuel within the space heater installation clearances or within the space required for fueling and ash removal.*

*CAUTION: Do not over fire. If heater or chimney connector glows, you are over firing. Keep loading door and bypass door closed when stove is in operation.*

## **INITIAL START-UP SEQUENCE**

NOTE: As you heat up the stove for the first time, the paint will go through a curing process and will give off an odor. To minimize the inconvenience, burn the stove at a low temperature setting for several hours. If the odor gets unpleasant, you may have to open a door or window slightly until the odor dissipates. It might even be a good idea to burn the first fire with the stove outside.

1. DO NOT USE A GRATE. BUILD THE FIRE DIRECTLY ON THE BRICK IN THE BOTTOM OF THE STOVE.
2. Set the thermostat to high (maximum) position, i.e. position at "3".
3. Open the loading door and open the by-pass door.
4. Place five to ten balls of paper in the firebox and place a fairly large quantity (15-20) pieces of kindling on top of the paper.
5. Lay two or three medium size (approx. 3") pieces of wood on top of the kindling. Light the fire and allow it to get a good start but DO NOT LEAVE THE STOVE UNATTENDED.
6. When the fire has the larger pieces of wood burning, close and latch the loading door, but leave the by-pass door open. Turning down the thermostat too soon may cause a new fire to go out. Allow the kindling and most of the larger logs to get started before latching the loading door. DO NOT leave your BLAZE KING unattended when the doors are not tightly closed. Leaving the loading door open AFTER the fire is well started may cause premature failure of the catalytic combustor.

# Operation

1. When nearly all the wood in the firebox is burning, finish loading the stove. Lay the wood front to back, as far to the back of the stove as possible. At this time you should close the bypass door.

*CAUTION: Do not abuse the glass door by slamming it or striking it. Do not force the door closed if there is wood in the firebox that is obstructing it.*

Other than during the initial startup sequence, DO NOT burn the stove with the by-pass open. Leaving the by-pass open may APPEAR to achieve a hotter fire (the flames look more active) but, in fact, just the opposite is true. Bypassing the catalyst allows as much as 50% of the potential fuel - and therefore heat - to go directly up the chimney. These Blaze King catalytic stoves produce their greatest amount of heat when the by-pass is closed, and the catalyst is active.

Probably the least understood requirement in maintaining a good fire is that of establishing a good base of coals. Many new stove users hesitate to load enough wood to sustain a fire. Put as much fuel into the stove as it will hold. Don't be afraid to fill it completely. With the Blaze King automatic thermostat, the wood will only burn at the rate set on the thermostat. Loading with a half load of fuel, and therefore reloading more often, causes the catalyst to lose efficiency and may result in a faster creosote deposit. A good bed of hot coals will maintain a more even temperature as well as getting the new load of wood started easily.

2. With optional fans. After the firebox has warmed up (about 30 minutes) turn the fans on. The fans should be run at low when the stove is burning on low. With the stove on medium, set the fans to medium. Set them on high when the stove is burning high.
3. Let the fire burn on setting 2-3 for 20-30 minutes, or until the fire is well established, then turn the thermostat to the desired setting.

## OPTIMUM THERMOSTAT SETTING

Any thermostat position between 1 and 3 will produce the desired clean burning characteristics. However, since each application can vary, you may find it necessary to operate the thermostat to suit your application. A thermostat setting of 3 will produce a maximum heat which is more than suitable for heating the average size home.

1. Starting the fire (see Initial Startup Sequence, page 32 and the Addendum). Each stove/home/installation/homeowner combination works a little differently. The first several times you fuel the stove, it may not react as you expect. A little experimentation may be needed to find the right combination of fuel and thermostat setting to achieve the maximum efficiency. This is one of the joys of burning wood. You, the wood burner, make it work. And you can see what happens as it is working. Be Patient. The air/fuel mixture and temperature must be stabilized before maximum combustion efficiency can be achieved.
2. As the combustor temperature (as indicated by the thermometer on top of the stove) passes into the active zone, further adjustment to achieve the desired room temperature should be made in small increments (for instance, from position 3 to position 2.5) for the most effective cleaner burning operation. Even this small change may reduce the clean burn slightly for 10-15 minutes. Changes, generally speaking, should be made as few times each day as possible. When the thermostat knob is moved from high to low, more smoke is produced, so the catalyst has more fuel; consequently the catalyst thermometer may register a higher heat for several hours after the thermostat is turned down.
3. When you reload the stove you will reduce the clean burning characteristics until the new wood gets a good start.
4. The thermostat is adjusted at the factory and should not be tampered with. If the thermostat breaks, the damper will close automatically.

## FAN OPERATION (Optional on KE / PE Standard on KEJ / PEJ)

If you have the Optional Fan Assembly installed, The fan should be adjusted to its lowest setting until your fire has been established for 30 minutes. After the thirty minute fire start up time the fan speed adjustment should match the thermostat control setting, i.e. if your stove is set at medium then your fan should also be set at medium, low—low, high—high etc. Note: the fan speed is at its maximum immediately after the “on” position and reduces as you turn clockwise.

The fan assembly is controlled by an on/off temperature sensor as well as a fan speed control. The fire will have to heat the stove to the predetermined sensor temperature before the fan will come on. Usually this takes about 1 hour if the stove is started from cold.

# Disposal Of Ashes

\*\*\*\*\***WARNING**\*\*\*\*\*

**NEVER STORE HOT ASHES IN A GARAGE OR BASEMENT. HOT ASHES WILL GENERATE CARBON MONOXIDE AND/OR FLAMMABLE GASES. THESE GASES MAY CAUSE SUFFOCATION**

Ashes should be placed in a metal container with a tight fitting lid. The closed container of ashes should be placed on a noncombustible floor or on the ground, well away from all combustible materials, pending final disposal. If the ashes are disposed of by burial in soil or otherwise locally dispersed, they should be retained in the closed container until all cinders leave thoroughly cooled.

## **RELOADING & Maintaining an efficient fire.**

A bed of hot coals is the most important requirement for keeping an efficient fire. A bed of hot coals will help the stove maintain a more even temperature as well as getting the new load of wood started easily. Many new woodstove users hesitate to load enough wood to sustain a fire, fearing that a full woodstove automatically means a hot fire. The combustion air control, set at the lowest air control setting, permits a low fire even with the firebox full. At each reloading, load the stove fully. It is neither necessary nor desirable to open the door often. Every time the door is opened, more creosote is deposited in the chimney. Let each load burn down to a coal bed. Frequent reloading may cause major fluctuations in temperature and fuel/air mix, thereby reducing efficiency. A full load of fuel may burn for 24 hours or more. This will change considerably with the variables of stove model, type of wood, whether the wood is "seasoned", the thermostat setting, the position of the stove in the house, and how well the house is insulated. The stove can be FULLY loaded without increasing the heat output. The fire will simply burn longer.

## **RELOADING SEQUENCE**

1. As much as possible, let each load of fuel burn down to a few coals before reloading.
2. Open the bypass by rotating the bypass handle fully counter clockwise to the stop. Set the thermostat to high.
3. Open the loading door gently. Pulling it open quickly could pull smoke or flames into the room. This stove is not designed to be operated with the door open. Except for loading or reloading, operate only with the door closed.

## **WARNING**

**ALWAYS OPEN THE BYPASS AND THE LOADING DOOR TO ALLOW THE FIRE TO BUILD UP SLIGHTLY BEFORE FULLY OPENING THE LOADING DOOR. IF THE LOADING DOOR IS OPENED TOO FAST, THE SUDDEN INTRODUCTION OF AIR CAN CAUSE THE FIRE TO FLARE AND DISCHARGE SMOKE AND FLAME INTO THE ROOM. SUCH A DISCHARGE MAY BURN PERSONS WHO ARE NEAR THE WOODSTOVE.**

4. With a poker, pull the glowing coals to the front center of the firebox. Leave, as much as possible, an open channel between pieces of wood in the center of the stove. (This channel makes a natural chimney and gets the fire started quickly). Leave the door standing open long enough to know the new fuel will ignite.
5. When the new load has ignited, close and latch the door, but leave the by-pass open.
6. When the fuel is burning well, close the bypass, turn the thermostat to the desired setting, and turn the room air fans to the proper speed. After the fire has been allowed to liven up and the door closed, DO NOT open the door for at least 4-5 minutes. Hot gasses build up right after the door is closed and the addition of oxygen when the door opens will cause a rapid combustion, sending smoke (and possibly flame) into the room. Always open the bypass door BEFORE opening the loading door. Keep the by-pass door closed at all other times.
7. Thermostat Adjustment. Leave the air control in the fully open position (3) for 15 minutes, (or until the fire is well established) before making further adjustments. Turning down the thermostat too soon may cause creosote formation in the chimney. Once the fire is well established, adjustments may be made for a Low, medium or high fire, depending on heat needs of the home. The glass will stay cleanest when the new load of fuel is burned on high for up to 30 minutes. The moisture in a new load contributes a large part of the deposit on the glass. Burning that moisture off, before turning the thermostat to low, helps keep the glass clean. For a low fire, (12,000 to 15,000 Btu/hour) getting the fire well established is particularly critical. If the wood being used is not well seasoned, it may be necessary to leave the air control setting in the fully open position for much longer than 15 minutes to assure a clean, low burn. When the fire is burning well on high, reset the air control in steps to medium, then lower, over a 5-10 minute period.

For a medium burn (16,000 to 22,000 Btu/hour) leave the air control set at high ("3") for 15 minutes, or until the fire is well established. Then move the air control to the medium setting. For a high fire (30,000 to 40,000 Btu/hour) the air control setting may be left on high at all times.

**NOTE: Turning the thermostat down will often cause the catalyst temperature to go up, for a period of up to several hours. This is due to the greater amount of smoke (catalyst fuel) produced by a lower fire.**

# Maintenance

## ASH REMOVAL

Ashes may be removed at any time, but must be removed when they approach the level of the door opening. **DO NOT** remove all ashes from the stove as a wood fire burns best when made on a bed of ashes.

The frequency with which you need to empty the ashes depends on the type of fuel being used. Hardwoods, unless the coals are raked to the front of the firebox before each reloading, will leave more ashes than softwoods. Remove ashes only when they are cold so the hot coals are not dumped where they may start a fire.

Ashes should be placed in a metal container with a tight fitting lid. The closed container of ashes should be placed on a non-combustible floor or on the ground, well away from all combustible materials, pending final disposal. If the ashes are disposed of by burial in soil or otherwise locally dispersed, they should be retained in the closed container until all cinders have thoroughly cooled.

**If you purchased a leg model PE or PEJ with the optional ash drawer kit or a ULTRA model with the standard ash drawer, then please see the addendum on page 45 and instructions that came with your ash drawer.**

## AUTHORIZED SERVICE REPRESENTATIVE

Your local BLAZE KING dealer is your authorized service representative. Should you have any problems with operating or maintaining your BLAZE KING stove, contact him as soon as possible. The dealer will help you solve operating problems, provide replacement parts, and/or arrange warranty service repairs as required. Dealers will need information such as model, serial number, date of purchase, and a summary of the problem.

## CREOSOTE FORMATION

When wood is burned slowly, it produces tar and other organic vapors which combine with expelled moisture to form creosote. If not burned by the catalyst, the creosote vapors condense in the flue of a slow-burning fire. As a result, creosote residue accumulates on the flue lining. When ignited, this creosote makes an extremely hot fire. When in good condition and operated properly, your Blaze King catalyst-equipped stove is clean-burning. So, if significant creosote buildup occurs, reexamine your fire building and burning procedures. Most instances of creosote buildup in the chimneys of catalytic woodstoves are due to operator error. If you still have questions consult your dealer or contact the Customer Service department at Blaze King.

## INSPECT CHIMNEY TWICE MONTHLY

Inspect your chimney and chimney connector at least twice each month during the heating season. Creosote may form in the chimney connector or the entire flue and flue cap, or may appear as patches in one or more places in the system. It may be a thin, hard glaze that is very difficult to remove, a large fluffy mass, barely harder than cotton candy, or a solid plug, literally closing the chimney so that the fire will not burn.

Patches of creosote in your chimney connector indicate a possible air leak. Any leak must be repaired. A chimney fire or deterioration can enlarge the leak. This will admit more air and cause exhaust gases to condense and form additional creosote. If a significant amount of creosote has accumulated, it must be removed to reduce the risk of a chimney fire.

## REMOVAL

**NEVER** intentionally start a chimney fire to clean the flue. **DO NOT** clean the chimney while it is still connected to the stove. Remove the bottom section of pipe and attach a bag to the chimney to catch any creosote removed. Hire a certified chimney sweep or clean the chimney yourself with a tight-fitting chimney brush. Makeshift equipment--hoses, tire chains, etc.--can damage the flue and will probably do an unsatisfactory cleaning job. After cleaning the chimney, clean inside the top of the stove. Scrape, if needed, and vacuum all creosote and fly ash from area around the by-pass door. Re-install the first section of pipe to the stove. Refer to the Installation Instructions.

## LOADING DOOR GASKET INSPECT TWICE YEARLY. REPLACE WHEN NEEDED.

Safe and efficient operation of an airtight woodstove depends greatly on the integrity of the gaskets. Therefore, it is imperative that the loading door gasket be checked at least twice each heating season. A loose or improperly adjusted loading door may make the stove hard to control, and will speed door gasket deterioration.

Instructions for tightening the gasket can be found on page 13.

# Maintenance

## GASKET INSPECTION

Inspect the gasket for physical deterioration, missing sections or obvious leakage-. The stove front should make a groove in the gasket material - one side of the groove (toward the inside) will often be dark or black, and the other side (toward the outside) should be light or white. Dark smudges on the outside of the groove may indicate a smoke leak. If the groove is very shallow or missing, or if there is a heavy ash or creosote deposit along the bottom edge of the gasket, it may need to be replaced. Frayed or broken gasket material, or a gasket that is hard and unyielding, will also indicate need for replacement. Any time a piece of gasket is missing, or is broken anywhere, the entire gasket must be replaced. To check the gasket further, insert a piece of paper (a dollar bill will work) into the door opening and close and latch the door. Obvious resistance should be felt when pulling the paper out. Repeat this check several times around the perimeter of the door.

Instructions for tightening the gasket can be found on page 13.

## GASKET REPLACEMENT

1. If the door gasket is to be replaced, be sure you have some 7/8" fiber glass gasket material, ready to re-install. See your Blaze King dealer.
2. Be sure the fire is out and the stove has cooled down. The door does not have to be removed from the stove.
3. With a pair of pliers, pull the old door gasket out of the channel and dispose of it.
4. Thoroughly clean out the channel so the new silicone adhesive will adhere and the gasket will fit smoothly
5. Run a small bead of a high temperature silicone adhesive (such as G.E. Silicone Sealer, or the equivalent) along the center of the channel. DO NOT USE HOUSEHOLD SILICONE CAULKING. High temperature silicone may be obtained from most auto parts stores.
6. Start the new gasket in the lower right corner. Do not stretch or cut the gasket. Distribute the gasket evenly
7. around the frame.
8. Close the Loading Door and allow the adhesive to dry.
9. Door adjustment: the door seal is adjusted by turning the latch catch on the stove in or out. NOTE THERE IS A LOCK NUT ON THE LATCH THREAD ON THE OUTSIDE OF THE STOVE, LOOSEN THE LOCK NUT FIRST and then thread the latch catch in or out to properly adjust the door seal. The gasket should be just tight enough to test ok as in step 10, do not over tighten the latch which makes the door difficult to latch.
10. Check the fit of the door gasket. Insert a narrow strip of paper into the door opening and close and latch the door. Obvious resistance should be felt when pulling the paper out. Repeat this check several times around the perimeter of the door.

## CATALYTIC COMBUSTOR, TESTING (Conduct test with fans off)

Test the catalyst in your Blaze King as follows:

Build a fire using the same technique (paper, kindling, logs) you have used in the past. Leave the thermostat knob on a medium (2) setting. When the fire is well established (within one to three hours) turn the thermostat knob to 1.5 or 1.75. A properly operating catalyst will remain active, and the catalyst thermometer will remain in the "active" zone until the wood load is mostly consumed. A "tired" or "dead" catalyst will, with the thermostat on 1.75 or lower, go out completely, and the thermometer needle will fall into the "inactive" zone. Repeat this procedure several times over several days. (Remember that the catalyst thermometer has a built-in lag of 4-8 minutes.) If, after several test burns, the thermometer will not indicate an "active" catalyst, it may require cleaning or replacement. It is also possible that the thermometer, itself, may not be reading accurately. Before condemning the catalyst, read "Thermometer", on page 38.

## CATALYTIC COMBUSTOR, CLEANING

Under certain conditions, ash particles may become attached to the face of the catalyst. These may be seen while the catalyst is in the glowing stage, or when the fire is out. Any deposit on the visible face of the catalyst should be removed. Wait until the fire is out and the stove is cold. (Hot ash in a vacuum cleaner bag will burn.)

Brushing the catalyst with a soft bristle paint brush will remove some deposits. Passing a plastic vacuum cleaner wand or brush near the face of the catalyst will remove most deposits. Never scrape the catalyst with any hard tool or brush. Some stove owners have run pipe cleaner through every individual cell of the catalyst. This is not needed, and may actually do more harm than good. Limit cleaning to the face of the catalyst.

For more thorough cleaning see page 46-48 of this manual.

**Note:** Never remove a combustor without approved combustor gasket in hand as original gasket will fall apart when removed from stove.

**TIP:** A nice hot fire will usually prove to be the best method of cleaning the combustor of deposits.

# Maintenance

## CATALYTIC COMBUSTOR, REPLACEMENT

The catalytic thermometer on top of the stove should read in the active zone after the stove has been in operation for several hours. If the thermometer's indicator needle does not stay above the 1/3 mark in the active zone, even with a hot fire, over a 7-10 day period of regular use, the catalyst may need replacement. If the combustor must be examined or replaced, follow this procedure:

1. Allow the stove to burn out and cool down.
2. Open the door and remove the flame shield - the perforated plate that is just above the inside of the door opening. Lift it slightly and pull it forward and down.
3. The combustor may now be seen. The combustor is held together by a stainless steel band. Use a screwdriver and gently pry under the band at each end. The combustor will loosen enough that it can be pulled forward, lowered and out through the door.
4. The insulating material around the stainless band will probably disintegrate as the combustor is removed. If the combustor is placed back in the stove, the insulating material **MUST** be replaced. Obtain a piece 2" x 30" from your dealer. When installing the insulation, ensure the ends are butted closely together.
5. Do not burn the stove with the combustor removed, or without the insulation around the combustor.
6. To replace the combustor, first clean the combustor seat and the area around it. Also take this opportunity to clean the area around the by-pass -- use a vacuum cleaner.
7. Lift the new combustor into position, with the stainless flanges on each end and the bottom. The combustor should easily slide into position, as far to the back of the stove as possible. Don't be concerned if it appears a bit loose. The insulation around the outside of the stainless band will expand during the first fire and will hold the combustor in.
8. Replace the flame shield (the Perforated plate) by holding it inside the firebox with the triangular wings facing away from you. Lift it into position, between the door and the catalyst, and rest the bottom of the plate on the two pins that protrude below the catalyst. The flame shield should rest at an angle (about 45 degrees) with its bottom near the combustor, and its top near the stove front.

## DOOR GLASS, CLEANING

The best -way to keep the glass clean is to leave the stove on high burn for a period of time after each reloading. The moisture which is driven from a new load of wood contributes much of the creosote on the inside of the glass. Removing that moisture at the beginning of the burn cycle helps to keep the glass clean. Leaving the thermostat on a higher setting for 30 minutes to an hour before turning to low for an overnight burn will also help. Even then the glass may coat during a low burn. Heavier deposits may require hand cleaning. Manual glass cleaning should be done when the stove and glass are cool. **DO NOT CLEAN THE GLASS WHILE IT IS HOT.** Use a soft cloth and a **NONABRASIVE** household cleaner. After using any cleaner, thoroughly rinse the glass with water to remove any deposits left by the cleaner. Failure to remove all traces of glass cleaner will result in the glass cleaner residue baking on. This residue may be very difficult to remove.

## DOOR GLASS, REPLACEMENT

Your BLAZE KING is equipped with a door which uses a strong, heat-resistant ceramic glass intended to withstand extremely high temperatures and tested for continuous use above 1200 degrees Fahrenheit. However, this glass can be broken through improper use. If glass replacement becomes necessary, use only **BLAZE KING GLASS**. **DO NOT SUBSTITUTE ANY OTHER MATERIAL FOR THIS PURPOSE.**

### WARNING

**BROKEN DOOR GLASS IS SHARP. ALWAYS WEAR EYE PROTECTION AND PROTECTIVE GLOVES WHEN HANDLING GLASS. DISCARD THE GLASS IN A CLOSED CONTAINER INACCESSIBLE TO CHILDREN.**

1. Allow the fire to completely burn out and the stove to cool down.
2. Retain all metal parts for re-installation.
3. Open the door and remove the door gasket, then remove the nuts holding the retainers to the inside of the door.
4. Remove the damaged glass and the old glass gasket.
5. The replacement glass has the gasket installed on its outer perimeter. Place the glass in the door frame. Be sure the words "Blaze King" etched in the glass read correctly when the door is closed.
6. Replace the gasket and reinstall the retainers with the proper nuts.

## CHIMNEY DRAFTS

If you suspect a draft problem in an existing chimney, determine the draft by using a water manometer (draft gauge). The draft should be measured with the stove at medium burn. After the measurement is completed, fill any holes that were made in the chimney connector by using a sheet metal screw of proper size. The draft should measure .02" or above. Drafts below .02" will cause excessive smoke spillage, incomplete combustion and fire start-up problems.

# Maintenance

## OPTIONAL FAN ASSEMBLY

Routine maintenance of the OPTIONAL Fan Assembly on the back of the stove is not required. However, should it become necessary to replace an individual fan from your local dealer.

## PAINT

If the finish on the stove ever becomes blemished, you can repaint with high temperature paint available from your dealer. DO NOT paint the stove while it is HOT.

## RHEOSTAT REPLACEMENT

The fan rheostat seldom fails. But, if it does, follow this procedure after obtaining a BLAZE KING replacement rheostat.

1. Unplug the fan power cord from the wall.
2. Remove the four screws on the fan cage containing the rheostat switch.
3. Remove the blower from the cage, DO NOT DISCONNECT THE WIRES; locate the two wires coming from the rheostat switch.
4. Unplug the two wires from the rheostat switch.
5. Pull the knob straight off the switch.
6. Unscrew the nut holding the switch to the cage.
7. Replace the switch, making sure the small position locating pin is fitted into the hole in the cage.
8. To reinstall the switch, reverse the above steps being sure to tuck the wires back into the assembly so they do not come in contact with the fan blade.

## THERMOMETER

The catalyst thermometer, with its built-in lag of 4-8 minutes, tells you what was happening 4-8 minutes ago. And remember, it is only an indication of the temperatures of the gasses, after they pass through the catalyst. The thermometer probe, the part that fits into the stove, must be cleaned at least once a year. Lift it from the stove (be careful, it may be hot) and wipe or scrape it clean. At room temperature, away from the stove, the indicator should point near the bottom of the "Inactive" zone. If, after several years use, you find that the needle no longer points to the bottom of the "Inactive" zone when the thermometer has been at room temperature for 10 minutes or longer, it may need adjustment. Holding the probe with a pair of pliers, loosen the bolt on the top of the dial. Turn the dial to align the pointer with the bottom of the "Inactive" zone, then retighten the bolt.

**Note:** If your Blaze King is equipped with optional fans, turn off fans and wait 10 minutes prior to reading catalytic thermometer indicator. Air movement across the top of the stove may provide false reading.

## THERMOSTAT

Under normal operations, the thermostat should be set on a mid-range setting. At this setting the stove is capable of heating an average size home. The thermostat is adjusted at the factory and should not be tampered with. If the thermostat breaks, the damper will automatically close.

# Troubleshooting

Your Blaze King is designed to allow a wide selection of heat output levels. If you begin to lose control of the amount of heat the stove is emitting, determine the cause early so that major problems may be avoided.

The six major needs of a well-controlled fire are:

1. Knowledgeable, interested operator.
2. Adequate air supply.
3. Firewood of good quality and proper size.
4. Catalytic combustor in good condition.
5. Clean chimney, properly sized and installed.
6. Door gasket tight and firm.

Considering all of the above, number one is the most important for safe and efficient operation of any woodstove. Please study the operation instructions carefully. Consult your BLAZE KING dealer call the Customer Service Department at Blaze King in the U.S.A. at 509-522-2730 or in Canada at 250-493-7444 if you have any questions not answered in this manual.

All of the six above mentioned needs are interrelated. A deficiency in any one will affect all of the others. If you encounter a problem, determine the source of the problem and then follow-up by checking the other needs as possible contributing factors.

## **PROBLEM: Chimney Fire**

### **CAUSE**

Act immediately regardless of cause

### **SOLUTION**

Turn the thermostat to lowest setting, check loading door to be sure it is tightly closed.

**Call Fire Department.**

After the fire is out, have your chimney and flue connector inspected by a certified chimney sweep. A damaged masonry chimney should be repaired or rebuilt. A prefabricated chimney (factory built) that is damaged should be replaced. Any damage to the flue connector should be corrected before the system is used again.

Possible causes of a chimney fire, and remedies for those causes, can be found further in this section: "Excessive Creosote Formation", and "Spots of Creosote Accumulation in Chimney or Flue Connector".

## **PROBLEM: Not enough heat.**

### **CAUSE**

Green or wet wood.

Not enough fuel in stove.

### **SOLUTION**

Use seasoned wood. Don't be afraid to FULLY load the stove. A FULL load of wood won't burn any hotter than the thermostat is set.

Obstruction in chimney or cap screen.

Combustor plugged or coated.

Remove obstruction. Test combustor, page 36

Clean combustor, page 36

Combustor not functioning.

Test combustor, page 36

If needed, replace combustor, page 37

Thermostat set too low.

Raise thermostat setting.

Thermostat not operating properly.

Consult your Blaze King dealer.

Poor draft caused by an oversize flue

Measure draft with Manometer.

See CHIMNEY DRAFTS, page 37

See CHIMNEY, page 8

Consult your Blaze King dealer or a chimney sweep

Strong, gusting winds causing downdraft in chimney

Install wind-resistant chimney cap. Directional caps may not stay freely rotating If you have a directional cap, check it frequently

Tightly sealed house, inadequate air supply

Open a window, slightly, near the stove or install an outside air kit.

Reloading too much wood on top of too few coals.

Allow a larger bed of coals to build up.



# Troubleshooting

**PROBLEM: Too much heat.****CAUSE**

By-Pass door left open.

Thermostat set too high.

Loading door gasket leaking, admitting excess air into firebox.

Excessive draft in the chimney.

Thermostat not operating properly

Wood is too small.

**SOLUTION**

Close the by-pass door.

Lower thermostat setting.

Replace door gasket and/or adjust door, page 35.

Measure draft with a Manometer  
See DRAFTS, page 38 Consult your Blaze King dealer or a chimney sweep. Install a cap.

Consult your Blaze King dealer.

Use larger pieces.

**PROBLEM: One or both fans will not run, or there is no adjustment for fan speed.****CAUSE**

Fans mounted improperly.

Fan speed control.

**SOLUTION**

Check that fan blade's not touch edges of hole.

Consult your Blaze King dealer. For replacement, see Rheostat Replacement, page 38

**PROBLEM: Fans minimum speed too fast or maximum speed too slow.****CAUSE**

Fan speed control out of adjustment.

**SOLUTION**

Consult your Blaze King Dealer.

**PROBLEM: Excessive creosote formation in chimney and chimney Connector.****CAUSE**

By-pass door left open

By-pass door not sealing tightly

Improper operation.

Wood too green or wet.

Catalytic combustor not operating properly.

Poor draft caused by an oversize or short flue, etc

Chimney too cold or poorly insulated.

**SOLUTION**

Close by-pass door.

Inspect by-pass door and seal for warping. Ash or creosote buildup may occur on door or seat. With stove cold scrape and vacuum area around by-pass. Be sure all mating steel surfaces are clean and smooth.

Check thermostat setting and operating procedures, page 33

Use seasoned wood.

Inspect the combustor.  
See catalytic combustor testing, page 36

Measure draft with Manometer. See DRAFTS, page 38  
See CHIMNEY, page 8  
Consult your Blaze King dealer or a chimney sweep.

Upgrade chimney system.  
Consult your Blaze King dealer or a chimney sweep.

**PROBLEM: Catalytic combustor thermometer (on top of stove) does not go into "Active" zone, or does not stay there for long.****CAUSE**

Improper operation

Obstruction in chimney or cap

Faulty catalyst thermometer.

**SOLUTION**

Check thermostat setting And operating procedures.  
See page 33

Clean chimney, remove Obstructions.

Replace thermometer and Recheck combustor operating Temperature.

# Troubleshooting

*continued from page 40...*

Wood too green or wet.

Use seasoned wood.

Combustor plugged or coated.

Clean combustor, see Page 36

Combustor not functioning.

Check and test combustor  
If needed replace combustor. See page 37

Thermostat not operating properly.

Consult your blaze King Dealer.

By-pass door leaking or not closing completely.

Inspect and clean area around by-pass doors.  
Adjust or repair as necessary. Consult your  
Blaze King Dealer.

## **PROBLEM: Spots of creosote accumulation in chimney or chimney connector.**

### **CAUSE**

Air leaks in chimney or chimney connector.

### **SOLUTION**

Inspect chimney and/or chimney connector. Repair or replace as necessary Check to be sure that the chimney connector is installed correctly.

***CAUTION: a leaking chimney connector is a fire hazard and demands immediate attention.***

Poor draft caused by an oversize flue, etc.

Measure draft with Manometer.  
See DRAFTS, page 38.  
See CHIMNEY, page 8  
Consult your Blaze King dealer or a chimney sweep.

## **PROBLEM: Door glass quickly becomes coated with creosote.**

### **CAUSE**

Low thermostat setting or lowering the thermostat setting too far, too quickly.

### **SOLUTION**

Turn the thermostat to the warmest setting during the first 20-30 minutes or until the fire is well established after each reloading.

Poor draft caused by an oversize or short flue, etc.

Measure draft with Manometer.  
See DRAFTS, page 38. See CHIMNEY, page 8.  
Consult your Blaze King dealer or a chimney sweep.

Obstruction in chimney or cap screen.

Remove obstruction. Clean chimney and/or cap screen.

Strong, gusting winds causing downdraft in chimney.

Install wind-resistant chimney cap.

Tightly sealed house, inadequate air supply.

Open a window, slightly, near the stove.

Burning poorly seasoned wet wood, or wood with high pitch content,

Use seasoned wood with low pitch content.  
such as some types of pine.

## **PROBLEM: The catalyst temperature cannot be controlled. Turning the thermostat down often makes the catalyst temperature go up.**

### **CAUSE**

Turning the thermostat down, particularly in the first half of the burn cycle, causes the fire to emit more smoke, which is fuel for the catalyst. The catalyst temperature therefore climbs for up to several hours. This is normal, and is of no concern. As long as only the catalyst temperature is elevated, there is nothing to worry about.

## **PROBLEM: Smoke spills from door opening when loading fuel**

### **CAUSE**

Spark arrestor screen plugged

### **SOLUTION**

Clean spark arrestor screen to bare metal wire

Chimney too cold

Make certain double wall stove pipe is used in installation

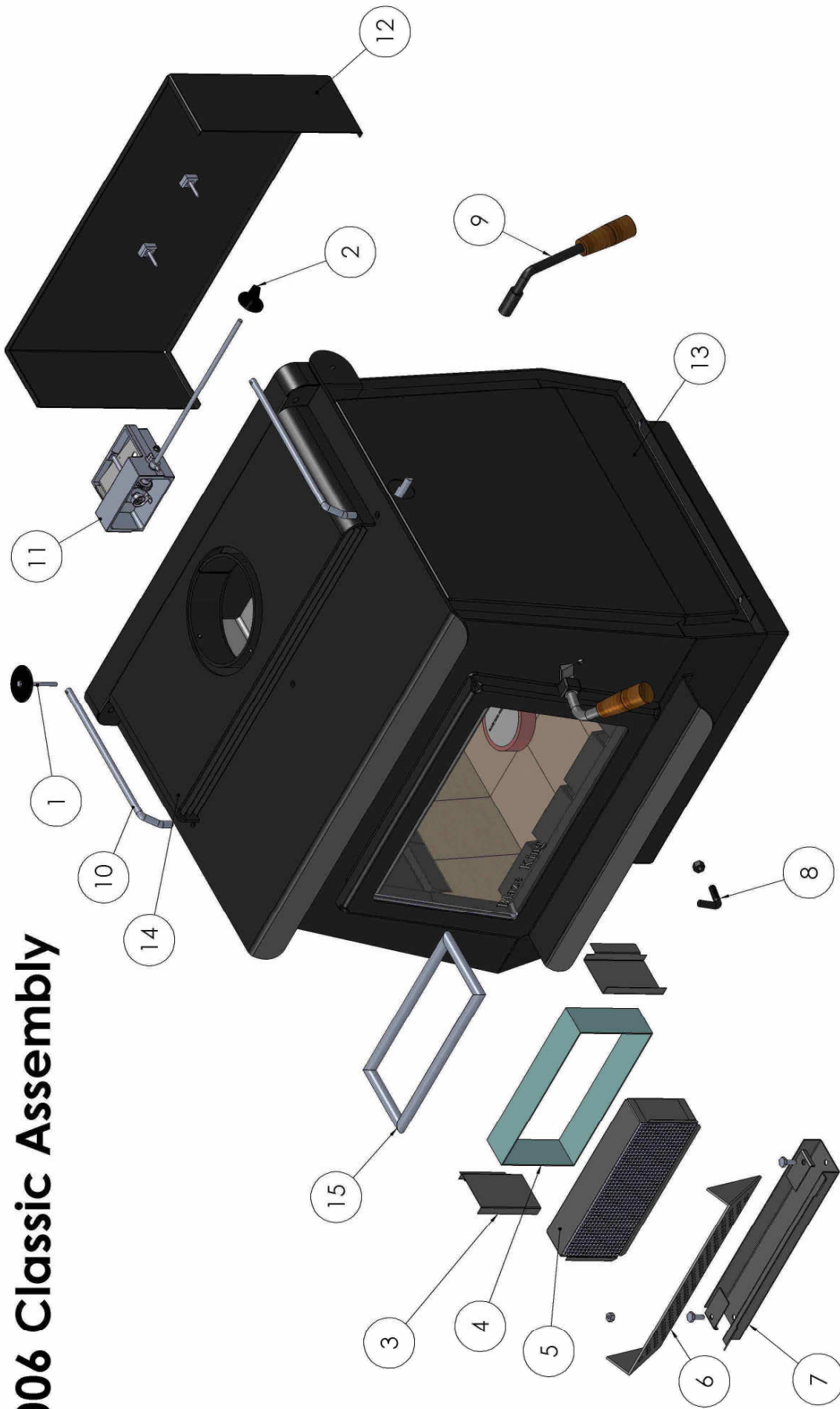
Not enough vertical rise

Make certain a minimum vertical rise of 36" is observed prior to elbows. Use two 45 elbows instead of 90 elbow.

Chimney not drafting

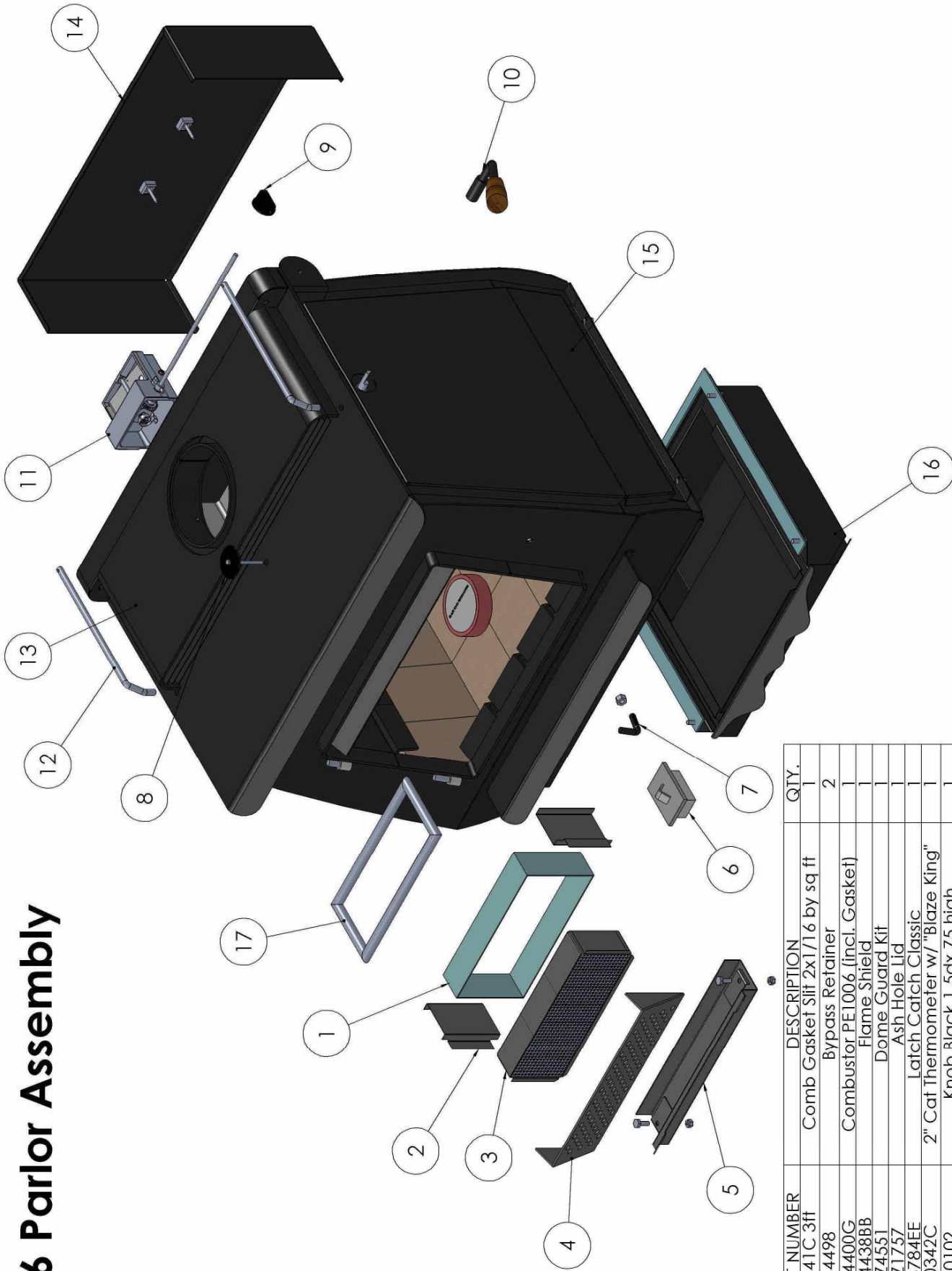
Turn thermostat to highest setting, open bypass, leave loading door closed and wait 5-10 minutes to increase chimney or flue temperature.

# PE1006 Classic Assembly



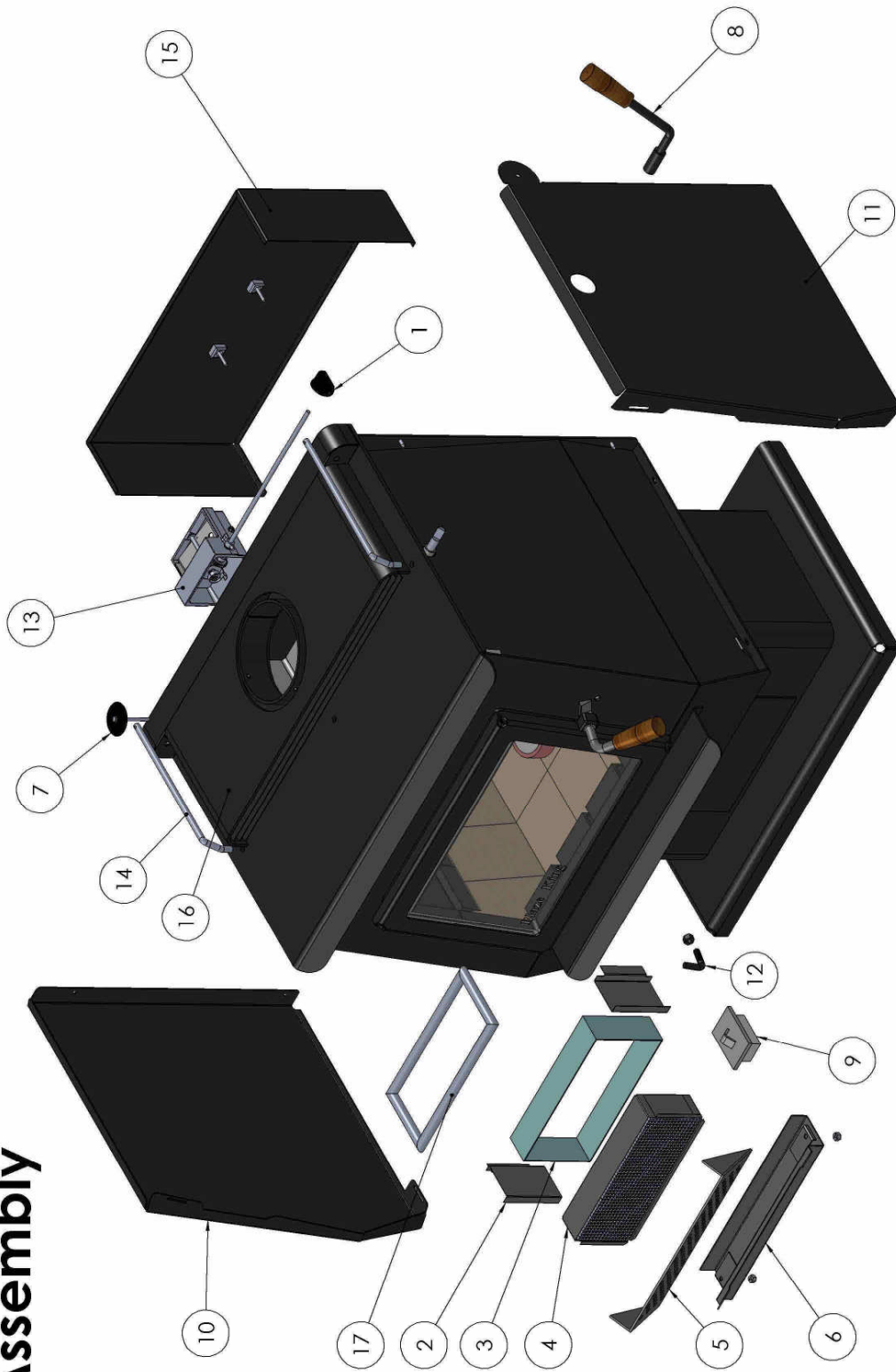
| ITEM NO. | PART NUMBER | DESCRIPTION                           | QTY. |
|----------|-------------|---------------------------------------|------|
| 1        | 0342C       | 2" Cat Thermometer w/ "Blaze King"    | 1    |
| 2        | 0102        | Knob Black 1.5dx.75 high              | 1    |
| 3        | 4498        | Bypass Retainer                       | 2    |
| 4        | 0341C 3ft.  | Comb Gasket Slit 2x1/16 by sq ft      | 1    |
| 5        | Z4400G      | Combustor PE1006 (incl. gasket)       | 1    |
| 6        | Z4438BB     | Flame Shield                          | 1    |
| 7        | Z4551       | Dome Guard Kit                        | 1    |
| 8        | 5784EE      | Latch Catch Classic                   | 1    |
| 9        | Z4467       | Bypass Handle                         | 1    |
| 10       | Z4460       | Top Rail Assembly PE/KE               | 1    |
| 11       | Z3005C      | Thermostat PE1006                     | 1    |
| 12       | R/SP1006    | Rearshield Kit                        | 1    |
| 13       | S/SP1006    | Side shield Kit                       | 1    |
| 14       | Z1744       | Convection Deck                       | 1    |
| 15       | 0255B 3ft   | Bypass Gasket 5/8 Dense Rnd Blk pr ft | 1    |

# PE1006 Parlor Assembly



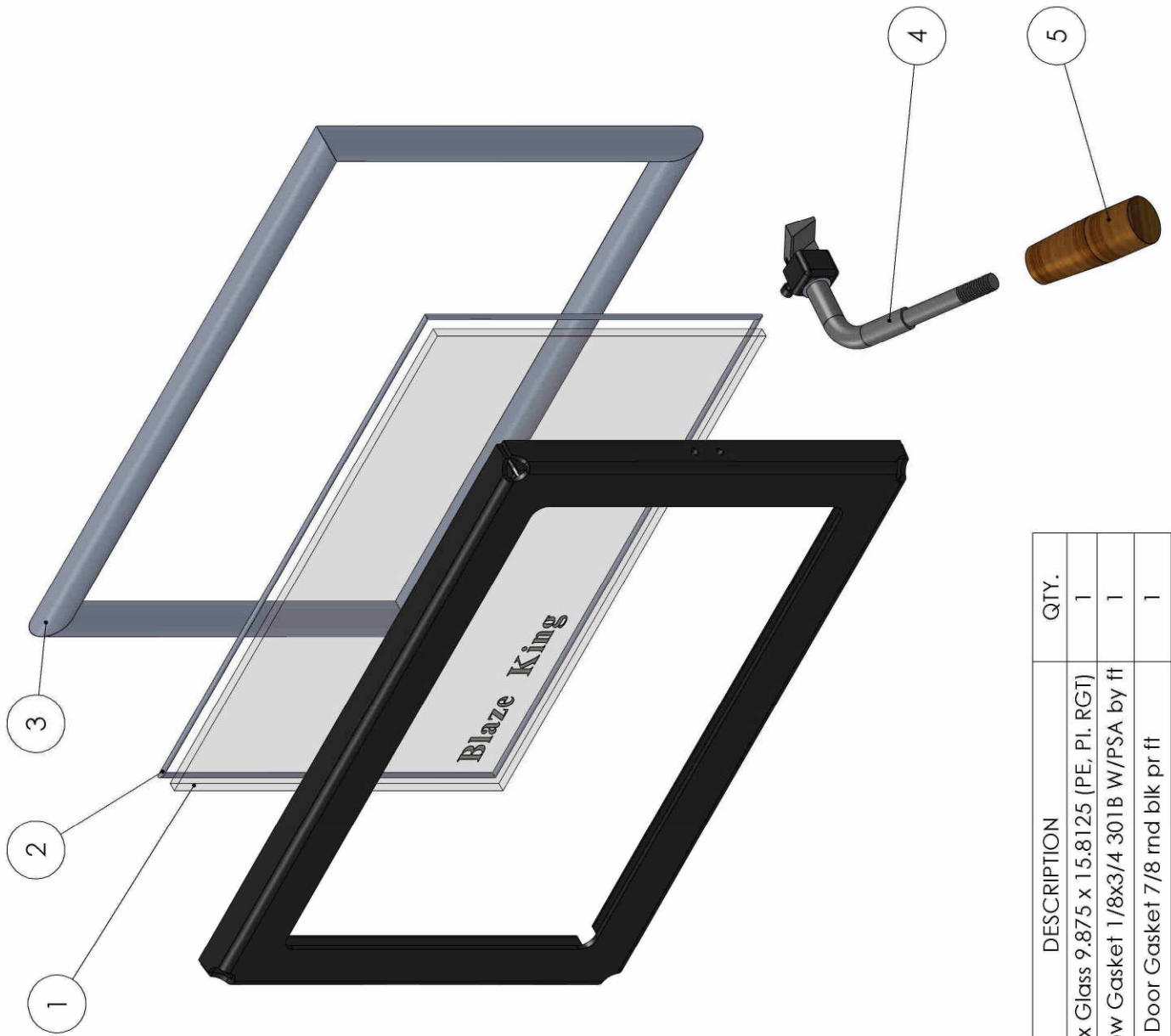
| ITEM NO. | PART NUMBER | DESCRIPTION                           | QTY. |
|----------|-------------|---------------------------------------|------|
| 1        | 0341C 3ft   | Comb Gasket Slit 2x1/16 by sq ft      | 1    |
| 2        | 4498        | Bypass Retainer                       | 2    |
| 3        | Z4400G      | Combustor PE1006 (incl. Gasket)       | 1    |
| 4        | Z4438BB     | Flame Shield                          | 1    |
| 5        | Z4551       | Dome Guard Kit                        | 1    |
| 6        | Z1757       | Ash Hole Lid                          | 1    |
| 7        | 5784EE      | Latch Catch Classic                   | 1    |
| 8        | 0342C       | 2\" Cat Thermometer w/ \"Blaze King\" | 1    |
| 9        | 0102        | Knob Black 1.5dx.75 high              | 1    |
| 10       | Z4467       | Bypass Handle                         | 1    |
| 11       | Z3005C      | Princess Thermostat                   | 1    |
| 12       | Z4460       | Top Rail Assembly PE/KE               | 1    |
| 13       | Z1744       | Convection Deck                       | 1    |
| 14       | R/SP1006    | Rear Shield Kit                       | 1    |
| 15       | S/SP1006    | Side Shield Kit                       | 1    |
| 16       | Z1710       | Ash Drawer Kit                        | 1    |
| 17       | 0255B 3ft   | Bypass Gasket 5/8 Dense Rnd Blk pr ft | 1    |

# PE1006 Ultra Assembly



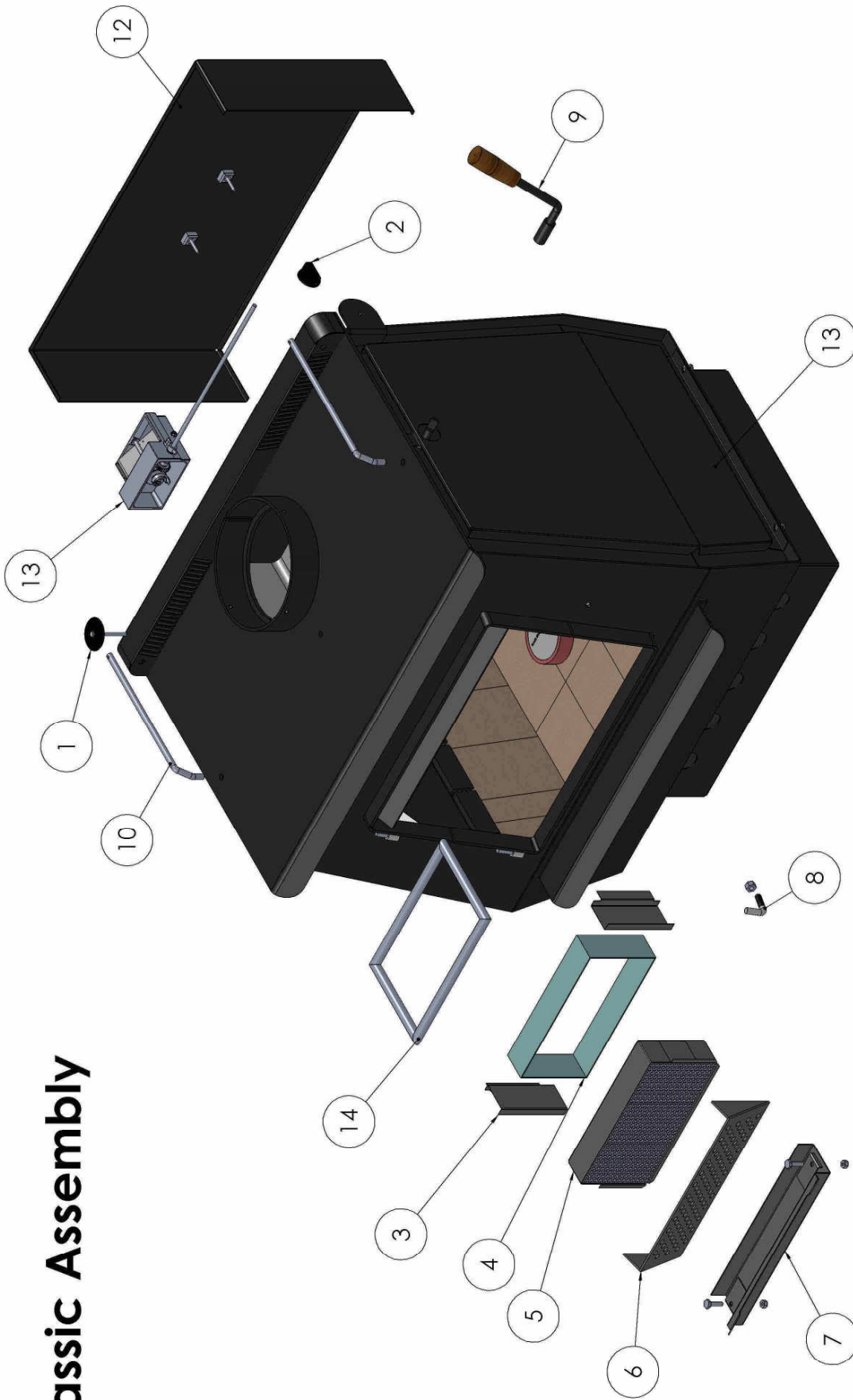
| ITEM NO. | PART NUMBER | DESCRIPTION                           | QTY. |
|----------|-------------|---------------------------------------|------|
| 1        | 0102        | Knob Black 1.5dx.75 high              | 1    |
| 2        | 4498        | Bypass Retainer                       | 2    |
| 3        | 0341C 3ft.  | Comb Gasket Slit 2x1/16 by sq ft      | 1    |
| 4        | Z4400G      | Combustor PE1006                      | 1    |
| 5        | Z4438BB     | Flame Shield                          | 1    |
| 6        | Z4551       | Dome Guard Kit                        | 1    |
| 7        | 0342C       | 2" Cat Thermometer w/ "Blaze King"    | 1    |
| 8        | Z4467       | Bypass Handle                         | 1    |
| 9        | Z1757       | Ash Hole Lid                          | 1    |
| 10       | 4476L       | Side Shield Ultra Left                | 1    |
| 11       | 4476R       | Side Shield Ultra Right               | 1    |
| 12       | 5784EE      | Latch Catch Classic                   | 1    |
| 13       | Z3005D      | Princess Ultra Thermostat             | 1    |
| 14       | Z4460       | Top Rail Assembly PE/KE               | 1    |
| 15       | R/SP1006    | Rear Shield Kit                       | 1    |
| 16       | Z1744       | Convection Deck                       | 1    |
| 17       | 0255B 3ft   | Bypass Gasket 5/8 Dense Rnd Blk pr ft | 1    |

# PE1006 Door Assembly



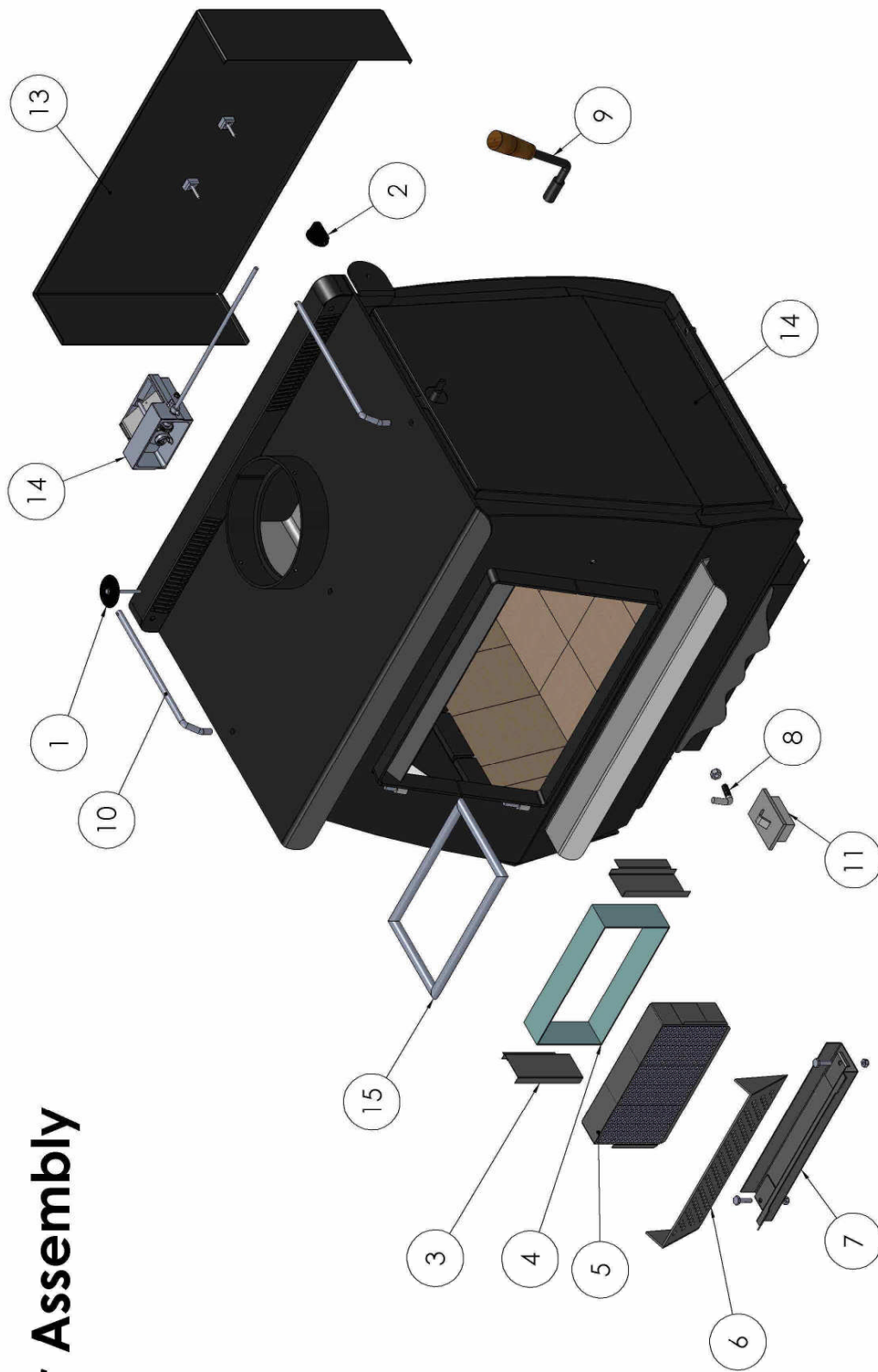
| ITEM NO. | PART NUMBER | DESCRIPTION                               | QTY. |
|----------|-------------|---|------|
| 1        | 0246        | Robax Glass 9.875 x 15.8125 (PE, Pl. RGT) | 1    |
| 2        | 0254AS      | Window Gasket 1/8x3/4 301B W/PSA by ft    | 1    |
| 3        | 0186-6ft    | Door Gasket 7/8 rnd blk pr ft             | 1    |
| 4        | Z5785       | Handle Assembly (incl. latch)             | 1    |
| 5        | 0121A       | Wood Handle 3 3/8 x 1 1/4                 | 1    |

# KE Classic Assembly



| ITEM NO. | PART NUMBER | DESCRIPTION                           | QTY. |
|----------|-------------|---------------------------------------|------|
| 1        | 0342C       | 2" Cat Thermometer w/ "Blaze King"    | 1    |
| 2        | 0102        | Knob Black 1.5dx.75 high              | 1    |
| 3        | 4598        | Bypass Retainer                       | 2    |
| 4        | 0341 C 3ft  | Comb Gasket Slit 2x1/16 by sq ft      | 1    |
| 5        | Z4500F      | Combustor KE1107 (incl. Gasket)       | 1    |
| 6        | Z4438BB     | Flame Shield                          | 1    |
| 7        | Z4551       | Dome Guard Kit                        | 1    |
| 8        | 5784EE      | Latch Catch Classic                   | 1    |
| 9        | Z4467       | Bypass Handle                         | 1    |
| 10       | Z4460       | Top Rail Assembly PE/KE               | 1    |
| 11       | R/S1107     | Rearshield Kit                        | 1    |
| 12       | S/SK1107    | Side Shield Kit                       | 1    |
| 13       | Z3007       | King Thermostat (Class & Parlor)      | 1    |
| 14       | 0255B 3ft   | Bypass Gasket 5/8 Dense Rnd Blk pr ft | 1    |

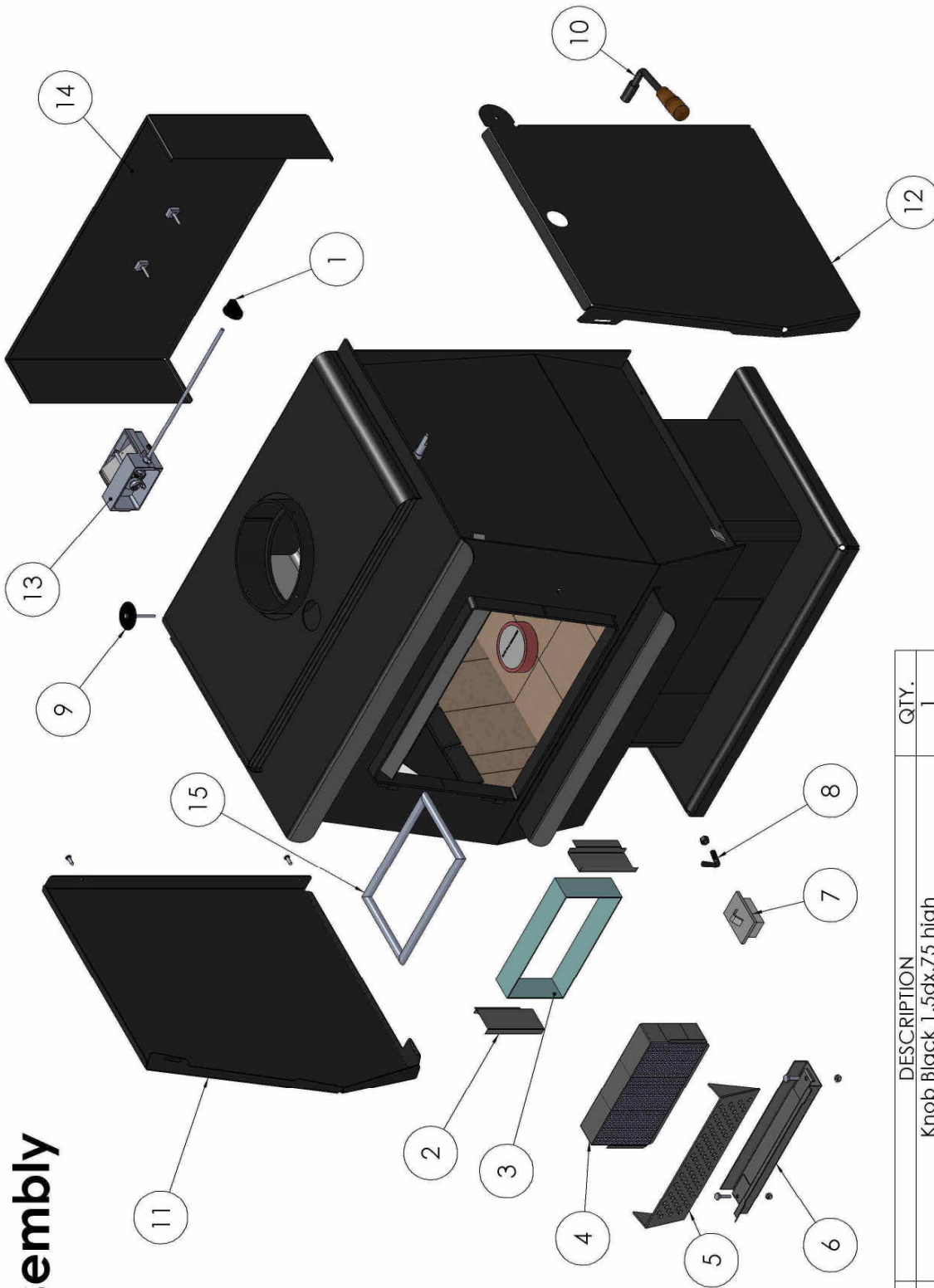
# King Parlor Assembly



| ITEM NO. | PART NUMBER | DESCRIPTION                           | QTY. |
|----------|-------------|---------------------------------------|------|
| 1        | 0342C       | 2" Cat Thermometer w/ "Blaze King"    | 1    |
| 2        | 0102        | Knob Black 1.5dx.75 high              | 1    |
| 3        | 4598        | Bypass Retainer                       | 2    |
| 4        | 0341C 3 ft. | Comb Gasket Slit 2x1/16 by sq ft      | 1    |
| 5        | Z4500F      | Combustor KE1107 (Incl. Gasket)       | 1    |
| 6        | Z4438BB     | Flame Shield                          | 1    |
| 7        | Z4551       | Dome Guard Kit                        | 1    |
| 8        | 5784EE      | Latch Catch Classic                   | 1    |
| 9        | Z4467       | Bypass Handle                         | 1    |
| 10       | Z4460       | Top Rail Assembly PE/KE               | 1    |
| 11       | Z1757       | Ash Hole Lid                          | 1    |
| 12       | R/S1107     | Rear Shield Kit                       | 1    |
| 13       | S/SK1107    | Side Shield Kit                       | 1    |
| 14       | Z3007       | King Parlor Thermostat                | 1    |
| 15       | 0255B 3ft   | Bypass Gasket 5/8 Dense Rnd Blk pr ft | 1    |

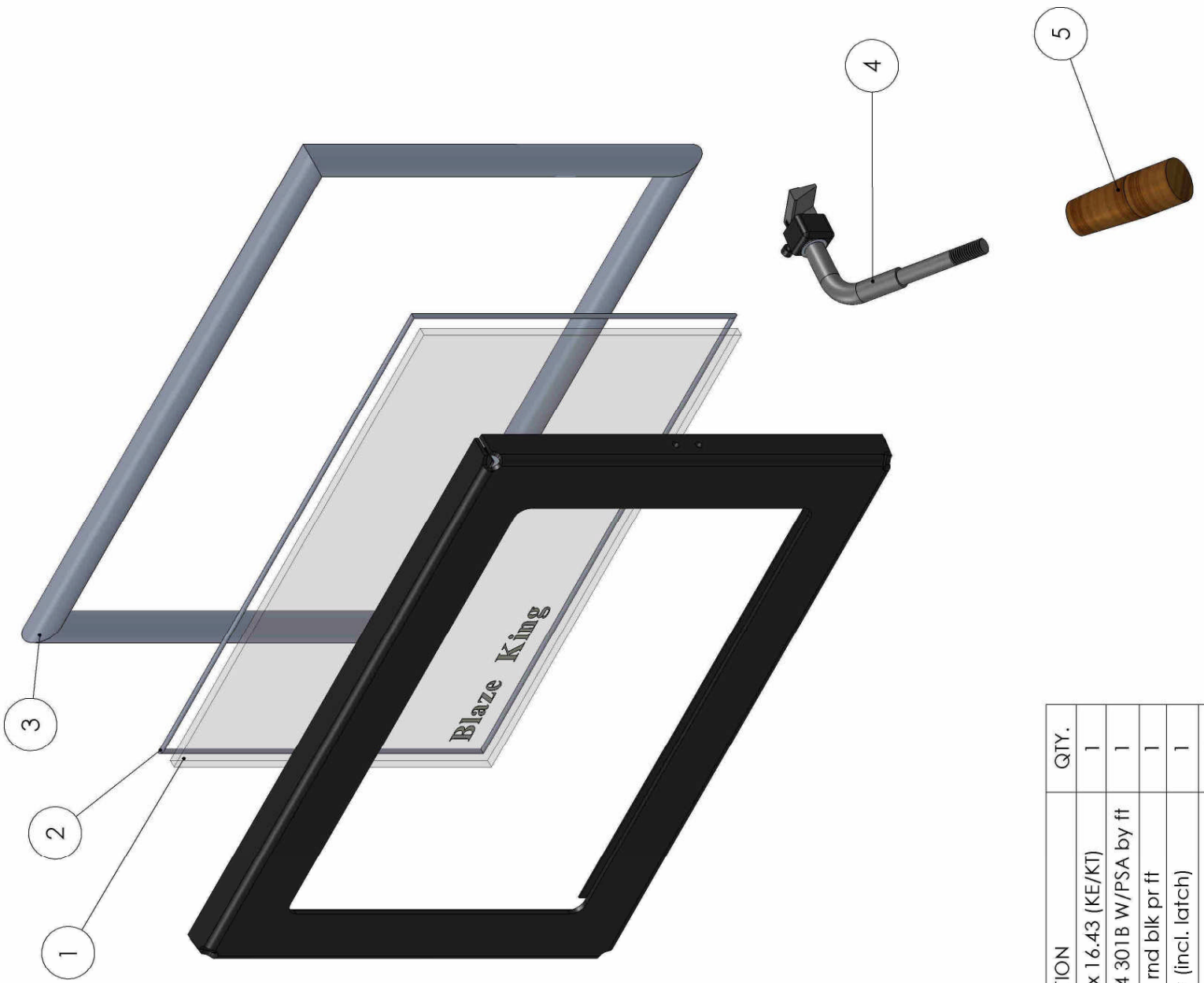


# King Ultra Assembly



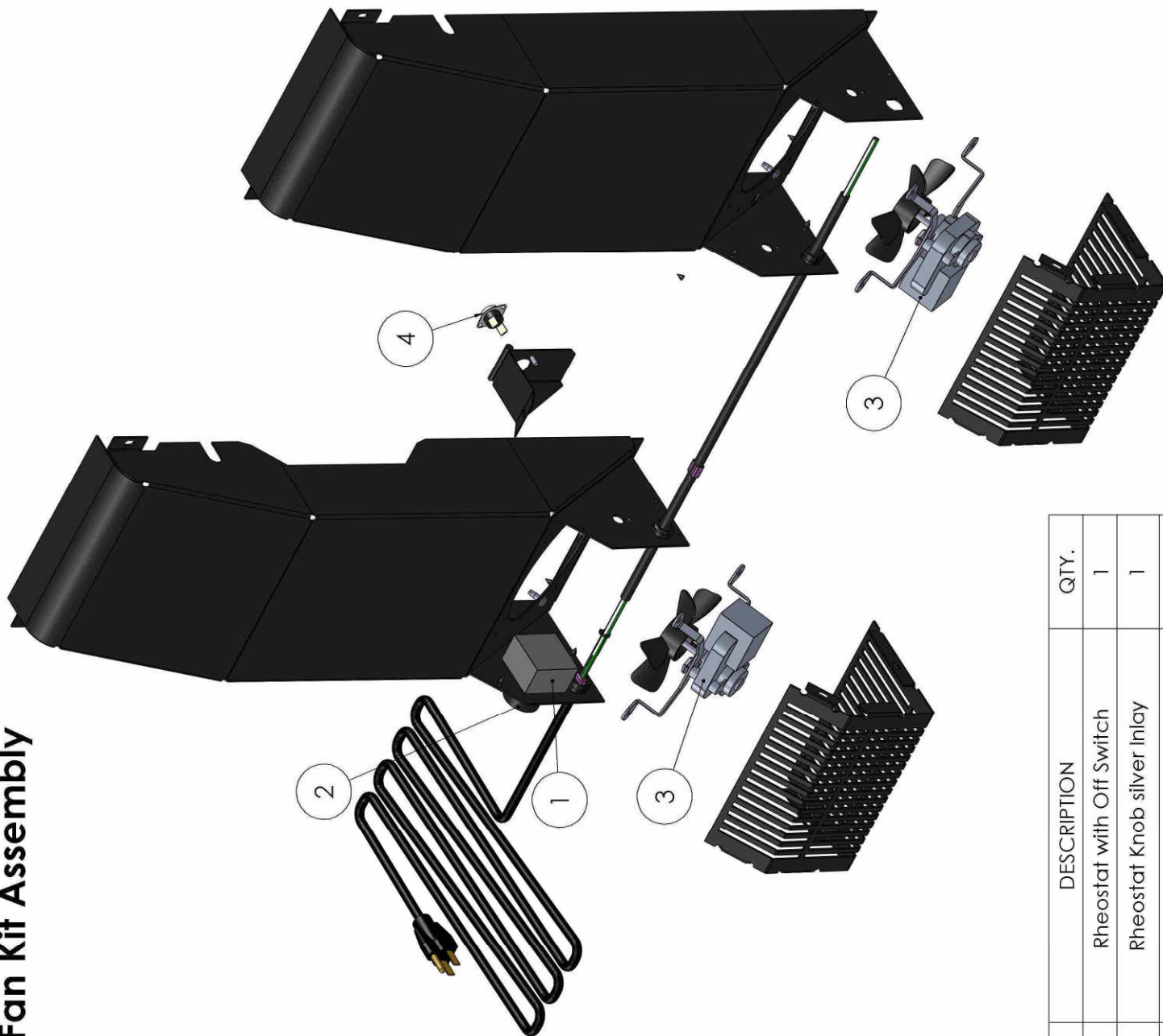
| ITEM NO. | PART NUMBER | DESCRIPTION                           | QTY. |
|----------|-------------|---------------------------------------|------|
| 1        | 0102        | Knob Black 1.5dx.75 high              | 1    |
| 2        | 4598        | Bypass Retainer                       | 2    |
| 3        | 0341C 3ft   | Comb Gasket Slit 2x1/16 by sq ft      | 1    |
| 4        | Z4500F      | Combustor KE1107 (Incl. Gasket)       | 1    |
| 5        | Z4438BB     | Flame Shield                          | 1    |
| 6        | Z4551       | Dome Guard Kit                        | 1    |
| 7        | Z1757       | Ash Hole Lid                          | 1    |
| 8        | 5784EE      | Latch Catch                           | 1    |
| 9        | 0342C       | 2" Cat Thermometer w/ "Blaze King"    | 1    |
| 10       | Z4467BB     | Bypass Handle                         | 1    |
| 11       | 4776L       | Side Shield KE Ultra Left             | 1    |
| 12       | 4776R       | Side Shield KE Ultra Right            | 1    |
| 13       | Z3007U      | King Ultra Thermostat                 | 1    |
| 14       | R/S1107     | KE Rear Shield Kit                    | 1    |
| 15       | 0255B 3ft   | Bypass Gasket 5/8 Dense Rnd Blk pr ft | 1    |

# KE1107 Door Assembly



| ITEM NO. | PART NUMBER | DESCRIPTION                            | QTY. |
|----------|-------------|--|------|
| 1        | 0250        | Robax Glass 10.43 x 16.43 (KE/KT)      | 1    |
| 2        | 0254AM-8FT  | Window Gasket 1/8x3/4 301B W/PSA by ft | 1    |
| 3        | 0186-8ft    | Door Gasket 7/8 md blk pr ft           | 1    |
| 4        | Z5785       | Handle assembly (incl. latch)          | 1    |
| 5        | 0121A       | Wood Handle 3/8 x 1 1/4                | 1    |

# PE1006 / KE1107 Fan Kit Assembly



| ITEM NO. | PART NUMBER | DESCRIPTION                          | QTY. |
|----------|-------------|--------------------------------------|------|
| 1        | 0136        | Rheostat with Off Switch             | 1    |
| 2        | 0137        | Rheostat Knob silver Inlay           | 1    |
| 3        | 0175C       | Fan Axial Spider mnt Muffin (Bay)    | 2    |
| 4        | 1142A       | Snap Disk F100 Sensor/Klixon Classic | 1    |

# Addendum—Your First Fire

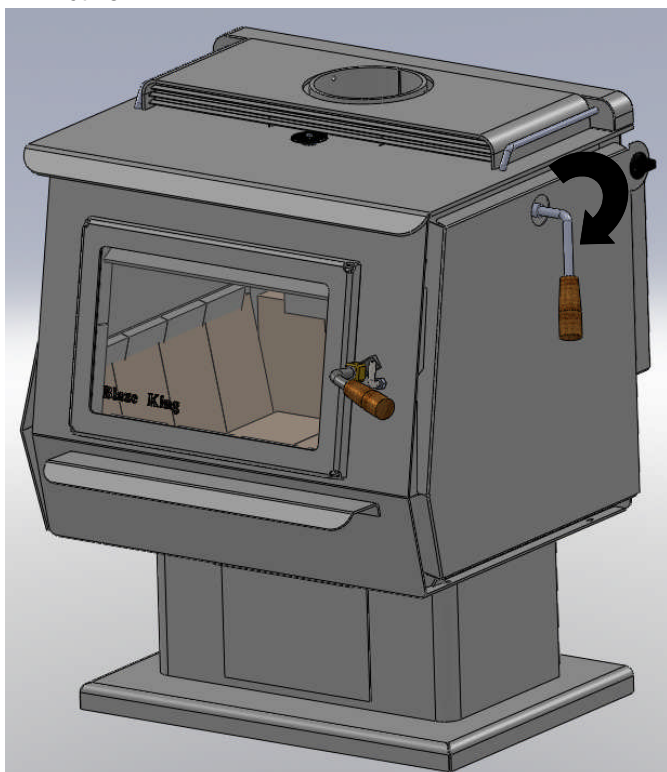
## Your First Fire!

Forget everything you ever learned about how to burn or operate a run of the mill wood stove. You now own the finest wood stove ever made and in order to get peak performance you will need to follow these steps.

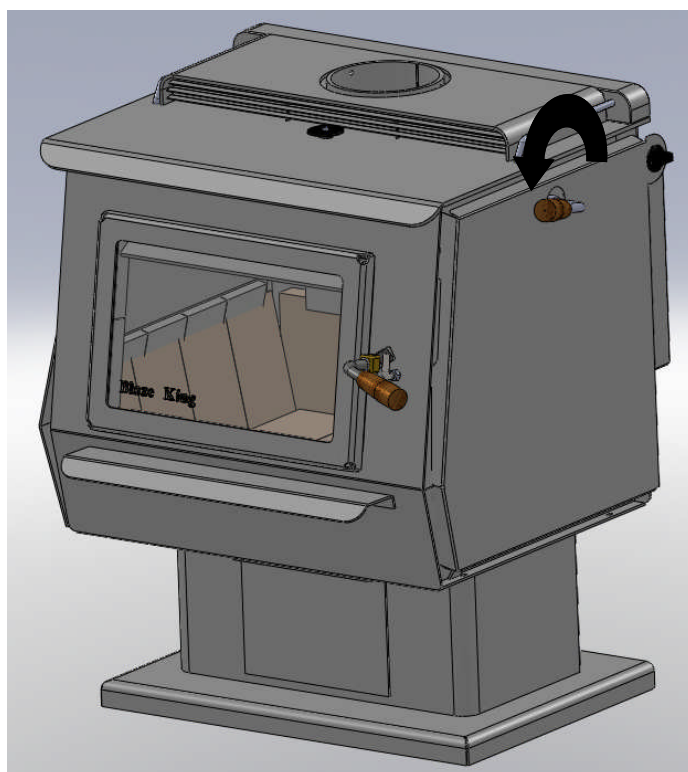
You can't just throw in some newspaper and a log or two and light a match. Your stove won't work using conventional methods such as those used when burning inefficient wood stoves. Your Blaze King is designed to give you far more heat for your time & money.

There are four control features to your new Blaze King that are instrumental in getting your first fire started.

- 1) The Thermostat located on the top right rear corner of the stove. Set the Thermostat on "High". After a bit you can adjust the thermostat to your comfort zone, but for now, leave it on "High". The increased flow of air is necessary in the first few minutes of lighting your stove. It is necessary to mention that too many people make too many and rapid changes to the Thermostat. Let's say you have been using the stove on "High" when you begin to build a fire. The coils in the Thermostat are now hot and if you turn the Thermostat to "Low" right away, you can actually cause the fire to go out from such a rapid change. All changes to the Thermostat should be done gradually. When you first light the stove and you are using the "High" setting, move the Thermostat towards "Medium" at 20 minute intervals. After the stove has operated at Medium for an hour or so, then you can move towards low. The Thermostat is sensitive and must be adjusted gradually. Too rapid an adjustment will cause the stove to operate improperly. The most common mistake new owners make is fiddling with the Thermostat and making too many changes to rapidly.
- 2) The By-Pass handle. Located on the center top right side of the stove (see illustration below). This handle, when pointing towards you allows increased air flow, again essential when you first attempt to get your stove going. Once the fire is hot and a base of coals is established, go ahead and close the By-Pass (pointing down) but for now leave it up.
- 3) Front Loading Door. This is located at the front of the stove and plays a key role in successful initial firing of the stove. This is also where you can add more wood as it needed.
- 4) Catalytic Thermometer. Located in the top of the stove, this Thermometer will tell you when the Catalytic combustor is "Active".



Bypass closed



Bypass open

Before we begin, keep in mind that your new Blaze King catalytic wood stove will not burn the same as any other wood stove and you may not see any large amount of flames once you have the stove in full operation. The only time you will see a large amount of flames is when you either burn the stove on High (thermostat setting) or each time you open the By-Pass or Front Loading door when you add wood.

Your first step is to get around 5 pounds of small wood strips. About the size of Popsicle sticks and a little larger. Wrinkle-up 3-5 sheets of black & white newspaper. Lay the sticks all across the top of the paper and light the paper. At this time the Thermostat is on "High", by-pass handle is forward and the front loading door is open. Allow the sticks to begin burning then over the next few minutes (5-10) add approximately 10 pounds of wood about the size of a baseball bat handle. Now you can close the front door, or leave it slightly cracked open. You should begin to see a good fire developing. Once the baseball bat size kindling is going good, add a few (3-5) pieces of small split firewood. Again close the front door. Take notice the needle on the Catalytic Thermometer located in the top of the stove is starting to slowly move towards the "Active" zone. What this means is the combustor is now coming up to temperature and once it is "Active" and so long as you keep it in the "Active" zone by adding wood, you won't need another match all winter!

As soon as you notice that the needle is close to being in the "Active" zone, close the by-pass handle (turn to the down position). Leave the Thermostat setting on High for the next 20 minutes and your fire should be well established. Now, over the next few minutes, you can add larger and larger pieces of wood. And so long as you keep the Thermometer in the "Active" zone, there is no need to follow all these steps. Just add more wood when needed and like most Blaze King catalytic wood stove owners, do something you enjoy with all your extra time now that you don't have to add wood every hour!

#### **A couple of tips:**

Always have your next intended load of wood ready when you open the Front Loading door. Doing so will decrease the amount of time that the Front Loading Door is open, allowing for the Combustor to remain quite hot and also provide a margin of safety by not leaving the Front Loading Door open when going to retrieve wood. And always open the Front Loading Door SLOWLY. This will reduce any vacuum causing smoke from the fire box to "spill" into your room.

Another tip, always put the by-pass handle in the open, full counter clockwise, position before you open the Front Loading Door. This will decrease the chances of "spilling" smoke into the room when you open the Front Loading Door to add wood. BUT REMEMBER TO PUSH IT BACK (Closed) as soon as you have loaded your wood.

Congratulations...You now have the greatest, most efficient burning wood stove in full operation. You can now adjust the Thermostat to fit your needs. Keep in mind though you will not see any large amount of flame from this point forward. Should you burn the stove on a very low setting for extended periods of time, you may begin to see creosote deposits forming on the glass door. To remove these deposits, simply run the stove on "High" for a short time. The "High" setting will burn off most of the deposits.

Over the next several days or uses, you will find that your new Blaze King and you will be best friends. You will learn every little detail and setting necessary to achieve the optimal fire based on the type of wood you are burning, your home and of course how warm and cozy you like it inside.

Thank you again for purchasing a Blaze King catalytic wood stove. Be sure and tell your friends how you much less time and money you spent on obtaining wood for the winter because your new Blaze King uses wood so efficiently.

**PLEASE BE CERTAIN TO READ THE OWNERS & OPERATORS MANUAL THOROUGHLY.  
THESE PAGES ARE INTENDED TO HELP GET THE INITIAL FIRE GOING.  
DETAILED INSTRUCTIONS ARE PROVIDED IN THE OWNERS & OPERATORS MANUAL.**

# STOVES EQUIPPED with ASH DRAWERS

## **WARNING**

**NEVER STORE HOT ASHES IN A GARAGE OR BASEMENT. HOT ASHES WILL GENERATE CARBON MONOXIDE AND/OR FLAMMABLE GASES. THESE GASES MAY CAUSE SUFFOCATION.**

Ashes should be placed in a metal container with a tight fitting lid. The closed container of ashes should be placed on a non combustible floor or on the ground, well away from all combustible materials, pending final disposal. If the ashes are disposed of by burial in soil or otherwise locally dispersed, they should be retained in the closed container until all cinders have thoroughly cooled.

## **ASH REMOVAL**

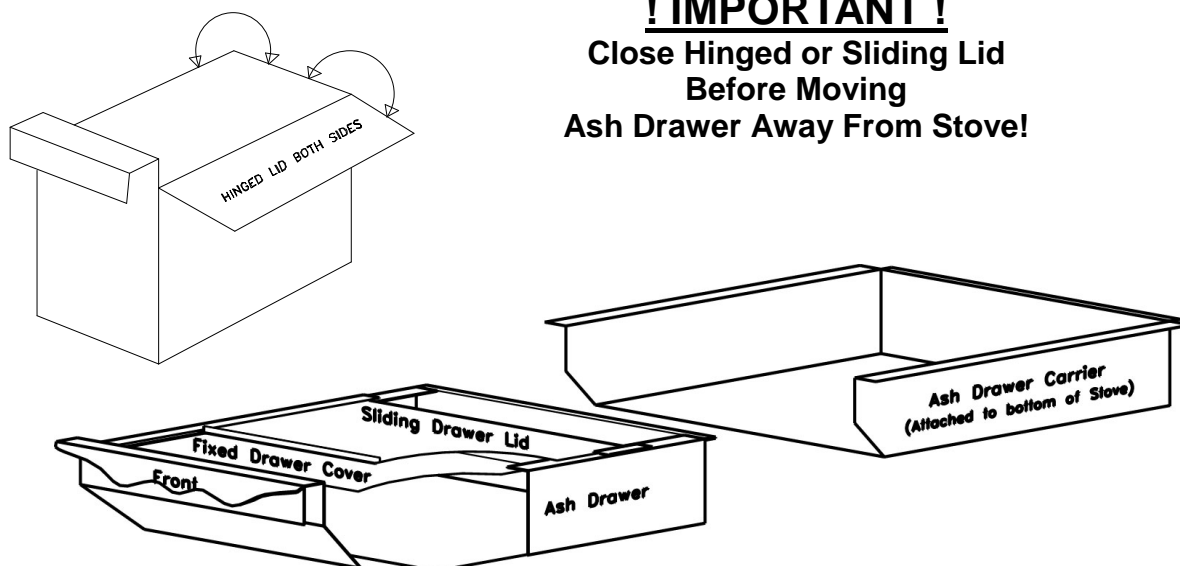
The ashes should be removed any time they come within one inch of the door's lower sill. A thick bed of ashes will significantly limit the amount of wood you can get in the firebox. Wood burns best in a bed of ashes 1/2 inch to one inch thick. It is not necessary or advisable to completely remove all of the ashes when cleaning this wood stove.

## **ASH PAN REMOVAL (OPTIONAL ON LEG MODEL, STANDARD ON ULTRA MODEL)**

If you have ordered and installed the optional ash pan for your leg model Princess Stove or have an ULTRA model stove with a standard ash pan; follow these instructions for ash removal.

**WARNING: REMOVE ASHES ONLY WHEN THEY ARE COOL. NEVER STORE HOT ASHES IN A GARAGE OR BASEMENT. HOT ASHES WILL GENERATE CARBON MONOXIDE AND / OR FLAMABLE GASES. THESE GASES MAY CAUSE SUFFOCATION BE SURE YOU OBSERVE THE SAFETY INSTUCTIONS REGARDING "DISPOSAL OF ASHES" DESCRIBED ABOVE.**

1. After the ash bed has cooled down, remove the ash plug located at the bottom centre of the firebox by slipping a poker or similar tool through the small handle loop on the top of the plug
2. Scrape the ashes down through the open ash dump hole and into the ash pan fitted into the stove pedestal. Do not be concerned about "cleaning" the fire box completely as the next fire will burn better on a small bed of ash (up to 1/2" deep).
3. When the necessary ashes have been dumped down the ash dump into the ash pan clean out the area around the dump to ensure that the plug fits properly back into the ash dump.
4. REPLACE THE ASH DUMP PLUG CAREFULLY TO ENSURE PROPER SEATING; NEVER OPERATE THE STOVE WITH THE PLUG REMOVED. TO OPERATE THE STOVE WITH THE PLUG REMOVED OR NOT PROPERLY IN PLACE IS DANGEROUS.
5. After you have replaced the ash dump plug spread the remaining ashes across the firebox and cover the ash dump plug with a layer of ashes.
6. ENSURE ASH PAN HAS COOLED DOWN AND IS SAFE TO HANDLE.  
Remove the ash drawer from the stove and slide or flip the hinged drawer lid closed to cover the open ash drawer. (See below,) CAUTION: ENSURE THE PAN HAS COOLED DOWN BEFORE REMOVAL.
7. Dispose of the ashes in a safe manner as described above: "DISPOSAL OF ASHES".
8. Before you replace the ash drawer back into the ash drawer carrier, ensure the carrier is cleaned to allow proper seating of the ash drawer. Replace the ash drawer into it's carrier, ensuring that the ash drawer lid is OPEN. It is important that the ash drawer be fully inserted into the ash drawer carrier.



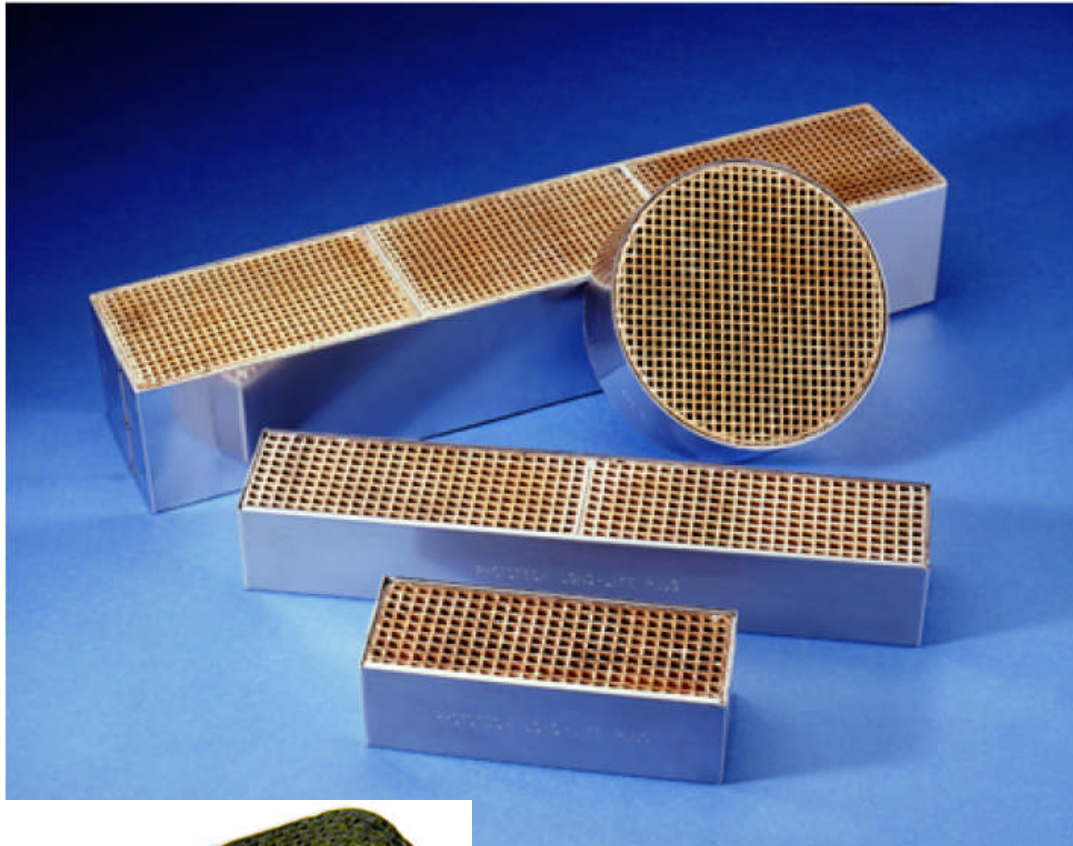
**! IMPORTANT !**  
**Close Hinged or Sliding Lid**  
**Before Moving**  
**Ash Drawer Away From Stove!**

# Süd Chemie Prototech

## Major Cleaning Procedures for

## Süd Chemie Prototech Catalytic Combustors

### Ceramic



< **Stainless steel**  
(same cleaning procedure)

## Major Cleaning Procedure for Süd-Chemie Prototech's Catalytic Combustors

---

The catalytic activity and effectiveness of a two to three year old Süd-Chemie Prototech Catalytic Combustor can be improved by following this "MAJOR CLEANING PROCEDURE". For normal maintenance, refer to your stove manufacturer's operation manual. Major cleaning should not be required more than once a year for heavy-use stoves and every two years for light-use stoves. This procedure should be followed only if the owner feels comfortable with performing this procedure. If not, a trained chimney sweep should be contacted.

Before attempting this cleaning procedure, familiarize yourself with your stove manufacturer's operation manual. Improper removal, handling or reinstallation of the catalytic combustor can damage it or your stove.

This cleaning procedure is for the catalytic combustor only, and it does not reduce or eliminate the need for regular chimney inspection and cleaning.

### Important Tips for Maximum Combustor Effectiveness:

1. Burn natural wood only. Do not burn trash, garbage, artificial or paper logs, gift wrappings, coal, lighter fluids, chemical starters, treated or painted wood, driftwood or chemical cleaners. These may contain chemicals that could deactivate the catalyst.
2. Catalytic combustor temperatures above 1800°F. (1000°C.) will shorten the life of a combustor. Combustor temperatures between 1400°F. and 1600°F. (760°C - 870°C.) are common, but operating temperatures between 700°F. and 1400°F. (371°C. - 760°C.) are recommended.
3. Full catalytic operation occurs at catalytic combustor temperatures above 700°F. (371°C.). Combustor glowing only occurs at temperatures above 1000°F. (538°C.). With aged combustors, there will be less glowing, but as long as the combustor reaches light-off temperature of 500-700°F. (260 - 371°C.) catalytic operation is very effective. **THE COMBUSTOR DOES NOT HAVE TO BE GLOWING TO BE OPERATING EFFICIENTLY.**
4. To prevent damage to your combustor, **do not**
  - drop the combustor
  - run water through the combustor
  - remove the metal band from the combustor
  - scrape the inside walls of the combustor
  - use compressed air to clean the combustor

### Major Cleaning Procedure

- Inspection
  - Necessary Equipment
  - Cleaning Steps
- 

#### ■ Inspection — Prior to Major Cleaning:

**CAUTION: DO NOT REMOVE THE COMBUSTOR WHILE IT OR ANY PORTION OF THE STOVE IS HOT.**

Carefully remove the combustor from the stove (see your Use & Care Manual). *Do not remove the stainless steel band or manufacturer's combustor holder from around the outside of the combustor.* It is very important that the unit is handled CAREFULLY. The combustor is a brittle ceramic and could break if it is handled roughly or dropped. Replace the combustor with a new part if it is damaged or worn out. Consult your Use & Care Manual or Süd-Chemie Prototech's Trouble Shooting Guide.

For the major cleaning to be effective, the combustor must not be coated with creosote, but should be light gray or beige in color. If the combustor is coated with creosote (dark black or dark brown), operate the stove with the combustor in place at a higher than your normal burn rate to burn-off the accumulated soot and creosote (see Süd-Chemie Prototech's Troubleshooting Guide). **USE CAUTION** — do not overheat the stove or chimney. Allow the stove and ashbed to cool completely before proceeding. Re-inspect the combustor. If the creosote build-up remains, repeat the burn-off procedure.

#### ■ Necessary Equipment:

- Combustor removal instructions from the Use & Care Manual for your stove.
- Distilled water — 2 to 3 gallons, enough to completely cover the combustor by at least ½", three separate times. Do not use tap water — it may contain minerals that will reduce the effectiveness of the cleaning.
- White vinegar — 2 to 3 quarts, enough to make a 50/50 solution with the distilled water to cover the combustor once.
- A pot — large enough to preheat the cleaning solution and the rinse water.
- An old pot or roasting pan — large enough for the combustor to be covered with at least ½" of cleaning solution. The top surface of the combustor must be covered with cleaning solution at all times. Do not reuse the pot for cooking purposes.
- Plastic-coated wire (16 gauge multi-strand works well) — for use as a grab handle. Do not scrape the inside walls of the combustor.
- Tools and materials required to remove and reinstall the combustor.
- Vacuum cleaner (one used in the home)



## ■ Cleaning Steps

### STEP 1

GENTLY REMOVE ANY LOOSE ASH FROM THE COMBUSTOR.

A home vacuum cleaner is effective, using either suction or exhaust. USE CAUTION – high air velocities can strip catalyst off the ceramic. (Never use a high pressure air hose!!) Any cells that are still plugged should be gently cleared using a cotton swab or pipe cleaner. Never scrub or abrade any part of the catalytic combustor, since this may remove the catalyst or damage the cells.

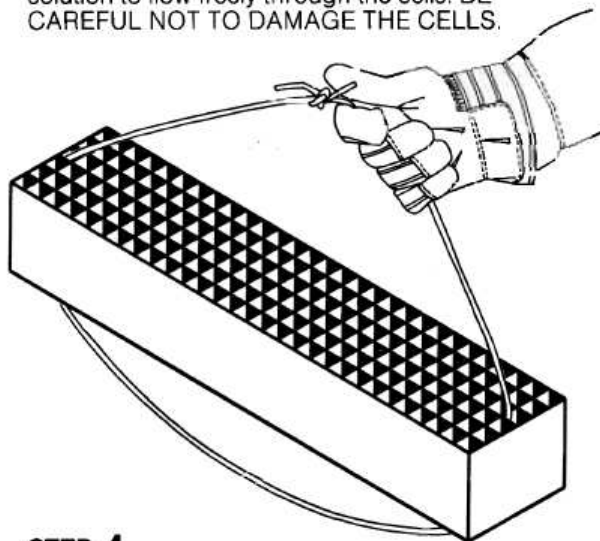
### STEP 2

PREPARE THE CLEANING SOLUTION.

Make a 50/50 mixture of vinegar and distilled water in the large pot. Heat the mixture to a boil.

### STEP 3

THREAD THE WIRE THROUGH THE COMBUSTOR TO MAKE A GRAB-HANDLE FOR LIFTING THE COMBUSTOR IN AND OUT OF THE HOT CLEANING SOLUTION. The wire will elevate the combustor off the bottom of the large pot, allowing the cleaning solution to flow freely through the cells. BE CAREFUL NOT TO DAMAGE THE CELLS.



### STEP 4

GENTLY PLACE THE COMBUSTOR INTO THE CLEANING SOLUTION.

The cleaning solution will evaporate slightly. Keep the combustor covered with at least  $\frac{1}{2}$ " of solution. Reduce the heat to just below boiling. It is not necessary to boil the cleaning solution once the combustor has been placed into the pot. Allow the combustor to remain in the hot cleaning solution for thirty (30) minutes.

NOTE: While the combustor is in the cleaning solution, heat to a boil enough distilled water for the two rinses (STEP 6 & STEP 7).

### STEP 5

After THIRTY MINUTES, remove the combustor from the cleaning solution.

Place it on a towel. Discard the used cleaning solution and rinse out the pot.

### STEP 6

Fill the pot with the boiling rinse water and gently place the combustor in the rinse water.

Allow the combustor to remain in the rinse water for 15 minutes. Keep the rinse water at just below boiling.

Meanwhile, preheat enough water for the second rinse cycle.

### STEP 7

AFTER 15 MINUTES, remove the combustor from the rinse water and gently shake out the excess water.

Repeat STEP 6.

It is unlikely that you will notice a visible difference in the combustor after this cleaning procedure.

### STEP 8

Reinstall the combustor.

After the cleaning procedure, follow the manufacturer's instructions for replacing the combustor and reassembling the stove.

Don't operate the stove for at least 24 hours. This will allow the combustor to dry and prevent steam from causing damage to the combustor. If the stove must be returned to operation immediately the combustor can be dried in an oven. Place the combustor in an oven at 300°F for 60 minutes. Turn off the oven and let it cool to room temperature.

This procedure has been found to be effective for non-damaged and non-worn out catalytic combustors. It will not revitalize a catalytic combustor if the catalyst has been worn out or damaged by use with improper combustibles or otherwise. Check the performance of your catalytic combustor regularly after cleaning. Reduced effectiveness as a result of age or damage may result in an increased rate of creosote accumulation in your chimney.