

SUBMITTAL DATA: MSY-GE18NA-8 & MUY-GE18NA-1

18,000 BTU/H WALL-MOUNTED AIR-CONDITIONING SYSTEMS

Job Name:	Location:	Date:
Purchaser:	Engineer:	
Submitted to:	For <input type="checkbox"/> Reference <input type="checkbox"/> Approval <input type="checkbox"/> Construction	
System Designation:	Schedule No.:	



Indoor Unit: MSY-GE18NA-8

 Wireless Remote
Controller

Outdoor Unit: MUY-GE18NA-1

GENERAL FEATURES

- Wall-mounted indoor unit
- Standard Hybrid Catechin Prefilter is included with indoor unit
- Quiet operation
- Auto fan speed control: Quiet, Low, Medium, High, and Super High
- Hand-held Wireless Remote Controller
- Indoor unit powered from outdoor unit using A-Control
- Auto restart following a power outage
- Anti-allergy Enzyme Filter
- Limited warranty: five years parts and seven years compressor

ACCESSORIES

Outdoor Unit

- Drain Socket Assembly (MAC-811DS)

Indoor Unit

- Condensate Pump (230V; SI3100-230)

Controller Options

- Wireless Wall-mounted Remote Controller Kit (MHK1)*
- Portable Central Controller (MCCH1)*
- Outdoor Air Sensor (MOS1)*
- Wired Wall-mounted Controller (PAR-31MAA requires MAC-333IF)*
- Simple MA Remote Controller (PAC-YT53CRAU requires MAC-333IF)*

*See Submittal for information on each option.

- System Control Interface (MAC-333IF)
- Remote Temperature Sensor (M21-JKO-307)
- Lockdown Bracket for Hand-held Controller (RCMKP1CB)



DIMENSIONS: MSY-GE18NA-8 & MUY-GE18NA-1

MSY-GE18NA-8

Unit: inch

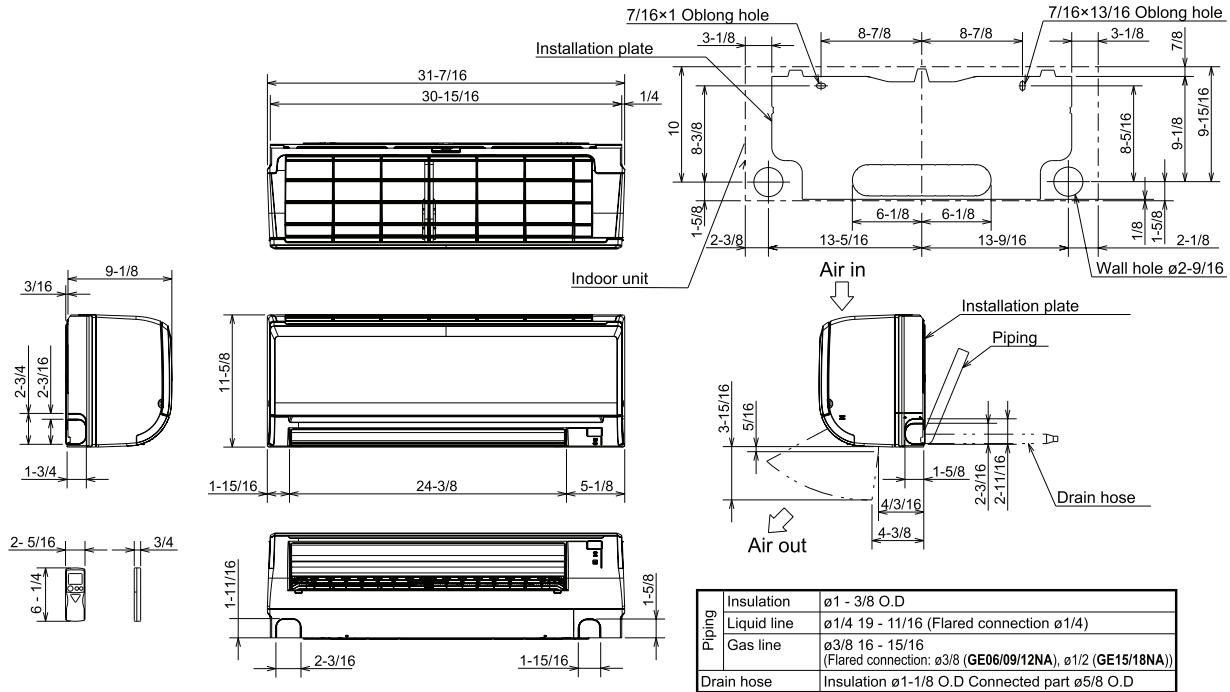

MUY-GE18NA-1

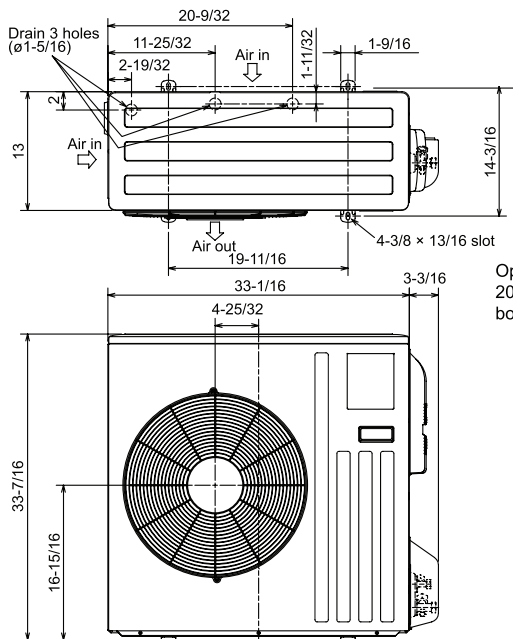

REQUIRED SPACE

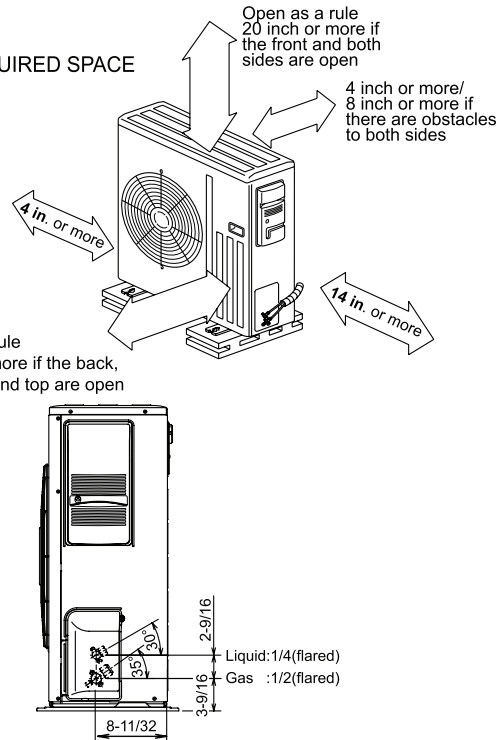

Intertek



1340 Satellite Boulevard
Suwanee, GA 30024
Tele: 678-376-2900 • Fax: 800-889-9904
Toll Free: 800-433-4822
www.mehvac.com