



## Operation Manual (v1.0)

Software version: 1.19

**MAGIC PLAY SP Z O.O.**

CHOCIMSKA 6, 62800 KALISZ, POLAND

Phone/Fax: +48 62 753 21 88. e-mail: [service@magicplay.pl](mailto:service@magicplay.pl)

website: [www.magicplay.eu](http://www.magicplay.eu)

Serial number: \_\_\_\_\_

Distributor: \_\_\_\_\_

Date: \_\_\_\_\_



## TABLE OF CONTENTS

1. PACKAGE CONTENTS.....	2
2. SPECIFICATIONS .....	4
3. SETUP & INSTALLATION .....	5
3.1 DEVICE AND IMPORTANT ELEMENTS .....	5
3.2 GAME ASSEMBLY .....	6
3.3 PLAY ZONE.....	10
3.4 CONNECTING POWER .....	10
4. GAMEPLAY .....	11
5. GAME OPTIONS.....	13
5.1 MENU ACCESS AND NAVIGATION.....	13
5.2 SERVICE MENU .....	14
5.3 RECOMMENDED SETTINGS .....	16
6. ELECTRICAL DIAGRAM .....	17
7. MAINTENANCE, INSPECTION .....	18
7.1 SAFETY CHECK .....	18
7.2 TROUBLESHOOTING .....	18
8. TERMS OF WARRANTY .....	21

Thank You for purchasing NINJA CHALLENGE. We hope you enjoy the product. The manual contains valuable information about how to operate and maintain your game machine properly and safely. It is intended for the owner and/or personnel in charge of product operation. Carefully read and understand the instructions.

If you need any help during instalation and setup please utilize this manual and troubleshooting guide. If the product fails to function properly, non-technical personnel should under no circumstance attempt to service the machine. Contact your distributor or manufacturer for help.

## READ BEFORE USE

### INSPECT IMMEDIATELY AFTER TRANSPORTING THE PRODUCT

After receiving the shipment, inspect the product thoroughly to ensure that it has been shipped with care. Before turning the power on, please check the following:

- Check the cabinet for damage or shifting that may have occurred during shipping. Are there any dented portions or defects (cuts, etc.) on the external surfaces of the cabinet?
- Are all the legs and adjusters/levelers/feet intact?
- Do the power supply voltage and frequency requirements meet with those of the location (115V/230V)?
- Are all wires linked correctly and securely connected to each other? If coupled in an incorrect manner, the connection will not be made accurately and it could cause not only irreparable damage to the machine, but also is a potential fire hazard. **DO NOT INSERT CONNECTORS FORCIBLY.**
- Check that the all the cables, including power cables, are undamaged. Do power cables or other wires have any splices, cuts, or dents?
- Have you been provided with all of the associated accessories?
- Can all doors/lids be opened with the accessory keys? Can doors/lids be firmly closed? Does the coin box key open the coin box(es)?

### 1. PACKAGE CONTENTS

Open the package and make sure all the items are included:

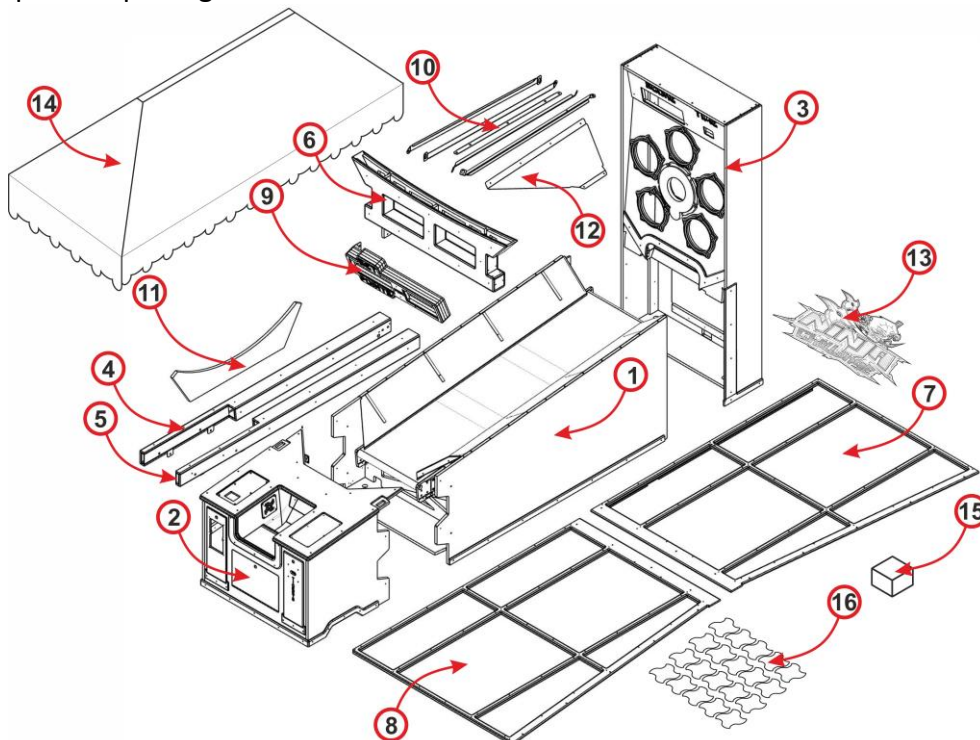

1. Middle part
2. Front part
3. Back part
4. Left post
5. Right post
6. Gate top
7. Left side wall
8. Right side wall
9. Bonus display
10. Roof frame assembly (5 pcs. set)
11. Roof top
12. Top cover
13. Top marquee
14. Roof cover
15. Set of screws and assembly elements
16. Stars 20 pcs.

If any items are found missing, please contact your sales representative for help immediately.

**NOTE: Part models are subject to change without notice.**



## IMPORTANT SAFETY INSTRUCTIONS

To ensure the safe usage of this product, carefully read and understand these instructions before operating your game. Save these instructions for future reference.

Use this product only as described in this manual. Other uses not recommended may cause fire, electric shock or personal injury. Unplug the game from the outlet when not in use, when moving from one location to another, and before cleaning/servicing.

Explanations which require special attention are indicated by signs of warning. Depending on the potential hazardous degree, the terms: **NOTE**, **NOTICE**, and **WARNING** are used.

**NOTE:** A NOTE indicates useful hints or information about product usage.

**NOTICE:** A NOTICE indicates potential damage to product and how to avoid the problem.

**WARNING:** A WARNING indicates a potential for product damage or serious personal injury.

It is important to understand the meaning of the following **HAZARD SIGNS** before continuing:



### High Voltage and Shock Hazard:

High voltage can cause electric shock.  
Turn off/unplug power before servicing.



### High Temperature Hazard:

This part may cause scalding.  
Do not touch. Surface may be hot.



### Do Not Touch Hazard:

This may be hot or can cause electric shock.  
Do not touch.

Use the following safety guidelines to help ensure your own personal safety and to help protect your equipment and surrounding environment from potential damage.

## THIS PRODUCT IS AN INDOOR MACHINE ONLY! DO NOT INSTALL OUTDOOR!



Avoid installing in the following places to prevent fire, electric shock, injury and/ or machine malfunctioning:

- Places subject to rain/ moisture, or places subject to high humidity.
- Places subject to direct sunlight, or places subject to extremely hot or cold temperatures to ensure that it is used within the specified operating range.
- Places where inflammable gas may be present or in the vicinity of highly inflammable/ volatile chemicals or items that can easily catch fire
- On unstable or sloped surfaces. The machine may topple or cause unforeseen accidents.
- Vicinity of fire exist, fire extinguishers.

## WARNING!

Non-technical personnel who do not have technical knowledge and experience should refrain from performing such work that this manual requires or perform tasks which are not explained in this manual. Failing to comply can cause severe accidents such as electric shock or other serious injuries.

**WARNING: To reduce the risk of fire, electric shock or personal injury, unplug or disconnect the machine from the power supply before servicing.**

## 2. SPECIFICATIONS

Rated power supply:	110 - 240V <b>(manual 115/230V voltage selection)</b>
Dimensions:	284 x 96 x 281cm, width of gate top part: 132cm
Weight:	227KG

**NOTICE: After turning off the game, please wait at least 1 minute before restarting again.**

Inspect Immediately after Transporting the Product After receiving the shipment, inspect the product thoroughly to ensure that it has been shipped with care. Before turning the power on, please check the following:

- Check the cabinet for damage or shifting that may have occurred during shipping. Are there any dented portions or defects (cuts, etc.) on the external surfaces of the cabinet?
- Are all the legs and adjusters/levelers/feet intact?
- Do the power supply voltage and frequency requirements meet with those of the location (110V/220V)? Are all wires linked correctly and securely connected to each other? If coupled in an incorrect manner, the connection will not be made accurately and it could cause not only irreparable damage to the machine, but also is a potential fire hazard. **DO NOT INSERT CONNECTORS FORCIBLY.**
- Check that all the cables, including power cables, are undamaged. Do power cables or other wires have any splices, cuts, or dents?

- Have you been provided with all of the associated accessories?
- Can all doors/lids be opened with the accessory keys? Can doors/lids be firmly closed? Does the coin box key open the coin box(es)?

### 3. SETUP & INSTALLATION

- Refer to IMPORTANT SAFETY INSTRUCTIONS for prohibited install locations
- Place the unit on dry, leveled surface
- Ventilation openings in the back of the unit must not be obstructed by objects or by wall.

#### 3.1 DEVICE AND IMPORTANT ELEMENTS

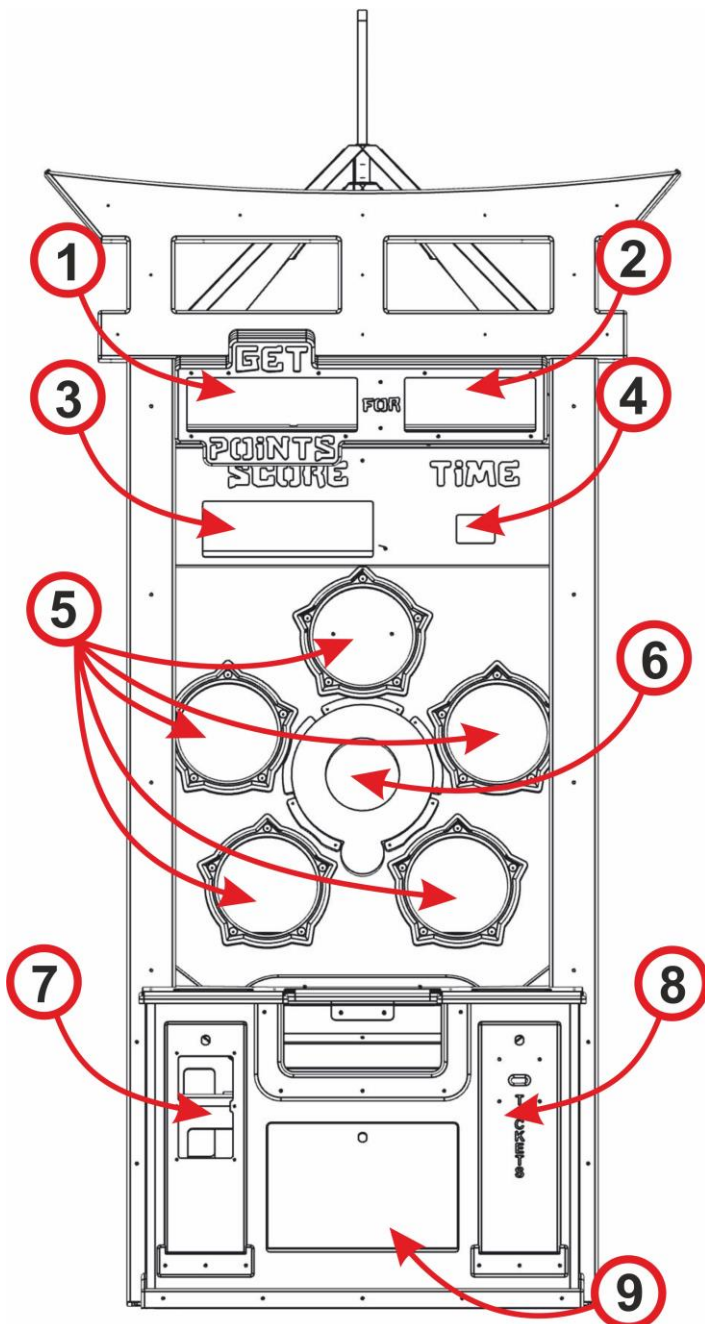

1. Points for tickets bonus display
2. Tickets bonus value display
3. Score display
4. Time display
5. Regular (outer) holes
6. Special (middle) hole with mechanism
7. Coin/bill acceptor, cash-box door
8. Tickets output, ticket container door
9. Service doors with PCB access

### 3.2 GAME ASSEMBLY

## IMPORTANT!

**At least two persons are needed to assemble the device. Installation by one person may not be possible due to the mass of the machine parts and the necessity of simultaneously supporting and screwing some of the components.**

Tools needed for assembly: ladder (using two ladders can facilitate and accelerate the assembly process).

Tools included in parts box - 3mm allen key, 4 mm allen key, 5mm allen key and two 13mm ring wrenches.



Elements needed to assemble the device (included in parts box).



M6x50 – set of 4



M6x30 – set of 4



M6x40 – set of 4



M5x15 – set of 2



M5x10 – set of 16



M8x35 – set of 2



M8x15 – set of 4



M5x20 – set of 18



6/13 – set of 2



Wing nut – set of 3



10/20 – set of 3



8/24 – set of 8



5/14 – set of 8

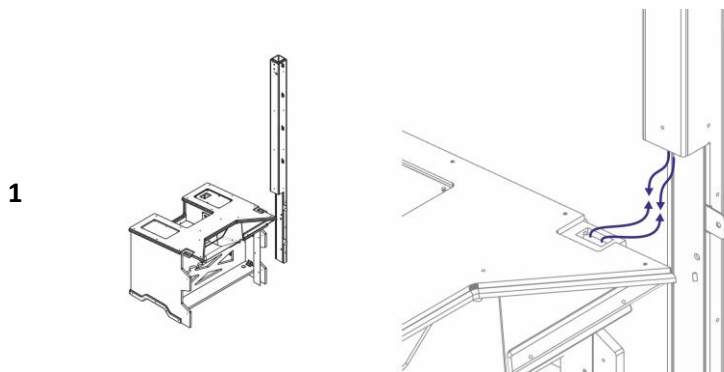

Connect the wires from the front of the machine to the wires of the left post. Place the excess cables and connectors in the hole in the front part. EU2-1962b-1 > EU2-1962b-1, EU2-2014 > EU2-2015

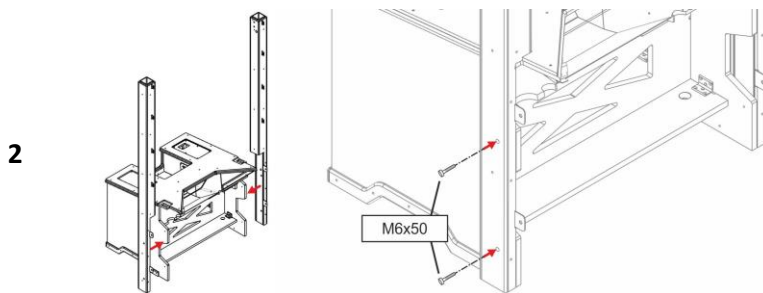

Move the pole to the side of the front part and screw in the indicated places using the screws M6x50. Perform the same operation on both sides of the device.

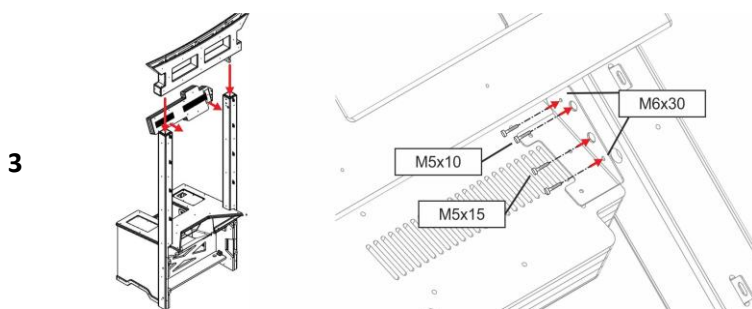

Attach the top of the gate by placing the tabs inside the posts and place the bonus display box between the posts. Screw the display box in the indicated places using the screws M5x15 and M5x10. Secure the fastening of the upper part of the gate by screwing in the marked places with screws M6x30. Perform the same operation on both sides of the device.

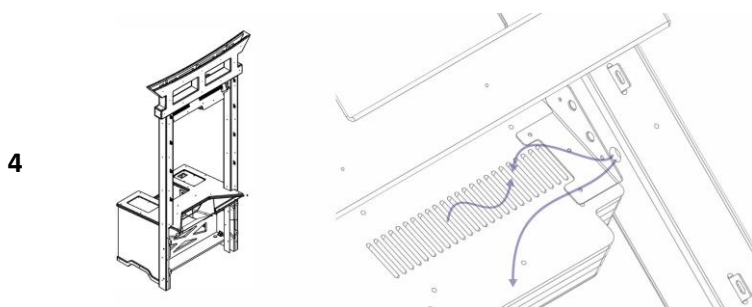

Connect the left pole wires with the bonus display box wires and with the foul line sensors.

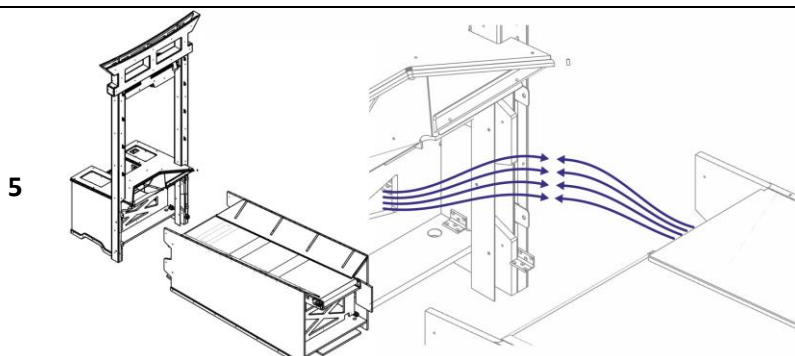

Bring the front part closer to the middle part. Connect a set of four wires from the front of the device with four wires from the middle part. AC POWER > AC POWER, EU2-1966-1 > EU2-1963-2, EU2-1966-1 > EU2-1966-2, EU2-1968b > EU2-1968b



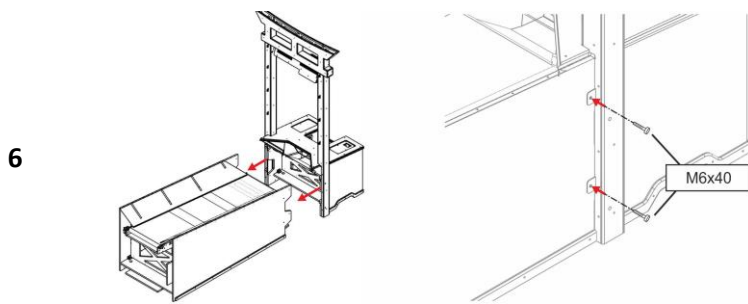

Move the front part to the middle part. Make sure that both parts are on the same level. Secure by screwing the M6x40 screws in the indicated places. Perform the same operation on both sides of the device.

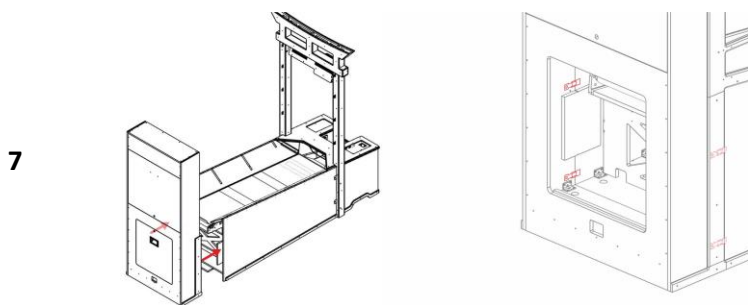

Move the rear part to the middle part. Make sure that both parts are on the same level. Remove the lower service door from the rear part of the device. Secure both elements using the four clamps shown in the picture.

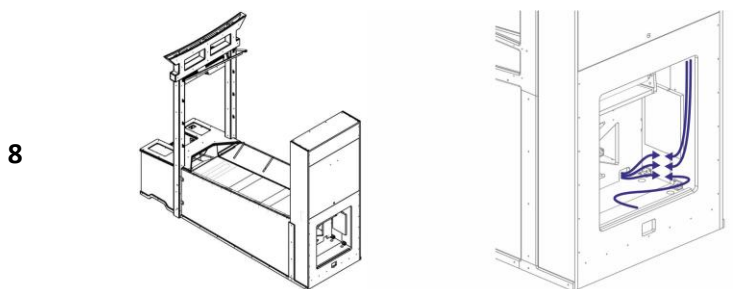

Connect a set of three wires from the middle part of the device with three wires from the rear part. AC POWER > AC POWER, EU2-1966-2 > EU2-1966-3, EU2-1968b > EU2-1968b

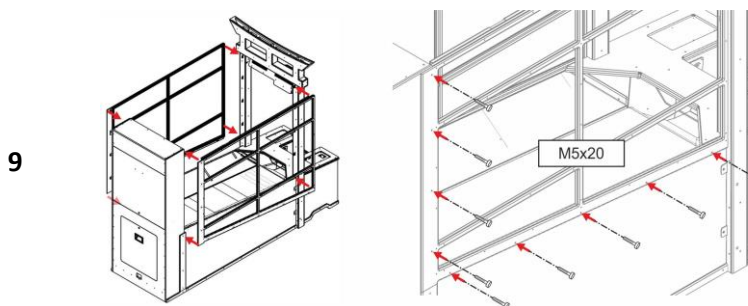

Screw the side walls to the middle and rear part in the indicated places, using the screws M5x20. Perform the same operation on both sides of the device.

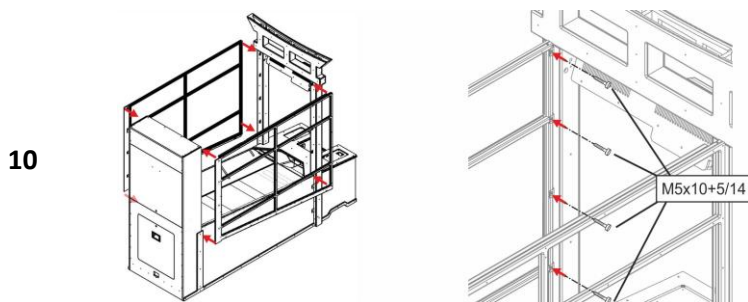

Screw the side walls to the posts in the indicated places, using the screws M5x10 and washers 5/14. Perform the same operation on both sides of the device.

11

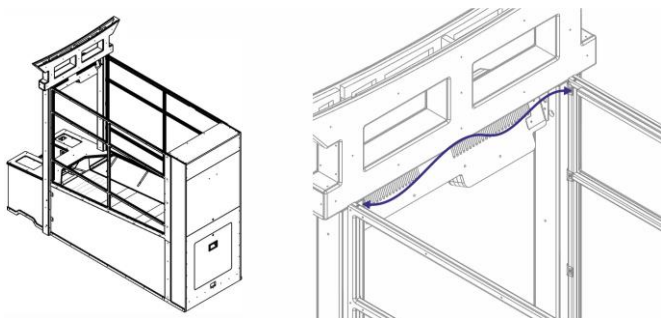

Connect the wires from the pole with the wires in the upper corners of the side walls.

12

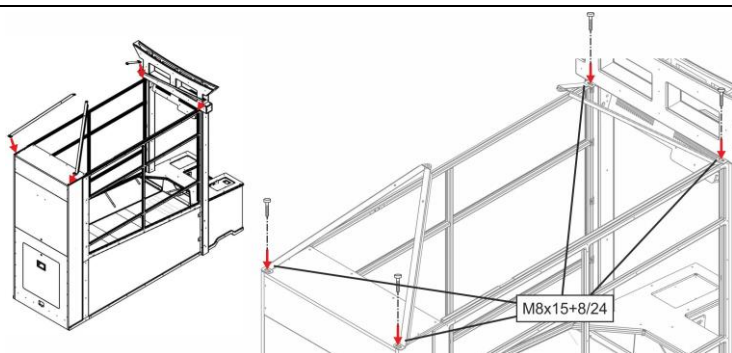

Fix the corner parts of the roof frame in the places indicated in the picture, using screws M8x15 and washers 8/24. Make it so that the ends of the left and right corners create a hole.

13

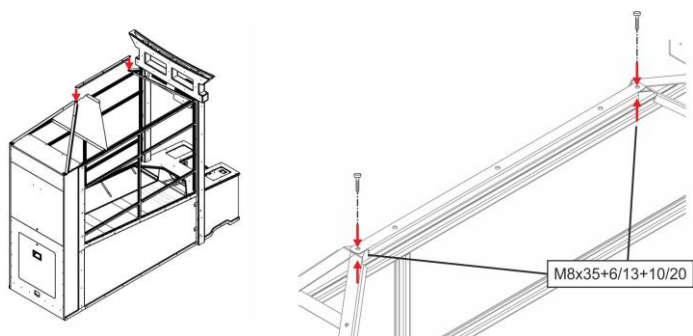

Place the center crossbar of the roof frame so that its openings fit into the holes in the corner parts. Tighten the holes using the M8x35 screws, 6/13 nuts and 10/20 washers on both sides.

14

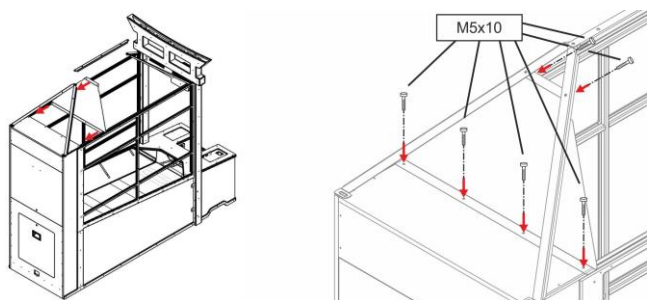

Fix the cover to the frame of the roof and the top of the back part of the device by screwing it in the indicated places, using the screws M5x10.

15

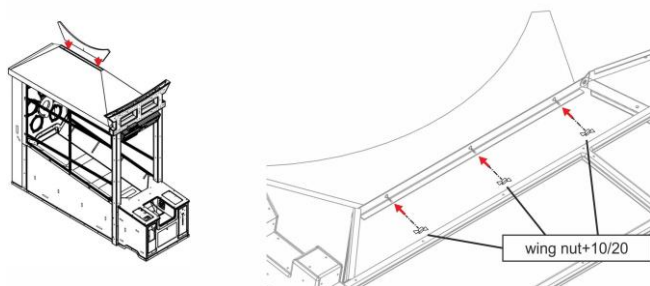

Put the roof on the frame so that the velcro strap is on the front of the device. Install the upper arch by inserting the threaded rods attached to it through the holes in the roof and frame. Secure assembly using wing nuts and 10/20 washers according to the picture.

### 3.3 PLAY ZONE

This machine requires space for playing and for maintenance as shown below.

Leave space around the game upon instalation:

Service area: 50cm

Play area: 100cm

### 3.4 CONNECTING POWER

## IMPORTANT!

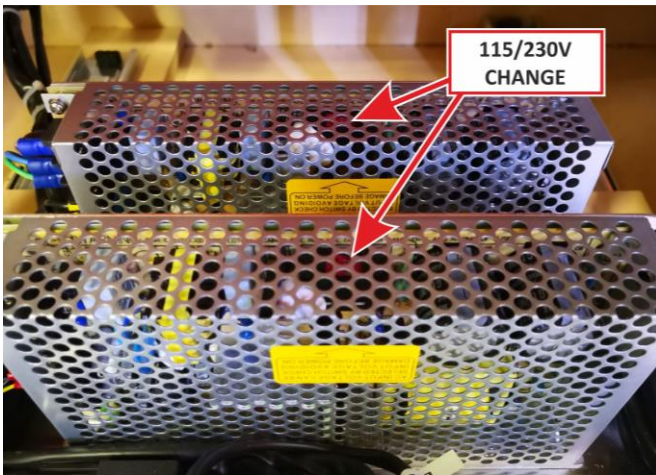

**CHANGE BETWEEN 115/230V INPUT VOLTAGE MUST BE SET MANUALLY. BEFORE CONNECTING THE DEVICE FOR THE FIRST TIME, MAKE SURE THAT THE VOLTAGE SET ON POWER SUPPLIES IS SAME AS THE VOLTAGE IN THE ELECTRICAL INSTALLATION OF YOUR LOCATION.**

- Do not plug the equipment power cables into an electrical outlet if the power cable is damaged.
- Avoid putting many loads on one electrical outlet as it could generate heat the fire resulting from overload.

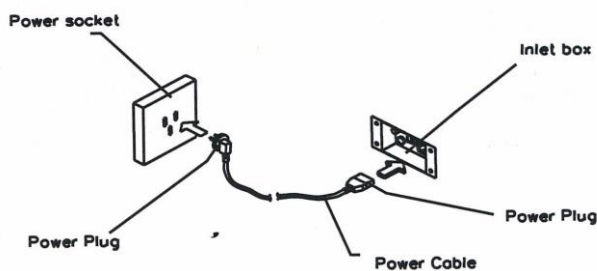

Connect the grounding conductor to the earth terminal (GND):

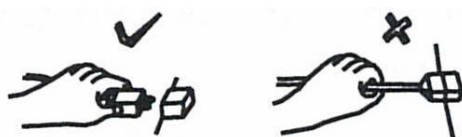

To disconnect the game, grip the plug and pul lit from the wall outlet. Never pull by the cord.



Ensure that nothing rests on the power cord and that it is not located where it can be stepped on or tripped over.



To prevent electric shock, do not touch the power plug when hand is wet.



## 4. GAMEPLAY

Player's task is to accurately throw stars to the holes to get the most points. There are two types of holes in the game: regular-external holes, and special-middle hole. The holes have their point value which is added to the player's score each time player hits inside the hole with the star. The point value of the holes can be set in the game settings.

To start the game, put a coin/banknote in the acceptor or move the card.

When the game begins, the transmission belt will start to work and move forward moving the stars towards the player. The score display will show 0000. The time display will show the time remaining until the end of the game - the time of the game can be set in the game settings.



Remember that the foul line can not be exceeded during the game. Exceeding this line will be detected by the system. A loud alarm signal will be activated, the transmission belt will be stopped, and the opportunity to earn points will be blocked. The game, however, will not stop and the countdown will continue. The penalty for exceeding the line lasts as much as the time of exceeding + 3 seconds. After this time, the game can be continued. This feature allows to prevent fraud attempts by entering the machine or trying to get closer to the holes in order to gain points more easily.

GET POINTS on screen	ULTIMATE TICKETS BONUS
4000	500
SCORE	TICKETS
0-200	10
200-500	15
500-1000	20
1000-1250	25
1250-1500	30
1500-1750	40
1750-2500	60
2500-...	80

Points for tickets list, allows you to check what number of points is needed to get the selected number of tickets. In this list there is also information about how many points are needed to get a ticket bonus.



A short game instruction is located on the left side of the panel. There is also information about the number of points for hitting the holes, and a credit display.



After starting the game, the outer holes are highlighted in blue and the five-part ring around the center hole is highlighted in red. The middle hole is closed.

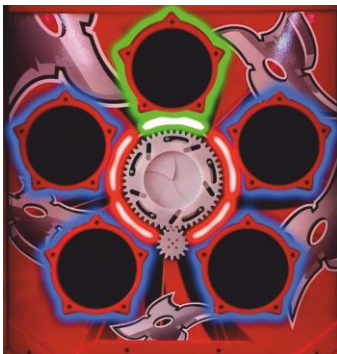

If the star is cast into one of the outer rings, the color of the lighting around the hole will change from blue to green. The part of the ring around the central hole will change the color of lighting from red to green. The number of points equal to the value of the outer circle will be added to the player's score. The number of points will be displayed on the score display.



If each of the outer holes is hit at least once, all the holes will change backlight from blue to green, and all parts of the ring around the center hole will change from red to green. This means that all conditions for opening the middle hole have been met.



The middle hole opens for a specified time (time can be set in the game settings). The point value for a hit in the center hole will be added to the point display each time the star goes to the hole. Note that when you open the central hole, the backlighting of the outer holes will change from green to blue one by one. The same with parts of the ring around the central hole. This is the countdown of the time to close the central hole.



When the backlight of all external openings turns blue and the ring around the central hole lights up red, the middle hole closes. To re-open the central hole, hit all outer holes again. The game lasts until the countdown of the game time is over. At the end of the game, the player can compare his score with the table in the game panel to check what amount of tickets should he receive for the points scored by the player.



## 5. GAME OPTIONS

### 5.1 MENU ACCESS AND NAVIGATION

To access menu press ENTER/SELECT button, located in service door, at the lower left front of the machine, next to the coin and ticket counters.

Use UP/+ and DOWN/- buttons to navigate in the menu. Use ENTER/SELECT to ENTER or SELECT the option value or selection



## IMPORTANT!

**REMEMBER THAT CHANGES IN THE SERVICE MENU CAN RELATE TO ELEMENTS SUCH AS THE COST OF THE GAME AND THE NUMBER OF WON TICKETS, AND WHICH MAY AFFECT THE EARNINGS OF THE DEVICE. MAKE SURE THAT THE CHANGES AND ENTERED VALUES ARE VALID.**



## 5.2 SERVICE MENU

MAIN MENU			
Game Version: 1.XX	Indicates software version		
DEVICE SETTINGS	MUSIC VOLUME	0-100	Set music volume
	SFX VOLUME	0-100	Set effects volume
	DEMO VOLUME	0-100	Set demo volume
	FILTR BARRIER	0.1-5 s	Set alarm barrier sensitivity
GAME SETTINGS	DEMO INTERVAL	0-60 minutes	Set demo frequency
	GAME TIME	10-999 seconds	Set game time
	SPECIAL TARGET TIME	1-99 seconds	Set special target open time
	SPECIAL BONUS TIME	0-10 seconds	Set additional bonus time for each hit
	NORMAL TARGET VALUE	0-100	Set points for each hit at normal target
	SPECIAL TARGET VALUE	0-500	Set point for each hit at special target
CREDIT SETTINGS	SERVICE GAME	ON / OFF	Play service game, no credits needed
	GAME PRICE	1-20	How many credits needed to play 1 game
	COIN PULSE VALUE   COUNTER	1-10	Value of PULSE coin acceptor & for counters
	COIN CH1 VALUE	1-50	Value of CH1 coin acceptor & for counters
	COIN CH2 VALUE	1-50	Value of CH2 coin acceptor & for counters
	COIN CH3 VALUE	1-50	Value of CH3 coin acceptor & for counters
	COIN CH4 VALUE	1-50	Value of CH4 coin acceptor & for counters
	BILL PULSE VALUE	1-200	Value of PULSE bill acceptor & for counters
TICKET SETTINGS	TICKET	ON / OFF	
	TICKETS DEVICE	- ENTROPY TD-963P - ENTROPY TD-963CR - YENOX YN-11 - HOPPER MKII - NO DISPENSER	default: ENTROPY TD-963CR
	TICKET VALUE	1, 2	Change won tickets value
	BONUS TARGET POINTS	0 - 9000	Minimum value for bonus win
	BONUS TICKET VALUE	0 – 999 tickets	Set ticket bonus value
	1. POINTS   TICKETS	0-9999 points 0-999 tickets	Set threshold point for tickets win
	2. POINTS   TICKETS	0-9999 points 0-999 tickets	Set threshold point for tickets win
	3. POINTS   TICKETS	0-9999 points 0-999 tickets	Set threshold point for tickets win
	4. POINTS   TICKETS	0-9999 points 0-999 tickets	Set threshold point for tickets win



	5. POINTS   TICKETS	0-9999 points 0-999 tickets	Set threshold point for tickets win	
	6. POINTS   TICKETS	0-9999 points 0-999 tickets	Set threshold point for tickets win	
	7. POINTS   TICKETS	0-9999 points 0-999 tickets	Set threshold point for tickets win	
	8. POINTS   TICKETS	0-9999 points 0-999 tickets	Set threshold point for tickets win	
COUNTERS	RESETABLE	CREDITS	Total coins	
		GAMES	Total games	
		TICKETS	Total tickets given	
	NON-RESETABLE	COINS	Total coins	
		GAMES	Total games	
		TICKETS	Total tickets given	
STATS	AVERAGE SCORE		Show average score	
	AVERAGE TICKETS WIN		Show average tickets win	
	SPECIAL TARGET COUNT		Show how special target hits	
	SPECIAL TARGET OPEN		Show how special target opens	
	BIG WIN COUNT		Show bonus wins count	
TESTS	INPUT DEVICES	BARRIER OPTO_1 OPTO_2 OPTO_3 OPTO_4 OPTO_5 OPTO_6	Check normal and special target optical sensors.	
		COIN ACCEPTOR	Check coin acceptor	
		BILL ACCEPTOR	Check bill acceptor	
		SAFETY BARRIER	Check safety(alarm) barrier	
	OUTPUT DEVICES	DISPLAY: - POINTS - BONUS POINTS - BIG BONUS - CREDITS - TIME - LINE LED TIME		Check displays
		MOTOR TEST		Check motor for special target
		LED SLOTS RGB		Check RGB LED illumination for TARGET slots
		TICKET DISPENSER		Check ticket dispenser
		CONVEYOR BELT		Check conveyor belt
8. FACTORY SETTINGS			Reset to factory settings	
9. SAVE & EXIT			Save changes and exit	





### 5.3 RECOMMENDED SETTINGS

~20 TICKETS/GAME   KIDS ~10 TICKETS/GAME			
GAME SETTINGS			
GAME TIME	45 sec.		
SPECIAL TARGET TIME	5 sec.		
SPECIAL BONUS TIME	1 sec.		
NORMAL TARGET VALUE	40		
BONUS TARGET VALUE	500		
TICKET SETTINGS		VALUE	TICKETS
TICKETS	ON		
TICKET VALUE	1		
BONUS TARGET POINTS	8000		
BONUS TICKET VALUE	500		
1. POINTS	0	5	
2. POINTS	400	10	
3. POINTS	1000	15	
4. POINTS	2000	20	
5. POINTS	2500	25	
6. POINTS	3000	35	
7. POINTS	4000	50	
8. POINTS	5000	70	

~45 TICKETS/GAME   KIDS ~30 TICKETS/GAME			
GAME SETTINGS			
GAME TIME	45 sec.		
SPECIAL TARGET TIME	7 sec.		
SPECIAL BONUS TIME	3 sec.		
NORMAL TARGET VALUE	50		
BONUS TARGET VALUE	500		
TICKET SETTINGS		VALUE	TICKETS
TICKETS	ON		
TICKET VALUE	1		
BONUS TARGET POINTS	8000		
BONUS TICKET VALUE	500		
1. POINTS	0	15	
2. POINTS	400	20	
3. POINTS	1000	25	
4. POINTS	2000	30	
5. POINTS	2500	40	
6. POINTS	3000	50	
7. POINTS	4000	70	
8. POINTS	5000	100	

~30 TICKETS/GAME   KIDS ~17 TICKETS/GAME			
GAME SETTINGS			
GAME TIME	45 sec.		
SPECIAL TARGET TIME	7 sec.		
SPECIAL BONUS TIME	2 sec.		
NORMAL TARGET VALUE	50		
BONUS TARGET VALUE	500		
TICKET SETTINGS		VALUE	TICKETS
TICKETS	ON		
TICKET VALUE	1		
BONUS TARGET POINTS	8000		
BONUS TICKET VALUE	500		
1. POINTS	0	10	
2. POINTS	400	15	
3. POINTS	1000	20	
4. POINTS	2000	25	
5. POINTS	2500	30	
6. POINTS	3000	40	
7. POINTS	4000	60	
8. POINTS	5000	80	

~60 TICKETS/GAME   KIDS ~45 TICKETS/GAME			
GAME SETTINGS			
GAME TIME	60 sec.		
SPECIAL TARGET TIME	10 sec.		
SPECIAL BONUS TIME	2 sec.		
NORMAL TARGET VALUE	50		
BONUS TARGET VALUE	500		
TICKET SETTINGS		VALUE	TICKETS
TICKETS	ON		
TICKET VALUE	1		
BONUS TARGET POINTS	8000		
BONUS TICKET VALUE	750		
1. POINTS	0	15	
2. POINTS	400	20	
3. POINTS	1000	25	
4. POINTS	2000	30	
5. POINTS	2500	40	
6. POINTS	3000	50	
7. POINTS	4000	75	
8. POINTS	5000	100	



## 6. ELECTRICAL DIAGRAM

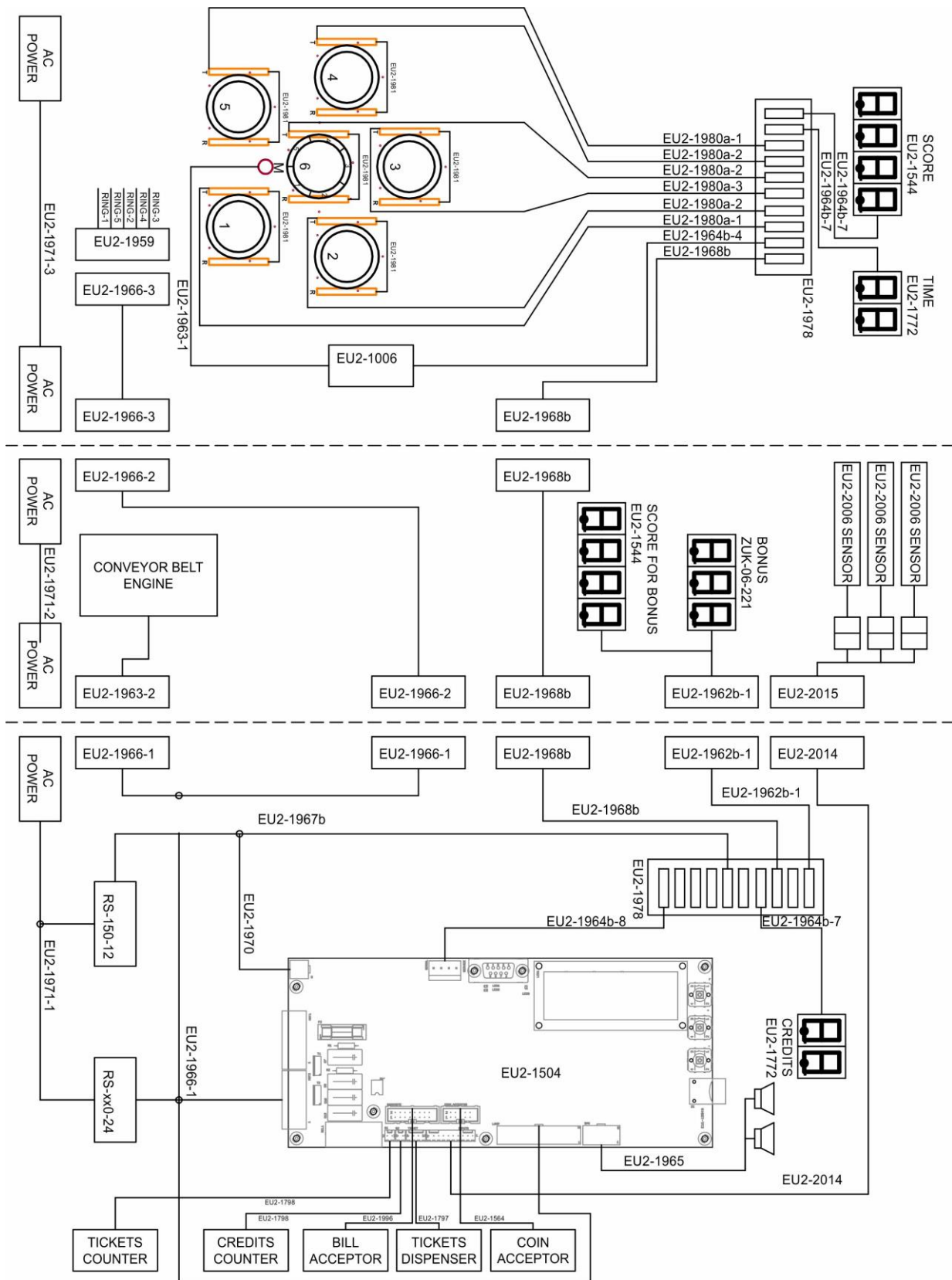

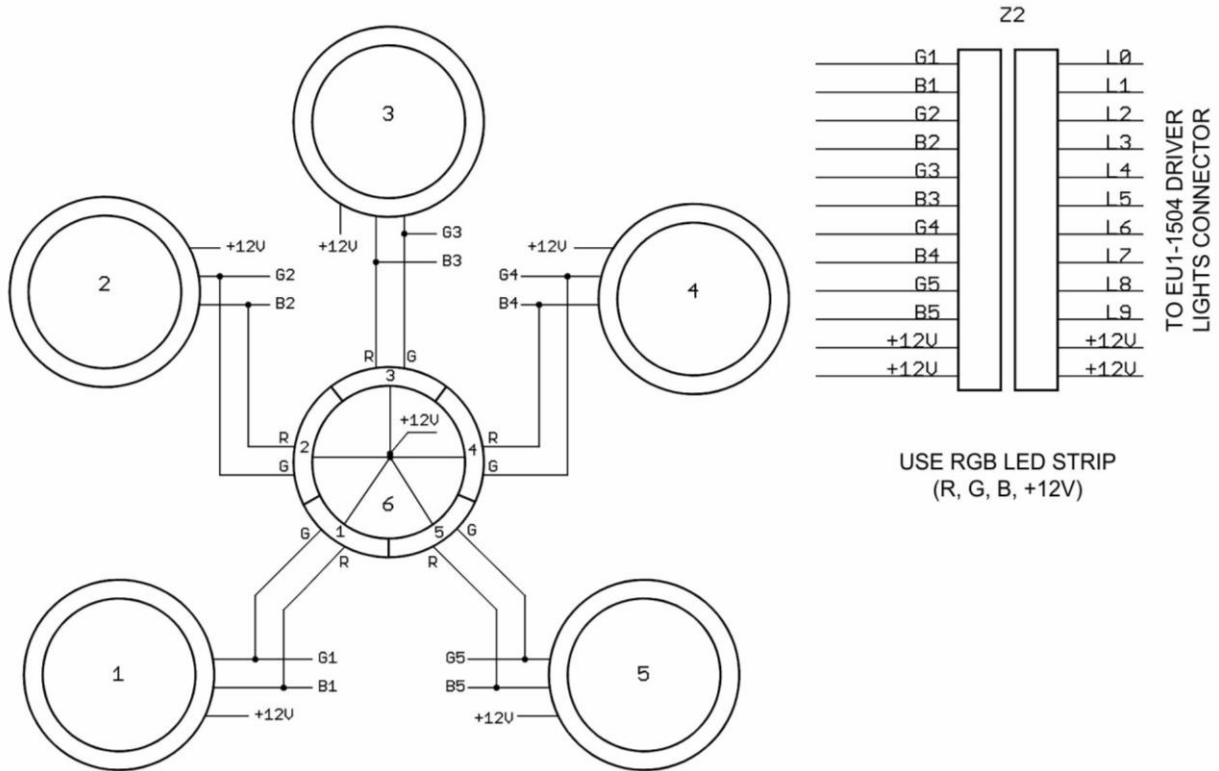

## 7. MAINTENANCE, INSPECTION

### 7.1 SAFETY CHECK

Check the points listed before operating the machine. These checks are necessary for safe machine operation:

1. Try to run the game before operation each day.
2. Conduct monthly routine checks of game components to ensure good working condition
3. Check the machine regularly for dust and clean when necessary.

Note : Parts and components require preventative maintenance to be kept running smoothly

### 7.2 TROUBLESHOOTING

#### Ticket dispensing is not working

1. Check Ticket settings in service menu and make sure that they are turned ON, and proper ticket dispenser is selected
2. Check ticket dispenser wiring and connections
3. Check ticket dispenser

#### Coin acceptor/bill acceptor is not working

1. Check Credit settings in service menu and make sure that everything is set properly
2. Check coin/bill acceptor wiring and connections
3. Check coin/bill acceptor



**No sound**

1. Check device settings in service menu
2. Check speakers wiring and connections
3. Check/replace microSD card with sounds

**Alarm is full time on**

1. Make sure that there is no objects on „FOUL LINE” sticker surface.
2. Check three optical sensors placed just behind POINTS FOR TICKETS BONUS display. Optical sensor photo:



- tip 1: diode 1 light ON: sensor detected barrier interruption  
tip 2: diode 1 light OFF: no barrier interruption

3. If nothing is physically braking barrier, but the #1 Light is ON then make regulation with #2 Screw: right to increase, left to decrease range of sensor
4. If regulation is not possible: replace faulty sensor

**Special target mechanism not working and it is always open/close**

1. Run test procedure from service menu
2. Check wiring and connections
3. Check possible collisions inside special target mechanism
4. Check motor/driver PCB

**Normal/special target hole is not detecting objects**

1. Run test procedure from service menu and break barrier by hand
2. Check wiring and connections
3. Working barrier module should blink with 2 green LED and 1 red LED
4. Swap sensor modules and check results

Tip: every sensor module have own adressation and it's not important where you connecting it. It will always have the same hole number in system.

**Normal/special target LED lighting is not working**

1. Run test procedure from service menu
2. Check wiring and connections
3. Check or replace LED lights module



**Conveyor belt is not working**

1. Run test procedure from service menu
2. Check wiring and connections
3. Check possible collisions
4. Check/replace conveyor belt motor

**Plugged in and nothing happened**

1. Check power wiring
2. Check power supplies placed behind front-central doors – green LED light means OK
3. Check power supplies voltage-input settings. You need to chose between 115/230V before connecting it to the electrical outlet for the first time. Manufacturer set it to default voltage for country of machine destination.
4. Check main board or replace



## 8. TERMS OF WARRANTY

Magic Play Sp. z o.o. warrants that the PIZZA EXPRESS game will be free from electronical and mechanical defects for a period of 12 months from the date of delivery.

Warranty covers:

- Display
- CPU board
- I/O board
- Power supplies
- LED driver
- LED lighting

Warranty terms do not cover parts not included above.

### Definition of defect:

It will be considered as defective if any connection between subcomponents on a particular board fails or any of them stops working itself. It does not include damages which occurred due to misuse, unauthorized connection or modifications.

**Should the product prove defective during the warranty period, Magic Play, at its option, shall:**

1. Repair the defective part by means of telephone support or depot service at no charge for parts of labor.
2. Replace the defective part with a comparable product which may be new or refurbished.

Provided that

1. Magic Play is informed of the defect immediately after it occurred. The faulty part should be dispatched to Magic Play or its authorized distributor as soon as possible.
2. Magic Play diagnoses the defects were not caused by improper use, neglect, unauthorized modifications, repair, setup or testing.
3. Only parts recommended and approved by Magic Play are covered by Magic Play Terms of Warranty.

**UNDER NO CIRCUMSTANCES SHALL MAGIC PLAY SP. Z O.O. BE HELD RESPONSIBLE FOR  
LOSES IN PROFIT, USAGE OR ACCIDENTAL SERIOUS DAMAGE TO THE MACHINE!**

**Magic Play sp. z o.o.**

**Adress:** Chocimska 6

62800 Kalisz, POLAND

**Phone:** +48 62 753 21 88

**Website:** [www.magicplay.eu](http://www.magicplay.eu)

Empty rounded rectangular box

Empty rounded rectangular box

Empty rounded rectangular box

Empty rounded rectangular box

Empty rounded rectangular box

Empty rounded rectangular box

Empty rounded rectangular box

Empty rounded rectangular box

Empty rounded rectangular box

Empty rounded rectangular box

Empty rounded rectangular box

Empty rounded rectangular box

Empty rounded rectangular box

Empty rounded rectangular box

Empty rounded rectangular box

Empty rounded rectangular box

Empty rounded rectangular box

Empty rounded rectangular box



Empty rounded rectangular box

Empty rounded rectangular box

Empty rounded rectangular box

Empty rounded rectangular box

Empty rounded rectangular box

Empty rounded rectangular box

Empty rounded rectangular box

Empty rounded rectangular box

Empty rounded rectangular box

Empty rounded rectangular box

Empty rounded rectangular box

Empty rounded rectangular box

Empty rounded rectangular box

Empty rounded rectangular box

Empty rounded rectangular box

Empty rounded rectangular box

Empty rounded rectangular box

Empty rounded rectangular box







Two empty rounded rectangular boxes stacked vertically, intended for writing or drawing.



Two empty rounded rectangular boxes stacked vertically, intended for writing or drawing.

**8000**

**500**

**0-400**

**5**

**400-1000**

**10**

**1000-2000**

**15**

**2000-2500**

**20**

**2500-3000**

**25**

**3000-4000**

**35**

**4000-5000**

**50**

**5000-...**

**70**



~20 TICKETS/GAME | KIDS ~10 TICKETS/GAME



**40**

**500**

**8000**

**500**

**0-400**

**10**

**400-1000**

**15**

**1000-2000**

**20**

**2000-2500**

**25**

**2500-3000**

**30**

**3000-4000**

**40**

**4000-5000**

**60**

**5000-...**

**80**



~30 TICKETS/GAME | KIDS ~17 TICKETS/GAME



**50**

**500**

**8000**

**500**

**0-400**

**15**

**400-1000**

**20**

**1000-2000**

**25**

**2000-2500**

**30**

**2500-3000**

**40**

**3000-4000**

**50**

**4000-5000**

**70**

**5000-...**

**100**



~45 TICKETS/GAME | KIDS ~30 TICKETS/GAME



**50**

**500**



**8000**

**500**

**0-400**

**15**

**400-1000**

**20**

**1000-2000**

**25**

**2000-2500**

**30**

**2500-3000**

**40**

**3000-4000**

**50**

**4000-5000**

**75**

**5000-...**

**100**



~60 TICKETS/GAME | KIDS ~45 TICKETS/GAME



**50**

**500**