

S86A

Integrated Multi-Room A/V Controller



ELAN[®]
HOME SYSTEMS

Preface

Purpose of This Manual

This manual provides step-by-step installation instructions and connection examples, along with basic user information for installation and ongoing use of the S86A Multi-Room Integrated Controller. This manual is written for the installer of this equipment.

Organization

The following information is contained in this manual:

Safety Information	Provides a comprehensive list of safety practices and procedures allowing for the safe installation and operation of ELAN Home Systems' S86A Integrated Multi-Room A/V Controller.
S86A Introduction	Provides an introduction to ELAN Home Systems' S86A Integrated Multi-Room A/V Controller, along with system features to include Front and Rear panel controls, indicators and connections, along with a short description of each.
S86A System Design Overview	Provides a system design application overview of the S86A Integrated Multi-Room A/V Controller for use in audio, video and automation applications.
S86A Connections	Provides a description of S86A Integrated Multi-Room A/V Controller system connections to included connections made with an ELAN System Precision Panel (SPP) and direct connections from the S86A to all other components.
Troubleshooting	Provides troubleshooting tables to help fix common discrepancies that may be associated with the S86A Integrated Multi-Room A/V Controller.
Specifications	Appendix A provides equipment specifications for the S86A Integrated Multi-Room A/V Controller.
Programming	Appendix B provides a basic overview of steps necessary to download programming information from VIA!@TOOLS or ELAN@TOOLS Setup software to the S86A Integrated Multi-Room A/V Controller.
RS-232 Protocol	Appendix C contains all information necessary to create RS-232 command structures when controlling the S86A Integrated Multi-Room A/V Controller with a third-party RS-232 control device.
Rack Mounting	Appendix D contains all information necessary to mount the S86A to the optional ELAN RMK3 Rack-Mount Kit.

Safety Information



RISK OF ELECTRIC SHOCK DO NOT OPEN!

CAUTION: TO REDUCE THE RISK OF ELECTRIC SHOCK, DO NOT REMOVE COVER (OR BACK). NO USER SERVICEABLE PARTS INSIDE. REFER SERVICING TO QUALIFIED SERVICE PERSONNEL.



The lightning flash with arrowhead symbol within an equilateral triangle is intended to alert the user to the presence of uninsulated "dangerous voltage" within the product's enclosure that may be of sufficient magnitude to constitute a risk of electric shock to persons.



The exclamation point within an equilateral triangle is intended to alert the user to the presence of important operating and maintenance (servicing) instruction in the literature accompanying the appliance.

WARNING: TO REDUCE THE RISK OF FIRE OR SHOCK,
DO NOT EXPOSE THIS APPLIANCE TO RAIN OR MOISTURE.

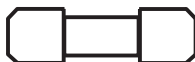

SOME DETACHABLE POWER CORD SOCKETS HAVE THIS FUSE SYMBOL WHICH INDICATES THERE IS A REPLACEABLE FUSE WITHIN THE SOCKET. FOR SAFETY PURPOSES REPLACE ONLY WITH SPECIFIED FUSE.

IMPORTANT SAFETY INFORMATION

Read Information—All the safety and operating information should be read before the appliance is operated.

Follow Information—All operating and use information should be followed.

Retain Information—The safety and operating information should be retained for future reference.

Heed Warnings—All warnings on the appliance and in the operating instructions should be heeded.

Wall Mounting—Mounting of this appliance should be done only by an authorized installer.

Ventilation—The appliances should be situated so that their location or position does not interfere with their proper ventilation. These appliances should never be placed near or over a radiator or heat register.

-These appliances should not be placed in a built-in installation such as a bookcase or cabinet that may impede the flow of air through the ventilation openings.

Non-Use Periods—Appliances that are left unattended and unused for long periods of time should be de-energized.

Grounding or Polarization—Do not defeat the safety purpose of the polarized or grounding-type plug. A polarized plug has two blades with one blade wider than the other blade. A grounding type plug has two blades and a third grounding prong. The polarized wide blade and the third prong are provided for your safety. If the provided plug does not fit your outlet, consult an electrician for replacement of the obsolete outlet.

Power Cord Protection—Protect the power cord from being walked on or pinched particularly at plugs, convenience receptacles and the point where they exit from the apparatus.

Water—Do not use the apparatus near water.



Cleaning—Unplug the apparatus from the power outlet before cleaning. Use only a dry cloth to clean the apparatus.

Power Lines—An outdoor antenna should be located away from power lines. When installing an outside antenna system, extreme care should be taken to avoid touching power lines or circuits, as contact with them may be fatal.

Object and Liquid Entry—Never insert objects of any kind through the openings of these appliances, as they may touch dangerous voltage points or short-out parts that could result in a fire or electric shock. Care should be taken so that objects do not fall and liquids are not spilled into the appliance through openings in the enclosure.

Servicing—Do not attempt to service these appliances yourself, as opening or removing covers may expose you to dangerous voltage or other hazards. Refer all servicing to qualified service personnel.

Damage Requiring Service—These appliances should be serviced by qualified service personnel when:

- A power supply connection or a plug has been damaged or
- If liquid has been spilled into the appliance or objects have fallen into the appliance or
- The appliance has been exposed to water or moisture or
- The appliance does not appear to operate normally or exhibits a marked change in performance or
- The appliance has been dropped or the enclosure damaged.

Replacement Parts—When replacement parts are required, be sure the service technician has used replacement parts specified by the manufacturer or that have the same characteristics as the original part. Unauthorized substitutions may result in fire, electric shock, or other hazards. The Master Control Unit battery should be replaced only after turning the power off and only by an authorized installer.

Safety Check—Upon completion of any service or repairs to this audio product, ask the service technician to perform safety checks to determine that the audio product is in proper operating condition.

Lightning Storms—Unplug this apparatus during lightning storms or when unused for long periods of time.

Attachments and Accessories—Use only attachments/accessories specified by the manufacturer.

Cart, Stand, Tripod, Bracket or Table—Use only with a cart, stand, tripod, bracket or table specified by the manufacturer, or sold with the apparatus. When a cart is used, use caution when moving the cart/apparatus combination to avoid injury from tip over.

Disconnect Device—Where the mains plug or an appliance coupler is used as the disconnect device, the disconnect device shall remain operable.

NOTE:

This equipment has been tested and found to comply with the limits for a Class B digital device, pursuant to part 15 of the FCC Rules. These limits are designed to provide reasonable protection against harmful interference in a residential installation. This equipment generates, uses and can radiate radio frequency energy and, if not in-stalled and used in accordance with the instructions, may cause harmful interference to radio communications. However, there is no guarantee that interference will not occur in a particular installation. If this equipment does cause harmful interference to radio or television reception, which can be determined by turning the equipment off and on, the user is encouraged to try to correct the interference by one or more of the following measures:

- Reorient or relocate the receiving antenna.
- Increase the separation between the equipment and receiver.
- Connect the equipment into an outlet on a circuit different from that to which the receiver is connected.
- Consult the dealer or an experienced radio/TV technician for help.

CAUTION:

Changes or modifications not expressly approved by Elan Home Systems could void the user's authority to operate the equipment



N2154



Purpose of This Manual	1
Organization	1
Safety Information	2
 Chapter 1: Introduction	
The ELAN Story	9
S86A Features	10
System S86A Functions & Indicators	12
Front Panel	12
S86A Front Panel Table.....	12
Rear Panel	13
S86A Rear Panel Table	13
 Chapter 2: S86A System Design Overview	
Introduction	14
Pre-Wire	15
Applications	16
Zone/Sub-Zone Definitions	16
Stereo Zones	17
Stereo Zone w/ Stereo Sub-Zone	18
Stereo Zone w/ Mono Sub-Zone	19
Stereo Zone w/ Multiple Sub-Zones	20
Video Applications	21
 Chapter 3:S86A Connections	
SPP System Precision Panel	22
Connections When Using an ELAN SPP Precision Panel-Rear	24
VIA! Touch Panel Connections	25
Olé Film Interactive Touchpads	27
“A” Punchdown Locations	27
“B” Punchdown Locations-16V	28
“B” Punchdown Locations-12V	29
“C” Punchdown Locations	30
Z•Pad Connections	30
“C” Punchdown Locations	31
IR Receiver Connections	31
Sense Input Connections	31
Programmable Trigger Connections	32
LINK IN/LINK OUT Connections	32
External Power Connections	33
RS-485 Expansion Connections	33
Switches	34
INT 12V-EXT 16V Switch	34
ZNET/VNET Switch	34
SS/SC4-NO SS/SC4 Switch	35

Connections When Using an ELAN SPP Precision Panel-Front	36
VIA!NET Connection	36
EXT IR Connections	36
Sense Input Connections	36
SS/SC4 Connection	37
ZONE 1-8 Connections	37
Triggers Connections.....	38
Power Connections	39
S86A Connections When NOT Using an ELAN SPP Precision Panel	40
Sense Input Connections.....	40
VIA! Touch Panel Connections	41
Olé Touchpad Connections	42
Keypad Connections	42
Programmable Trigger Output Connections.....	43
SYSTEM TRIGGER OUT Connections	43
Additional S86A Connections-With or Without SPP Precision Panel	44
SOURCE IR OUTPUT Connections	44
ALL IR OUT Port Connections	45
Audio/Video Connections	45
Loop Output Connections	46
Advanced Video Switching-Composite Video	47
V8 Video Controller.....	47
VIA!@Quad Video Controller.....	48
Advanced Video Switching-Component Video	49
V85 Component Video Controller	49
Zone Preamp Outputs-Audio	50
Zone Preamp Outputs-Video.....	51
Speaker Outputs	52
ELAN RS-232 Ports	53
SC-4 RS-232 System Controller.....	53
SS1 System Station.....	53
C2 Communications Controller Connections	54
VSE2 Electronic Volume Control Connections.....	55
Multi-Chassis Connections	56
AC Power Connections	59
Chapter 4: Operations and Settings	60
Pull-Open Access Door	60
Unit I.D. Settings	60
Unit I.D. DIP Switches	61
Front Panel LED's	61
Chapter 5: Troubleshooting	62
Appendix A: Specifications	68

Appendix B: Programming	70
Appendix C: RS-232 Serial Control Commands	71
General Information	71
S86A Communication Port Settings	72
RS-232 Commands	73
Appendix D: Rack Mounting	106
Warranty	Back Page



S86A

Integrated Multi-Room A/V Controller

Items in package:

- S86A Integrated Multi-Room A/V Controller
- Power Cord
- Installation Manual

Chapter 1: Introduction

The S86A Integrated Multi-Room A/V Controller is designed to be an affordable, feature rich solution for whole-house audio and video distribution, combining amplification, audio switching, video switching, triggers, and source control options in a combination found in no other product at this price point. The S86A Controller is an eight source, six zone controller with twelve channels of amplification and on-board composite video switching. Up to four S86A Controllers can be linked for a total of twenty-four zones. Controllable by IR or Serial commands, this unit works with ELAN VIA!® Touch Panels, Olé™ Film Interactive Touchpads, Z•Series Keypads, and/or IR receivers, as well as interfacing with the VIA!®-SR1 Sense/Relay Module, and SS1 System Station.

This unit has been designed with ultimate flexibility in mind. Multiple control methods combine with expandability to offer the perfect solution for medium and larger whole-house audio/video and automation control systems, and advanced trigger options allow flexible automation opportunities.

The S86A Controller contains a built-in composite video switcher which facilitates the routing of composite video sources like VCRs, satellite receivers, DVRs, and CCTV cameras throughout the home. Loaded with all the features a custom installer requires, the S86A Controller includes audio/video signal sensing and system-status feedback, eight source-specific IR ports, an IR 'All' port, six Sense Inputs, six Trigger outputs plus a System Trigger output, a Music-On-Hold output, Page/Doorbell audio and Trigger jacks for easy integration with ELAN's C2 Communications Controller, IR Expansion ports, and Serial In/Out ports for RS-232 control. The SPP System Precision Panel makes all system connections quick, neat and reliable!

The ELAN Story

Located in Lexington, KY, USA, ELAN Home Systems has designed innovative multi-room audio/video systems since 1989. ELAN systems were the first to integrate music, intercom and TV distribution features that used the homeowner's stereos, televisions and telephones to create the whole-house entertainment experience. These systems allow people to move from room to room, controlling centrally located equipment with ease.

ELAN's product line includes:

- Power Amplifiers
- Multi-Zone Pre-Amps
- Intelligent Keypads
- In-Wall LCD Color Touch Panels
- Wireless LCD Color Touch Panels
- Film Interactive Touchpads
- In-Wall and In-Ceiling Speakers
- Outdoor Speakers
- System Controllers
- Volume Controls
- Telephone-Based Intercom Controllers
- Video Switchers
- Digital Music and DVD Management Systems
- Satellite Radios
- Accessories for Home Systems Installation

S86A Features

8 Sources

- Connect up to 8 Audio or A/V components.

8 Video Inputs

- Switch independently or in synchronization with audio.

6 Zones

- Each chassis has six zone output capability.

24 Zone Capability

- Link up to 4 S86A Controllers to independently control up to 6, 12, 18 or 24 zones.

Buffered Loop Audio and Video Outputs

- Easily share sources w/ Home Theaters, etc.

Variable & Fixed Zone Preamp Outputs

- Each zone output can be configured for variable or fixed volume for flexible system configuration.

Independent Zone Control of Bass, Treble, and Volume

- Adjust the sound for each zone.

Independent Turn-On Settings for Bass, Treble, Page Volume, & Minimum/Maximum Volume for Each Zone

- Program default values for bass, treble, min & max volume, page volume. Choose preset settings or last used setting each time.

Audio & Video Source Sensing for System Feedback

- Advanced signal sensing for source and zone status feedback and automated sequences.

Input Source Levelling

- Optimize the input level of each audio source for smooth source switching.
- Available for Variable Pre-Amp outputs and speaker outputs (not Fixed-mode Preamp Outputs).

Source-Specific IR Routing/ALL Port

- 8 source-specific IR Output ports
- 1 IR 'ALL' Output port

Full ELAN Control Capability

- Use with any ELAN keypad, touchpad, or LCD touch panel.
- IR or RS-232 Control
- Uses VIA!®TOOLS or ELAN®TOOLS setup software for all programming.

Whole-House Music (WHM)

- Play one source throughout the house with the touch of a button.

Do-Not-Disturb

- Temporarily disable Page, Doorbell AND WHM, in any zone.
6 Sense Inputs
- Trigger complex IR sequences and automated functions using VIA! Touch Panels and Olé Film Interactive Touchpads.

6 Programmable Trigger Outputs/1 System Trigger Output

- Turn on a specific amp channel when a specific zone is activated or turn on the whole amp when any zone in the system is activated.

Rear Panel Expansion Ports

- Easily route IR and RS-485 data between multiple S86A chassis.
Programming and Firmware Download Functions
- Front Panel USB

RMK3 Rack-Mount Kit Available

- Easily mount in a standard equipment rack.

Available in 240 Volt Version**cTUVus Certified, CE[®], and C-tick**

S86A Functions & Indicators

Front Panel

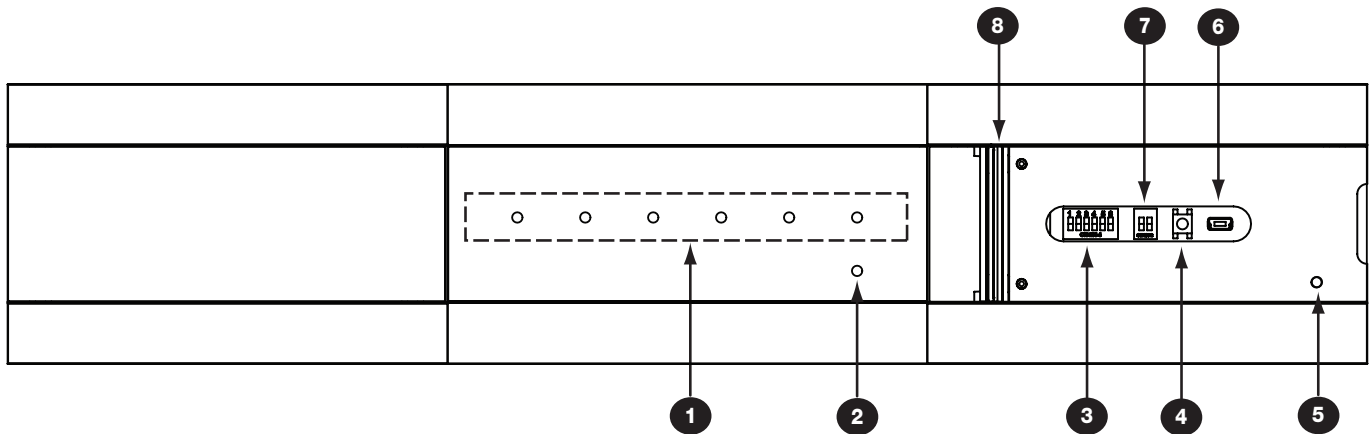

Figure 1-1: S86A Front Panel Controls & Indicators

Item	Name	Item	Name
1	Six Zone Activity LEDs (Blue)	5	Power LED (Blue)
2	IR Activity LED (Green)	6	USB-Mini-B Connection
3	Six Zone Pre-Amp Output Mode DIP Switches	7	Unit ID Expansion DIP Switches
4	IR Learning Button (future use)	8	Access Door (Shown Open)

Table 1-1: S86A Front Panel Controls & Indicators

Rear Panel

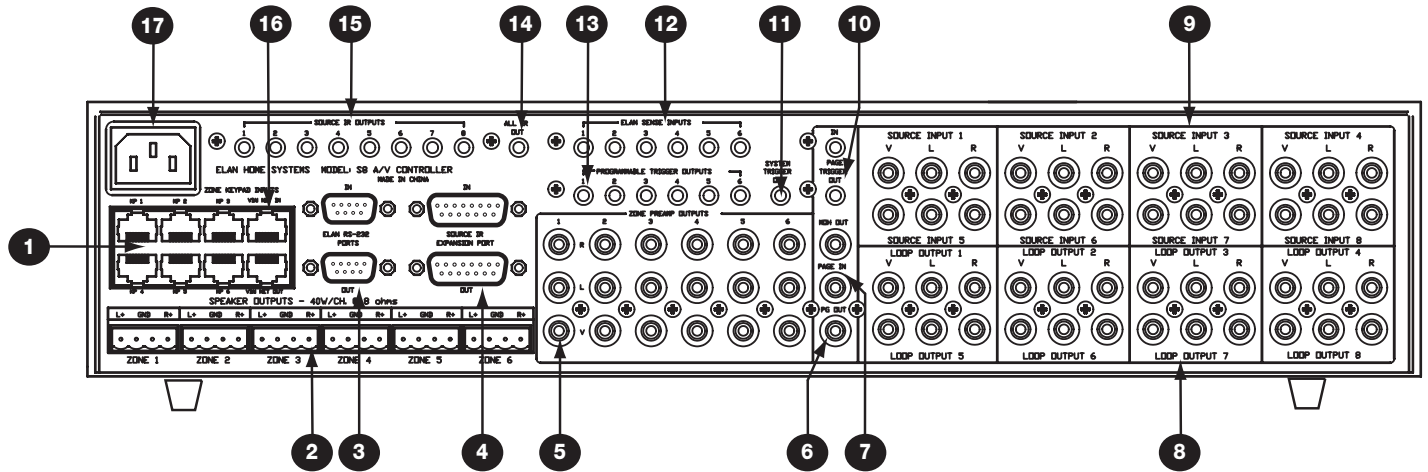

Figure 1-2: S86A Rear Panel Connections

Item#	Name	Item#	Name
1	Zone IR Inputs	10	Page Trigger Input/Output
2	Speaker Outputs	11	System Trigger Output
3	ELAN RS-232 Ports	12	ELAN Sense Inputs
4	Source IR Expansion Ports	13	Programmable Trigger Outputs
5	Zone Pre-Amp Outputs	14	ALL IR Output
6	Music On Hold Output	15	Source-Specific IR Outputs
7	Page Audio Input/Output	16	VIA!NET Input/Output
8	Source Audio/Video Loop Outputs	17	AC Power Connector
9	Source Audio/Video Inputs		

Table 1-2: Rear Panel Connections

Chapter 2: S86A System Design Overview

Introduction

The first step to a good design is to map the system. It is advisable to mark up a copy of the house floor plan with speaker, keypad, touch panel, volume control, and equipment locations etc. Make sure that all locations are decided upon before pre-wiring commences so that all necessary wiring and installation hardware is in place. This unit will be interfacing with other components such as amplifiers, source components, communications controllers, serial controllers, and user interfaces, so it is essential that ALL system components are accounted for prior to the pre-wire stage.

Secondly, make a detailed list of all components. Include source equipment, keypads, touch panels, volume controls, amplifiers, communications gear and the S86A itself. Be sure to include necessary electrical boxes, structured wiring enclosures, telephone lines, rough-in brackets, patch cords, power supplies, etc.

Rack Mounting

Use ELAN's RMK3 Rack-Mount Kit when installing the S86A in an equipment rack. The RMK3 is designed to facilitate mounting ELAN dual rack-space integrated Multi-Room Controllers and Amplifiers into standard 19" equipment racks in order to provide optimum air flow and heat dispersion for these units. The RMK3 will take up three rack spaces when installed.

Pre-Wire

This section will explain the specifics of pre-wiring for an S86A system. Care should be taken at this stage to ensure a properly operational system.

Most system wiring is "home-run" from the device being installed (a keypad, for example) back to the equipment location.

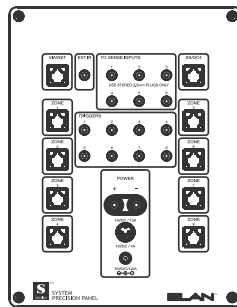

ELAN
Precision Panels
save time
and make sense
out of complex
wiring jobs!

Table 2-1 displays the ELAN pre-wiring recommendations for connections to the S86A

Item	Description
VIA! Touch Panels	Cat-5 network cable 16-18 AWG 2 conductor wire (On runs greater than 100 feet) RG-6 or RG-59 Coaxial cable
Olé Film Interactive Touchpads	Cat-5 network cable
ELAN Keypads	Cat-5 network cable
IR Receivers	Cat-5 network cable
Volume Controls	Cat-5 network cable 16-18 AWG 2 conductor wire Use stranded, twisted pair speaker wire between amplifiers and volume controls, and between volume controls and speakers. Use Cat-5 to power electronic volume controls and for volume control override when used with a C2 Communications Controller.
Speakers	16-18 AWG speaker wire Use stranded, twisted pair speaker wire between amplifiers and speakers.
Remotely Located Sources	Cat-5 RG6 or RG59 coax (if necessary) Remotely located sources connect to the S86A using an ELAN RSWP Remote Source Wall Plate Kit with Cat-5.
C2 Communications Controller	Cat-5 18 AWG When using an ELAN C2 Communications Controller, run Cat-5 for telephones and door stations. See the C2 Installation Manual for details.
Serial Devices	Cat-5 or Serial Cable Run Cat-5 or serial cables between RS-232 controllers and the S86A.
Sense Inputs	Cat-5 (3 conductors used) Use Cat-5 to extend sensor leads, if necessary.
System Video	RG-6 coax for RF or base-band video. RG-59 coax for base-band video only. Use coaxial cable to distribute video to TVs and VIA! Touch Panels throughout the house.
System Audio	RCA Interconnect Cables

Table 2-1: ELAN Pre-Wiring Recommendations

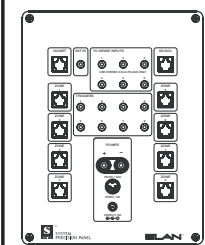

ELAN Precision Panels save time and make sense out of complex wiring jobs!

Applications

This section describes typical applications using the S86A in audio/video distribution and automation installations. These are all basic in nature and should be used for guideline purposes only. Each application can be augmented as needed for individual circumstances. This section is for overall design purposes. Please see Chapter 3: S86A Connections for specific wiring configurations.

Zone/Sub-Zone Definitions

A zone is defined as an area within a system that has independent source selection ability. A zone may be one room, or several combined areas. A sub-zone is a part of a zone - it shares source selection - but has independent control of volume. Typically, sub-zones use volume controls for volume up/down. Figure 2-1 shows a typical zone/sub-zone example

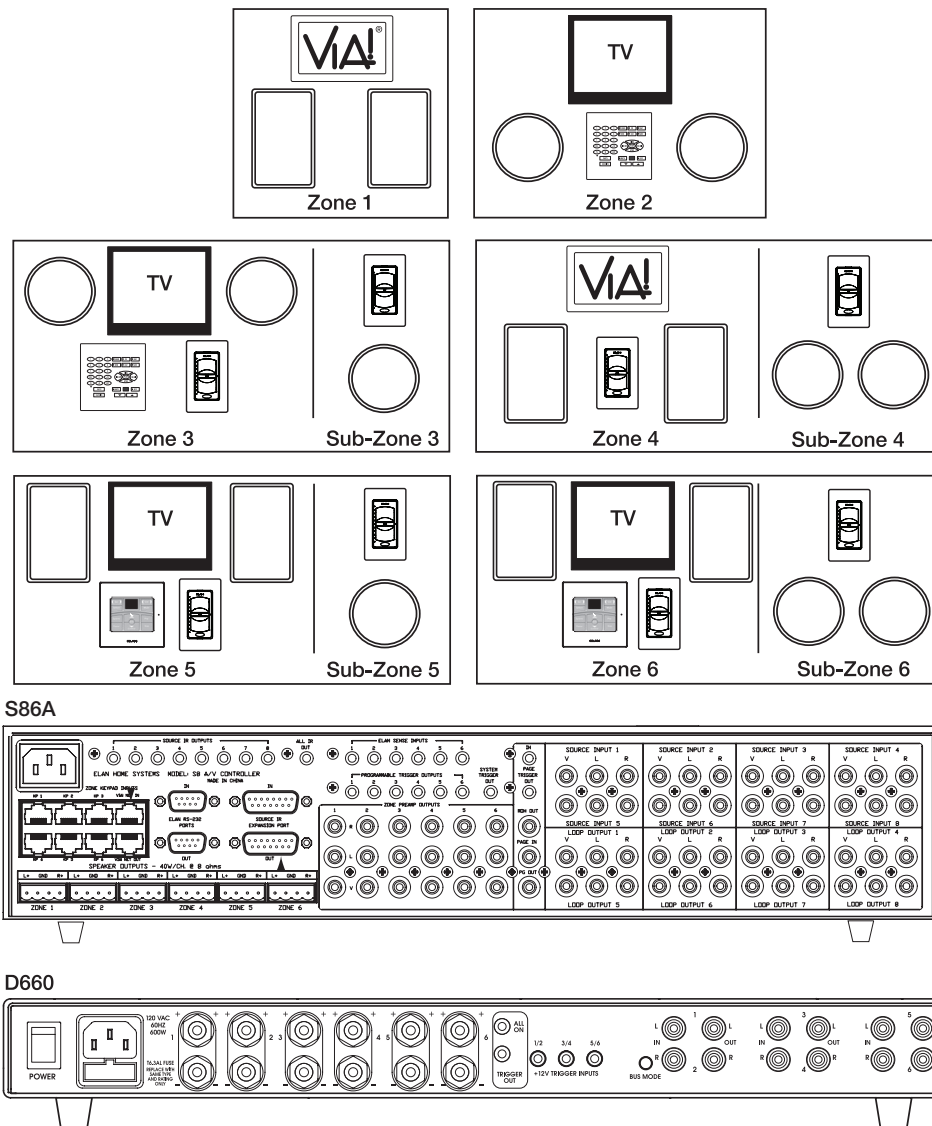
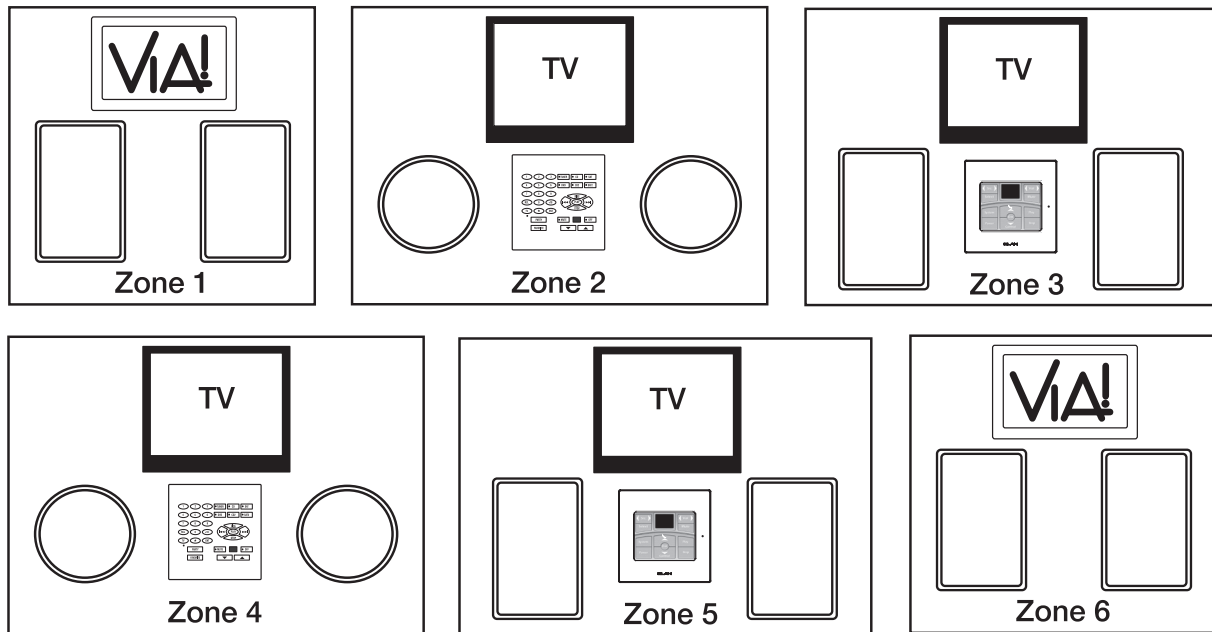

Figure 2-1: Zone/Sub-Zone Definitions

Stereo Zones

To create an independent stereo zone, simply connect the S86A's Speaker Outputs to a pair of speakers. Make sure to take into account the amplifier's 8 Ohm minimum impedance when choosing and configuring speakers. Volume will be controlled using IR or RS-232 commands at pre-amp level. Any and all speakers connected to these channels will ramp volume up/down together. Use a VIA! Touch Panel, keypad, Olé touchpad or hand-held remote control to control functions (including volume) in zones with this configuration. **Figure 2-2** shows a typical example of independent stereo zones.



S86A

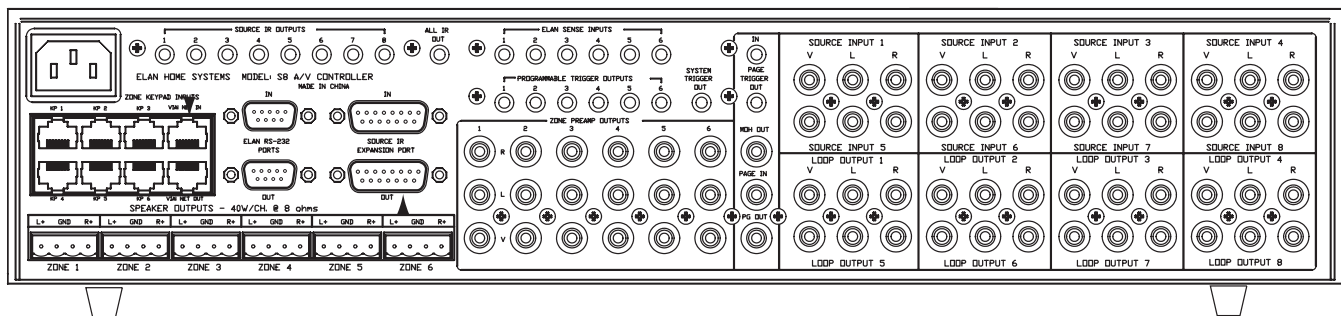
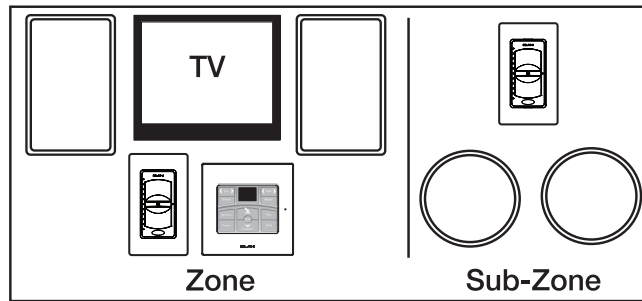

Figure 2-2: Stereo Zones

Stereo Zone w/ Stereo Sub-Zone

Connect the Zone Pre-Amp Output to a pair of amp channels. Set the DIP switch for that zone to FIXED. Use an impedance matching volume control on the external amplifier's speaker outputs to maintain independent volume control capabilities in each room. The main zone ramps volume up/down at preamp level using IR or RS-232 commands sent from a keypad, Olé Touchpad, or VIA! Touch Panel, while the sub-zone ramps volume up/down at speaker level using the volume control. If using ELAN electronic volume controls, system and source control is possible using a hand-held remote control. This application uses one pair of amplifier channels from the S86A and one pair of amp channels from the external amplifier. Many areas of the home are ideal for zone/sub-zone configuration. Examples include Master Bedroom/Master Bath or Kitchen/Dining Area. *Figure 2-3* shows a typical example showing a stereo zone with a stereo sub-zone.



S86A

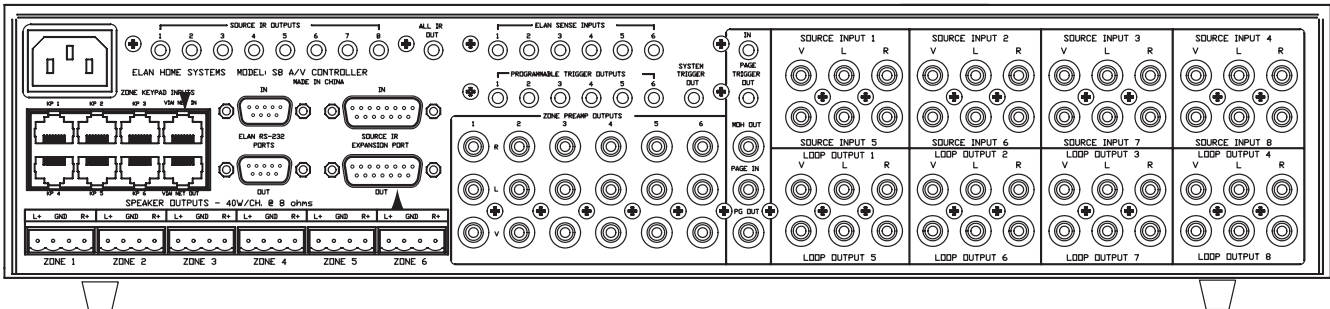

A12

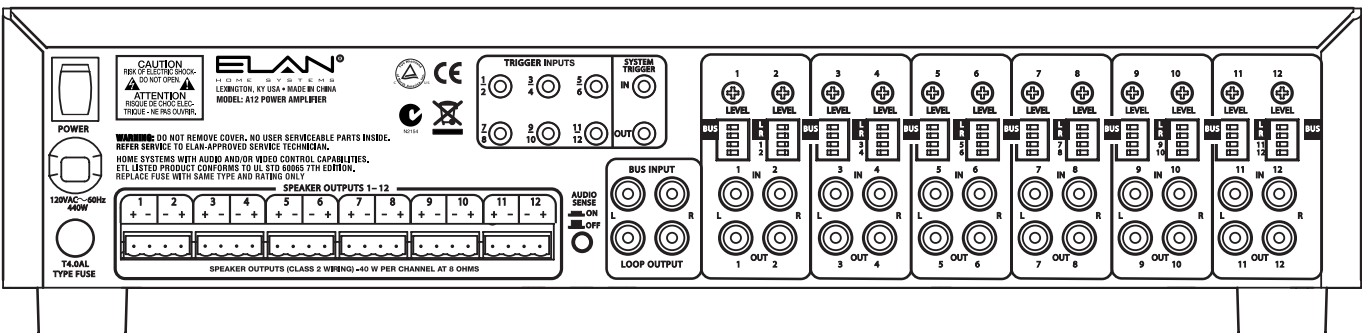
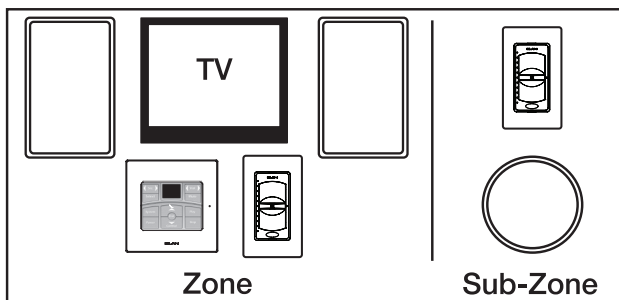

Figure 2-3: Stereo Zone/Stereo Sub-Zone

Stereo Zone w/ Mono Sub-Zone

Rooms with no definite listening area (kitchens, hallways, L-shaped rooms, for example) are ideal for mono configuration. Use a male-to-male RCA “Y” cable to combine the Left and Right Zone Pre-Amp Outputs to create a mono sub-zone. The main zone ramps volume up/down at preamp level using IR or RS-232 commands sent from a keypad, Olé Touchpad, or VIA! Touch Panel, while the sub-zone ramps volume up/down at speaker level using a volume control. Although the subzone has independent control of volume, it always shares the same source with the main zone. If using an ELAN electronic volume control in the sub-zone, system and source control is possible using a hand-held remote control. *Figure 2-4* shows a typical example showing a stereo zone with a mono sub-zone.



S86A

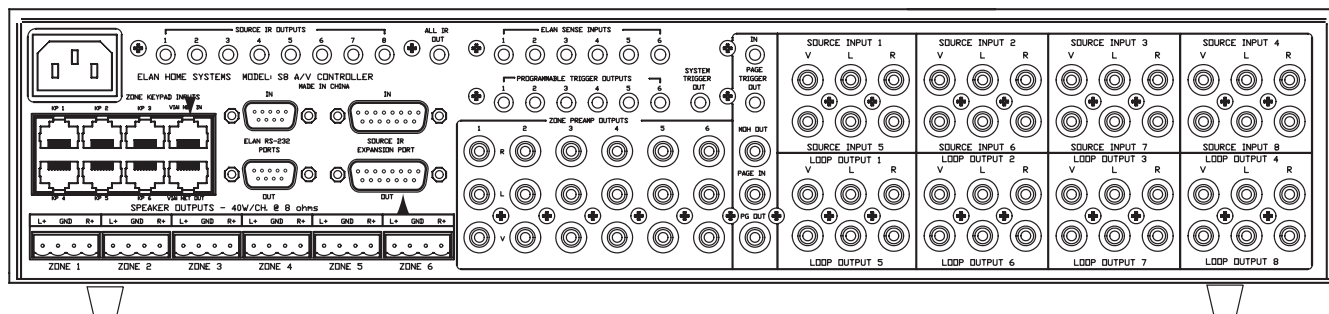

A12

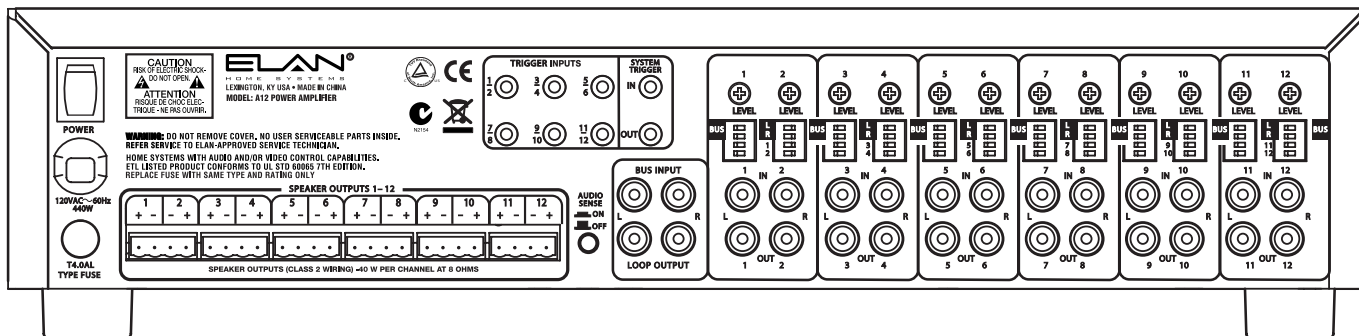

Figure 2-4: Stereo Zone/Mono Sub-Zone

Stereo Zone w/ Multiple Sub-Zones

This application is ideal for large areas where independent volume control is needed in separate locations. Volume is controlled in a variable zone using keypads, Olé Touchpads, IR sensors, or VIA! Touch Panels. Sources for the entire zone are selected and controlled from this same keypad, touchpad, IR sensor, or touch panel.

Connect the speaker outputs of the S86A to a pair of speakers in the main zone. Volume in this area will ramp up/down using IR or RS-232 commands from the zone's keypad, touchpad, IR sensor, or touch panel. Connect the Zone Pre-Amp Outputs of the S86A to the inputs of an external amplifier. Connect the speaker outputs of the external amp to two impedance matching volume controls, then to two pairs of speakers. Set the DIP switch for the zone to FIXED. The volume controls will ramp volume up/down only for the speakers that they are connected to, giving separate volume control in each areas of the zone. The volume up/down commands from the keypad, touchpad, IR sensor, or touch panel will have no effect in the sub-zones. For mono sub-zones, use an RCA "Y" cable from the Loop Output of the amplifier to an additional Zone Input of the amplifier. This application provides a stereo zone (connected to the S86A's built-in amp), a stereo sub-zone (connected to a pair of external amplifier channels) and a mono sub-zone (connected to an additional channel of the external amplifier). If using electronic volume controls, a hand-held IR remote control can be used for source select and control in the sub-zone areas. If using rotary volume controls, all source selection and control must be done from the keypad, touchpad, IR sensor, or touch panel. This application has cost-saving advantages. Only two pairs of amp channels are needed (one pair from the S86A's built-in amp, and one pair from the external amplifier). Mono sub-zones require only one amplifier channel per sub-zone area. If using electronic volume controls, independent volume up/down is available as well as source selection and control. See *Figure 2-5* for an example of a stereo zone/multiple sub-zone application.

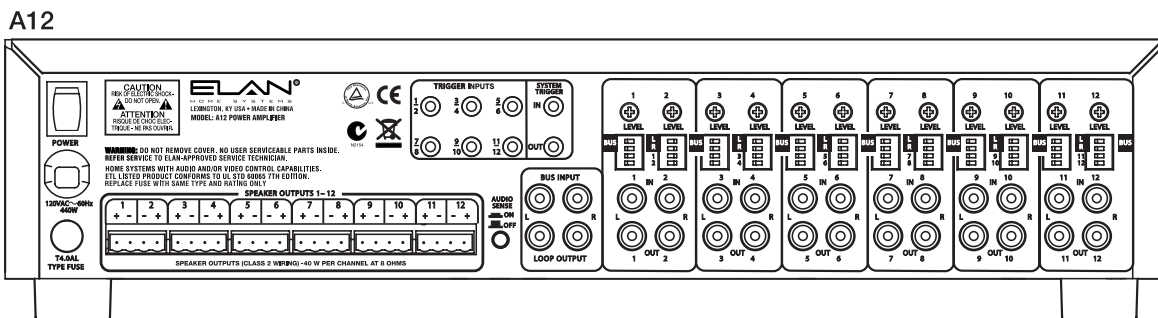
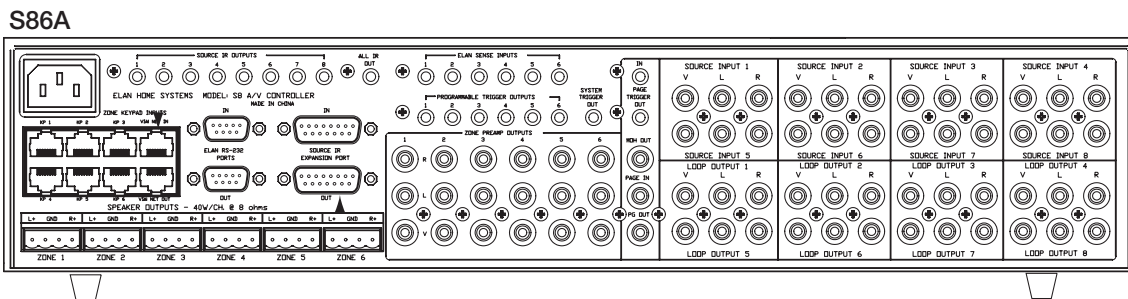
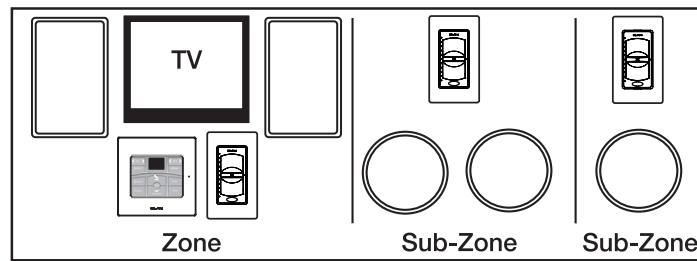
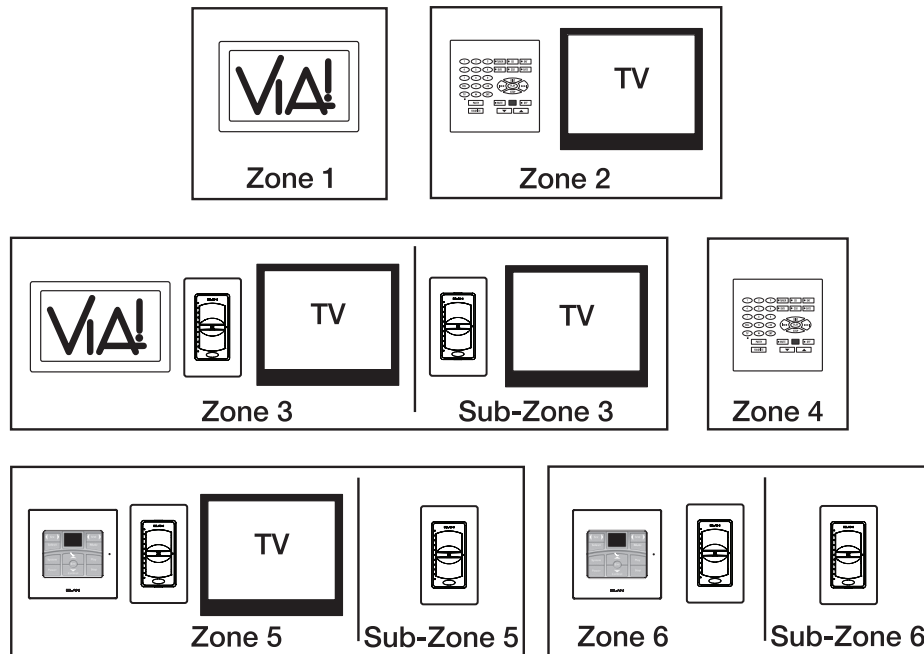

Figure 2-5: Stereo Zone/Multiple Sub-Zones

Video Applications

The S86A has built-in Composite Video switching capabilities that allow for multiple configuration options. Each audio Source Input has a corresponding Video Input, so that up to eight video sources can be utilized. Each Loop Output also has a corresponding video output, for applications that share sources, or for multi-chassis S86A configurations. Each Zone Preamp Output has a video output, so that up to six TVs, VIA! Touch Panels, or monitors can receive video from any Source Input

Audio and video can track each other on a one-to-one, source-for-source, zone-for-zone basis, or can be programmed for independent switching. This will allow multiple video inputs to be assigned to a single source, or multiple video outputs to be routed to a single zone. **Figure 2-6** shows a six zone system with certain zones that have multiple video outputs, other zones with a single video output, and others with no video outputs. See **Chapter 3: Connections** for specific examples of Source Video Input applications.



S86A

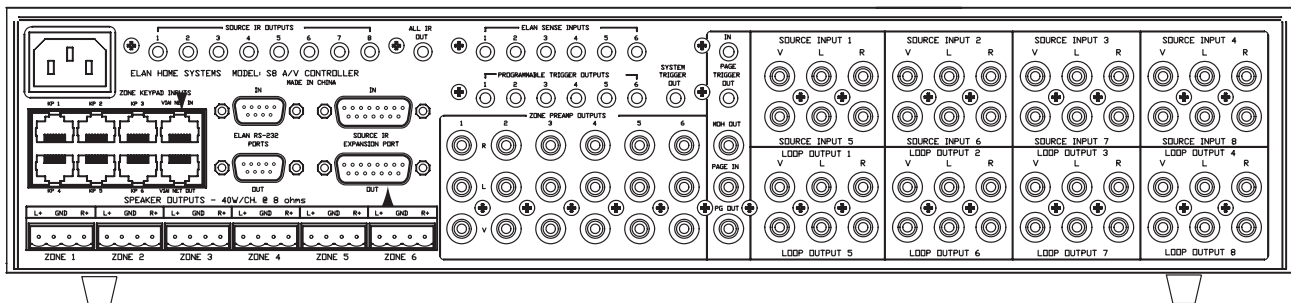

Figure 2-6: Video Zone Output Application Example

Chapter 3: S86A Connections

SPP System Precision Panel

The SPP System Precision Panel is designed to be the connectivity solution for all ELAN C Series Multi-Room Controllers. The rear panel of the SPP features a neatly laid out array of all the 110 punch-downs necessary to ensure quick, reliable connection of keypads, touch panels, touchpads, Sense Inputs and Triggers in every zone. Clearly labeled overlays show the color-code and function of every connection for the S86A Controller as well as other ELAN Multi-Room Controllers.

Note: Each S86A chassis in a multi-chassis system requires its own SPP Precisionpanel.

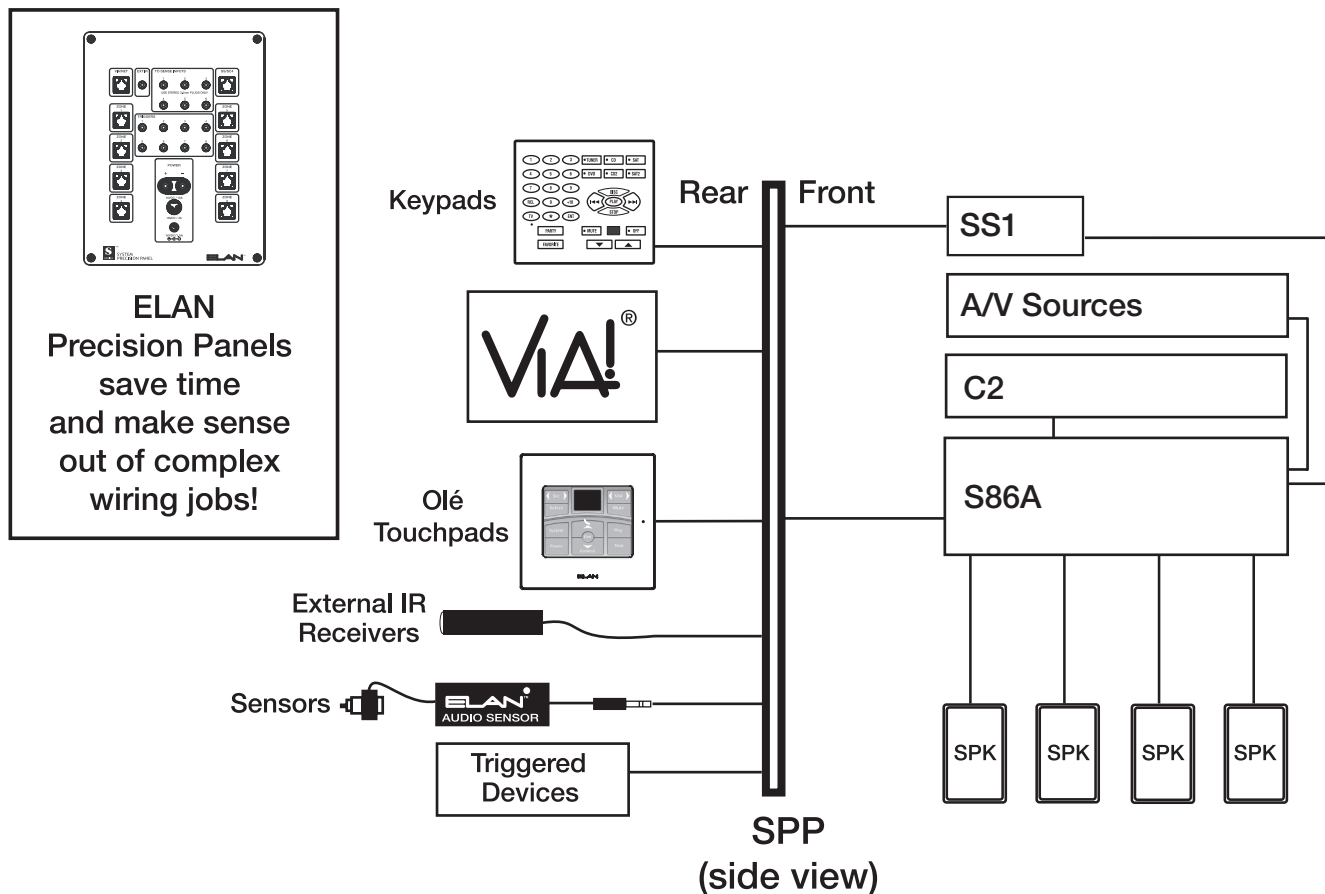

Figure 3-1: SPP Connection Overview

Keypads, touch panels and touchpads connect to the back of the SPP Precision Panel. RJ-45 connectors on the front provide an easy interface to the Zone IR Inputs on the S86A Controller. Use one or two meter RJ-45-to-RJ-45 interconnect cables for reliable connections. Six Sense Input jacks use stereo 3.5mm interconnect cables to go directly to the Sense Inputs on the S86A. The front panel also features DC power jacks for 1.5A, 4A and 10A VIA! power supplies. The front panel of the SPP is removable, to facilitate easy access when connecting wires. New-construction brackets are available, or the SPP can easily be retro-fitted using the four clamping legs attached to the frame, which secure the panel securely to drywall. Additional panels are required for systems with two, three or four S86A Controllers (one SPP per chassis).

Each SPP punchdown location can contain two wires; one on top of the other. Use the included 110 punch-down tool to make connections to the rear panel of the SPP. Make sure to use the included punchdown caps so that connections do not inadvertently become loose! Use the included Rear Panel Overlay to simplify punchdowns. The SPP Precision Panel includes two Overlays - choose the one labelled "S86". This Overlay provides a color-by-color punchdown template specifically for the S86A Multi-Room Controller.

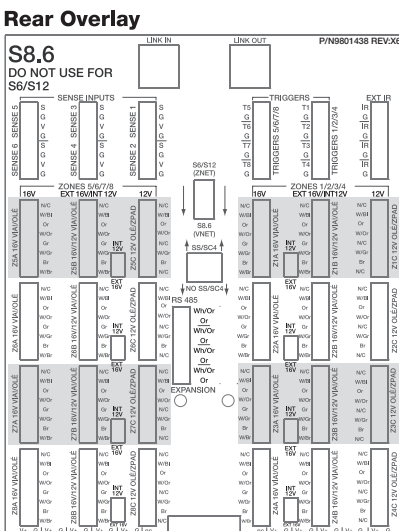
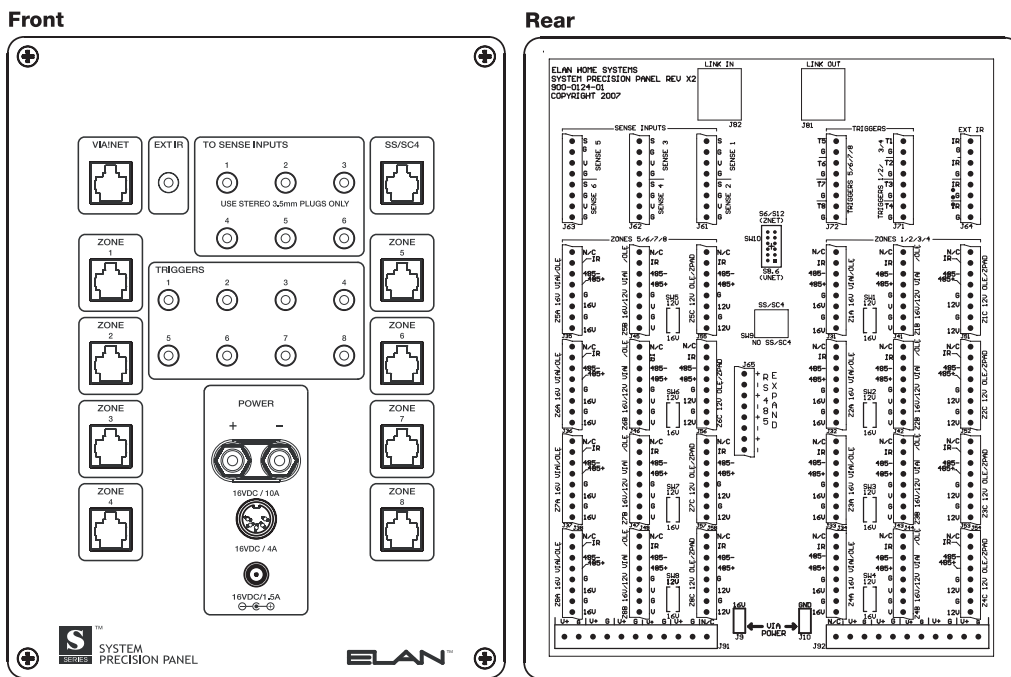

Figure 3-2: SPP Precision Panel

VIA! Touch Panel Connections

The S86A is designed to work flawlessly with ELAN VIA! Touch Panels. VIA! Touch Panels require ELAN 16 Volt DC power supplies. Use the PWR10 16V/10A power supply to power up to ten VIA! Touch Panels. Use the PWR4 16V/4A power supply to power up to 4 VIA! Touch Panels. Use the PWR1 16V/1.5A power supply to power a single touch panel.

When using a VIA! Valet 10.0 Tabletop/Under-Cabinet Color Touch Panel, a PVIA1 Valet Wall Plate must be used. One PVIA1 Wall Plate is included with each VIA! Valet. The installer has the option of using the included PVIA1 power supply, or one of the other 16V power supplies to provide power to the Valet.

VIA! Touch Panels punch-down to the rear of the SPP at two locations, depending on system configuration. These locations are labelled “ZXA 16V VIA!/OLÉ” and “ZXB 16V/12V VIA!/OLÉ” where “X” corresponds to the zone that the touch panel(s) will control. Two touch panels can connect to each punch-down location for each zone. If using more than 2 touch panels per location, make connections off of the SPP and use jumper wires to punch-down to the correct location. **Figure 3-4** shows the correct wiring for one touch panel in Zone 1 connected to the “A” location and utilizing 16VDC power from the PWR1, PWR4, or PWR10 power supply connected to the front of the SPP.

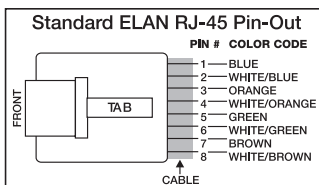
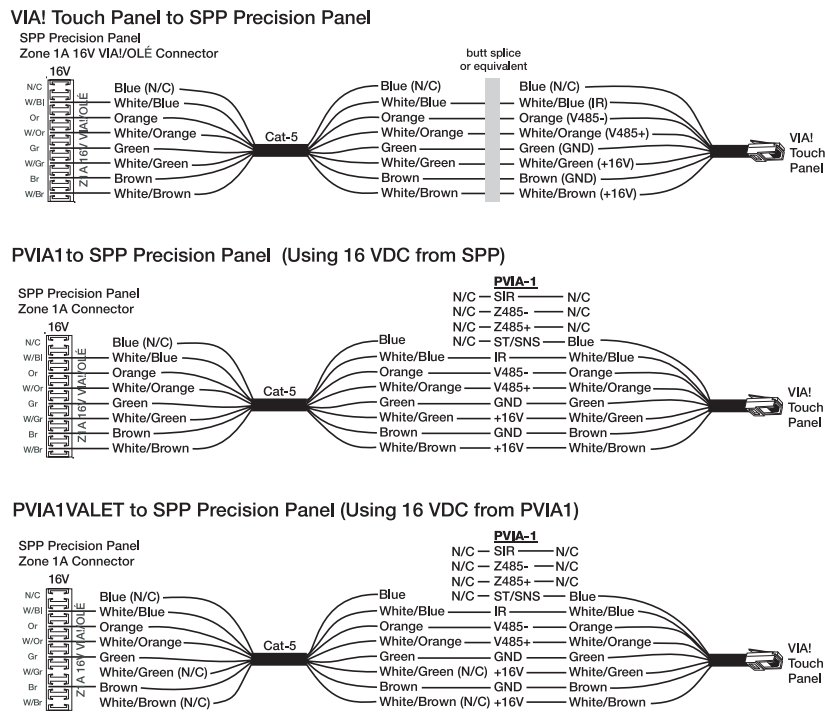

When connecting a PVIA1 Valet Wall Plate to the SPP, use either the included PVIA1 power supply connected to the PVIA1 Wall Plate, or a PWR1 or PWR4 or PWR10 power supply connected to the SPP.

DO NOT USE BOTH POWER SUPPLIES!

Figure 3-4: VIA! Touch Panel Connections

Figure 3-5 shows VIA! Touch Panel connections when the “B” punch-down location is used.

Note: Place the “INT 12V/EXT 16V” switch in the DOWN (“EXT 16V”) position for this application. This allows the external 16VDC power from the PWR1, PWR4, or PWR10 power supply connected to the front of the SPP to reach the touch panel(s).

Note: Refer to Figure 3-4 for VIA! Valet6.4 connectivity. The “INT 12V/EXT 16V” switch will be in the “EXT 16V” position as shown in Figure 3-4.

VIA! Touch Panel to SPP Precision Panel

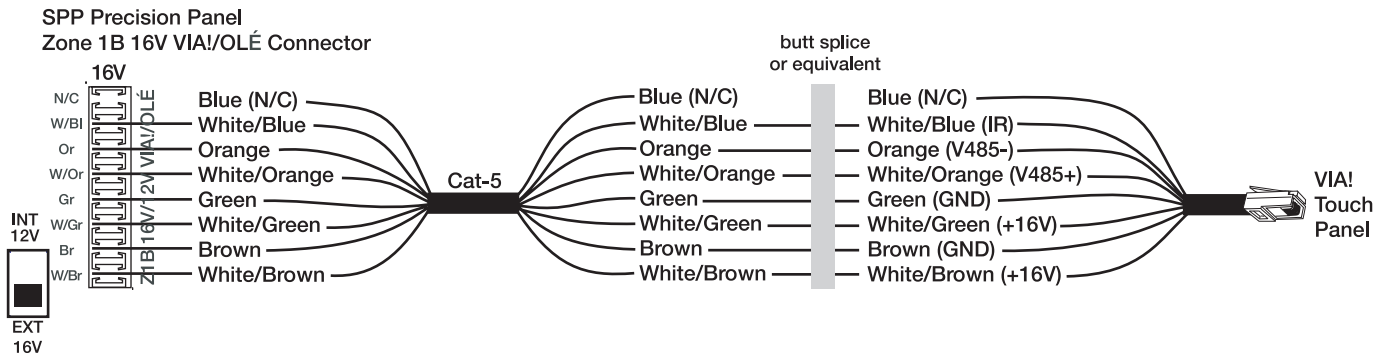

Figure 3-5: VIA! Touch Panel Connections

Olé Film Interactive Touchpads

Olé Film Interactive Touchpads punch-down to the rear of the SPP at three locations, depending on system configuration. These locations are labelled “ZXA 16V VIA!/OLÉ”, “ZXB 16V/12V VIA!/OLÉ” and “ZXC 12V OLÉ/ZPAD” where “X” corresponds to the zone that the touchpad(s) will control. Two touchpads can connect to each punch-down location for each zone. If using more than 2 touchpads per location, make connections off of the SPP and use jumper wires to punch-down to the correct location.

Note: Whenever Olé Touchpads are used with the S86A Controller, set the switch on the rear of the touchpad to the “VIA!NET” position.

“A” Punchdown Locations

Figure 3-6 shows connectivity to the “A” location and utilizing 16VDC power from a PWR1, PWR4, or PWR10 16VDC power supply connected to the front of the SPP.

Note: The “A” punchdown location is always connected to the external 16VDC power from a PWR1, PWR4, or PWR10 16VDC power supply connected to the front of the SPP.

Olé Touchpad to SPP Precision Panel (Using 16 VDC from PWR1, PWR4, or PWR10)

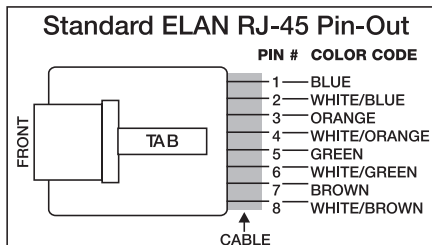
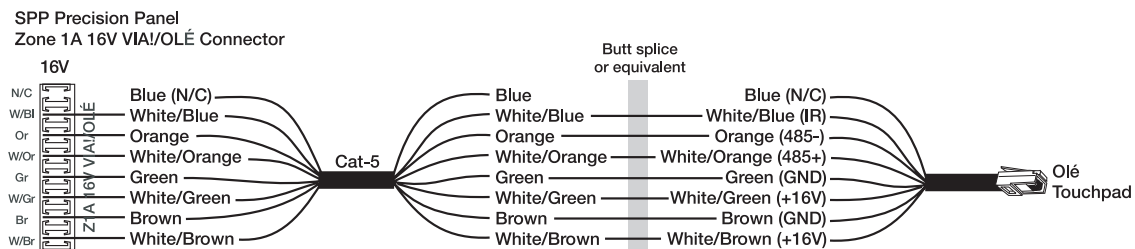

IMPORTANT NOTE
Olé Touchpads

Use the correct power supply connected to the front of the SPP for the number or Olé Touchpads and VIA! Touch Panels in the system.

Olé = 150mA
VIA! = 1A

PWR1 = 1A
PWR4 = 4A
PWR10 = 10A

Figure 3-6: Olé Touchpad “A” External 16VDC Connections

“B” Punchdown Locations-16V

Figure 3-7 shows connectivity to the “B” location and utilizing 16VDC power from a PWR1, PWR4, or PWR10 16VDC power supply connected to the front of the SPP.

Note: Place the “INT 12V/EXT 16V” switch in the DOWN (“EXT 16V”) position for this application.

Olé Touchpad to SPP Precision Panel (Using 16 VDC from PWR1, PWR4, or PWR10)

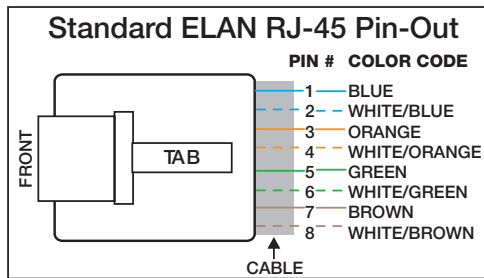
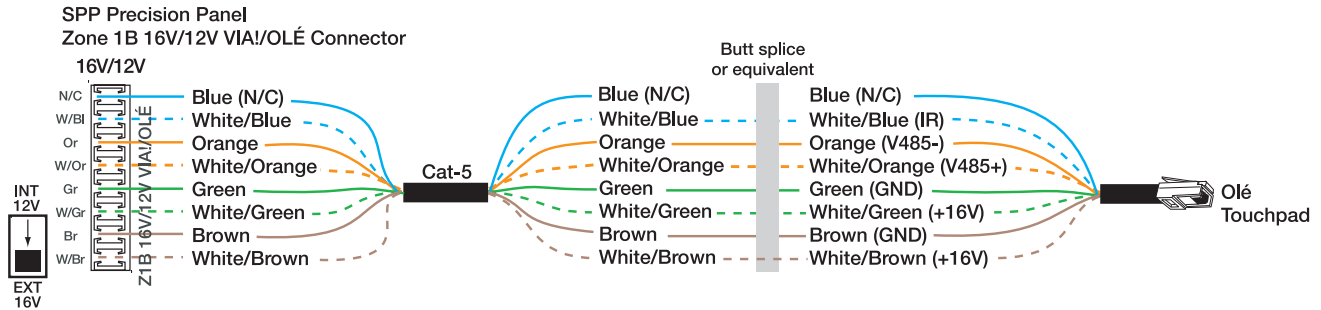

IMPORTANT NOTE Olé Touchpads

Use the correct power supply connected to the front of the SPP for the number or Olé Touchpads and VIA! Touch Panels in the system.

Olé = 150mA
VIA! = 1A

PWR1 = 1A
PWR4 = 4A
PWR10 = 10A

Figure 3-7: Olé Touchpad “B” External 16VDC Connections

“B” Punchdown Locations-12V

The SPP Precision panel has the ability to connect touchpanels, keypads and Olé Touchpads in various combinations in each zone. The “B” punchdown location can either pass 12VDC power from the S86A Controller (Internal Power) or 16VDC from a power supply connected to the front of the SPP (External). *Figure 3-8* shows connectivity to the “B” location and utilizing internal 12VDC power from the S86A Multi-Room Controller.

Note: Place the “INT 12V/EXT 16V” switch in the UP (“INT 12V”) position for this application.

Olé Touchpad to SPP Precision Panel (Using 12 VDC from S86)

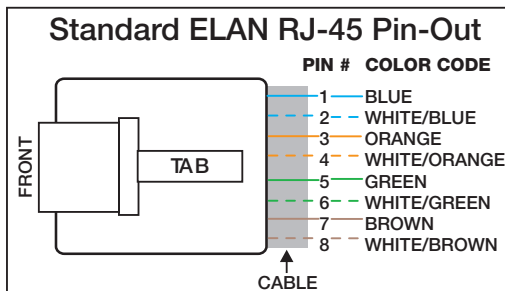
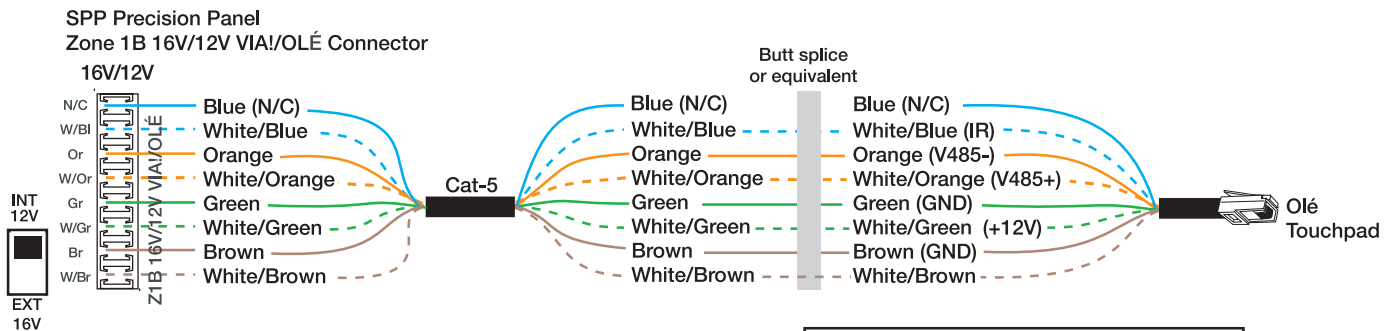

IMPORTANT NOTE
Olé Touchpads, Keypads
VSEs, & IR

Each ZONE INPUT
RJ-45 Jack on the S86A
Provides 12VDC 300mA.

When using the internal 12VDC power from the S86A, you may choose to load each of the S86A's ZONE INPUTS with any combination of Olé Touchpads, IR Receivers, or Electronic Volume Controls as long as the total current consumption **DOES NOT EXCEED 300mA.**

Olé = 150mA
Keypad w/IR Tube = 65 mA
Z•025 = 85mA
Electronic Volume Control = 40mA
Additional IR Receivers = 10mA

Figure 3-8: Olé Touchpad “B” Internal 12VDC Connections

“C” Punchdown Locations

Figure 3-9 shows connectivity to the “C” location and utilizing internal 12VDC power from the S86A Multi-Room Controller.

Olé Touchpad to SPP Precision Panel (Using 12 VDC from S86)

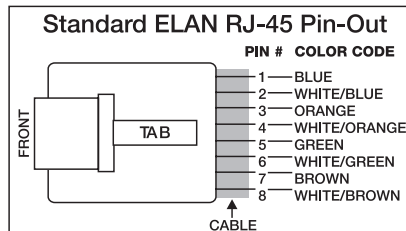
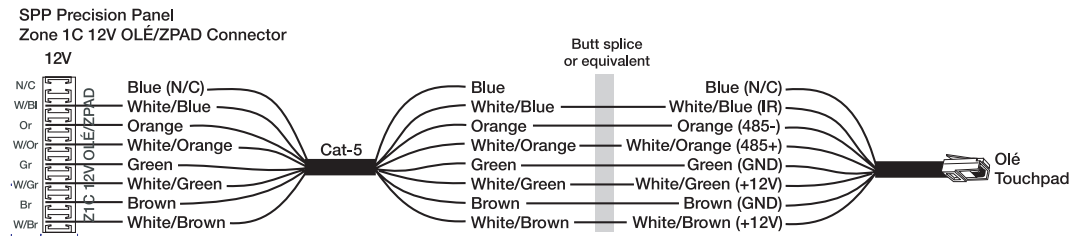

IMPORTANT NOTE
Olé Touchpads, Keypads
VSEs, & IR

Each ZONE INPUT
RJ-45 Jack on the S86A
Provides 12VDC 300mA.

When using the internal 12VDC power from the S86A, you may choose to load each of the S86A's ZONE INPUTS with any combination of Olé Touchpads, IR Receivers, or Electronic Volume Controls as long as the total current consumption **DOES NOT EXCEED 300mA.**

Olé = 150mA
 Keypad w/IR Tube = 65 mA
 Z•025 = 85mA
 Electronic Volume Control = 40mA
 Additional IR Receivers = 10mA

Figure 3-9: Olé Touchpad “C” Internal 12VDC Connections

Z•Pad Connections

“C” Punchdown Locations

It is possible to use ELAN Z•Pad keypads as zone controllers in an S86A-based system. These keypads will control IR sources and S86A Controller function, but they WILL NOT receive RS-485 status feedback. This means that source selection status, shared source status, etc. will not be available to these keypads. Source selection and control are enabled and will function correctly.

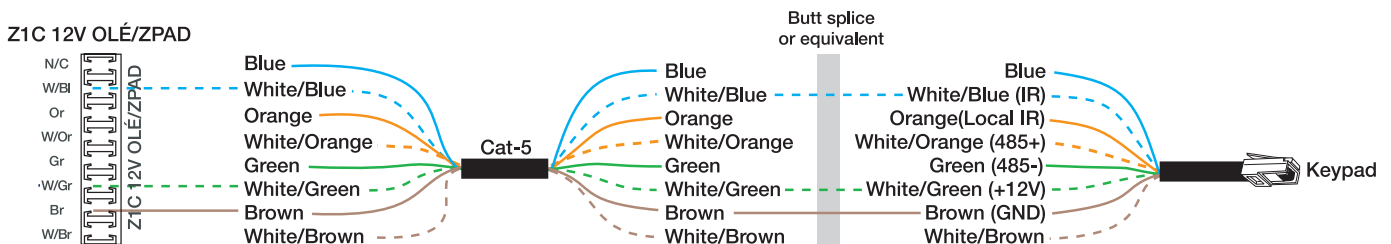

Figure 3-10. Z•Pad Connections

Note: ELAN Z PAD keypads will NOT receive status feedback when connected to the S86A.

IR Receiver Connections

Stand-alone IR receivers for use with hand-held remotes can easily connect to the SPP “C” punchdown locations. Connect +12V, IR, and GND to the specific zone that is to be controlled.

SPP to IR Receiver Connections

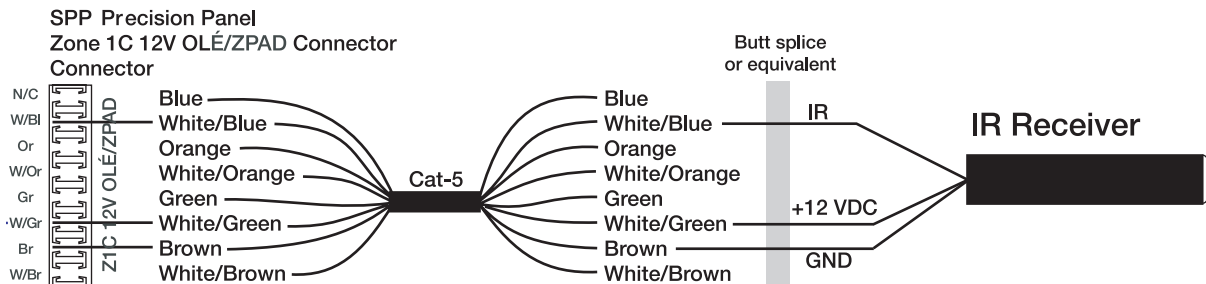

Figure 3-11: IR Receiver Connections

Sense Input Connections

The Sense Trigger Inputs of the S86A are primarily for use with VIA! Touch Panels and Olé Touchpads. An ELAN™SENSE Sensor can be connected that will cause VIA! Touch Panels and Olé Touchpads to execute IR or serial commands. Use VIA!TOOLS or ELANTOOLS setup software to program Trigger Input functionality. Wiring the Sense Inputs consists of punching down Voltage (V), Sense (S), and Ground (G) as shown in Figure 3-12.

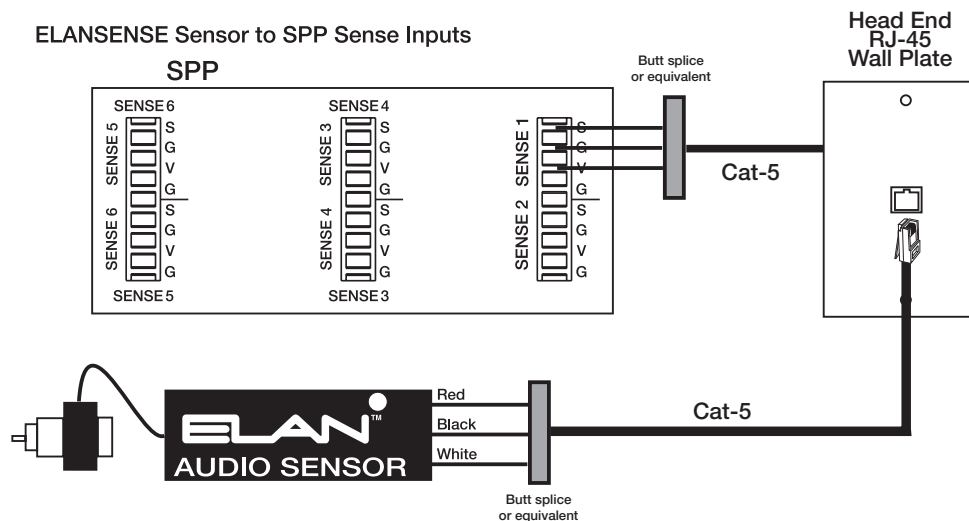

Figure 3-12: Sense Input to SPP Connections

ELANSENSE Sensors provide for a multitude of automation requirements:

- Audio Sensor: Detects line-level audio utilizing an RCA adaptor.
- Video Sensor: Detects Composite video utilizing an RCA adaptor.
- Light/LED Sensor: Detects ambient light or multi-color LEDs.
- Contact Closure Sensor: Detects closed-contact ON/OFF status.
- Current/Magnetic Sensor: Detects electrical current through power cords or magnetic flyback.
- Voltage Sensor: Detects 3-24 Volts AC or DC. Doorbell Sensor: Detects multiple doorbell signals for advanced switching functionality.

Programmable Trigger Connections

Devices that are remotely located can utilize the SPP's TRIGGERS Connections in order to receive signals based on zone activation or system activation. The Programmable Trigger Outputs can be controlled using IR or Serial Commands. Examples include remotely located amplifiers and/or power controllers.



Figure 3-13: Programmable Trigger Connections

LINK IN/LINK OUT Connections

Use the LINK IN and LINK OUT RJ-45 connectors to link multiple S86A chassis and multiple SPP Precision Panels. Use an RJ-45 to RJ-45 Interconnect cable from the LINK IN jack of the first SPP Panel to the LINK IN jack of the second SPP Panel and so on.

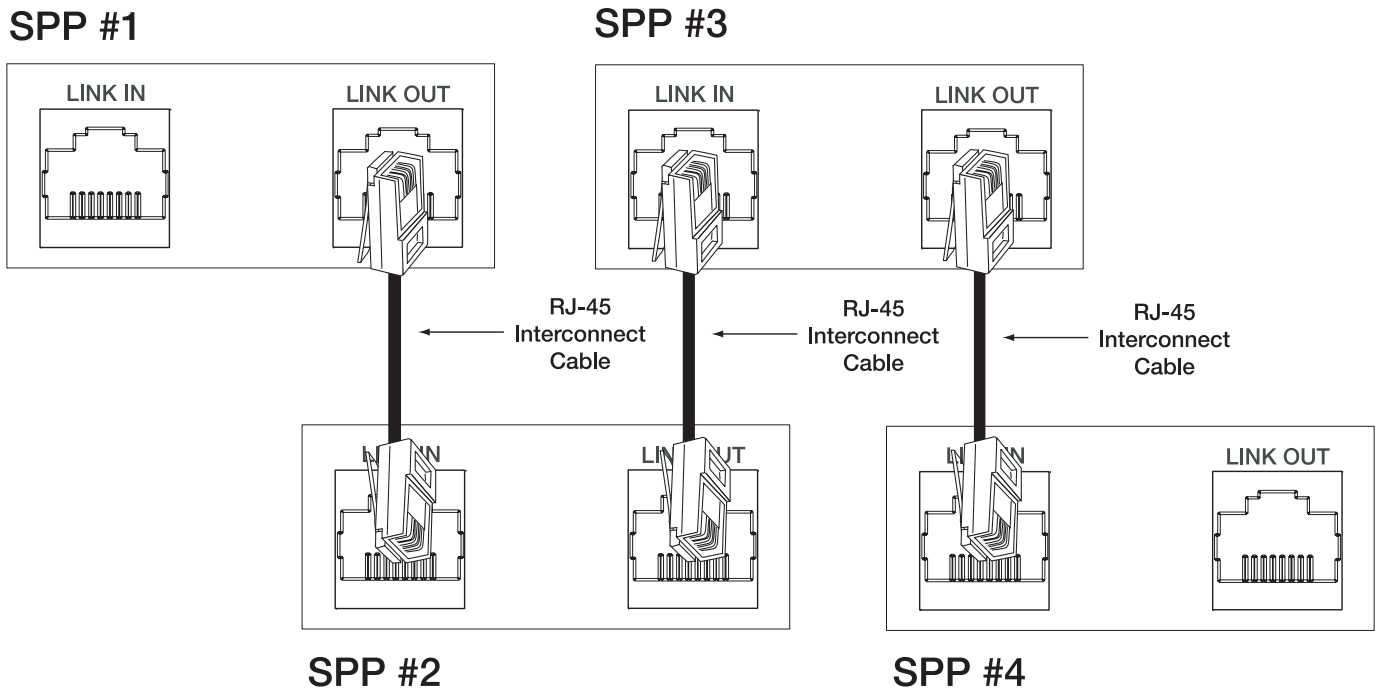

Figure 3-14: Link In/Link Out Connections

External Power Connections

Use the V+ and G screw terminal connections at the bottom edge of the SPP Precision Panel to connect 2 conductor wires (14-18AWG) to power VIA! Touch Panels that DO NOT use the Cat-5 power wiring option and DO use the external power connector located on the touch panel. This application is typically used for long wire runs greater than 110 feet in length. It is not necessary to use both the Cat-5 power connection (located on the ZONE punchdown locations) and the External Power connectors described here.

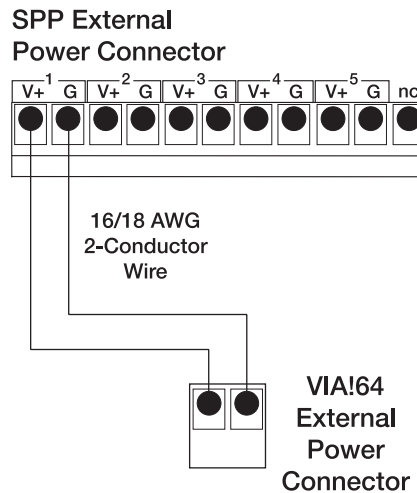

Figure 3-15: External Power Connections

RS-485 Expansion Connections

The RS-485 EXPANSION punchdown connectors channel RS-485 signals (VNET) generated by the multi-room controller. The RS-485 information sent to these punchdowns is identical to that sent to the ZONE locations (Z#A, Z#B, and Z#C). The RS-485 EXPANSION locations simply allow additional punchdown positions and typically WILL NOT be needed when installing touch panels, touchpads, and keypads in an S86A system.

Note: The S86A Controller, generates VNET information for status feedback. Make sure to set the ZNET/VNET switch to the VNET position in any S86A-based system.

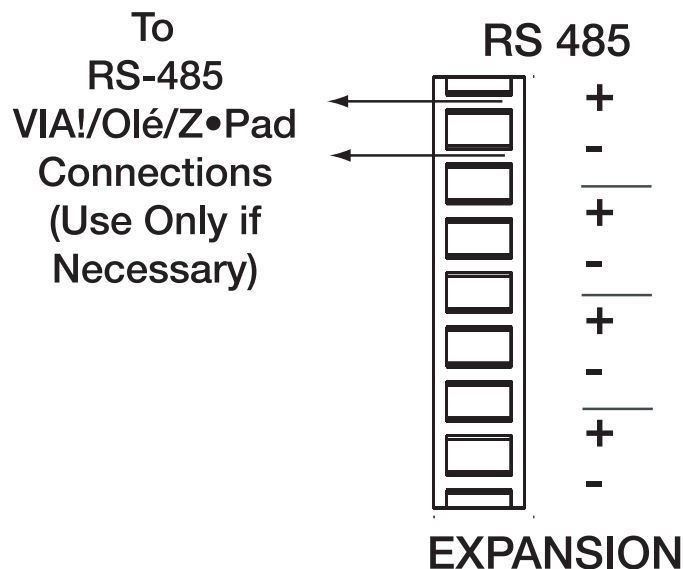

Figure 3-16: RS-485 Expansion Connections

Switches

There are three types of switches located on the rear of the SPP Precision panel: The INT 12V-EXT 16V switches (one per zone), the ZNET/VNET switch and the SS/SC4-NO SS/SC4 switch. These switches affect the function of the S86A Multi-Room Controller in various ways depending upon system configuration.

INT 12V-EXT 16V Switch

As previously described, the INT 12V-EXT 16V switch selects between internally generated voltage from the S86A Controller (+12 Volts DC) for use with Z•Pad Keypads and Olé Touchpads, or externally generated voltage from a power supply connected to the front of the SPP Precision Panel to be utilized by Olé Touchpads and VIA! Touch Panels. This selection applies only to the “Z#B 16V/12V OLÉ/ZPAD” punchdown location. Select INT 12V (UP) when 12VDC is required for keypads or touchpads. Selects EXT 16V (DOWN) when using an external 16VDC power supply for touch panels or touchpads.

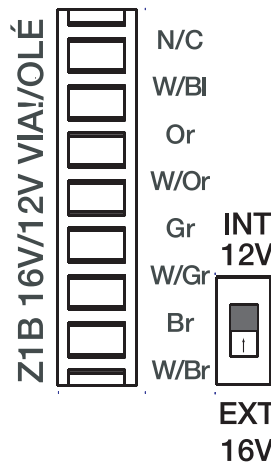

Figure 3-17: Internal/External Voltage Switch

ZNET/VNET Switch

The ZNET-VNET switch selects between systems based on ELAN’s ZNET (S66A and S128P Multi- Room Controllers) and VNET (S86A). This switch will always be in the VNET position when installing the SPP with the S86A Controller.

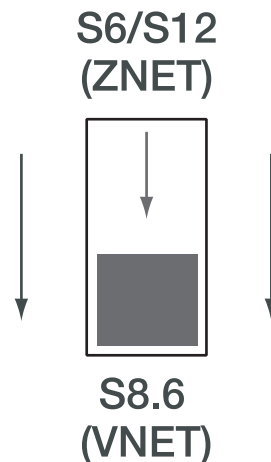

Figure 3-18: ZNET/VNET Switch

SS/SC4-NO SS/SC4 Switch

If the system contains an SS1 System Station or SC-4* Serial Controller, set this switch to the SS/SC4 position.
If the system does not contain an SS1 System Station or SC-4 Serial Controller, set the switch to the NO SS/SC4 position.

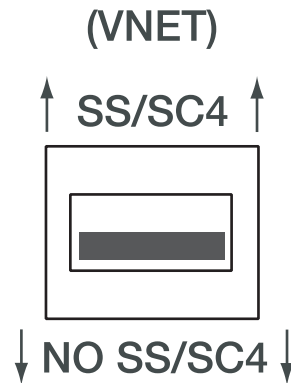

Figure 3-19: SS/SC4-No SS/SC4 Switch

**Note: The ELAN SC-4 is a discontinued product.*

Connections When Using an ELAN SPP System Precision Panel - Front

VIA!NET Connection

This RJ-45 connector is reserved for future use.

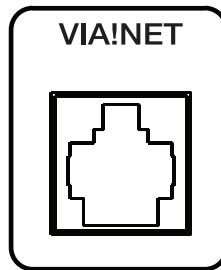

Figure 3-20: VIA!NET Connection (Future Use)

EXT IR Connections

The EXT IR connector is NOT used for S86A-based systems.

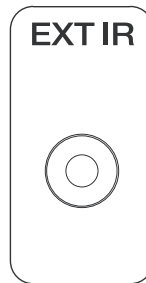

Figure 3-21: EXT IR Connection (Not Used)

Sense Input Connections

Information from ELAN™SENSE Sensors connected to the S86A's ELAN SENSE INPUTS is used to trigger events that have been programmed into VIA! Touch Panels. Typically, sensors will connect to the back of the SPP precision Panel, then 3.5mm stereo interconnect cables will be used between the Precision Panel's TO SENSE INPUTS jacks and the S86A Controller's ELAN SENSE INPUTS jacks. Utilize VIA!TOOLS or ELANTOOLS Setup Software to create IR or serial command strings for automated functions. See the VIA!TOOLS or ELANTOOLS Help file for additional information about programming Sense Inputs.

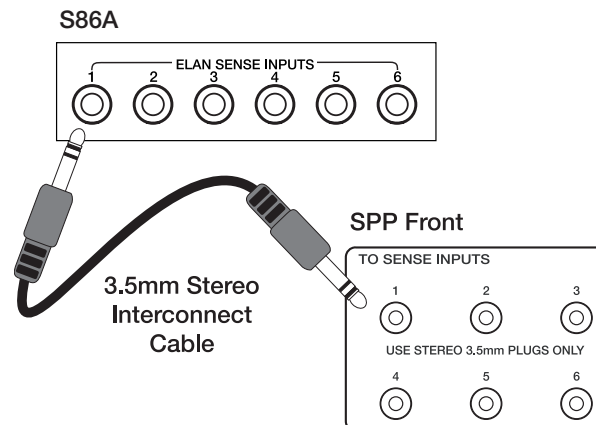

Figure 3-22: Sense Input Connections

SS/SC4 Connection

Use the SS/SC4* RJ-45 connector to integrate an ELAN SS1 System Station or SC-4 System Controller to the S86A Multi-Room Controller in order to facilitate integration of RS-232 controlled systems such as security, lighting or HVAC. Use an RJ-45 Interconnect Cable for this purpose.

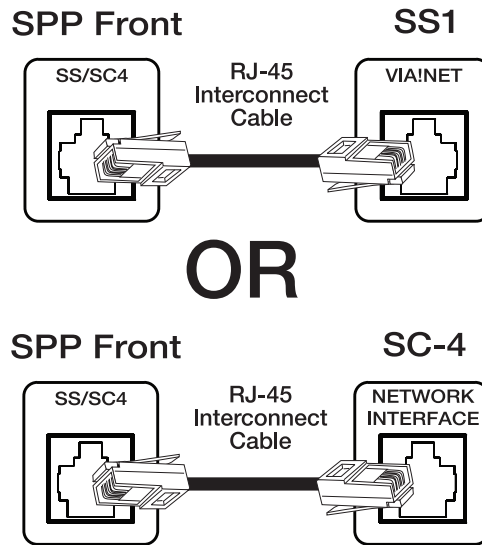

Figure 3-23: SS/SC4

**Note: The SC-4 is a discontinued product.*

ZONE 1-8 Connections

Connect a straight-through RJ-45 interconnect cable (1 or 2 meter Interconnect Cable) between the S86A's 1-6 Zone Inputs and the SPP Zone 1-8 RJ-45 jacks. This routes all keypads, touch panels, touchpads and IR receivers punched-down on the back of the SPP directly to the S86A. Zones 7-8 are not connected in S86A systems.

Note: In order to facilitate RS-485 communication, Zone 1 must ALWAYS be connected between the S86A Controller and the SPP Precision Panel.

SPP to S86A Zone Connections (Zone 1 shown)

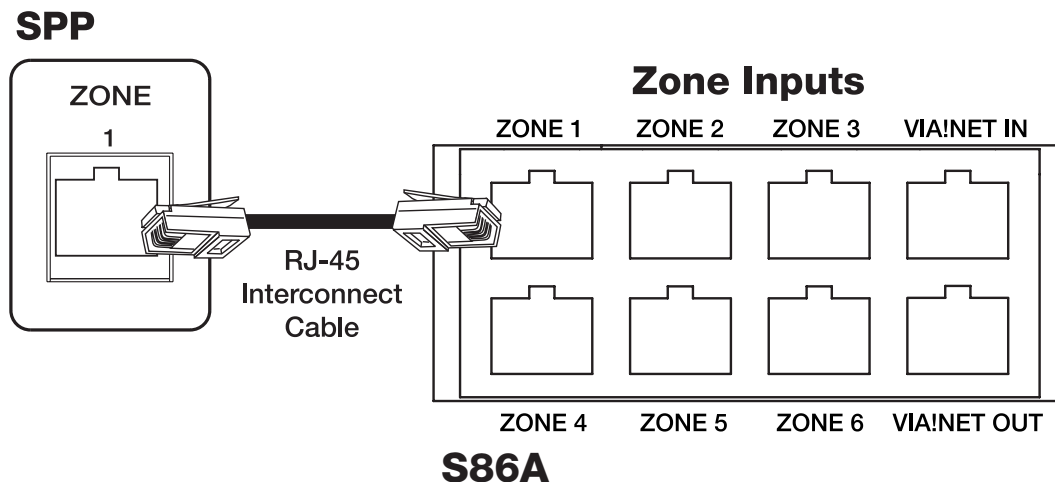

Figure 3-24: Zone Keypad Input Connections

Triggers Connections

There are 6 PROGRAMMABLE TRIGGER OUTPUTS on the S86A Controller. By default, these are zone-specific; each becomes active when its corresponding zone becomes active. Use these when zone-specific functions are desired; for example, use the PROGRAMMABLE TRIGGER OUTPUTS to mute/un-mute specific channels on an A12 or D12 amplifier. These outputs can be programmed in VIA!TOOLS or ELANTOOLS Setup Software to become active with IR or serial commands to create automated events. Use 3.5mm mono interconnect cables to connect the S86A Controller's PROGRAMMABLE TRIGGER OUTPUTS to the SPP Precision Panel's TRIGGERS connections. The TRIGGERS 7-8 on the SPP are unused in S86A systems.

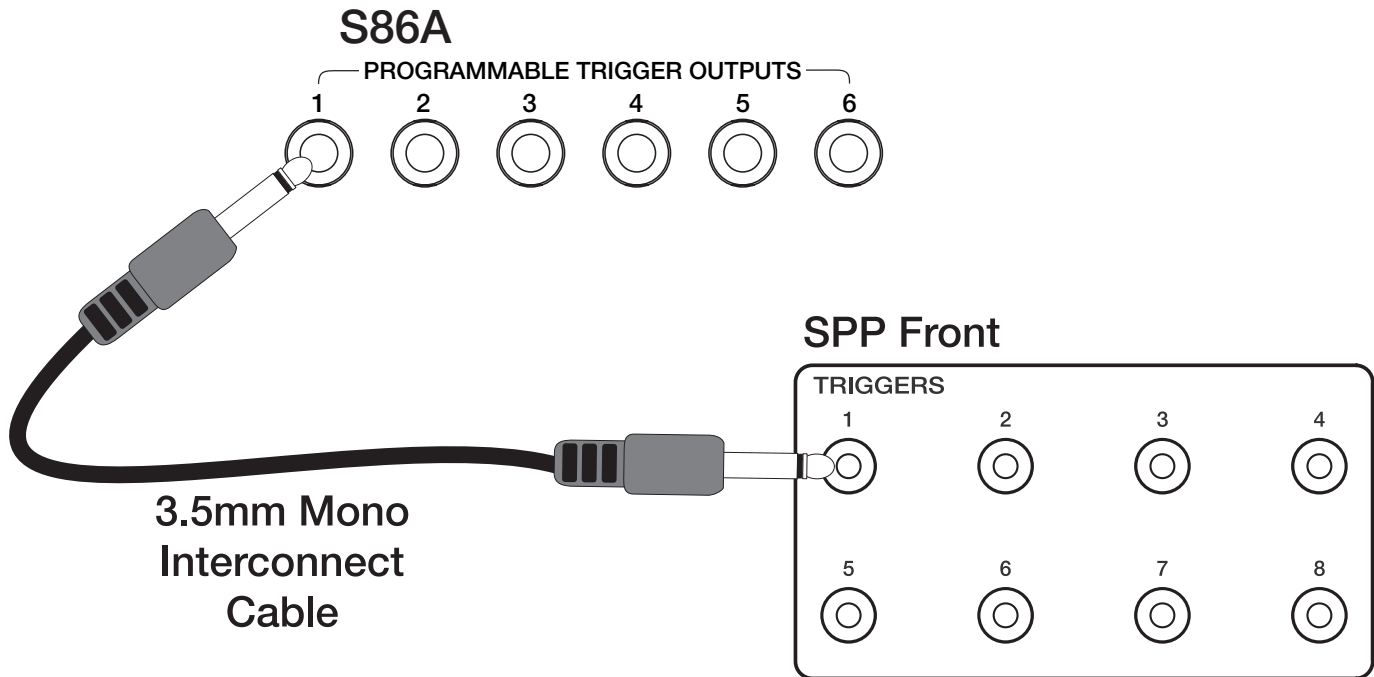

Figure 3-25: Triggers Connection

Power Connections

It is possible to connect and power up to ten VIA! Touch Panels using the SPP and a 16VDC power supply. Use punchdown locations “A” and “B” and place the INT V-EXT V switch in the EXT position for each zone that utilizes 16VDC from the connected power supply. Use an ELAN PWR1 16VDC/1A power supply for one VIA! Touch Panels. Use an ELAN PWR4 16VDC/ 4A power supply for up to four VIA! Touch Panels. Use an ELAN PWR10 16VDC/10A power supply for five-to-ten VIA! Touch Panels. It is also possible to connect up to 66 Olé Touchpads using the same 16VDC power supplies. A PVIA1 will power up to 6 Olé touchpads, a PVIA4 can power up to 26 Olé touchpads and a PVIA10 Power Supply can support 66 Olé touchpads. A combination of VIA! Touch panels and Olé Touchpads can be accomodated. Please consult the chart below for maximum current draw of each device.

Note: Only one power supply should be connected to the SPP Precision Panel at any time!

16V/4A Power Supply Connections

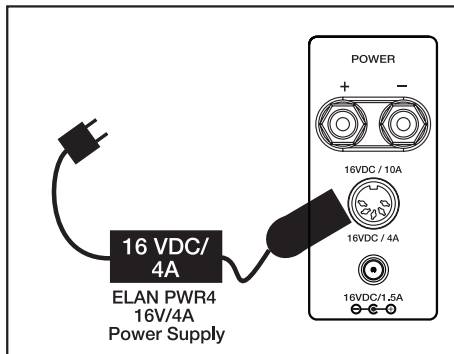

16V/10A Power Supply Connections

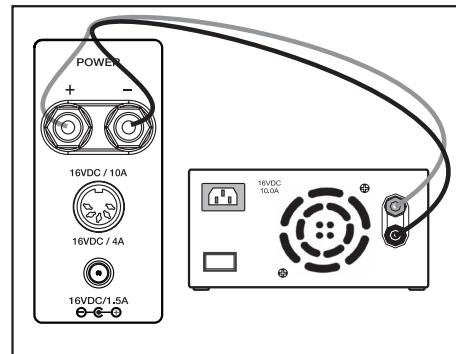

16V/1.5A Power Supply Connections

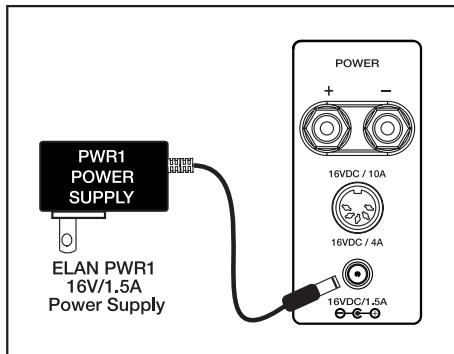

IMPORTANT NOTE
Olé Touchpads
and VIA! Touch Panels

Use the correct power supply connected to the front of the SPP for the number of Olé Touchpads and VIA! Touch Panels in the system.

Olé = 150mA
 VIA! = 1A

PWR1 = 1A
 PWR4 = 4A
 PWR10 = 10A

Figure 3-26: SPP Power Connections

S86A Connections When NOT Using a System Precision Panel

Sense Input Connections

Information from ELAN™SENSE Sensors connected to the S86A's ELAN SENSE INPUTS is used to trigger events that have been programmed into VIA! Touch Panels. To connect ELANSENSE Sensors directly to the S86A, simply plug the 3.5 mm stereo plug of the Sensor into the desired ELAN SENSE INPUT. If long runs are required, the 3.5 mm stereo interconnect cable must be cut off and the cable extended using Cat-5. Utilize VIA!TOOLS or ELANTOOLS Setup Software to create IR or serial command strings for automated functions. See the VIA!TOOLS or ELANTOOLS Help file for additional information about programming Sense Inputs.

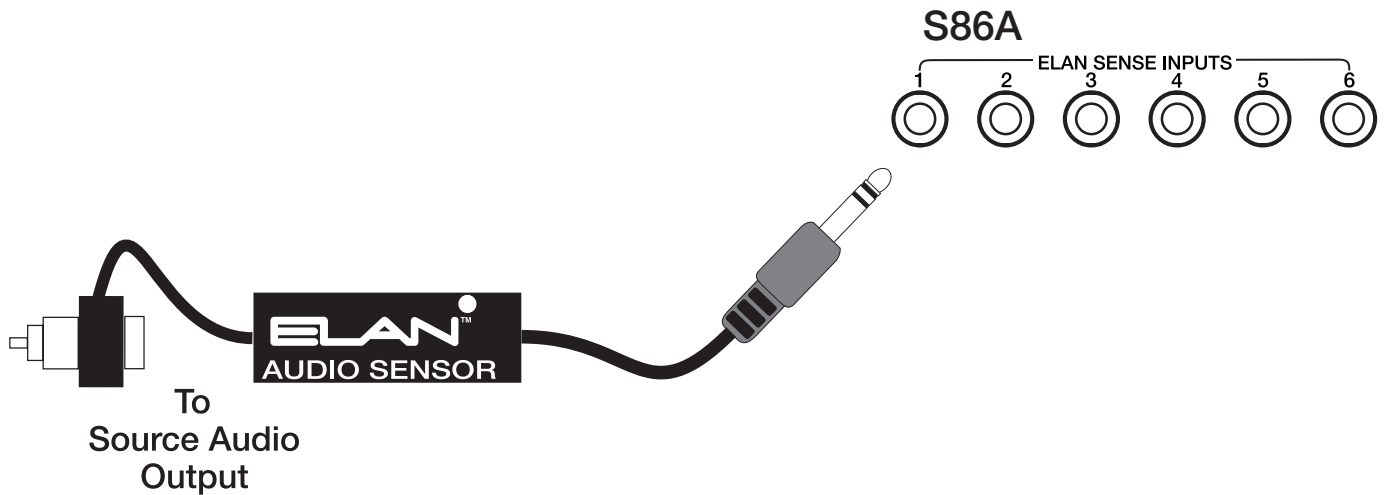
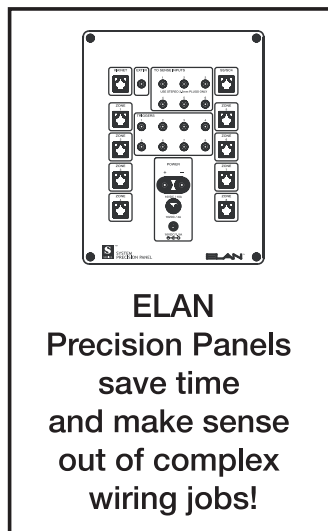

Figure 3-27: Sense Trigger Input Connections



VIA! Touch Panel Connections

If not using the SPP Precision Panel, it is necessary to use a PVIA1, PVIA4, or PVIA10 Wall Plate when connecting VIA! Touch Panels to the S86A. VIA! Touch Panels require the 16V power supplies that are included with each PVIA wall plate (PVIA1, PVIA4, and PVIA10).

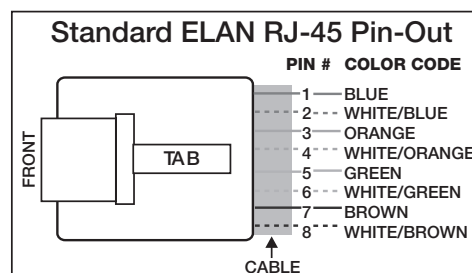
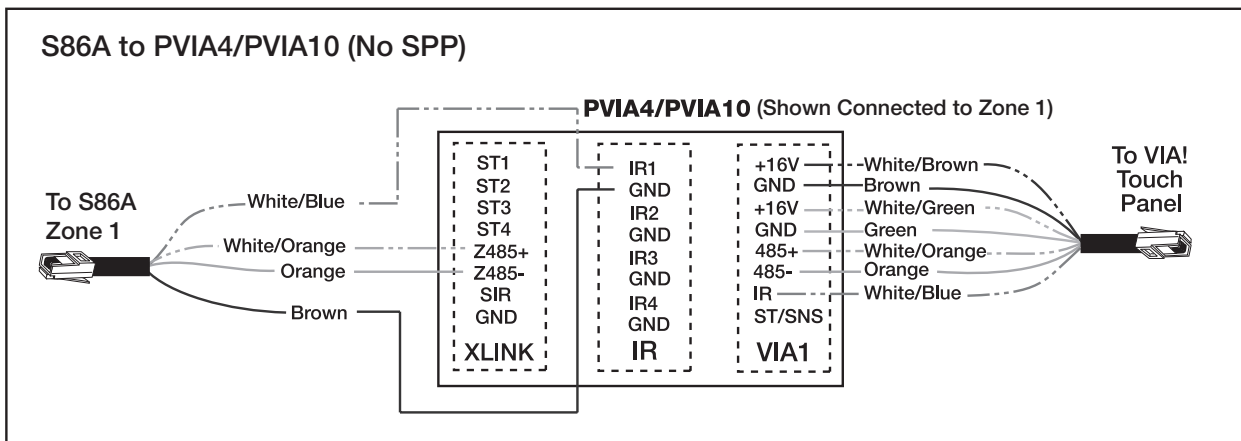
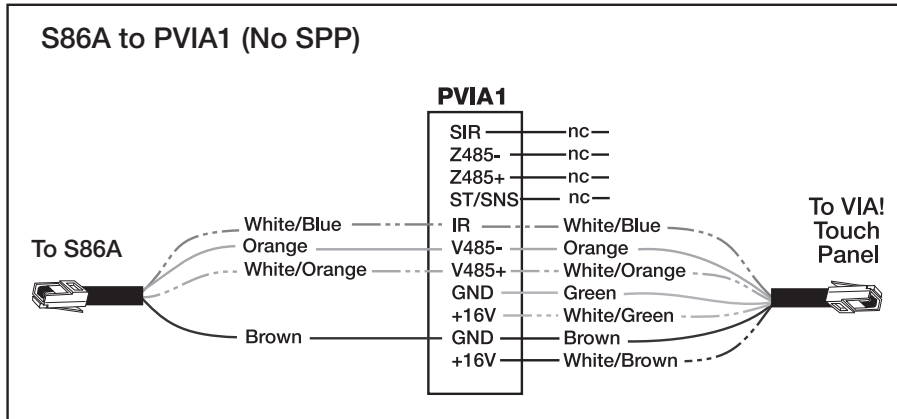

Figure 3-28: VIA! Touch Panel Connections (No SPP)

Olé Touchpad Connections

ELAN Olé Touchpads require IR, RS-485+, RS-485-, 12 Volts DC, and Ground to function. Make these connections as shown below. Multiple keypads in the same zone require parallel connections. For simplicity, all eight wires can be connected straight through.

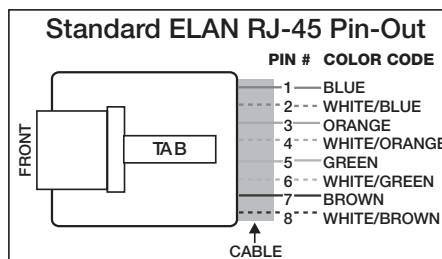
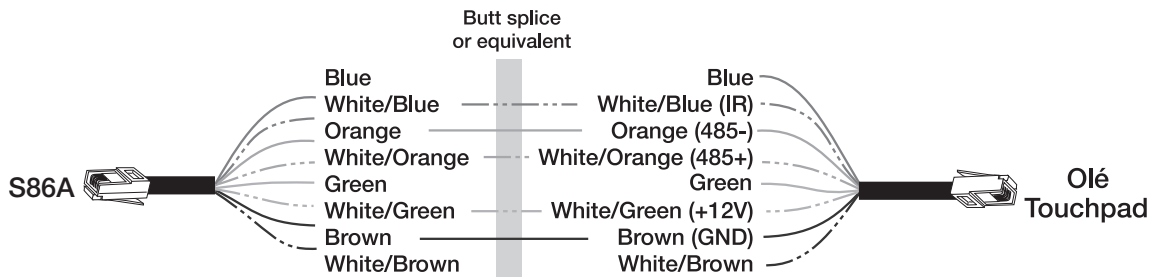

Figure 3-29: Olé Touchpad Connections (No SPP)

Keypad Connections

ELAN keypads require IR, 12 Volts DC, and Ground to function. Make these connections as shown below. Multiple keypads in the same zone require parallel connections.

Note: ELAN Z•PAD keypads will NOT receive status feedback when connected to the S86A.

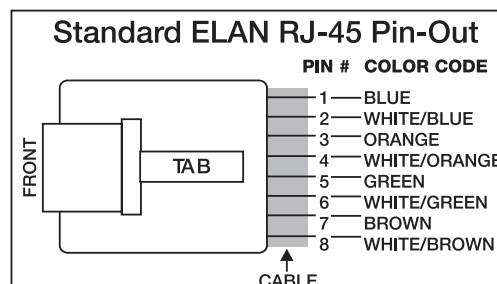
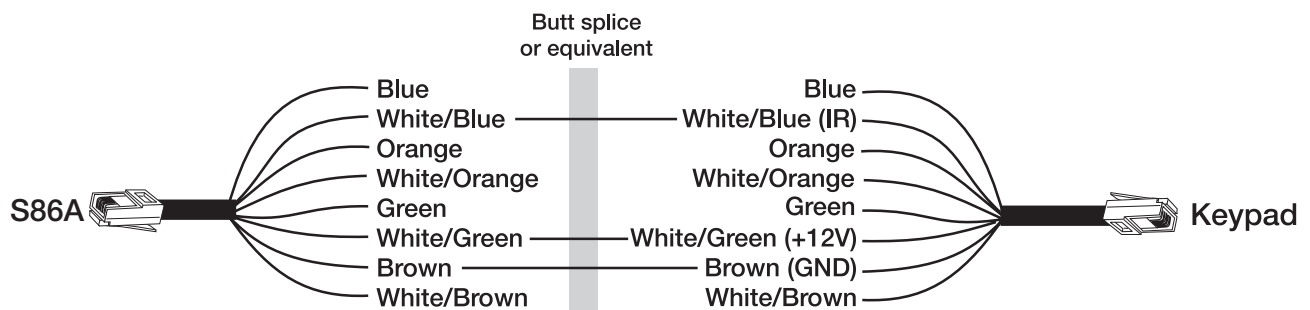

Figure 3-30: Keypad Connections (No SPP)

Programmable Trigger Output Connections

There are 6 zone-specific Trigger outputs on the S86A Controller. Use these when zone-specific functions are desired; for example, use the PROGRAMMABLE TRIGGER OUTPUTS to mute/un-mute specific channels on an A12 or D12 amplifier. Use 3.5mm mono interconnect cables to connect the S86A Controller's PROGRAMMABLE TRIGGER OUTPUTS to the device that needs to be turned on.

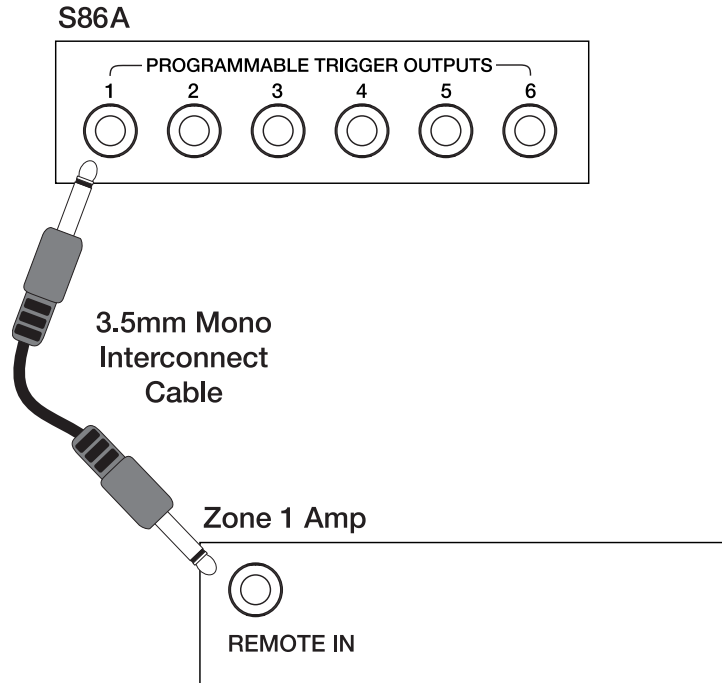

Figure 3-31: Programmable Trigger Output Connections

SYSTEM TRIGGER OUT Connections

Use the SYSTEM TRIGGER OUT to connect devices that need to be turned on when any zone of the system is turned on. The SYSTEM TRIGGER OUT sends a signal when any zone of the S86A controller is turned on. Using VIA!TOOLS or ELANTOOLS Setup Software, the SYSTEM TRIGGER OUT can be programmed to become active based on IR or Serial commands. Use 3.5mm mono interconnect cables to connect the S86A Controller's SYSTEM TRIGGER OUT to the device that needs to be turned on.

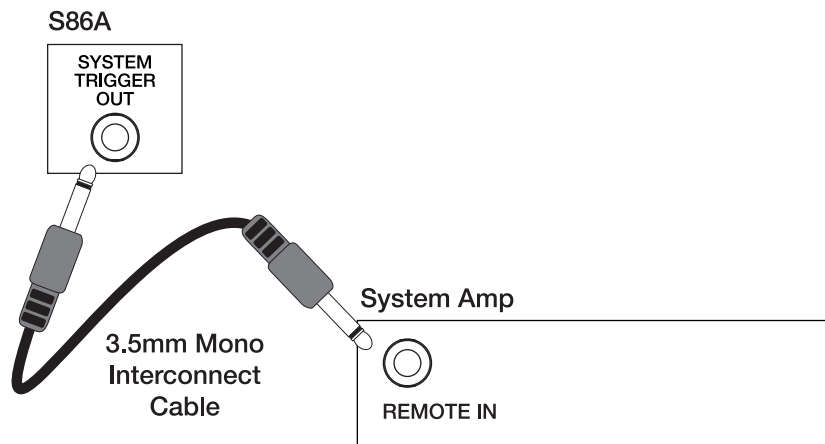

Figure 3-32: System Trigger Out

Additional S86A Connections (With or Without SPP Precision Panel)

The information below describes all connections that are made directly to the S86A regardless of the use of the SPP Precision Panel.

SOURCE IR OUTPUT Connections

The S86A features 8 source-specific IR emitter outputs. Each of these outputs is active only when the assigned source is selected. This makes it possible to use identical source components and still have the capability of separate control. For ELAN multi-output sources such as VIA!dj or DTNR, VIA!TOOLS or ELANTOOLS setup software will automatically route IR out of each IR port that the source is assigned to. The example below shows a VIA!dj that is connected to Audio Inputs 1, 2, 3, and 4. Any of IR Emitter Outputs 1 through 4 can be used to control the VIA!dj. To connect non-ELAN multi-output sources, see IR 'ALL' Output Port Connections below.

When connecting multiple S86A chassis, it is only necessary to connect IR sources to chassis #1. SOURCE IR EXPANSION PORTS provide a link between chassis to facilitate this function.

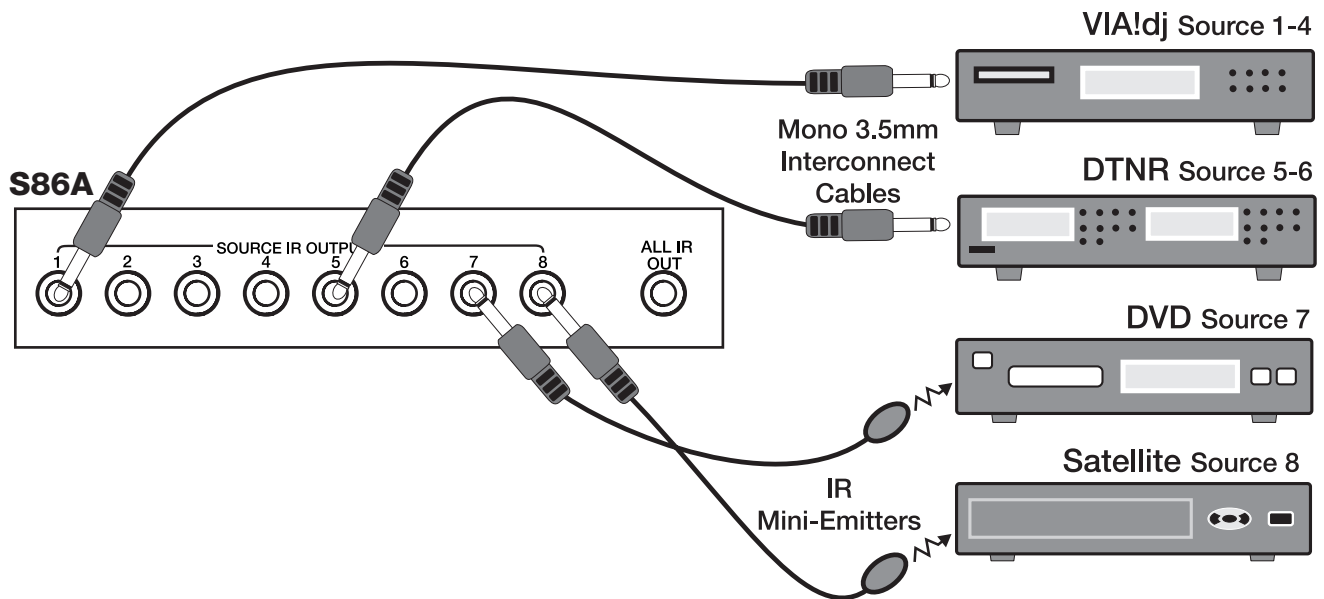

Figure 3-33: Source IR Emitter Output Connections

ALL IR OUT Port Connections

An ALL IR OUT port is provided for controlling additional components such as Televisions or A/V Receivers that may require control regardless of the source currently selected. The ALL IR OUT ports are active from chassis to chassis in multiple chassis configurations and are always active: any IR signal sent into any S86A Chassis comes out the ALL IR OUT port of each chassis, as shown below. The ALL IR OUT port is also useful when controlling several non-identical sources. For really large installations, an ALL IR OUT port can be routed to an IR Distribution Block (such as ELAN's IRD4) and sent to several sources.

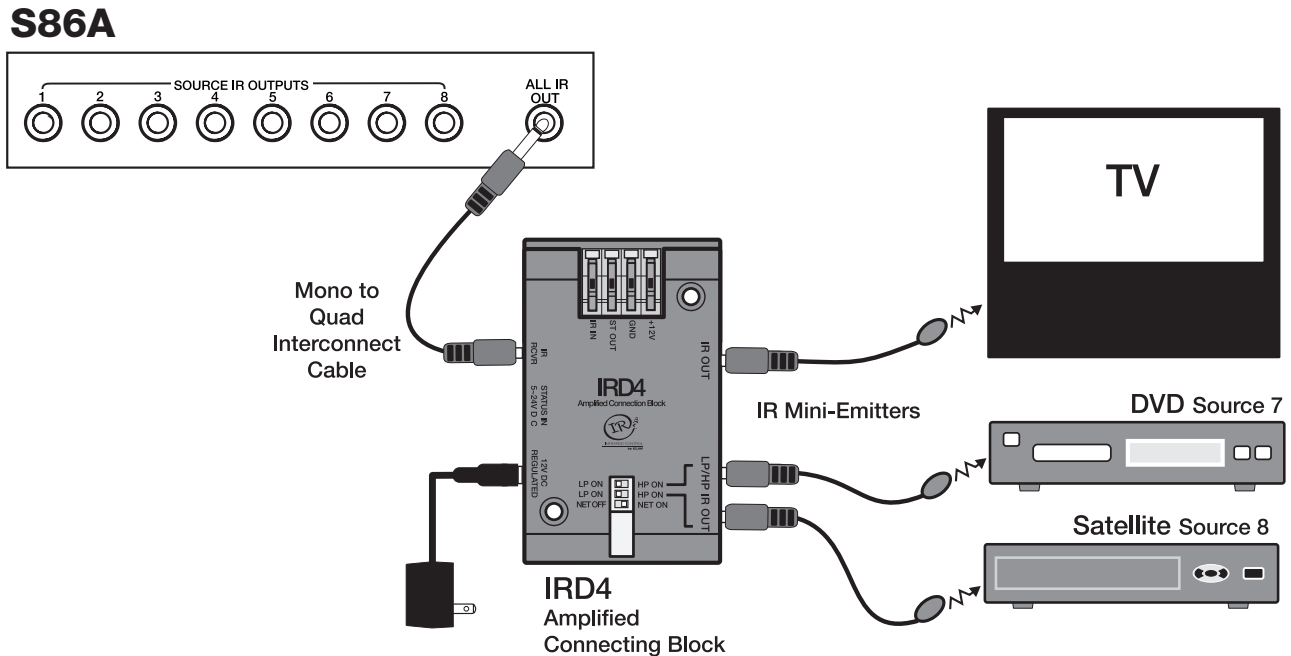

Figure 3-34: All IR OUT Port Connections

Audio/Video Connections

There are eight Audio SOURCE INPUTs and eight Audio LOOP OUTPUTS on the S86A. Each system source will be connected to a specific SOURCE INPUT, allowing audio distribution to any zone of the S86A. Each SOURCE INPUT corresponds to the same-numbered SOURCE IR port.

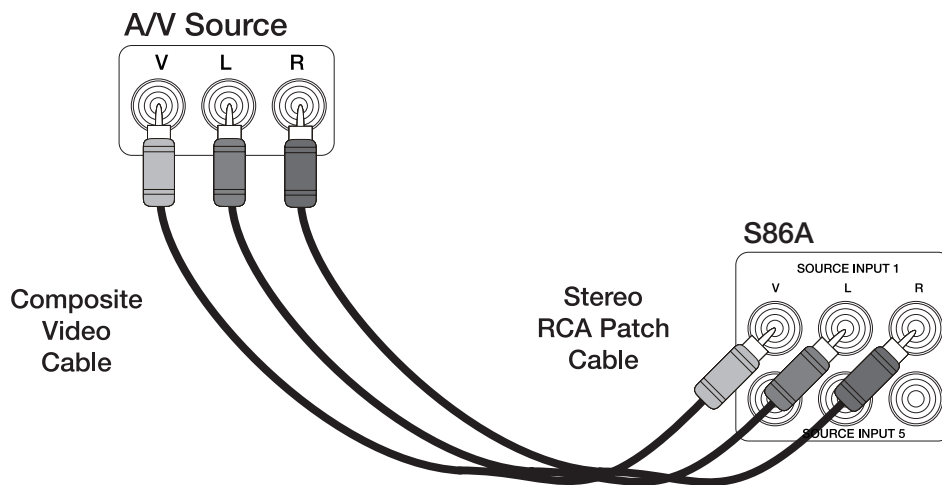

Figure 3-35: Audio/Video Connections

Loop Output Connections

Ideal for sharing sources with Home Theaters, the Loop Outputs pass line-level audio and composite video directly out of the corresponding Source Input. The audio and video are buffered, therefore no signal loss will occur. Use RCA audio/video cables to connect a Loop Output to additional S86A chassis or a Home Theater receiver.

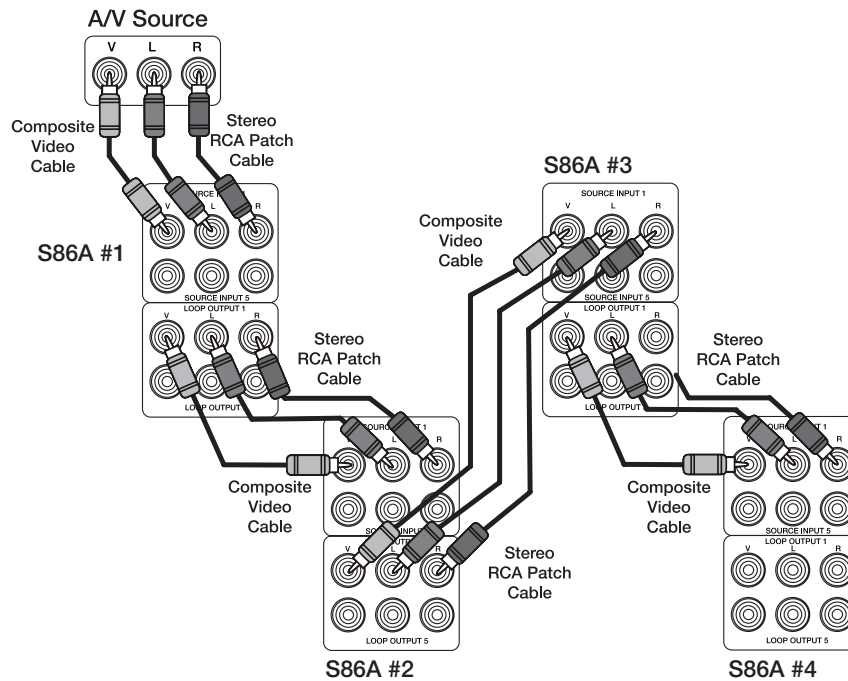

Figure 3-36: Loop Output Connections-Multiple Chassis

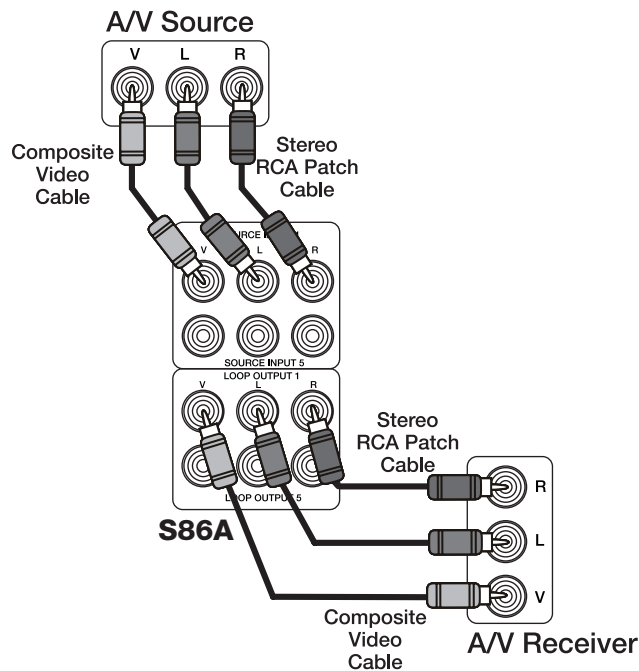

Figure 3-37: Loop Output Connections-A/V Receiver

Advanced Video Switching-Composite Video

By default, each ZONE PREAMP OUTPUT automatically switches audio and video signals simultaneously. It is possible to have multiple outputs going to the same zone. Use VIA!TOOLS or ELANTOOLS setup software to configure these outputs. Make connections as shown in *Figure 3-38*.

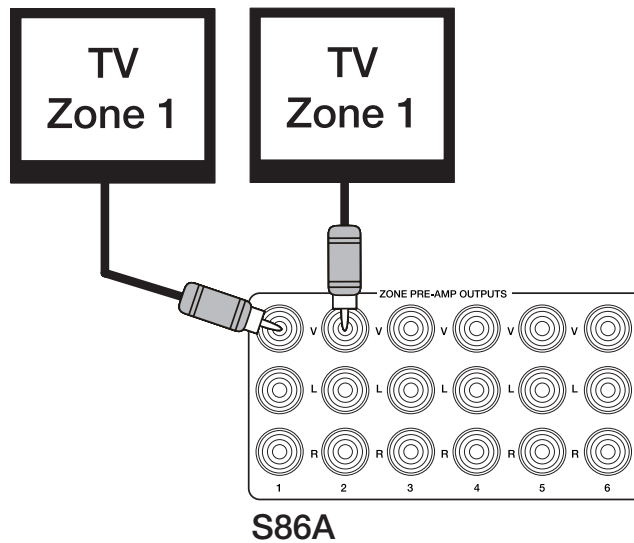

Figure 3-38: Advanced Video Switching-Composite Video Connections

V8 Video Controller

In advanced systems that require more than six composite video outputs (per chassis) to some or all of the S86A's zones, use an ELAN V8 Video Controller to switch up to eight sources to up to eight zones (or use up to three V8s to switch up to eight sources to up to twenty-four zones). Connect a composite video cable from each source's Video Loop Output to an input of the V8. Connect each output of the V8 to a TV, VIA! Touch Panel, or monitor located in a zone, (see *Figure 3-39*). Use the ALL IR port on the S86A to control the V8 (see *All IR Out Port Connections*), or control it serially from VIA! Touch Panels or Olé Touchpads using a SS1 System Station connected to the ELAN RS-232 Port (see *RS-232 Connections*).

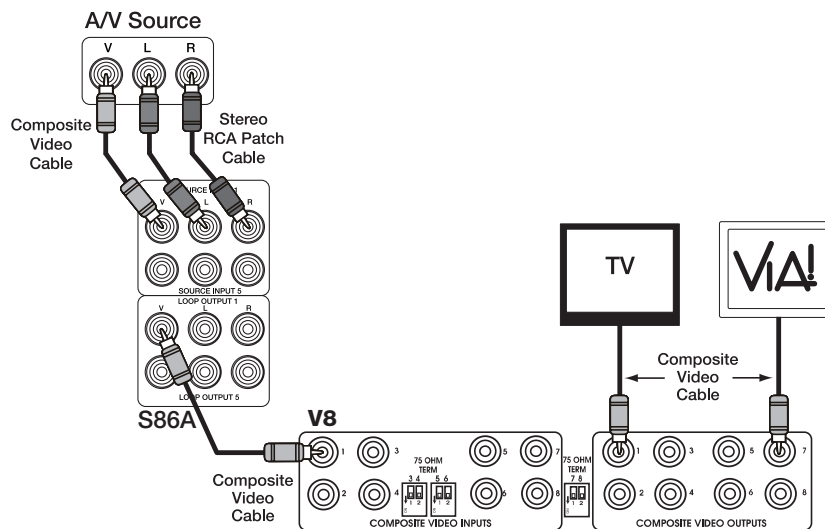

Figure 3-39: V8 Video Controller

VIA!QUAD 4-Channel Video Processor

The VIA!QUAD allows four video signals to be displayed simultaneously, sequentially, or independently. By connecting the output of the VIA!QUAD to a single video input of the S86A, up to four cameras can be connected while only using up one of the S86A's Source Inputs. The video sources/cameras that are connected in this way can then be switched and displayed on any TV, VIA! Touch Panel, or monitor that is connected to the system.

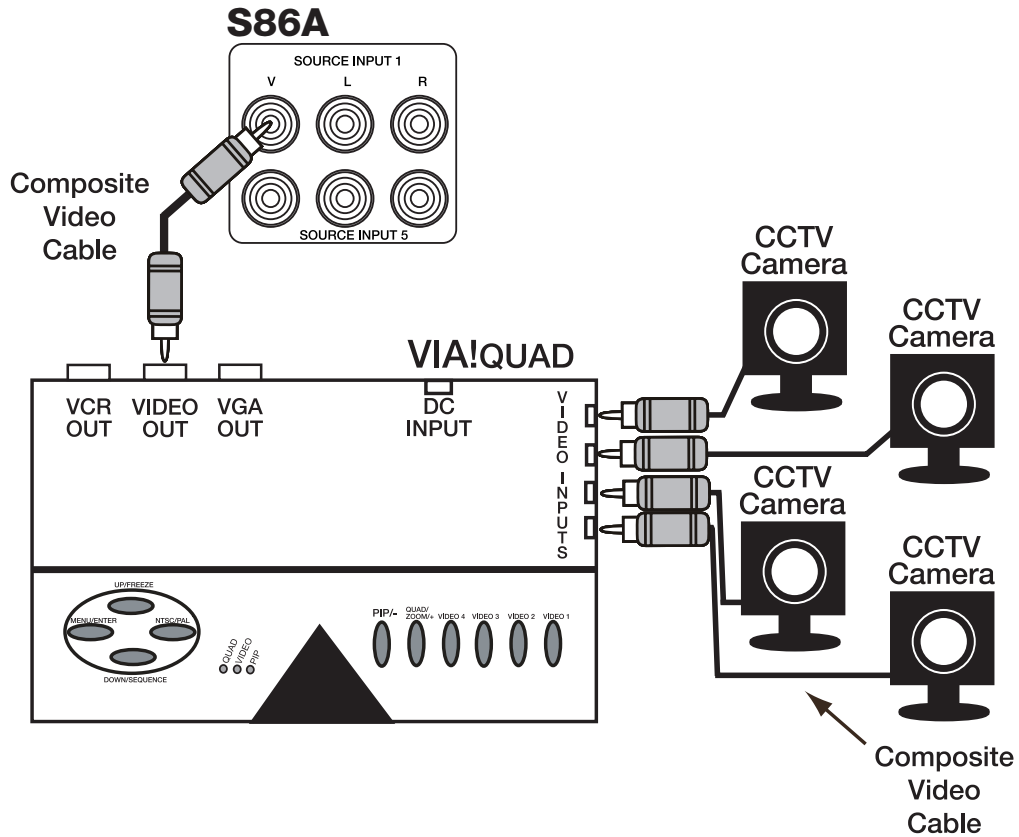

Figure 3-40: VIA!QUAD 4-Channel Video Processor

Advanced Video Switching-Component Video

V85 Component Video Controller

Use an ELAN V85 (or multiple V85s) to switch component video. Up to 8 sources can be switched to up to 32 locations using multiple V85s. Connect RCA audio patch cables from a source to the S86A's Source Audio Inputs. Connect component video cables from the source to the V85's Component Video Inputs. Control using IR (see *All IR Out Port Connections*) or RS-232 (see *RS-232 Connections*) is possible.

Note: The S86A is used to switch composite video only in this application. Use ELAN's V85 Component Video Controller to switch component video.

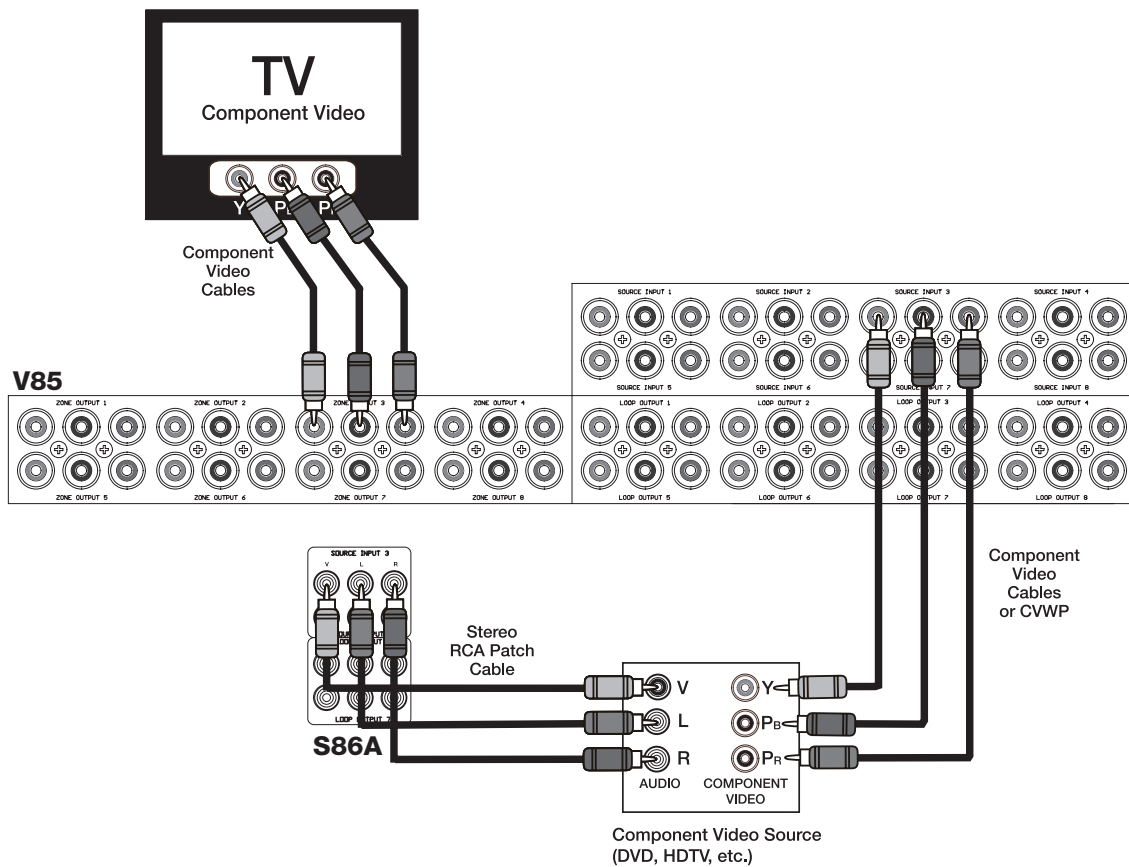

Figure 3-41: Advanced Video Switching Connections

Note: The V85 also has an optional CAT-5 Zone Output that is compatible with CVWP Receive Wallplates.

Zone Preamp Outputs-Audio

Each zone of the S86A has a corresponding Zone Preamp Output for both audio and video. The audio outputs are used to send signals to auxiliary amplifiers-typically for sub-zone applications. Each zone's audio is sent out of both the Speaker Outputs and the Zone Preamp Outputs simultaneously. Use the FIXED/VARIABLE DIP switch for each zone to correctly configure this output. FIXED zones are set to full volume at all times (volume is controlled using a volume control located in the zone). FIXED subzones each typically have their own volume control in order to have independent volume Up/Down and will always share the source that the rest of the zone is playing. VARIABLE zones ramp volume Up and Down using IR or serial commands sent from a touch panel, touchpad, keypad, or hand-held remote. VARIABLE sub-zones share both source selection and volume Up/Down functionality (all speakers ramp volume Up/Down simultaneously). Default DIP switch settings are VARIABLE (all DOWN).

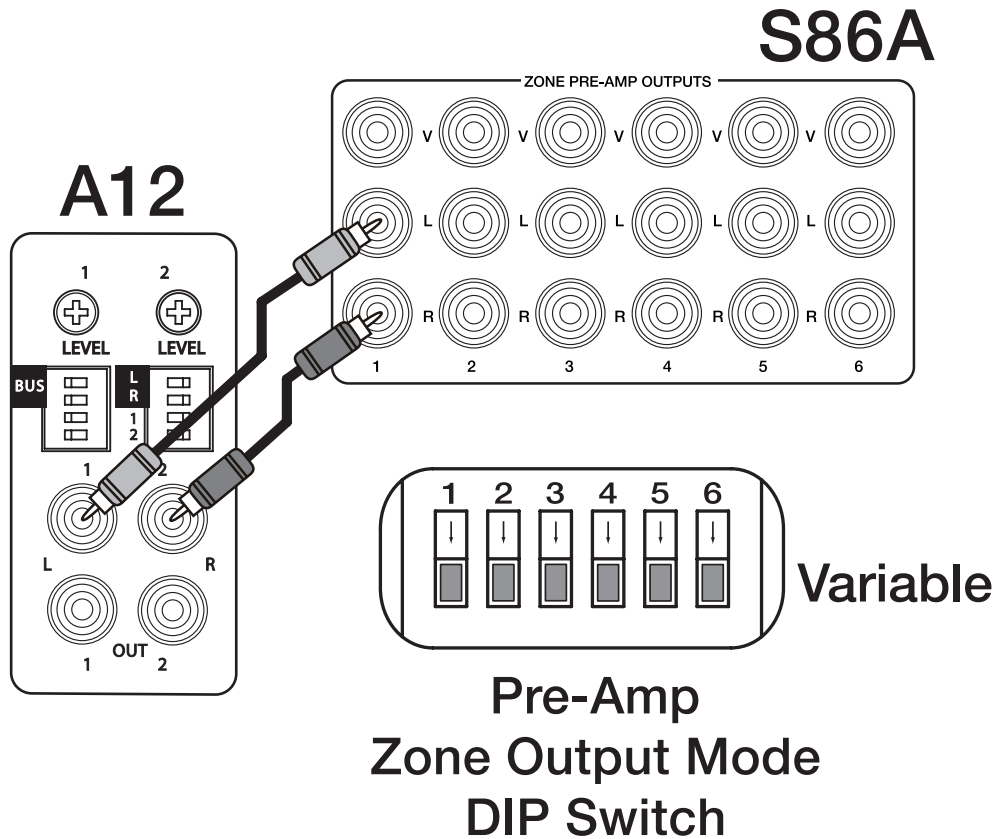

Figure 3-42: Zone Preamp Outputs-Audio

Zone Preamp Outputs-Video

The video Zone Preamp Outputs are used to send signals to TVs, VIA! Touch Panels, or monitors located in the various zones of the house. By default, each zone has a single video output. It is possible to have multiple outputs going to the same zone. Use VIA!TOOLS or ELANTOOLS setup software to configure these outputs (see *Advanced Video Switching-Composite Video*). If more complex video switching is needed for a particular system, ELAN recommends the use of a V8 Video Controller to switch up to eight sources to up to eight zones (or use up to three V8s to switch up to eight sources to up to twenty-four zones). See *Loop Output Connections- Advanced Video Switching* for details.

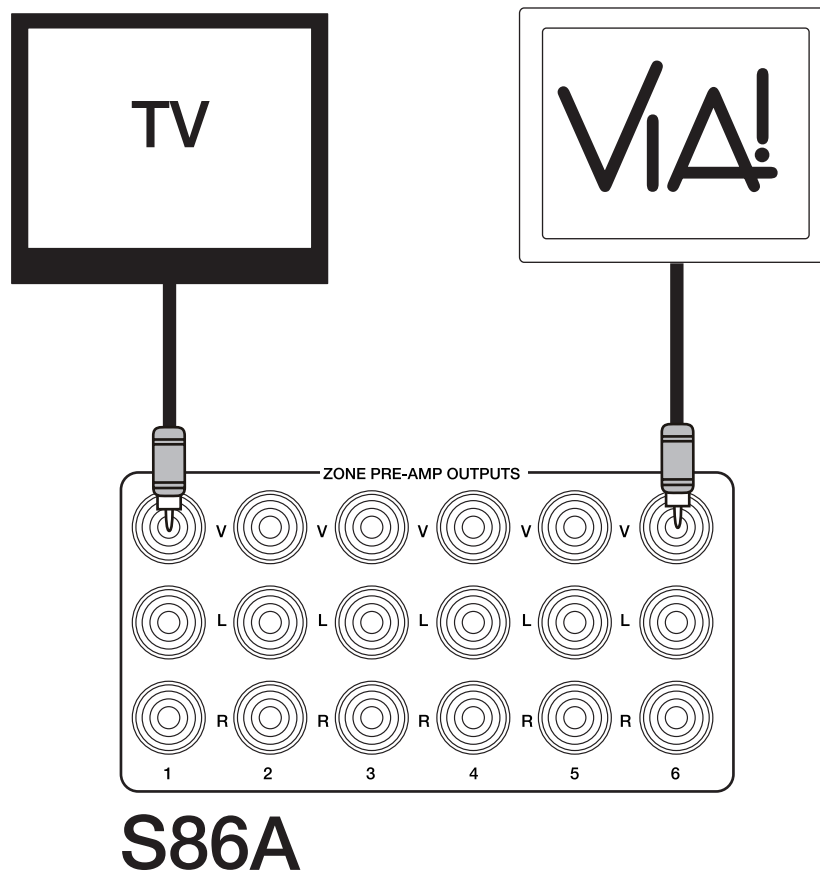

Figure 3-43: Zone Preamp Outputs-Video

Speaker Outputs

The Quick Lock connectors on the S86A can accept 28 to 16 AWG speaker wires. These wires can be directly connected to speakers located throughout the home, or, for a professional appearance, can be connected to ELAN's PSP12 Speaker Precision Panel using bare leads or banana plugs.

Note: *Speaker Outputs are always VARIABLE and are unaffected by the ZONE Preamp Output DIP Switches.*

Note: *Because the Speaker Outputs are Variable, it is NOT RECOMMENDED to use Volume Controls with the S86A's builtin amplifier. Unanticipated volume functionality may result. Subzones requiring the use of Volume Controls should utilize an external amplifier connected to the S86A's ZONE PREAMP OUTPUTS. The ZONE PREAMP OUTPUTS should be set to FIXED.*

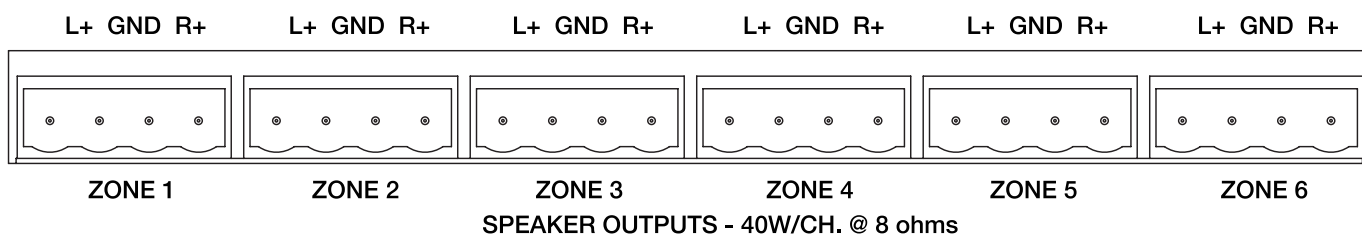

Figure 3-44: Speaker Output Connections

To Connect Speaker leads:

1. Open each Quick Lock connector.
2. Strip approximately 1/2" of the insulation from each speaker lead.
3. Twist the speaker wires to remove any loose strands.
4. Insert the leads into the connectors.
5. Close the connectors. Tug slightly on the speaker lead to ensure connectivity.

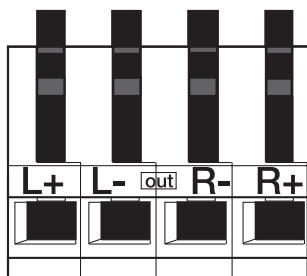

Figure 3-45: Quick Lock Connector

Important Notes:



- Use 28-16 AWG Stranded Copper Speaker Wire
- Amplifier is Rated at 8 Ohms.
Do Not Configure Impedance Below 8 Ohms.
- The built-in amplifier is NOT bridgeable. Do NOT attempt to bridge or combine channels.
- Volume Controls Are NOT Recommended.

ELAN RS-232 Ports

SC-4* RS-232 System Controller

When controlling the S86A with ELAN's SC-4 System Controller, use the 6-Pin DIN-to-9-Pin serial cable and the male-to-male DB9 gender-changer that is included with the SC4. Plug the 6-Pin DIN (round) connector into the SC-4's ELAN RS-232 OUT port. Using the gender-changer, plug the other end of the serial cable into the ELAN RS-232 IN port on the S86A. The SC-4 will always be connected to Chassis #1 in a multi-chassis system.

**Note: SC-4 is a discontinued product*

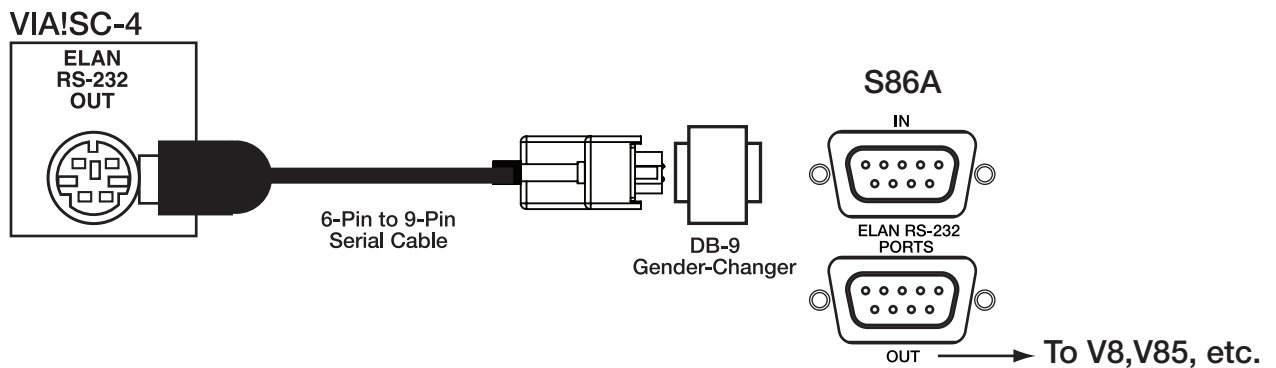

Figure 3-46: SC-4 Connections

SS1 System Station

When controlling the S86A with ELAN's SS1 System Station, use the DB-9 to DB-9 serial cable that is included with the SS1. Connect the cable from the SS1's ELAN RS-232 port to the S86A's ELAN RS-232 IN port. The SS1 will always be connected to Chassis #1 in a multi-chassis system.

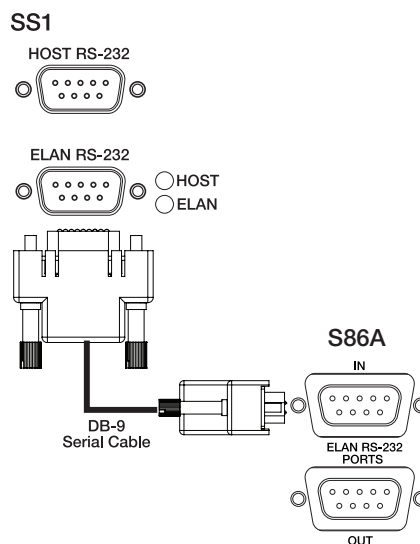

Figure 3-47: SS1 Connections

C2 Communications Controller Connections

ELAN's C2 Communications Controller provides whole-house paging when used with the S86A. The S86A's MOH OUT port provides Music On Hold to telephones connected to the C2. The audio from Source 1 of the S86A is routed out of the MOH OUT port and into the C2 as shown in Figure 3-48. The C2 sends a Trigger signal when a page or Door Chime is initiated that causes the S86A to mute any audio that is playing and pass the Page or Door Chime signals into speakers within the S86A's zones at a preset level. Use a mono 3.5mm interconnect cable to connect the SUM TRIGGER OUT from the C2 Communications Controller to the S86A's PAGE TRIGGER IN port. Use a stereo RCA patch cable between the C2's PG/DB OUT connector and the S86A's PG IN connector as well as between the C2's MOH IN connector and the S86A's MOH OUT port.

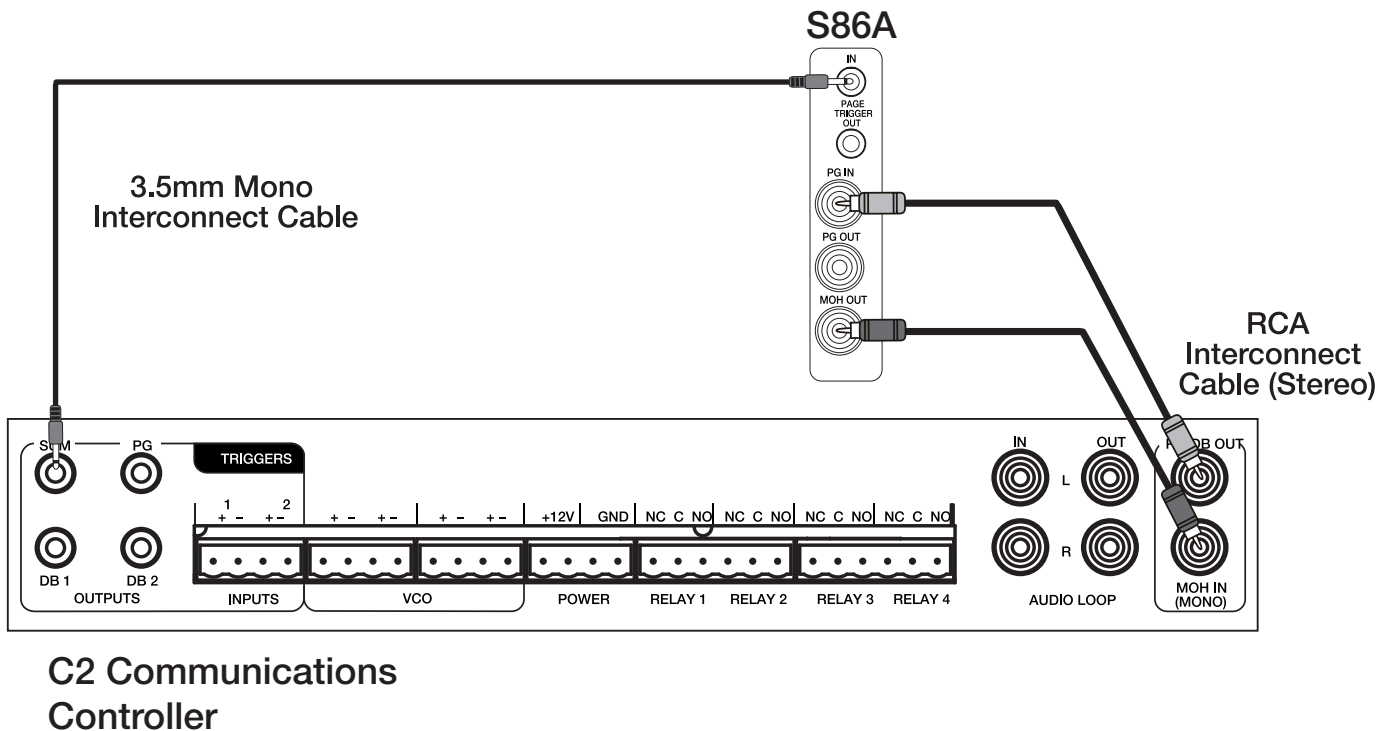

Figure 3-48: PG/DB Out and MOH Connections

VSE2 Electronic Volume Control

Connections

VSE2 Electronic Volume controls are excellent for use in sub-zones. Use an external amplifier connected to the appropriate ZONE PREAMP OUTPUTS. Make sure to set the dip switch for the specific zone to FIXED. If not using an SPP Precision Panel, interconnects will need to be made between the Electronic Volume Control, the S86A, the C2 Communications Controller, and the amplifier used for sub-zones. This application will provide IR source control, subzone volume control and Override in both the zone and sub-zone. These connections include IR, 12VDC, Ground, and Override, as shown in *Figure 3-50*.

Note: Because the S86A's Speaker Outputs are Variable, it is **NOT RECOMMENDED** to use Volume Controls with the S86A's builtin amplifier. Unanticipated volume functionality may result. Subzones requiring the use of Volume Controls should utilize an external amplifier connected to the S86A's ZONE PREAMP OUTPUTS. The ZONE PREAMP OUTPUTS should be set to **FIXED**. (see *Figure 3-49*)

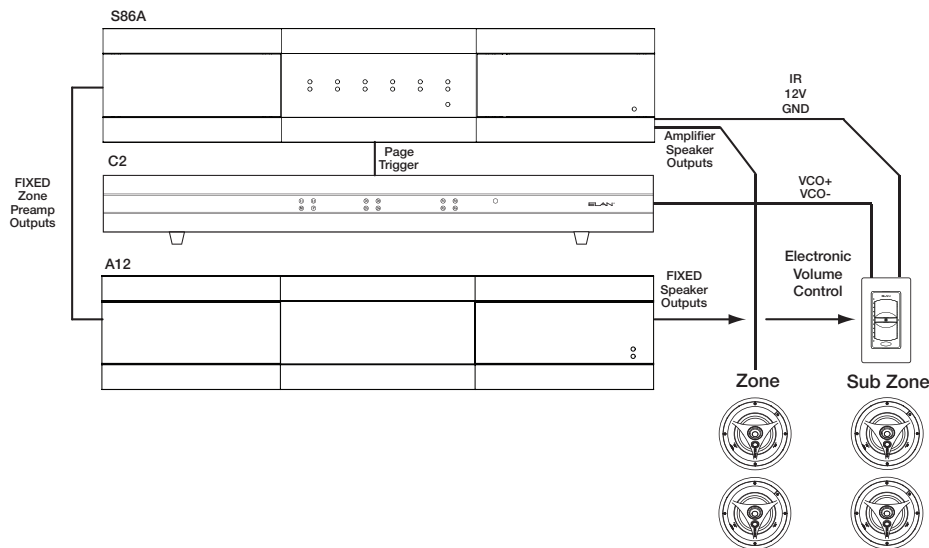

Figure 3-49: Sub-Zone Configuration w/ Volume Control

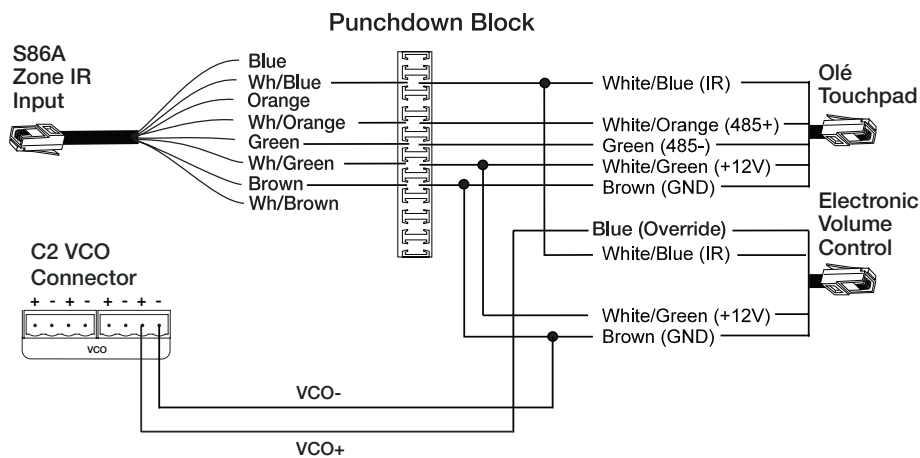

Figure 3-50: VSE2 Volume Control Connections

Multi-Chassis Connections

It is necessary to purchase and use ELAN's S12XK Expansion Kit when installing more than one S86A chassis. One S12XK Kit must be used for each additional chassis. All required cables are included in the S12XK Kit. **Figure 3-51** through **3-55** show all connections necessary when installing multiple S86A chassis. See **Figure 4-3** for required Unit ID DIP switch settings.

Relevant connections are:

- Audio and Video LOOP OUTPUTS/SOURCE INPUTS
- SOURCE IR EXPANSION PORTS
- ELAN RS-232 PORTS (if controlling the S86A with RS-232)
- C2 Connections (if using a C2 Communications Controller)

Loop Outputs/Source Inputs

Use RCA Audio and Video cables to connect a source to S86A #1. Use additional cables to add additional chassis, as shown in **Figure 3-51**. Route cables from each source's LOOP OUTPUT of S86A #1 to the corresponding SOURCE INPUT of S86A #2. Follow this pattern through S86A #4, if applicable.

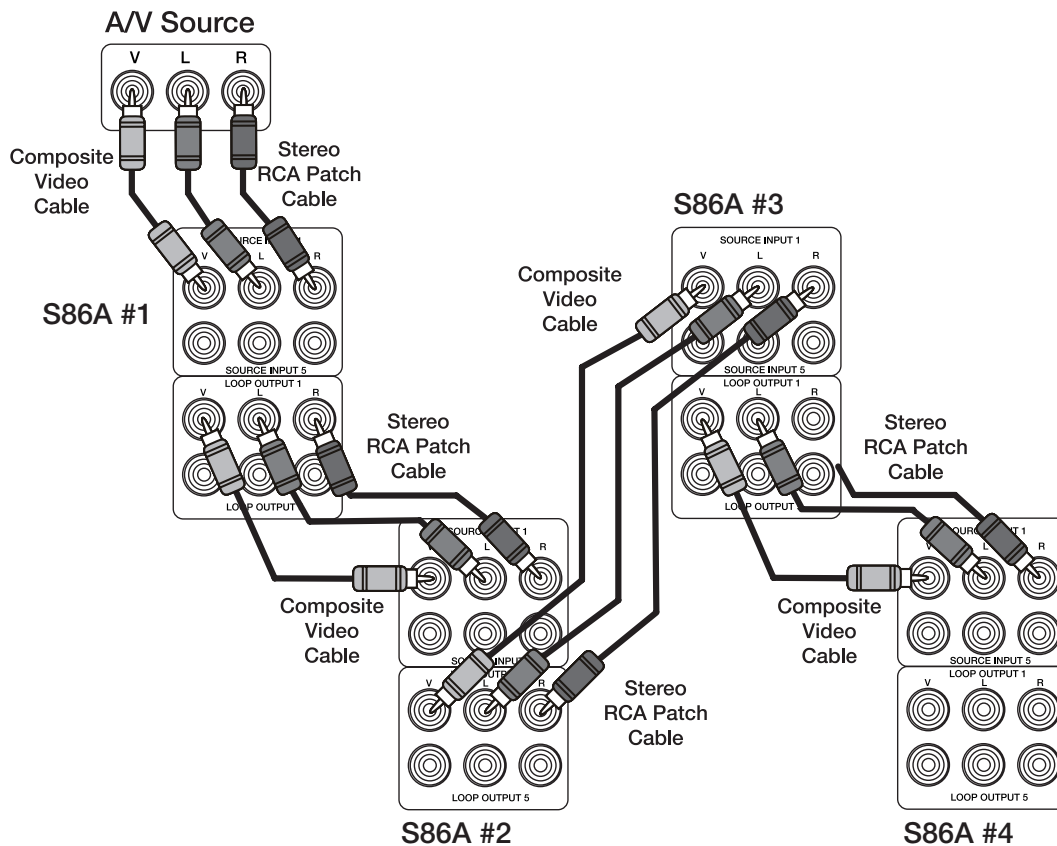

Figure 3-51: Multi-Chassis Loop Output/Source Input Connections

Source IR Expansion Ports

Use the DB15 Cables included with the S12XK KIT to connect the SOURCE IR EXPANSION PORTS between chassis as shown in *Figure 3-52*.

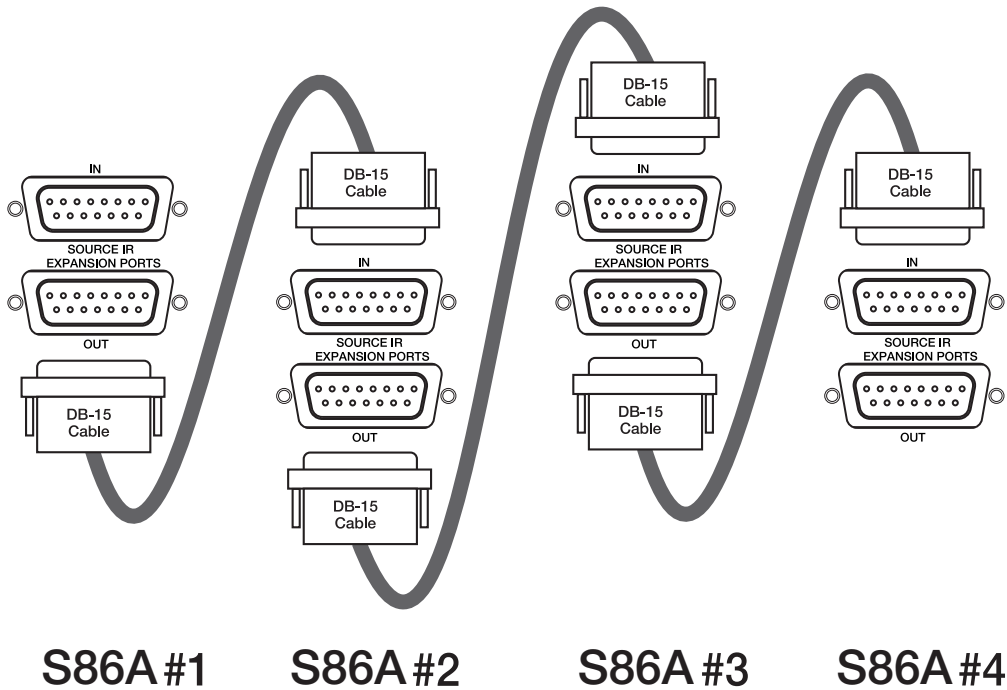

Figure 3-52: Multi-Chassis Source IR Expansion Port Connections

VIA!NET IN/OUT Ports

Use RJ-45 Interconnect Cables to connect The VIA!NET OUT port of Chassis #1 to the VIA!NET IN port on Chassis #2. Follow this pattern for additional chassis as shown in *Figure 3-53*.

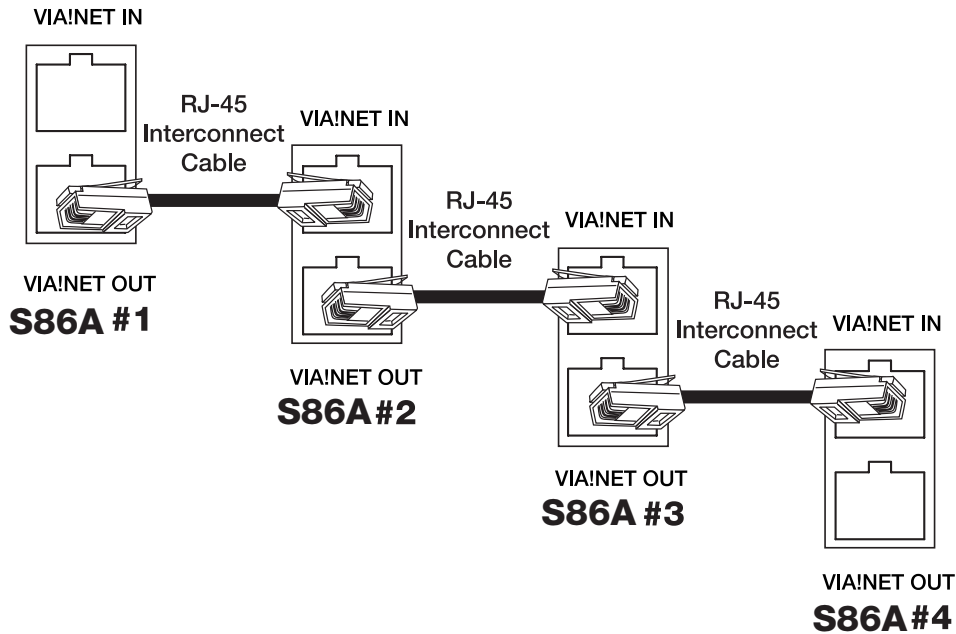

Figure 3-53: Multi-Chassis Source IR Expansion Port Connection

ELAN RS-232 Ports

Use the DB-9 connectors included in the S12XK Kit to connect the ELAN RS-232 PORTS as shown in *Figure 3-54* if RS-232 is being used to control the S86A system. These connections are not necessary if controlling the S86A with IR. These connections are not required for RS-232 devices that are connected to an ELAN SS1 System Station or SC-4 System Controller.

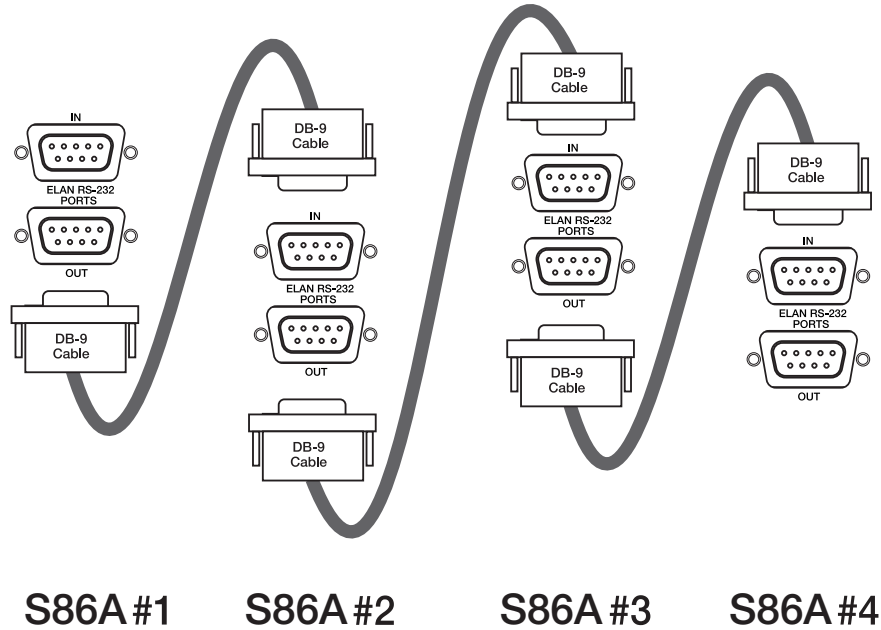

Figure 3-54: Multi-Chassis ELAN RS-232 Connections

C2 Connections

If using ELAN's C2 Communications Controller with the S86A, it is necessary to connect PAGE TRIGGER OUT from S86A #1 to the PAGE TRIGGER IN of S86A #2 using a 3.5mm mono interconnect cable. Follow the same pattern for additional S86A chassis. Use a stereo RCA interconnect cable (or two mono cables) to connect the PG/DB OUT port from the C2 to the PG IN connection of S86A #1 and the MOH OUT from S86A #1 to the MOH IN port on the C2. Use mono RCA interconnect cables to route audio from the PG OUT connector on S86A #1 to the PG IN connector on S86A #2. Follow this patter for additional S86A chassis as show in *Figure 3-55*.

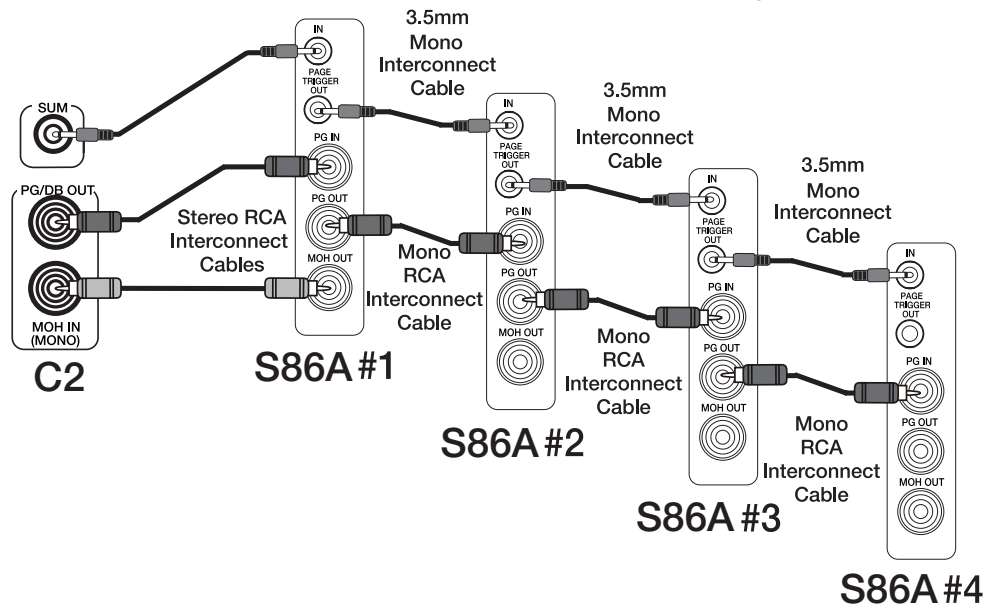

Figure 3-55: Multi-Chassis C2 Connections

AC Power Connector

The AC Power Connector connects to a 120VAC (240VAC for International model) power source to provide power to the S86A Multi-Room Integrated Controller (see *Figure 3-56*).

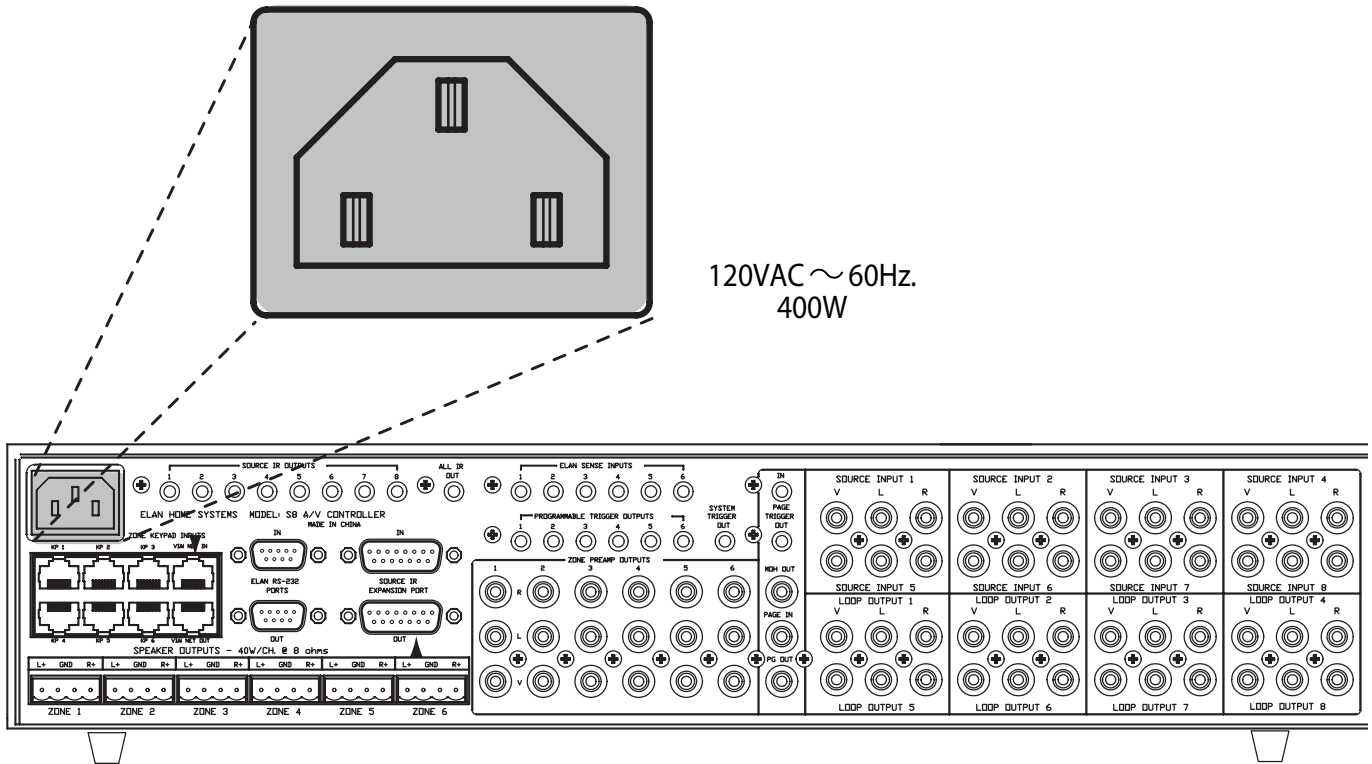

Figure 3-56: AC Power Receptacle

Chapter 4: Operation and Settings

Access Door

The Access Door on the Front Panel allows access to DIP switches and the USB Download port. (see *Figure 4-1*). The door may be pulled open using Access Point A or by pushing Access Point B, the door swings out.

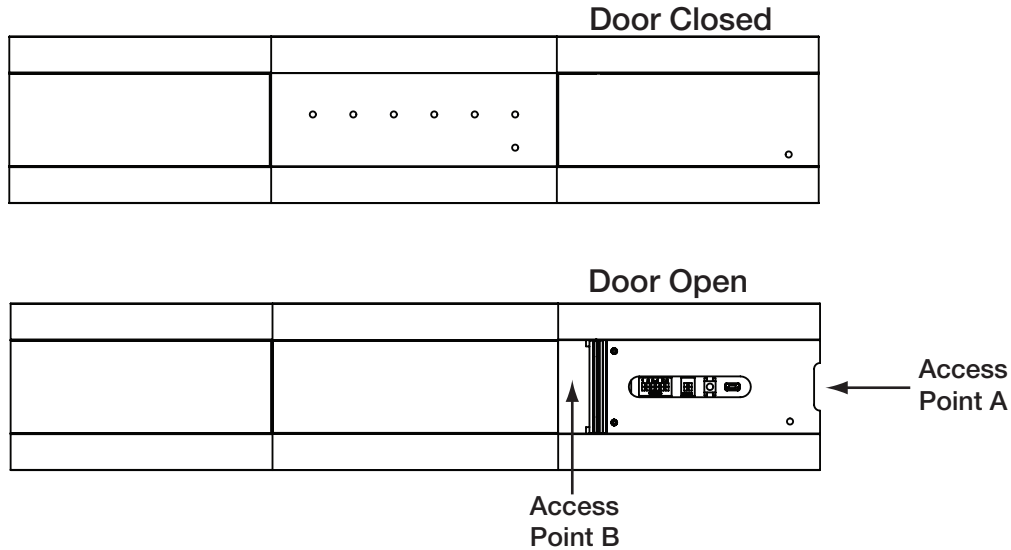

Figure 4-1: Pull-Open Access Door

Unit ID DIP Switch Settings

The S86A has two DIP switches on the front panel located behind the Access Door used for Unit ID addressing when connecting multiple S86A chassis (see *Figure 4-2*). Factory Default position is Unit ID #1 (UP, UP). Single-chassis systems require Unit ID #1 setting (UP, UP).

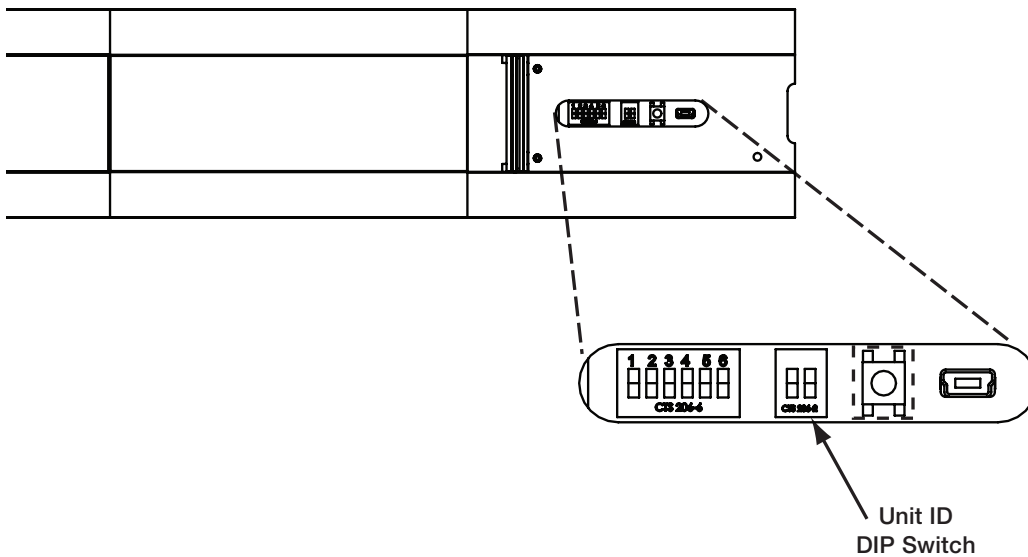

Figure 4-2: Unit ID DIP Switch

UNIT ID DIP Switches

Figure 4-3 shows the correct UNIT ID DIP Switch settings for each chassis. Factory Default is Unit ID #1 (UP, UP).

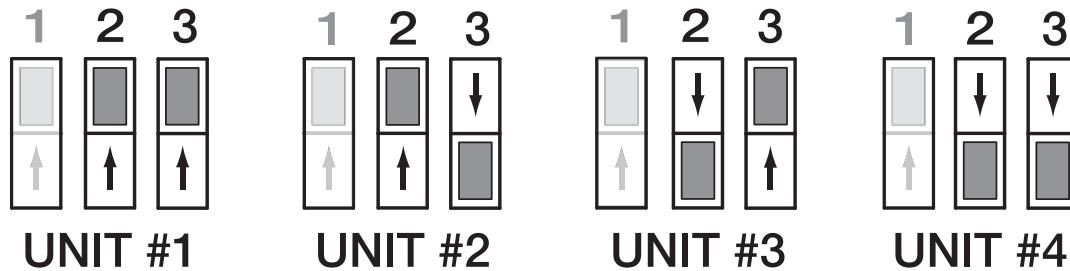

Figure 4-3: UNIT ID DIP Switch Settings

Front Panel LEDs

The S86A has six Zone Activity Status LEDs, an IR Activity LED, and a Power LED indicator (see Figure 4-4). The Zone Activity Status LEDs are lit when a zone is active and an IR Activity LED will flash when IR signals are sent from a particular zone.

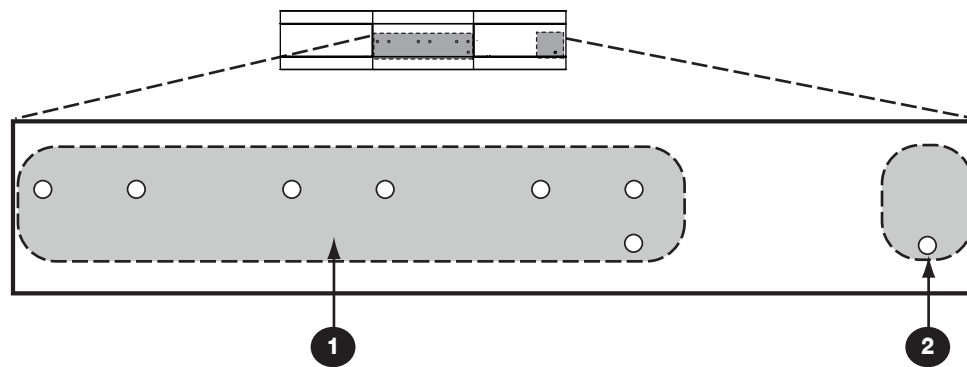

Figure 4-4: Front Panel LEDs

Item#	Name	Item#	Name
1	6 Zone ON/OFF Status LEDs (Red) & IR Activity (Green)	2	Power LED (Blue)

Table 4-1: S86A Front Panel LEDs

Chapter 5: Troubleshooting

The tables in Chapter 4 provide troubleshooting symptoms along with possible causes and corrections for the S86A Multi-Room Controller.

Table 5-1 Audio Troubleshooting Procedures

Symptom	Possible Cause/s	What an authorized installer can do
No audio in a specific zone.	<ol style="list-style-type: none"> 1. Source not playing. 2. No source selected in zone. 3. Source selected in wrong zone. IR zone controller (keypad etc.) connected to wrong zone 4. Variable output's volume turned all the way down. 5. Speakers or volume controls miswired or defective. 6. Zone audio output(s) connected to wrong amplifier input(s). 	<p>Press Play, tune station, turn on etc.</p> <p>Select source on front panel, keypad, or other zone controller.</p> <ol style="list-style-type: none"> a. Consult front panel display to determine Zone selection. b. Connect IR keypad or touch panel to correct zone. <p>Increase volume.</p> <p>Test known good speaker/volume control at amplifier.</p> <p>Verify connections.</p>
No audio present in any zone.	<ol style="list-style-type: none"> 1. See above. 2. External amplifier powered down. 3. External amp in protect mode. 	<p>Perform steps above.</p> <p>Turn amp ON. Ensure that any remote turn on cables are connected at both ends.</p> <p>Find cause of amp's protection mode and correct. Miswired speakers or volume controls most likely cause.</p>
Audio quits, zone LEDs turn off, no control over system, red power LED blinking slowly	Poor ventilation, fan failure.	<p>Check the ventilation.</p> <p>Check to see if the fans are working.</p> <p>Let the system cool until the power LED stops blinking, then turn the zone(s) on at a low volume. If problems persist, contact ELAN Technical Support.</p>

Table 5-1 Audio Troubleshooting Procedures

Symptom	Possible Cause/s	What an authorized installer can do
Audio "hum" or buzz through system speakers when audio playing.	<ol style="list-style-type: none"> 1. Ground Loop 2. Source Input level too high. 3. Faulty/damaged cables. 4. Faulty wiring. 	<ol style="list-style-type: none"> a. Ensure proper grounding using a three prong grounded AC outlet. b. Isolate problem by disconnecting each source one-by-one. <p>Reduce level settings in VIA!TOOLS or ELANTOOLS.</p> <p>Check source equipment cables for damaged cables and faulty connections.</p> <ol style="list-style-type: none"> a. Make sure any volume controls are not hooked up backwards. b. Check for shorts in wiring.
Poor Audio quality. Audio is unclear, Bass response is low.	<ol style="list-style-type: none"> 1. Speakers out of phase. 2. Incorrect left/right assignment of source or zone RCA cables. 3. Source level programming too high/too low. 	<p>Carefully check polarity of each speaker.</p> <p>Isolate to source or zone and correct.</p> <p>Increase/decrease source level (+9/- 6dB).</p>
Audio plays at full volume in a variable zone. No volume control with IR zone controller (Keypad, etc.).	<ol style="list-style-type: none"> 1. Fixed zone output connected to amp in variable zone. 2. Loop output connected instead of variable zone output 	<p>Set DIP switches to Variable.</p> <p>Connect Variable zone output to amplifier.</p>
No audio from one or more channels	<ol style="list-style-type: none"> 1. Loose/bad speaker cable connection 2. Break/short in speaker cable. 3. Speaker is defective. 4. Source not sending audio. 	<p>Check cable ends at binding posts and speaker terminals.</p> <p>Check continuity of each speaker cable using a multimeter. If short or open is indicated, check wiring for proper connections.</p> <p>Swap with known good speaker.</p> <p>Verify source is powered up and playing. Check any Tape Monitor settings on A/V Receiver.</p>
Audio very distorted in areas using volume controls	<p>Impedance-Match settings incorrect.</p> <p>Volume control miswired</p>	<p>Correct Impedance-Match jumper settings on volume control(s)</p> <p>Check for proper input/output connections at volume control. Input comes from amplifier, output goes to speakers.</p>

Table 5-1 Audio Troubleshooting Procedures

Symptom	Possible Cause/s	What an authorized installer can do
Distorted audio at normal volume levels	<ol style="list-style-type: none"> 1. Input level too high. 2. Defective/incompatible speaker. 3. Volume control miswired. 	<p>Reduce level settings in VIA!TOOLS or ELANTOOLS.</p> <ol style="list-style-type: none"> a. Check for physical damage to speaker. b. Ensure speakers have an appropriate power rating for amp. <p>Check for proper input/output connections at volume control. Input comes from amplifier, output goes to speakers.</p>
Hum in speakers when audio is not present.	Ground loop.	<p>Plug all sources into same AC outlet.</p> <p>Test AC outlet using ground tester.</p>

Table 5-2 Video Troubleshooting Procedures

Symptom	Possible Cause/s	What an authorized installer can do
No video to tv monitors or VIA! Touch Panels	<ol style="list-style-type: none"> 1. Source not playing. 2. No source selected in zone. 3. Wiring; video inputs and/or outputs incorrectly connected. 4. Programming; video inputs and/or outputs incorrectly programmed. 	<p>Press Play, Tune station etc.</p> <p>Select source on front panel, keypad, or other zone controller.</p> <p>Verify and correct wiring.</p> <p>Verify and correct programming.</p>
Video image is not optimal (ie., smeared, ghosted, blurry, or dull).	<ol style="list-style-type: none"> 1. Wiring; inhouse coax runs picking up noise from high voltage lines etc. 2. Wiring; coax has sharp bends or poor quality wire. 3. Source output too high. Certain satellite receivers have especially high output 	<p>Do not run video cables near AC lines. Cross AC lines at 90 degrees.</p> <p>Make gradual bends in coax when running wire. Use high quality wire.</p> <p>Use an RCA 'Y' cable with a 75 Ohm terminator connected to one leg. This will reduce the source output strength.</p>

Table 5-3 Triggers Troubleshooting Procedures

Symptom	Possible Cause/s	What an authorized installer can do
Sense Trigger Inputs: Triggered event fails to occur. Example: VIA! Touch Panel does not switch to Camera Mode.	1. Wiring; Sense Inputs incorrectly connected or incorrect type of Sensor/ faulty Sensor. 2. Programming; Sense Inputs incorrectly programmed in VIA!TOOLS or ELANTOOLS	a. Connect a 3.5 mm mono mini cable to Sense Input. This simulates a contact closure and should trigger the event. b. Replace Sensor or use different type Verify and correct programming. See VIA!TOOLS or ELANTOOLS Help file.
Zone/System Trigger Outputs: Triggered event fails to occur. Example: Amplifier does not turn ON when zone becomes active.	1. Wiring; bad mini-cable or using 3.5 mm stereo cable instead of mono. 2. Test for voltage w/ Digital Multi-Meter. 3. Programming	a. Must use MONO mini cable. b. Replace defective cable. Correct reading is +12 VDC. Correct programming in VIA!TOOLS or ELANTOOLS.
Page Trigger Inputs/Outputs: Triggered event fails to occur. Example: Volume Control Override does not function	Wiring: incorrect connections between C2 and S86A/SPP.	See 'Communications'

Table 5-4 Communications Troubleshooting Procedures

Symptom	Possible Cause/s	What an authorized installer can do
No Music-On-Hold	<ol style="list-style-type: none"> 1. Source #1 is not playing. 2. The MOH input level on the C2 is turned down. 	<p>Press Play, tune station, turn ON, etc.Adjust levels.</p> <p>Consult the C2 manual.</p>
No Page or Door Chime audio. Music does not mute when page or doorbell is activated.	<ol style="list-style-type: none"> 1. Zone is in Do-Not-Disturb. 2. Page/DB output from C2 is not connected to Page/DB input on S86A. 3. Page/DB trigger wiring incorrect between the S86A and the C2. 4. Programming 	<p>De-activate Do-Not-Disturb using IR or RS-232 commands.</p> <p>Correctly connect Page/DB Output from C2 to Page/DB Input on S86A. See C2 Connections</p> <p>Correct wiring error. See C2 Connections and the C2 manual.</p> <p>Check VIA!TOOLS or ELANTOOLS for the Disable checkbox.</p>
No Page or Door Chime audio. Music mutes when page or doorbell is activated.	<ol style="list-style-type: none"> 1. C2 Page/DB Output level turned all the way down. 2. Page/DB output from C2 not plugged into Page/DB input on S86A. 3. S86A has Volume set too low 	<p>Increase Page/DB level adjustment on C2.</p> <p>See Above.</p> <p>Increase setting on S86A, check VIA!TOOLS or ELANTOOLS program for volume setting.</p>

Table 5-5 Multi-Chassis Troubleshooting Procedures

Symptom	Possible Cause/s	What an authorized installer can do
In Chassis #2-4 only; •WHM, Paging, Doorbell, System Off do not function •Sense information not correct •IR information does not reach source equipment •Incorrect system On/Off status	IR/RS-485 Expansion ports not connected or incorrectly connected.	Connect Expansion Port OUT of Chassis #1 to Expansion Port IN of Chassis 2, etc. using ELAN's S12XK Expansion Kit.
In Chassis #2-4 only; •No RS-232 control of S86A •No RS-232 control of sources	RS-232 Serial ports not connected or incorrectly connected.	Connect RS-232 Serial Port OUT of Chassis #1 to RS-232 Serial Port IN of Chassis 2, etc. using ELAN's S12XK Expansion Kit.

Technical Support

If, after carefully following the steps in the **Troubleshooting** section, you are unable to resolve issues with the installation or operation of the S86A, please call ELAN Technical Support at 1-800-622-ELAN (3526).

Appendix A: Specifications

Table A-1 shows the equipment specifications for the S86A Multi-Room Integrated Controller.

Table A-1 S86A Multi-Room Integrated Controller Specifications

Item	Description
System	Multi-Source/Multi-Zone Integrated Controller
Source Inputs Input Sensitivity Input Impedance	0-2V RMS 47K Ohms
Pre-Amplifier Output Max. Output Power Frequency Response THD+Noise(@1KHz) Signal-to-Noise (A Weighted) Crosstalk (Zone to Zone) Output Impedance	6dB 20Hz to 20kHz, +/-0.5dB < 0.02% >95dB >105dB 600 Ohms
Amplifier Output Max. Output Power Speaker Impedance Frequency Response THD+Noise(@1KHz) Signal-to-Noise (A Weighted) Crosstalk (Zone to Zone)	40W @ 8 Ohms 8 Ohms 20Hz to 20kHz, +/-1dB < 0.02% >95dB >70dB
Music On Hold Output Output Impedance Max Output Level:	600 Ohms +6dB
Page & Doorbell Input Input Sensitivity Input Impedance	0-2V RMS 47k Ohms
Video Gain Bandwidth (-3dB) Gain Flatness (1dB) Input Impedance Output Impedance Crosstalk	Unity 12MHz 6MHz 75 Ohms 75 Ohms >40dB@3.58MHz

Appendix B: Programming

While the S86A Multi-Room Controller is designed to work right out of the box, VIA!TOOLS 8.0 & higher or ELANTOOLS Setup Software provides customized functionality for the specific environment for which it is being configured. Variables can be set for:

- IR Routing
- Trigger Output Functionality
- Page/DB Volume
- Page/DB Enable/Disable
- WHM/DND Enable/Disable
- Zone Turn On Volume
- Zone Bass/Treble/Loudness
- Source Input Levels

In order to download information into the S86A Controller, pull out on the Access Door from the right side of the S86A Front Panel. From a computer running Windows XP or Vista connect a standard USB A to USB Mini B cable to the USB Download port on the front of the S86A.

Note: Consult VIA!TOOLS or ELANTOOLS HELP file for specific programming steps.

Note: Once programming steps are completed, remove power for the S86A, then reapply power in order to reboot the unit.

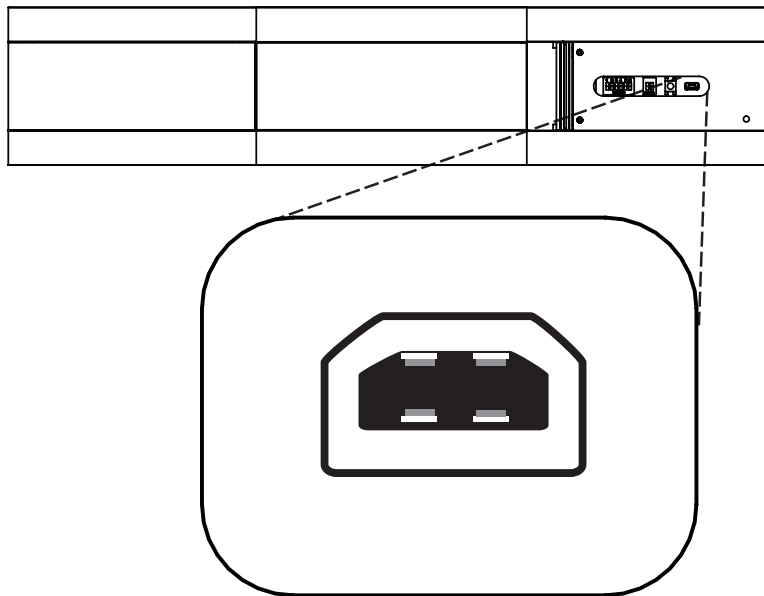

Figure B-1: USB Download Port

Appendix C: RS-232 Serial Control Commands

General Information

The S86A serial interface is a 3-wire RS-232 (Tx, Rx, Ground-Pins 2, 3, and 5 respectively).

S86A Communication Port Settings

Baud Rate: 19200
Data Bits: 8
Parity: None
Stop Bits: 1
Flow Control: None

All commands are in all capitals and the comma separation is required.

- Prefix: Must be present for every command string (Required)
- Command: See list below for all commands (Required)
- Parameter 1: Usually Zone 01-24 command
(Optional for some commands, required for others)
- Parameter 2
(Optional for some commands, required for others)
- Carriage Return: 0x0d or Decimal 13 (Required)

&S86, cmd, par 1, par 2 <cr>

&ELAN

&ELAN may be used as the prefix on S128P and S86A system controllers interchangeably. Some commands have a different range of values, for example, there are 12 sources in the S12 and only 8 sources in the S86A. There are no differences in the commands for an S86A and the S86P.

&S86,ACK

&S86,ACK<cr> is a command that is transmitted by the S86A whenever it receives a command with the correct structure. It does not mean that the command was performed. To ensure that the command was performed correctly, the S86A needs to be queried.

The following are correct serial command structures:

- &S86,SYSOFF
- &S86,PWR,01,1

If &S86,SYSOFF command is transmitted to the S86A, the S86A will respond with &S86,ACK. If &S86,PWR,100,1 is transmitted to the S86A, the S86A will NOT respond with a &S86,ACK because 100 is out of the scope. That field supports Zones 01-24 for this particular command. If there is only one S86A in the System, Zones 1-6, and &S86,PWR,09,1 is transmitted to the S86A, the S86A will NOT respond with a &S86,ACK because Chassis 1 does not support Zone 09. Chassis 1 supports Zones 01-06 for this particular command.

If an &S86,ACK is not received within 200ms:

- the command was formatted incorrectly
- an error has occurred in the S86A
- serial cable not connected or defective
- S86A does not have power

The S86A requires at least 50ms between each serial command transmitted to it. However, if the &S86,ACK is received prior to 50ms, another command can be transmitted immediately.

RS-232 Commands

The following list contains the RS-232 commands for the S86A. These commands are included in the IR Library of VIA!TOOLS or ELANTOOLS. Please refer to VIA!TOOLS or ELANTOOLS Help for specific information about these commands and how to use them.

There are four types of commands:

- System Commands
- Video Commands
- Audio Commands
- Query Commands

System Commands

BAS (Bass)

Description:

- Sets Zone zz to bass xy.
- Increment Zone zz bass.
- Decrement Zone zz bass.
- Has no effect if zone is off.
- If sending 00, the + or - can be omitted.

Command:

&S86,BAS,zz,a<cr>

&S86,BAS,zz,xy<cr>

Query:

&S86,BAS,zz?<cr>

Reply:

&S86,BAS,zz,xy<cr>

Parameters:

<cr>:

carriage return: Hexadecimal 0x0D or Decimal 13

zz:

Zone: 01-24

a:

+ = Increments by 1 step of 2dB (plus symbol)

- = Decrements by 1 step of 2dB (minus symbol)

x:

+ Sets to positive number (plus symbol)

- Sets to negative number (minus symbol)

y:

0 - 6

0 = Flat

Examples:

- &S86,BAS,13,+<cr> Increments Zone 13's bass by 1 step.
- &S86,BAS,02?<cr> queries Zone 2 for its bass.
- &S86,BAS,13,-2<cr> sets Zone 13's bass to -4 dB.
- &S86,BAS,13,0<cr> Zone 13 bass is flat

DND (Do Not Disturb)

Description:

- Turns specified Zone zz's DND off/on/toggle.
- Works if zone is off or on.

Command:

&S86,DND,zz,a<cr>

Query:

&S86,DND,zz?<cr>

Reply:

&S86,DND,zz,a<cr>

Parameters:

<cr>:

carriage return: Hexadecimal 0x0D or Decimal 13

zz:

Zone: 01-24

a:

0 = OFF

1 = ON

2 = TOG

Examples:

- &S86,DND,13,0<cr> turns Zone 13's DND off.
- &S86,DND,02?<cr> queries Zone 2's DND.
- &S86,DND,13,1<cr> turns Zone 13's DND on.
- &S86,DND,13,2<cr> toggles Zone 13's DND from on to off or off to on.

DB**Description:**

- Turns specified DB off/on/toggle. This will initiate a DB that will route audio present at the S86's Page In audio jack to zones that have DB enabled.
- Works if the System/Zone is on or off.
- Only chassis one will respond.

Command:

&S86,DB,a<cr>

Query:

&S86,DB?<cr>

Reply:

&S86,DB,a<cr>

Parameters:

<cr>:

carriage return: Hexadecimal 0x0D or Decimal 13

a:

0 = OFF

1 = ON

2 = Toggle

Examples:

- &S86,DB,0<cr> turns Doorbell off.
- &S86,DB?<cr> queries Doorbell status.
- &S86,DB,2<cr> toggles Doorbell from on to off or off to on.

KEY

Description:

These are the same commands as the S86A IR commands.

Command:

&S86,KEY,zz,abcd<cr>

Query:

N/A

Reply:

N/A

Parameters:

<cr>:

carriage return: Hexadecimal 0x0D or Decimal 13

zz:

Zone: 01-24

abcd:

0000 = All zones off (System OFF)

0004 = Return all zones to previous audio source (Page OFF)

0005 = Route 'Page Aud In' to all enabled zones (Page ON group 0)

0006 = Page on/off toggle - group 0

0007 = Return all zones to previous audio source (Doorbell OFF)

0008 = Route 'Page Aud In' to all zones (Doorbell ON)

0009 = Doorbell on/off toggle

0010 = Allow zone to be included in WHM & PAGE (DND OFF)

0011 = Exempt zone from WHM & PAGE (DND ON)

0012 = Do Not Disturb on/off toggle

0013 = All zones independent - no source tracking (WHM OFF)

0014 = All zones track current A/V source (WHM ON)

0015 = Whole House Music on/off toggle

0016 = Zone OFF

0017 = Zone ON

0018 = Zone ON/OFF toggle

0019 = Zone audio unmute

0020 = Zone audio mute

0021 = Zone audio mute toggle

0022 = Disable loudness filter

0023 = Enable loudness filter

0024 = Loudness on/off toggle

0024 = Zone treble down (XdB steps, Z steps)

0032 = Zone treble up (XdB steps, Z steps)

0033 = Zone bass down (XdB steps, Z steps)

0034 = Zone bass up (XdB steps, Z steps)

0035 = Zone volume down (Xdb step, Y steps)

0036 = Zone volume up (Xdb step, Y steps)

0037 = Page volume down (Xdb step, Y steps)

0038 = Page volume up (Xdb step, Y steps)

0039 = Doorbell volume down (Xdb step, Y steps)

0040 = Doorbell volume up (Xdb step, Y steps)

0041 = Source level adjustment down (Xdb step, Y steps)

0042 = Source level adjustment up (Xdb step, Y steps)

0043 = Zone EQ Flat - return bass & treble to 0dB

0047 = Video Mute (based on zone IR)

0048 = Select Combined A/V Source 1

0049 = Select Combined A/V Source 2

0050 = Select Combined A/V Source 3

0051 = Select Combined A/V Source 4

0052 = Select Combined A/V Source 5

0053 = Select Combined A/V Source 6

0054 = Select Combined A/V Source 7

0055 = Select Combined A/V Source 8

0064 = Select Audio Source 1

0065 = Select Audio Source 2

0066 = Select Audio Source 3

0067 = Select Audio Source 4

0068 = Select Audio Source 5

0069 = Select Audio Source 6

0070 = Select Audio Source 7

0071 = Select Audio Source 8

0080 = VIDEO OUTPUT 1

0081 = VIDEO OUTPUT 2

0082 = VIDEO OUTPUT 3

0083 = VIDEO OUTPUT 4

0084 = VIDEO OUTPUT 5

0085 = VIDEO OUTPUT 6

0096 = VIDEO INPUT 1

0097 = VIDEO INPUT 2

0098 = VIDEO INPUT 3

0099 = VIDEO INPUT 4

0100 = VIDEO INPUT 5

0101 = VIDEO INPUT 6

0102 = VIDEO INPUT 7

0103 = VIDEO INPUT 8

0176 = Following Command is for Zone 1

0177 = Following Command is for Zone 2

0178 = Following Command is for Zone 3

0179 = Following Command is for Zone 4

0180 = Following Command is for Zone 5

0181 = Following Command is for Zone 6

0182 = Following Command is for Zone 7
0183 = Following Command is for Zone 8
0184 = Following Command is for Zone 9
0185 = Following Command is for Zone 10
0186 = Following Command is for Zone 11
0187 = Following Command is for Zone 12
0188 = Following Command is for Zone 13
0189 = Following Command is for Zone 14
0190 = Following Command is for Zone 15
0191 = Following Command is for Zone 16
0192 = Following Command is for Zone 17
0193 = Following Command is for Zone 18
0194 = Following Command is for Zone 19
0195 = Following Command is for Zone 20
0196 = Following Command is for Zone 21
0197 = Following Command is for Zone 22
0198 = Following Command is for Zone 23
0199 = Following Command is for Zone 24

0256 = Trigger Output 1 OFF
0257 = Trigger Output 2 OFF
0258 = Trigger Output 3 OFF
0259 = Trigger Output 4 OFF
0260 = Trigger Output 5 OFF
0261 = Trigger Output 6 OFF
0262 = Trigger Output 7 OFF
0263 = Trigger Output 8 OFF
0264 = Trigger Output 9 OFF
0265 = Trigger Output 10 OFF
0266 = Trigger Output 11 OFF

0267 = Trigger Output 12 OFF
0268 = Trigger Output 13 OFF
0269 = Trigger Output 14 OFF
0270 = Trigger Output 15 OFF
0271 = Trigger Output 16 OFF
0272 = Trigger Output 17 OFF
0273 = Trigger Output 18 OFF
0274 = Trigger Output 19 OFF
0275 = Trigger Output 20 OFF
0276 = Trigger Output 21 OFF
0277 = Trigger Output 22 OFF
0278 = Trigger Output 23 OFF
0279 = Trigger Output 24 OFF
0288 = Trigger Output 1 ON
0289 = Trigger Output 2 ON
0290 = Trigger Output 3 ON
0291 = Trigger Output 4 ON
0292 = Trigger Output 5 ON
0293 = Trigger Output 6 ON
0294 = Trigger Output 7 ON
0295 = Trigger Output 8 ON
0296 = Trigger Output 9 ON
0297 = Trigger Output 10 ON
0298 = Trigger Output 11 ON
0299 = Trigger Output 12 ON
0300 = Trigger Output 13 ON
0301 = Trigger Output 14 ON
0302 = Trigger Output 15 ON
0303 = Trigger Output 16 ON

0304 = Trigger Output 17 ON

0305 = Trigger Output 18 ON

0306 = Trigger Output 19 ON

0307 = Trigger Output 20 ON

0308 = Trigger Output 21 ON

0309 = Trigger Output 22 ON

0310 = Trigger Output 23 ON

0311 = Trigger Output 24 ON

0320 = Trigger Output 1 TOGGLE

0321 = Trigger Output 2 TOGGLE

0322 = Trigger Output 3 TOGGLE

0323 = Trigger Output 4 TOGGLE

0324 = Trigger Output 5 TOGGLE

0325 = Trigger Output 6 TOGGLE

0326 = Trigger Output 7 TOGGLE

0327 = Trigger Output 8 TOGGLE

0328 = Trigger Output 9 TOGGLE

0329 = Trigger Output 10 TOGGLE

0330 = Trigger Output 11 TOGGLE

0331 = Trigger Output 12 TOGGLE

0332 = Trigger Output 13 TOGGLE

0333 = Trigger Output 14 TOGGLE

0334 = Trigger Output 15 TOGGLE

0335 = Trigger Output 16 TOGGLE

0336 = Trigger Output 17 TOGGLE

0337 = Trigger Output 18 TOGGLE

0338 = Trigger Output 19 TOGGLE

0339 = Trigger Output 20 TOGGLE

0340 = Trigger Output 21 TOGGLE
0341 = Trigger Output 22 TOGGLE
0342 = Trigger Output 23 TOGGLE
0343 = Trigger Output 24 TOGGLE
0352 = System Trigger Output Unit 1 ON
0353 = System Trigger Output Unit 2 ON
0354 = System Trigger Output Unit 3 ON
0355 = System Trigger Output Unit 4 ON
0356 = System Trigger Output Unit 1 OFF
0357 = System Trigger Output Unit 2 OFF
0358 = System Trigger Output Unit 3 OFF
0359 = System Trigger Output Unit 4 OFF
0360 = System Trigger Output Unit 1 TOGGLE
0361 = System Trigger Output Unit 2 TOGGLE
0362 = System Trigger Output Unit 3 TOGGLE
0363 = System Trigger Output Unit 4 TOGGLE
0400 = VIDEO MUTE 1
0401 = VIDEO MUTE 2
0402 = VIDEO MUTE 3
0403 = VIDEO MUTE 4
0404 = VIDEO MUTE 5
0405 = VIDEO MUTE 6
0512 = VIDEO OUTPUT1 INPUT1
0513 = VIDEO OUTPUT1 INPUT2
0514 = VIDEO OUTPUT1 INPUT3
0515 = VIDEO OUTPUT1 INPUT4
0516 = VIDEO OUTPUT1 INPUT5
0517 = VIDEO OUTPUT1 INPUT6
0518 = VIDEO OUTPUT1 INPUT7

0519 = VIDEO OUTPUT1 INPUT8
0528 = VIDEO OUTPUT2 INPUT1
0529 = VIDEO OUTPUT2 INPUT2
0530 = VIDEO OUTPUT2 INPUT3
0531 = VIDEO OUTPUT2 INPUT4
0532 = VIDEO OUTPUT2 INPUT5
0533 = VIDEO OUTPUT2 INPUT6
0534 = VIDEO OUTPUT2 INPUT7
0535 = VIDEO OUTPUT2 INPUT8
0544 = VIDEO OUTPUT3 INPUT1
0545 = VIDEO OUTPUT3 INPUT2
0546 = VIDEO OUTPUT3 INPUT3
0547 = VIDEO OUTPUT3 INPUT4
0548 = VIDEO OUTPUT3 INPUT5
0549 = VIDEO OUTPUT3 INPUT6
0550 = VIDEO OUTPUT3 INPUT7
0551 = VIDEO OUTPUT3 INPUT8
0560 = VIDEO OUTPUT4 INPUT1
0561 = VIDEO OUTPUT4 INPUT2
0562 = VIDEO OUTPUT4 INPUT3
0563 = VIDEO OUTPUT4 INPUT4
0564 = VIDEO OUTPUT4 INPUT5
0565 = VIDEO OUTPUT4 INPUT6
0566 = VIDEO OUTPUT4 INPUT7
0567 = VIDEO OUTPUT4 INPUT8
0576 = VIDEO OUTPUT5 INPUT1
0577 = VIDEO OUTPUT5 INPUT2
0578 = VIDEO OUTPUT5 INPUT3
0579 = VIDEO OUTPUT5 INPUT4

0580 = VIDEO OUTPUT5 INPUT5

0581 = VIDEO OUTPUT5 INPUT6

0582 = VIDEO OUTPUT5 INPUT7

0583 = VIDEO OUTPUT5 INPUT8

0592 = VIDEO OUTPUT6 INPUT1

0593 = VIDEO OUTPUT6 INPUT2

0594 = VIDEO OUTPUT6 INPUT3

0595 = VIDEO OUTPUT6 INPUT4

0596 = VIDEO OUTPUT6 INPUT5

0597 = VIDEO OUTPUT6 INPUT6

0598 = VIDEO OUTPUT6 INPUT7

0599 = VIDEO OUTPUT6 INPUT8

Examples:

- &S86,KEY,13,0000<cr> turns System off.
- &S86,KEY,02,0004<cr> turns Zone 2 Page off
- &S86,KEY,13,0009<cr> turns Zone 13 Doorbell off to on or on to off.

MUT (Mute)

Description:

- Controls the mute function of specified Zone zz

Command:

&S86,MUT,zz,a<cr>

Query:

&S86,MUT,zz?<cr>

Reply:

&S86,MUT,zz,a<cr>

Parameters:

<cr>:

carriage return: Hexadecimal 0x0D or Decimal 13

zz:

Zone: 01-24

a:

0 = OFF

1 = ON

2 = TOG

Examples:

- &S86,MUT,13,0<cr> turns Zone 13's Mute off.
- &S86,MUT,02?<cr> queries Zone 2's Mute.
- &S86,MUT,13,1<cr> turns Zone 13's Mute on.
- &S86,MUT,13,2<cr> toggles Zone 13's Mute from on to off or off to on.

PWR (Power)

Description:

- Turns specified Zone zz off/on/toggle.
- Zone turns on to last selected source.

Command:

&S86,PWR,zz,a<cr>

Query:

&S86,PWR,zz?<cr>

Reply:

&S86,PWR,zz,a<cr>

Parameters:

<cr>:

carriage return: Hexadecimal 0x0D or Decimal 13

zz:

Zone: 01-24

a:

0 = OFF

1 = ON

2 = TOG

Examples:

- &S86,PWR,13,0<cr> turns Zone 13 off.
- &S86,PWR,02?<cr> queries Zone 2.
- &S86,PWR,13,1<cr> turns Zone 13 on.
- &S86,PWR,13,2<cr> toggles Zone 13 from on to off or off to on.

SRC (Source)

Description:

- Selects a specified Source as in a Zone zz.
- Automatically switches both audio and video inputs.
- If the zone is off, zone will turn on with ss = 01-08.

Command:

&S86,SRC,zz,ss<cr>

Query:

&S86,SRC,zz?<cr>

Reply:

&S86,SRC,zz,ab<cr>

&S86,SRC,zz,A/V MATRIX MODE<cr> if audio and video are different sources.

Parameters:

<cr>:

carriage return: Hexadecimal 0x0D or Decimal 13

zz:

Zone: 01-24

ss:

Source 01-08

00 is zone off

Examples:

- &S86,SRC,13,01<cr> selects Source 1 in Zone 13.
- &S86,SRC,02?<cr> queries Zone 2 for selected source.
- &S86,SRC,09,00<cr> turns Zone 9 off

SYSOFF (System Off)

Description:

- Turns all zones off.
- Only Chassis 1 will respond.

Command:

&S86,SYSOFF<cr>

Query:

&S86,SYSOFF?<cr>

Reply:

&S86,SYSOFF,a<cr>

Parameters:

<cr>:

carriage return: Hexadecimal 0x0D or Decimal 13

a:

0 = OFF

1 = ON

Examples:

- &S86,SYSOFF<cr> turns System off.
- &S86,SYSOFF?<cr> queries System status.
- &S86,SYSOFF,0<cr> S86A returns System is off.

TRE (Treble)

Description:

- Sets Zone zz to treble xyz.
- Increment Zone zz treble.
- Decrement Zone zz treble.
- Has no affect if zone is off.
- If sending 00, the + or - can be omitted.

Command:

&S86,TRE,zz,a<cr>

&S86,TRE,zz,xy<cr>

Query:

&S86,TRE,zz?<cr>

Reply:

&S86,TRE,zz,xyz<cr>

Parameters:

<cr>:

carriage return: Hexadecimal 0x0D or Decimal 13

zz:

Zone: 01-24

a:

+ = Increments by 1 step of 2dB (plus symbol)

- = Decrements by 1 step of 2dB(minus symbol)

x:

+ Sets to positive number (plus symbol)

- Sets to negative number (minus symbol)

y:

0 - 6

0 = Flat

Examples:

- `&S86,TRE,13,+<cr>` Increments Zone 13's treble by 1 step.
- `&S86,TRE,02?<cr>` queries Zone 2 for its treble.
- `&S86,TRE,13,-2<cr>` sets Zone 13's treble to -4dB
- `&S86,TRE,3,0<cr>` Zone 3 treble is flat.

VOL (Volume)

Description:

- Sets Zone zz to volume abc.
- Increment Zone zz volume.
- Decrement Zone zz volume.
- Volume increment will end mute.

Command:

`&S86,VOL,zz,a<cr>`

`&S86,VOL,zz,abc<cr>`

Query:

`&S86,VOL,zz?<cr>`

Reply:

`&S86,VOL,zz,abc<cr>`

Parameters:

`<cr>`:

carriage return: Hexadecimal 0x0D or Decimal 13

`zz`:

Zone: 01-24

`a`:

+ = Increments by 1 step (plus symbol)

- = Decrements by 1 step (minus symbol)

abc:

000 – 100 (percent volume level)

000 = Mute

Examples:

- &S86,VOL,13,+<cr> Increments Zone 13's volume.
- &S86,VOL,02?<cr> queries Zone 2 for its volume.
- &S86,VOL,13,19<cr> sets Zone 13's volume to 19%.
- &S86,VOL,13,000<cr> mutes Zone 13.

WHM (Whole House Music)

Description:

- Turns specified Zone zz's WHM off/on/toggle.
- Has no effect if the zone is off.
- If zone is turned off, WHM is disabled.

Command:

&S86,WHM,zz,a<cr>

Query:

&S86,WHM,zz?<cr>

Reply:

&S86,WHM,zz,a<cr>

Parameters:

<cr>:

carriage return: Hexadecimal 0x0D or Decimal 13

zz:

Zone: 01-24

a:

0 = OFF

1 = ON

2 = TOG

Examples:

- &S86,WHM,13,0<cr> turns Zone 13's WHM off.
- &S86,WHM,02?<cr> queries Zone 2's WHM.
- &S86,WHM,13,1<cr> turns Zone 13's WHM on.
- &S86,WHM,13,2<cr> toggles Zone 13's WHM from on to off or off to on.

The Following Commands Are Significantly Different From The S12 System

Controller:

LUD (Loudness)

Description:

- Turns loudness feature of specified Zone zz
- Has no effect if the zone is off.

Command:

&S86,LUD,zz,a<cr>

Query:

&S86,LUD,zz?<cr>

Reply:

&S86,LUD,zz,a<cr>

Parameters:

<cr>:

carriage return: Hexadecimal 0x0D or Decimal 13

zz:

Zone: 01-24

a:

0 = OFF

1 = ON

2 = TOG

Examples:

- &S86,LUD,13,0<cr> turns Zone 13's Loudness off.
- &S86,LUD,02?<cr> queries Zone 2's Loudness.
- &S86,LUD,13,1<cr> turns Zone 13's Loudness on.
- &S86,LUD,13,2<cr> toggles Zone 13's Loudness from on to off or off to on.

PG**Description:**

- Turns PG off/on/toggle. This will initiate a PG that will route audio present at the S86A's

Page In audio jack to all zones that have PG enabled.

- Works if the System/Zone is on or off.

Command:

&S86,PG,0,a<cr>

Query any page activity:

&S86,PG?<cr>

Reply:

&S86,PG,a<cr>

Parameters:

<cr>:

carriage return: Hexadecimal 0x0D or Decimal 13

a:

0 = OFF

1 = ON

2 = Toggle

Examples:

- &S86,PG,0,1<cr> Activates all zones to Page ON.
- &S86,PG,0,2<cr> Toggles all zones Page from on to off or off to on.

TRI (Trigger Output)

Description:

- Turns specified Programmable Trigger Output's state off/on/toggle.
- Only works if Trigger is enabled in VIA!TOOLS or ELANTOOLS

Command:

&S86,TRI,tt,a<cr>

Query:

&S86,TRI,tt?<cr>

Reply:

&S86,TRI,tt,a<cr>

Parameters:

<cr>:

carriage return: Hexadecimal 0x0D or Decimal 13

tt:

Trigger Output: 1-24

a:

0 = OFF

1 = ON

2 = TOG

Examples:

- &S86,TRI,13,0<cr> turns Trigger Output 13 off.
- &S86,TRI,03,2<cr> toggles Trigger Output 3 from on to off or off to on.

Video Commands

VID (Video)

Description:

Switches S86A video outputs in Zone zz to a specific Video a input.

Command:

&S86,VID,zz,a<cr>

Query:

&S86,VID,zz?<cr>

Reply:

&S86,VID,zz,a<cr>

Parameters:

<cr>:

carriage return: Hexadecimal 0x0D or Decimal 13

zz:

Zone: 01-24

a:

Input 0-8, where zero is video mute.

Examples:

- &S86,VID,03,2<cr> S86 Zone 3 selects Input 2.
- &S86,VID,20?<cr> Queries S86 in Zone 20 for selected video input.
- &S86,VID,07,7<cr> S86 in Zone 7 selects Input 7.

Audio Commands

AUD (Audio)

Description:

Switches S86A audio outputs in Zone zz to a specific Audio a input.

Command:

```
&S86,AUD,zz,a<cr>
```

Query:

```
&S86,AUD,zz?<cr>
```

Reply:

```
&S86,AUD,zz,a<cr>
```

Parameters:

<cr>:

carriage return: Hexadecimal 0x0D or Decimal 13

zz:

Zone: 01-24

a:

Input 1-8

Examples:

- &S86,AUD,03,2<cr> S86 Zone 3 selects audio Input 2.
- &S86,AUD,20?<cr> Queries S86 in Zone 20 for selected audio input.
- &S86,AUD,07,7<cr> S86 in Zone 7 selects audio Input 7.

Query Commands

ASD (Audio Signal Detect)

Description:

- Queries Unit u Audio Source Inputs to determine if an audio signal is present.
- The S86 can either sense audio from the Left, Right or both Left and Right.
- The S86 can detect the audio instantaneously, however the it can take up to 30 seconds before the S86 detects the absence of audio once the audio is removed.
- Works if System is off or on.

Command:

N/A

Query:

```
&S86,ASD,u?<cr>
```

Reply:

```
&S86,ASD,u,aaaaaaaa<cr>
```

Parameters:

<cr>:

carriage return: Hexadecimal 0x0D or Decimal 13

u:

Unit 1-4

a:

0 = Not Detected

1 = Detected

Examples:

- &S86,ASD,1?<cr> Queries Unit 1.
- &S86,ASD,2?<cr> Queries Unit 2.
- &S86,ASD,1,11111100<cr> S86 Unit 1 reply.

Audio Signals 1 thru 6 are ON and Audio Signal 7-8 are OFF.

- &S86,ASD,2,00001000<cr> S86 Unit 2 reply.
Audio Signals 5 is ON, Audio Signals 1, 2,3, 4, 6, 7, and 8 are OFF

PGD (Page Detect Query)

Description:

- Queries Unit u to determine if the Page Trigger In jack is active.
- If all zones in a chassis/system do NOT have PG enabled, this command will still return the correct status of the Page Trigger In jack.
- PG enabled is programmed in VIA!TOOLS or ELANTOOLS S86 Init Screen Zones page.
- Works if System is off or on.

Command:

N/A

Query:

&S86,PGD,u?<cr>

Reply:

&S86,PGD,u,a<cr>

Parameters:

<cr>:

carriage return: Hexadecimal 0x0D or Decimal 13

u:

Unit 1-4

a:

0 = Off/Inactive

1 = On/Active

Examples:

- &S86,PGD,1?<cr> Queries Unit 1.
- &S86,PGD,1,0<cr> S86 Unit 1 reply. Page Trigger In jack is Off/Inactive.

STI (Sense Trigger Inputs)

Description:

- Queries Unit u's Sense Trigger Inputs to determine if they are on or off.
- You must have the expansion cable connected if more than one chassis is in the system.

If you do not, the returned data will not be reliable.

Command:

N/A

Query:

&S86,STI,u?<cr>

Reply:

&S86,STI,u,aaaaaa<cr>

Parameters:

<cr>:

carriage return: Hexadecimal 0x0D or Decimal 13

u:

Unit 1-4

a:

0 = OFF

1 = ON

Examples:

- &S86,STI,1?<cr> Queries Unit 1.
- &S86,STI,2?<cr> Queries Unit 2.
- &S86,STI,1,111111<cr> S86 Unit 1 reply.

All Sense Trigger Inputs are ON.

- &S86,STI,2,000010<cr> S86 Unit 2 reply.

Sense Trigger Input 5 ON, Sense Trigger Inputs 1, 2, 3, 4 and 6 OFF.

VSD (Video Signal Detect)

Description:

- Queries Unit u Video Inputs to determine if a video signal is present.
- The S86 can detect the video instantaneously and detect the absence of video instantaneously.
- Works if System is off or on.

Command:

N/A

Query:

&S86,VSD,u?<cr>

Reply:

&S86,VSD,u,aaaaaaaa<cr>

Parameters:

<cr>:

carriage return: Hexadecimal 0x0D or Decimal 13

u:

Unit 1-4

a:

0 = Not Detected

1 = Detected

Examples:

- &S86,VSD,1?<cr> Queries Unit 1.
- &S86,VSD,2?<cr> Queries Unit 2.
- &S86,VSD,1,11111100<cr> S86A Unit 1 reply.

Video Signals 1 thru 6 are ON and Video Signals 7-8 are OFF.

- &S86,VSD,2,00001000<cr> S86A Unit 2 reply.

Video Signal 5 is ON, Video Signals 1, 2, 3, 4, 6, 7, and 8 are OFF.

VER (Firmware Version)

Description:

- Queries Unit u to determine firmware version.
- Works if System is off or on.

Command:

N/A

Query:

&S86,VER,u?<cr>

Reply:

&S86,VER,u,Firmware abcdefghijklmnop<cr>

Parameters:

<cr>:

carriage return: Hexadecimal 0x0D or Decimal 13

u:

Unit 1-4

abcdefghijklmnop:

Version can be variable length, 16 ASCII char maximum. Always begins with “&S86” even if command sent used the common system header of “&ELAN”

Examples:

- &S86,VER,1?<cr> Queries Unit 1.
- &ELAN,VER,2?<cr> Queries Unit 2.
- &S86,VER,1,Firmware 2.0.1.9<cr> S86 Unit 1 reply.
- &S86,VER,2,Firmware 2.0.2.0<cr> S86 Unit 2 reply.

QRY (Query Chassis)

Description:

- Replies with all the Zone status data for a requested chassis, u, in 6 byte hex format per zone, ABCDEF.
- Works if System is off or on.

Command:

N/A

Query:

&S86,QRY,u?<cr>

Reply:

&S86,QRY,u,ABCDEFABCDEFABCDEFABCDEFABCDEF <cr>

Parameters:

<cr>:

carriage return: Hexadecimal 0x0D or Decimal 13

u:

Unit ID: 1-4

The most significant bit is shown as “a” and least significant bit is shown as “h”:

A: abcdefgh:

100z zzzz = Zone Number (81h = Zone 1)

B: abcdefgh:

a = 0

b = System Status (0 = OFF, 1 = ON)

c = DND Status (0 = OFF, 1 = ON)

d = Mute Status (0 = OFF, 1 = ON)

e = Audio + Video Detect Status (0 = Neither Detected, 1 = Either one has been Detected)

fgh = Source Selected (0 = Zone OFF, 1-6 = Source 1-6, 7 = Source > 6 see next byte)

C: abcdefgh:

a = 0

b = WHM Status (0 = OFF, 1 = ON)

c = Page Trigger Status (0 = OFF, 1 = ON)

d = {DRC Status for S12 (0 = OFF, 1 = ON)} Always 0 for S86A

e = Loudness Status (0 = OFF, 1 = ON) {Always 0 for S12}

fgh = Source Selected (0 = Zone OFF, 1-6 = Source 7-12, 7 = Source < 6 see previous

byte)

D: abcdefgh:

a = 0

b = X usually 0, but could be 1

cdefgh = Volume Level(0 = Max, 48 = Min)

E: abcdefgh:

a = 0

b = X usually 0, but could be 1

c = X usually 0, but could be 1

defgh = Treble Level(28 = Max +dB, 4 = Min -dB)

F: abcdefgh:

a = 0

b = X usually 0, but could be 1

c = X usually 0, but could be 1

defgh = Bass Level(28 = Max +dB, 4 = Min -dB)

Examples:

- &S86,QRY,1?<cr> Queries chassis unit ID #1. Useful for third party UI.
- Given Zone 1 is ON with Source 2 playing at 50% volume level and flat EQ the reply for that zone would look like this in HEX format:

0x26 0x53 0x38 0x36 0x2C 0x51 0x52 0x59 0x2C 0x31 0x2C 0x81 0x4A 0x07 0x18

0x10 0x10.

NAM (Get Zone Name)

Description:

- Replies the Zone, zz, name stored in memory from VIA!TOOLS or ELANTOOLS called, abcdefghijklmno.
- Works if System is off or on.

Command:

N/A

Query:

&S86,NAM,zz?<cr>

Reply:

&S86,NAM,zz,abcdefghijklmno<cr>

Parameters:

<cr>:

carriage return: Hexadecimal 0x0D or Decimal 13

zz:

Zone: 1-24

abcdefghijklmno:

Name can be variable length of 14ASCII char maximum.

Examples:

- &S86,NAM,1?<cr> Queries where Zone 1's Name. Useful for third party UI.
- &S86,NAM,2,Master Bedroom<cr> Replies Zone 2's Name is Master Bedroom.
- &S86,NAM,1,Kitchen<cr> Replies Zone 1's Name is Kitchen.

SRCNAM (Get Source Name)

Description:

- Replies the source, s, name stored in memory from VIA!TOOLS or ELANTOOLS called, abcdefghijklmno.
- Works if System is off or on.

Command:

N/A

Query:

&S86,SRCNAM,s?<cr>

Reply:

&S86,SRCNAM,s,abcdefghijklmno<cr>

Parameters:

<cr>:

carriage return: Hexadecimal 0x0D or Decimal 13

s:

Source: 1-8

abcdefghijklmno:

Name can be variable length of 14ASCII char maximum.

Examples:

- &S86,SRCNAM,1?<cr> Queries where Source 1's Name. Useful for third party UI.
- &S86,SRCNAM,2,VIAdj<cr> Replies Source 2's Name is VIAdj.
- &S86,SRCNAM,1,DVDR<cr> Replies Source 1's Name is DVDR.

Restore Factory Defaults

Description:

- Resets system to factory default values.
- Works if System is off or on.

Command:

&S86,DEF<cr>

Appendix D: Rack Mounting

RMK3 Rack-Mount Kit

When mounting the S86A controller in an equipment rack, use the optional RMK3 Rack Mount Kit for secure mounting and proper ventilation. The RMK3 requires three rack spaces. To install the RMK3 into a standard 19" equipment rack:

1. Slide the rack mount kit onto the S86A chassis from the front as shown in Figure D-1.

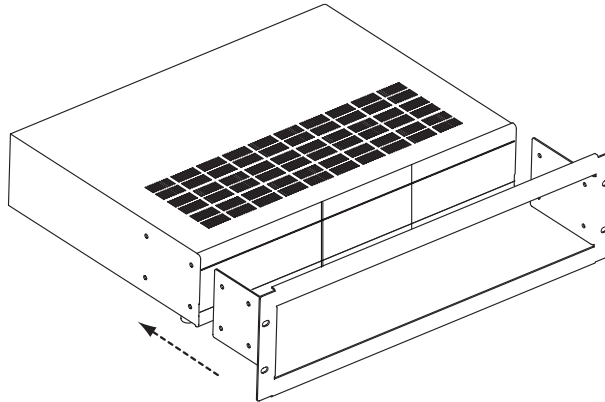

Figure: D-1

2. Ensure that the unit is flush with the front of the mounting kit. Install each of the eight screws (included) through the side mounting flanges into the holes in the sides of the unit as shown in Figure D-2. Hand tighten screws! Over-tightening could cause damage to the S86A Controller.

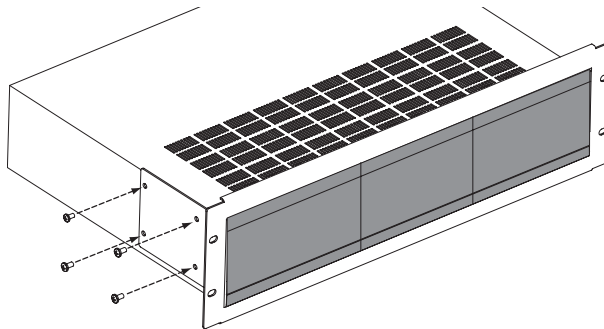

Figure: D-2.

3. Once the unit is securely mounted into the RMK3, install the entire assembly into a standard 19" equipment rack from the front using four rack screws (not included).

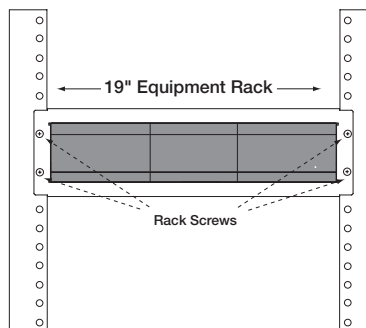

Figure: D-3.

Notes:

Notes:

Limited Warranty

ELAN HOME SYSTEMS L.L.C. ("ELAN") warrants the S86A Integrated Multi-Room A/V Controller to be free from defects in materials and workmanship for the period of two years (2 years) from date of purchase. If within the applicable warranty period above purchaser discovers that such item was not as warranted above and promptly notifies ELAN in writing, ELAN shall repair or replace the item at the company's option. This warranty shall not apply (a) to equipment not manufactured by ELAN, (b) to equipment which shall have been installed by other than an ELAN authorized installer, (c) to installed equipment which is not installed to ELAN's specifications, (d) to equipment which shall have been repaired or altered by others than ELAN, (e) to equipment which shall have been subjected to negligence, accident, or damage by circumstances beyond ELAN's control, including, but not limited to, lightning, flood, electrical surge, tornado, earthquake, or other catastrophic events beyond ELAN's control, or to improper operation, maintenance or storage, or to other than normal use of service. With respect to equipment sold by, but not manufactured by ELAN, the warranty obligations of ELAN shall in all respects conform to the warranty actually extended to ELAN by its supplier. The foregoing warranties do not cover reimbursement for labor, transportation, removal, installation or other expenses which may be incurred in connection with repair or replacement.

Except as may be expressly provided and authorized in writing by ELAN, ELAN shall not be subject to any other obligations or liabilities whatsoever with respect to equipment manufactured by ELAN or services rendered by ELAN.

THE FOREGOING WARRANTIES ARE EXCLUSIVE AND IN LIEU OF ALL OTHER EXPRESSED AND IMPLIED WARRANTIES EXCEPT WARRANTIES OF TITLE, INCLUDING BUT NOT LIMITED TO IMPLIED WARRANTIES OF MERCHANTABILITY AND FITNESS FOR A PARTICULAR PURPOSE.

ATTENTION: TO OUR VALUED CONSUMERS

To ensure that consumers obtain quality pre-sale and after-sale support and service, ELAN Home Systems products are sold exclusively through authorized dealers. ELAN products are not sold online. The warranties on ELAN products are NOT VALID if the products have been purchased from an unauthorized dealer or an online E-tailer. To determine if your ELAN reseller is authorized, please contact ELAN Home Systems at (859) 269-7760.
www.elanhomesystems.com



www.elanhomesystems.com
Lexington, KY