

S15

Two-Way Stage Speaker System

- PRO™ circuit provides HF driver protection
- Integral stand mount
- Constant-directivity 60° x 40° horn
- 250-watt long-term rms power capacity
- Roadworthy enclosure with metal corners, a metal grille and a durable black-carpet finish
- Dual 1/4-inch phone jack or dual Neutrik Speakon® inputs ¹

¹ See Connections section

Description

The Electro-Voice S15 is a 250-watt, two-way, high-efficiency, constant-directivity stage system featuring a vented, direct-radiating woofer section. It combines professional quality Electro-Voice components arranged in an unusually durable, light-weight enclosure. The result is wide-range accurate sound reproduction with transparent highs and extended bass response.

The high-frequency section of the S15 utilizes a 60° X 40° constant-directivity horn driven by a one-inch throat, wide-bandwidth, titanium-diaphragm driver. The DH2010A uses a unique, convex-drive Time Path™ phasing plug structure (U.S. Patent #4,525,604) for smooth and extended high-frequency performance. The voice coil is coupled to the diaphragm with EV's exclusive Resonant Drive™ Technology. This increases and smooths the high-frequency response and reduces the amount of internal equalization required for flat frequency response. Driver output extends to 20,000 Hz. A self-resetting high-frequency protection circuit, EV's PRO™ circuit, is included with the S15 to prevent against accidental over-drive and improve system reliability. If the

input power to the high-frequency driver exceeds the nominal rating, the protection circuit is activated and reduces the power delivered to the driver by 6 dB. The system will remain in this mode of operation until the input power is reduced to a safe level.

The bass section of the S15 is designed using Thiele-Small parameters for solid performance to 52 Hz. The 381-mm (15-in.) SG15 woofer used is a specially designed unit featuring an extended length voice coil and high-temperature construction materials. The system combines professional-quality components, arranged in an unusually durable Thiele-Small-aligned vented enclosure. The result is clear and articulate, high-quality sound.

Speaker Protection

The S15, like all other vented systems, experiences rapidly increasing cone excursion below the box-tuning frequency, while the acoustic output decreases rapidly. Therefore, to protect the S15 and maximize the power output of the system, it is necessary to insert an active 32- to 45-Hz high-pass filter into the circuit. The filter should have a slope of at least 12 dB per octave. Such subpassband filters are found in many crossovers and

equalizers manufactured by Electro-Voice, as well as other commercially available equipment.

Enclosure Construction

The S15 enclosure is constructed of Road-Wood™, a structural material that combines the strength of high-quality plywood with the density and acoustic damping of particle board without brittleness. Road-Wood™ uses the same principle of crossbanding veneers, as in plywood, in order to achieve its very high rigidity. A tough liquid-phenolic resin is blended with long, narrow strands of hard-wood. Alternate layers are perpendicularly bonded under intense heat and pressure to form panels of superior uniformity. Unlike many grades of plywood, Road-Wood™ is dimensionally stable, water-resistant and free from voids.

A combination of dado cut joints and tough adhesives ensure a sonically dead enclosure free from panel resonances.

The densely-woven, industrial-grade, abuse-resistant carpeting provides a finish that is both attractive and highly durable. Heavy-duty metal corner protectors, firmly secured rubber feet, recessed handles and a protective metal grille complete the picture and

S15 Two-Way Stage Speaker System

ensure that the S15 speaker system is ideally suited to a long and reliable life on the road.

Frequency Response

The combination of a 15-inch woofer, wide-bandwidth high-frequency driver and an equalized crossover results in the wide and smooth overall response shown in Figure 1. This response was measured at 3.05 meters (10 feet), using a 4-volt swept sine-wave input in an anechoic chamber. No external equalization was used. Figure 1 has been averaged and corrected for 1 watt at 1 meter.

Connections

The S15 is equipped with two parallel 1/4-inch phone jacks. (The S15-E has two parallel Neutrik Speakon® NL4MP connectors.) Another system can be connected in parallel by using the other connector. Care must be taken not to abuse the amplifier by connecting impedances which are too low.

Constant-Directivity Speaker System

The crossover frequency and speaker component geometries have been selected so that the directional characteristics of the woofer and constant-directivity horn match at the crossover frequency to create a special system type — the constant-directivity system. At higher frequencies the horizontal coverage pattern remains constant and the vertical pattern smoothly transitions to a 40° angle above 5,000 Hz. Response within the 60°x 40° rated coverage angle is uniform, which means dependable audience coverage without “hot spots” or dead zones at certain frequencies. The 60° x 40° dispersion characteristic also helps avoid early reflections from nearby floor or side-wall surfaces which could degrade performance. The controlled directivity of the high- and low-frequency transducers also eliminates response irregularities caused by diffraction off nearby enclosure edges and, in combination with an essentially flat on-axis frequency response, produces a total acoustic power output that is uniform with frequency.

Directivity

A unique feature of the S15 is the constant-directivity dispersion provided by the 60° x 40° horn. The polar response of the system at selected one-third-octave bandwidths is shown in Figure 5. These polar responses were measured in an anechoic environment at 6.1 meters (20 feet) using one-third-octave pink-noise inputs. The frequencies selected are fully representative of the polar response of the system. Beamwidth of the system utilizing the complete one-third-octave polar data is shown in Figure 6. Directivity factor, R_θ , and directivity index, D_i , are plotted in Figure 7.

Power-Handling Capacity

Electro-Voice components and systems are manufactured to exacting standards, ensuring they will hold up, not only through the most rigorous of power tests, but also through continued use in arduous, real-life conditions. The EIA Loudspeaker Power Rating Full Range (ANSI/EIA RS-426-A 1980) uses a noise spectrum which mimics typical music and tests the thermal and mechanical capabilities of the components. Electro-Voice will support relevant additional standards as and when they become available. Extreme, in-house power tests, which push the performance boundaries of the woofers, are also performed and passed to ensure years of trouble-free service.

Specifically, the S15 passes ANSI/EIA RS-426-A 1980 with the following values:

$$R_{SR} = 5.98 \text{ ohms } (1.15 \times R_E)$$

$$P_{E(MAX)} = 250 \text{ watts}$$

$$\text{Test voltage} = 38.67 \text{ volts rms,}$$

$$77.33 \text{ volts peak (+6dB)}$$

The “peak” power-handling capacity of a woofer is determined by the peak test voltage amount. For the S15, a 77.33-volt peak test voltage translates into 1,000-watts short-term peak power-handling capacity. This is the equivalent of four times the “average” power-handling capacity, and is a peak that can be sustained for only a few milliseconds. However, this sort of short-duration peak is very typical in speech and music. Provided the amplifier can reproduce the signal accu-

rately, without clipping, the system will perform accurately and reliably, even at these levels.

Amplifier Power Recommendations

As noted in the Power-Handling Capacity section, above, the S15 has a random-noise power capacity of 250 watts long term (1,000 watts peak) per ANSI/EIA RS-426-A 1980. The following guidelines will help relate this to an appropriate power amplifier output rating.

1. To use the S15 to full capacity, skilled experts in sound system installation and operation will obtain the best results if the power amplifier is 2.0 to 4.0 times the long-term average noise power rating of the speaker system. For the S15 this is 500 to 1,000 watts.
The caution cannot be made strongly enough, however, that this arrangement is only for experts or those who can discipline themselves against “pushing” the system for ever-higher sound levels and who can avoid “accidents” such as catastrophic feedback or dropped microphones.
2. A more conservative, “normal” amplifier size, which will produce audible results nearly equal to those of the “expert” recommendation, is 1.0 to 1.4 times the long-term average noise power rating of the speaker. For the S15 this is 250 to 350 watts.
3. To be very conservative, one can use an amplifier rated at 0.5 to 0.7 times the long-term average noise power rating of the loudspeaker. For the S15 this is 125 to 175 watts.

Request P.A. Bible Addition No. Two (“Power Handling Capacity”) for more background on these recommendations.

Service

In the unlikely event the S15 requires service, the woofer and driver can both be replaced or serviced from the front. A service data sheet is available from Electro-Voice.

S15 Two-Way Stage Speaker System

Stand Mounting

The S15 can be mounted on the 100 BK speaker stand, or any other stand with a 1-3/8-inch diameter shaft.

Architects' and Engineers' Specifications

The loudspeaker shall be a compact vented-box type. The low frequencies shall be reproduced with one 250-watt (ANSI/EIA RS-426-A 1980) SG15 381-mm (15-in.) vented woofer, and a DH2010A high-frequency compression driver mounted on a 60° x 40° constant-directivity horn. The system will reproduce the frequencies from 52 to 20,000 Hz. The system shall be capable of producing average sound levels in excess of 123 dB in the long term, and short-term peaks of 129 dB.

The enclosure shall be constructed of black-carpeted Road-Wood™ and have a metal grille which attaches with 7 screws. The dimensions shall be 778 mm (30.7 in.) tall, 505 mm (19.8 in.) wide, and 403 mm (15.9 in.) deep. The system shall weigh 24.5 kg (54 lb). Two parallel 1/4-inch phone jack connections shall be provided. (Two Neutrik Speakon® connections shall be provided on the "E" version.)

The loudspeaker system shall be the Electro-Voice S15 (or S15-E).

Uniform Limited Warranty

Electro-Voice products are guaranteed against malfunction due to defects in mate-

rials or workmanship for a specified period, as noted in the individual product-line statement(s) below, or in the individual product data sheet or owner's manual, beginning with the date of original purchase. If such malfunction occurs during the specified period, the product will be repaired or replaced (at our option) without charge. The product will be returned to the customer prepaid.

Exclusions and Limitations: The Limited Warranty does not apply to: (a) exterior finish or appearance; (b) certain specific items described in the individual product-line statement(s) below, or in the individual product data sheet or owner's manual; (c) malfunction resulting from use or operation of the product other than as specified in the product data sheet or owner's manual; (d) malfunction resulting from misuse or abuse of the product; or (e) malfunction occurring at any time after repairs have been made to the product by anyone other than Mark IV Audio Service or any of its authorized service representatives. **Obtaining Warranty Service:** To obtain warranty service, a customer must deliver the product, prepaid, to Mark IV Audio Service or any of its authorized service representatives together with proof of purchase of the product in the form of a bill of sale or receipted invoice. A list of authorized service representatives is available from Mark IV Audio Service at 600 Cecil Street, Buchanan, MI 49107 (800/234/6831 or FAX 616/695/4743). **Incidental and Consequential Damages Excluded:** Product repair or replacement and return to

the customer are the only remedies provided to the customer. Electro-Voice shall not be liable for any incidental or consequential damages including, without limitation, injury to persons or property or loss of use. Some states do not allow the exclusion or limitation of incidental or consequential damages so the above limitation or exclusion may not apply to you. **Other Rights:** This warranty gives you specific legal rights, and you may also have other rights which vary from state to state.

Electro-Voice Speakers and Speaker Systems are guaranteed against malfunction due to defects in materials or workmanship for a period of five (5) years from the date of original purchase. The Limited Warranty does not apply to burned voice coils or malfunctions such as cone and/or coil damage resulting from improperly designed enclosures. Electro-Voice active electronics associated with the speaker systems are guaranteed for three (3) years from the date of original purchase. Additional details are included in the Uniform Limited Warranty statement.

For warranty repair, service information, or a listing of the repair facilities nearest you, contact the service repair department at: 616/695-6831 or 800/685-2606.

For technical assistance, contact Technical Support at 800/234-6831 or 616/695-6831, M-F, 8:00 a.m. to 5:00 p.m. eastern standard time.

Specifications subject to change without notice.

Figure 1—Axial Frequency Response, (anechoic environment, 4 volts/3.05 meters (10 feet), normalized to 1 watt/1 meter)

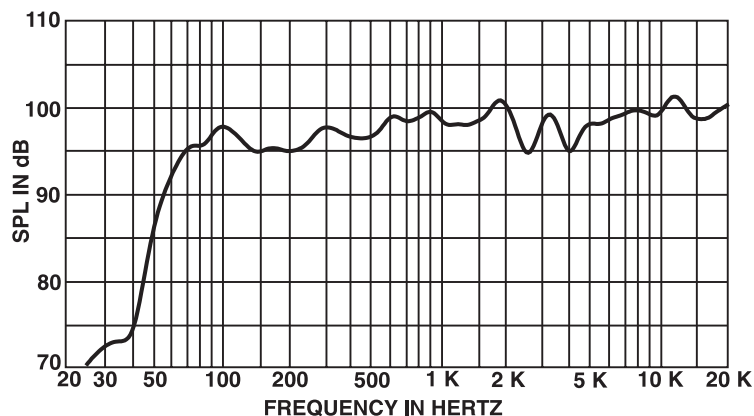

S15 Two-Way Stage Speaker System

Figure 2—Harmonic Distortion Response 10% Rated Power Input (25 watts), (anechoic environment, 3.05 meters (10 feet) on axis)

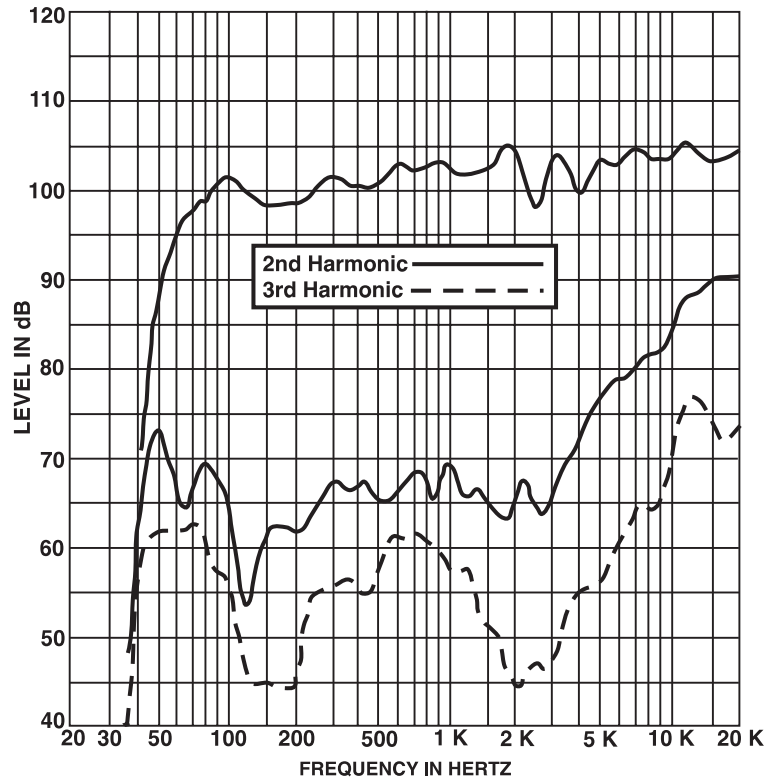

S15 Two-Way Stage Speaker System

Figure 3—Impedance Curve

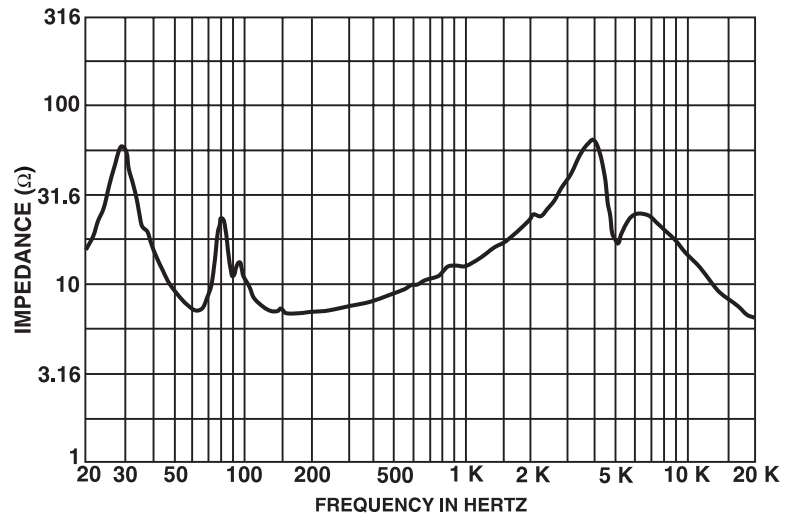
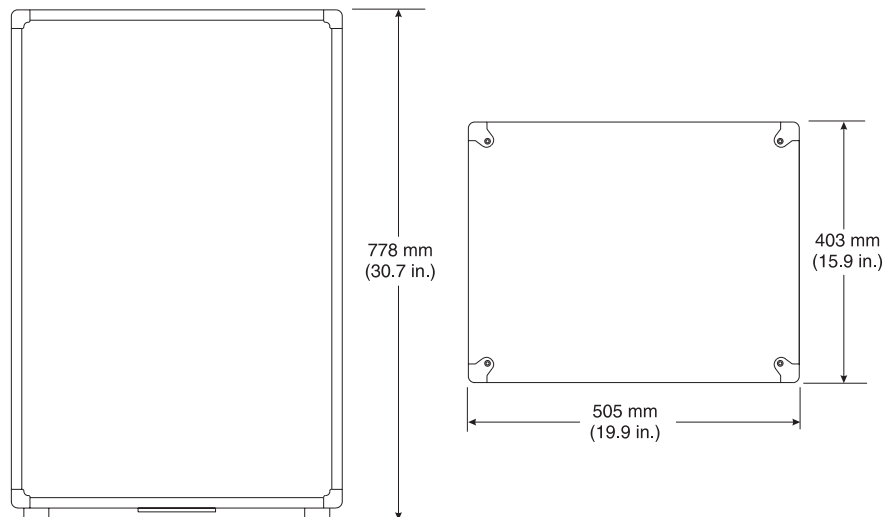

Figure 4—Dimension Line Drawing



S15 Two-Way Stage Speaker System

Figure 5—One-Third-Octave Polar Responses (anechoic environment, 4 volts/6.10 meters (20 feet))

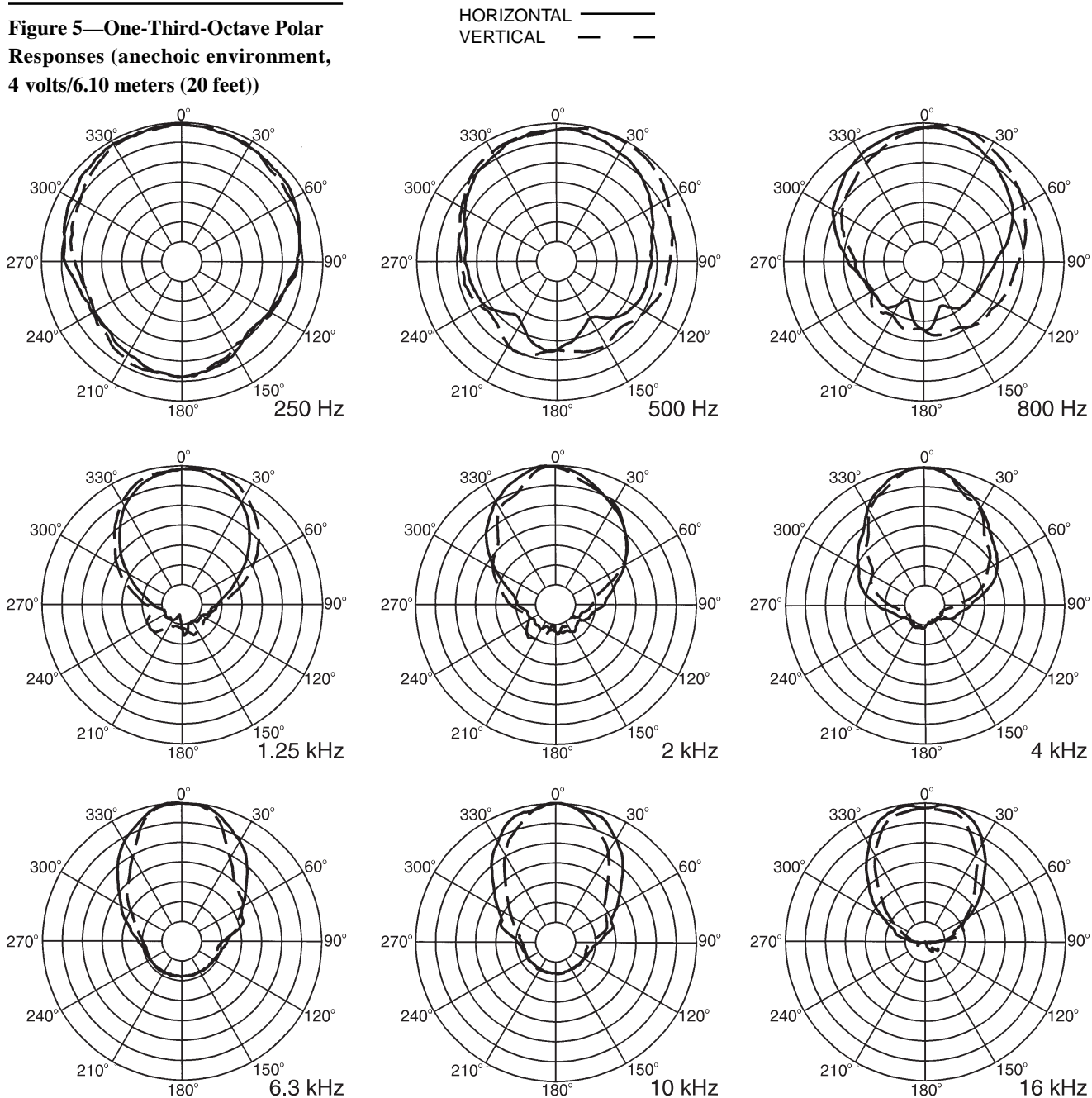
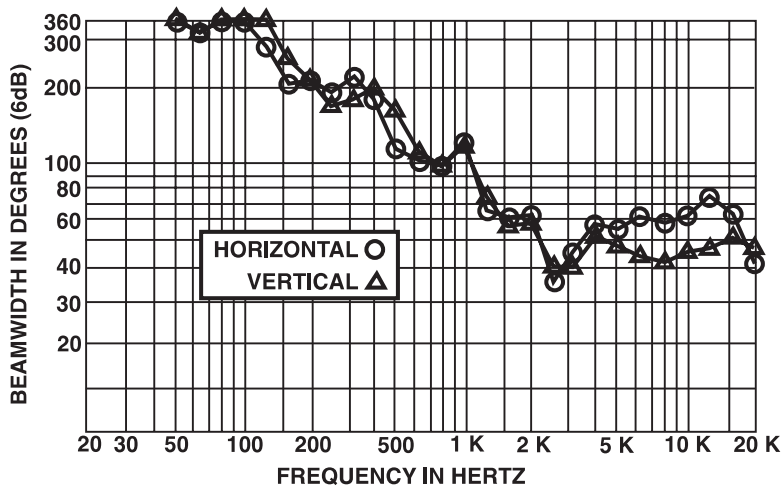
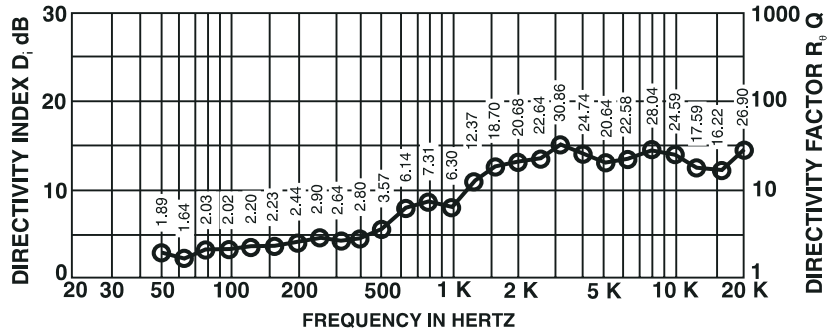

Figure 6—Beamwidth vs. Frequency (anechoic environment)



S15 Two-Way Stage Speaker System

Figure 7—Directivity vs. Frequency
(anechoic environment)



S15 Two-Way Stage Speaker System

Specifications

Typical Axial Frequency Response, Swept Sine Wave, 4 volts at 3.05 meters (10 feet), (anechoic environment, normalized for 1 watt at 1 meter; see Figure 1):

67-20,000 Hz

Low-Frequency 3-dB-Down Point:

67 Hz

Usable Low-Frequency Limit (10-dB-down point):

52 Hz

Efficiency:

3.3%

Long-Term Average Power-Handling Capacity per EIA Standard RS-426A (see Power-Handling section):

250 watts

Maximum Woofer Acoustic Output:

8.3 watts

Sensitivity (SPL at 1 watt, 1 meter Input, Anechoic Environment, Swept Sine Wave):

99 dB

Dispersion Angle Included by 6-dB-Down Points on Polar Responses, Indicated One-Third-Octave Bands of Pink Noise (see Figure 6),

2,500-20,000 Hz, Horizontal:

60° (+14°, -25°)

2,500-20,000 Hz, Vertical:

40° (+12°, -0°)

Directivity Factor R_0 (Q), 800- to 16,000-Hz Median (see Figure 7):

19.5 (+11.4, -13.2)

Directivity Index D_i , 800- to 16,000-Hz Median (see Figure 7):

12.9dB (+2.0dB, -4.9 dB)

Distortion, 0.1 Full Power Input, (see Figure 2)

Second Harmonic,

100 Hz:

-36 dB, 1.5%

1,000 Hz:

-33 dB, 2.2%

10,000 Hz:

-20 dB, 10%

Third Harmonic,

100 Hz:

-45 dB, 0.6%

1,000 Hz:

-45 dB, 0.6%

10,000 Hz:

-35 dB, 1.8%

Transducer Complement,

Low-Frequency:

SG15 15-inch woofer

High Frequency:

DH2010A driver

HP64M constant-directivity horn

Box Tuning Frequency:

62 Hz

Crossover Frequency:

2,900 Hz

Crossover Slope:

12 dB per octave

Impedance,

Nominal:

8 ohms

Minimum:

6.9 ohms

Input Connections:

Two parallel 1/4-inch phone jacks
(Two parallel Neutrik Speakon®
NL4MP connectors on S15-E)

Enclosure Materials and Colors:

Black-carpeted Road-Wood™

Black perforated metal grille

Dimensions (see Figure 4)

Height:

778 mm (30.7 in.)

Width:

505 mm (19.9 in.)

Depth:

403 mm (15.9 in.)

Net Weight:

24.5 kg (54 lb)

Shipping Weight:

28.1 kg (62 lb)

Optional Accessory:

100BK mounting stand

Electro-Voice®

a MARK IV company

600 Cecil Street, Buchanan, MI 49107