

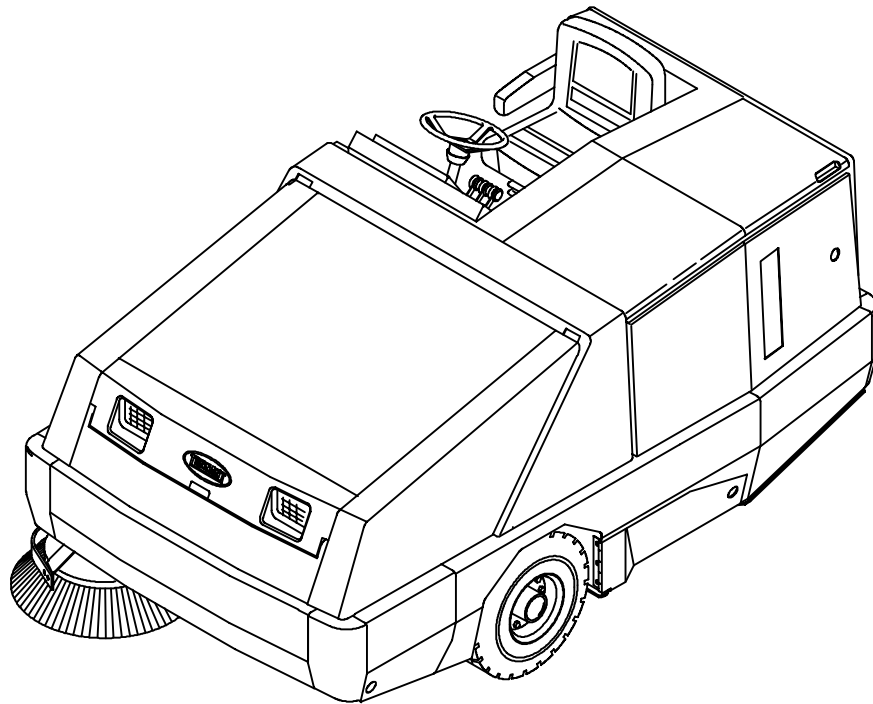

800D

Parts Manual



MM308



This manual is furnished with each new TENNANT Model 800D.

This manual consists of the How To Use This Manual; Standard Parts; Options; Breakdowns; Engine Breakdown; and Cross Reference sections.

MACHINE DATA

Please fill out at time of installation for future reference.

Machine Model number – 800D

Machine Serial number – _____

Machine Options – _____

TE A T Representative/phone no – _____

Customer ID number – _____

Date of Installation – _____

Manual number – MM308

Revision 07

Published 11–95

HOW TO USE THIS MANUAL

This section on *HOW TO USE THIS MANUAL* will tell you how to:

- Find important machine information for ordering correct repair parts.
- Find TENNANT part numbers.
- Order TENNANT parts and supplies.

IMPORTANT INFORMATION

When placing an order for parts, the machine model and machine serial number are important. Refer to the *MACHINE DATA* box which is filled out during the installation of your machine. The *MACHINE DATA* box is located on the inside of the front cover of this manual.

MACHINE DATA	
<i>Please fill out at time of installation for future reference.</i>	
Machine Model Number -	800D
Machine Serial Number -	_____
Machine Options -	_____
TENNANT Representative/phone no. -	_____
Customer ID Number -	_____
Date of Installation -	_____
Manual Number -	MM308
Revision:	00
Published:	1-93

The model number of your machine is on the side of the machine.

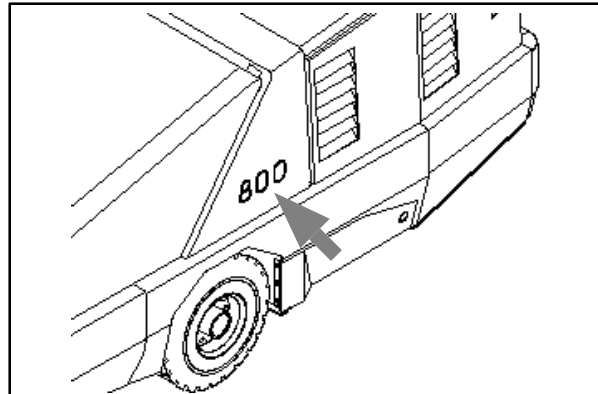

The serial number of your machine is printed on the machine data plate located as shown.

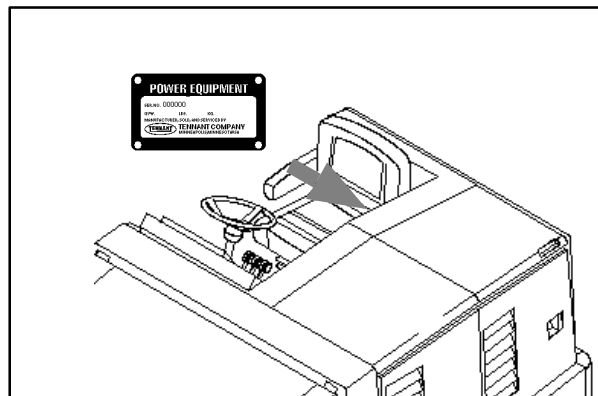

HOW TO USE THIS MANUAL

FINDING A TENNANT PART NUMBER

This manual contains the following sections:

- HOW TO USE THIS MANUAL
- STANDARD PARTS
- OPTIONS
- BREAKDOWNS
- CROSS REFERENCE

The STANDARD PARTS section lists repair parts for standard machines. They are grouped in this general order:

- General wear parts.
- Machine frame and related parts.
- Machine propelling system.
- Scrubbing components.
- Electrical parts.

The OPTION section lists repair parts of options.

The BREAKDOWN section lists available repair parts of major components.

All sections in this manual consist of parts illustrations and corresponding parts lists.

The parts illustrations are numbered with **Ref** numbers which refer to corresponding parts lists.

The parts lists include a number of columns of information:

- **Ref** – column refers to the reference number on the parts illustration.
- ▽ – indicates the part is an assembly.
- indicates the part is included in the assembly listed just before it.
- **TENNANT Part No.** – column lists the TENNANT part number for the part.
- **Serial Number** – column indicates the set of machines the part number is applicable to. Serial numbers change when the machine design has been modified. The most current design of the machine is shown in the main illustration, older designs are boxed in a corner of the illustration.
- **Description** – column is a brief description of the part.
- **Qty.** – column lists the quantity of that part used in that area of the machine.

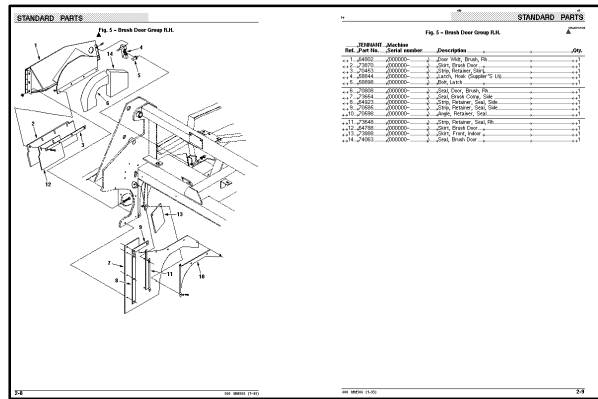

Ref.	Part No.	Serial number	Description	Qty.
1	59970	000000	Replm Kit, Instr Panel	1
1	59976	000000	Replm Kit, Case	1
2	59977	000000	Replm Kit, Seal	1
3	59974	000000	Replm Kit, Cir Board	1
4	59978	000000	Replm Kit, Hourmeter	1
5	59979	000000	Replm Kit, Touch Panel	1
6	59971	000000	Replm Kit, Lamp, Backlighting (C)	2
7	65346	000000	Replm Kit, Lamp (S)	1
8	10632-5	000000	Grommet, Rbr, 0.25Id, For .09Matl.	4
9	61969	000000	Switch, Rocker, Dpst	1
10	57807	000000	Cover, Rocker Switch Seal	1
11	87536	000000	Switch Ignition	1
12	87866	000000	Key Set, Switch Ku	1
13	72109	000000	Replm Kit, Sun Shield	1
14	65245	000000	Panel, Cover, Dash	1
15	70637	000000	Seal, Handle, Valve	1

NOTE: If a service kit is installed on your machine, be sure to keep the **INSTRUCTION BULLETIN** which came with the kit. It contains repair parts numbers needed for ordering future parts.

NOTE: Fasteners used in this machine may be metric or non-metric. Take care when replacing hardware to replace with same thread size.

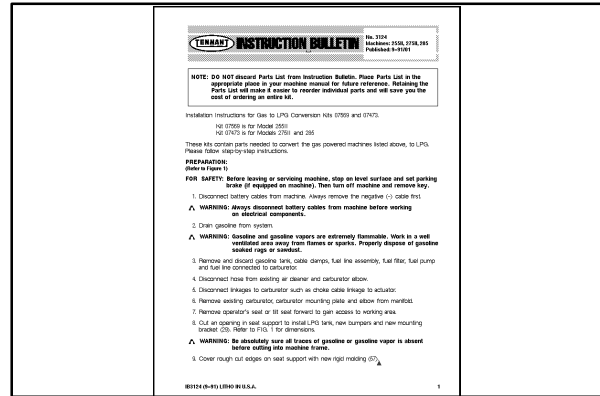

PLACING AN ORDER

Orders may be placed by phone, fax, or by mail. Phone orders may need written confirmation. Follow the steps below to insure prompt delivery:

1. Identify the model number of your machine.
2. Identify the serial number of your machine.
3. Find the part number of the part you need. Do not order by page number or reference number. If you are not able to find the part number, call your TENNANT representative for help or send the old part as a sample.
4. Determine the quantity of the part you need.
5. Provide the following company information:
 - Company name
 - Customer ID Number
 - Shipping address
 - Billing address
 - First and last name of person ordering parts
 - Telephone number
 - Purchase order number
6. Provide definitive shipping instructions.

HOW TO USE THIS MANUAL

Any claim for loss or damage to a shipment in transit should be filed promptly with the transportation company making the delivery. Shipments will be complete unless the packing list or order acknowledgement indicates items back ordered.

If parts received are suspected to be incorrect or defective, please contact the TENNANT representative from whom you ordered the part. They will give authorization for return and/or handle replacement shipments when required.

SECTION 2

CONTENTS

	PAGE
Fig. 1 – Recommended General Maintenance Items	2-3
Fig. 2 – Replacement Brushes	2-4
Fig. 3 – Main Frame, Skirt and Seals Group	2-6
Fig. 4 – Main Frame, Skirt and Seals Group	2-8
Fig. 5 – Left Brush Door Group	2-10
Fig. 6 – Right Brush Door Group	2-12
Fig. 7 – Operator Station Group	2-14
Fig. 8 – Operator Station Group	2-16
Fig. 9 – Engine Cover and Lintel Group	2-18
Fig. 10 – Engine Cover and Lintel Group	2-20
Fig. 11 – Engine Side Door Group	2-22
Fig. 12 – Engine Side Door Group	2-24
Fig. 13 – Grille and Hydraulic Cooler Group	2-26
Fig. 14 – Hopper Lift Arms Group	2-28
Fig. 15 – Hopper Lift Arms Group	2-30
Fig. 16 – Hopper Lift Cylinders Group	2-32
Fig. 17 – Hopper Lift Cylinders Group	2-34
Fig. 18 – Hopper Group	2-36
Fig. 19 – Hopper Group	2-38
Fig. 20 – Hopper Door Group	2-40
Fig. 21 – Hopper Door Group	2-42
Fig. 22 – Hopper Cover Group	2-44
Fig. 23 – Hopper Cover Group	2-46
Fig. 24 – Hopper Bumper Group	2-48
Fig. 25 – Hopper Bumper Group	2-50
Fig. 26 – Filter Shaker Group	2-52
Fig. 27 – Pressure Switch Group	2-54
Fig. 28 – Engine and Mount Group	2-56
Fig. 29 – Engine and Mount Group	2-58
Fig. 30 – Alternator Group	2-60
Fig. 31 – Air Cleaner Group	2-62
Fig. 32 – Air Cleaner Group	2-64
Fig. 33 – Muffler Group	2-66
Fig. 34 – Fuel Tank Group	2-68
Fig. 35 – Fuel Tank Group	2-70
Fig. 36 – Radiator Hose Group	2-72
Fig. 37 – Radiator Group	2-74
Fig. 38 – Radiator Group	2-76
Fig. 39 – Cooling Fan and Housing Group	2-78
Fig. 40 – Cooling Fan and Housing Group	2-80
Fig. 41 – Battery Group	2-82
Fig. 42 – Battery Group	2-84
Fig. 43 – Rear Wheel Drive Group	2-86
Fig. 44 – Front Wheels and Brakes Group	2-88
Fig. 45 – Wheel Assembly	2-90
Fig. 46 – Brake Pedals Group	2-92
Fig. 47 – Directional Pedal Group	2-94
Fig. 48 – Hydraulic Pumps Group	2-96

Continued

CONTENTS

	PAGE
Fig. 49 – Hydraulic Schematic (for machines below serial number xxxxxx)	2-98
Fig. 50 – Hydraulic Schematic (for machines serial number xxxxxx and above)	2-99
Fig. 51 – Hydraulic Hose Group (for machines below serial number xxxxxx)	2-100
Fig. 52 – Hydraulic Hose Group (for machines serial number xxxxxx and above)	2-102
Fig. 53 – Hydraulic Reservoir Group	2-104
Fig. 54 – Hydraulic Solenoid Valve Group	2-106
Fig. 55 – Hydraulic Lift Valve Group	2-108
Fig. 56 – Hydraulic Lift Valve Group	2-110
Fig. 57 – Side Brush Group	2-112
Fig. 58 – Side Brush Lift Group	2-114
Fig. 59 – Side Brush Lift Group	2-116
Fig. 60 – Main Brush Drive Group	2-118
Fig. 61 – Main Brush Lift Group	2-120
Fig. 62 – Main Brush Adjustment Group	2-122
Fig. 63 – Main Brush Adjustment Group	2-124
Fig. 64 – Vacuum Fan Impeller Group	2-126
Fig. 65 – Vacuum Fan Impeller Group	2-128
Fig. 66 – Vacuum Fan Motor Group	2-130
Fig. 67 – Steering Group	2-132
Fig. 68 – Instrument Panel Assembly	2-134
Fig. 69 – Circuit Breaker and Relay Group	2-136
Fig. 70 – Electrical Schematic	2-138
Fig. 71 – Wire Harnesses Group	2-142
Fig. 72 – Label Group	2-149

Fig. 1 – Recommended General Maintenance Items

Ref.	Tenant Part No.	Machine Serial Number	Description	Qty.
∇	77632	(000000–)	Maintenance Kit, Skirts	1
	73870	(000000–)	Skirt, Brush Door	2
	64788	(000000–)	Skirt, Brush Door	2
	70453	(000000–)	Strip, Retainer, Skirt	2
	62955	(000000–)	Skirt, Seal, Main Brush	1
	62957	(000000–)	Channel, Retainer, Seal, Rear	1
	62954	(000000–)	Blade, Deflector	1
	62956	(000000–)	Strap, Retainer, Seal	1
	43500	(000000–)	Chain, Link#2/0, 7Links	1
∇	79032	(000000–)	Maintenance Kit, Skirts 800	1
	64919	(000000–)	Seal, Pan, Top	1
	64920	(000000–)	Channel, Retainer	1
	73654	(000000–)	Seal, Brush Comp, Side	2
	73888	(000000–)	Skirt, Front, Indoor	2
∇	77633	(000000–)	Maintenance Kit, 400HR 800/810 Diesel	1
	01433–1	(000000–)	Grease, Lubriplt EMB 14.5OZ	1
	74863	(000000–)	Filter, Oil PK TFYO–14–302	4
	74858	(000000–)	Filter, Fuel PK TFO1–13–ZA5	1
∇	77634	(000000–)	Maintenance Kit, 800HR 800/810	1
	34306	(000000–)	Breather, Hyd 40Mic No DS	1
	31613	(000000–)	Strainer–Hyd Suction 25–100–03	1
	10664	(000000–)	Filter Assy, Spin–on	1
	65869–5	(000000–)	Fluid, Hyd Oil, SHP 15/40 5Gal	3

Fig. 2 – Replacement Brushes

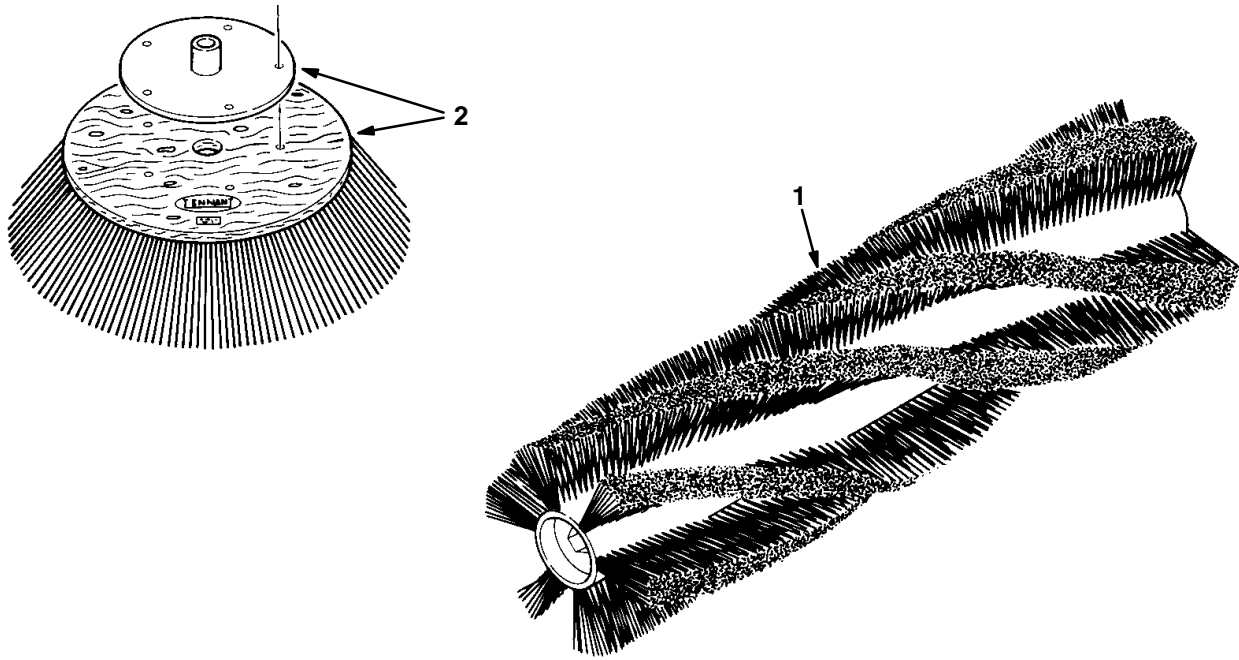

Fig. 2 – Replacement Brushes

1 370011..... BRUSH, SWP, 50L, WEDGE, PYP ,SPL 1

Ref.	Tennant Part No.	Machine Serial Number	Description	Qty.	
1	35326	(000000–)	Brush–Sweep Spl–50Lg – 8Dr–Poly	1	
1	35324	(000000–)	Brush–Sweep Spl–50Lg–8Dr–P&W	1	
1	35327	(000000–)	Brush–Sweep Spl–50Lg–8Dr–Wire	1	
1	35325	(000000–)	Brush–Outsd Spl–50Lg – 8Dr–Poly	1	
1	35336	(000000–)	Brush–Patrl Spl–50Lg – 4Qr–Nyl	1	
	1	35323	(000000–)	Brush–Sweep Spl–50Lg–24Sr–Nyl	1
∇	2	75011	(000000–)	Brush–Side Swp –26 D–Assy–Nyl	1
		51021N	(000000–)	Brush–Side Swp –26 D–Nyl	1
		51963	(000000–)	Adaptor Weldm., Side Brush 1.0B	1
∇	2	75010	(000000–)	Brush–Side Swp –26 D–Assy–Fltw	1
		51542	(000000–)	Brush–Side Swp –26 D–Fltw	1
		51963	(000000–)	Adaptor Weldm., Side Brush 1.0B	1
∇	2	70649	(000000–)	Brush–Side Swp –26 D–Assy–Poly	1
		70538	(000000–)	Brush–Side Swp –26 D–Poly	1
		51963	(000000–)	Adaptor Weldm., Side Brush 1.0B	1

Fig. 3 – Main Frame, Skirt and Seals Group

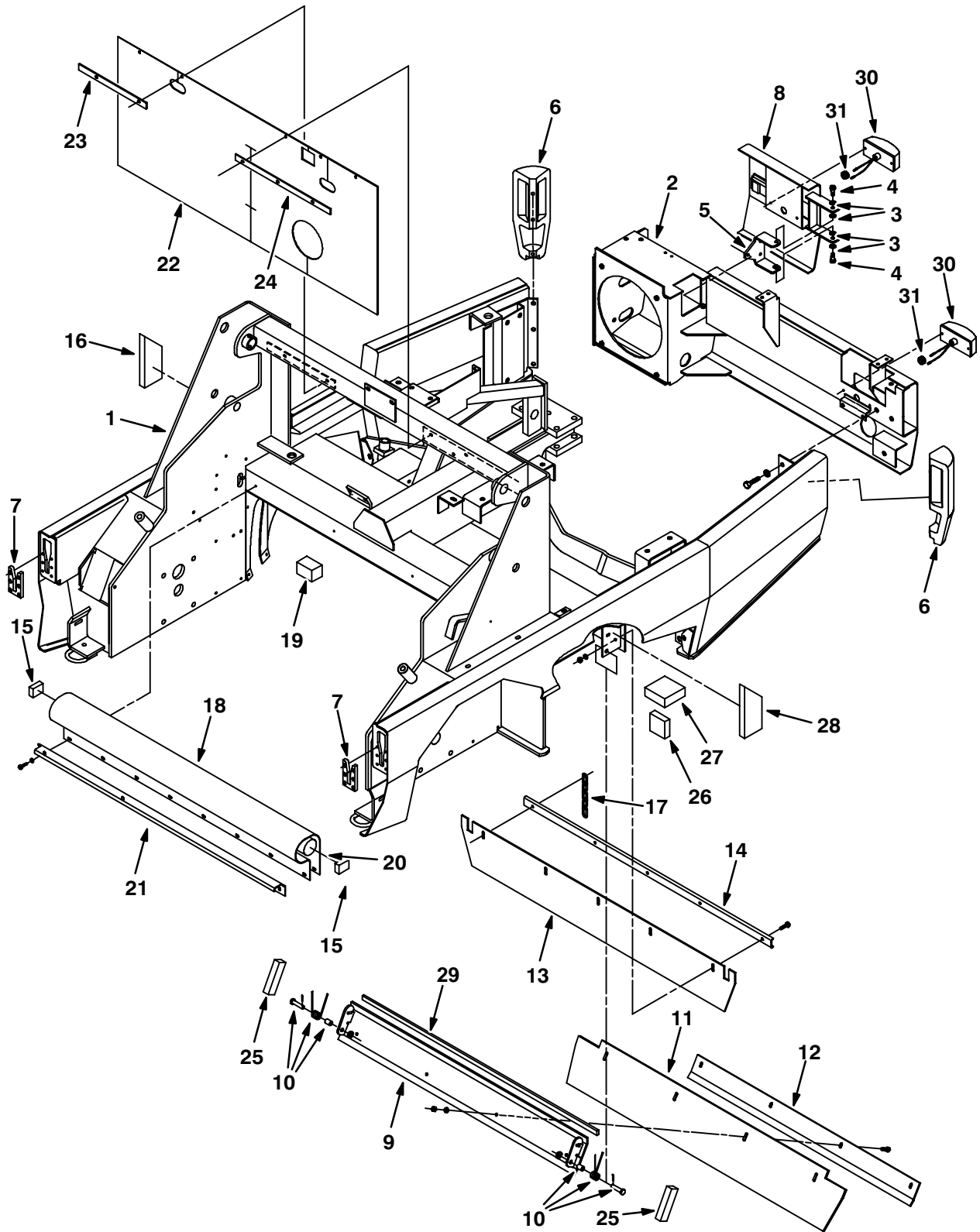

Fig. 3 – Main Frame, Skirt and Seals Group

Ref.	Tennant Part No.	Machine Serial Number	Description	Qty.
1	62960	(000000-001131)	Frame Wldt	1
2	70451	(000000-001223)	Bumper Wldt, Rear	1
3	86860	(000000-001223)	Bearing, Thrust .500	4
4	36758	(000000-001223)	Scr-Shld .500Dx0.50L .38-16	2
5	70517	(000000-001223)	Bracket	1
6	63544	(000000-001223)	Bumper, Corner, Mach	2
7	63663	(000000-001223)	Plate, Guide, Bumper	2
8	70498	(000000-001223)	Door Wldt	1
9	73645	(000000-001223)	Channel Wldt, Mtg	1
10	69904	(000000-001223)	Spring Assy, Recirculation	2
11	62954	(000000-001223)	Blade, Deflector	1
12	62956	(000000-001223)	Strap, Retainer, Seal	1
13	62955	(000000-001223)	Skirt, Seal, Main Brush	1
14	62957	(000000-001223)	Channel, Retainer, Seal, Rear	1
15	82125	(000000-001223)	Seal, Foam Rbr .75 1.5W 2.1L	2
16	74066	(000000-001223)	Seal, Foam	1
17	43500	(000000-001223)	Chain,Link#2/0,7Links	1
18	64919	(000000-001223)	Seal, Pan, Top	1
19	73722	(000000-001223)	Seal, Main Brush	2
20	34690	(000000-001223)	Sponge Cord 1.5Dia	1
21	64920	(000000-001223)	Channel, Retainer	1
22	73724	(000000-001223)	Shield, Dust	1
23	70843	(000000-001223)	Strip, Retainer, Shield, Rh	1
24	70844	(000000-001223)	Strip, Retainer, Shield, Lh	1
25	74064	(000000-001223)	Seal, Foam	2
26	73863	(000000-001223)	Insulation,S/Foam1.0X 3.0X 3.0	2
27	73862	(000000-001223)	Insulation,S/Foam1.5X 4.0X 4.0	2
28	74067	(000000-001223)	Seal, Foam	1
29	74038	(000000-001223)	Seal, Foam	1
∇ 30	57941	(000000-001223)	Light Assy Stop/Red 12V- A	2
	45780	(000000-001223)	Bulb, 12V .5A 4CP#1157	1
31	87515	(000000-001223)	Grommet, Rbr, .50 ID, For .25 Matl	2

Fig. 4 – Main Frame, Skirt and Seals Group

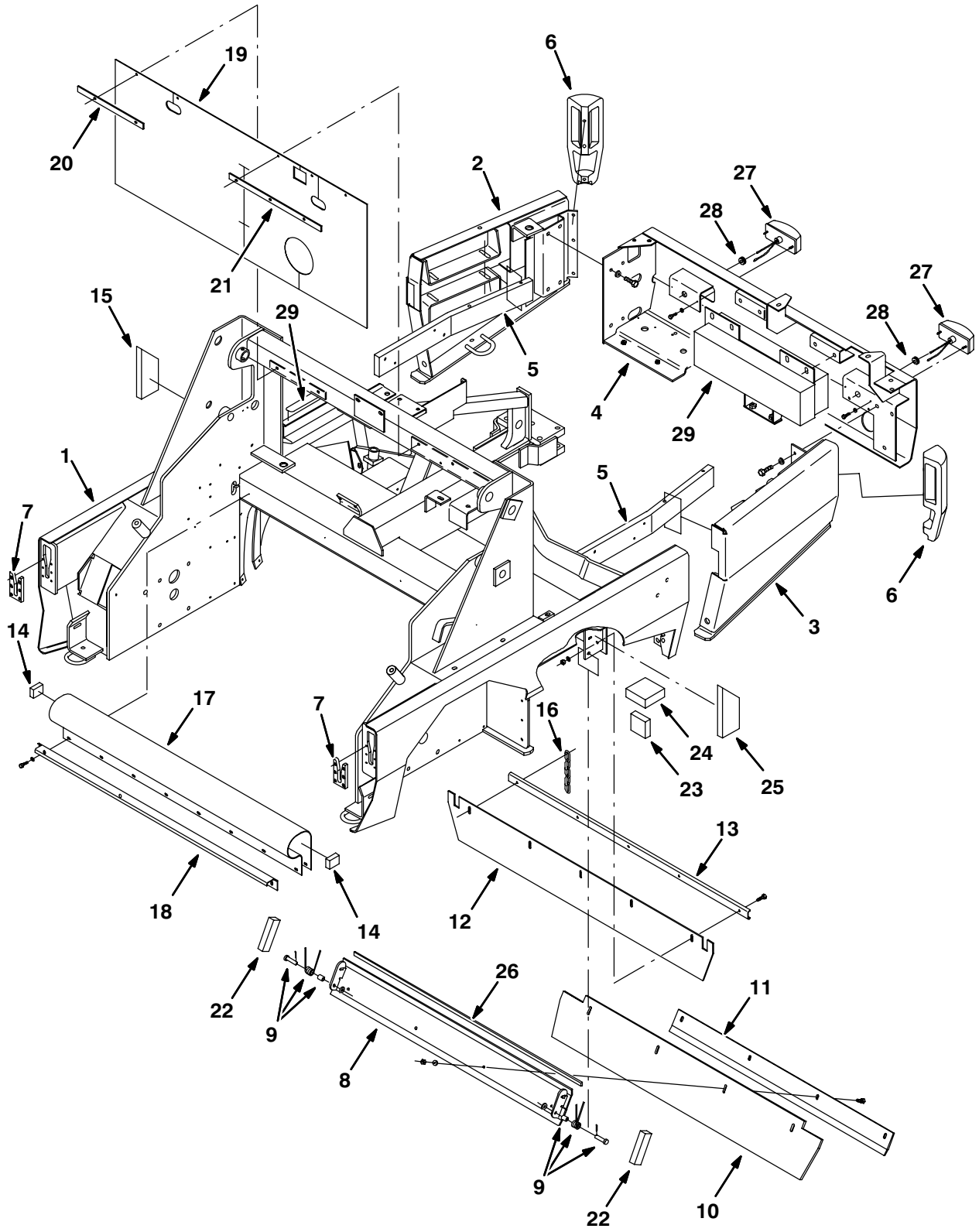

Fig. 4 – Main Frame, Skirt and Seals Group

Ref.	Tennant Part No.	Machine Serial Number	Description	Qty.
1	76555	(001132-001223)	Frame	1
1	77777	(001224-)	Frame	1
2	76464	(001132-001223)	Panel Wldt, Rear, Rh	1
2	77782	(001224-)	Panel Wldt, Rear, Rh	1
3	76465	(001132-001223)	Panel Wldt, Rear, Lh	1
3	77734	(001224-)	Panel Wldt, Rear, Lh	1
4	22024	(001224-001302)	Replacement Kit, Bumper, Die	1
4	79680	(001303-)	BumperWldt, Rear, (Gas/Die)	1
5	77593	(001224-)	Bar, Frame	2
6	63544	(001224-)	Bumper, Corner, Mach	2
7	63663	(001224-)	Plate, Guide, Bumper	2
8	73645	(001224-)	Channel, Mounting	1
9	69904	(001224-)	Spring, Recirculation	1
10	62954	(001224-)	Blade, Deflector	1
11	62956	(001224-)	Strap, Retainer, Seal	1
12	62955	(001224-)	Skirt, Seal, Main Brush	1
13	62957	(001224-)	Channel, Retainer, Seal,Rear	1
14	82125	(001224-)	Seal Foam Rbr .75 1.5W 2.1L	2
15	74066	(001224-)	Insulation, S/Foam	1
16	43500	(001224-)	Chain,Link#2/0,7Links	1
17	64919	(001224-)	Seal, Pan, Top	1
18	64920	(001224-)	Channel, Retainer	1
19	73724	(001224-)	Shield, Dust	1
20	70843	(001224-)	Strip, Retainer, Shield, Rh	1
21	70844	(001224-)	Strip, Retainer, Shield, Lh	1
22	74064	(001224-)	Insulation, S/Foam	2
23	73863	(001224-)	Insulation, S/Foam 1.0X3.0X3.0	2
24	73862	(001224-)	Insulation, S/Foam 1.5X4.0X4.0	2
25	74067	(001224-)	Insulation, S/Foam	1
26	79010	(001224-)	Seal	1
∇ 27	57941	(001224-)	Light Assy Stop/Red 12V- . A	2
	45780	(001224-)	Bulb, 12V .5A 4Cp #1157	1
28	87515	(001224-)	Grommet,Rbr,0.50ld,For .25Matl	2
29	79676	(001303-)	Weight, Die	1

Fig. 5 – Left Brush Door Group

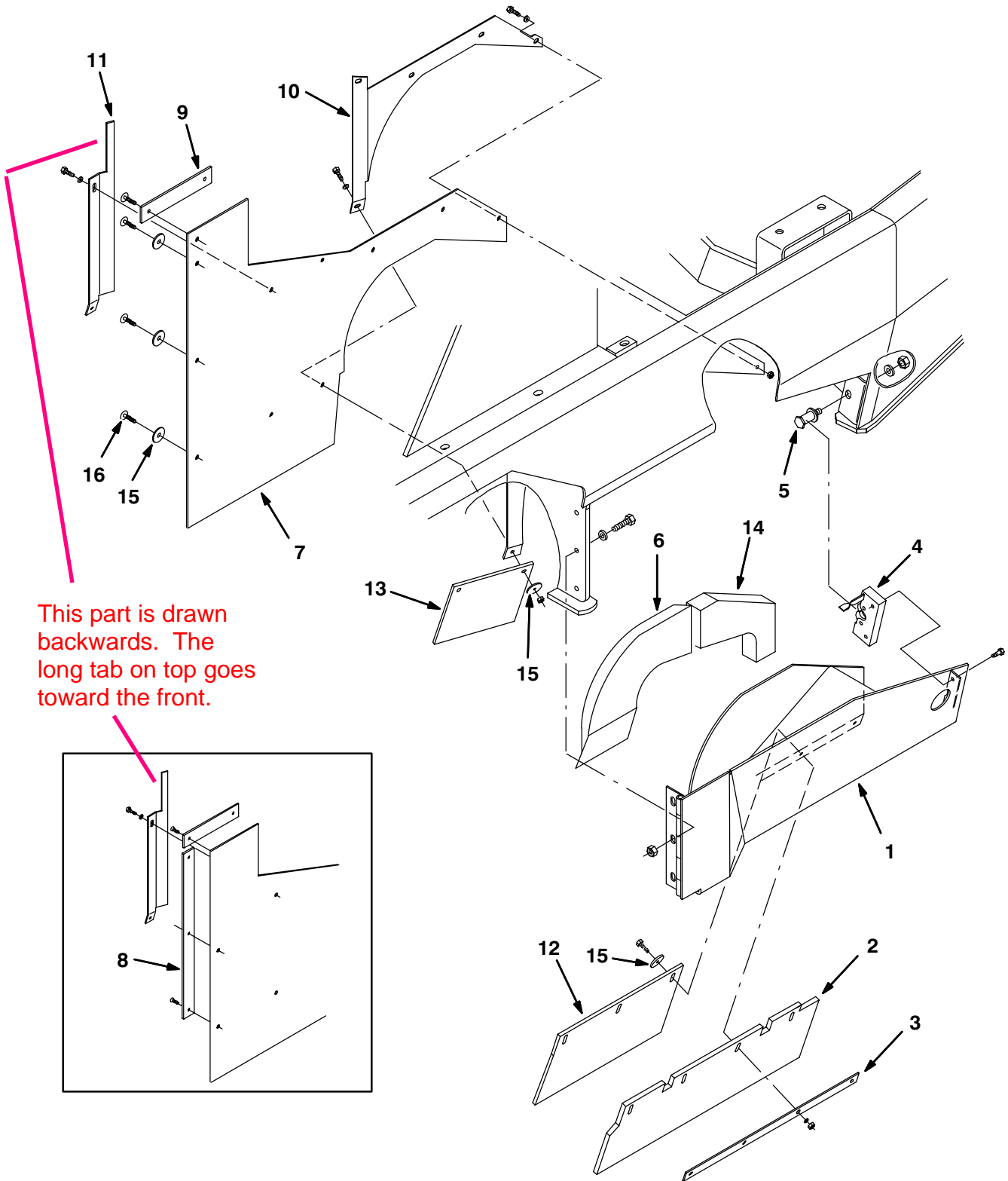

Fig. 5 – Left Brush Door Group

Ref.	Tennant Part No.	Machine Serial Number	Description	Qty.
1	64801	(000000–) Door Wldt, Brush, Lh	1
2	73870	(000000–) Skirt, Brush Door	1
3	70453	(000000–) Strip, Retainer, Skirt	1
4	58489	(000000–) Latch, Hook (Supplier'S Rh)	1
5	58898	(000000–) Bolt, Latch	1
6	70809	(000000–) Seal, Door, Brush, Lh	1
7	73654	(000000–) Seal, Brush Comp, Side	1
8	64923	(000000–001320) Strip, Retainer, Seal, Side	1
9	21282	(000000–) Strip, Retainer, Seal, Side	1
10	70597	(000000–) Angle, Retainer, Seal	1
11	73648	(000000–) Strip, Retainer, Seal, Lh	1
12	64788	(000000–) Skirt, Brush Door	1
13	73888	(000000–) Skirt, Front, Indoor	1
14	74062	(000000–) Seal, Brush Door	1
15	41178	(000000–) Fender Washer	7
16	21168	(001321–) Rivet, Plastic	5

Fig. 6 – Right Brush Door Group

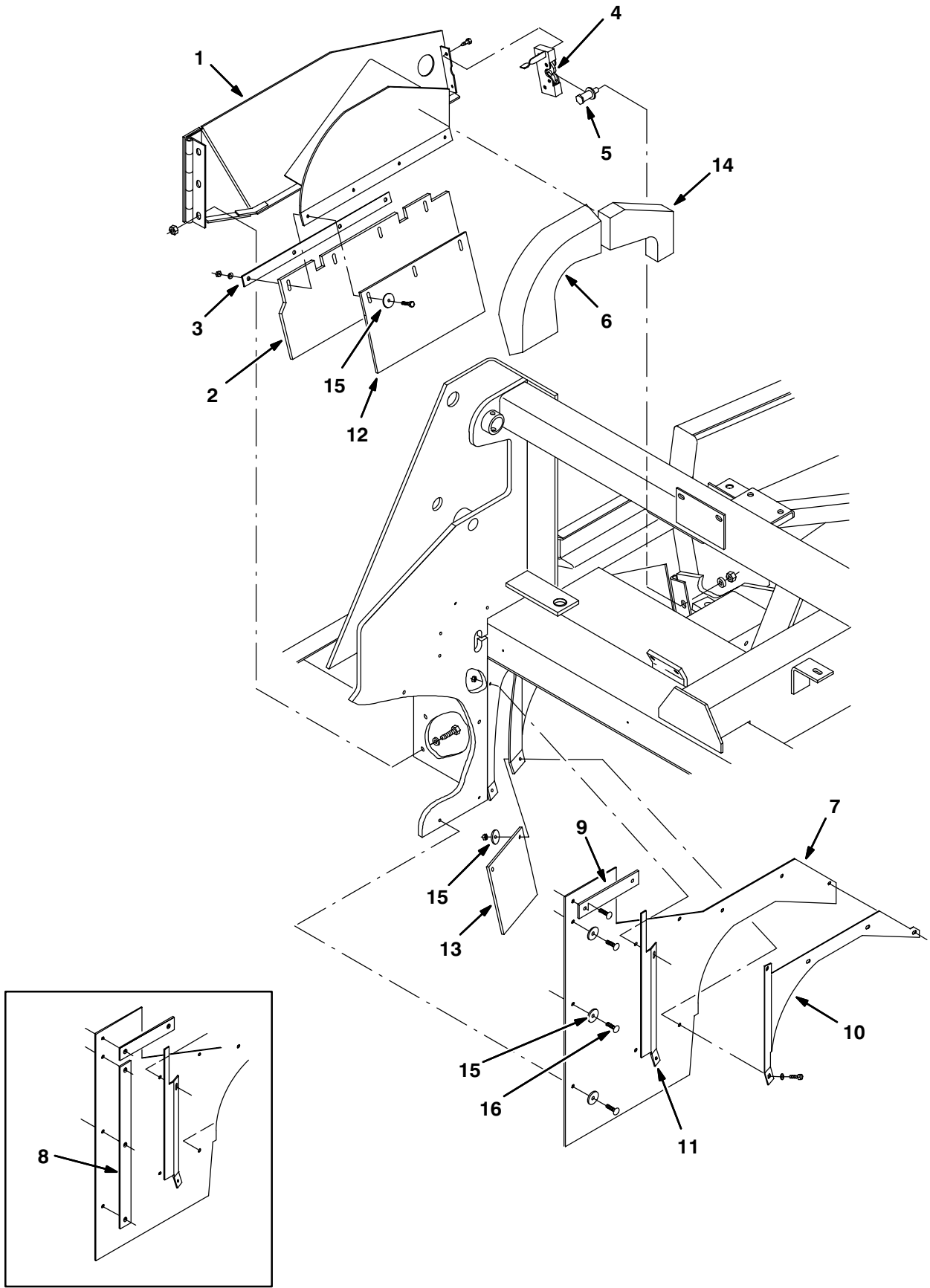

Fig. 6 – Right Brush Door Group

Ref.	Tenant Part No.	Machine Serial Number	Description	Qty.
1	64802	(000000–) Door Wldt, Brush, Rh	1
2	73870	(000000–) Skirt, Brush Door	1
3	70453	(000000–) Strip, Retainer, Skirt	1
4	58844	(000000–) Latch, Hook (Supplier's Lh)	1
5	58898	(000000–) Bolt, Latch	1
6	70808	(000000–) Seal, Door, Brush, Rh	1
7	73654	(000000–) Seal, Brush Comp, Side	1
8	64923	(000000–001320) Strip, Retainer, Seal, Side	1
9	21282	(000000–) Strip, Retainer, Seal, Side	1
10	70598	(000000–) Angle, Retainer, Seal	1
11	73649	(000000–) Strip, Retainer, Seal, Rh	1
12	64788	(000000–) Skirt, Brush Door	1
13	73888	(000000–) Skirt, Front, Indoor	1
14	74063	(000000–) Seal, Brush Door	1
15	41178	(000000–) Fender Washer	7
16	21168	(001321–) Rivet, Plastic	5

Fig. 7 – Operator Station Group

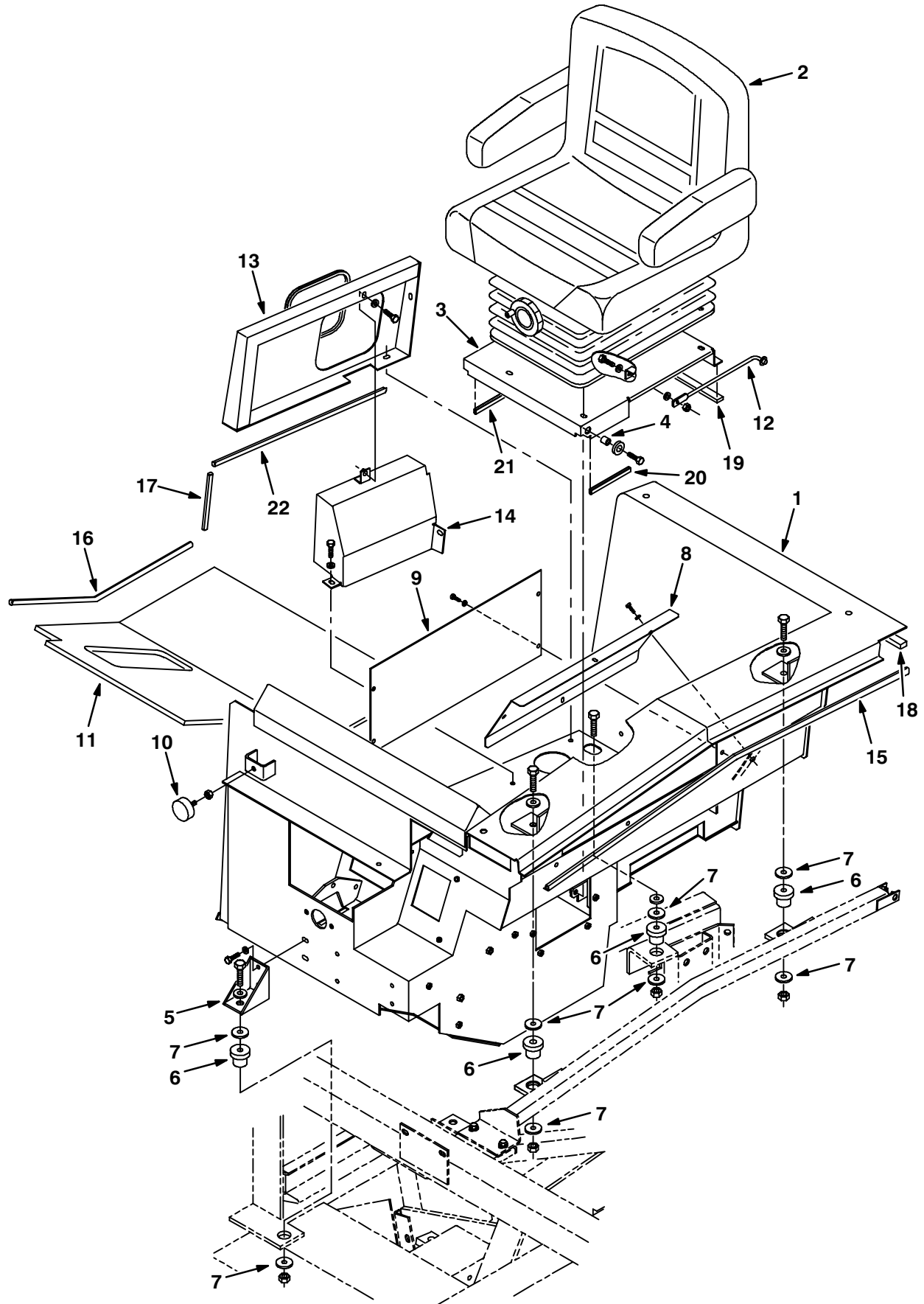

Fig. 7 – Operator Station Group

Ref.	Tennant Part No.	Machine Serial Number	Description	Qty.
1	63710	(000000-001119)	Panel Wldt, Oper Comp	1
2	63294	(000000-001119)	Seat, Suspension	1
3	70478	(000000-001119)	Panel Wldt, Support, Seat	1
4	40716	(000000-001119)	Sleeve, .385B .62D .62 Cd.Cad	2
5	63751	(000000-001119)	Bracket Wldt, Oper Comp	1
6	51176	(000000-001119)	Dampner, Engine	4
7	04414	(000000-001119)	Washer, Flat	8
8	64884	(000000-001119)	Panel, Cover, Access	1
9	70450	(000000-001119)	Panel, Air Conditioning	1
10	70756	(000000-001119)	Bumper, Rubber	1
11	73691	(000000-001119)	Tread, Floormat, Rubber	1
12	54615	(000000-001119)	Rod Wldt, Seat	1
13	70564	(000000-001119)	Panel, Fuel Inlet	1
14	70620	(000000-001119)	Cover Wldt, Fuel Inlet	1
15	57820	(000000-001119)	Seal, 48.0 Lg.	1
16	73903	(000000-001119)	Seal, 24.5 Lg	1
17	73901	(000000-001119)	Seal, 7.00 Lg	1
18	74081	(000000-001119)	Seal, 66.0 Lg	1
19	44777	(000000-001119)	Seal,Foam Rbr, .31 .75W 14.8L	1
20	57564	(000000-001119)	Molding, Trim 11-14Ga 5.00	1
21	62595-2	(000000-001119)	Molding, Trim 11-14Ga 15.75	1
22	04664	(000000-001119)	Seal, 27.25L	1

Fig. 8 – Operator Station Group

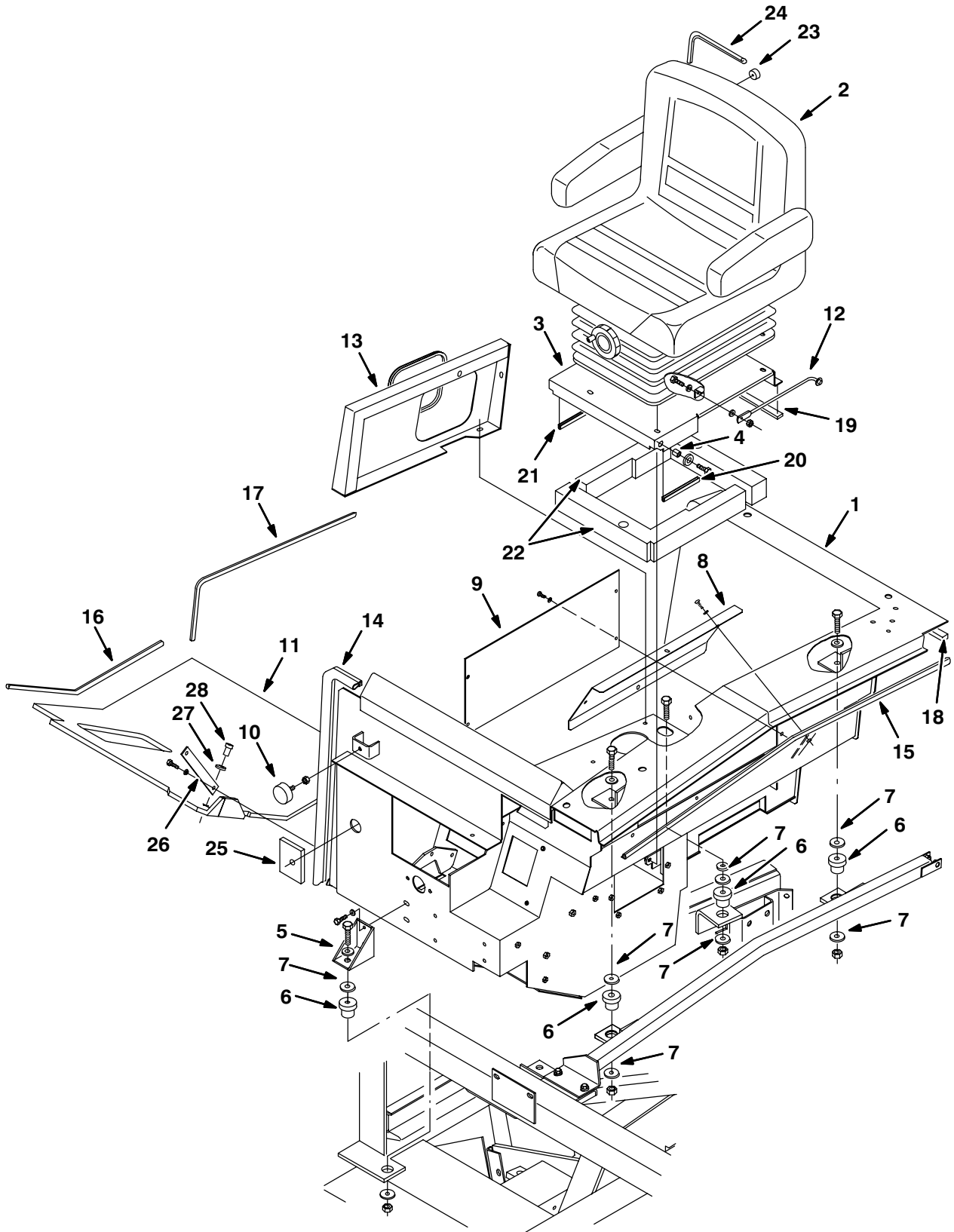

Fig. 8 – Operator Station Group

Ref.	Tenant Part No.	Machine Serial Number	Description	Qty.
1	75860	(001120–)	Panel Wldt W/Label	1
2	63294	(001120–)	Seat, Suspension	1
3	70478	(001120–)	Panel, Support, Seat	1
4	40716	(001120–)	Sleeve, .385B .62D .62 Cd.Cad	2
5	63751	(001120–)	Bracket, Oper Comp	1
6	51176	(001120–)	Dampner, Engine	4
7	04414	(001120–)	Washer, .531B 1.88D .12Hard Zn	8
8	64884	(001120–)	Panel, Cover, Access	1
9	70450	(001120–)	Panel, Air Conditioning	1
10	70756	(001120–)	Bumper, Rubber	1
11	76495	(001120–)	Tread, Floormat, Rubber	1
12	54615	(001120–)	Rod, Seat	1
13	70564	(001120–)	Panel, Fuel Inlet	1
14	77340	(001120–)	Seal, Bulb, Sd–0504 28.00 Lg	1
15	57820	(001120–)	Seal, 48.0 Lg.	1
16	73903	(001120–)	Seal, Bulb, Sd–0504 24.50Lg	1
17	73901	(001120–)	Seal, 7.00 Lg	1
18	74081	(001120–)	Seal	1
19	44777	(001120–)	Seal,Foam Rbr, .31 .75W 14.8L	1
20	62595–3	(001120–)	Molding, Trim 11–14Ga 5.75	1
21	62595–2	(001120–)	Molding, Trim 11–14Ga 15.75	1
22	76285	(001120–)	Insulation, S/Foam, Seat	2
23	82921	(001120–)	Bumper, Rubber	1
24	49282	(001120–)	Molding, Trim 16Ga&Thinnr 10.0	1
25	79028	(001120–)	Seal, Rod, Adjuster	1
26	76492	(001120–)	Bar, Retainer	1
27	41178	(001120–)	Washer–Flt .25 Fender Rltd.	1
28	21246	(001120–)	Rivet, Plastic .325D X .787	1

Fig. 9 – Engine Cover and Lintel Group

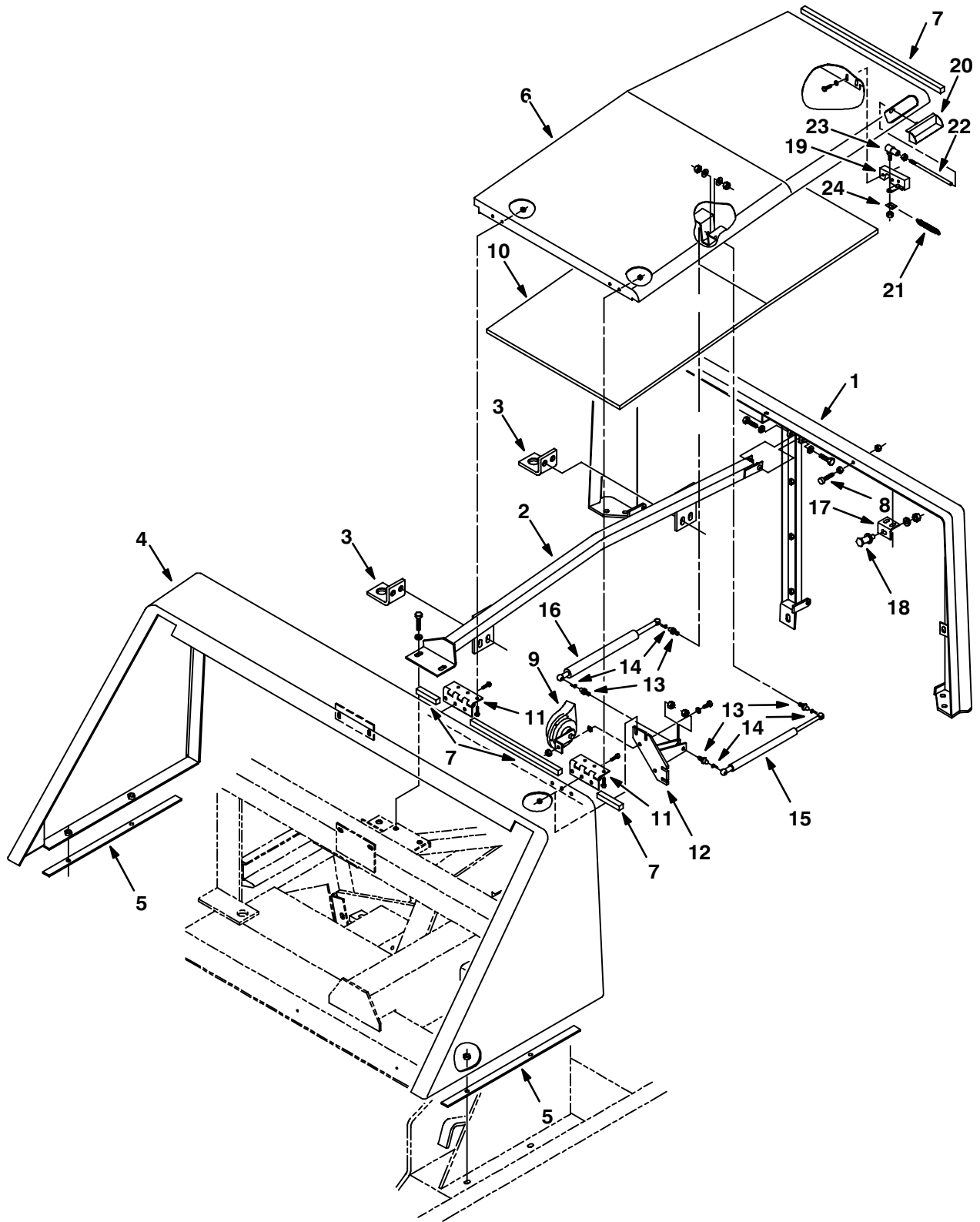

Fig. 9 – Engine Cover and Lintel Group

Ref.	Tennant Part No.	Machine Serial Number	Description	Qty.
1	64312	(000000-001251)	Lintel Wldt, Rear	1
2	64744	(000000-001251)	Tube Wldt, Brace, Center	1
3	64726	(000000-001251)	Bracket, Brace, Center	2
4	64278	(000000-001251)	Lintel Wldt, Main	1
5	64279	(000000-001251)	Strip, Spacer	2
6	64440	(000000-001251)	Cover Wldt, Engine	1
7	53461-2	(000000-001251)	Seal,Foam Rbr, .62 .62W 24.5L	2
8	75128	(000000-001251)	Spindle, Adjustment	1
9	14138A	(000000-001251)	Horn, 12V	1
10	70596	(000000-001251)	Insulation, S/Foam	1
11	74040	(000000-001251)	Hinge	2
12	65003	(000000-001251)	Bracket Wldt, Gas Spring	1
13	58494	(000000-001251)	Stud, Ball, Gas Spring	4
14	64595	(000000-001251)	Clip, Safety	4
15	31182	(000000-001251)	Spring-Gas 75Lb 6.3 Stroke	1
16	82334	(000000-001251)	Spring-Gas 120Lb 6.3 Stroke	1
17	70408	(000000-001251)	Angle, Bolt, Latch, Cover	1
18	59703	(000000-001251)	Bolt, Hook, Rh	1
19	59661	(000000-001251)	Latch	1
20	73841	(000000-001251)	Handle Wldt, Latch	1
21	29260	(000000-001251)	Sprng,Tens,0.37Odx.05Wire 4.5L	1
22	73843	(000000-001251)	Rod-Thrd, 1End M06X1.0 X 6.40	1
23	12263	(000000-001251)	Balljoint M 6X1.0	1
24	73893	(000000-001251)	Strip	1

Fig. 10 – Engine Cover and Lintel Group

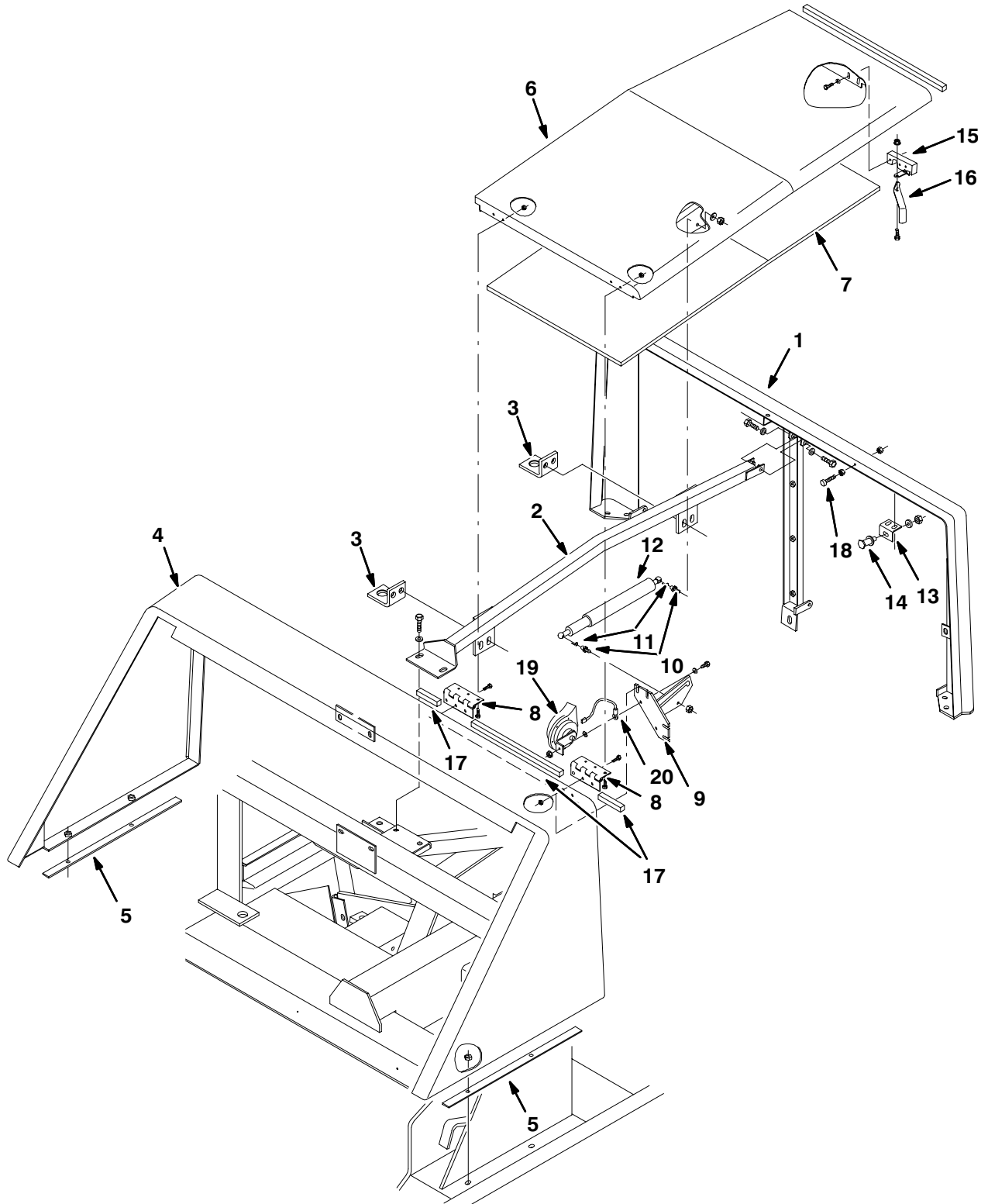

Fig. 10 – Engine Cover and Lintel Group

Ref.	Tennant Part No.	Machine Serial Number	Description	Qty.
1	64312	(001252–)	Lintel, Rear	1
2	64744	(001252–)	Tube Wldt, Brace, Center	1
3	64726	(001252–)	Bracket, Brace, Center	2
4	64278	(001252–)	Lintel, Main	1
5	64279	(001252–)	Strip, Spacer	2
6	79002	(001252–)	Cover Wldt, Engine	1
7	70596	(001252–)	Insulation, S/Foam	1
8	74040	(001252–)	Hinge	2
9	21131	(001252–)	Brkt Wldt , Gas Spring	1
10	58494	(001252–)	Stud, Ball, Gas Spring	2
11	64595	(001252–)	Clip Safety	2
12	77728	(001252–)	Spring, Gas	1
13	70408	(001252–)	Angle, Bolt, Latch, Cover	1
14	59703	(001252–)	Bolt, Hook, Rh	1
15	59661	(001252–)	Latch	1
16	79009	(001252–)	Lever, Handle, Latch	1
17	53461–2	(001252–)	Seal,Foam Rbr, .62 .62W 24.5L	2
18	75128	(001252–)	Spindle, Adjustment	1
19	21642	(001252–)	Horn, 12V	1
20	21643	(001252–)	Wire, Lead	1

Fig. 11 – Engine Side Door Group

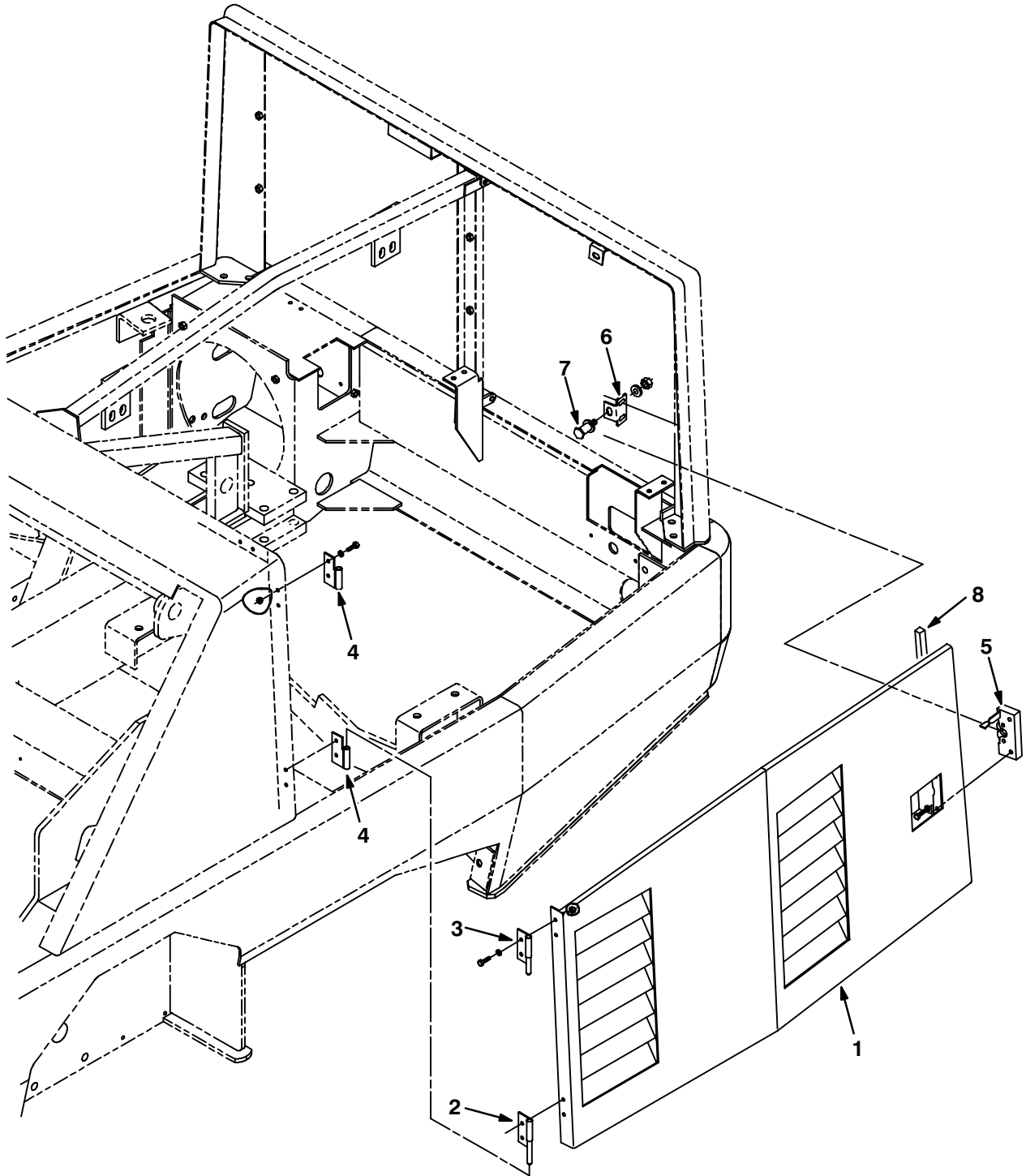

Fig. 11 – Engine Side Door Group

Ref.	Tennant Part No.	Machine Serial Number	Description	Qty.
1	77475	(000000–001169)	Door Wldt, Engine Replacement Kit	1
2	64543	(000000–001169)	Hinge Wldt, W/Pin	1
3	70628	(000000–001169)	Hinge Wldt, W/Pin	1
4	64545	(000000–001169)	Hinge Wldt	2
5	58489	(000000–001169)	Latch, Hook (Supplier'S Rh)	1
6	70407	(000000–001169)	Angle, Bolt, Latch	1
7	59192	(000000–001169)	Latch, Bolt	1
8	53461–2	(000000–001169)	Seal,Foam Rbr, .62 .62W 24.5L	1

Fig. 12 – Engine Side Door Group

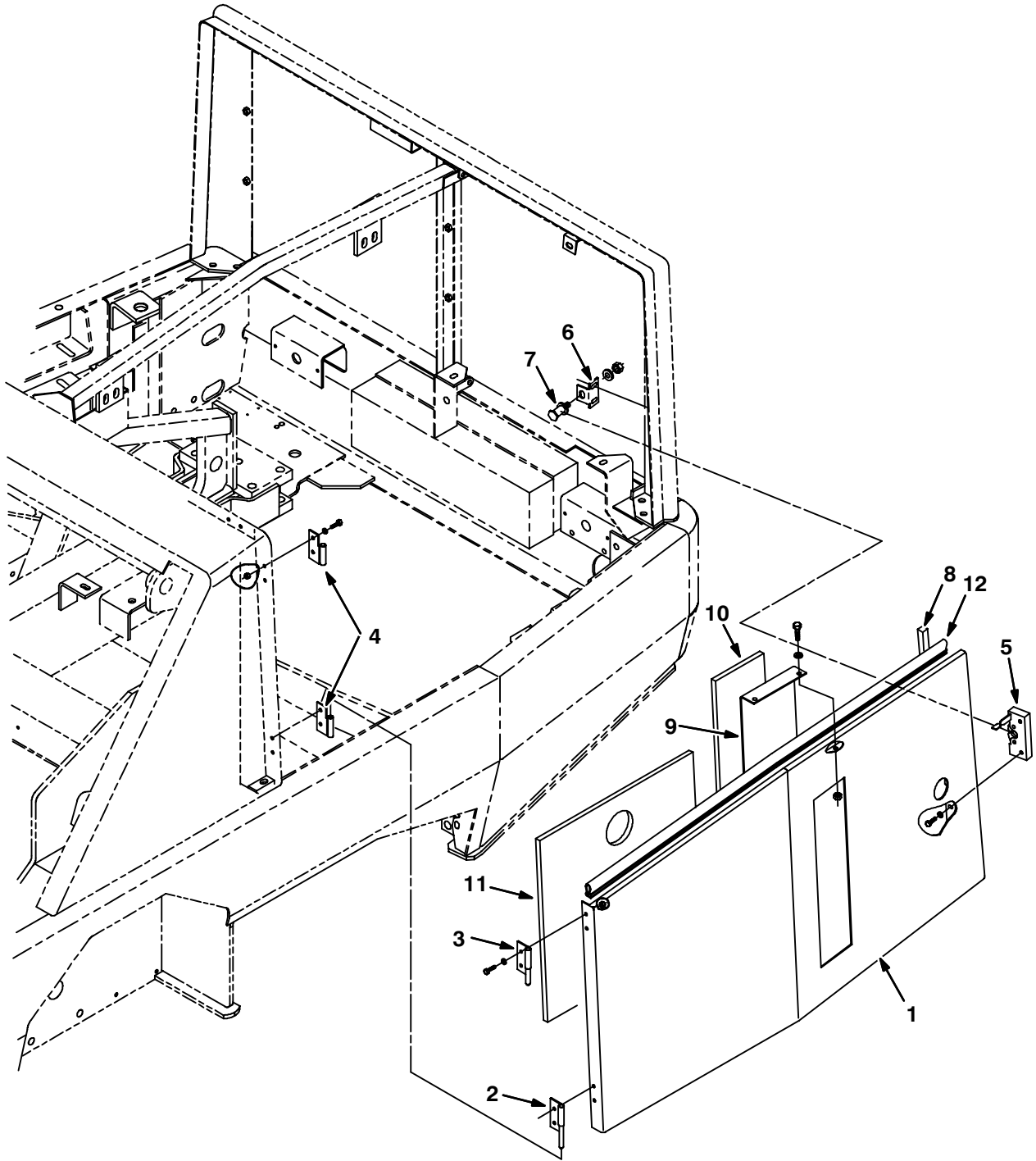

Fig. 12 – Engine Side Door Group

Ref.	Tennant Part No.	Machine Serial Number	Description	Qty.
1	77470	(001170–)	Door Wldt, Engine	1
2	64543	(001170–)	Hinge, W/Pin	1
3	70628	(001170–)	Hinge, W/Pin	1
4	64545	(001170–)	Hinge	2
5	58489	(001170–)	Latch, Hook Rh	1
6	70407	(001170–)	Angle, Bolt, Latch	1
7	59192	(001170–)	Latch, Bolt	1
8	53461–2	(001170–)	Seal,Foam Rbr, .62 .62W 24.5L	1
9	77467	(001170–)	Panel	1
10	77630	(001170–)	Insulation, S/Foam	1
11	77642	(001170–)	Insulation, S/Foam	1
12	57820	(001170–)	Seal, 48.0 Lg.	1

Fig. 13 – Grille and Hydraulic Cooler Group

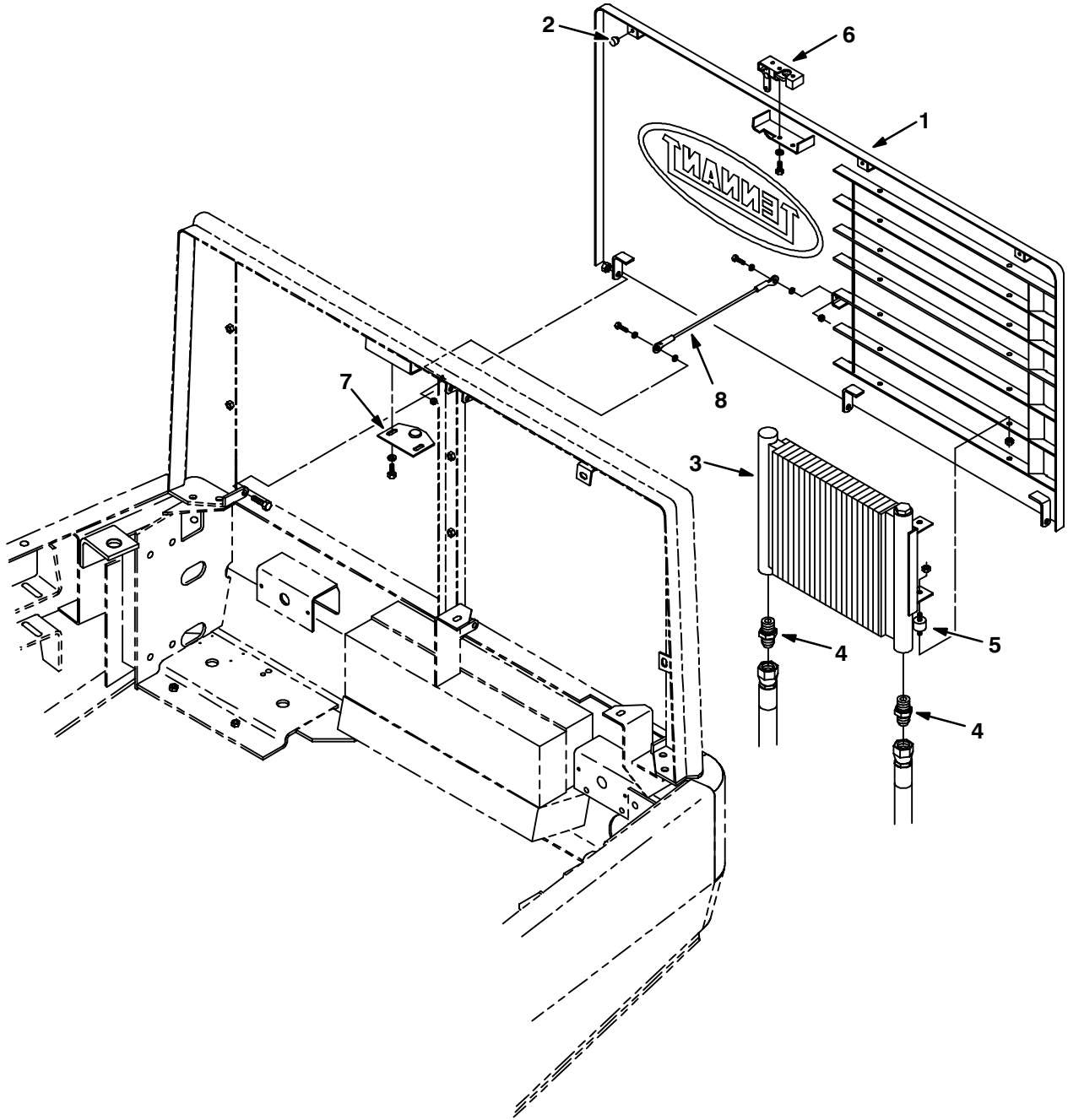

Fig. 13 – Grille and Hydraulic Cooler Group

Ref.	Tennant Part No.	Machine Serial Number	Description	Qty.
1	70552	(000000–)	Door Wldt, Rear	1
2	51787	(000000–)	Bumper, Rubber	3
3	64419	(000000–)	Cooler–Hyd	1
4	42260	(000000–)	Ftg–Hyd Str Jm12/Om12	2
5	51322	(000000–)	Isolator–Vibration .31–18	4
6	59661	(000000–)	Latch	1
7	65252	(000000–)	Plate, Striker	1
8	36192	(000000–)	Lanyard Assy.	1

Fig. 14 – Hopper Lift Arms Group

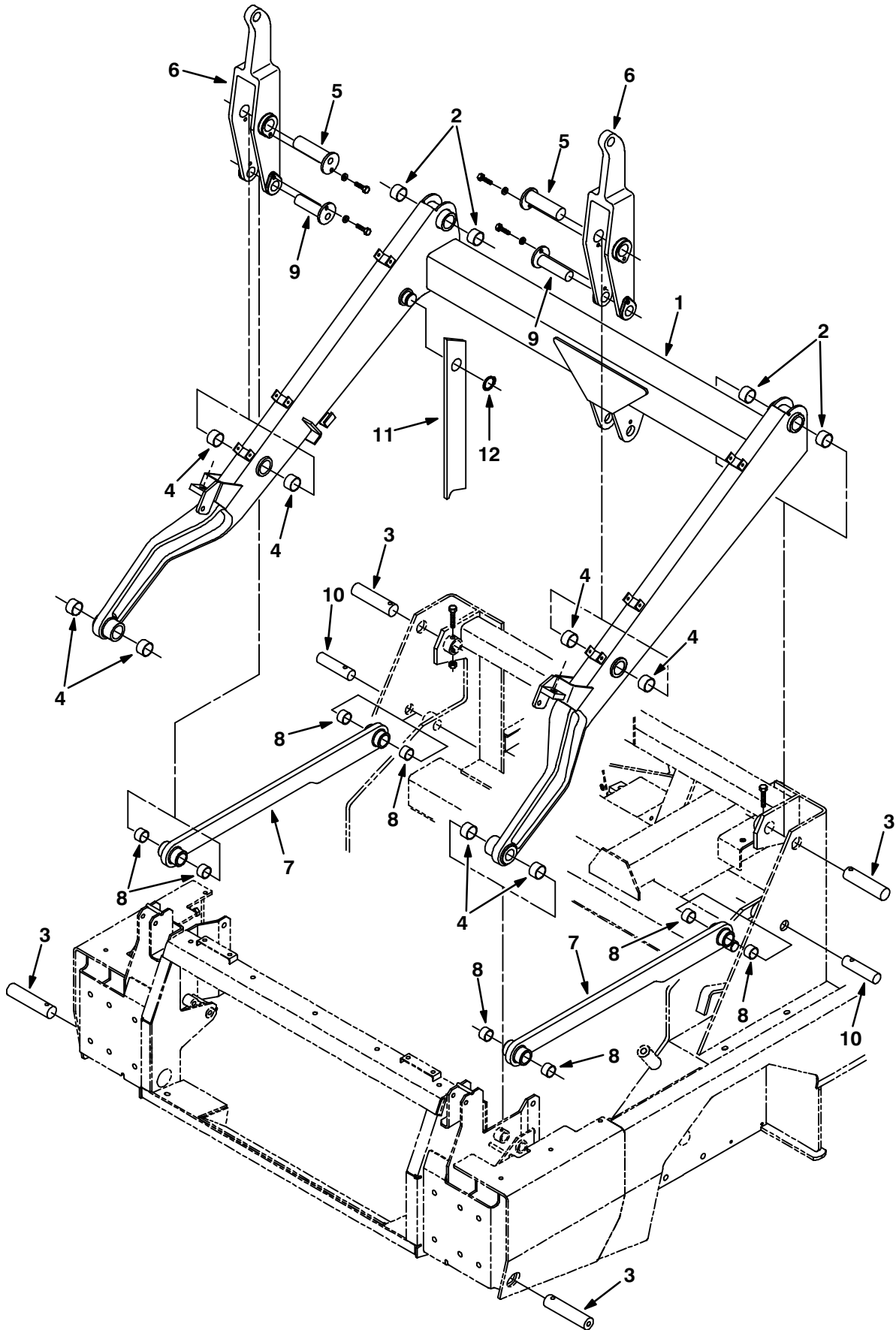

Fig. 14 – Hopper Lift Arms Group

Ref.	Tennant Part No.	Machine Serial Number	Description	Qty.
1	62996	(000000-001184)	Arm Wldt, Hopper Lift	1
2	58293	(000000-001184)	Bearng-Journal	4
3	62991	(000000-001184)	Pin, 1.500 Odx6.50, Drilled	4
4	58293	(000000-001184)	Bearng-Journal	8
5	62992	(000000-001184)	Pin Wldt, 1.500 Odx 5.00	2
6	62988	(000000-001102)	Link, Pivot, Machined	2
7	62985	(000000-001102)	Bar, Lower Arm, Machining	2
8	57936	(000000-001184)	Bearing-Journal	8
9	62993	(000000-001184)	Pin Wldt, 1.250 Od X 4.50	2
10	62990	(000000-001095)	Pin, 1.25 Odx 5.00, Drilled	2
11	63776	(000000-001184)	Arm, Safety	1
12	63926	(000000-001184)	Ring, Retaining, Ex 1.5 Dia Hd	1

Fig. 15 – Hopper Lift Arms Group

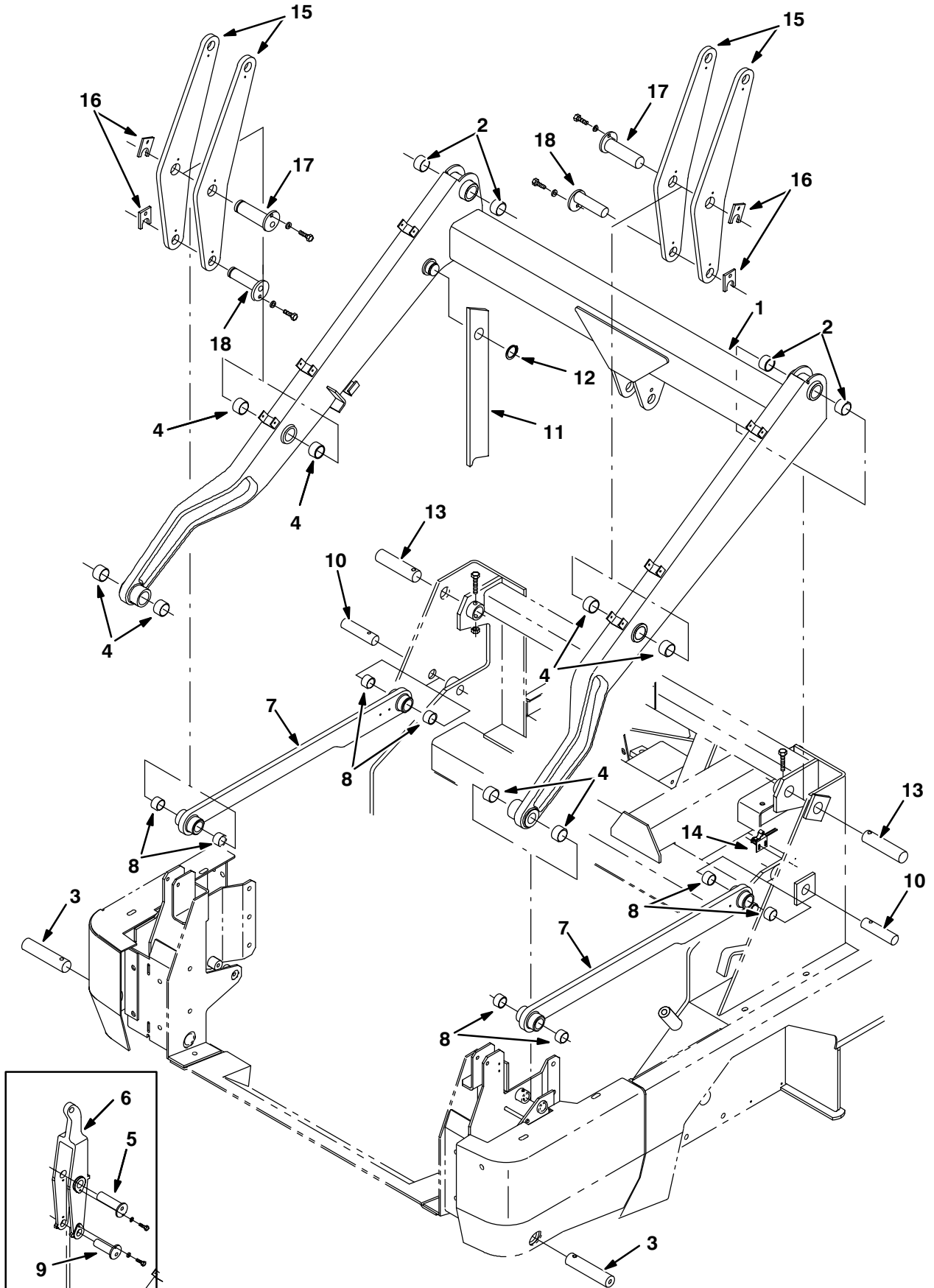

Fig. 15 – Hopper Lift Arms Group

Ref.	Tennant Part No.	Machine Serial Number	Description	Qty.
1	62996	(001185 –)	Arm Wldt, Hopper Lift	1
2	58293	(001185–)	Bearng–Journal	4
3	77463	(001185–)	Pin, 1.500 ODx7.81, Drilled	2
4	58293	(001185–)	Bearng–Journal	8
5	62992	(001185–001699)	Pin, 1.500 Odx 5.00	2
6	76237	(001103–001699)	Link, Pivot	2
7	76235	(001103–)	Bar, Arm, Lower, Machining	2
8	57936	(001185–)	Bearing–Journal	2
9	62993	(001185–001699)	Pin, 1.250 Od X 4.50	2
10	76470	(001096–)	Pin	2
11	63776	(001185–)	Arm, Safety	1
12	63926	(001185–)	Ring, Retaining, Ex 1.5 Dia Hd	1
13	76471	(001185–)	Pin	2
14	59965	(001185–)	Switch, Roller	1
15	83549	(001700–)	Plate, Link	4
16	83554	(001700–)	Plate, Pin Retainer	4
17	83551	(001700–)	Pin Weldt.	2
18	83553	(001700–)	Pin Weldt.	2

Fig. 16 – Hopper Lift Cylinders Group

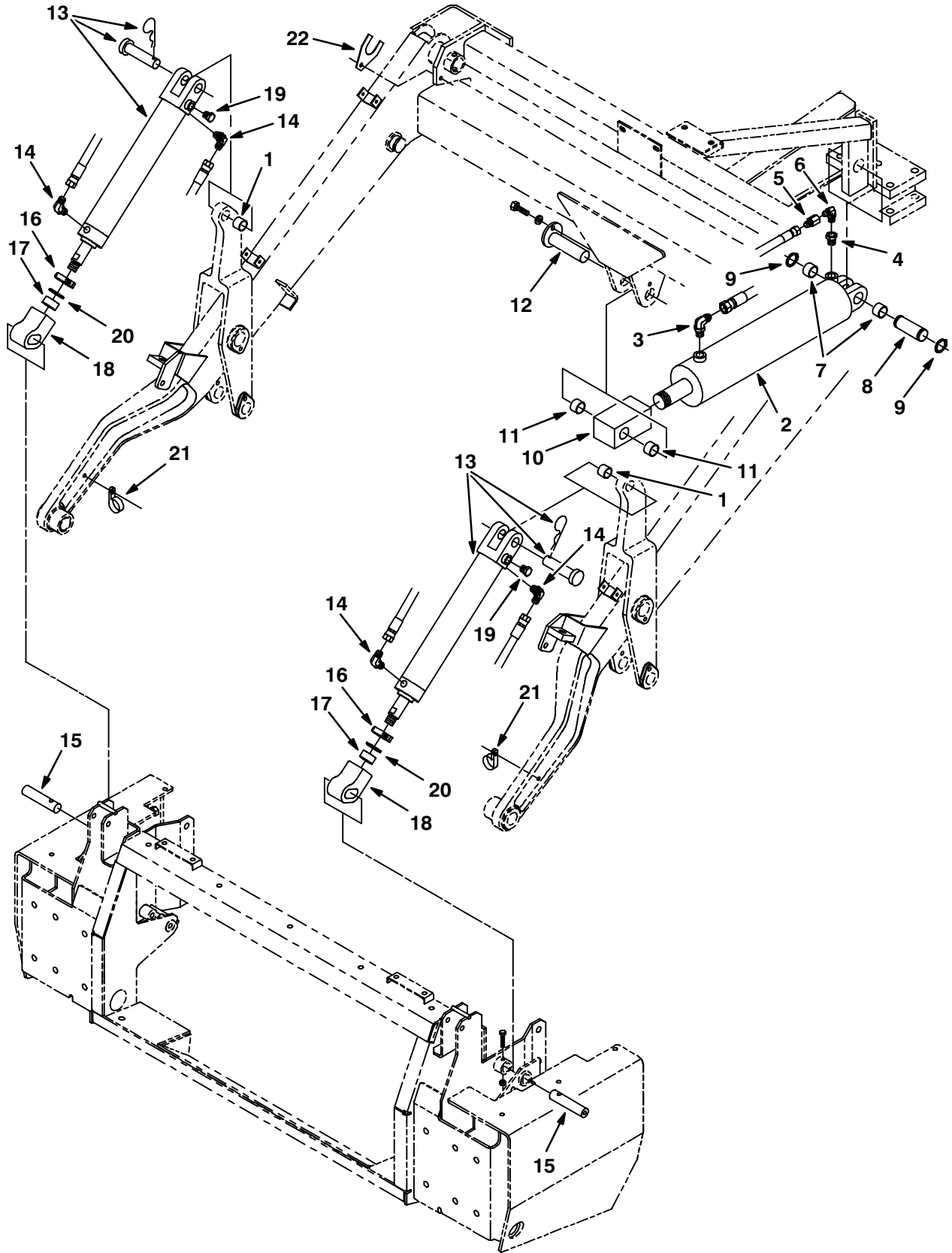

Fig. 16 – Hopper Lift Cylinders Group

Ref.	Tennant Part No.	Machine Serial Number	Description	Qty.
1	35529	(000000-001241)	Bearing, Journal	2
2	62975	(000000-001241)	Cylinder, Hyd (See Breakdowns)	1
3	47512	(000000-001241)	Ftg-Hyd E90 Jm06/Om08	1
4	55686	(000000-001241)	Ftg-Hyd Str Jm04/Om08	1
5	16456	(000000-001241)	Ftg-Hyd Rst Jm04/.063	1
6	39210	(000000-001241)	Ftg-Hyd E90 Jm04/Jf04	1
7	63585	(000000-001241)	Bearing, Journal	1
8	63583	(000000-001241)	Pin, 1.25 Odx 3.50, Grooved	1
9	58359	(000000-001241)	Retaining Ring-External, 1.25D	2
10	64156	(000000-001241)	Bar, Cylinder End	1
11	57936	(000000-001241)	Bearing-Journal	2
12	62993	(000000-001241)	Pin Wldt, 1.250 Od X 4.50	1
1036653	65223	(000000-001241)	Cylinder, Hyd (See Breakdowns)	2
14	47638	(000000-001241)	Ftg-Hyd E90 Jm04/Om06	4
15	63584	(000000-001241)	Pin, 1.00 Odx 4.50, Drilled	2
16	70459	(000000-001241)	Collar, Clamping	2
17	70523	(000000-001241)	Spacer	2
18	70514	(000000-001241)	Bar, Cylinder End	2
19	46482	(000000-001241)	Ftg-Hyd Plg Om06	2
20	73736	(000000-001241)	Washer,1.142B 1.75D .07 Lcs	2
21	67767	(000000-001241)	Clamp-Cable	2
22	75891	(000000-001241)	Shim	2

Fig. 17 – Hopper Lift Cylinders Group

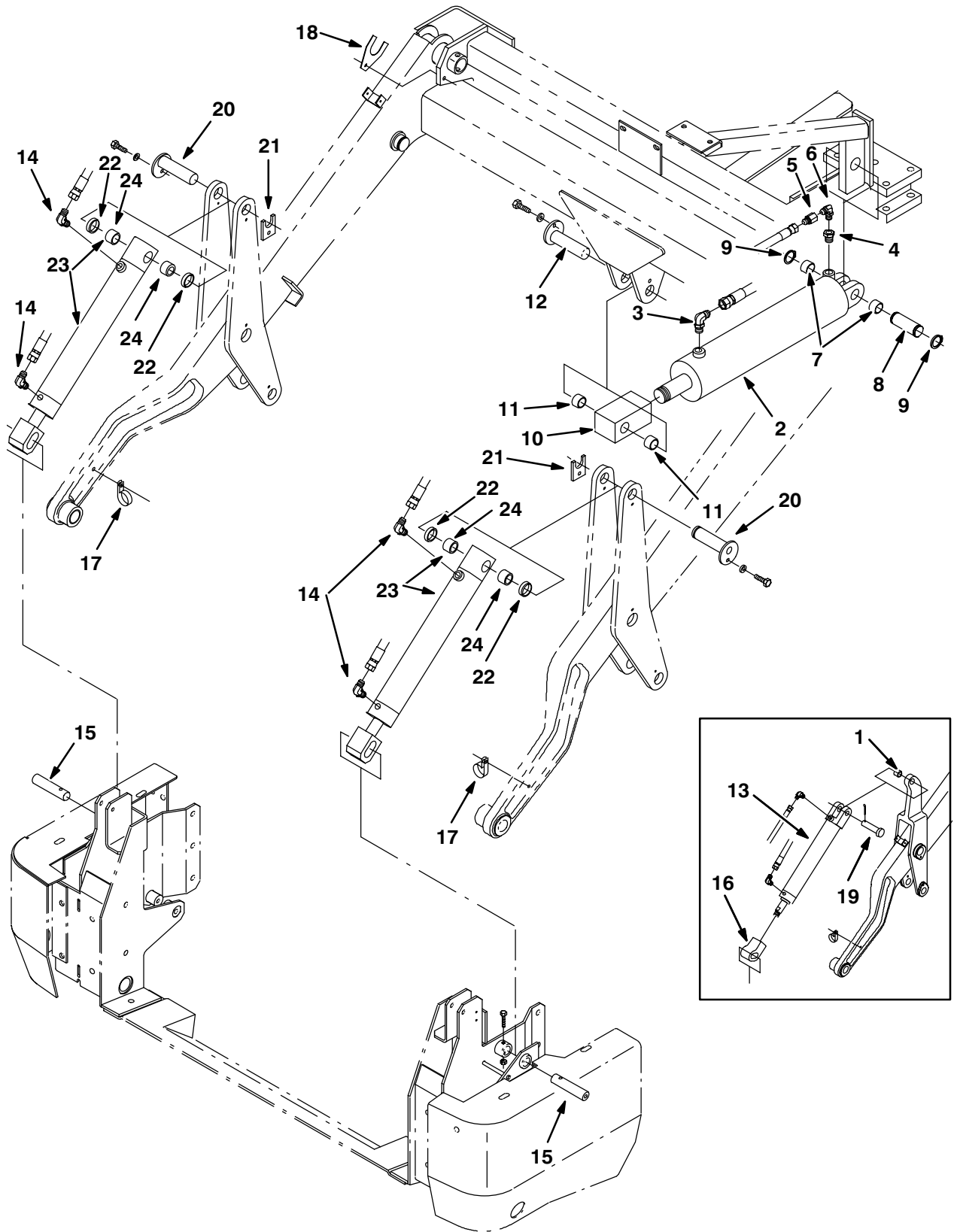

Fig. 17 – Hopper Lift Cylinders Group

Ref.	Tennant Part No.	Machine Serial Number	Description	Qty.	
1	35529	(001242-001699)	Bearing, Journal	2	
2	62975	(001242-)	Cylinder, Hyd 4.0B 14.5S 2500 (See Breakdowns)	1	
3	47512	(001242-)	Ftg-Hyd E90 Jm06/Om08	1	
4	55686	(001242-)	Ftg-Hyd Str Jm04/Om08	1	
5	16456	(001242-)	Ftg-Hyd Rst Jm04/.063	1	
6	39210	(001242-)	Ftg-Hyd E90 Jm04/Jf04	1	
7	63585	(001242-)	Bearing, Journal	1	
8	63583	(001242-)	Pin, 1.25 Odx 3.50, Grooved	1	
9	58359	(001242-)	Retaining Ring-External, 1.25D	2	
10	64156	(001242-)	Bar, Cylinder End	1	
11	57936	(001242-)	Bearing-Journal	2	
12	83553	(001242-)	Pin, 1.250 Od X 4.50	1	
1036652	77780	(001242-001699)	Cylinder, Hyd 2.0B 11.6S 2500	2	
14	47638	(001242-)	Ftg-Hyd E90 Jm04/Om06	4	
15	63584	(001242-)	Pin, 1.00 Odx 4.50, Drilled	2	
16	70514	(001242-001699)	Bar, Cylinder End	2	
17	67767	(001242-)	Clamp-Cable,.69Dia. 62Wth	2	
18	75891	(001242-)	Plate, Spacer	2	
19	04733-4	(001242-001699)	Pin,Clevis,1.00 Dia.X 2.50 Lg	2	
20	83553	(001700-)	Pin Wldt.	2	
21	83554	(001700-)	Plate, Pin Retainer	2	
22	83555	(001700-)	Spacer	4	
∇	23	21304	(001700-)	Cylinder, hyd. 2.0 B 14.9S 2500	2
	24	57936	(001700-)	Bearing-Journal	2

Fig. 18 – Hopper Group

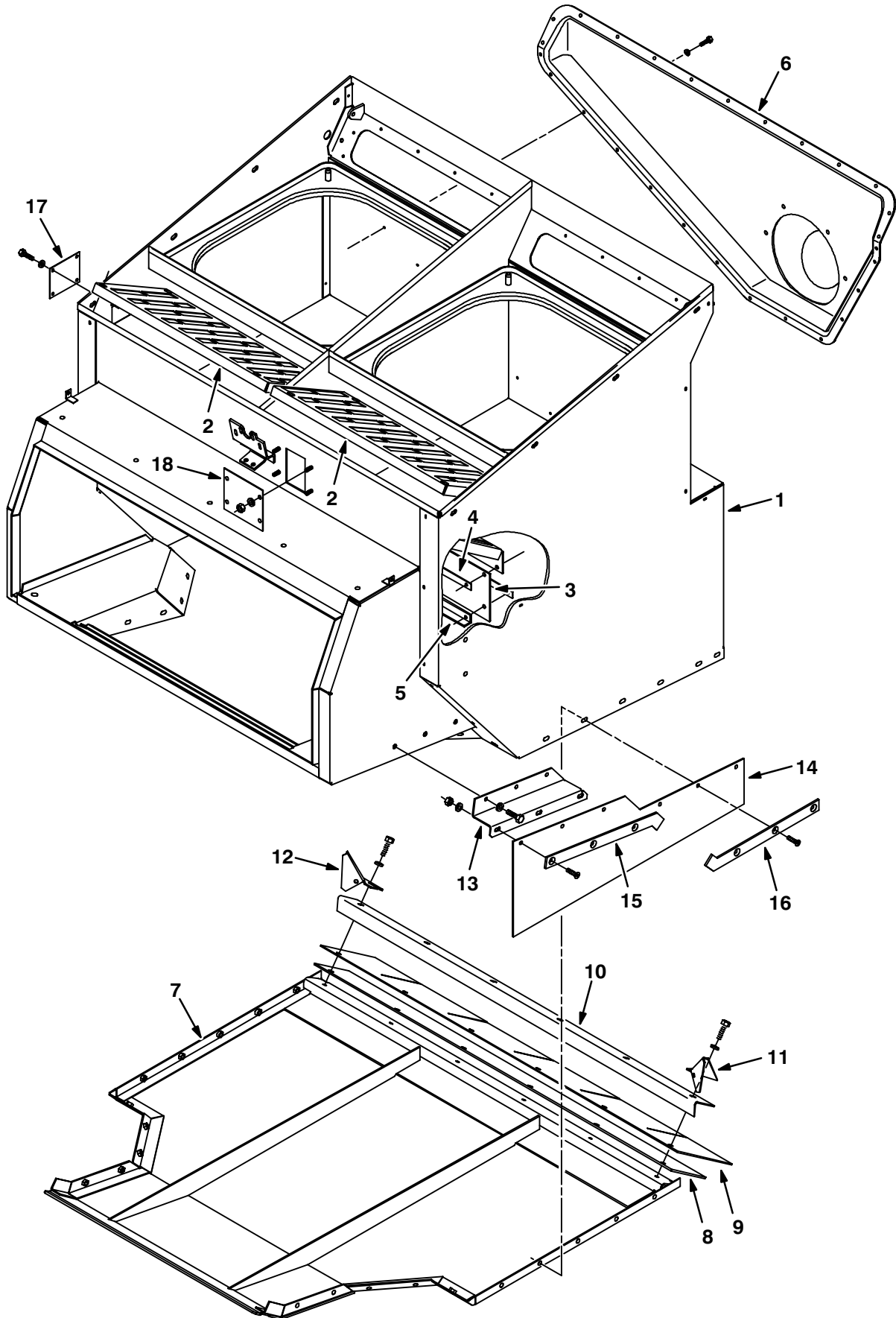

Fig. 18 – Hopper Group

Ref.	Tennant Part No.	Machine Serial Number	Description	Qty.
1	63673	(000000-001113)	Hopper Wldt	1
2	63665	(000000-001113)	Panel, Permafilter, Upper	2
3	63667	(000000-001113)	Seal, Dust	1
4	63668	(000000-001113)	Bar, Retainer, Dust Seal	1
5	63669	(000000-001113)	Angle, Dust Seal	1
6	70388	(000000-001113)	Duct, Inlet, Vac Fan	1
7	63648	(000000-001113)	Panel Wldt	1
8	73678	(000000-001113)	Skirt, Lip	1
9	73679	(000000-001113)	Skirt, Lip	1
10	63647	(000000-001113)	Angle, Retainer, Lip	1
11	74046	(000000-001113)	Panel, Deflector, Dirt, Rh	1
12	74045	(000000-001113)	Panel, Deflector, Dirt, Lh	1
13	73772	(000000-001113)	Bracket, Mtg, Skirt	1
14	73771	(000000-001113)	Skirt, Deflector	1
15	73749	(000000-001113)	Strip, Retainer, Skirt, Front	1
16	73748	(000000-001339)	Strip, Retainer, Skirt, Rear	1

Fig. 19 – Hopper Group

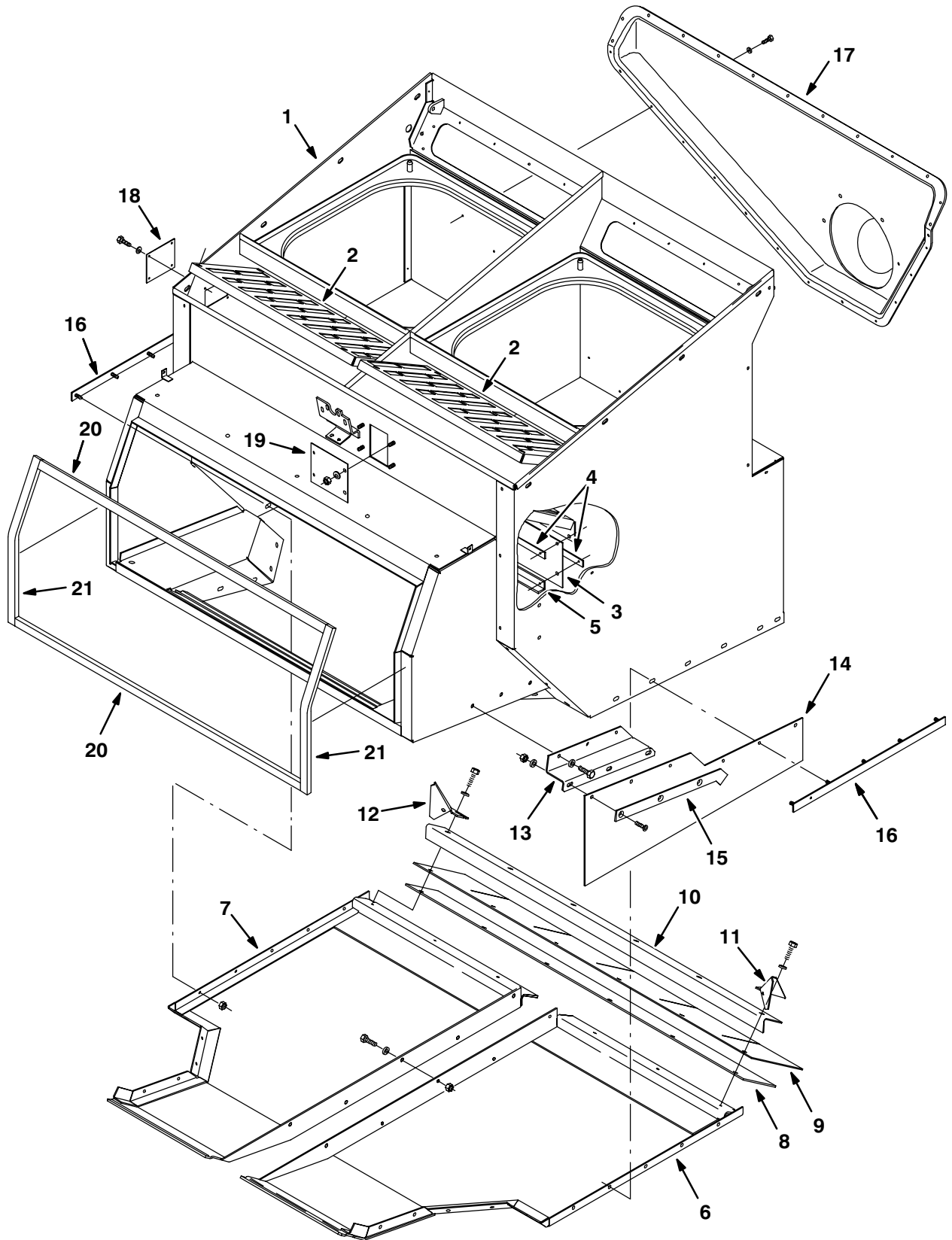

Fig. 19 – Hopper Group

Ref.	Tennant Part No.	Machine Serial Number	Description	Qty.
1	76487	(001114–)	Hopper Wldt	1
2	63665	(001114–)	Panel, Permafilter, Upper	2
3	63667	(001114–)	Seal, Dust	1
4	63668	(001114–)	Bar, Retainer, Dust Seal	2
5	63669	(001114–)	Angle, Dust Seal	1
6	76474	(001114–)	Panel, Hopper, Bottom, Lh	1
7	76384	(001114–)	Panel, Bottom, Hopper, Rh	1
8	73678	(001114–)	Skirt, Lip	1
9	73679	(001114–)	Skirt, Lip	1
10	63647	(001114–)	Angle, Retainer, Lip	1
11	74046	(001114–)	Panel, Deflector, Dirt, Rh	1
12	74045	(001114–)	Panel, Deflector, Dirt, Lh	1
13	73772	(001114–)	Bracket, Mtg, Skirt	1
14	73771	(001114–)	Skirt, Deflector	1
15	73749	(001114–)	Strip, Retainer, Skirt, Front	1
16	79139	(001340–)	Strip, Hopper	2
17	70388	(001114–)	Duct, Inlet, Vac Fan	1
18	74069	(001114–)	Plate, Cover	1
19	73887	(001114–)	Plate, Cover	1
20	79597	(001114–)	Seal, Foam, Urethane Covered	2
21	79600	(001114–)	Seal, Foam, Urethane Covered	2

Fig. 20 – Hopper Door Group

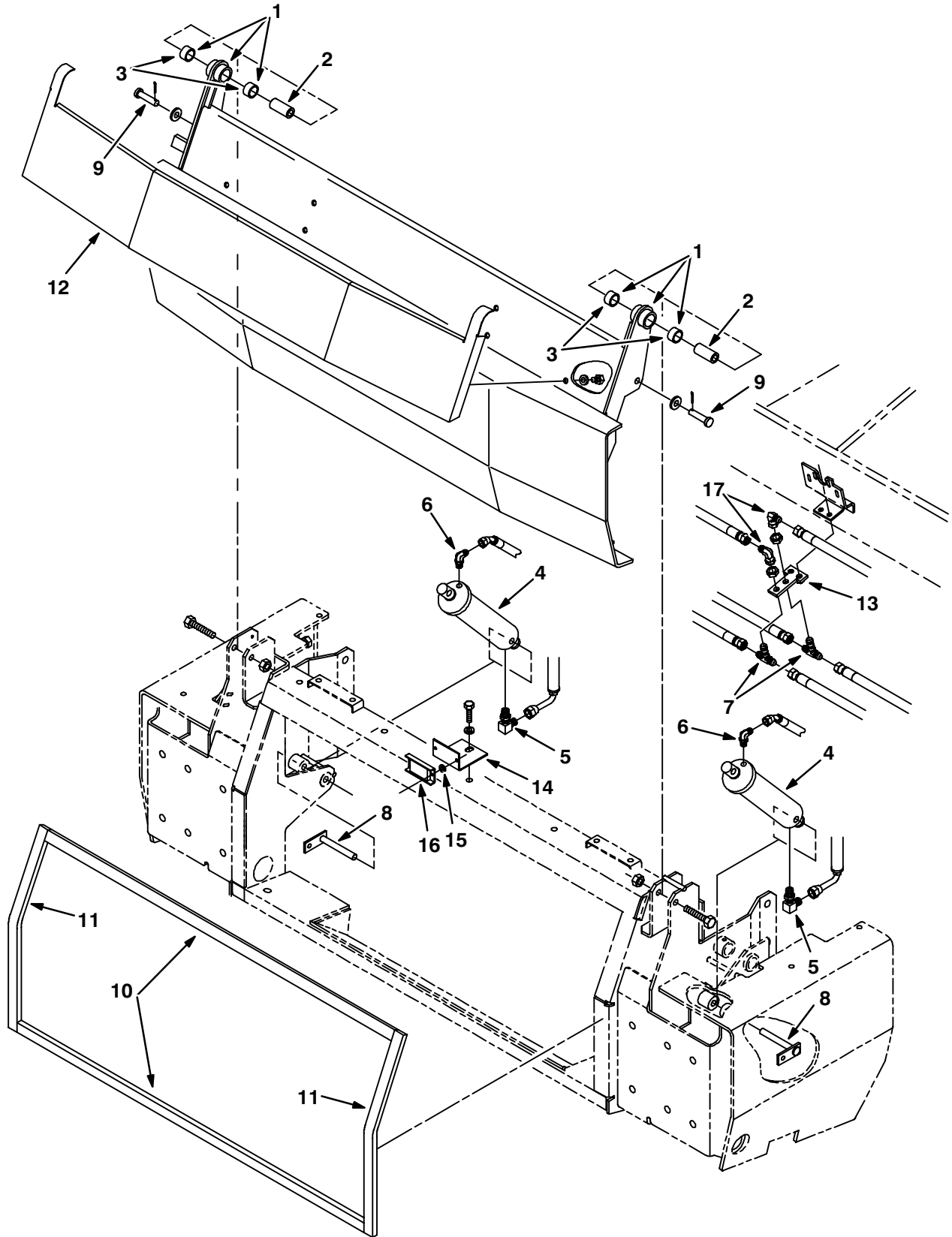

Fig. 20 – Hopper Door Group

Ref.	Tennant Part No.	Machine Serial Number	Description	Qty.
1	64232	(000000-001130)	Door Wldt, Hopper	1
2	65302	(000000-001130)	Sleeve, .531B .99D1 .75 Stl	2
3	35688	(000000-001130)	Bearing, Journal	4
4	63589	(000000-001130)	Cylinder, Hyd	2
5	77097	(000000-001130)	Ftg-Hyd E90 Jm04/Om04	2
6	82825	(000000-001130)	Ftg-Hyd E90 Jm04/Om04	2
7	34392	(000000-001130)	Ftg-Hyd Tee Jm04Jmjm	2
8	64893	(000000-001130)	Pin	2
9	11211	(000000-001130)	Pin, Clevis .50 Dia X 2.25 Lg	2
10	70854	(000000-001130)	Seal, Urethane	2
11	70855	(000000-001130)	Seal, Urethane	2
12	65287	(000000-001130)	Panel, Hopper Door	1
13	75012	(000000-001130)	Bracket, Mtg, Ftg	1
14	75852	(000000-001130)	Bracket, L	1
15	63416	(000000-001130)	Washer, .310B .88D .12Rbr	2
16	63378	(000000-001130)	Magnet	1
17	39210	(001055-001130)	Ftg-Hyd E90 Jm04/Jf04	2

Fig. 21 – Hopper Door Group

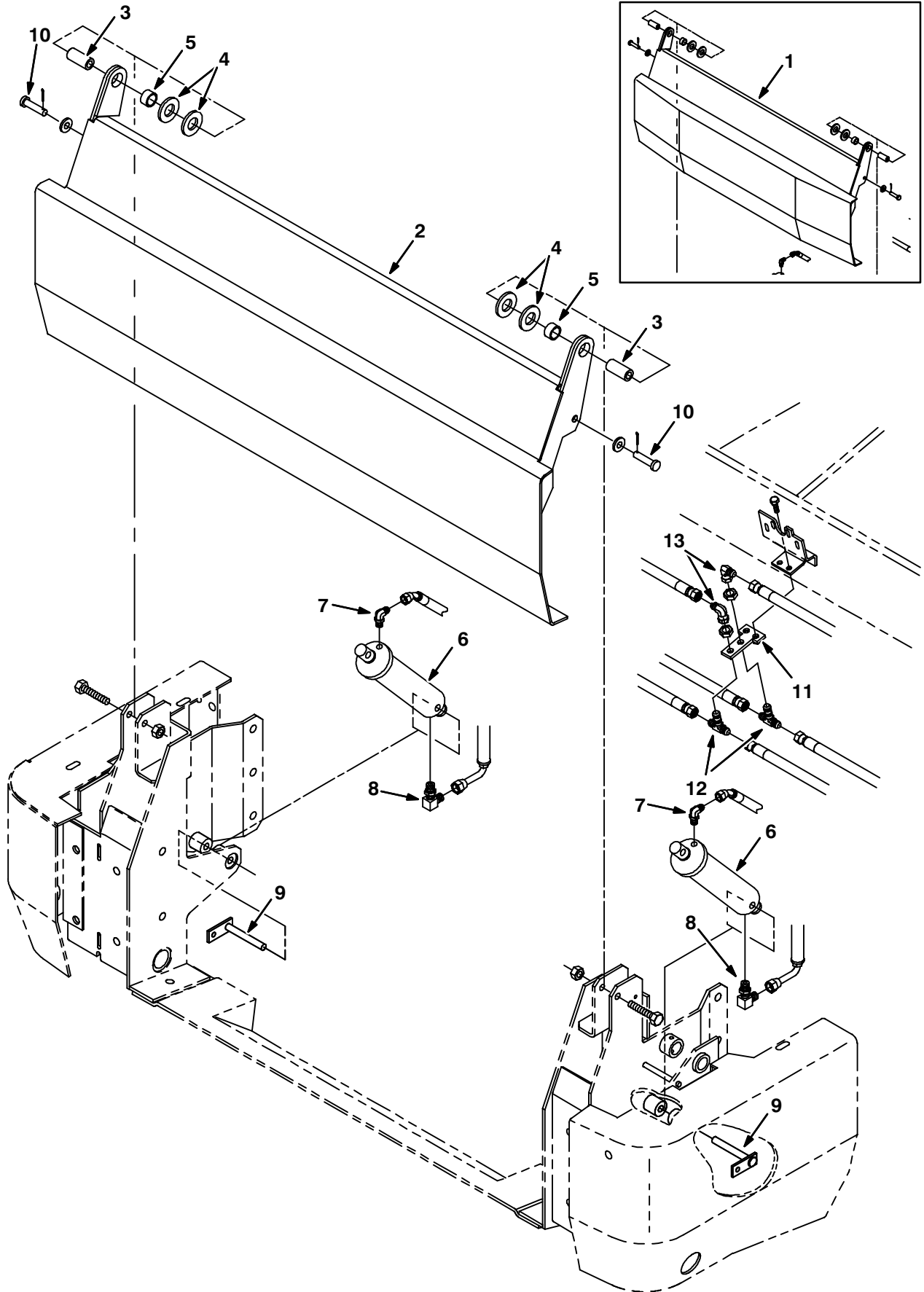

Fig. 21 – Hopper Door Group

Ref.	Tennant Part No.	Machine Serial Number	Description	Qty.
1	76936	(001131-001258)	Door Wldt, Hopper	1
2	76529	(001259-001699)	Door Wldt, Hopper	1
2	83618	(001700-)	Door Wldt, Hopper	1
3	79138	(001131-)	Sleeve, Pivot, Door	2
4	79596	(001131-)	Washer, 1.015B 1.75D .11Hrs	4
5	35688	(001131-)	Bearing, Journal	2
6	21721	(001131-)	Cylinder, Hyd 2.0B 8.0S 2500	2
7	82825	(001131-)	Ftg-Hyd E90 Jm04/Om04	2
8	77097	(001131-)	Ftg-Hyd E90 Jm04/Om04	2
9	64893	(001131-)	Pin	2
10	21722	(001131-)	Pin, Clevis .50 Dia X 2.25 Lg	2
11	75012	(001131-)	Bracket, Mtg, Ftg	1
12	34392	(001131-)	Ftg-Hyd Tee Jm04Jmjim	2
13	39210	(001131 -)	Ftg-Hyd E90 Jm04/Jf04	2

Fig. 22 – Hopper Cover Group

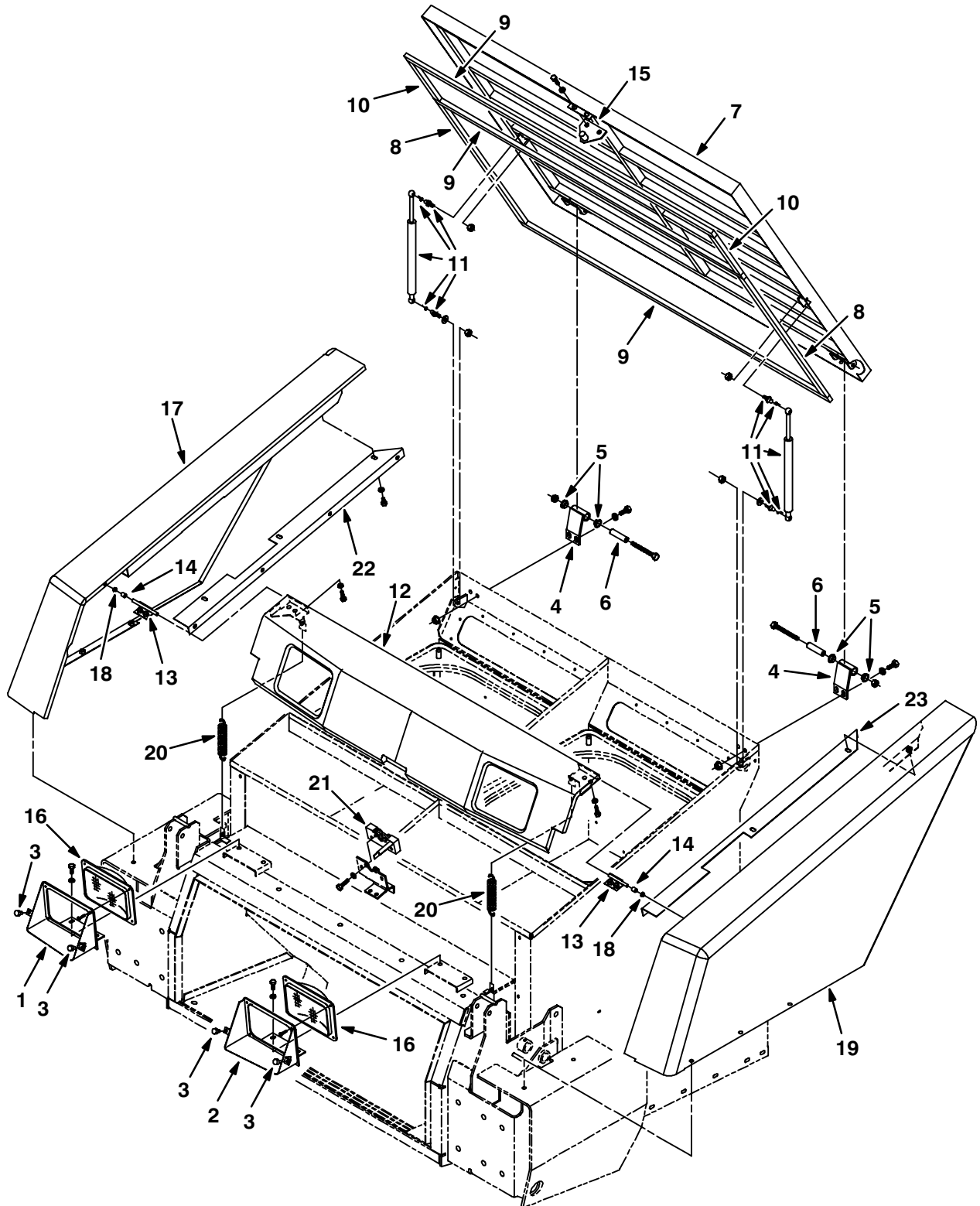

Fig. 22 – Hopper Cover Group

Ref.	Tennant Part No.	Machine Serial Number	Description	Qty.
1	65290	(000000-001130)	Bracket Wldt, Mtg,Headlamp,Rh (Replaced by 77388)	1
2	70472	(000000-001130)	Bracket Wldt, Mtg,Headlamp,Lh (Replaced by 77388)	1
3	51787	(000000-001211)	Bumper, Rubber	4
4	70762	(000000-001211)	Hinge Wldt	2
5	04843	(000000-001211)	Bearing, Flange .625 Bore	4
6	70761	(000000-001211)	Tube, 0.62D .44B 2.44,Stl	2
7	70595	(000000-001211)	Cover Assy, Hopper	1
8	70851	(000000-001211)	Seal, Urethane	3
9	70852	(000000-001211)	Seal, Urethane	2
10	70853	(000000-001211)	Seal, Urethane	2
11	69906	(000000-001211)	Spring-Gas Assy	2
12	65285	(000000-001130)	Panel Wldt, Headlight	1
13	70730	(000000-001211)	Hinge Wldt	2
14	74015	(000000-001211)	Sleeve, .320B .32D .49 Lc Stl	2
15	70742	(000000-001211)	Pin Wldt, Latch	1
16	58524	(000000-001211)	Headlight, 12V.Rect.	2
17	65278	(000000-001211)	Panel Wldt, Fender, Rh	1
18	11747	(000000-001211)	Bearing, Nylon	2
19	65281	(000000-001211)	Panel Wldt, Fender, Lh	1
20	01274	(000000-001211)	Sprng,Tens,0.965Odx.09Wire4.4L	2
21	59195	(000000-001211)	Latch, Hook, Rh	1
22	75047	(000000-001211)	Bracket, R. H.	1
23	75046	(000000-001211)	Bracket, L. H.	1

Fig. 23 – Hopper Cover Group

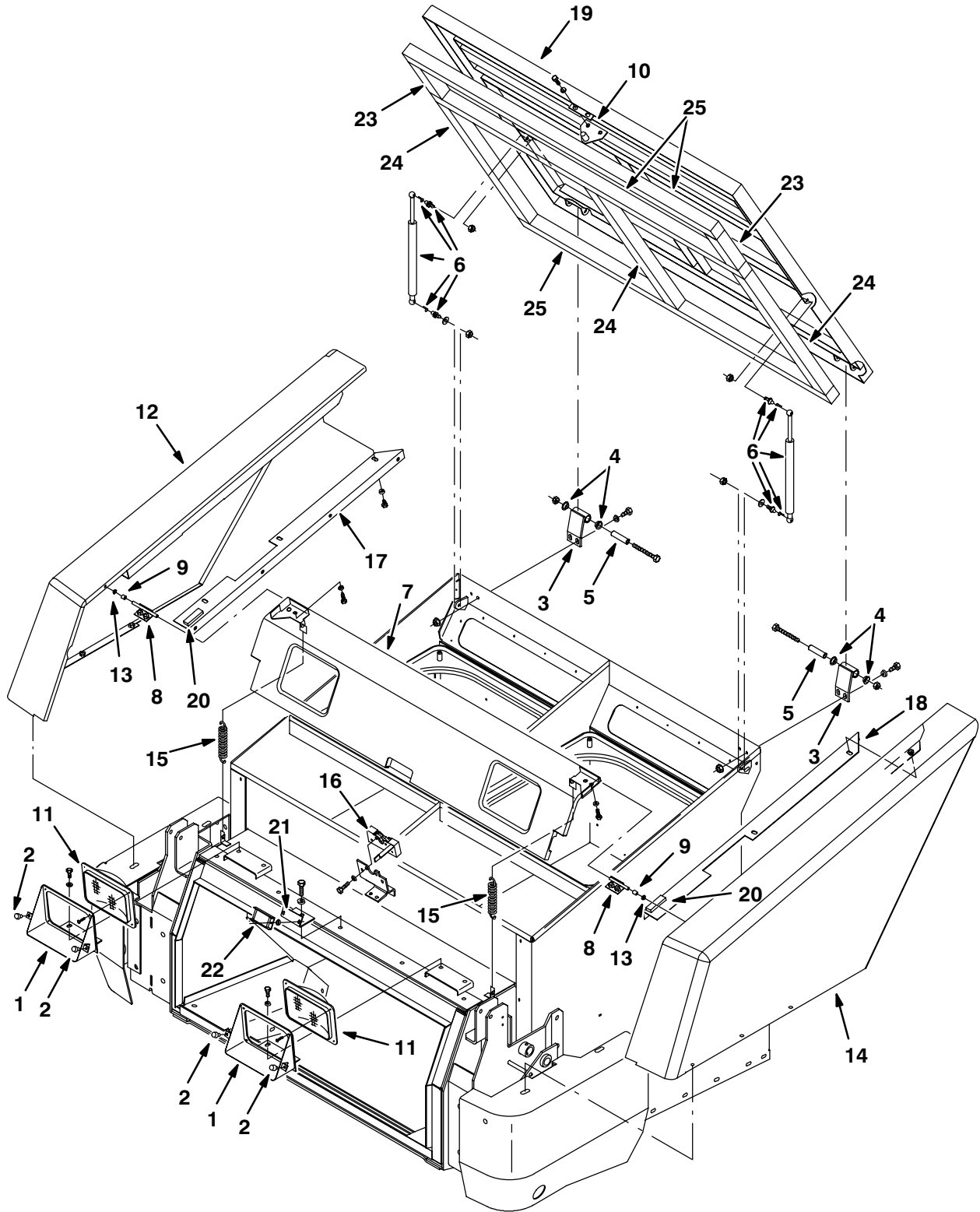

Fig. 23 – Hopper Cover Group

Ref.	Tennant Part No.	Machine Serial Number	Description	Qty.
1	77388	(001131-) Bracket, Mounting, Headlamp	2
2	51787	(001212-) Bumper, Rubber	4
3	70762	(001212-) Hinge	2
4	04843	(001212-) Bearing, Flange .625 Bore	4
5	70761	(001212-) Tube, 0.62D .44B 2.44, Stl	2
6	69906	(001212-) Spring-Gas, Engine Cover	2
7	77394	(001131-) Panel, Headlight	1
8	70730	(001212-) Hinge	2
9	74015	(001212-) Sleeve, .320B .32D .49 Lc Stl	2
10	70742	(001212-) Pin Wldt, Latch	1
11	58524	(001212-) Headlight, 12V.Rect.	2
12	65278	(001212-) Panel Wldt, Fender, Rh	1
13	11747	(001212-) Bearing, Nylon	2
14	65281	(001212-) Panel Wldt, Fender, Lh	1
15	01274	(001212-) Sprng,Tens,0.965Odx.09Wire4.4L	2
16	79019	(001212-) Latch, Hook, Rh, Single Catch	1
17	75047	(001212-) Bracket, Rh	1
18	75046	(001212-) Bracket, Lh	1
19	79587	(001212-001383) Cover Assy, Hopper	1
19	21221	(001384-) Cover Assy, Hopper	1
20	79591	(001212-) Bumper, Cover, Hopper	2
21	77400	(001131-) Angle, Mount	1
22	63378	(001212-) Magnet, Drive Brush	1
23	77390	(001212-) Seal, Urethane Covered Foam	2
24	77391	(001212-) Seal, Urethane Covered Foam	3
25	77392	(001212-) Seal, Urethane Covered Foam	3

Fig. 24 – Hopper Bumper Group

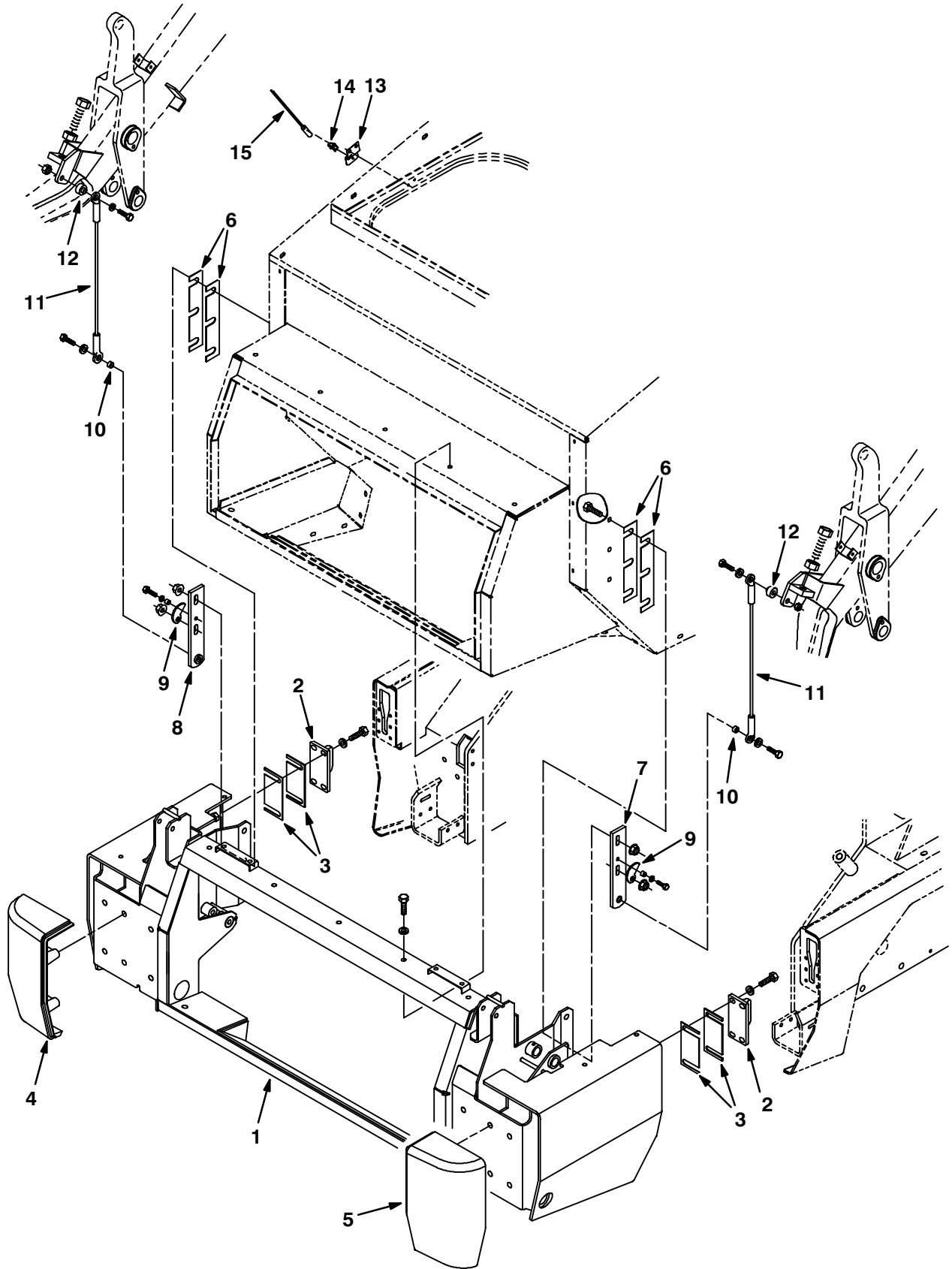

Fig. 24 – Hopper Bumper Group

Ref.	Tennant Part No.	Machine Serial Number	Description	Qty.
1	63632	(000000-001184)	Bumper Wldt, Front	1
2	63671	(000000-001184)	Latch, Bumper	2
3	63662	(000000-001184)	Plate, Shim, Bumper, .06 Thk	4
4	63676	(000000-001184)	Bumper, Front, Machining, Rh	1
5	63677	(000000-001184)	Bumper, Front, Machining, Lh	1
6	74070	(000000-001184)	Plate, Shim, Hopper	4
7	74867	(000000-001102)	Plate Wldt, Link, Lh	1
8	74868	(000000-001102)	Plate Wldt, Link, Rh	1
9	75667	(000000-001102)	Cam, Adjuster	2
10	40282	(000000-001102)	Sleeve, .370B .50D .38 Cd.Znc	2
11	70532	(000000-001102)	Cable, Retaining	2
12	70528	(000000-001102)	Spacer	2
13	75827	(000000-001102)	Bracket, Mtg, Switch	1
14	40131	(000000-001102)	Clip, Mercury Switch	1
15	75843	(000000-001102)	Switch Assy, Hopper, Angle	1

Fig. 25 – Hopper Bumper Group

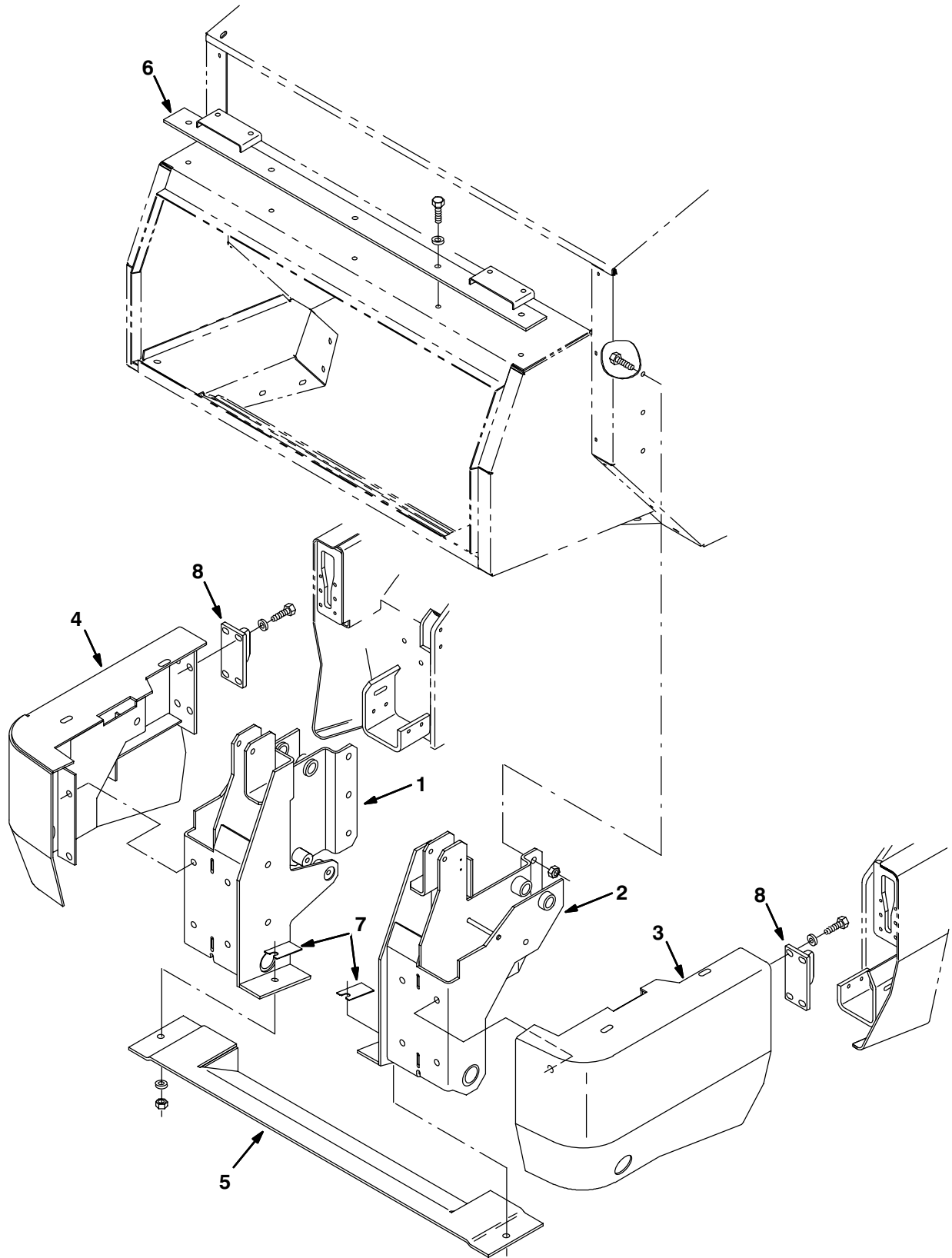

Fig. 25 – Hopper Bumper Group

Ref.	Tennant Part No.	Machine Serial Number	Description	Qty.
1	76895	(001185-001699)	Bumper Wldt, Front, Rh	1
1	83547	(001700-)	Bumper Wldt, Sppt, Hopper, Rh	1
2	77479	(001185-001699)	Support Wldt, Hopper Lh	1
2	83548	(001700-)	Support Wldt, Sppt, Hopper Lh	1
3	77482	(001185-001699)	Bumper Wldt, Lh	1
3	83620	(001700-)	Bumper Wldt, Lh	1
4	76871	(001185-001699)	Bumper Wldt, Rh	1
4	83622	(001700-)	Bumper Wldt, Rh	1
5	77523	(001185-)	Guard Wldt, Hopper	1
6	77516	(001185-)	Bracket Wldt, Mtg, Headlight	1
7	79181	(001185-)	Shim	2
8	63671	(001185-)	Latch, Bumper	2

Fig. 26 – Filter Shaker Group

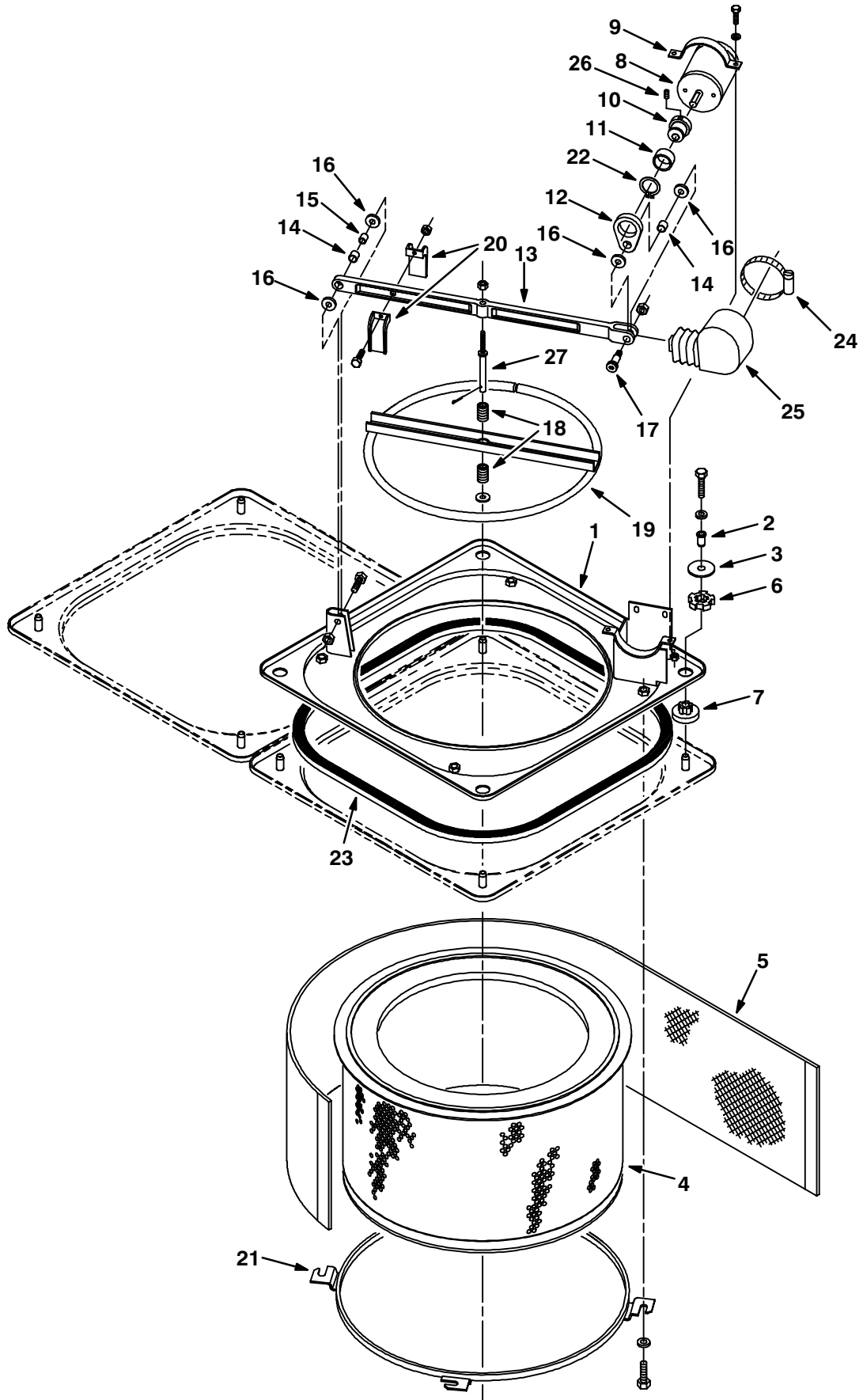

Fig. 26 – Filter Shaker Group

Ref.	Tennant Part No.	Machine Serial Number	Description	Qty.
1	64580	(000000–)	Panel Wldt, Shaker	2
2	64874	(000000–)	Ferrule	8
3	64873	(000000–)	Disc	8
▽ 4	63297	(000000–)	Filter Assy	2
△ 5	63311	(000000–)	Screen, Filter	1
6	64618	(000000–)	Ring, Isolator, Outer, Rbr	8
7	64621	(000000–)	Bushing, Isolator	8
8	31999	(000000–)	Motor, Electric, 13.6 Vdc	2
9	64559	(000000–)	Clamp, Mtg, Motor, Upper	2
10	64567	(000000–)	Shaft, Eccentric	2
11	32006	(000000–)	Bearing	2
12	64394	(000000–)	Link, Eccentric	2
▽ 13	77471	(000000–)	Shaker Bar Replacement Kit	2
△ 14	63233	(000000–)	Bearing, Fiberglide .50 X .50	2
△ 15	63234	(000000–)	Sleeve, Bearing	1
△ 16	59633	(000000–)	Bearing, Thrust – Fiberglide	4
△ 17	58357	(000000–)	Shoulder Screw	2
18	64392	(000000–)	Spring	4
19	64501	(000000–)	Ring Wldt, Shaker	2
20	64410	(000000–)	Guide	4
21	64500	(000000–)	Ring Wldt, Mtg, Filter	2
22	70651	(000000–)	Ring, Retaining, Ext 1.12	2
23	21303	(000000–)	Seal Kit, Shaker Panel	2
24	43555	(000000–)	Clamp–Wormdrive, 1.62– 3.50D	2
25	73734	(000000–)	Seal, Dust	2
26	70650	(000000–)	Set Screw	2
27	32009	(000000–)	Bar, Shaker Stem	2

Fig. 27 – Pressure Switch Group

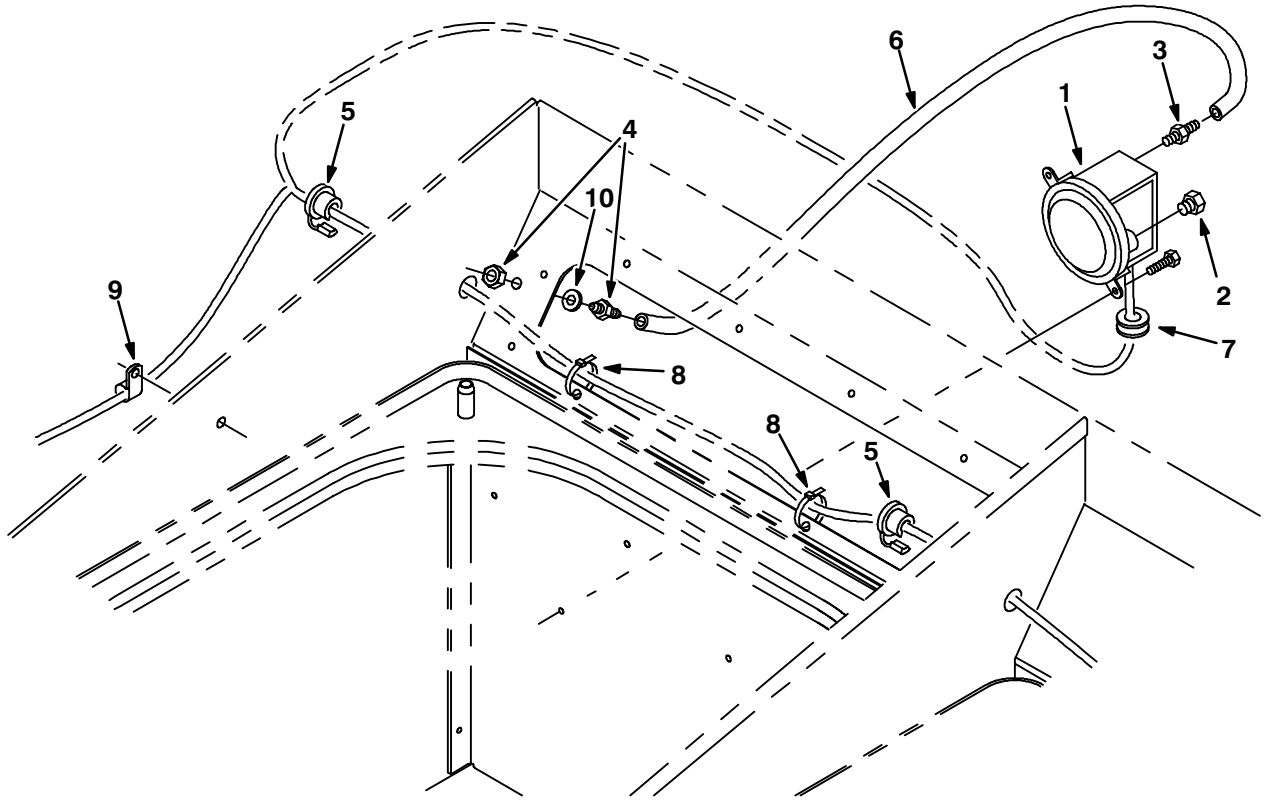

Fig. 27 – Pressure Switch Group

Ref.	Tenant Part No.	Machine Serial Number	Description	Qty.
1	75465	(000000–) Switch, Pressure	1
2	82739	(000000–) Ftg, Breather	1
3	40607	(000000–) Ftg–Brs Str Bm03/Pm02	1
4	39923	(000000–) Ftg,Bulkhead–Barb Wh 1074X4	1
5	34864	(000000–) Strain,Relief	2
6	73727	(000000–) Hose, Vac, Rubber	1
7	10632–4	(000000–) Grommet,Rbr,0.62ld,For .06Matl	1
8	49266	(000000–) Tie, Cable 1.75D Max 7.50Lg	4
9	26395–1	(000000–) Clamp–Cable, 0.56Dia 0.38Wth	2
10	43454	(000000–) Washer	1

Fig. 28 – Engine and Mount Group

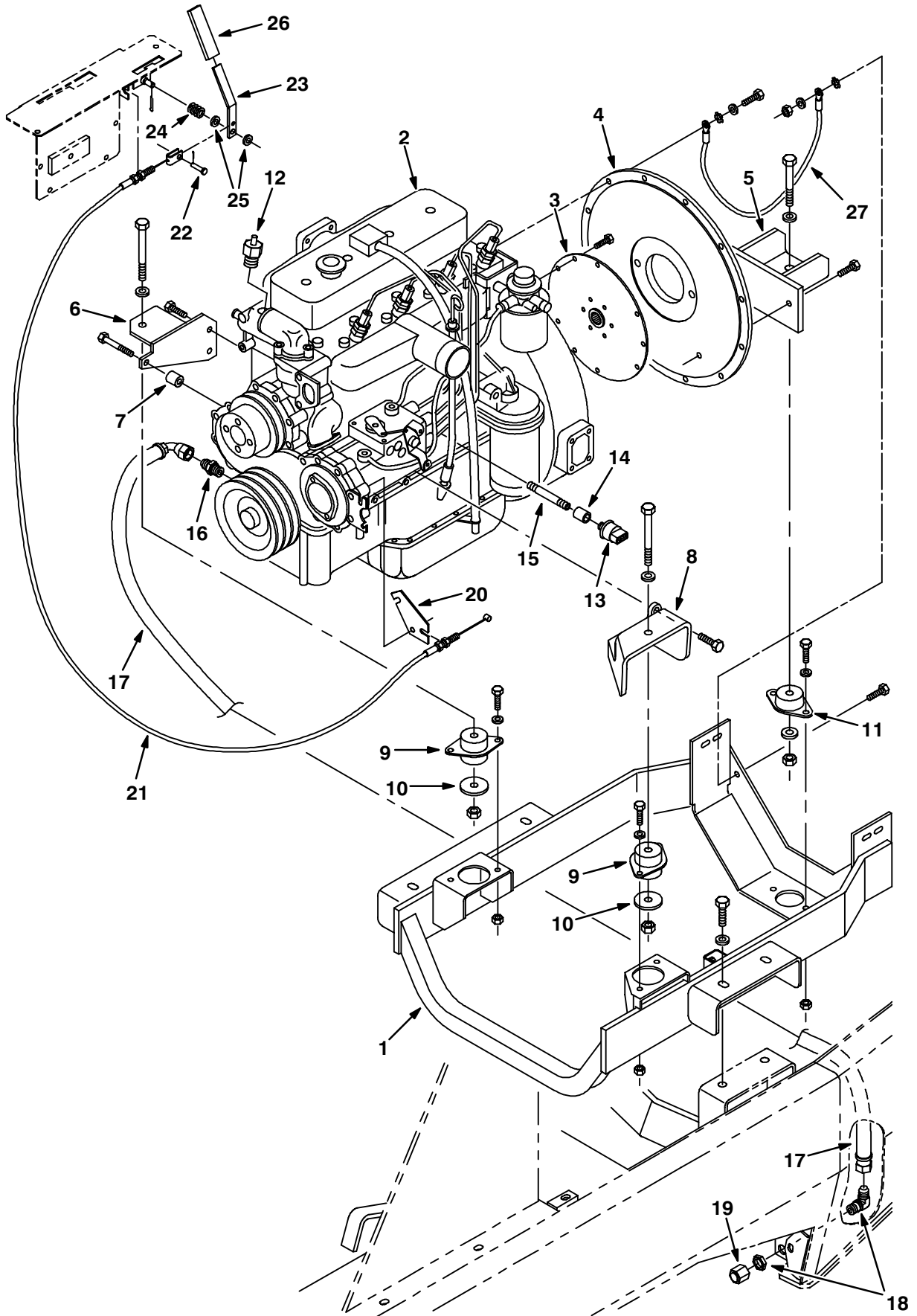

Fig. 28 – Engine and Mount Group

Ref.	Tennant Part No.	Machine Serial Number	Description	Qty.
1	62969	(000000-001223)	Cradle Wldt, Engine, Diesel	1
2	64436	(000000-001223)	Engine,Basic-Perkins, 4.154 (See Engine Breakdown)	1
3	35980	(000000-001223)	Coupling Assy, Flywheel	1
4	63693	(000000-001223)	Plate, Mtg, Pump, Machining	1
5	63535	(000000-001223)	Channel Wldt, Mtg, Engine,Rear	1
6	64097	(000000-001223)	Plate Wldt, Mtg, Die	1
7	65099	(000000-001223)	Spacer	1
8	64098	(000000-001223)	Bracket, Mtg, Motor	1
9	75768	(000000-001223)	Isolator	2
10	57048	(000000-001223)	Washer, .532B 2.13D .11Hr.Znc	2
11	63695	(000000-001223)	Isolator, Mtg	1
12	33875	(000000-001223)	Send Unit, Temperature, Water	1
13	55838	(000000-001223)	Switch, Pressure, Oil	1
14	11848	(000000-001223)	Ftg,Pipe,Cplg.Full 0.13Pt.Blk	1
15	11847	(000000-001223)	Ftg,Pipe,Nip.Blk0.12Ptx 4.00Lg	1
16	12976	(000000-001223)	Ftg-Metric Str Omm14/Jm08	1
17	73798	(000000-001223)	Hose-Hyd Low08 Jf/J9	1
18	34365	(000000-001223)	Ftg-Hyd E90 Jm08/Jm08	1
19	60090	(000000-001223)	Ftg-Hyd Cap Jf08	1
20	70389	(000000-001223)	Bracket, Throttle Cable, Die	1
21	73799	(000000-001223)	Cable, Throttle	1
22	28296	(000000-001223)	Pin,Clevis,0.25 Dia.X 0.50 Lg	1
23	70752	(000000-001223)	Handle	1
24	69495	(000000-001223)	Sprng,Comp,0.75Od0.09Wire 0.8L	1
25	43611	(000000-001223)	Washer, .375B .75D .06Nylon	2
26	87246	(000000-001223)	Grip Vinyl .18 X .75 X 4.00	1
27	57773	(000000-001223)	Wire Assy., Elect. Ground	1

Fig. 29 – Engine and Mount Group

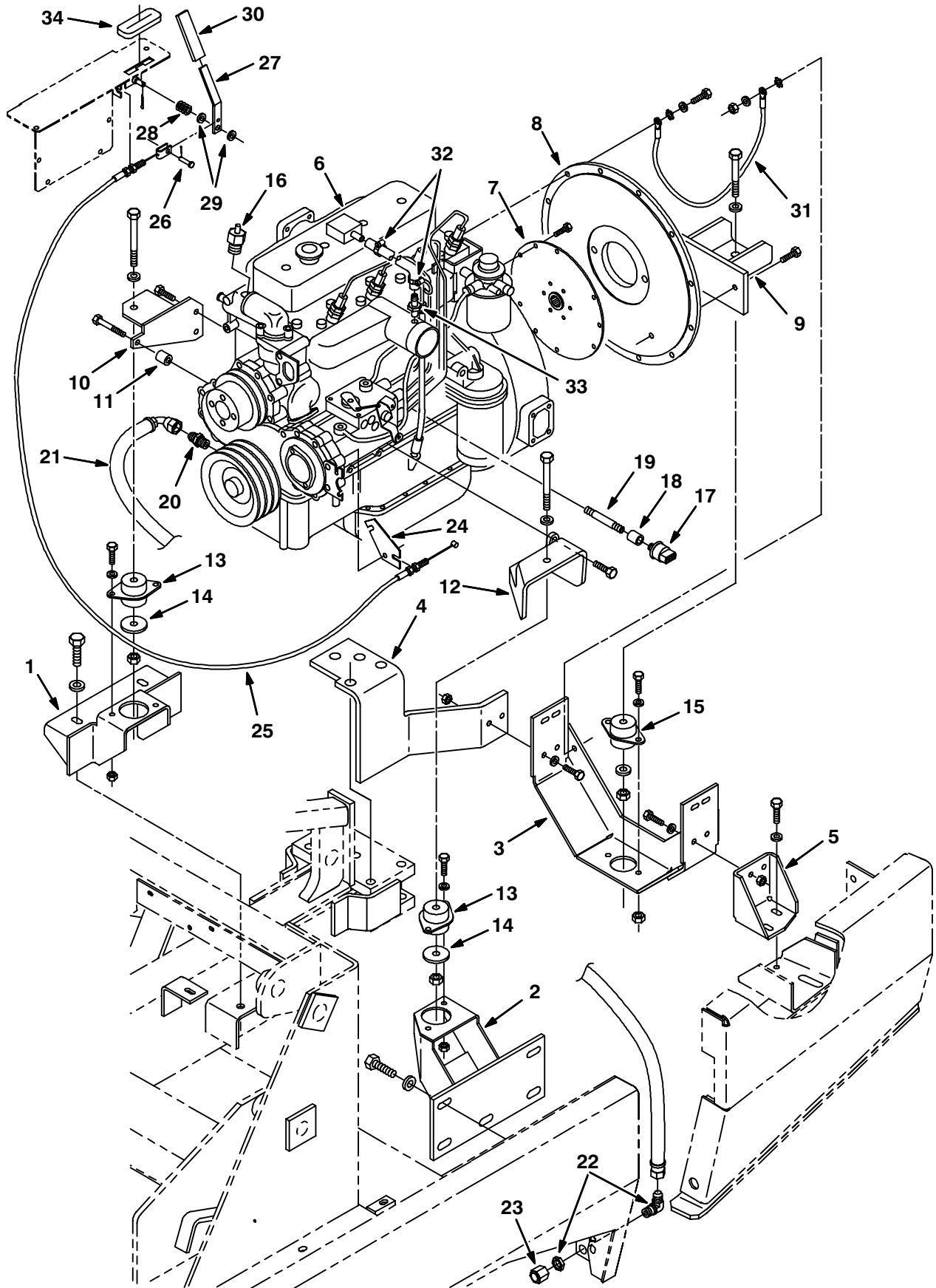

Fig. 29 – Engine and Mount Group

Ref.	Tennant Part No.	Machine Serial Number	Description	Qty.
1	77424	(001224–)	Bracket Wldt, Mtg, Die, Rh	1
2	77436	(001224–)	Bracket Wldt, Mtg, Die, Lh	1
3	77430	(001224–)	Bracket, Mounting, Eng, Rear	1
4	77435	(001224–)	Bracket, Mtg, Engine, Rear	1
5	77434	(001224–)	Bracket, Mounting, Eng,Rear Lh	1
6	64436	(001224–)	Engine, Basic–4.154	1
7	35980	(001224–)	Coupling Flywheel	1
8	63693	(001224–)	Plate, Mounting, Pump,	1
9	63535	(001224–)	Channel Wldt, Mtg, Engine,Rear	1
10	64097	(001224–)	Plate, Mounting Die	1
11	65099	(001224–)	Spacer	1
12	64098	(001224–)	Bracket, Mounting, Motor	1
13	75768	(001224–)	Isolator	2
14	57048	(001224–)	Washer, .532B 2.13D .11Hr.Znc	2
15	63695	(001224–)	Isolator, Mounting	1
16	33875	(001224–)	Sending Unit,Water Temperature	1
17	79399	(001224–)	Switch, Pressure, Oil	1
18	11848	(001224–)	Ftg,Pipe,Cplg.Full 0.13Pt.Blk	1
19	11847	(001224–)	Ftg,Pipe,Nip.Blk0.12Ptx 4.00Lg	1
20	12976	(001224–)	Ftg–Hyd Str Mom14/Jm08	1
21	73798	(001224–)	Hose–Hyd Low08 See60108 Jf/J9	1
22	34365	(001224–)	Ftg–Hyd E90 Jm08/Jm08	1
23	60090	(001224–)	Ftg–Hyd Cap Jf08	1
24	70389	(001224–)	Bracket, Throttle Cable, Die	1
25	73799	(001224–)	Cable, Throttle	1
26	14605	(001224–)	Pin,Clevis,0.25 Dia.X 0.75 Lg	1
27	70752	(001224–)	Handle	1
28	69495	(001224–)	Spring, Comp.75Od0.09Wire 0.8L	1
29	43611	(001224–)	Washer, .375B .75D .06Nylon	2
30	87246	(001224–)	Grip Vinyl .18 X .75 X 4.00	1
31	57773	(001224–)	Wire Ass'Y–Elect.,Ground	1
32	54333	(001224–)	Clamp–Wormdrive, 0.31– 0.88D	2
33	77481	(001224–)	Fitting, Brs Spcl	1
34	77789	(001224–)	Seal, Throttle Handle, Die	1

Fig. 30 – Alternator Group

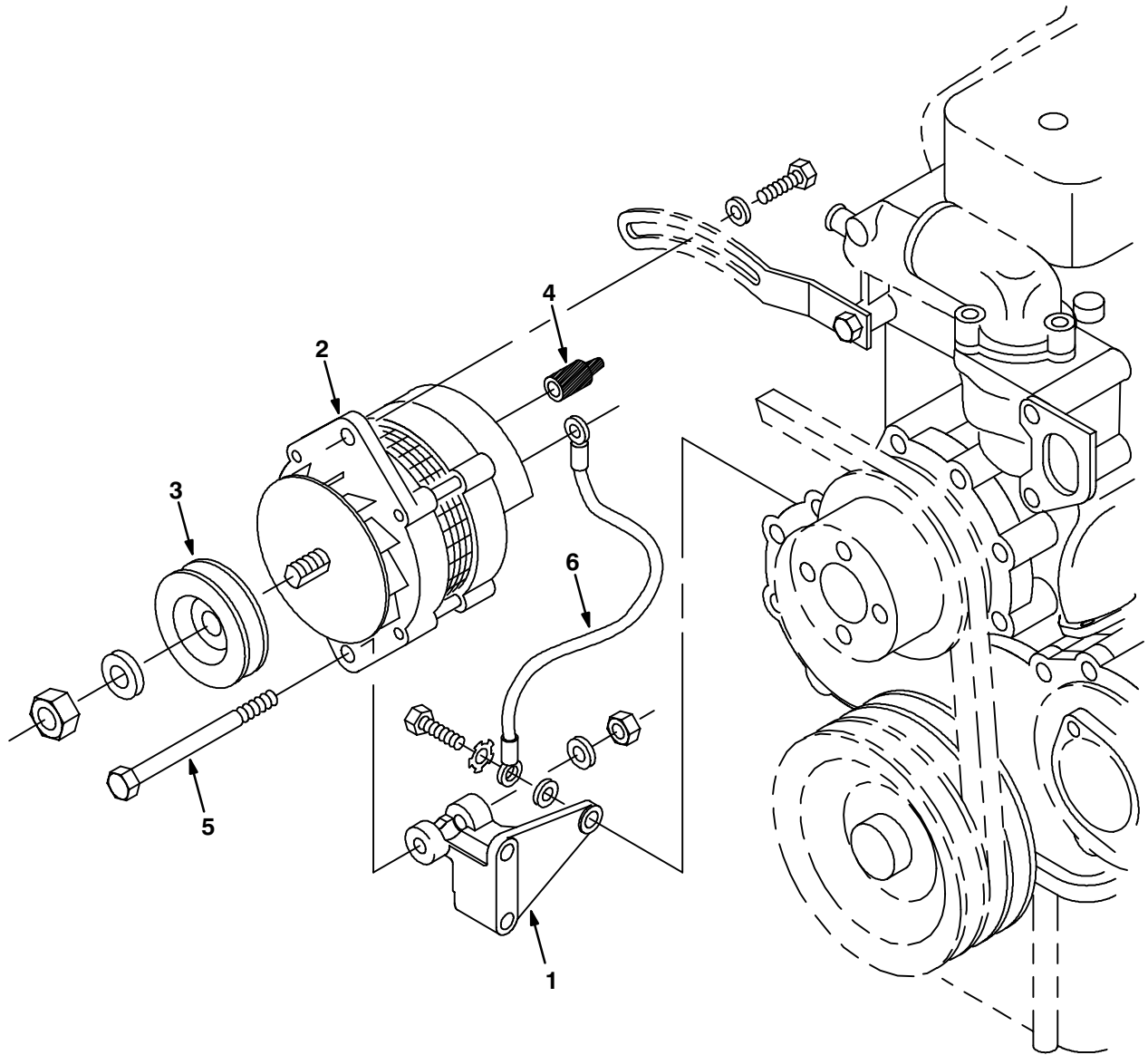

Fig. 30 – Alternator Group

Ref.	Tennant Part No.	Machine Serial Number	Description	Qty.
1	64942	(000000–) Bracket, Alternator, Machined	1
2	60559	(000000–) Alternator, 50A, Sealed Brushes	1
3	64692	(000000–) Sheave, Alternator, Die	1
4	61363	(000000–) Boot, Alternator	2
5	39231	(000000–) Scr–Hex .38–16X5.00 G5 Pltd	1
6	82731	(001032–) Wire Ground, Alternator	1
	60714	(000000–) Belt, V	1

Fig. 31 – Air Cleaner Group

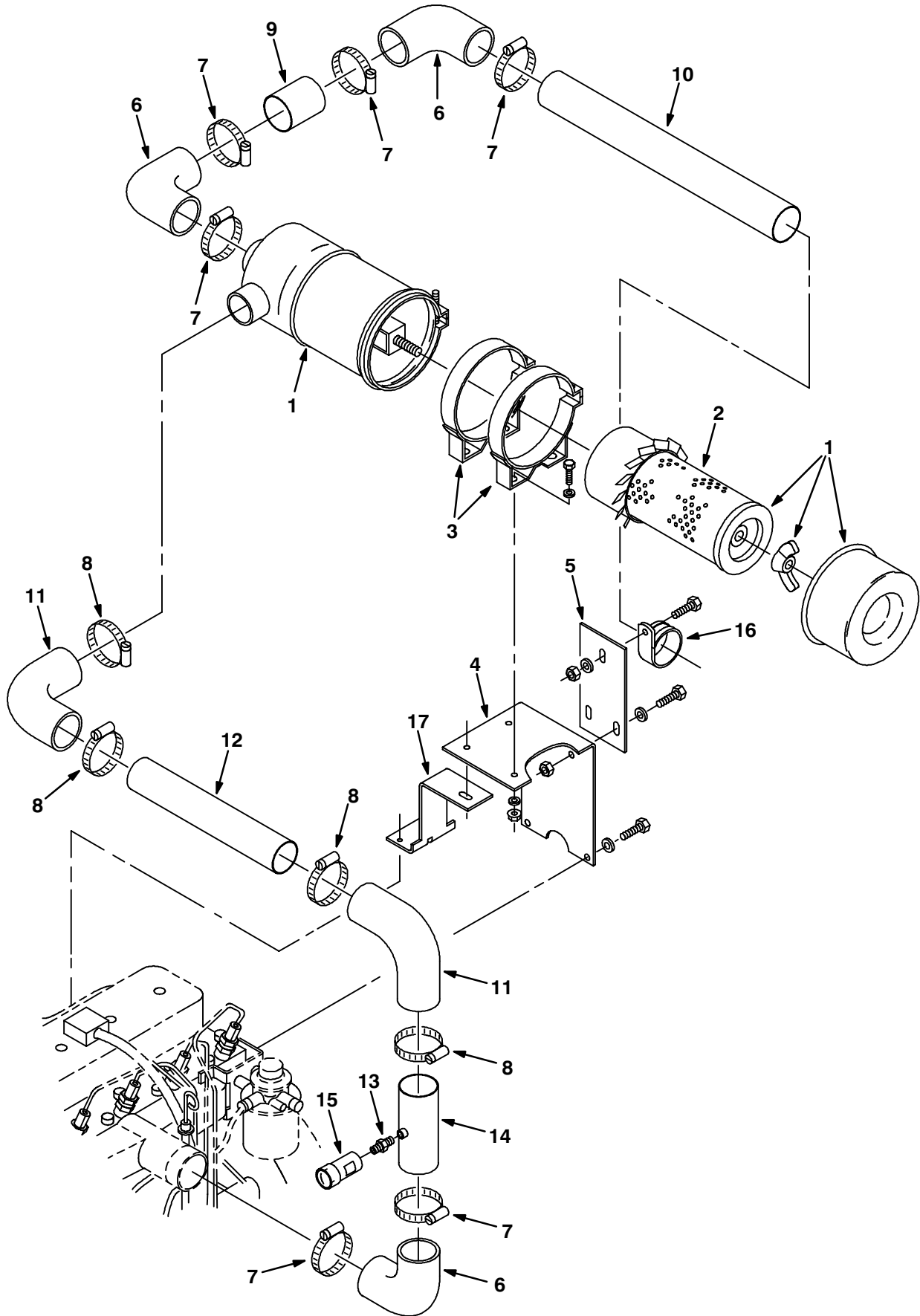

Fig. 31 – Air Cleaner Group

Ref.	Tennant Part No.	Machine Serial Number	Description	Qty.
∇ 1	76319	(000000-001140)	Air Cleaner	1
2	76335	(000000-001140)	Element Assy	1
3	76321	(000000-001140)	Band,Mtg.	2
4	70833	(000000-001140)	Bracket, Mtg, Air Cleaner	1
5	73784	(000000-001140)	Bracket	1
6	16497	(000000-001140)	Elbow-Rubber,90Deg,2.5I.D.	3
7	43555	(000000-001140)	Clamp-Wormdrive, 1.62- 3.50D	6
8	14432	(000000-001140)	Clamp-Wormdrive, 1.81- 2.75D	4
9	70838	(000000-001140)	Tube, Air Cleaner	1
10	73794	(000000-001140)	Tube, 2.50D 2.380 21.0,Stl	1
11	52580-2	(000000-001140)	Elbow,90,Rubber 2.25Dia	2
12	70835	(000000-001140)	Tube, Air Cleaner, Die	1
13	51560-5	(000000-001140)	Filter,Service Indicator	1
14	70836	(000000-001140)	Tube Wldt, Air Cleaner	1
15	03026	(000000-001140)	Adapter, Filter 1/8 Npt	1
16	73735	(000000-001140)	Clamp, Cable	1
17	74020	(000000-001140)	Bracket, Air Cleaner, Die	1

Fig. 32 – Air Cleaner Group

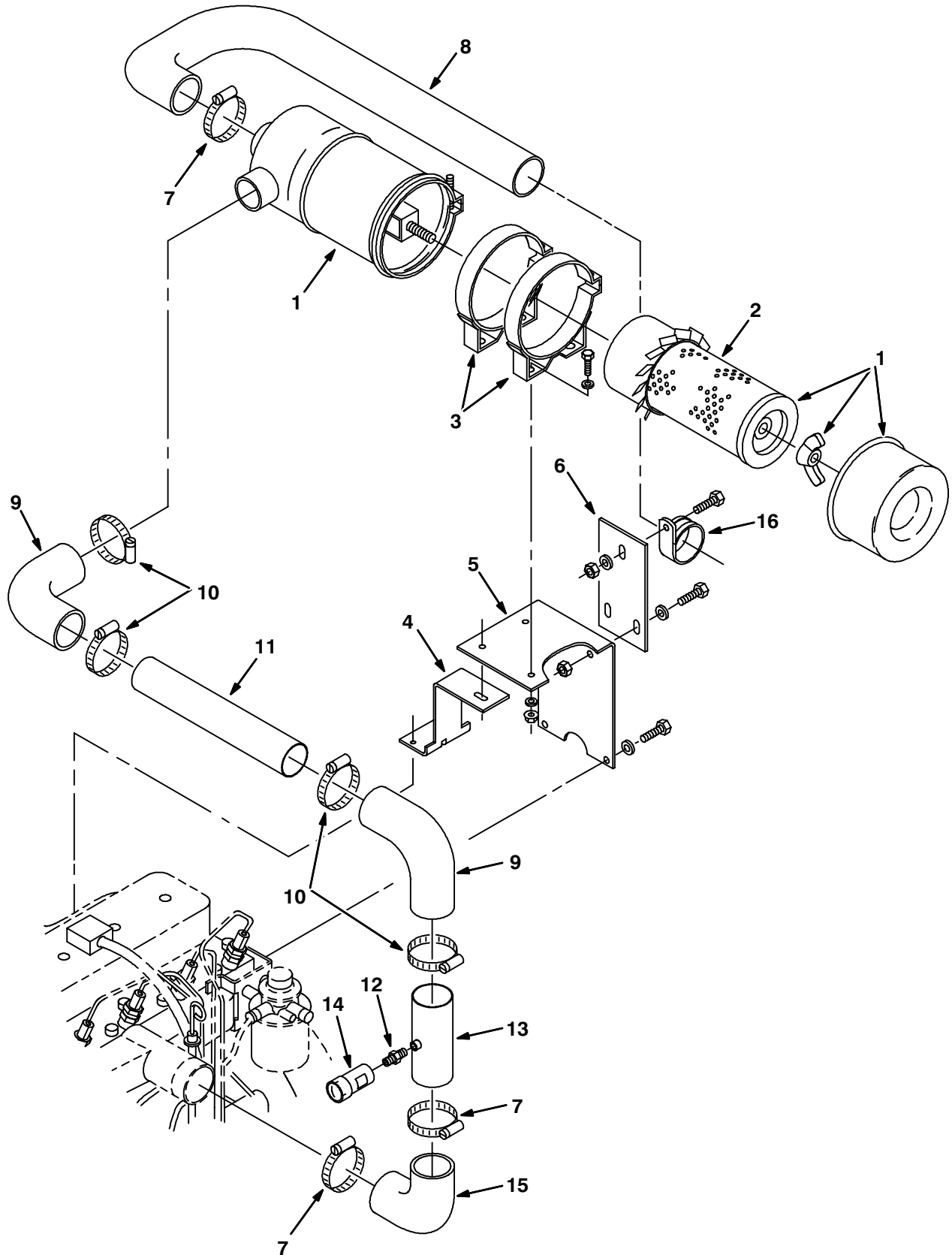

Fig. 32 – Air Cleaner Group

Ref.	Tennant Part No.	Machine Serial Number	Description	Qty.
∇ 1	76319	(001141–)	Air Cleaner	1
2	76335	(001141–)	Element Assy	1
3	76321	(001141–)	Band,Mtg.	2
4	74020	(001141–)	Bracket, Air Cleaner, Die	1
5	70833	(001141–)	Bracket, Mtg, Air Cleaner	1
6	73784	(001141–)	Bracket	1
7	43555	(001141–)	Clamp–Wormdrive, 1.62– 3.50D	3
8	76620	(001141–)	Hose, Molded, Air Intake	1
9	52580–2	(001141–)	Elbow,90,Rubber 2.25Dia	2
10	14432	(001141–)	Clamp–Wormdrive, 1.81– 2.75D	4
11	70835	(001141–)	Tube, Air Cleaner, Die	1
12	51560–5	(001141–)	Adaptor, Filter, 1/8 Npt	1
13	70836	(001141–)	Tube Wldt, Air Cleaner	1
14	03026	(001141–)	Indicator Service Air Filter	1
15	16497	(001141–)	Elbow–Rubber,90Deg,2.5I.D.	1
16	78997	(001141–)	Clamp, Cable	1

Fig. 33 – Muffler Group

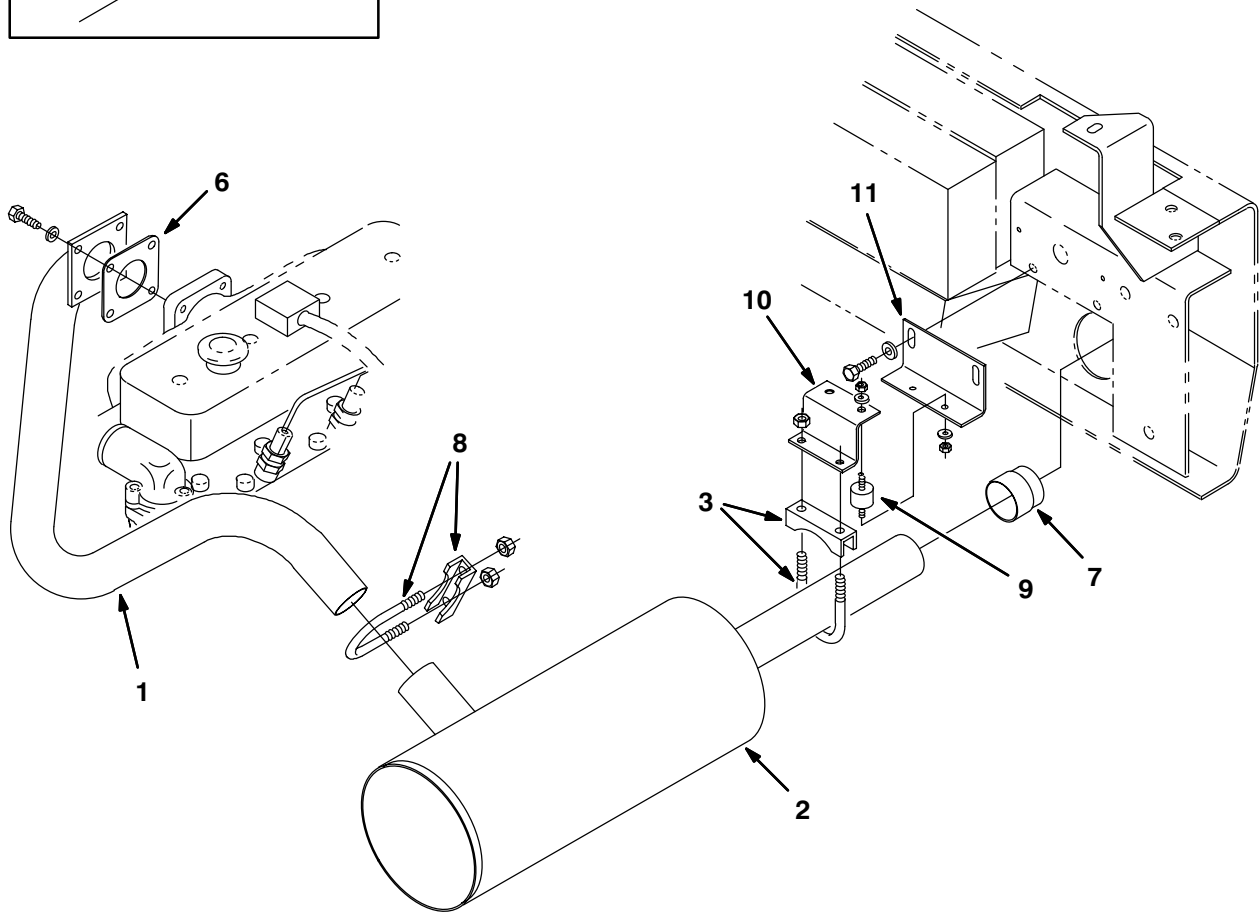
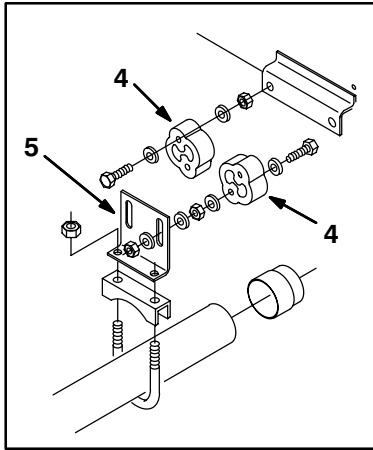

Fig. 33 – Muffler Group

Ref.	Tennant Part No.	Machine Serial Number	Description	Qty.
1	70497	(000000–)	Pipe, Exhaust, Diesel	1
2	76383	(000000–)	Muffler, Exhaust	1
3	05881	(000000–)	Clamp–Muffler,For 2.00 Od Tube	1
4	65158	(000000–001308)	Isolator, Exhaust	2
5	76382	(000000–001308)	Bracket, Tailpipe	1
6	73867	(000000–)	Gasket, Exhaust	1
7	75603	(000000–)	Tube, Extension	1
8	05880	(000000–)	Clamp–Muffler,For 1.87 Od Tube	1
9	82661	(001309–)	Isolator–Vibration .25–20	2
10	21136	(001309–)	Bracket, Tail Pipe	1
11	21138	(001309–)	Bracket, Tail Pipe	1

Fig. 34 – Fuel Tank Group

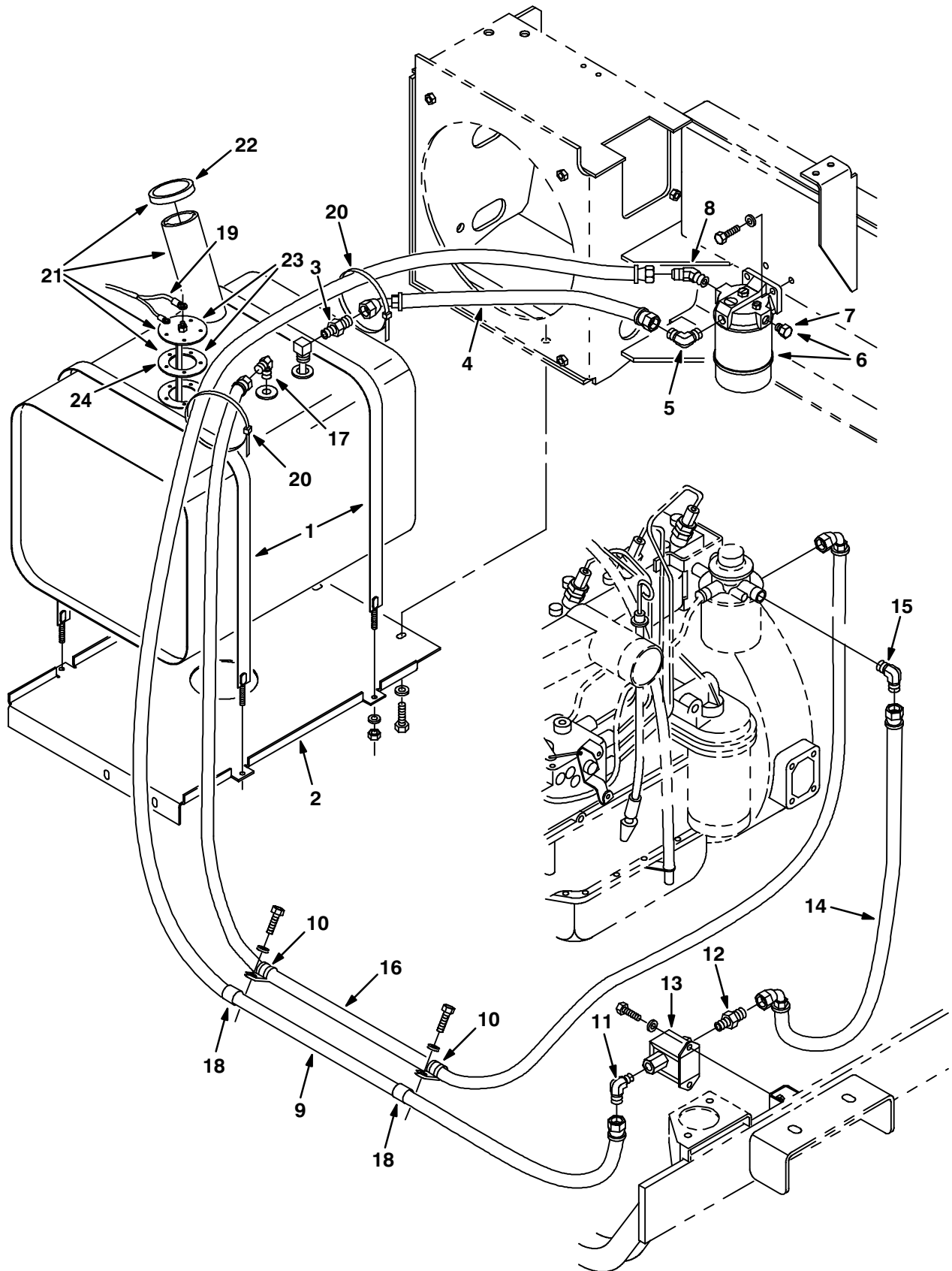

Fig. 34 – Fuel Tank Group

Ref.	Tennant Part No.	Machine Serial Number	Description	Qty.
1	87396	(000000-001117)	Strap, Tank, Gas	2
2	70477	(000000-001117)	Plate, Mtg, Tank, Gas	1
3	15724	(000000-001117)	Ftg-Hyd Str Pm04/Jm06	1
4	57288	(000000-001117)	Hose-Hyd Low06 Jf/J4	1
5	52424	(000000-001117)	Ftg-Hyd E90 Pm04/Jm06	1
▽ 6	82682	(000000-001117)	Filter, Fuel/Water Separator	1
	82692	(000000-001117)	Filter Element,Diesel Fuel	1
7	02247	(000000-001117)	Ftg-Plug Npt 04Pm Hx Soc	1
8	56811	(000000-001117)	Ftg-Hyd E45 Pm04/Jm06	1
9	50955	(000000-001117)	Hose-Hyd Low06 Jf/Jf	1
10	26395-1	(000000-001117)	Clamp-Cable, 0.56Dia 0.38Wth	2
11	45476	(000000-001117)	Ftg-Hyd E90 Pm02/Jm06	1
12	56708	(000000-001117)	Ftg-Hyd Str Pm02/Jm06	1
13	59945	(000000-001117)	Pump, Fuel, Ele	1
14	19653	(000000-001117)	Hose-Hyd Low06 Jf/J9	1
15	49934	(000000-001117)	Ftg-Hyd E90 Pm06/Jm06	1
16	65225	(000000-001117)	Hose-Hyd Low04 Jf/J9	1
17	55455	(000000-001117)	Ftg-Hyd E90 Pm02/Jm04	1
18	67767	(000000-001117)	Clamp-Cable, .69Dia. .62Wth	2
19	70401	(000000-001117)	Harness, Tank, Fuel	1
20	49263	(000000-001117)	Tie, Cable 3.00D Max 11.41Lg	2
▽ 21	63205	(000000-001102)	Tank, Fuel	1
22	48267	(000000-001102)	Cap, Gas	1
▽ 23	07873	(000000-001102)	Send Unit	1
24	14131	(000000-001102)	Gasket, 2.7D 1.5B.12T 5/ 2.1Bc	1

Fig. 35 – Fuel Tank Group

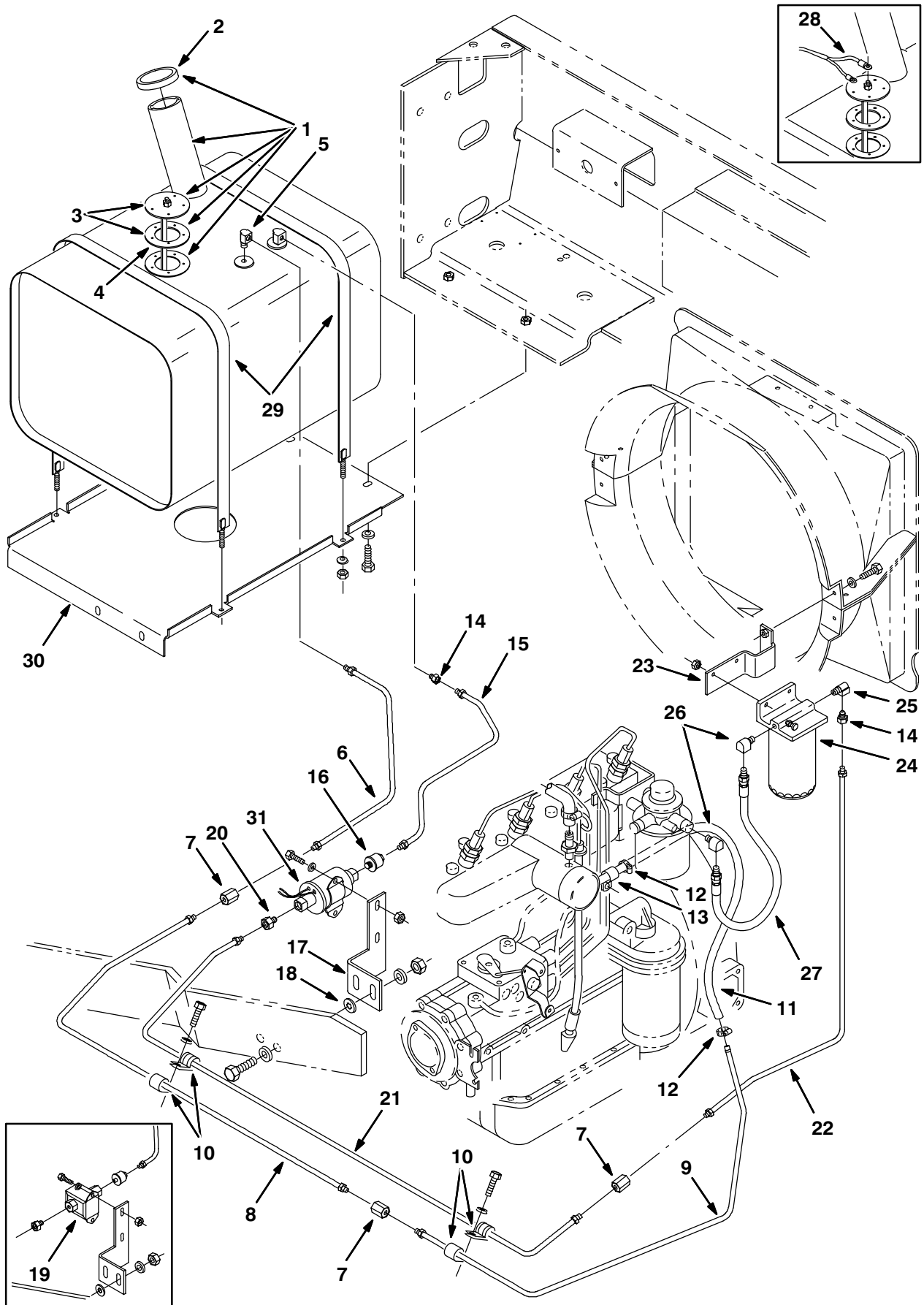

Fig. 35 – Fuel Tank Group

	Ref.	Tennant Part No.	Machine Serial Number	Description	Qty.
∇	1	76907	(001103–)	Tank, Fuel	1
	2	48267	(001103–)	Cap, Fuel	1
∇	3	07873	(001103–)	Send Unit	1
	4	14131	(001103–)	Gasket, 2.7D 1.5B.12T 5/ 2.1Bc	1
	5	15555–1	(001118–)	Ftg–Brs E90 If05/Pm02	1
	6	77559	(001118–)	Fuelline, .312 Od	1
	7	25610	(001118–)	Ftg–Brs If05/If05	3
	8	77556	(001118–)	Fuelline, .312Od	1
	9	77560	(001118–)	Fuelline, .312 Od	1
	10	76736	(001118–)	Clamp–Cable, 0.38Dia 0.62Wth	4
	11	82509	(001118–)	Hose, Fuel Line .31 ldx11.0	1
	12	43844	(001118–)	Clamp–Wormdrive, 0.25– 0.62D	2
	13	67767	(001118–)	Clamp–Cable, .69Dia. 62Wth	1
	14	78043	(001118–)	Fitting–Brs Str	2
	15	77558	(001118–)	Fuelline, .312 Od	1
	16	36050	(001118–)	Filter, Fuel	1
	17	75854	(001118–)	Bracket, Pump, Fuel	1
	18	32491	(001118–)	Washer Flt .31 Hard	2
	19	59945	(001118–001699)	Pump, Fuel, Ele	1
	20	40585	(001118–)	Ftg–Brs Str If05/Pm02	1
	21	77557	(001118–001699)	Fuelline, .312 Od	1
	21	83644	(001700–)	Fuelline, .312 Od	1
	22	77552	(001118–)	Fuelline, .312 Od	1
	23	75855	(001118–)	Bracket, Water Separator	1
∇	24	55850	(001118–)	Filter, Fuel diesel	1
		55844	(001118–)	Filter, Fuel, Element	1
	25	27048	(001118–)	Fitting, El 90Npt/Npt 04Pf	1
	26	15555–2	(001118–)	Fitting, Brass E90	2
	27	77462	(001118–)	Hose, Hyd, Special	1
	28	70401	(001118–001699)	Harness, Tank, Fuel	1
	29	87396	(001118–)	Strap Weldmt, Gas Tank	2
	30	70477	(001118–)	Plate, Mounting, Tank, Gas	1
	31	59015	(001700–)	Pump, Fuel	1

Fig. 36 – Radiator Hose Group

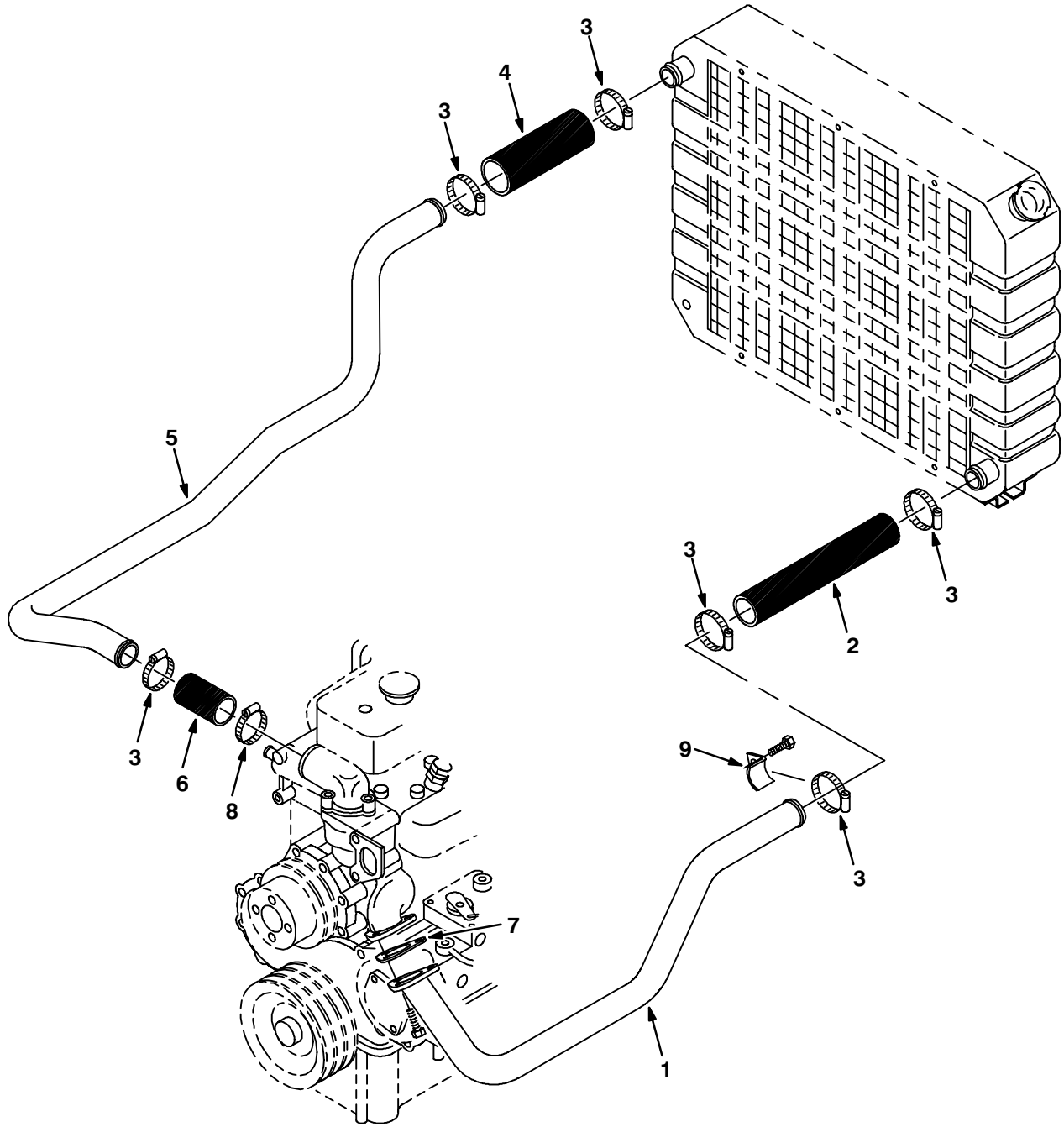

Fig. 36 – Radiator Hose Group

Ref.	Tennant Part No.	Machine Serial Number	Description	Qty.
1	70507	(000000–)	Tube, Radiator, Die	1
2	70635	(000000–)	Hose, Radiator, Lower	1
3	11531	(000000–)	Clamp–Wormdrive, 1.06– 2.00D	6
4	73897	(000000–)	Hose, Rad, Upper	1
5	70753	(000000–)	Tube, Radiator, Upper, Die	1
6	62377	(000000–)	Hose Radiator, 1.50 ldx 3.0 Lg	1
7	73868	(000000–)	Gasket–Water Pk	1
8	22297	(000000–)	Clamp–Wormdrive, 1.56– 2.50D	1
9	74043	(000000–)	Bracket, Tube	1

Fig. 37 – Radiator Group

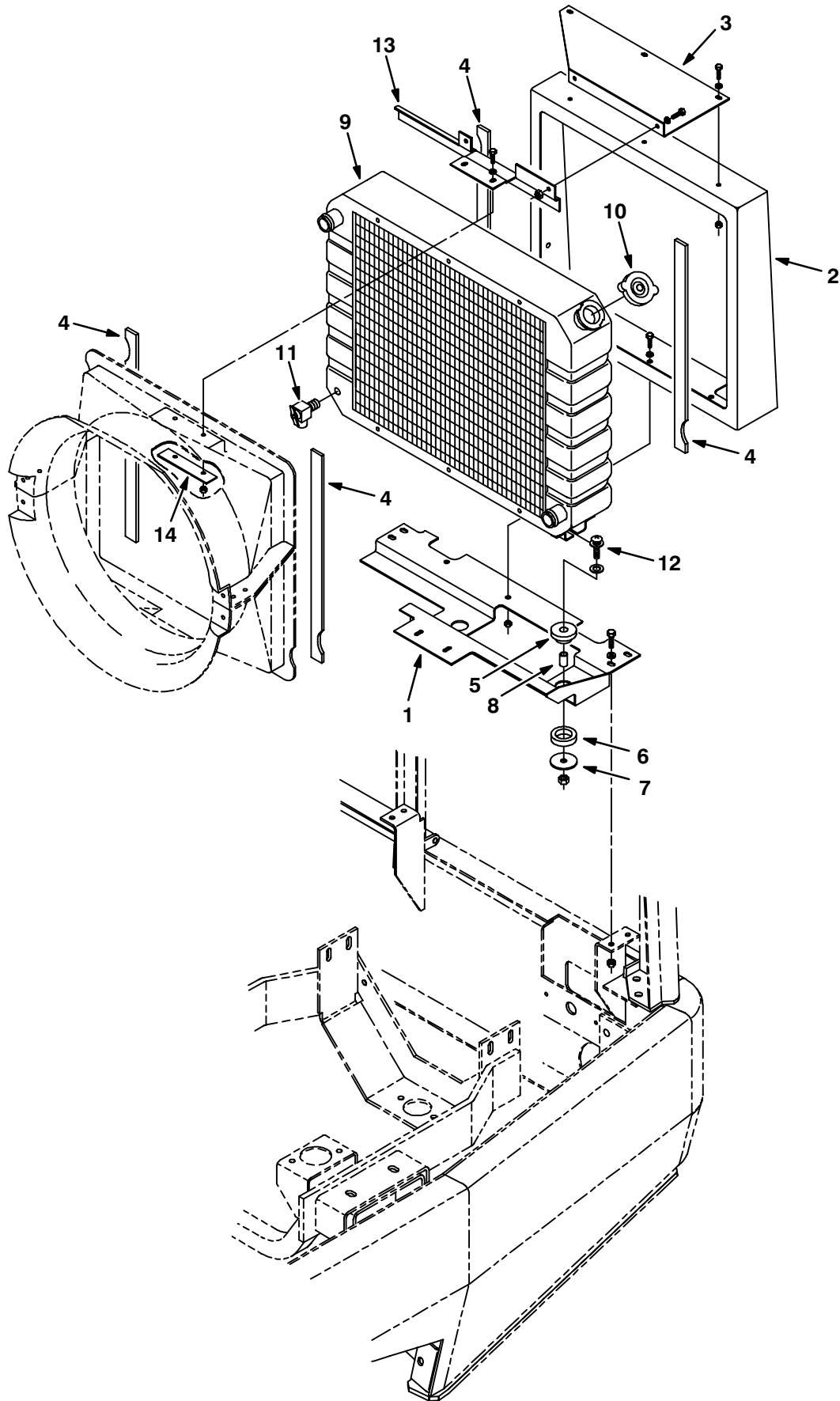

Fig. 37 – Radiator Group

Ref.	Tennant Part No.	Machine Serial Number	Description	Qty.
1	70744	(000000-001223)	Channel Wldt	1
2	64406	(000000-001223)	Duct, Rear	1
3	70710	(000000-001223)	Angle, Top	1
4	63818	(000000-001223)	Seal, Duct	4
5	64621	(000000-001223)	Bushing, Isolator	2
6	64618	(000000-001223)	Ring, Isolator, Outer, Rbr	2
7	58228	(000000-001223)	Plate, Spring – Side Brush	2
8	64299	(000000-001223)	Spacer	2
∇ 9	63191	(000000-001223)	Radiator	1
10	31755	(000000-001223)	Cap, Radiator 7 Psi	1
11	51305	(000000-001223)	Drain Cock,.25Npt Wh#120 Angl	1
12	19577	(000000-001223)	Bolt Carr.38-16X2.00	2
13	70711	(000000-001223)	Angle, Stiffener	1
14	70712	(000000-001223)	Plate, Backing	1

Fig. 38 – Radiator Group

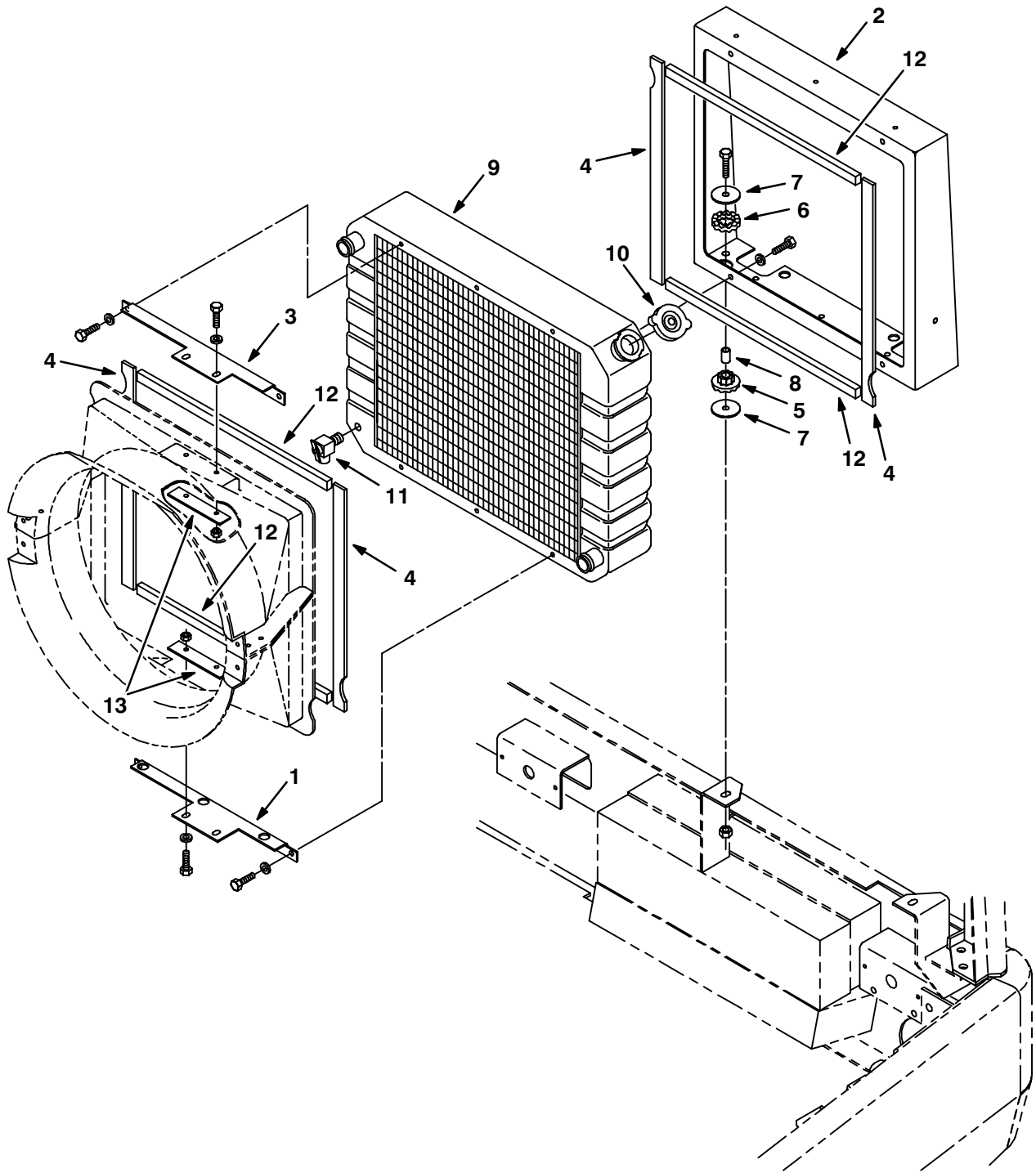

Fig. 38 – Radiator Group

Ref.	Tennant Part No.	Machine Serial Number	Description	Qty.
1	77529	(001224–)	Bracket, Mtg, Shroud, Lower	1
2	77447	(001224–)	Duct, Rear	1
3	77528	(001224–)	Bracket, Mtg, Shroud, Upper	1
4	63818	(001224–)	Seal, Duct	4
5	64621	(001224–)	Bushing, Isolator	2
6	64618	(001224–)	Ring, Isolator, Outer Rbr	2
7	58228	(001224–)	Plate, Spring – Side Brush	4
8	77452	(001224–)	Spacer	2
X 9	73140	(001224–)	Radiator, 4 Row, 6 Fin	1
10	31755	(001224–)	Cap Radiator	1
11	51305	(001224–)	Drain Cock,.25Npt Wh#120 Angl	1
12	59734	(001224–)	Seal, Fan, Vac Outlet	4
13	70712	(001224–)	Plate, Backing	2

Fig. 39 – Cooling Fan and Housing Group

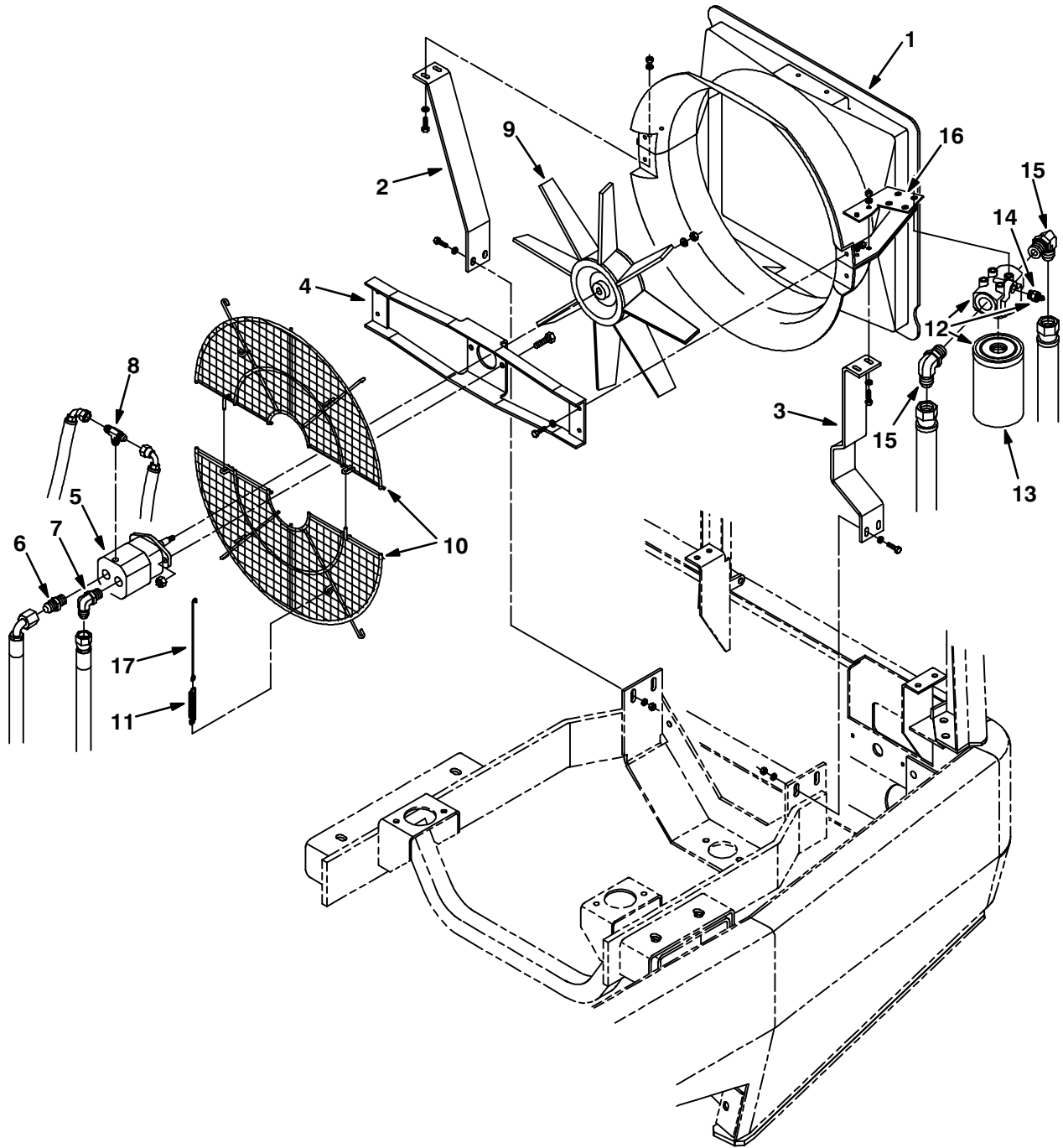

Fig. 39 – Cooling Fan and Housing Group

Ref.	Tennant Part No.	Machine Serial Number	Description	Qty.
1	63279	(000000-001229)	Panel Wldt, Transition, Fan	1
2	63599	(000000-001223)	Angle, Mtg, Shroud, Rh	1
3	70858	(000000-001223)	Angle, Mtg, Shroud, Lh	1
4	70703	(000000-001229)	Channel Wldt, Fan Motor	1
5	63542	(000000-001229)	Motor-Hyd Gear In (See Breakdowns)	1
6	52402	(000000-001229)	Ftg-Hyd Str Jm06/Om08	1
7	47512	(000000-001229)	Ftg-Hyd E90 Jm06/Om08	1
8	31599	(000000-001229)	Ftg-Hyd Tee Jm04Omjm	1
9	63280	(000000-001229)	Fan, Radiator	1
10	70461	(000000-001229)	Screen, Guard	2
11	57792	(000000-001229)	Spring, Tension	2
∇ 12	65220	(000000-001229)	Filter Assy, Spin-On 10Micron	1
13	65221	(000000-001229)	Filter Element Dn	1
14	65222	(000000-001229)	Filter Sender Dn	1
15	46481	(000000-001229)	Ftg-Hyd E90 Jm12/Om12	2
16	70859	(000000-001223)	Bracket, Mtg, Filter	1
17	74042	(000000-001229)	Hook	2

Fig. 40 – Cooling Fan and Housing Group

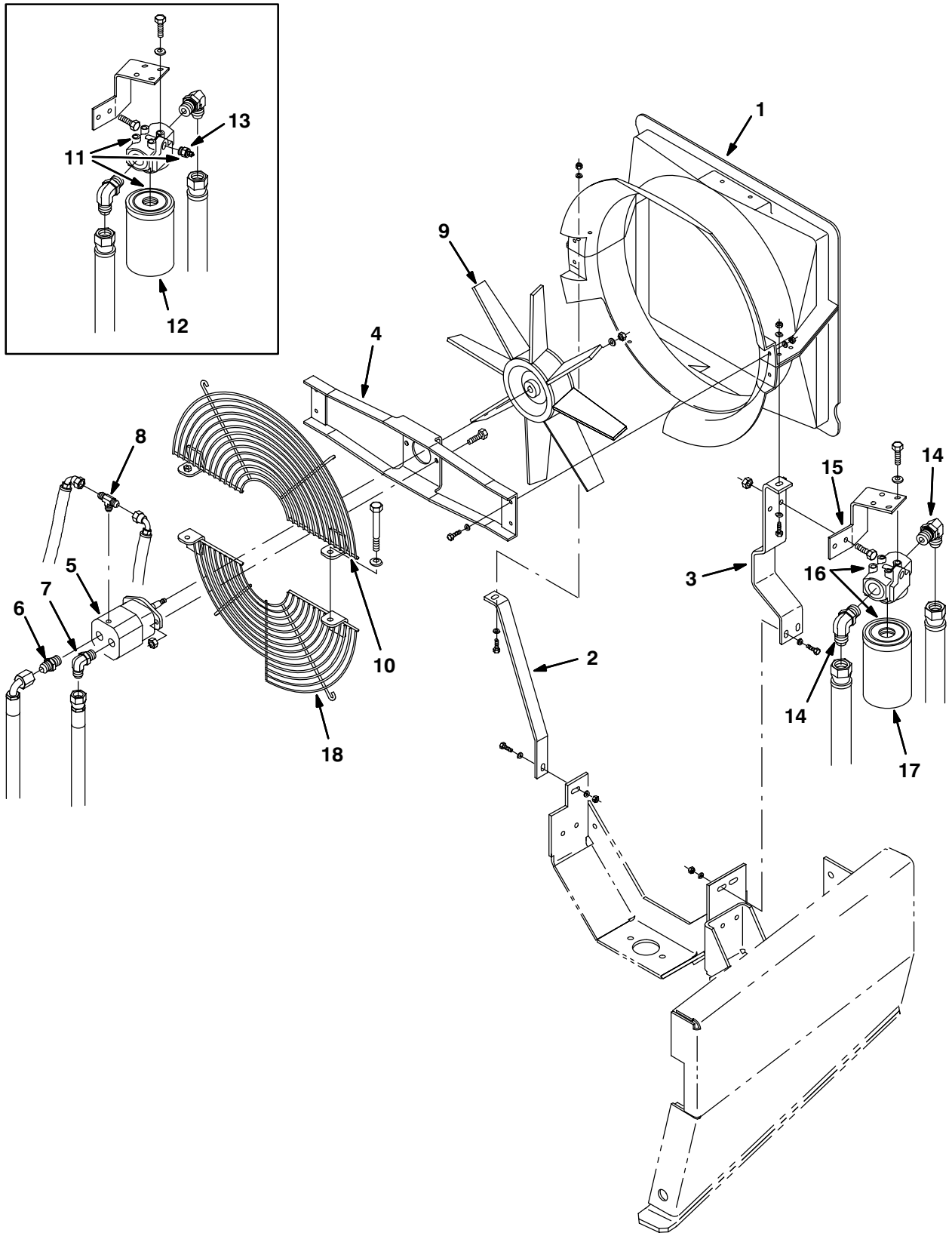

Fig. 40 – Cooling Fan and Housing Group

Ref.	Tennant Part No.	Machine Serial Number	Description	Qty.
1	63279	(001230–) Panel, Transition, Fan	1
2	21689	(001224–) Bracket, Mtg, Shroud, Rh	1
3	77527	(001224–) Bracket, Mtg, Shroud, Lh	1
4	70703	(001230–) Channel Wldt, Fan Motor	1
5	63542	(001230–) Motor–Hyd, Gear In 10.0 (See Breakdowns)	1
6	52402	(001230–) Ftg–Hyd Str Jm06/Om08	1
7	47512	(001230–) Ftg–Hyd E90 Jm06/Om08	1
8	31599	(001230–) Ftg–Hyd Tee Jm04Omjm	1
9	63280	(001230–) Fan, Radiator	1
10	77788	(001230–) Screen, Guard	1
∇ 11	10665	(001230–001405) Filter Assy, Replmt Kit F/65220	1
12	65221	(001230–001405) Element, Filter	1
13	65222	(001230–001405) Sender, Filter, Hydraulic	1
14	46481	(001230–) Ftg–Hyd E90 Jm12/Om12	2
15	77530	(001224–) Bracket, Mounting Filter	1
∇ 16	10664	(001406–) Filter Assy, Spin–On	1
17	65221	(001406–) Element, Filter	1
18	21695	(001230–) Screen, Guard, Lower	1

Fig. 41 – Battery Group

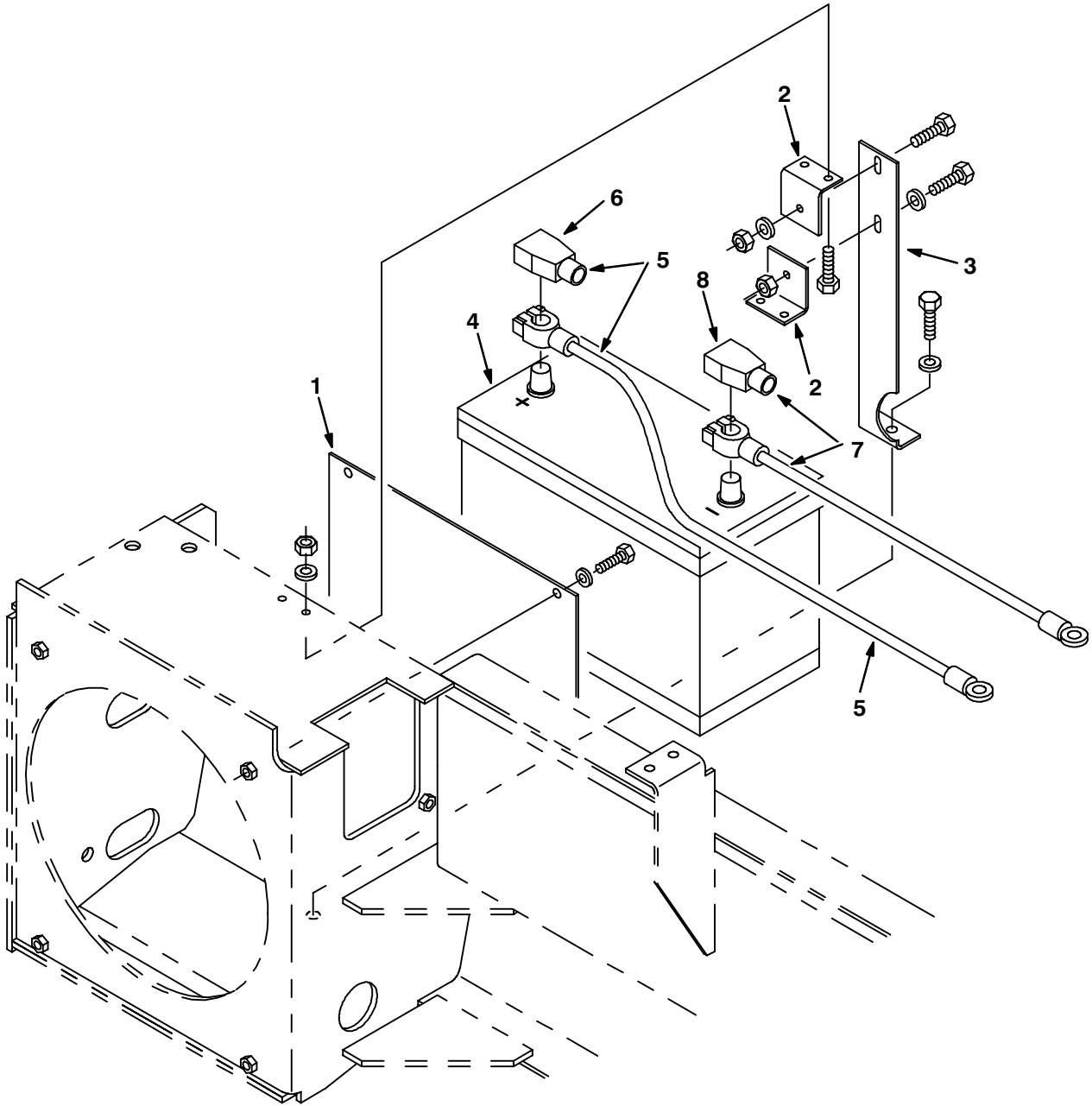

Fig. 41 – Battery Group

Ref.	Tennant Part No.	Machine Serial Number	Description	Qty.
1	70540	(000000-001211)	Plate	1
2	70539	(000000-001211)	Bracket	2
3	70541	(000000-001211)	Bracket	1
4	10136	(000000-001211)	Battery, 12V, Cc Amps:730 Wet	1
∇ 5	60292	(000000-001211)	Wire Assy, 66.0 Lg, 2 Ga, Pos	1
6	68873	(000000-001211)	Boot,Batt.Term. 1-2Ga. Red	1
∇ 7	60293	(000000-001211)	Wire Assy, 42.0 Lg, 2 Ga, Neg	1
8	68872	(000000-001211)	Boot,Batt.Term.1-2Ga. Black	1

Fig. 42 – Battery Group

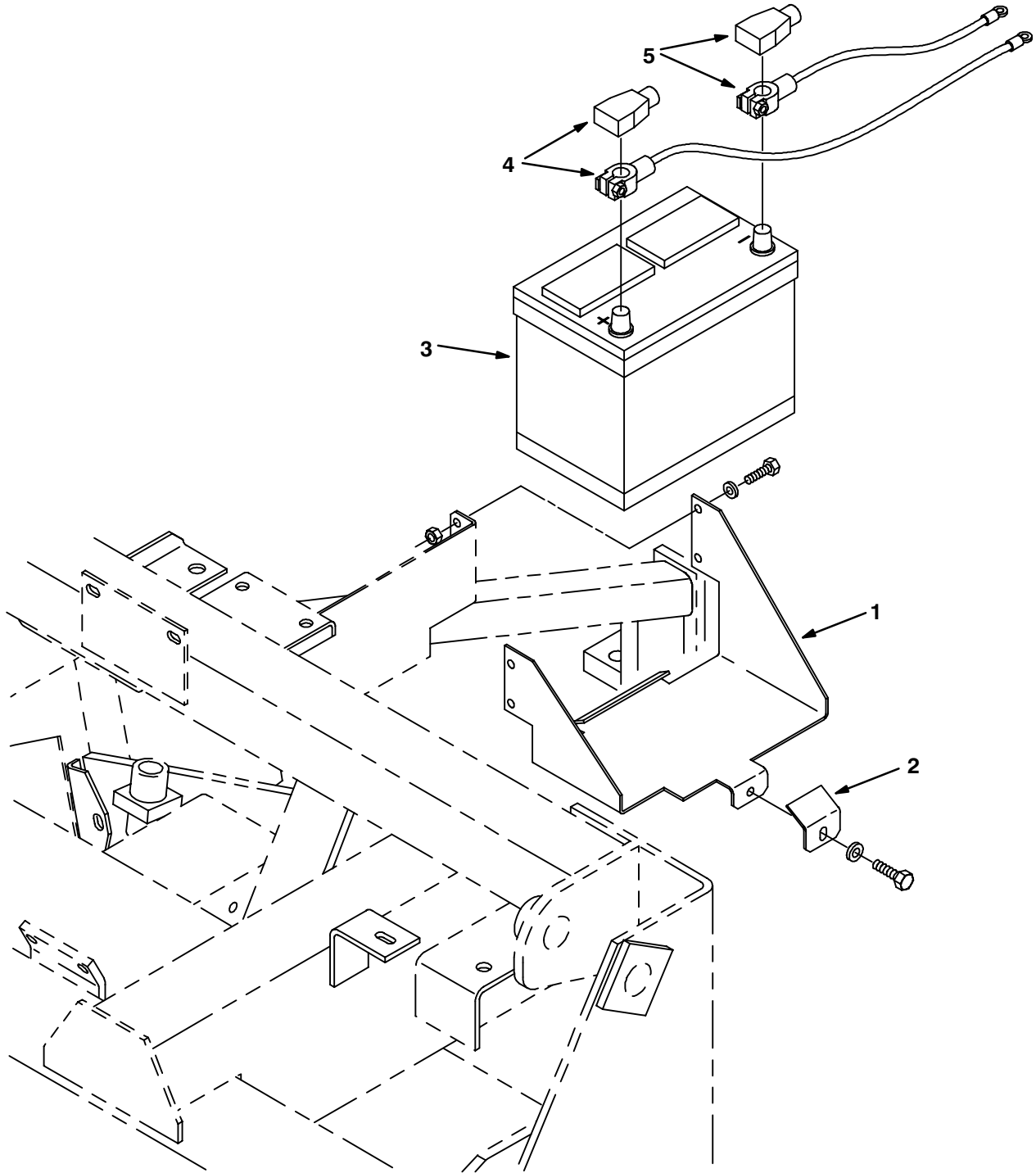

Fig. 42 – Battery Group

Ref.	Tenant Part No.	Machine Serial Number	Description	Qty.
1	77490	(001212–)	Bracket, Mtg, Battery	1
2	77579	(001212–)	Bracket, Battery	1
3	77602	(001212–)	Battery, 12V, Wet	1
4	68869	(001212–)	Cable Assy–Batt,Pos, 48.0, 2Ga	1
5	60293	(001212–)	Wire, 42.0 Lg, 2Ga, Neg	1

Fig. 43 – Rear Wheel Drive Group

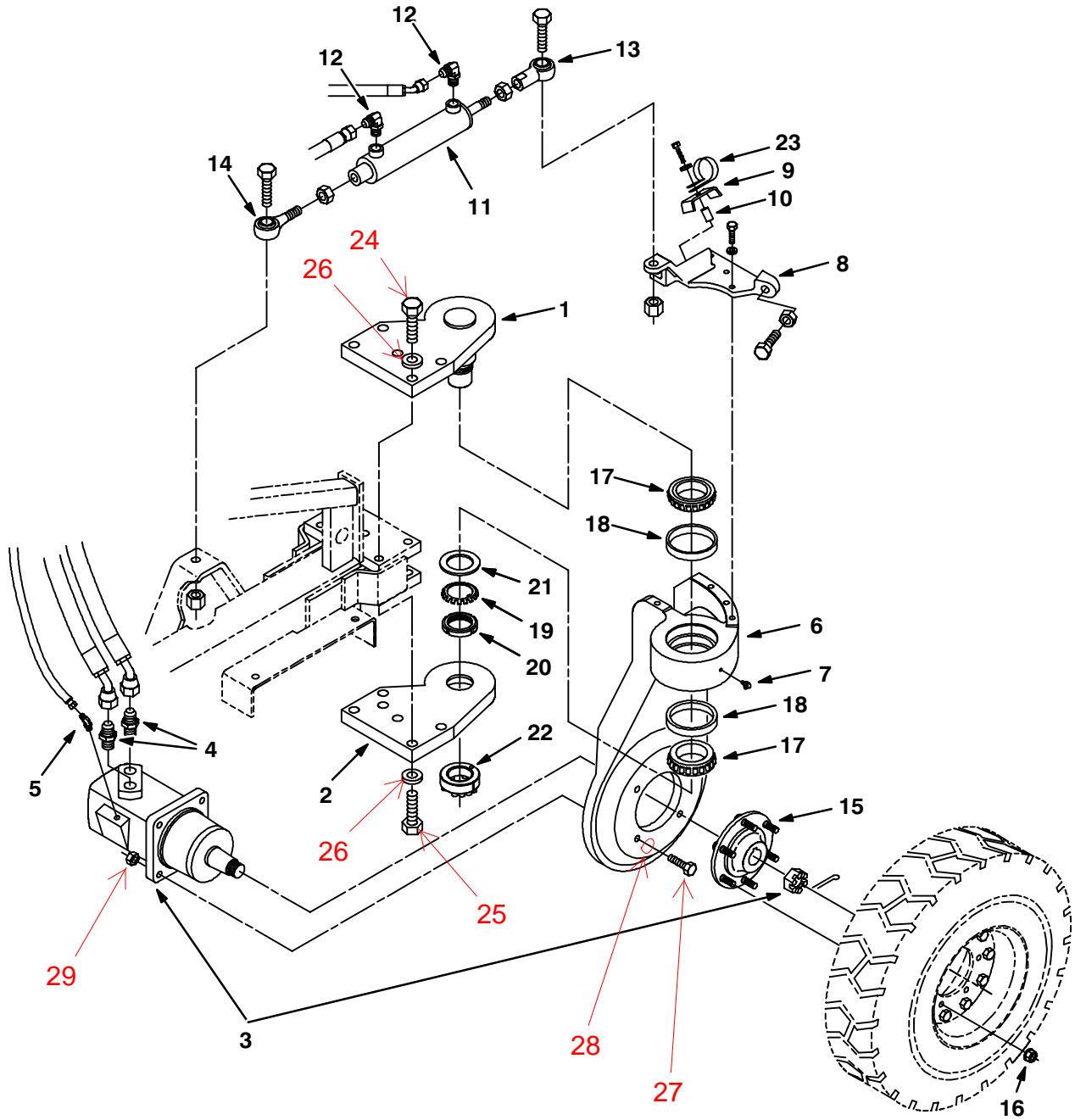

Fig. 43 – Rear Wheel Drive Group

Ref.	Tennant Part No.	Machine Serial Number	Description	Qty.
1	63491	(000000–) Pivot Wldt, Wheel	1
2	63471	(000000–) Plate, Pivot, Wheel	1
3	63426	(000000–) Motor–Hyd Gear In (See Breakdowns)	1
4	67310	(000000–) Ftg–Hyd Str Jm12/Om16	2
5	34359	(000000–) Ftg–Hyd E45 Jm04/Om04	1
6	63540	(000000–) Housing, Sppt, Wheel	1
7	09718	(000000–) Ftg, Grease.25–28Th 90 .75L	1
8	63543	(000000–) Bracket, Steering, Machining	1
9	73733	(000000–) Channel, Retainer	1
10	73731	(000000–) Sleeve, .375B .62D1.06 Stl	1
11	53601	(000000–) Cylinder, Hyd (See Breakdowns)	1
12	56820	(000000–) Ftg–Hyd E90 Jm06/Om06	2
13	64887	(000000–) Balljoint, Rod End	1
14	64886	(000000–) Balljoint, Rod End	1
15	63591	(000000–001258) Housing Assy, Rear Hub	1
15	79140	(001259–) Hub and Stud Assy.	1
16	78999	(000000–001258) Nut, Wheel Lug	6
16	79153	(001259–) Nut, Wheel Lug	6
17	51341	(000000–) Bearing–Cone, 2.63Bore 0.87Wth	2
18	51340	(000000–) Bearing–Cup , 4.33Dia 0.74Wth	2
19	41074	(000000–) Washer,Lock Special	1
20	41073	(000000–) Nut,Lock–Special 2.16–18Uns	1
21	79514	(000000–) Washer	1
22	63496	(000000–) Ring, Retainer, Lock	1
23	67767	(000000–) Clamp, Cable	1
24	06995		Scr, Hex M20 x 2.5 x 70	3
25	06993		Scr, Hex M20 x 2.5 x 60	7
26	39350		Washer, Flt	10
27	39305		Bolt	4
28	32486		Washer	4
29	32985		Nut	4

Fig. 44 – Front Wheels and Brakes Group

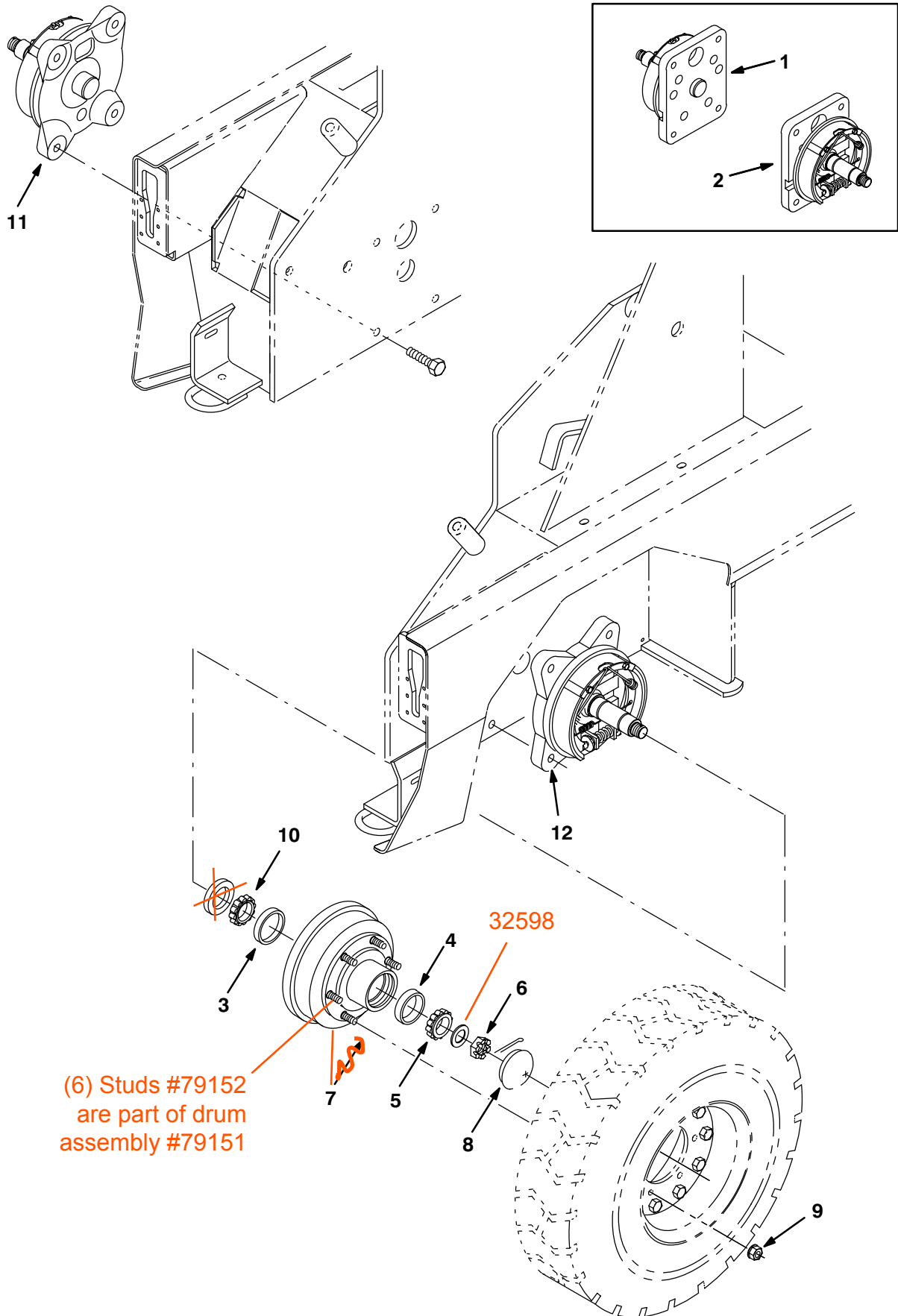

Fig. 44 – Front Wheels and Brakes Group

Ref.	Tennant Part No.	Machine Serial Number	Description	Qty.
1	63290	(000000-001354)	Brake, Hyd, Rh (Repl. by 77790)	1
2	63286	(000000-001354)	Brake, Hyd, Lh (Repl. by 77770)	1
3	17808	(000000-)	Bearing-Cup, 2.72Dia 0.59Wth	2
4	51338	(000000-)	Bearing-Cup, 2.56Dia 0.55Wth	2
5	51193	(000000-)	Bearing-Cone, 1.38Bore 0.72Wth	2
6	14242	(000000-)	Nut-Hxslot 1.00-20 Pltd	2
7	63281	(000000-001258)	Drum, Brake	2
7	79151	(001259-)	Drum Assy, Brake 9/16	2
8	51373	(000000-)	Cap, Grease Black Paint	2
9	78999	(000000-001258)	Nut-Wheel .50-20	12
9	79153	(001259-)	Nut, Wheel Lug, 9/16-18	12
10	17809	(000000-)	Bearing-Cone, 1.50Bore 0.75Wth	2
11	77790	(001355-)	Brake Assy, Rh	1
12	77770	(001355-)	Brake Assy, Lh	1

Fig. 45 – Wheel Assembly

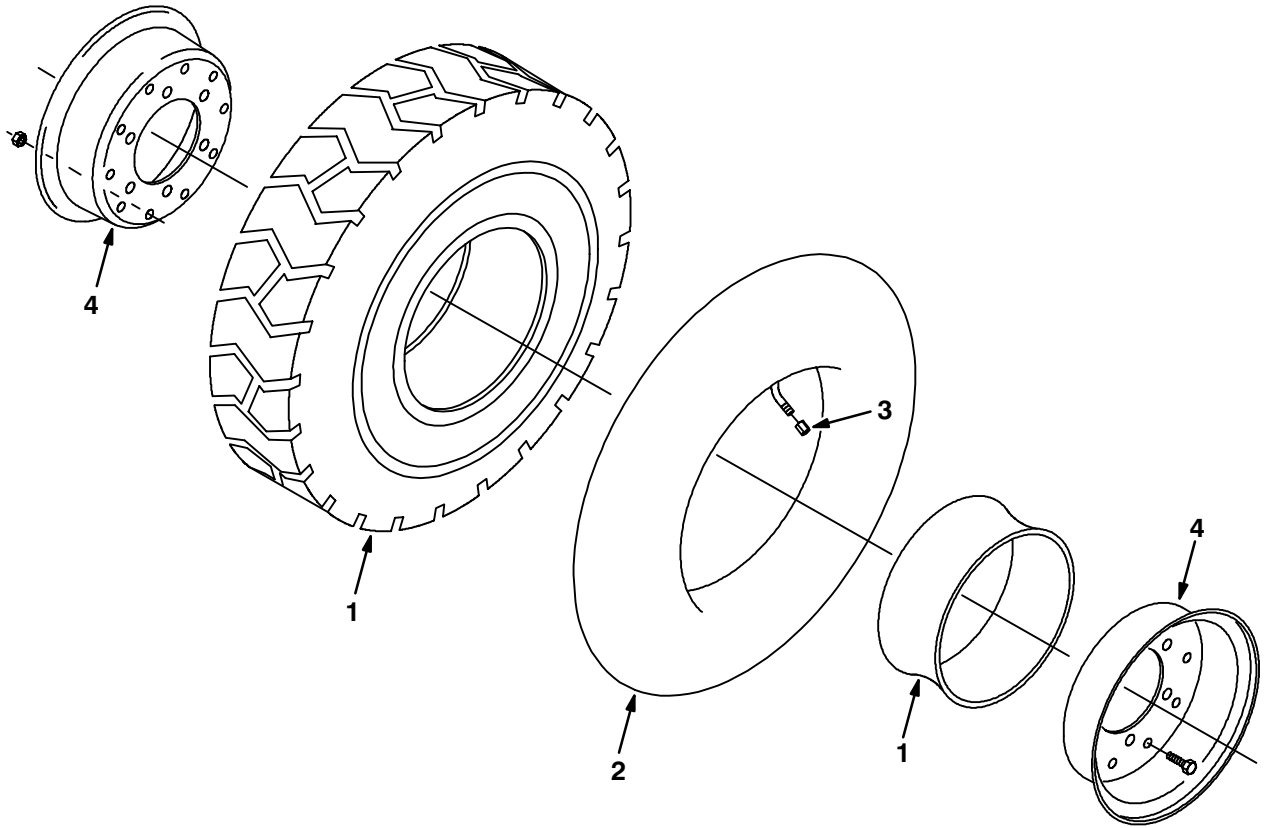

Fig. 45 – Wheel Assembly

Ref.	Tennant Part No.	Machine Serial Number	Description	Qty.
∇	63850	(000000–) Tire & Rim Assy, Pneu 6.50–10	3
1	64059	(000000–) Tire & Flap Assy	1
2	64058	(000000–) Tube, Inner	1
3	45786	(000000–) Cap, Valve Stem	1
4	63218	(000000–) Hub Assy	1

Fig. 46 – Brake Pedals Group

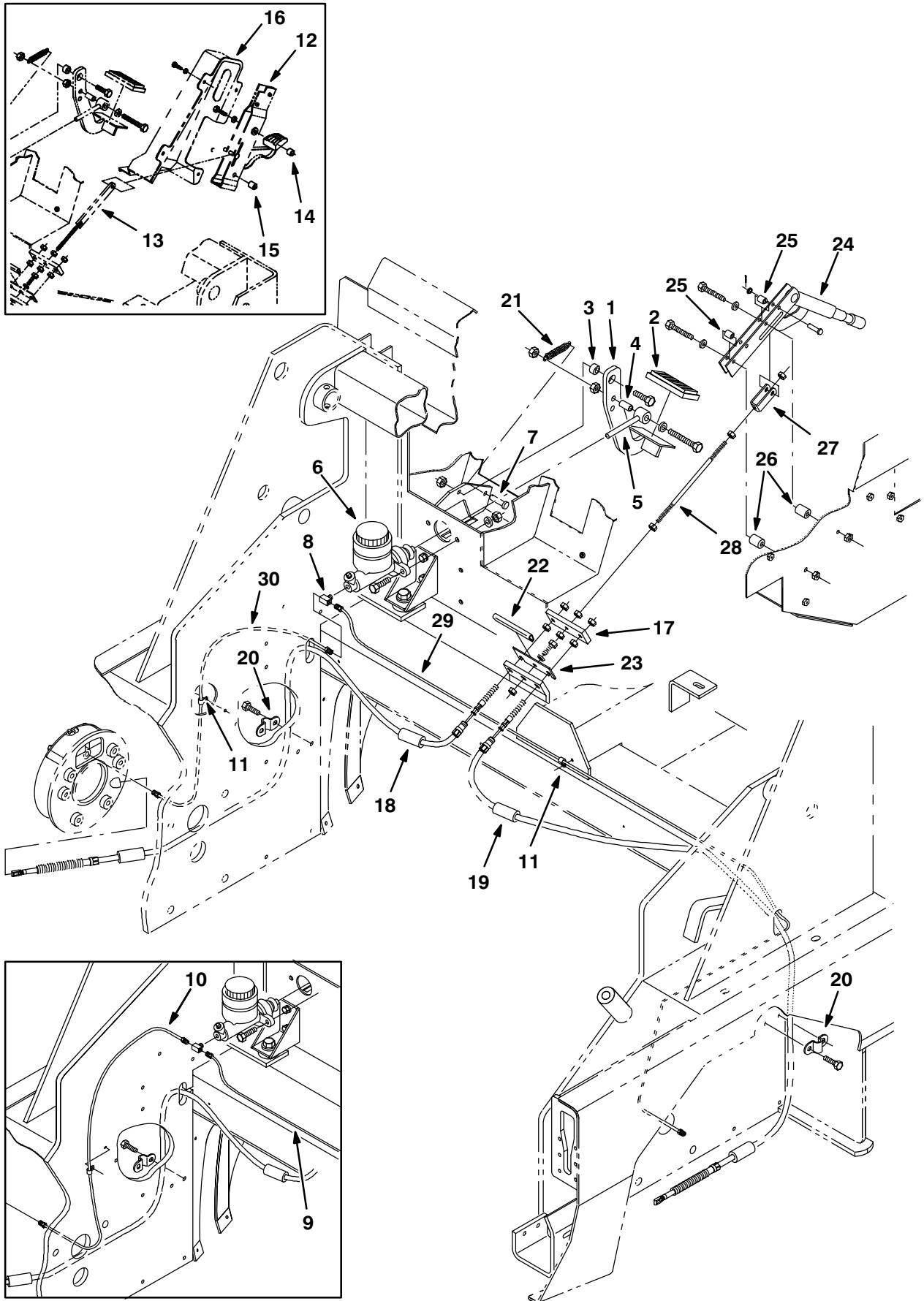

Fig. 46 – Brake Pedals Group

Ref.	Tennant Part No.	Machine Serial Number	Description	Qty.
1	63295	(000000–)	Pedal Wldt	1
2	51109	(000000–)	Pad	1
3	64635	(000000–)	Spacer	1
4	57311	(000000–)	Spacer–.50 Od X .055W X 1.0	1
5	70550	(000000–)	Rod Wldt, Push, Brake	1
6	64950	(000000–)	Cylinder, Master Brake	1
7	76653	(000000–)	Pin, Clevis .375D X 1.000 Lg	1
8	51483	(000000–)	Ftg,Brass,Tee 06lf– 02Pm– 06lf	1
9	64554	(000000–001354)	Tube Assy, Brake,Metric 80.0Lg	1
10	64550	(000000–001354)	Tube Assy, Brake,Metric 34.0Lg	1
11	46236	(000000–)	Clamp–Cable, 0.25Dia 0.56Wth	5
12	77646	(000000–001102)	Brake, Hand, Replmt Kit	1
13	70511	(000000–001102)	Rod Wldt, Adjustment	1
14	70505	(000000–001102)	Sleeve, .380B .62D .50 Smls	1
15	70504	(000000–001102)	Sleeve, .380B .62D .66 Smls	1
16	76639	(000000–001102)	Cover, Brake Kit	1
17	70506	(000000–)	Bar, Equalizer	1
18	64556	(000000–)	Cable, Brake, Park	1
19	64558	(000000–)	Cable, Brake, Park	1
20	65129	(000000–)	Clamp, Cable– Brake	2
21	75575	(000000–)	Spring, Tens,0.5Dx.06Wire 2.5L	1
22	31775	(000000–)	Molding, Trim 11–14Ga 4.0	1
23	74022	(000000–)	Strip, Retainer, Brake Cable	1
24	51545	(001103–)	Lever, Brake	1
25	51562	(001103–)	Sleeve, .344B .50D .81 Cr.Anc	2
26	86034	(001103–)	Spacer, Brake	2
27	76491	(001103–)	Bracket, Adjuster, Brake	1
28	76490	(001103–)	Rod–Thread, 2End M08X1.25X10Lg	1
29	79593	(001355–)	Tube Assy, Brake	1
30	79594	(001355–)	Tube Assy, Brake	1

Fig. 47 – Directional Pedal Group

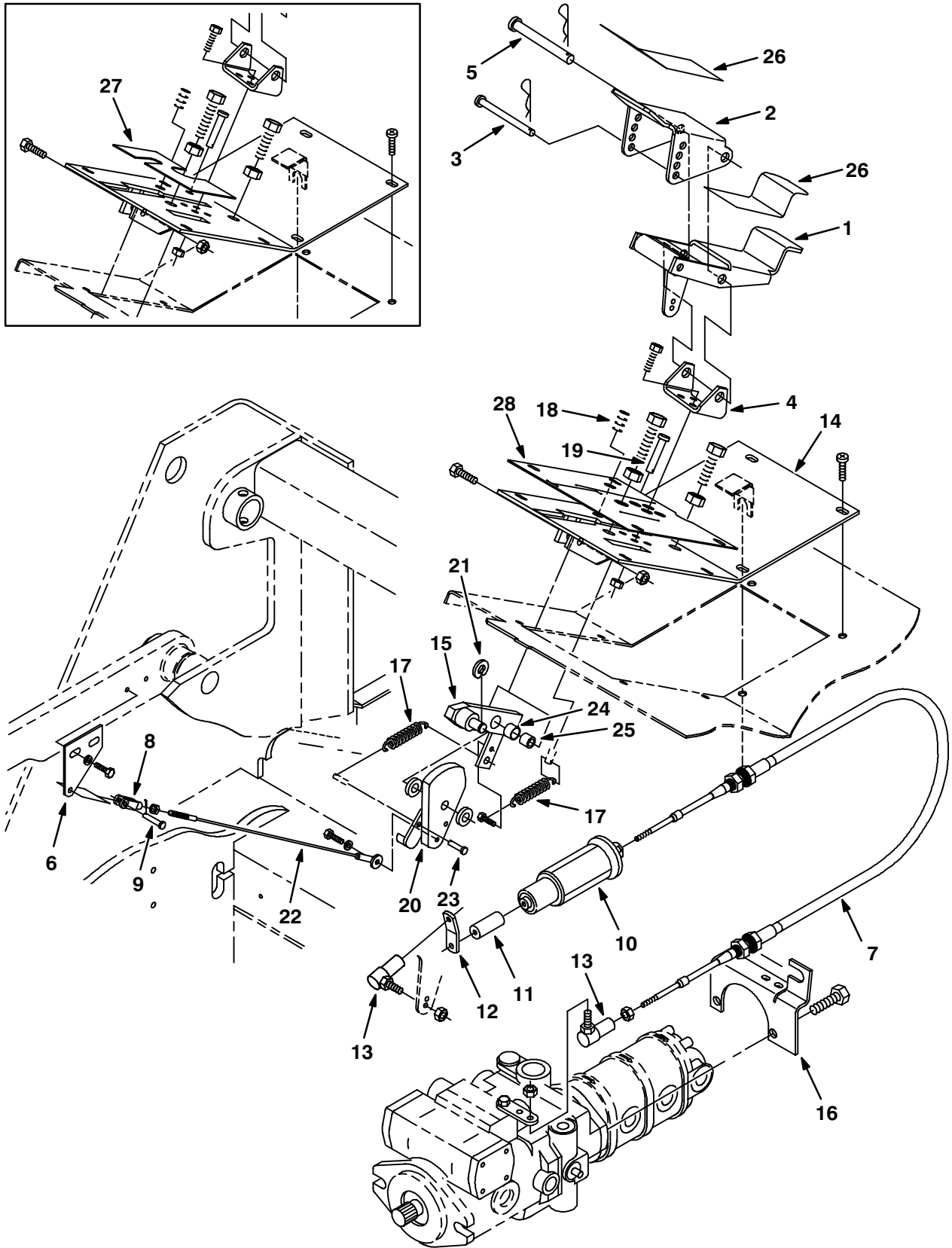

Fig. 47 – Directional Pedal Group

Ref.	Tennant Part No.	Machine Serial Number	Description	Qty.
1	74052	(000000–)	Pedal Wldt, Lower	1
2	75305	(000000–)	Pedal, Upper	1
3	59672	(000000–)	Pin, Clevis .31 Dia X 4.50 Lg	1
4	63275	(000000–)	Bracket, Mounting Dir Cont	1
5	59668	(000000–)	Pin, Clevis .50 Dia X 4.50 Lg	1
6	70725	(000000–)	Plate	1
7	63276	(000000–)	Cable, Push,Pull	1
8	14595–1	(000000–)	Clevis,Adjust.0.25–28Th.Cad.	1
9	14605	(000000–)	Pin,Clevis,0.25 Dia.X 0.75 Lg	1
10	63292	(000000–)	Spring, Propel, Centering	1
11	65246	(000000–)	Spacer	1
12	64632	(000000–)	Bracket, Adjusting, Spring	1
13	14601	(000000–)	Ball Joint, 250–28	2
14	63551	(000000–)	Panel, Access	1
15	70747	(000000–)	Bar Wldt, Pivot	1
16	76427	(000000–)	Bracket, Mounting,Alarm Switch	1
17	54222	(000000–)	Sprng, Tens,1.000dx.09Wire2.8 L	2
18	76523	(000000–)	Screw–Set M10 X 1.50 2045H	1
19	76647	(000000–)	Pin, Clevis .375D X 1.312 Lg	1
20	70783	(000000–)	Cam Wldt	1
21	86953	(000000–)	Ring,Retain,Ex,0.50 Stl Steel	2
22	70749	(000000–)	Cable, Speed Control	1
23	82168	(000000–)	Pin, Clevis .25 Dia, 1.000 Lg.	1
24	07449	(000000–)	Bearing, Fiberglide	1
25	74051	(000000–)	Sleeve, .408B .62D .53Stl	1
26	82839	(000000–)	Pad, Tread	1
27	76453	(000000–001241)	Seal, Rubber, Propel Pedal	1
28	79116	(001242–)	Seal, Dust	1

Fig. 48 – Hydraulic Pumps Group

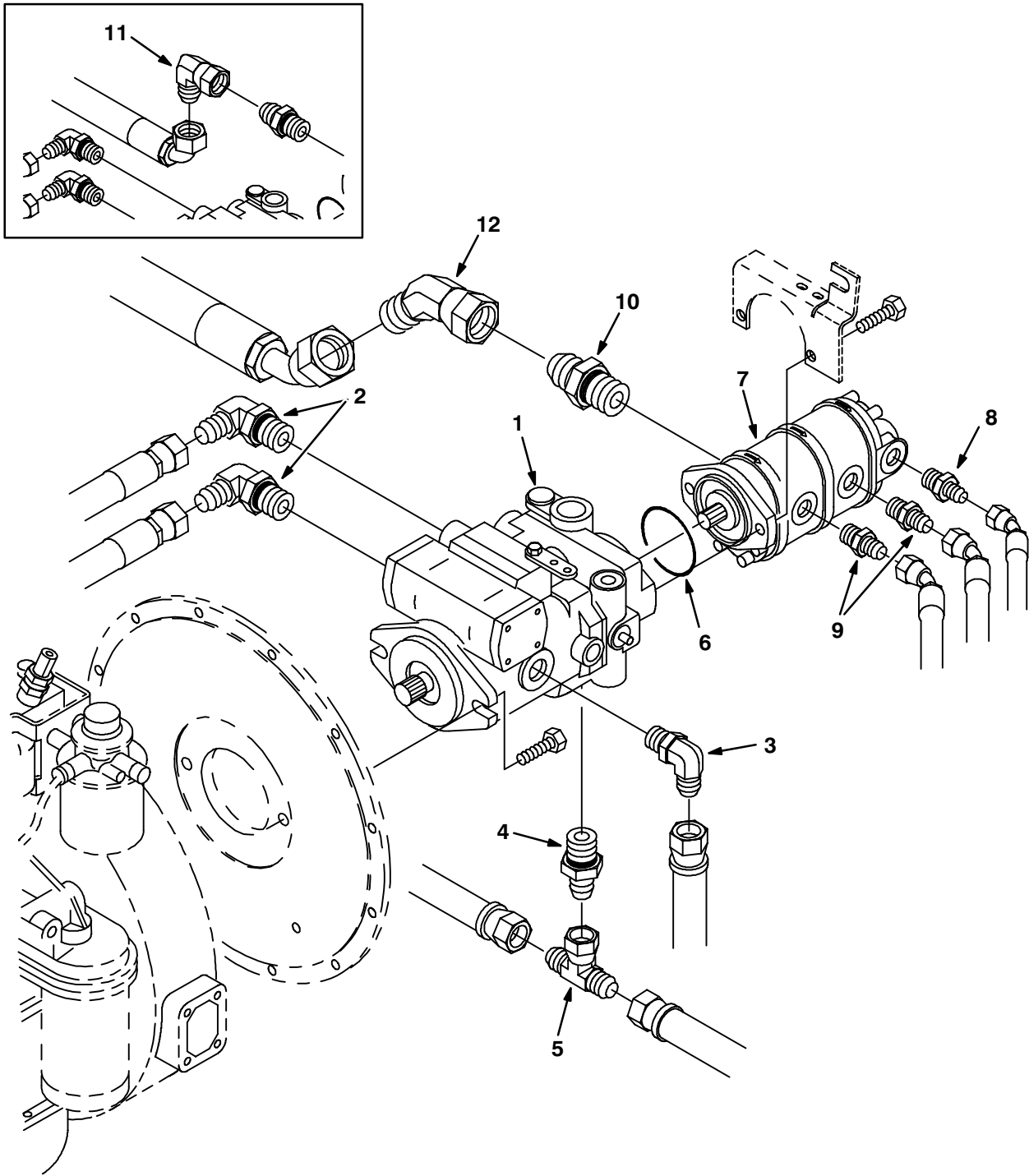
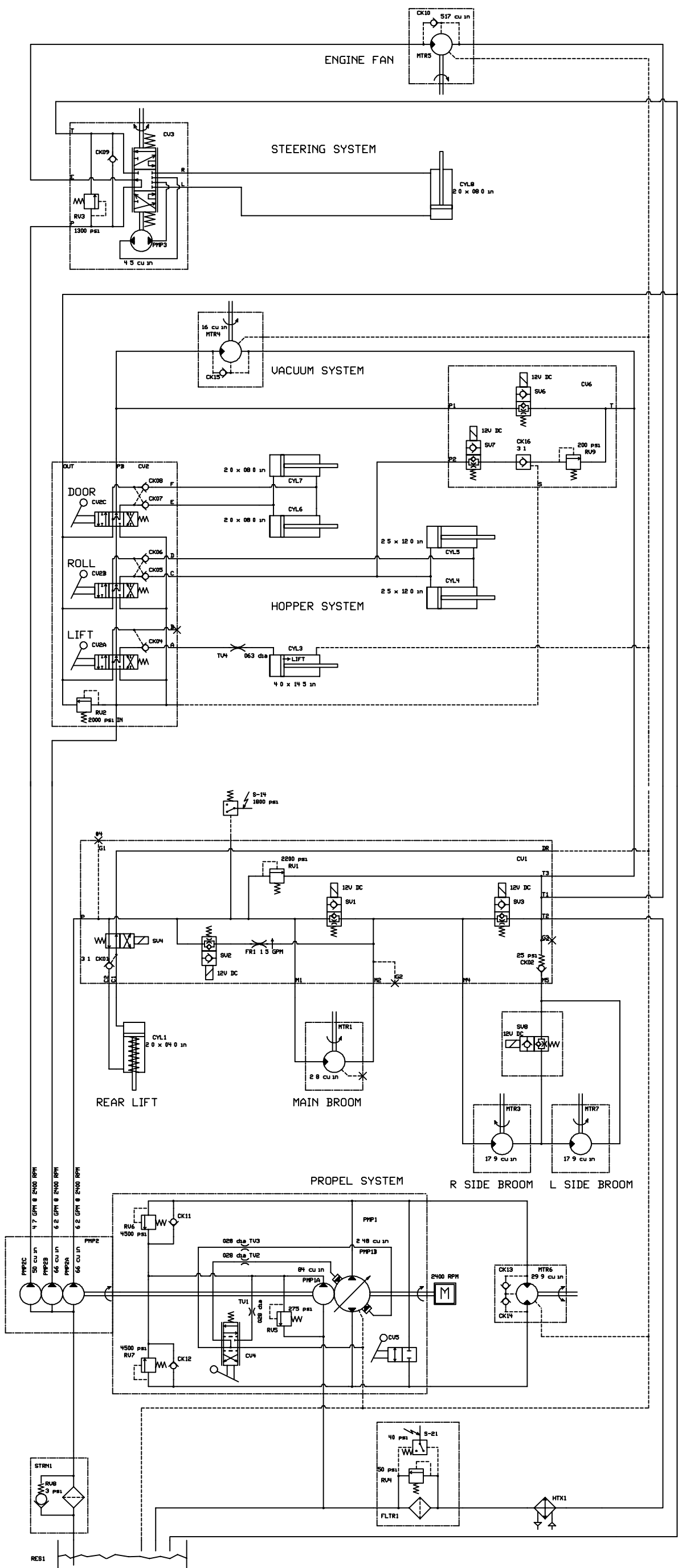

Fig. 48 – Hydraulic Pumps Group

Ref.	Tennant Part No.	Machine Serial Number	Description	Qty.
1	62548	(000000-001164)	Pump-Hyd Piston V (see Breakdowns)	1
1	74163	(001165-) Pump-Hyd Piston V (see Breakdowns)	1
2	52911	(000000-) Ftg-Hyd E90 Jm12/Om16	2
3	46481	(000000-) Ftg-Hyd E90 Jm12/Om12	1
4	67310	(000000-) Ftg-Hyd Str Jm12/Om16	1
5	62389	(000000-) Ftg-Hyd Tee Jm12/Jfjm	1
6	65145-1	(000000-) O-Ring Gland	1
7	62561	(000000-) Pump-Hyd Gear Ex (See Breakdowns)	1
8	47508	(000000-) Ftg-Hyd Str Jm06/Om10	1
9	56692	(000000-) Ftg-Hyd Str Jm08/Om10	2
10	58858	(000000-) Ftg-Hyd Str Jm20/Om20	1
11	19459	(000000-001050)	Ftg-Hyd E90 Jm20/Jf20	1
12	19544	(001051-) Ftg-Hyd E45 Jm20/Jf20	1

Fig. 49 – Hydraulic Schematic
(for machines below serial number xxxxxx)



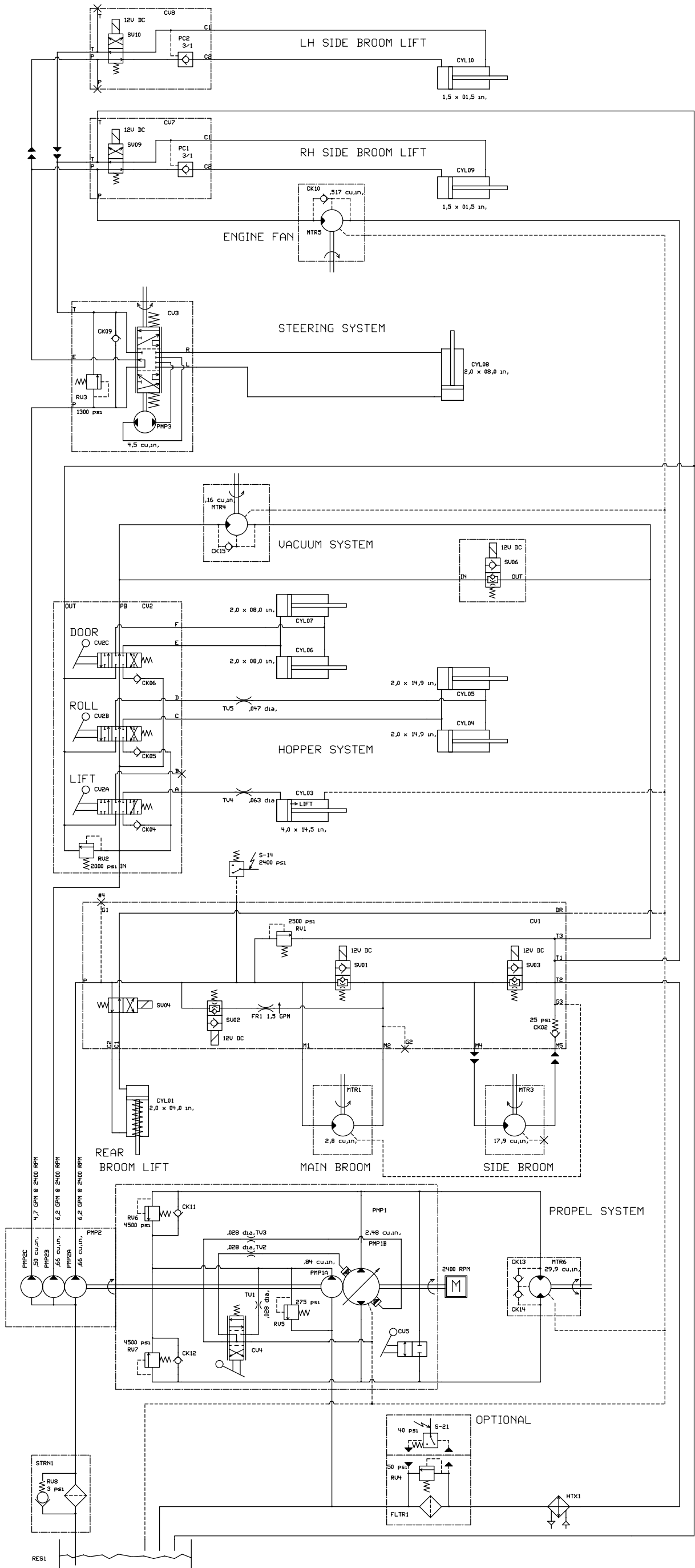

Fig. 50 – Hydraulic Schematic
(for machines serial number xxxxxx and above)

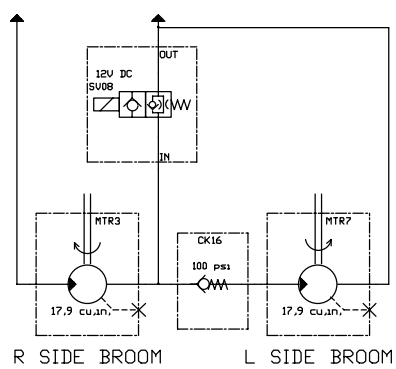

Fig. 51 – Hydraulic Hose Group
(for machines below serial number xxxxxx)

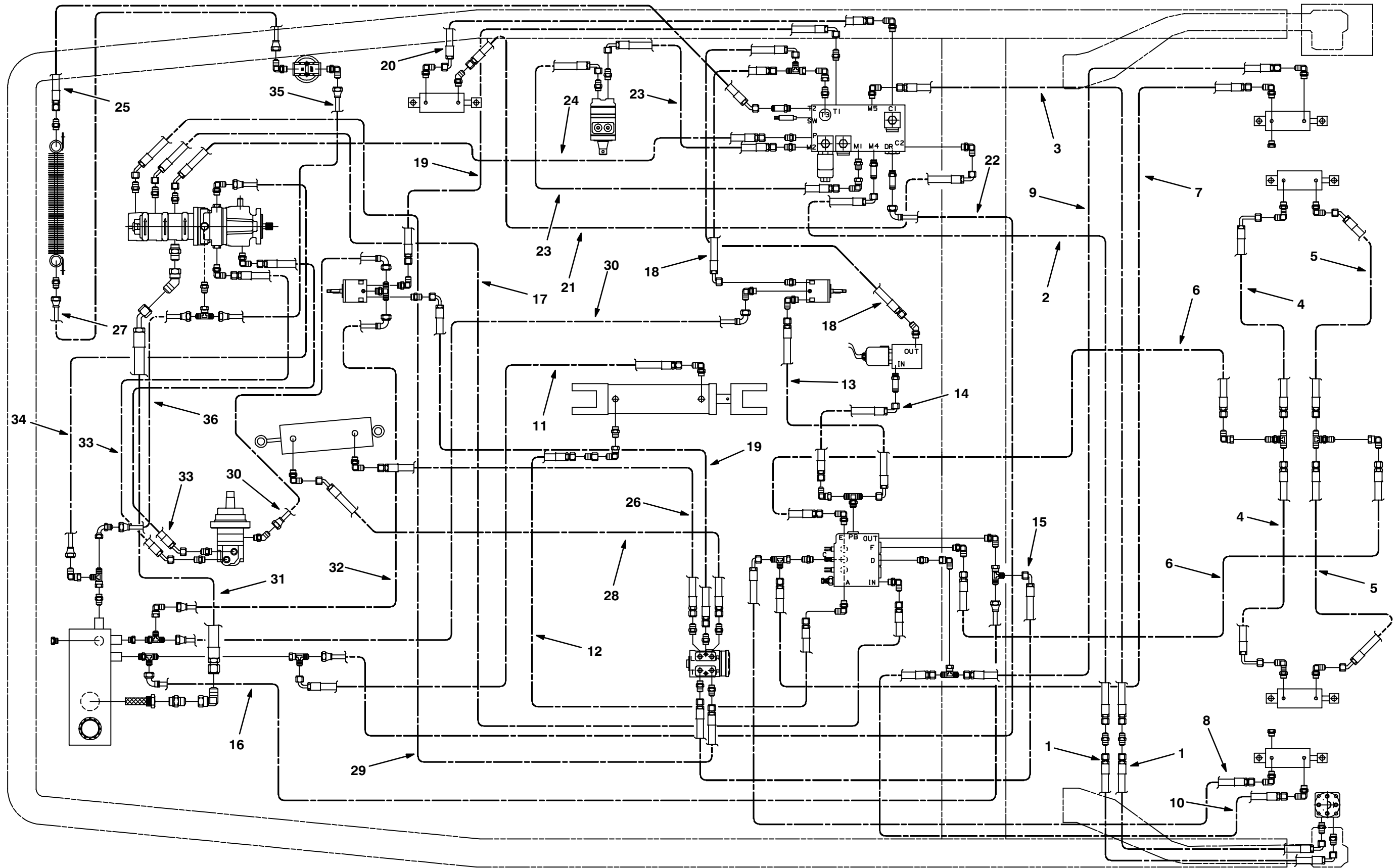

Fig. 51 – Hydraulic Hose Group
(for machines below serial number xxxxxx)

Ref.	Tennant Part No.	Machine Serial Number	Description	Qty.
1	65194	(000000-xxxxxx)	Hose-Hyd Med06 Jf/J9	2
2	65197	(000000-xxxxxx)	Hose-Hyd Med08 Jf/J9	1
3	65224	(000000-xxxxxx)	Hose-Hyd Med08 Jf/Jf	1
4	65188	(000000-xxxxxx)	Hose-Hyd Med04 Jf/J19	2
5	57173	(000000-xxxxxx)	Hose-Hyd Med04 Jf/J4	2
6	76499	(000000-001054)	Hose-Hyd Replm Kit 800/810	2
6	76498	(001055-xxxxxx)	Hose-Hyd Med04 Jf/Jf	2
7	65208	(000000-xxxxxx)	Hose-Hyd Med04 Jf/Jf	1
8	65209	(000000-xxxxxx)	Hose-Hyd Med04 Jf/J9	1
9	65211	(000000-xxxxxx)	Hose-Hyd Med04 Jf/Jf	1
10	65210	(000000-xxxxxx)	Hose-Hyd Med04 Jf/Jf	1
11	71552	(000000-xxxxxx)	Hose-Hyd Med06 Jf/J9	1
12	82814	(000000-xxxxxx)	Hose-Hyd Med04 Jf/Jf	1
13	82843	(000000-xxxxxx)	Hose-Hyd Med08 Jf/J9	1
14	82820	(000000-xxxxxx)	Hose-Hyd Med08 Jf/J9	1
15	65195	(000000-xxxxxx)	Hose-Hyd Med06 Jf/J9	1
16	65212	(000000-xxxxxx)	Hose-Hyd Low06 Jf/J9	1
17	65204	(000000-xxxxxx)	Hose-Hyd Med08 Jf/J4	1
18	34355	(000000-xxxxxx)	Hose-Hyd Med08 Jf/J9	2
19	65194	(000000-xxxxxx)	Hose-Hyd Med06 Jf/J9	2
20	34379	(000000-xxxxxx)	Hose-Hyd Med04 Jf/J9	1
21	57963	(000000-xxxxxx)	Hose-Hyd Med04 Jf/J9	1
22	65213	(000000-xxxxxx)	Hose-Hyd Low06 Jf/J9	1
23	34360	(000000-xxxxxx)	Hose-Hyd Med08 Jf/J9	2
24	33799	(000000-xxxxxx)	Hose-Hyd Med08 Jf/J4	1
25	65199	(000000-xxxxxx)	Hose-Hyd Med12 Jf/J4	1
26	01987	(000000-xxxxxx)	Hose-Hyd Med06 Jf/Jf	1
27	57485	(000000-xxxxxx)	Hose-Hyd Low12 Jf/Jf	1
28	76497	(000000-xxxxxx)	Hose-Hyd Med06 Jf/J4	1
29	65191	(000000-xxxxxx)	Hose-Hyd Med06 Jf/J4	1
30	02549	(000000-xxxxxx)	Hose-Hyd Low04 Jf/J9	2
31	76615	(000000-001050)	Hose-Hyd Replmt Kit 800/810	1
31	19618	(001051-xxxxxx)	Hose-Hyd Suc20 Jf/J4	1
32	65196	(000000-xxxxxx)	Hose-Hyd Low 04 Jf/J9	1
33	65201	(000000-xxxxxx)	Hose-Hyd Med12 Jf/J4	2
34	65205	(000000-xxxxxx)	Hose-Hyd Low12 Jf/Jf	1
35	57483	(000000-xxxxxx)	Hose-Hyd Low12 Jf/Jf	1
36	65202	(000000-xxxxxx)	Hose-Hyd Low12 Jf/Jf	1

Fig. 52 – Hydraulic Hose Group
(for machines serial number xxxxxx and above)

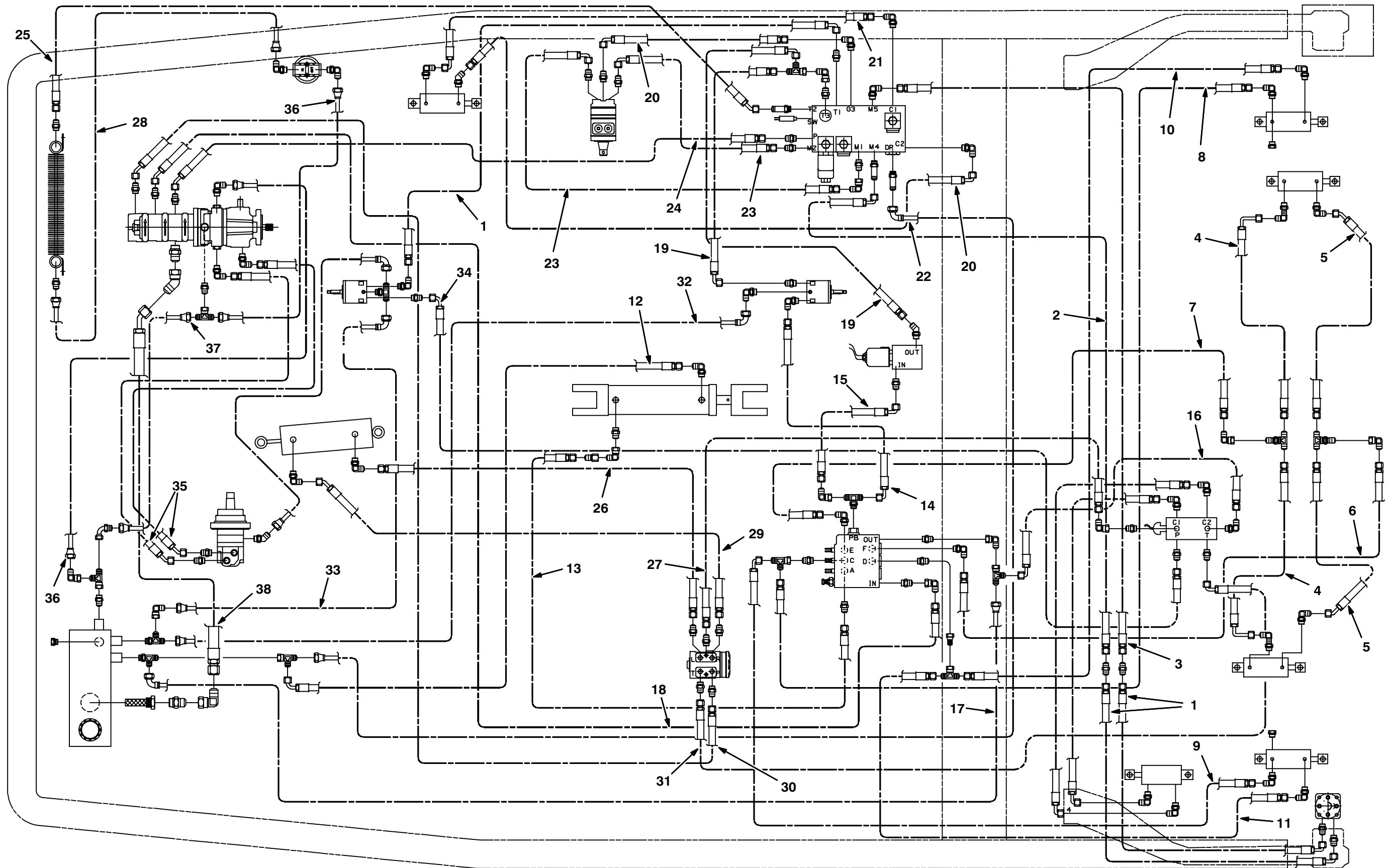

Fig. 52 – Hydraulic Hose Group
(for machines serial number xxxxxx and above)

Ref.	Tennant Part No.	Machine Serial Number	Description	Qty.
1	65194	(xxxxxx-) Hose-Hyd Med06	3
2	65197	(xxxxxx-) Hose-Hyd Med08	1
3	65224	(xxxxxx-) Hose-Hyd Med08	1
4	65188	(xxxxxx-) Hose-Hyd	2
5	57173	(xxxxxx-) Hose-Hyd Med04 Jf/J4	2
6	76498	(xxxxxx-) Hose-Hyd Ar 04	1
7	79642	(xxxxxx-) Hose-Hyd Ar04	1
8	21117	(xxxxxx-) Hose-Hyd Ar 04	1
9	21119	(xxxxxx-) Hose-Hyd Ar 04	1
10	77641	(xxxxxx-) Hose-Hyd Ar 04	1
11	77640	(xxxxxx-) Hose-Hyd Ar 04	1
12	71552	(xxxxxx-) Hose-Hyd	1
13	55700	(xxxxxx-) Hose-Hyd Med04 Jf/Jf	1
14	82843	(xxxxxx-) Hose-Hyd Med08 Jf/J9	1
15	82820	(xxxxxx-) Hose-Hyd Med78 Jf/J9	1
16	65195	(xxxxxx-) Hose-Hyd Med06	1
17	65212	(xxxxxx-) Hose-Hyd Low06	1
18	65204	(xxxxxx-) Hose-Hyd Med08	1
19	34355	(xxxxxx-) Hose-Hyd Med08 Jf/J9	2
20	57963	(xxxxxx-) Hose-Hyd Med04	4
21	34379	(xxxxxx-) Hose-Hyd Med04	1
22	65213	(xxxxxx-) Hose-Hyd Low06	1
23	34360	(xxxxxx-) Hose-Hyd Med08 Jf/J9	2
24	33799	(xxxxxx-) Hose-Hyd Med08 Jf/J4	1
25	65199	(xxxxxx-) Hose-Hyd Med12	1
26	01987	(xxxxxx-) Hose-Hyd Med06 Jf/Jf	1
27	16431	(xxxxxx-) Hose-Hyd Med06 Jf/Jf	1
28	57485	(xxxxxx-) Hose-Hyd Low12 Jf/Jf	1
29	76497	(xxxxxx-) Hose-Hyd Med06	1
30	65191	(xxxxxx-) Hose-Hyd Med06	1
31	57944	(xxxxxx-) Hose-Hyd Med06 Jf/J9	1
32	02549	(xxxxxx-) Hose-Hyd Low04 Jf/J9	2
33	65196	(xxxxxx-) Hose-Hyd Low 04	1
34	31563	(xxxxxx-) Hose-Hyd Med06 Jf/J9	1
35	65201	(xxxxxx-) Hose-Hyd Med12	2
36	65205	(xxxxxx-) Hose-Hyd Low12	2
37	65202	(xxxxxx-) Hose-Hyd Low12	1
38	77473	(xxxxxx-) Hose-Hyd Suc20 Spcl 22.5	1

Fig. 53 – Hydraulic Reservoir Group

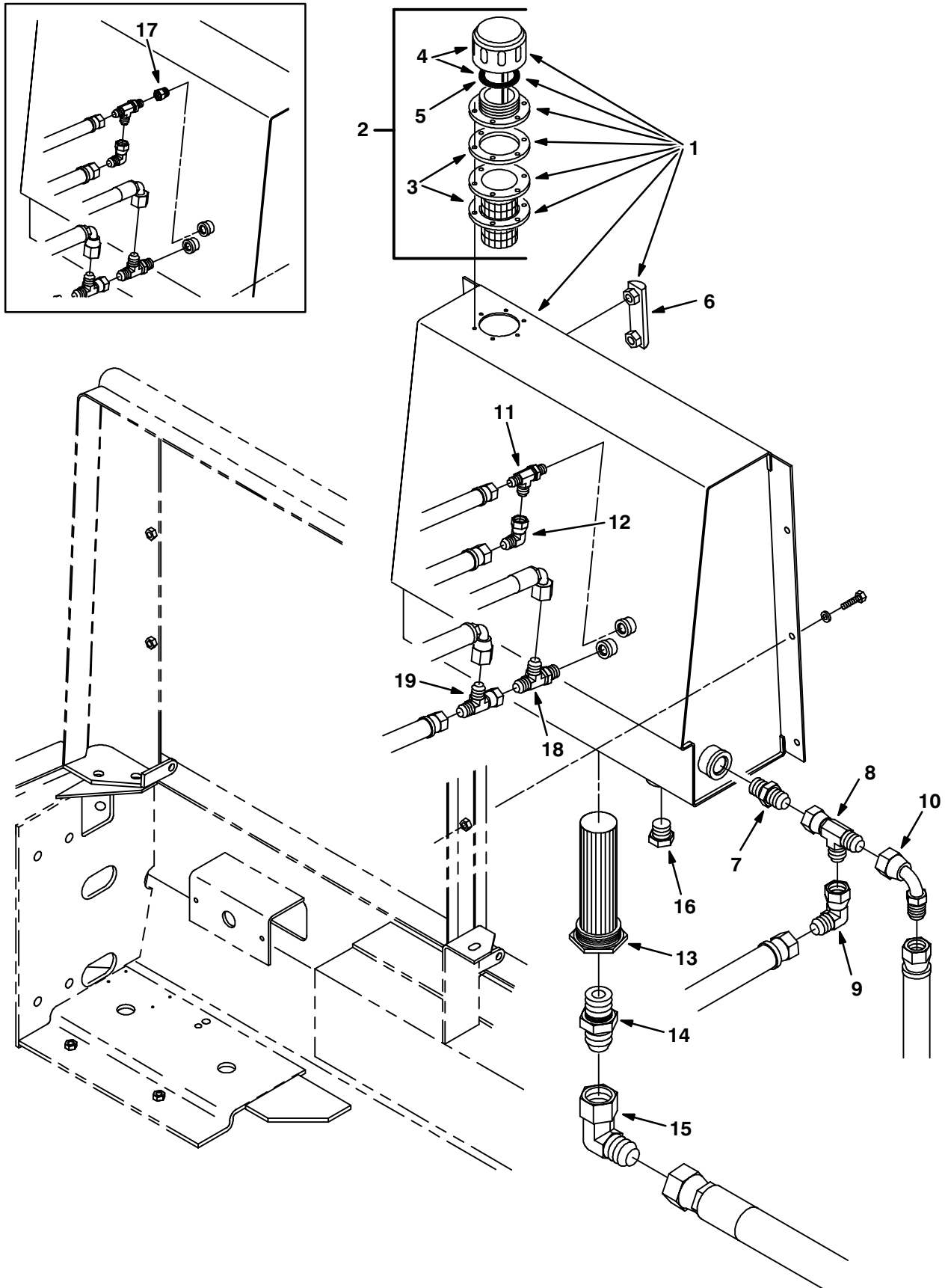

Fig. 53 – Hydraulic Reservoir Group

	Ref.	Tennant Part No.	Machine Serial Number	Description	Qty.
▽	1	63968	(000000–001150)	Tank Wldt, Hyd	1
▽	1	76906	(001151–)	Tank Wldt, Hydraulic	1
▽	2	34306	(000000–)	Breather, Hyd	1
	3	61288	(000000–)	Gasket, Hyd Tank Breather	2
	4	70072	(000000–)	Breather Cap and Gasket	1
	5	70006	(000000–)	Gasket, Hyd Cap	1
	6	65215	(000000–)	Gauge, Sight Lh	1
	7	42260	(000000–)	Ftg–Hyd Str Jm12/Om12	1
	8	40514	(000000–)	Ftg–Hyd Tee Jm12Jmjf	1
	9	35033	(000000–)	Ftg–Hyd E90 Jm12/Jf12	1
	10	57994	(000000–)	Ftg–Hyd E90 Special Jm12/Jf12	1
	11	34390	(000000–)	Ftg–Hyd Tee Jm04Jmom	1
	12	39210	(000000–)	Ftg–Hyd E90 Jm04/Jf04	1
	13	31613	(000000–)	Strainer–Hyd Suction 25–100–03	1
	14	58858	(000000–)	Ftg–Hyd Str Jm20/Om20	1
	15	19459	(000000–)	Ftg–Hyd E90	1
	16	33817	(000000–)	Ftg–Hyd Plg Om12	1
	17	87414	(000000–001150)	Ftg–Hyd Str Om/Of	1
	18	76316	(000000–)	Ftg–Hyd Tee Jm06Jmom	1
	19	42215	(000000–)	Ftg–Hyd Tee Jm06Jmjf	1

Fig. 54 – Hydraulic Solenoid Valve Group

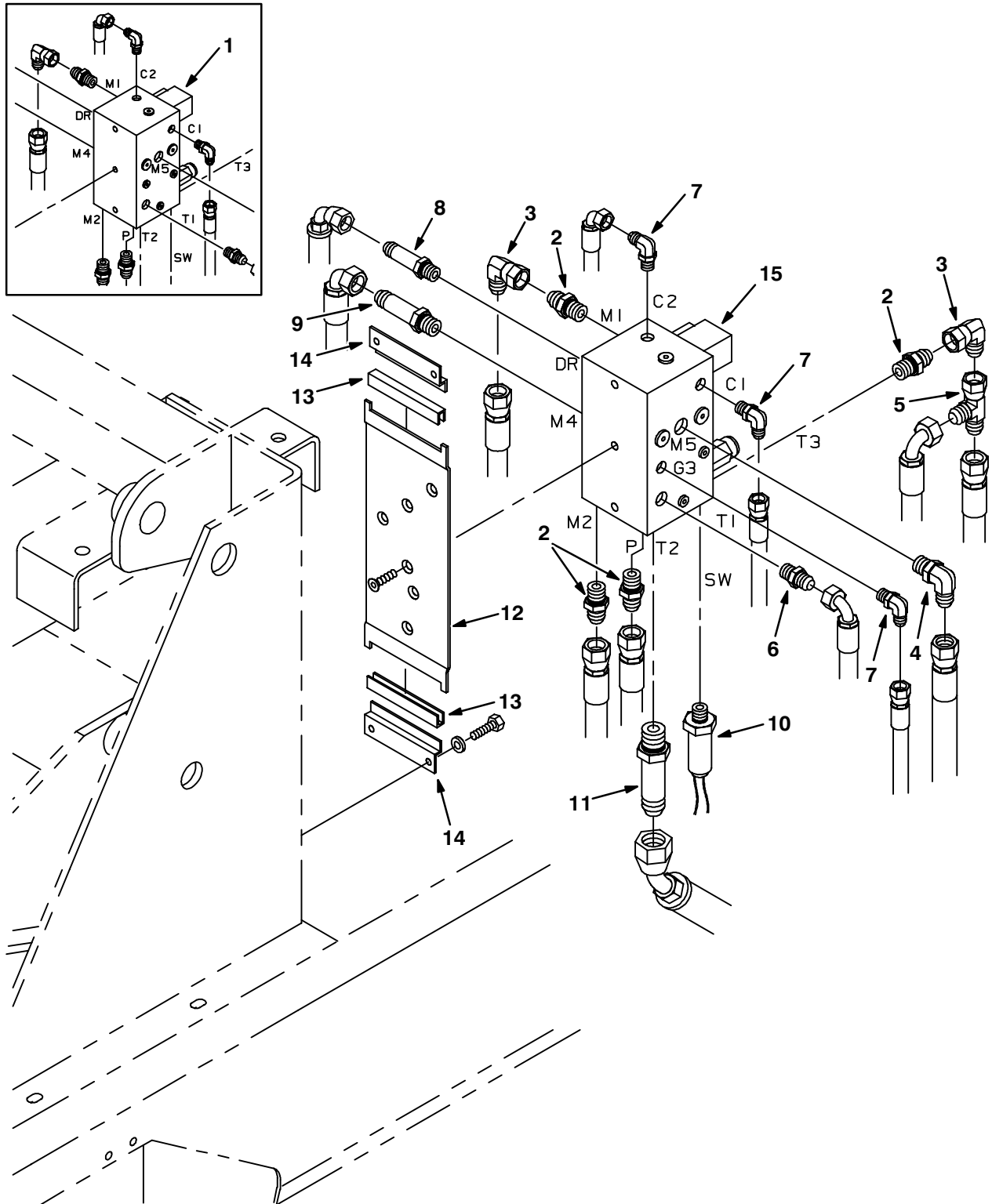

Fig. 54 – Hydraulic Solenoid Valve Group

Ref.	Tenant Part No.	Machine Serial Number	Description	Qty.
1	63527	(000000–001187)	Valve–Hyd, Solenoid (See Breakdowns)	1
2	44869	(000000–)	Ftg–Hyd Str Jm08/Om08	4
3	17980	(000000–)	Ftg–Hyd E90 Jm08/Jf08	2
4	44868	(000000–)	Ftg–Hyd E90 Jm08/Om08	1
5	45482	(000000–)	Ftg–Hyd Tee Jm08Jmjf	1
6	56690	(000000–)	Ftg–Hyd Str Jm06/Om06	1
7	77097	(000000–)	Ftg–Hyd E90 Jm04/Om04	3
8	59577	(000000–)	Ftg–Hyd Str Jm06Om06L	1
9	31605	(000000–)	Ftg–Hyd Str Jm08Om08L	1
10	70780	(000000–001146)	Switch Assy, Pressure, Hyd	1
10	77575	(001147–)	Switch Assy, Pressure, Hyd	1
11	57993	(000000–)	Ftg–Hyd Str Jm12Om12L	1
12	64228	(000000–)	Plate, Mtg, Valve, Solenoid	1
13	10911	(000000–)	Isolator, Vac Fan	2
14	06146	(000000–)	Bracket, Mounting	2
15	78996	(001188–001699)	Valve–Hyd, Solenoid (See Breakdowns)	1
15	84014	(001700–)	Valve–Hyd, Solenoid (See Breakdowns)	1

Fig. 55 – Hydraulic Lift Valve Group

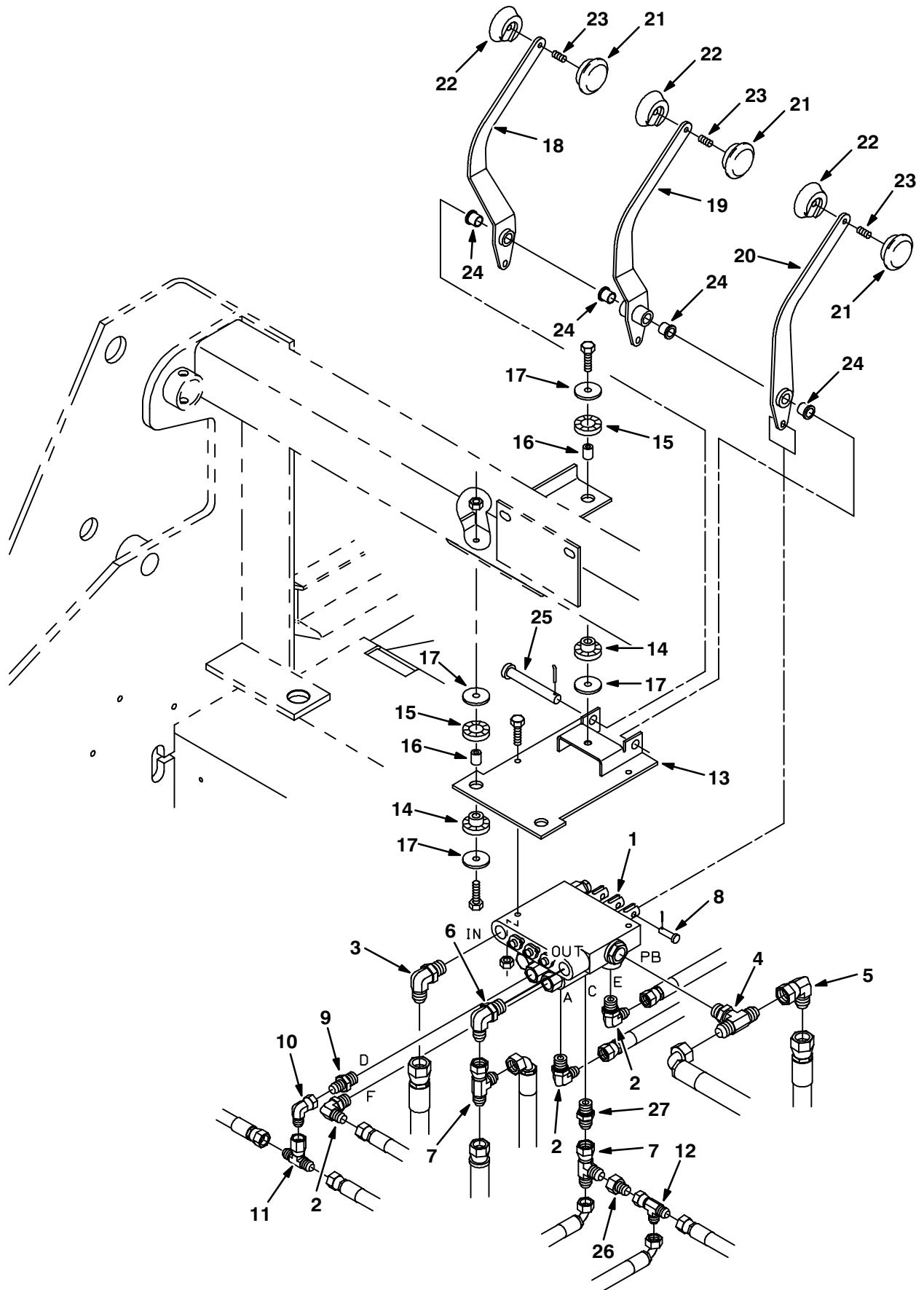

Fig. 55 – Hydraulic Lift Valve Group

Ref.	Tennant Part No.	Machine Serial Number	Description	Qty.
1	62567	(000000-001223)	Valve, Hyd, (Repl. by 77496) (See Breakdowns)	1
2	47638	(000000-001223)	Ftg-Hyd E90 Jm04/Om06	3
3	44868	(000000-001223)	Ftg-Hyd E90 Jm08/Om08	1
4	49933	(000000-001223)	Ftg-Hyd Tee Jm08OmJm	1
5	17980	(000000-001223)	Ftg-Hyd E90 Jm08/Jf08	1
6	47512	(000000-001223)	Ftg-Hyd E90 Jm06/Om08	1
7	42215	(000000-001223)	Ftg-Hyd Tee Jm06JmJf	2
8	14605	(000000-001223)	Pin,Clevis,0.25 Dia.X 0.75 Lg	3
9	55685	(000000-001223)	Ftg-Hyd Str Jm04/Om06	1
10	39210	(000000-001223)	Ftg-Hyd E90 Jm04/Jf04	1
11	57411	(000000-001223)	Ftg-Hyd Tee Jm04Jfjm	1
12	57988	(000000-001223)	Ftg-Hyd Tee Jm04Jmjf	1
13	64176	(000000-001223)	Bracket Wldt, Mtg, Valve	1
14	62173	(000000-001223)	Bushing, Isolator-Inner,Rbr.	3
15	62172	(000000-001223)	Ring	3
16	64905	(000000-001223)	Sleeve, .259B .38D .62 Dom	3
17	30013	(000000-001223)	Washer-Flt .31 Fender Pltd	6
18	64165	(000000-001223)	Handle Wldt, Rh	1
19	64166	(000000-001223)	Handle Wldt, Center	1
20	64175	(000000-001223)	Handle Wldt, Lh	1
21	64434	(000000-001223)	Knob	3
22	70827	(000000-001223)	Knob	3
23	70847	(000000-001223)	Scr Set M 6X1.0 20	3
24	36173	(000000-001223)	Bearing, Control Shaft	4
25	06474A	(000000-001223)	Pin,Clevis,0.50 Dia.X 3.50 Lg	1
26	47752	(000000-001223)	Ftg-Hyd Str Jm04/Jf06	1
27	56690	(000000-001223)	Ftg-Hyd Str Jm06/Om06	1

Fig. 56 – Hydraulic Lift Valve Group

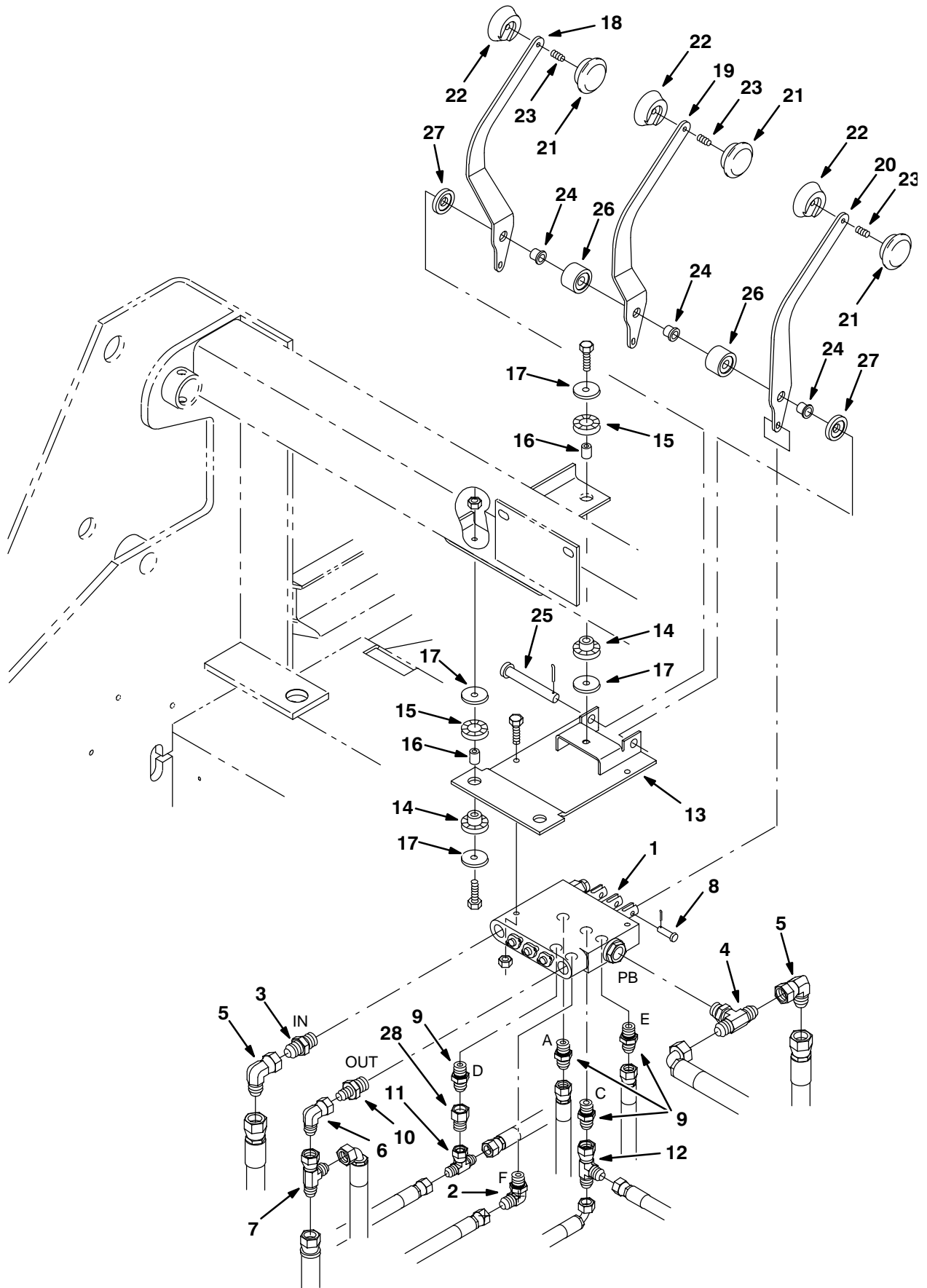

Fig. 56 – Hydraulic Lift Valve Group

Ref.	Tennant Part No.	Machine Serial Number	Description	Qty.
1	77495	(001224–)	Valve, Hyd Control Man (See Breakdowns)	1
2	47638	(001224–)	Ftg–Hyd E90 Jm04/Om06	1
3	44869	(001224–)	Ftg–Hyd Str Jm08/Om08	1
4	49933	(001224–)	Ftg–Hyd Tee Jm08Omjm	1
5	17980	(001224–)	Ftg–Hyd E90 Jm08/Jf08	2
6	47504	(001224–)	Ftg–Hyd E90 Jm06/Jf06	1
7	42215	(001224–)	Ftg–Hyd Tee Jm06Jmjf	2
8	77488	(001224–)	Pin, Clevis .18 Dia.X .62 Lg	3
9	55685	(001224–)	Ftg–Hyd Str Jm04/Om06	3
10	52402	(001224–)	Ftg–Hyd Str Jm06/Om08	1
11	57411	(001224–)	Ftg–Hyd Tee Jm04Jfjm	1
12	57988	(001224–)	Ftg–Hyd Tee Jm04Jmjf	1
13	77485	(001224–)	Bracket Wldt, Mounting, Valve	1
14	62173	(001224–)	Bushing, Isolator–Inner,Rbr.	3
15	62172	(001224–)	Ring	3
16	64905	(001224–)	Sleeve, .259B .38D .62 Dom	3
17	30013	(001224–)	Washer–Flt .31 Fender Pltd	6
18	77491	(001224–)	Handle, Rh	1
19	77492	(001224–)	Handle, Center	1
20	77493	(001224–)	Handle, Lh	1
21	64434	(001224–)	Knob	3
22	70827	(001224–)	Knob	3
23	70847	(001224–)	Screw Set M 6X1.020	3
24	36556	(001224–)	Bearing, Nylon .50B	3
25	06474A	(001224–)	Pin,Clevis,0.50 Dia.X 3.50 Lg	1
26	77498	(001224–)	Spacer, .90L	2
27	77499	(001224–)	Spacer, .25 L	2
28	16455	(001224–)	Ftg–Hyd Rst JM04/.047	1

Fig. 57 – Side Brush Group

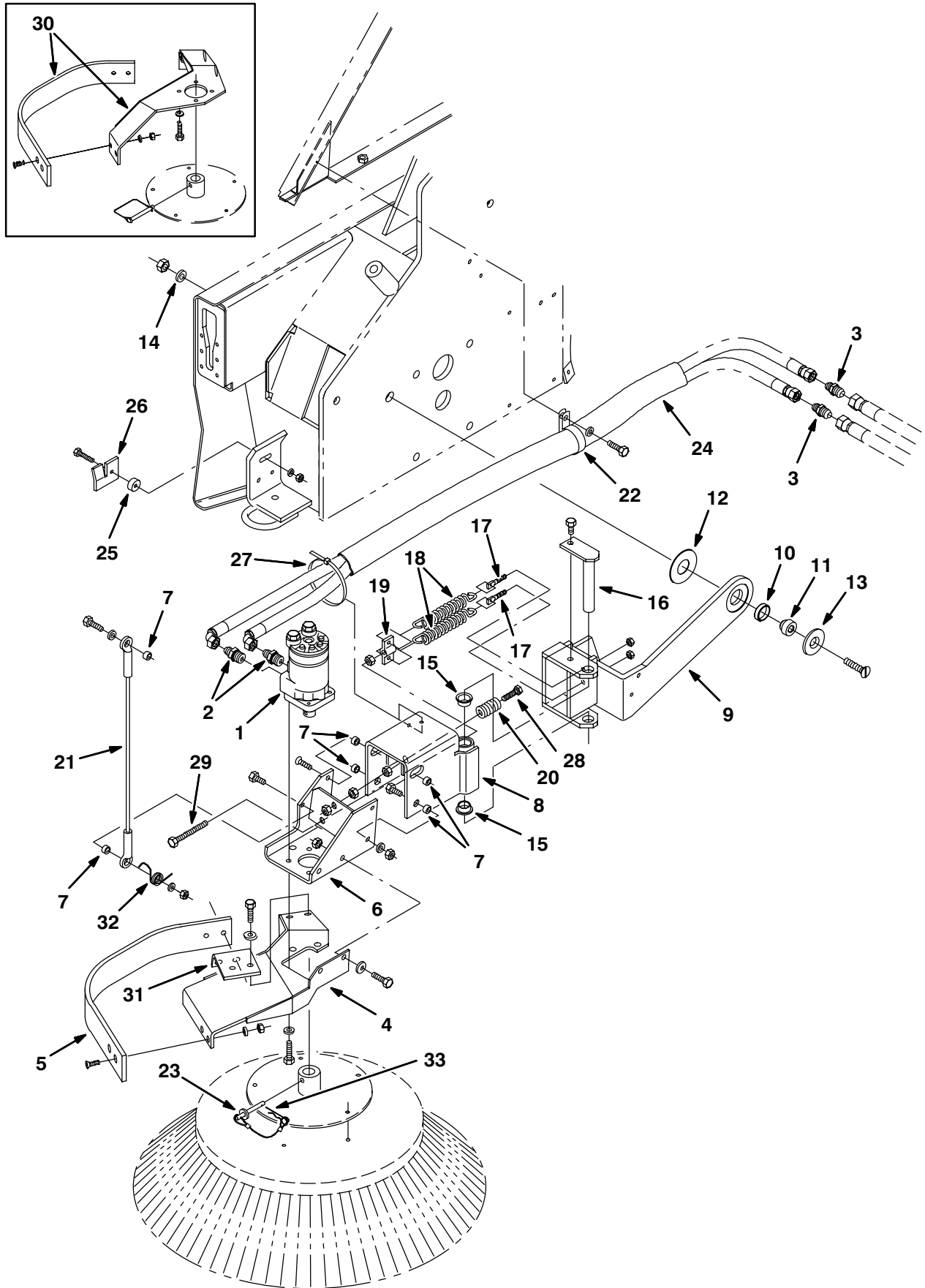

Fig. 57 – Side Brush Group

Ref.	Tennant Part No.	Machine Serial Number	Description	Qty.
1	62564	(000000-001477)	Motor, Hyd, (Repl. by 79781) (See Breakdowns)	1
1	79781	(001478-	Motor, Hyd, (See Breakdowns)	1
2	47508	(000000-	Ftg-Hyd Str Jm06/Om10	2
3	42207	(000000-	Ftg-Hyd Str Jm08/Jm06	2
4	21224	(001321-	Guard Wldt, Side Brush	1
5	21238	(001321-	Guard, Side Brush	1
6	65168	(000000-	Bracket, Mounting, Motor	1
7	65174	(000000-	Spacer	6
8	65170	(000000-	Bracket, Pivot	1
9	70521	(000000-	Bracket, Lift	1
10	70627	(000000-	Bearing	1
11	70526	(000000-	Shaft, Pivot	1
12	70524	(000000-	Washer, 1.300B 3.000	1
13	70525	(000000-	Spacer	1
14	36328	(000000-	Washer-Belleville .50 Pltd	1
15	04761	(000000-	Bearing, Flange .875 Bore	2
16	70431	(000000-	Pin	1
17	70626	(000000-	Bolt-Eye M8-1.25	2
18	65160	(000000-	Spring, Extension	2
19	65173	(000000-	Bracket, Spring	1
20	65180	(000000-	Spring, Comp	1
21	70532	(000000-	Cable, Retaining, Side Brush	1
22	86328	(000000-	Clamp, Cable 1.5 Dia	1
23	21035	(000000-	Pin Assy, .312X3.0 W/Lanyard	1
24	75028	(000000-	Sleeve, Nylon #27 65.0L	1
25	74059	(000000-	Spacer	1
26	74060	(000000-	Bracket, Angle	1
27	49263	(000000-	Tie Cable 3.00D Max 11.41Lg	1
28	06537	(000000-	Screw-Hex M10X1.5	1
29	76438	(000000-	Screw-Hex M10X1.5 90 Full Thd	1
30	21239	(000000-001320)	Guard, Side Brush Repl Kit Rh	1
31	21215	(001321-	Plate, Angle	1
32	79123	(000000-	Spring, Torsion , Rh	1
33	44906	(000000-	Pin,Hair Cotter #Lhcot-2,Leitk	1

Fig. 58 – Side Brush Lift Group

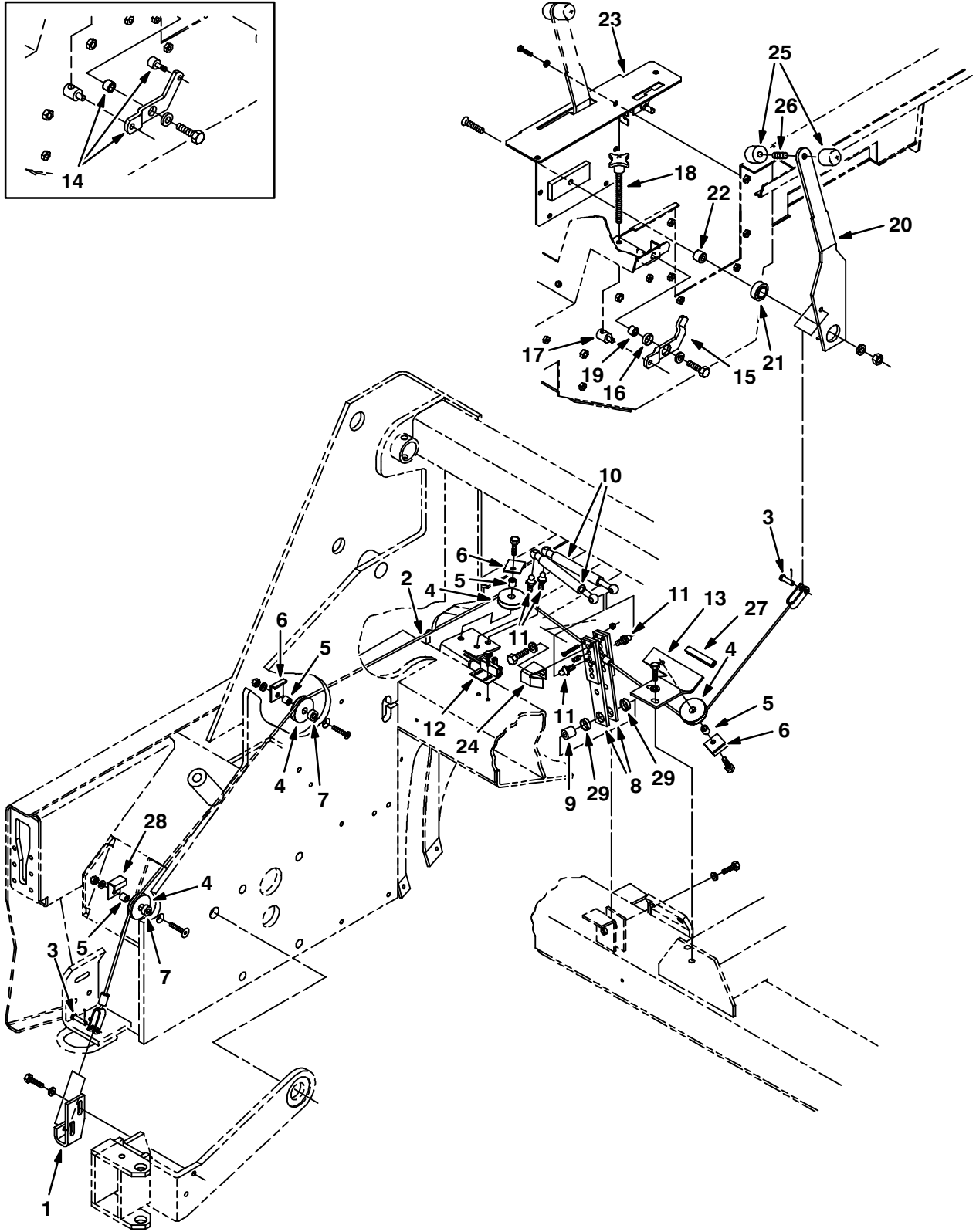

Fig. 58 – Side Brush Lift Group

Ref.	Tennant Part No.	Machine Serial Number	Description	Qty.
1	73856	(000000-001176)	Bracket, Channel	1
2	65294	(000000-001176)	Cable Assy, Side Brush, Lift	1
3	69582	(000000-001176)	Pin,Clevis,0.31 Dia X 1.00 Lg	2
4	58279	(000000-001176)	Pulley – Cable, 1.5 Dia	4
5	56624	(000000-001176)	Spacer, Pulley	4
6	54400	(000000-001176)	Angle, Cable Keeper	3
7	73737	(000000-001176)	Sleeve, .375B .75D .32 Stl	2
8	74031	(000000-001176)	Lever Wldt	2
9	73818	(000000-001176)	Sleeve, .375B .75D .75 Stl	1
10	73714	(000000-001176)	Gas Spring	2
11	58494	(000000-001176)	Stud, Ball, Gas Spring	4
12	59962	(000000-001176)	Switch, Roller	1
13	70715	(000000-001176)	Plate, Angle	1
14	76339	(000000-001065)	Side Brush Lever Adjustmt Kit	1
15	75893	(001066-001176)	Lever	1
16	74090	(001066-001176)	Bearing	1
17	70444	(000000-001176)	Rod, Cam Adjuster	1
18	54848	(000000-001176)	Knob, Adjusting	1
19	75894	(001066-001176)	Spacer	1
20	73860	(000000-001176)	Handle	1
21	54663	(000000-001176)	Bearing, Self Aligning	1
22	70720	(000000-001176)	Spacer	1
23	70861	(000000-001176)	Plate Wldt, Cover	1
24	76619	(000000-001176)	Bracket	1
25	75857	(000000-001176)	Knob, Handle, Threaded	2
26	75859	(000000-001176)	Rod-Thread, Full M10X1.5 X1.50	1
27	74068	(000000-001176)	Molding, Trim 3/16-5/16 2.75	1
28	74899	(000000-001176)	Bracket, Cable Keeper	1
29	74090	(000000-001176)	Bearing	2

Fig. 59 – Side Brush Lift Group

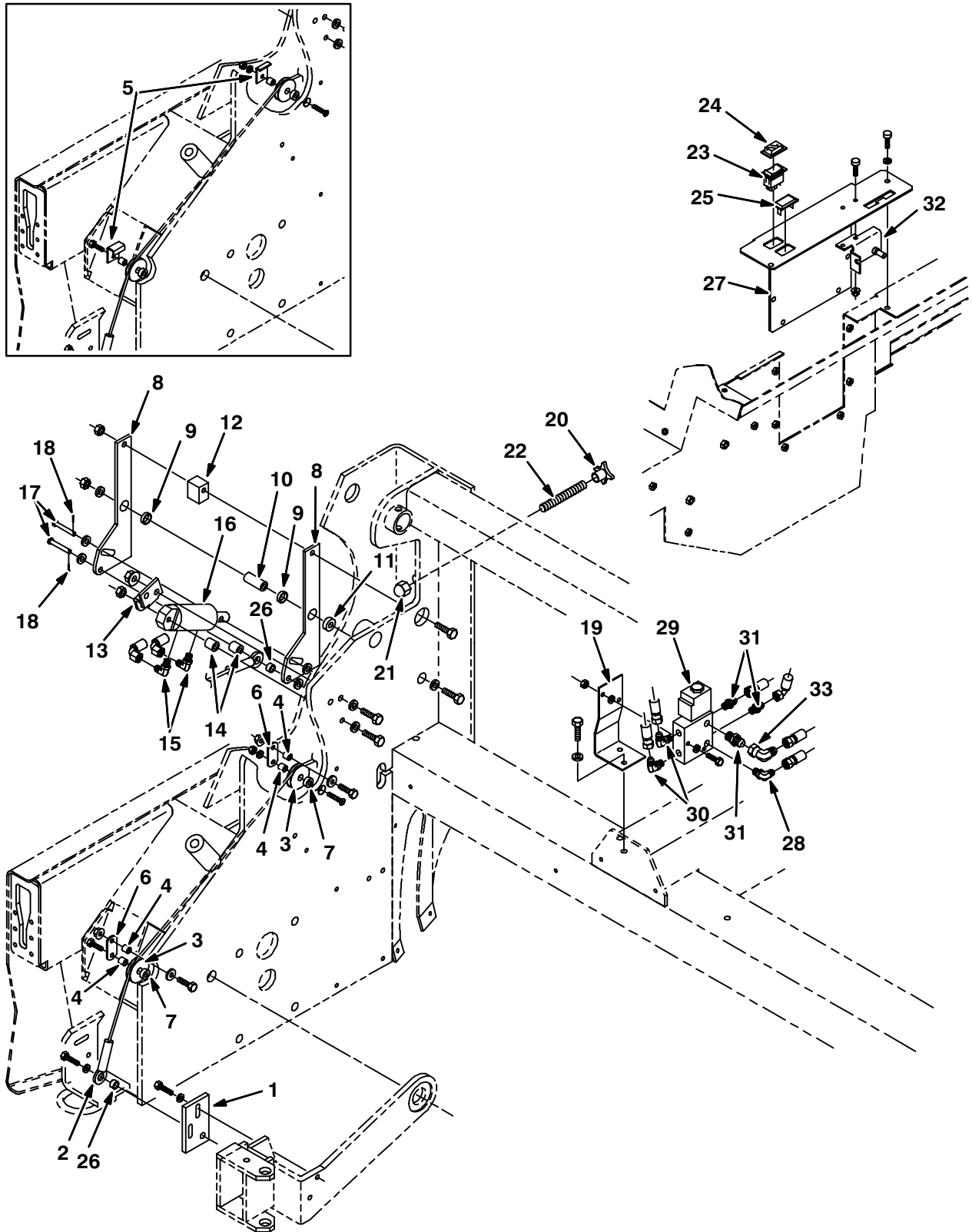

Fig. 59 – Side Brush Lift Group

Ref.	Tennant Part No.	Machine Serial Number	Description	Qty.
1	77669	(001177–)	Plate Wldt	1
2	77568	(001177–)	Cable, Side Brush, Lift	1
3	74391	(001177–)	Pulley Assy, Cable, 1.5 Dia	2
4	56624	(001177–)	Spacer, Pulley	4
5	79117	(001177–)	Retainer Replacement Kit	2
6	79115	(001177–)	Plate, Side Brush Roller	1
7	73737	(001177–)	Sleeve, .375B .75D .32 Stl	2
8	77584	(001177–)	Plate	2
9	74090	(001177–)	Bearing	2
10	77597	(001177–)	Sleeve, 0.406B 0.75D1.80 Stl	1
11	77727	(001177–)	Sleeve, .438B 1.00D .35 Stl	1
12	77459	(001177–)	Spacer	1
13	77601	(001177–)	Plate, Angle	1
14	77600	(001177–)	Sleeve,0.406B .750D .800 Stl	1
15	77097	(001177–)	Ftg–Hyd E90 Jm04/Om04	2
16	77599	(001177–)	Cylinder, Hyd 1.5B 1.5S 2500	1
17	51813	(001177–)	Pin,Clevis,0.37 Dia.X 2.12 Lg	2
18	08179	(001177–)	Pin, Cotter .094X1.00	2
19	21231	(001177–)	Plate	1
20	77605	(001177–)	Knob, Plastic	1
21	41131	(001177–)	Nut Low Crown .62–18	1
22	77682	(001177–)	Rod, Thread	1
23	65561	(001177–)	Switch Rocker Spst	1
24	57807	(001177–)	Cover, Rocker Switch Seal	1
25	57772	(001177–)	Plate–Cover	1
26	65174	(001177–)	Spacer	2
27	21113	(001177–)	Plate, Cover	1
28	56820	(001177–)	Ftg–Hyd E90	1
29	77771	(001177–001699)	Valve, Hyd Solenoid	1
29	84016	(001700–)	Valve, Hyd Solenoid (See Breakdowns)	1
30	77097	(001177–)	Ftg–Hyd E90 Jm04/Om04	2
31	56690	(001177–)	Ftg–Hyd str	3
32	77693	(001177–)	Plate Wldt, Angle	1
33	47504	(001177–)	Ftg–Hyd E90	1

Fig. 60 – Main Brush Drive Group

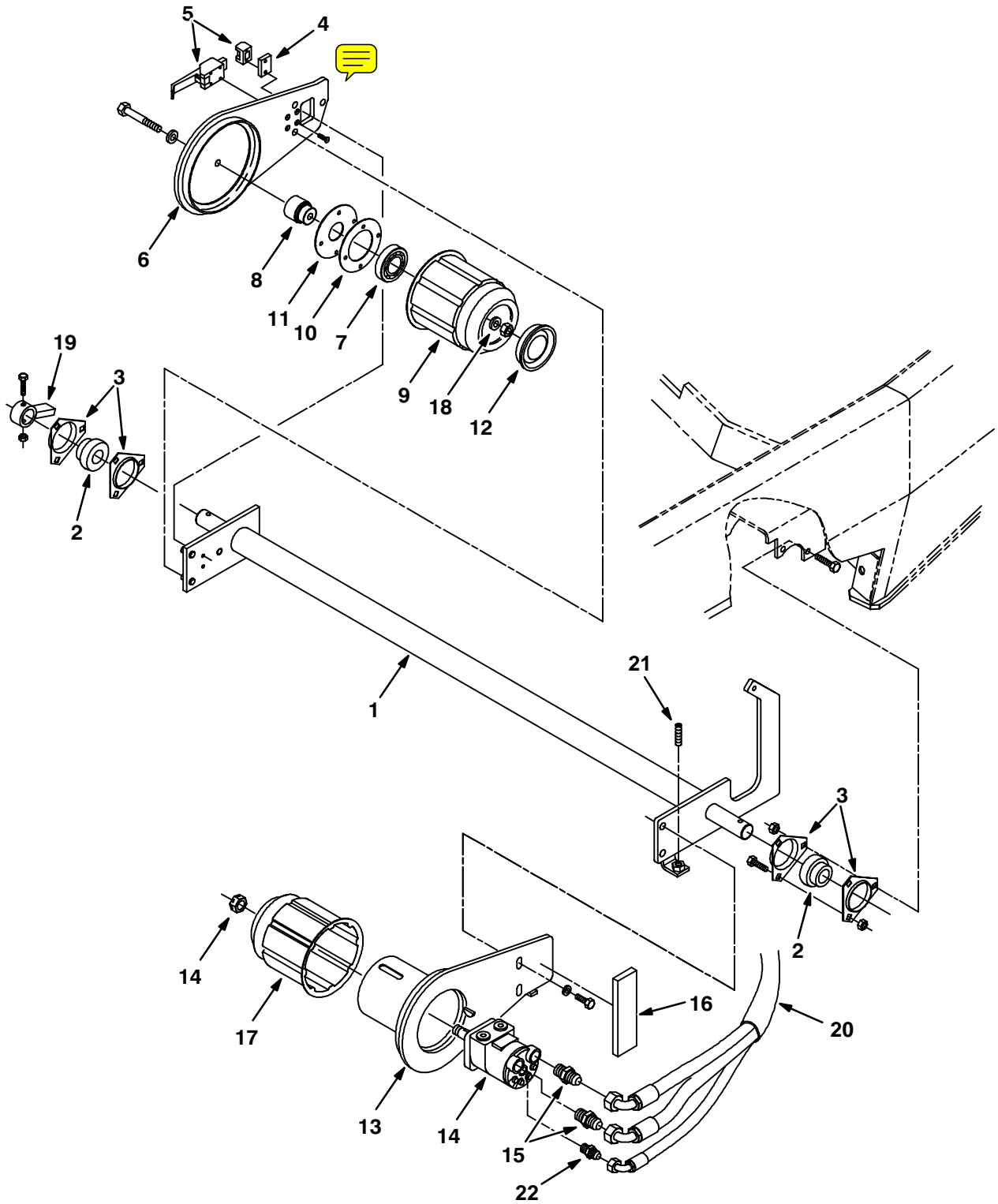

Fig. 60 – Main Brush Drive Group

Ref.	Tennant Part No.	Machine Serial Number	Description	Qty.
1	63436	(000000–)	Shaft Wldt, Main Brush	1
2	51448	(000000–)	Bearing&Clr ,1.25B 2.44D 1.41W	2
3	51449	(000000–)	Flange,Brg,3 Hole	4
4	63541	(000000–)	Plate, Mtg, Latch	1
5	54878	(000000–)	Latch	1
6	63449	(000000–)	Arm Wldt, M Br, Idler	1
7	24899	(000000–)	Bearing–Ball,1.38B 2.83D 0.67W	1
8	30251	(000000–)	Shaft, Idler	1
9	55779	(000000–)	Plug Wldt, Idler	1
10	30252	(000000–)	Strip, Retainer, Bearing	1
11	30253	(000000–)	Plate, Seal	1
12	30255	(000000–)	Plug, Tube	1
13	63450	(000000–)	Arm Wldt, M Br, Motor	1
14	53434	(000000–)	Motor–Hyd Gear In (See Breakdowns)	1
15	44869	(000000–)	Ftg–Hyd Str Jm08/Om08	2
16	60732	(000000–)	Seal, Foam	1
17	87631	(000000–)	Plug Weld, Brush Drive, Sweep	1
18	51564	(000000–)	Washer, .531B 1.75D .12Cr.Znc	1
19	64811	(000000–)	Bar Wldt, Brush Pressure	1
20	34330	(000000–)	Sleeve, Hyd 30"	1
21	75612	(000000–)	Screw, Set	1
22	55586	(000000–)	Ftg–Hyd Str	1

Fig. 61 – Main Brush Lift Group

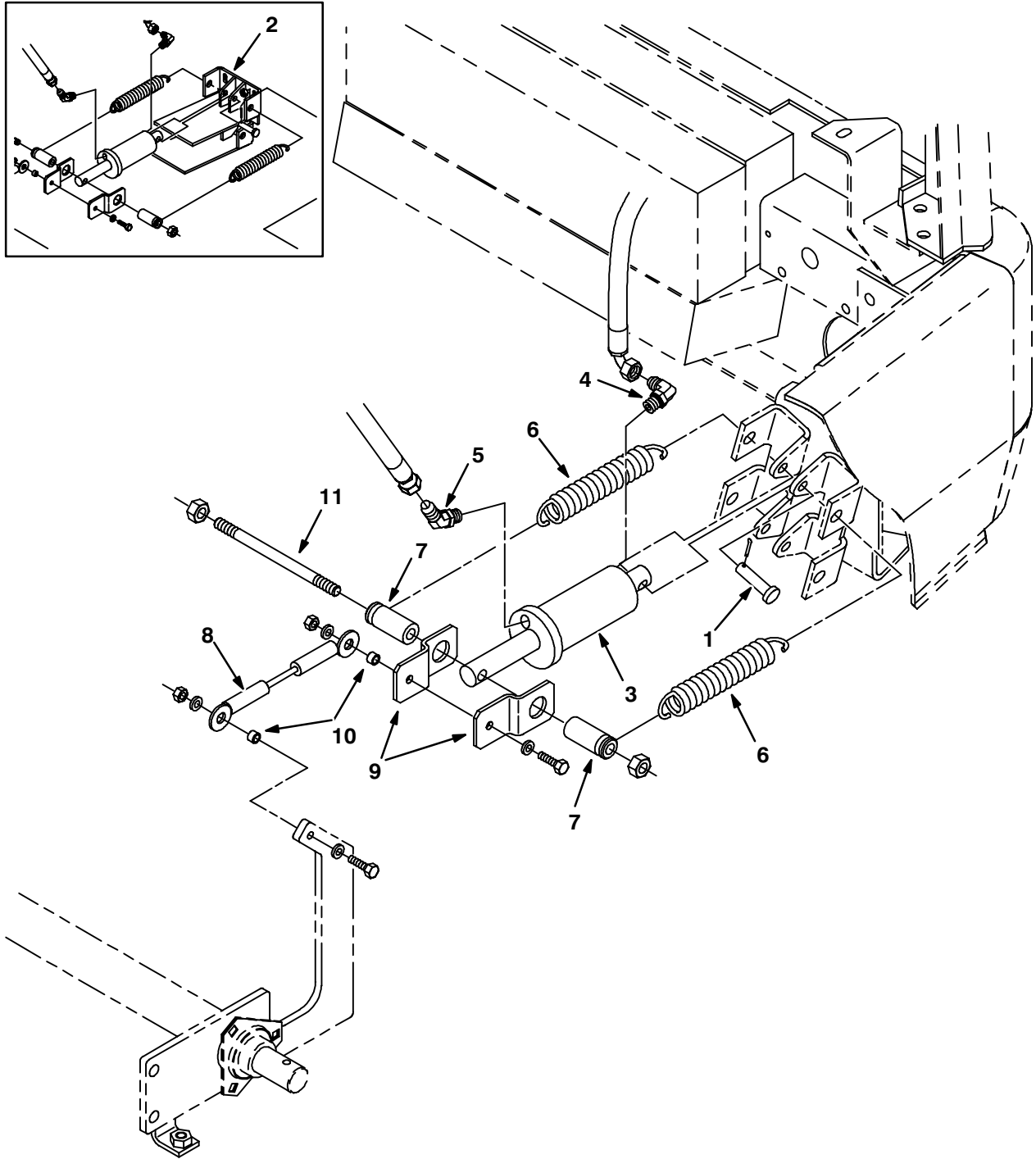

Fig. 61 – Main Brush Lift Group

Ref.	Tennant Part No.	Machine Serial Number	Description	Qty.
1	51534	(000000–)	Pin,Clevis,0.50 Dia.X 2.00 Lg	1
2	64034	(000000–001131)	Bracket Wldt, Lift, Cylinder	1
3	54096	(000000–)	Cylinder, Hyd	1
4	77097	(000000–)	Ftg–Hyd E90 Jm04/Om04	1
5	34359	(000000–)	Ftg–Hyd E45 Jm04/Om04	1
6	33404	(000000–)	Spring, Tension	2
7	64132	(000000–)	Tube, Retainer, Spring	2
8	64233	(000000–)	Cable, Lift, Main Brush	1
9	65248	(000000–)	Bracket, Brush Lift, Main	2
10	65249	(000000–)	Tube, Spacer, Brush Lift	2
11	70583	(000000–)	Rod, Threaded .50–13	1

Fig. 62 – Main Brush Adjustment Group

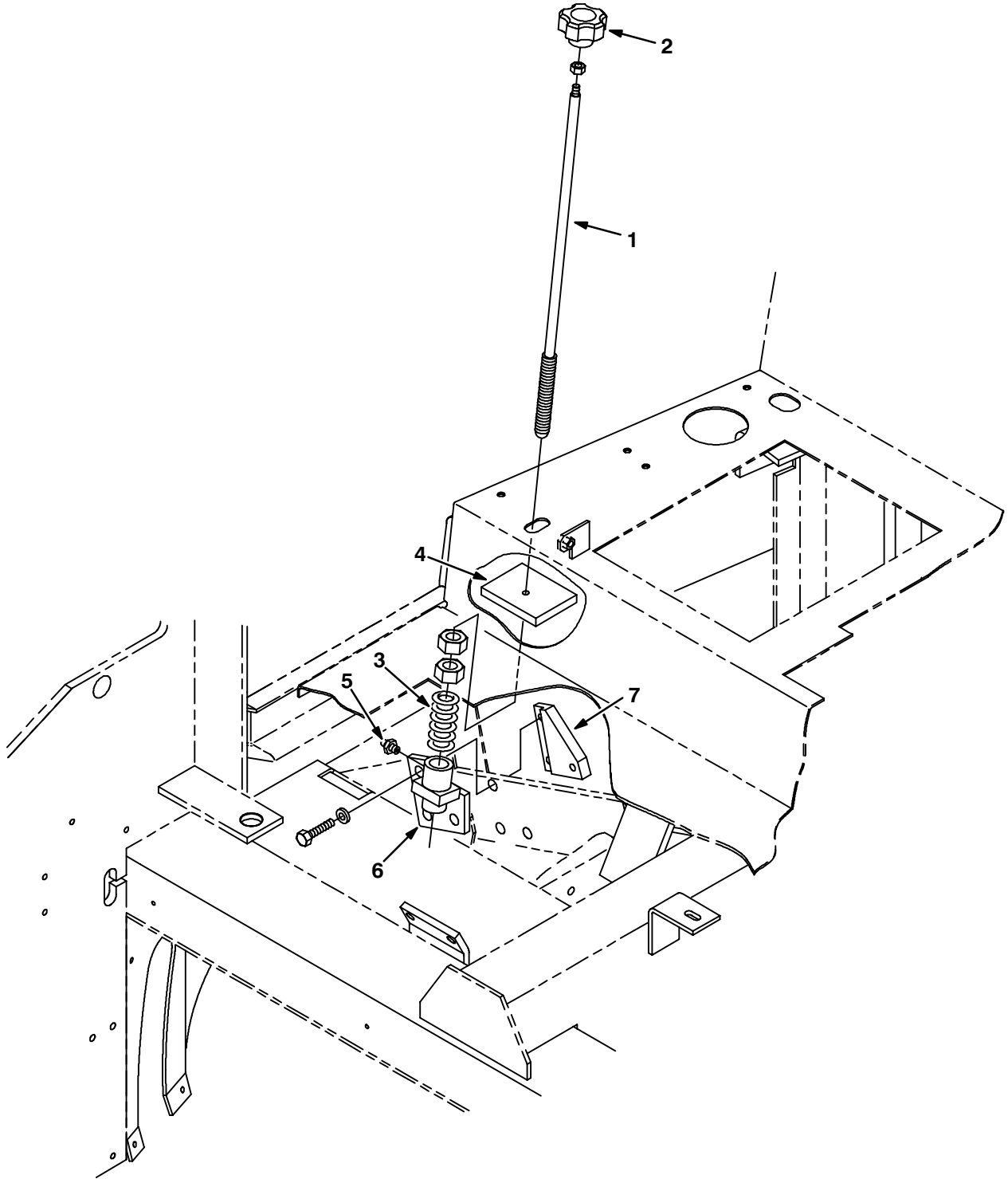

Fig. 62 – Main Brush Adjustment Group

Ref.	Tennant Part No.	Machine Serial Number	Description	Qty.
1	64812	(000000–001164)	Rod Wldt, Brush Pressure	1
2	41341	(000000–001164)	Knob, Plastic	1
3	51693	(000000–001164)	Sprng,Comp,0.87Idx.10Wire 2.5L	1
4	73762	(000000–001157)	Seal, Rod, Brush Pressure	1
5	50270	(000000–001164)	Ftg, Grease .12Nptf–Str	1
6	74005	(000000–001164)	Plate Wldt, Adj, Brush	1
7	74025	(000000–001164)	Plate, Tapped	1

Fig. 63 – Main Brush Adjustment Group

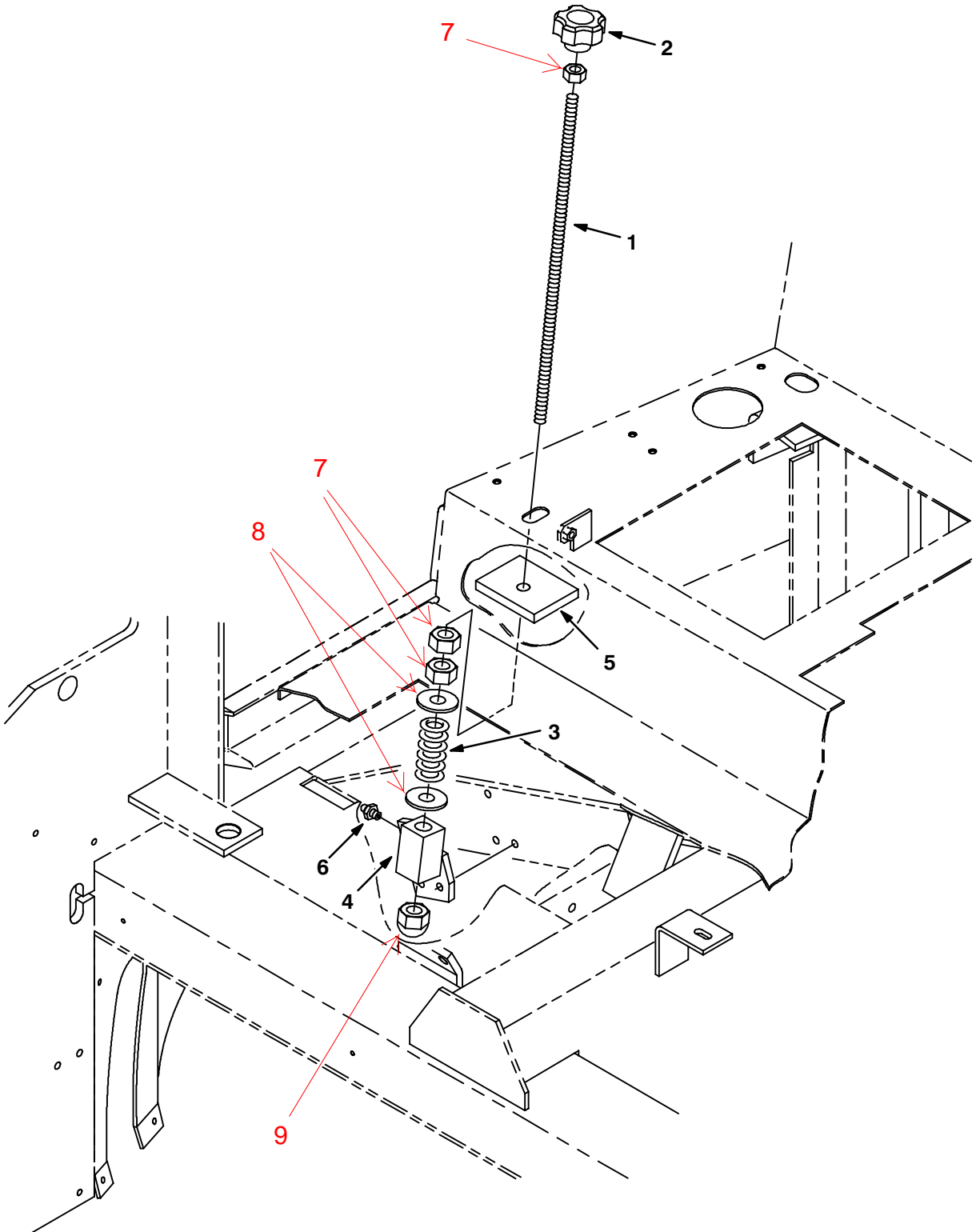

Fig. 63 – Main Brush Adjustment Group

Ref.	Tennant Part No.	Machine Serial Number	Description	Qty.
1	77578	(001165–) Rod, Thread	1
2	77605	(001165–) Knob, Plastic	1
3	51693	(001165–) Sprng,Comp,0.87Idx.10Wire 2.5L	1
4	77580	(001165–) Plate, Adj, Brush	1
5	79028	(001158–) Seal, Rod, Adjuster	1
6	11716	(001165–) Ftg, Grease.12 Npt 45 .88L	1
7	77583	(001165-) Nut, Hex Std	3
8	15331	(001165-) Washer, Flat	2
9	41131	(001165-) Nut, Low Crown	1

Fig. 64 – Vacuum Fan Impeller Group

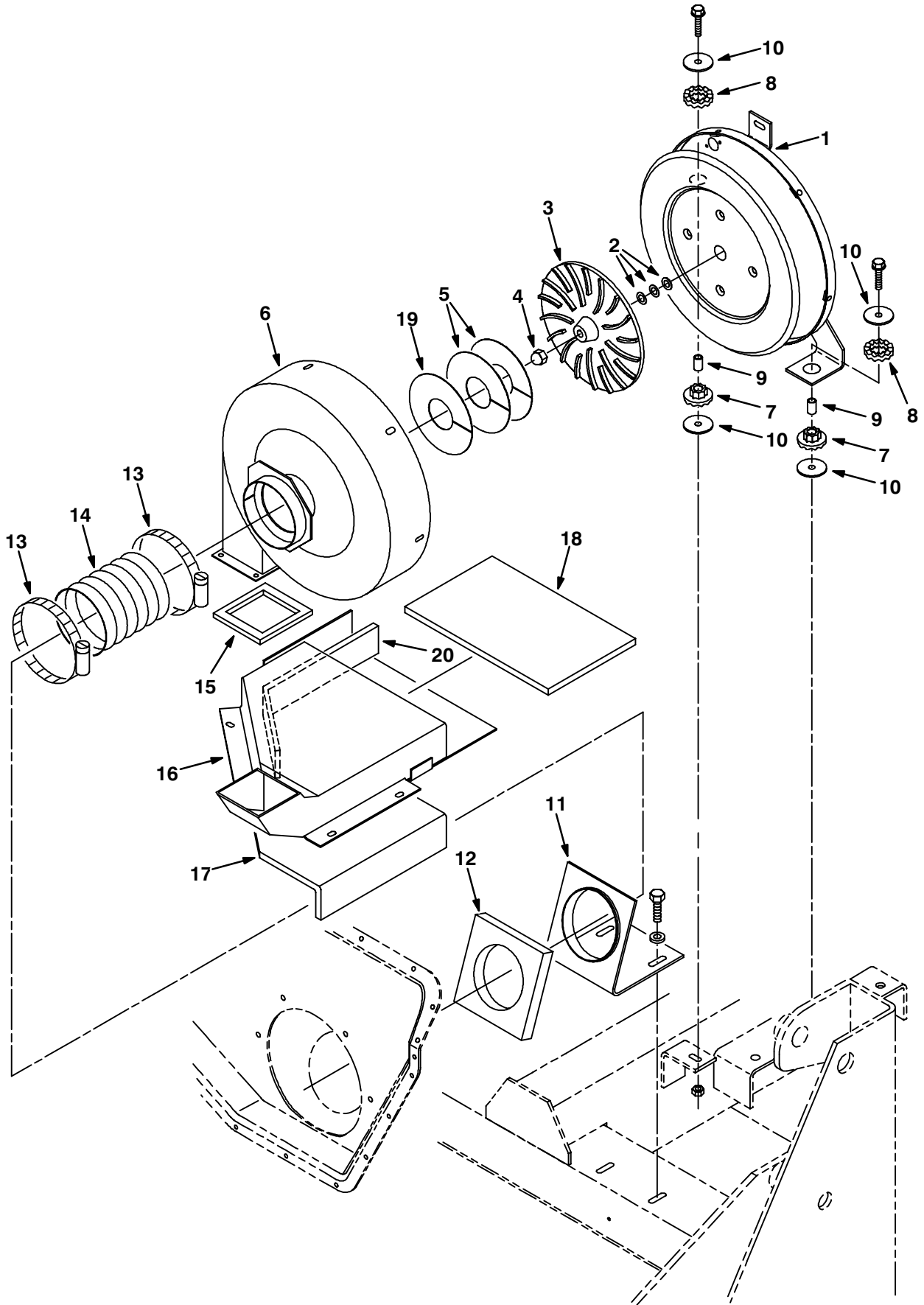

Fig. 64 – Vacuum Fan Impeller Group

Ref.	Tennant Part No.	Machine Serial Number	Description	Qty.
1	64648	(000000-001204)	Housing Wldt, Vac Fan, Rear	1
2	75456	(000000-001204)	Shim,.003Th 0.88Odx0.506ld	1
2	75456-1	(000000-001204)	Shim,.005Th 0.88Odx0.506ld	1
2	75456-2	(000000-001204)	Shim,.010Th 0.88Odx0.506ld	1
2	75456-3	(000000-001204)	Shim,.020Th 0.88Odx0.506ld	3
2	75456-4	(000000-001204)	Shim,.060Th 0.880Dxo.506ld	3
3	03922	(000000-001204)	Impeller 9.5 Dia. 18 Blade Mac	1
4	41130	(000000-001204)	Nut-Low Crown .50-20 Pltd	1
5	57543	(000000-001204)	Shim, Vac Fan Assy	2
6	70784	(000000-001204)	Housing Wldt, Vac Fan, Front	1
7	64621	(000000-001204)	Bushing, Isolator	2
8	64618	(000000-001204)	Ring, Isolator, Outer, Rbr	2
9	64299	(000000-001204)	Spacer	2
10	58228	(000000-001204)	Plate, Spring – Side Brush	4
11	70825	(000000-001204)	Bracket Wldt, Fan Inlet	1
12	74023	(000000-001204)	Gasket, Duct	1
13	73685	(000000-001204)	Clamp, Worm Drive 3.62-5.50	2
14	73646	(000000-001204)	Hose, Fan Inlet	1
15	73650	(000000-001204)	Insulation, Acoustic, Fan	1
16	70652	(000000-001204)	Panel Wldt, Duct, Vac Fan	1
17	70857	(000000-001204)	Insulation, Acoustic, Vac Fan	1
18	74009	(000000-001204)	Insulation, Acoustic, Vac Fan	1
19	31504	(000000-001204)	Shim, Vac Fan Assy	1
20	70877	(000000-001204)	Insulation, Acoustic, Vac Fan	1

Fig. 65 – Vacuum Fan Impeller Group

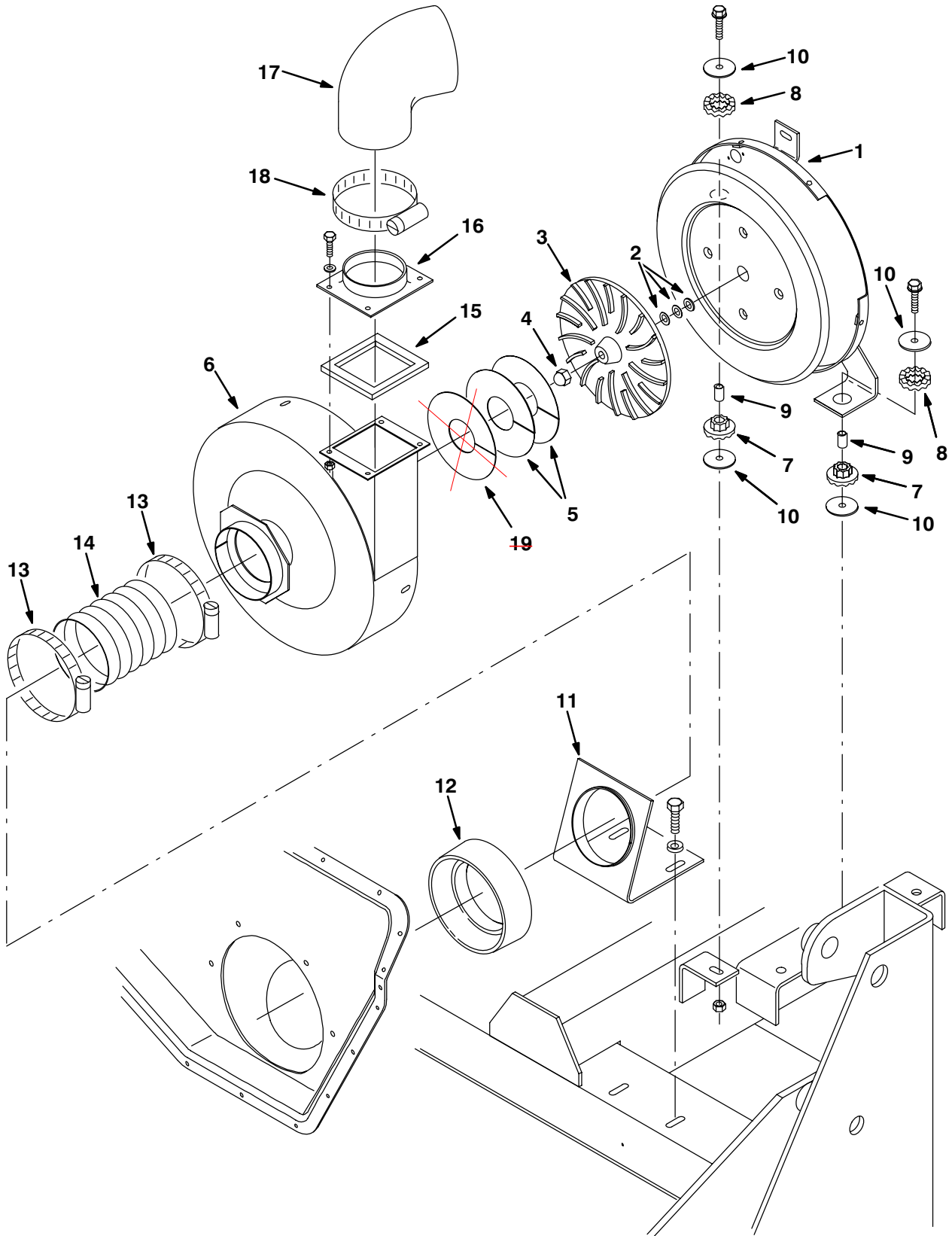

Fig. 65 – Vacuum Fan Impeller Group

Ref.	Tenant Part No.	Machine Serial Number	Description	Qty.
1	77531	(001205–)	Housing Wldt, Vac Fan, Rear	1
2	75456	(001205–)	Shim .003Th 0.88Odx0.506ld	1
2	75456–1	(001205–)	Shim .005Th 0.88Odx0.506ld	1
2	75456–2	(001205–)	Shim .010Th 0.88Odx0.506ld	1
2	75456–3	(001205–)	Shim .020Th 0.88Odx0.506ld	3
2	75456–4	(001205–)	Shim .060Th 0.880Dxo.506ld	3
3	03922	(001205–)	Impeller 9.5 Dia. 18 Blade Mac	1
4	41130	(001205–)	Nut–Low Crown .50–20 Pltd	1
5	58114	(001205–)	Fan, Repair Kit, Reassembly	1
6	77532	(001205–)	Housing Wldt, Vac Fan, Front	1
7	64621	(001205–)	Bushing, Isolator	2
8	64618	(001205–)	Ring, Isolator, Outer Rbr	2
9	64299	(001205–)	Spacer	2
10	58228	(001205–)	Plate, Spring – Side Brush	4
11	70825	(001205–)	Bracket Wldt, Fan Inlet	1
12	79122	(001205–)	Gasket, Vac Fan	1
13	73685	(001205–)	Clamp–Wormdrive, 3.62– 5.50D	2
14	73646	(001205–)	Hose, Fan Inlet	1
15	73650	(001205–)	Insulation, Acoustic, Fan	1
16	77553	(001205–)	Plate, Vac Fan	1
17	77591	(001205–)	Elbow, 90, Rubber	1
18	23498	(001205–)	Clamp–Wormdrive, 2.63– 4.50D	1
19	31504	(001205–)	Shim–Vac Fanassy	4

Fig. 66 – Vacuum Fan Motor Group

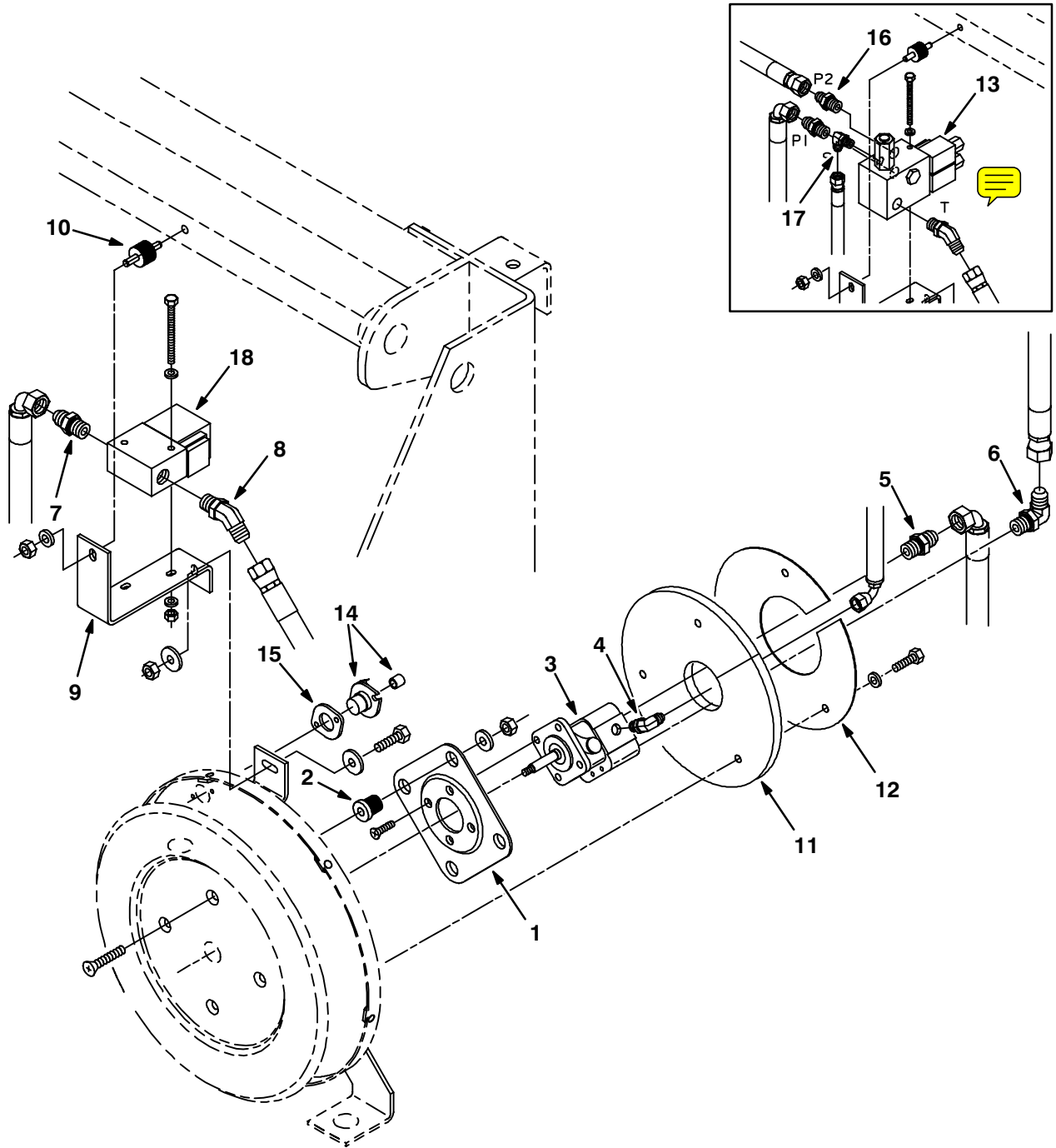

Fig. 66 – Vacuum Fan Motor Group

Ref.	Tenant Part No.	Machine Serial Number	Description	Qty.
1	54275A	(000000–)	Bracket, Mounting Motor	1
2	54274	(000000–)	Isolator–Vibration,60 Lb.Ratng	4
3	19117	(000000–)	Motor–Hyd Gear Ex (See Breakdowns)	1
4	77097	(000000–)	Ftg–Hyd E90 Jm04/Om04	1
5	56692	(000000–)	Ftg–Hyd Str Jm08/Om10	1
6	56821	(000000–)	Ftg–Hyd E90 Jm08/Om10	1
7	44869	(000000–)	Ftg–Hyd Str Jm08/Jm08	1
8	42226	(000000–)	Ftg–Hyd E45 Jm08/Om08	1
9	70775	(000000–)	Bracket, Mtg, Valve	1
10	05611	(000000–)	Isolator, Vibration	1
11	70810	(000000–)	Insulation, Acoustic, Vac Fan	1
12	70790	(000000–)	Plate, Retainer, Foam	1
13	65239	(000000–001102)	Valve–Hyd, Solenoid	1
14	02713	(000000–)	Thermostat Assembly, 155 Deg	1
15	82733	(000000–)	Gasket, Fire Switch	1
16	52402	(000000–001102)	Ftg–Hyd Str Jm08/Jm06	1
17	77097	(000000–001102)	Ftg–Hyd E90 Jm04/Om04	1
18	65391	(001103–001699)	Valve–Hyd, Solenoid (See Breakdowns)	1
18	84015	(001700–)	Valve–Hyd, Solenoid (See Breakdowns)	1

Fig. 67 – Steering Group

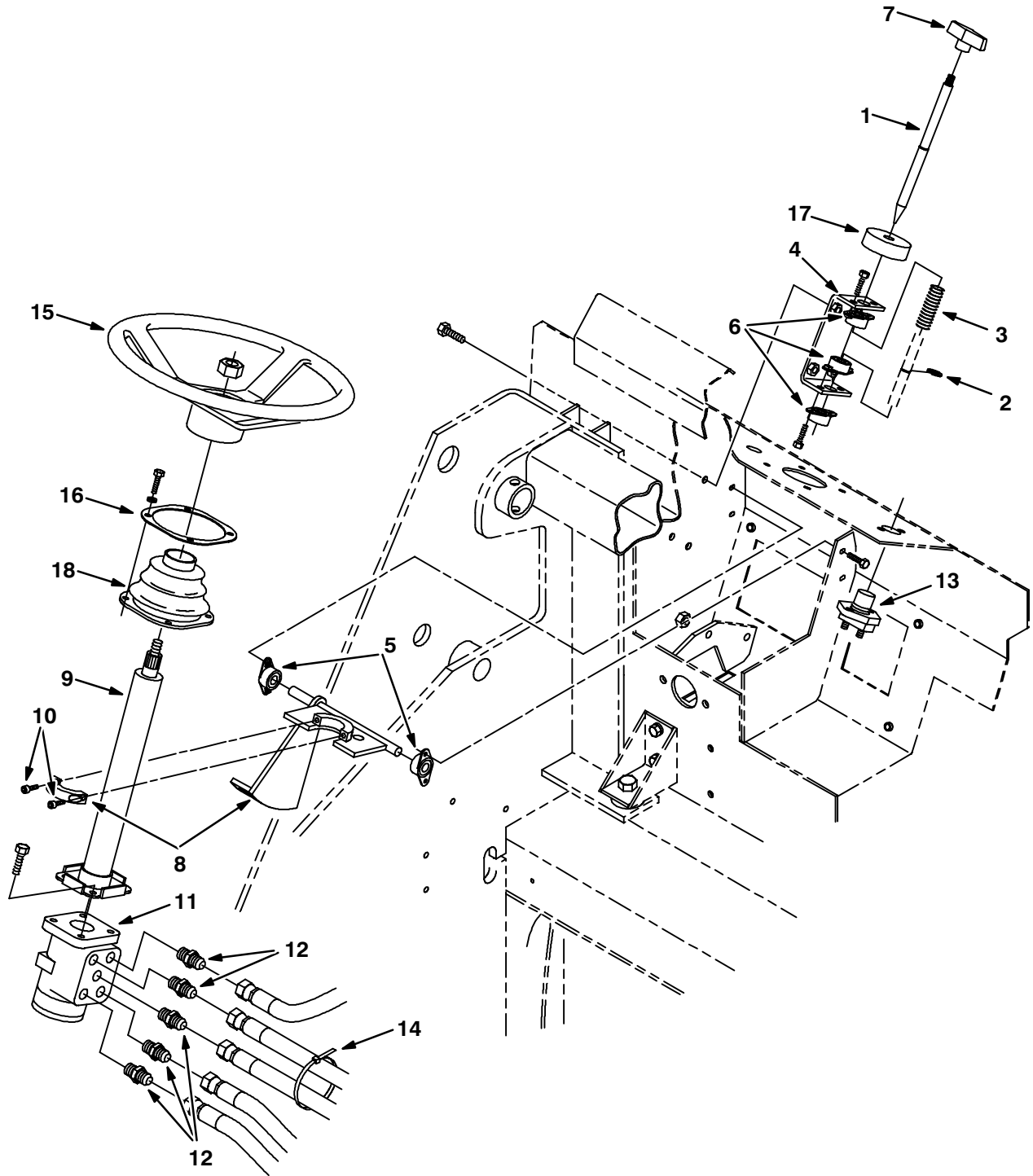

Fig. 67 – Steering Group

Ref.	Tennant Part No.	Machine Serial Number	Description	Qty.
1	64651	(000000–)	Rod, Latch, Steering, Tilt	1
2	70717	(000000–)	Ring,Retain,Ex,0.50Od,Heavy Dt	1
3	22290	(000000–)	Sprng,Comp,0.62Idx.06Wire 2.3L	1
4	64655	(000000–)	Channel, Mtg, Steering Latch	1
5	70709	(000000–)	Bearing, Flange .500B	2
6	47585	(000000–)	Bearing–Flange,2 Hole 0.50Bore	3
7	04706	(000000–)	Handle, Lift, Brush	1
8	64586	(000000–)	Bracket Wldt, Steering Tilt	1
9	64631	(000000–)	Column, Steering 12”	1
10	10829	(000000–)	Scr Soc .38–16X0.75	2
11	62565	(000000–001148)	Steer Control, Hyd	1
11	65242	(001149–)	Steer Control, Hyd	1
12	56690	(000000–)	Ftg–Hyd Str Jm06/Om06	5
13	44078	(000000–)	Switch, Pushmom, Spst100A 12V	1
14	49263	(000000–)	Tie, Cable 3.00D Max 11.41Lg	3
15	56398	(000000–)	Wheel, Steering	1
16	70623	(000000–)	Plate, Mtg, Steering Boot	1
17	75968	(000000–)	Seal, Bearing	1
18	70622	(000000–)	Seal, Boot, Steering Column	1

Fig. 68 – Instrument Panel Assembly

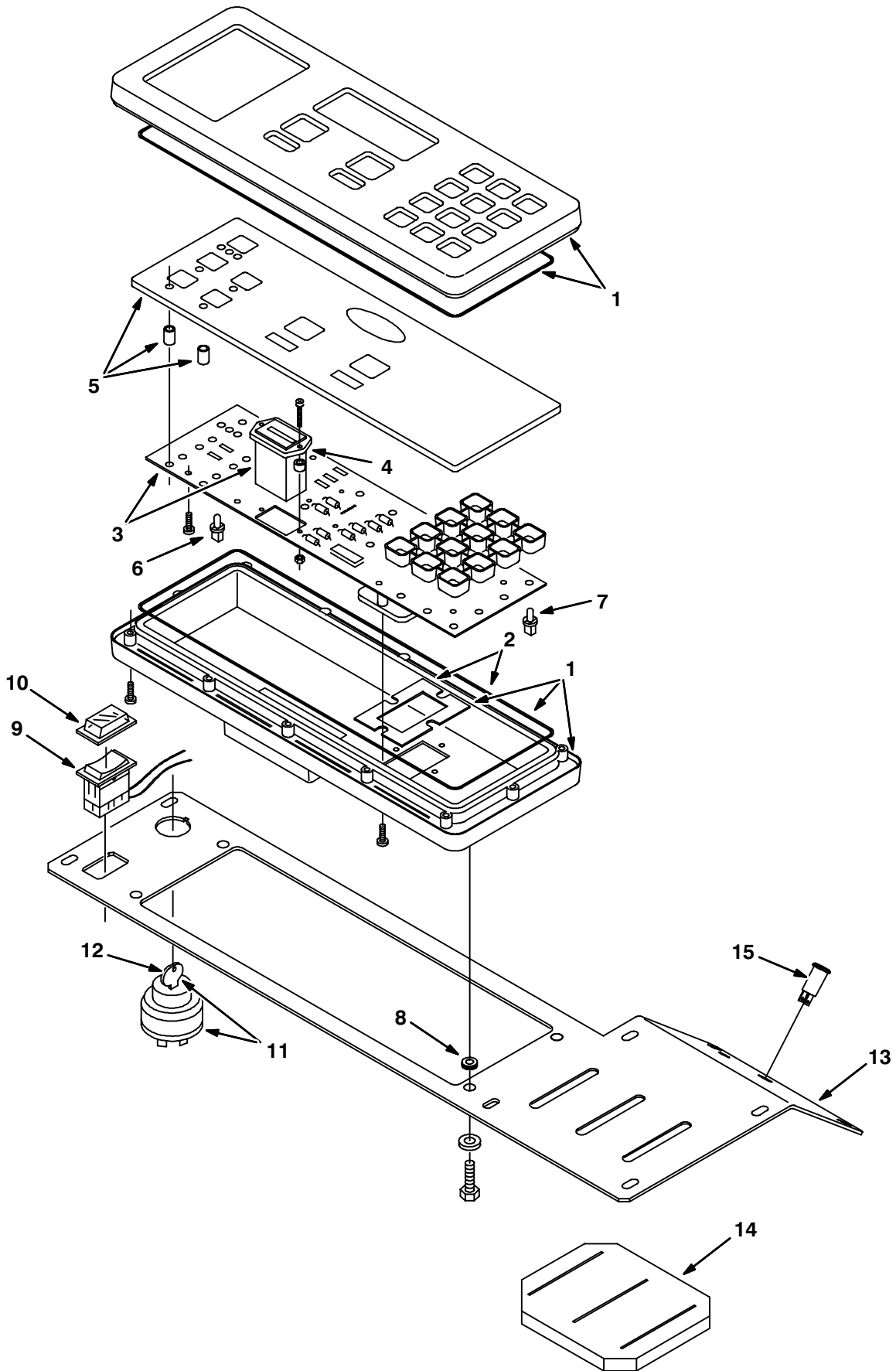

Fig. 68 – Instrument Panel Assembly

Ref.	Tennant Part No.	Machine Serial Number	Description	Qty.	
▽	59970	(000000–) Replm Kit, Instr Panel	1	
1	59976	(000000–) Replm Kit, Case	1	
2	59977	(000000–) Replm Kit, Seal	1	
▽	3	59974	(000000–) Replm Kit, Cir Board	1
4	59978	(000000–) Replm Kit, Hourmeter	1	
5	59979	(000000–) Replm Kit, Touch Panel	1	
6	59971	(000000–) Replm Kit, Lamp, Backlighting (Set of 8)	2	
7	56346	(000000–) Replm Kit, Lamp, Fault (Set of 8)	1	
8	10632–5	(000000–) Grommet,Rbr,0.25ld,For .09Matl	4	
9	61969	(000000–) Switch, Rocker, Dpdt	1	
10	57807	(000000–) Cover, Rocker Switch Seal	1	
▽	11	87536	(000000–) Switch Ignition	1
12	87866	(000000–) Key Set,Switch Ku	1	
13	72100	(000000–) Replm Kit, Sun Shield	1	
13	14 65245	(000000–) Panel, Cover, Dash	1	
14	15 70637	(000000–) Seal, Handle, Valve	1	
15	16 34820	(000000–) IndicatorLight, Glow Plug	1	

Fig. 69 – Circuit Breaker and Relay Group

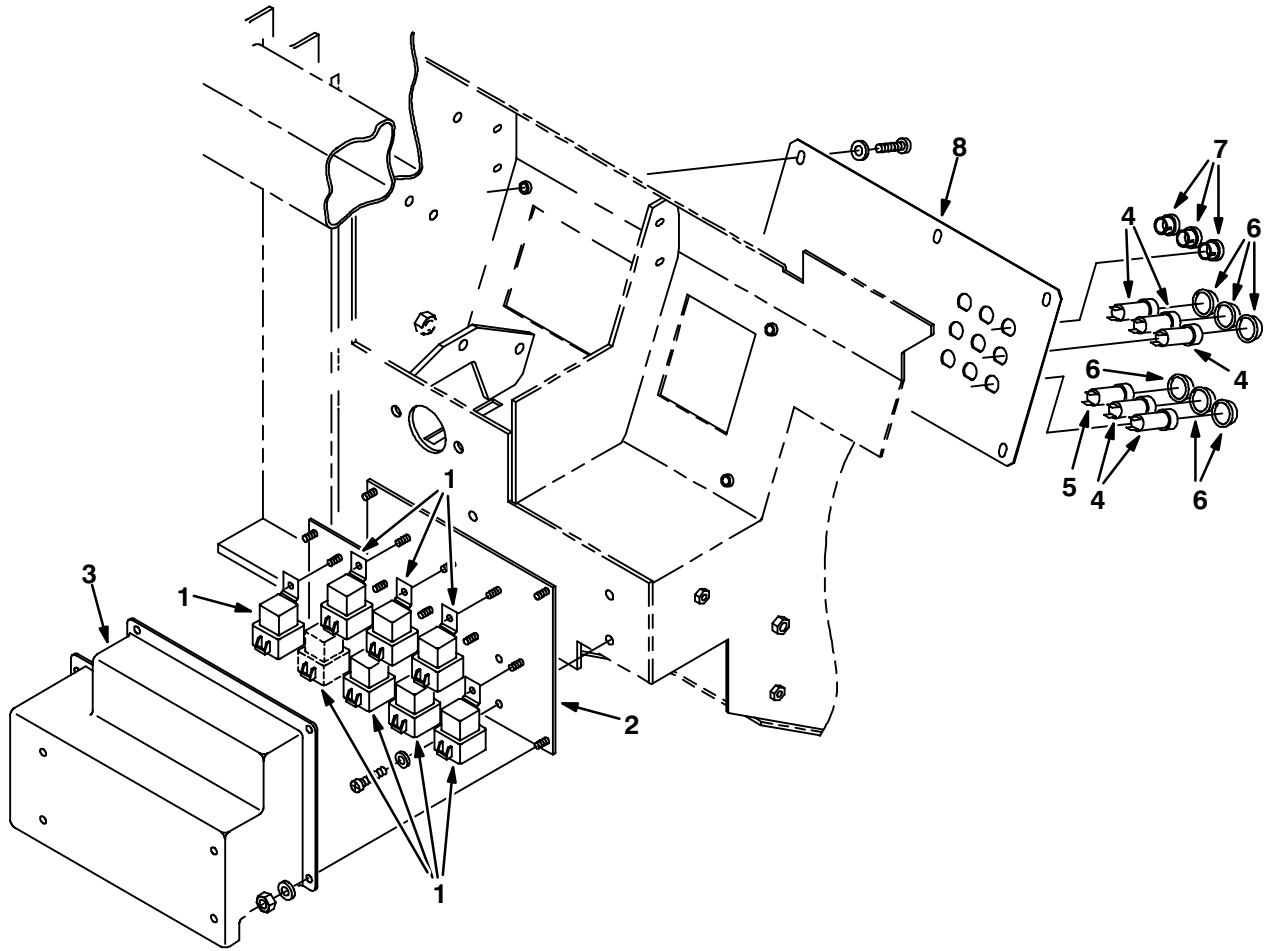

Fig. 69 – Circuit Breaker and Relay Group

Ref.	Tenant Part No.	Machine Serial Number	Description	Qty.
1	56186	(000000–) Relay, Shrouded, 12 Vdc	8
2	70398	(000000–) Plate, Mtg, Relay	1
3	70402	(000000–) Cover, Relay Panel	1
4	57803	(000000–) Breaker–Circuit, 15 Resetbl	5
5	87583	(000000–) Breaker–Circuit, 2.5 Resetbl	1
6	57751	(000000–) Boot–Circuit Breaker	6
7	57167	(000000–) Plugbtn .62H .03–.12 Blacknyl	3
8	70411	(000000–) Plate, Circuit Breaker	1

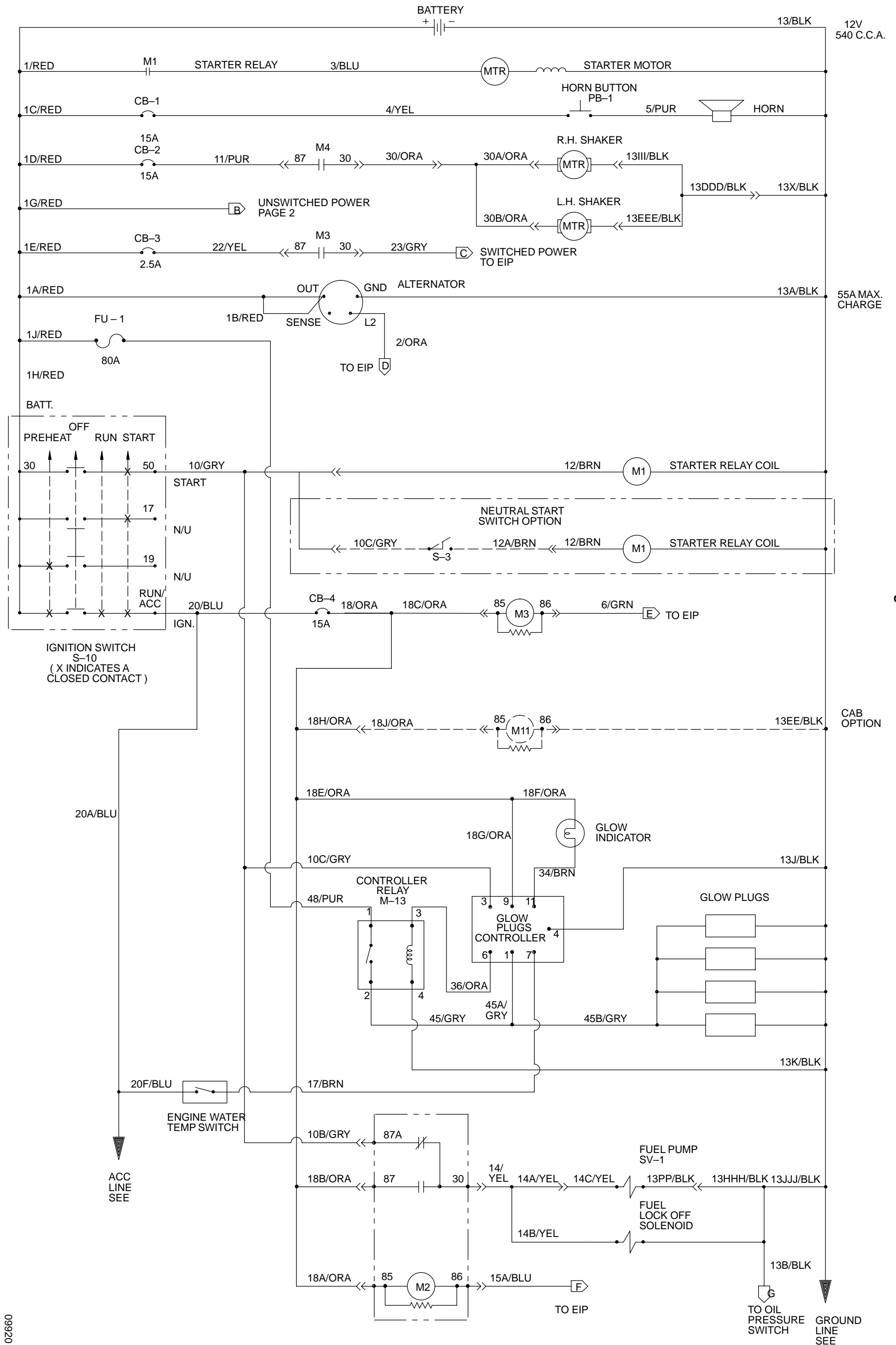

Fig. 70 - Electrical Schematic

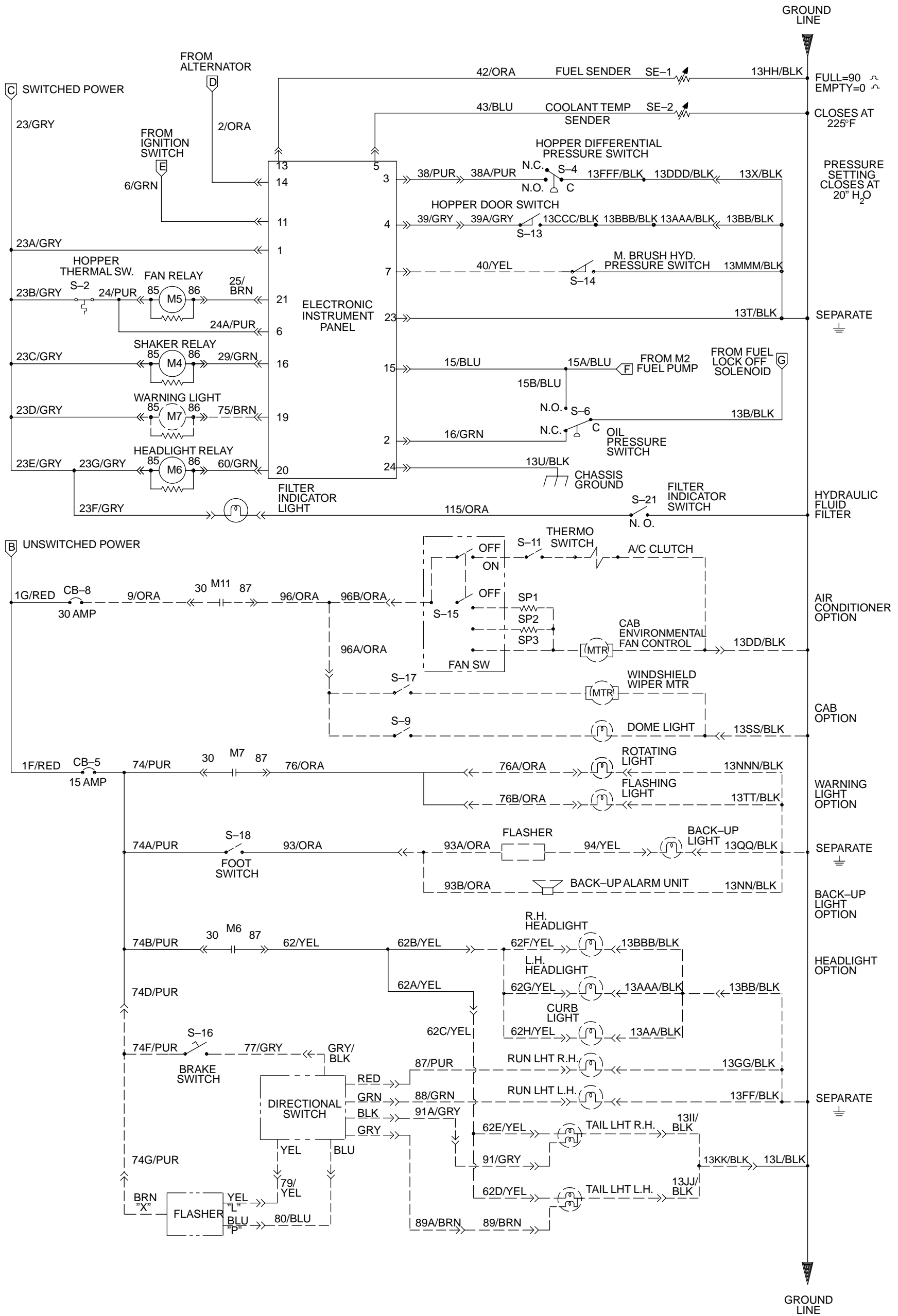

Fig. 70 - Electrical Schematic

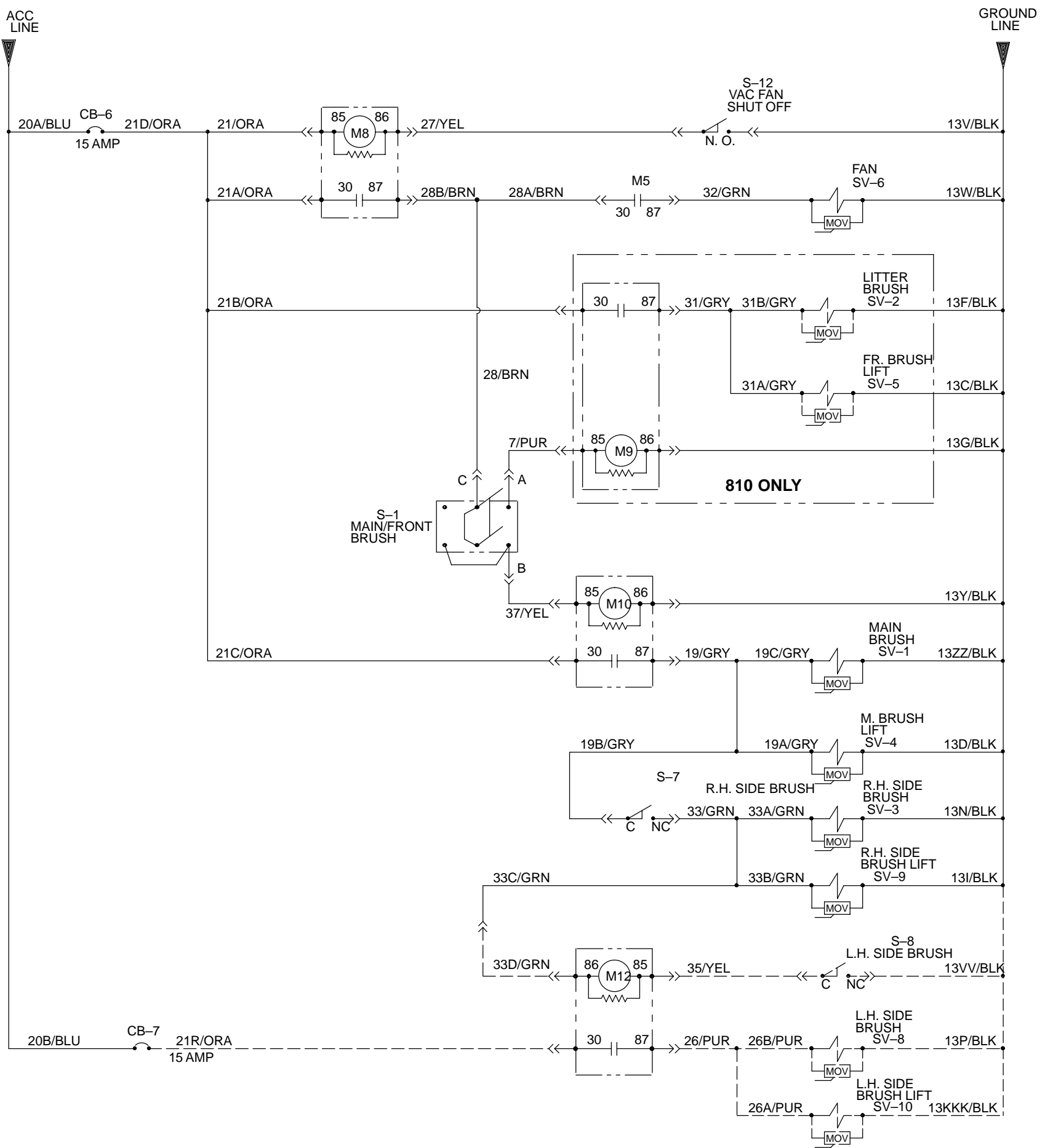

Fig. 70 - Electrical Schematic

LEGEND			
M	POWER RELAY	HM	HOURLMETER
MTR	MOTOR	SV	SOLENOID VALVE
CB	CIRCUIT BREAKER	S	SWITCH
PM	PERMANENT MAGNET	ACC	ACCESSORY
J	JACK-FEM. SOCKET	GND	GROUND CHASSIS
P	PLUG-MALE PIN	C	COMMON
PB	PUSHBUTTON	N.O.	NORMALLY OPEN
VM	VOLTMETER	N.C.	NORMALLY CLOSED
FU	FUSE	NOV	METAL OXIDE VARISTOR

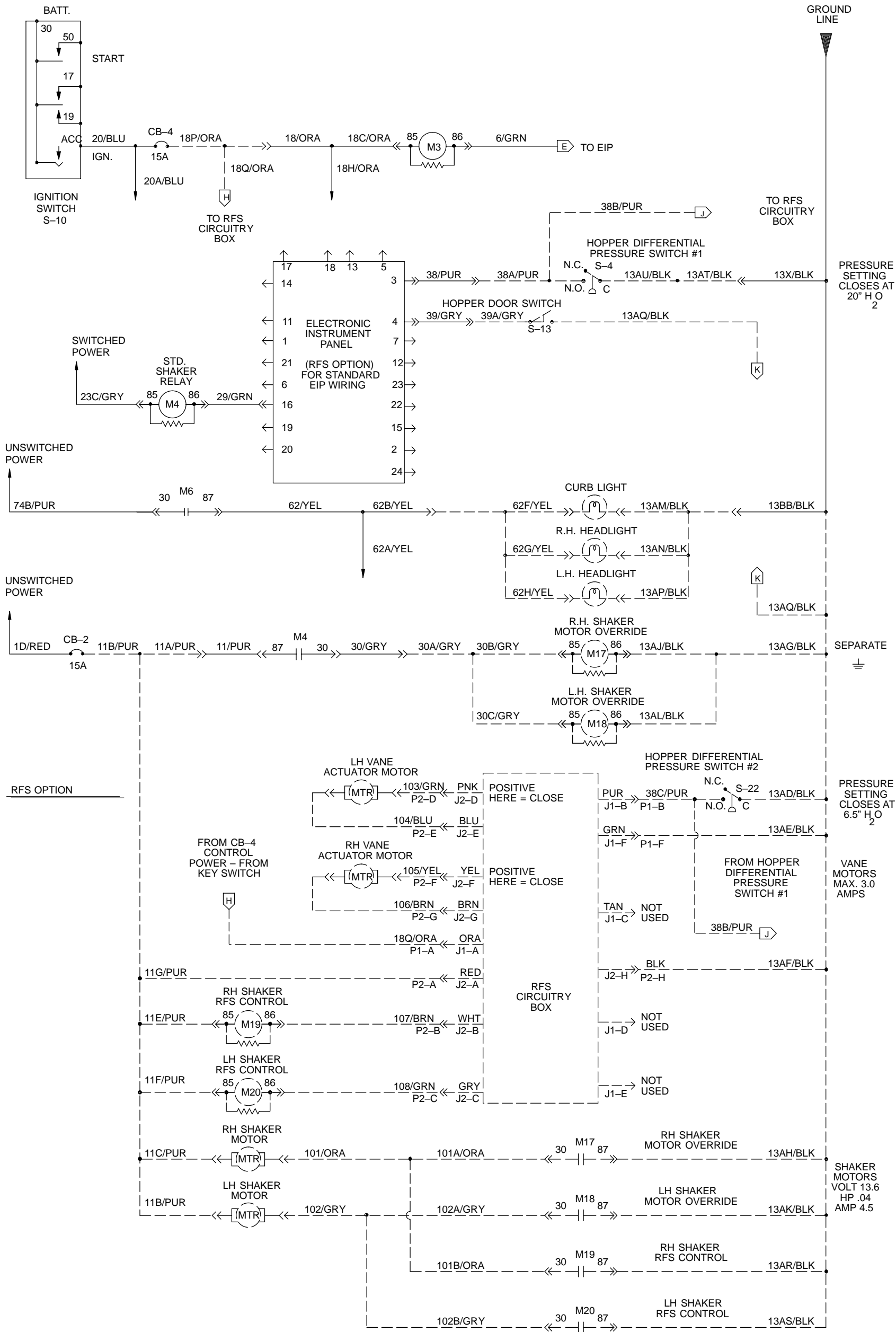
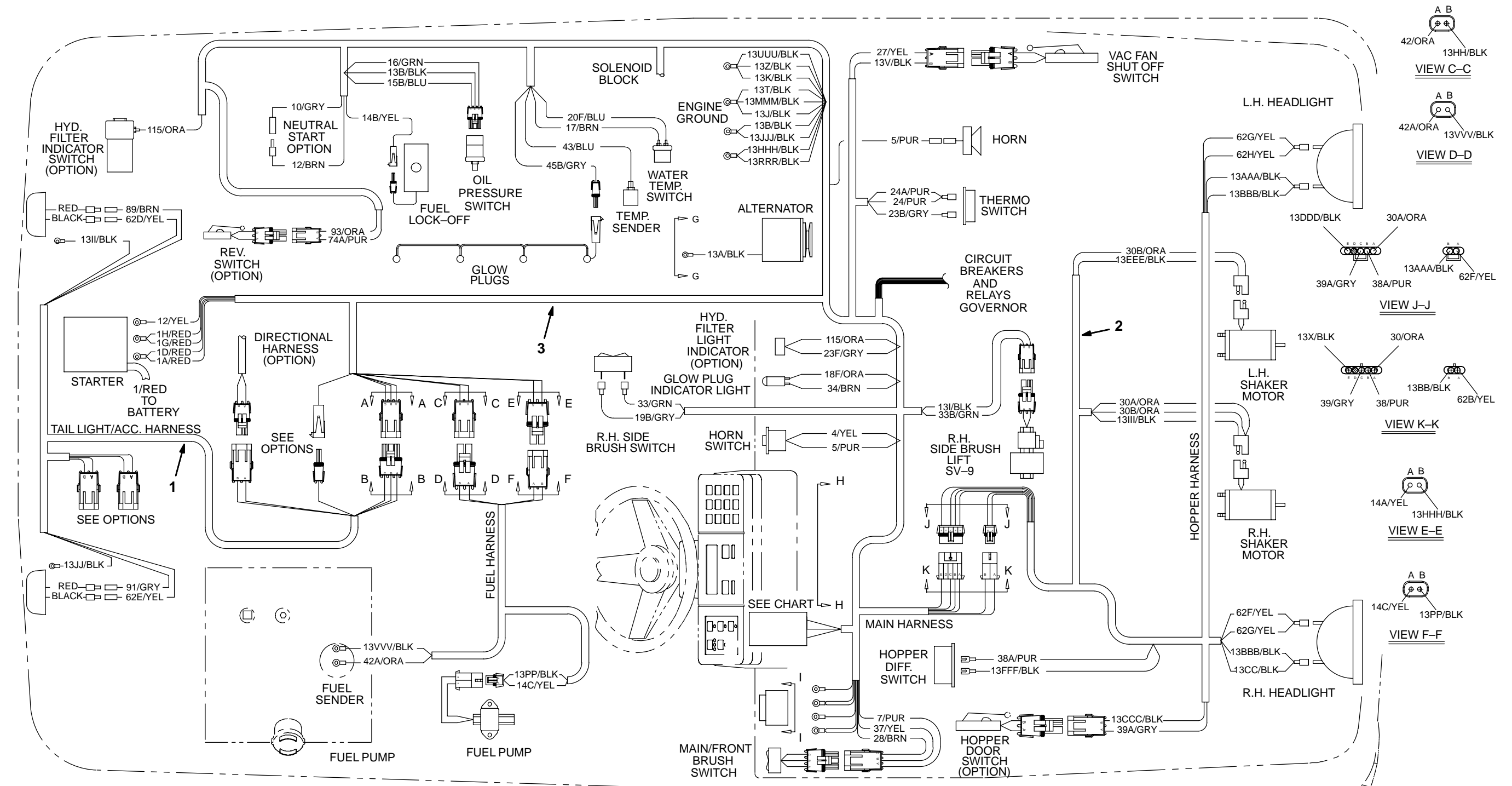

Fig. 70 - Electrical Schematic

Fig. 71 – Wire Harness Group



SOCKET NO.	WIRE NO.	COLOR	SOCKET NO.	WIRE NO.	COLOR	SOCKET NO.	WIRE NO.	COLOR	SOCKET NO.	WIRE NO.	COLOR
1	23A	GRY	7	40	YEL	13	42	ORA	19	75	BRN
2	16	GRN	8	PLUG	---	14	2	ORA	20	60	GRN
3	38	PUR	9	PLUG	---	15	15	BLU	21	25	BRN
4	39	GRY	10	PLUG	---	16	29	GRN	22	PLUG	---
5	43	BLU	11	6	GRN	17	PLUG	---	23	13T	BLK
6	24A	PUR	12	PLUG	---	18	PLUG	---	24	13U	BLK

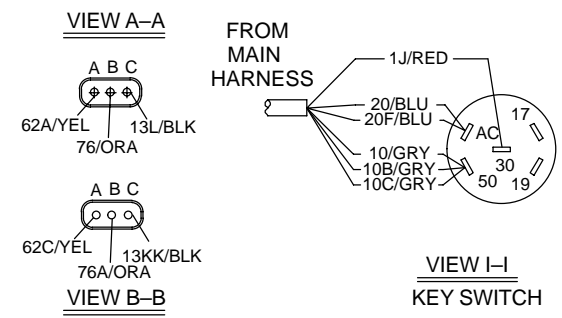
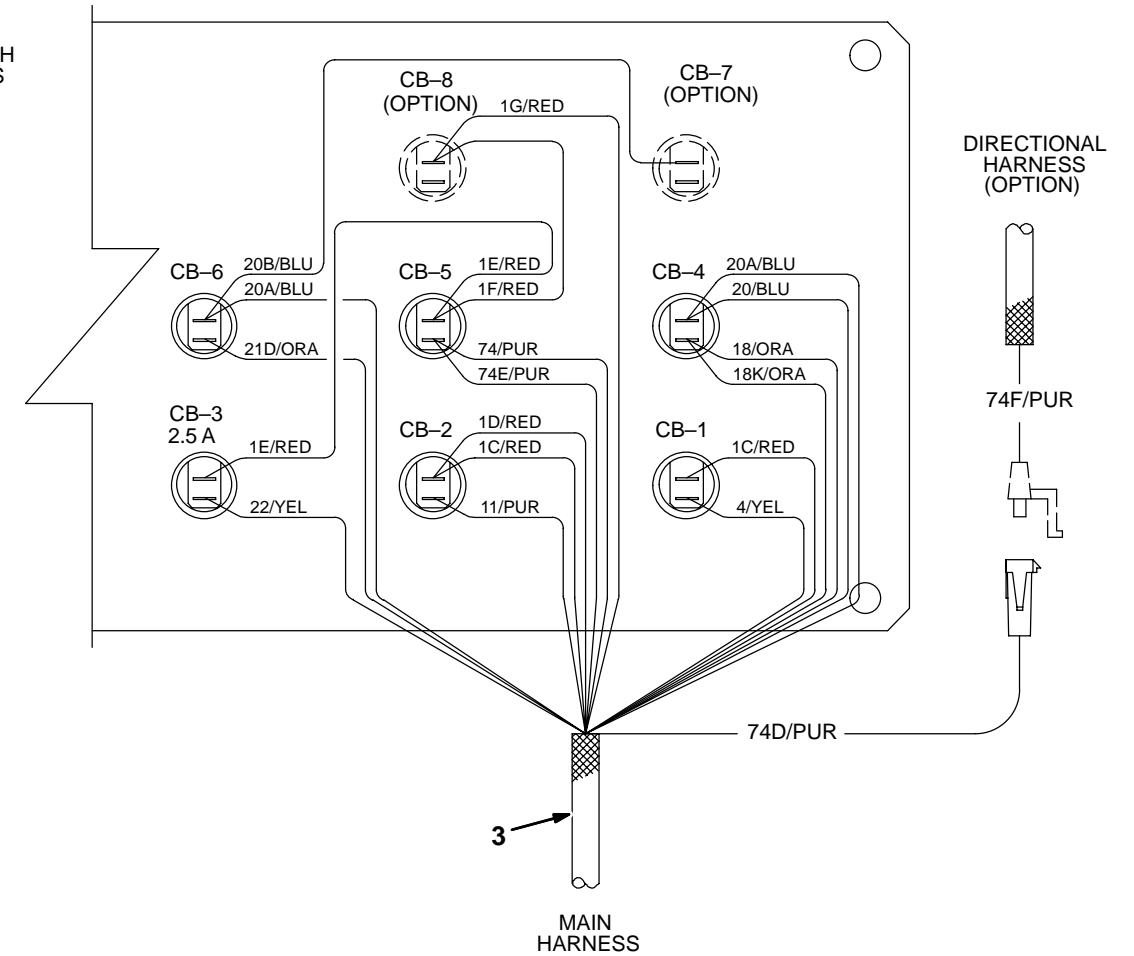
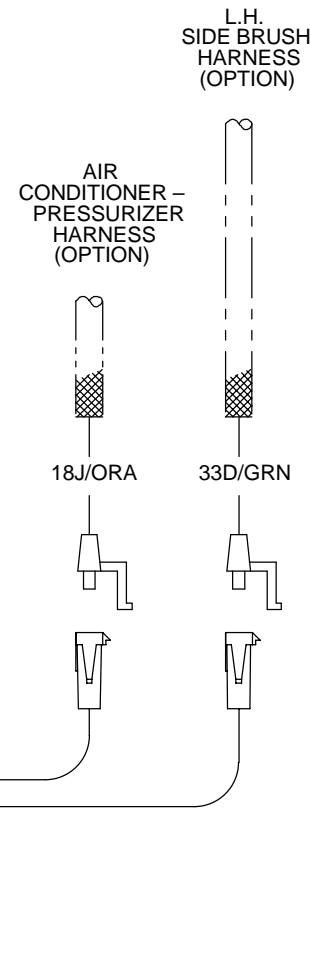
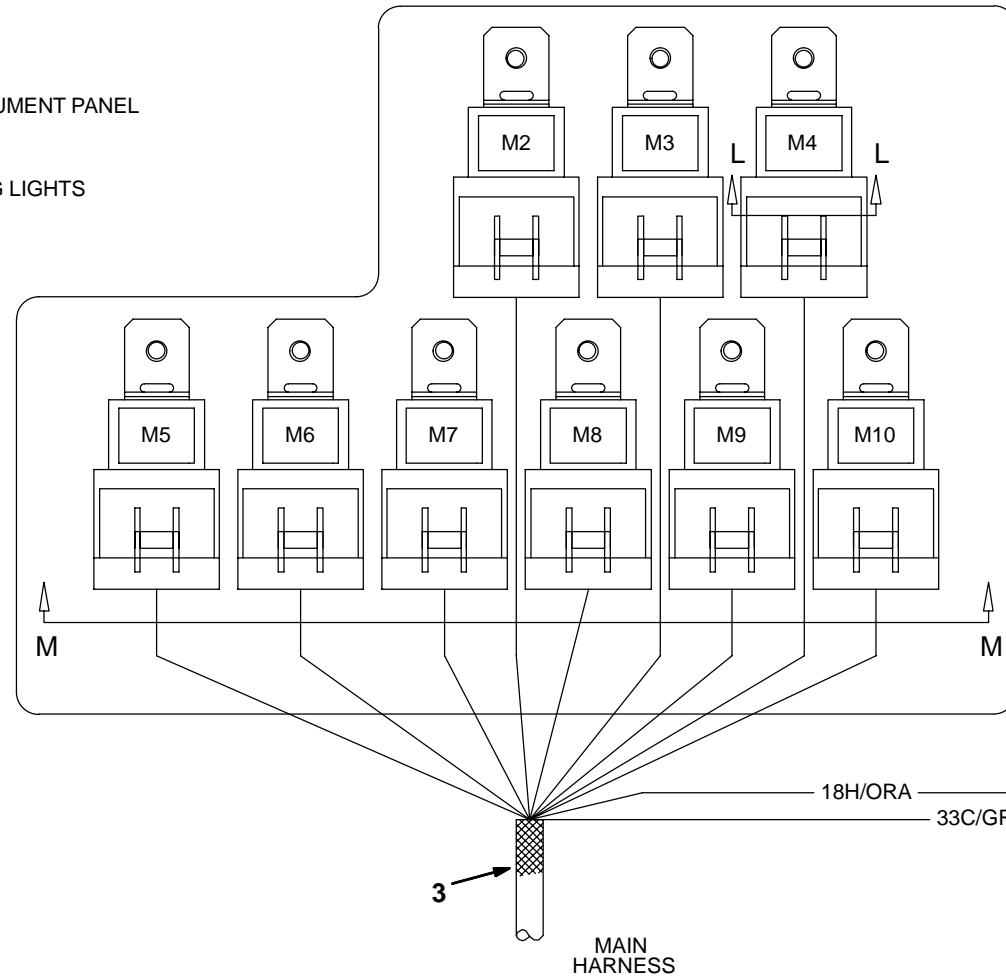

Fig. 71 – Wire Harness Group

RELAYS

- M2 FUEL PUMP
- M3 ELECTRONIC INSTRUMENT PANEL
- M4 SHAKER MOTOR
- M5 VAC FAN SOLENOID
- M6 HEADLIGHTS
- M7 ROTATING/FLASHING LIGHTS
- M8 HOPPER LIFT
- M9 FRONT BRUSH
- M10 MAIN BRUSH



CIRCUIT BREAKERS

- CB-1 HORN
- CB-2 SHAKER MOTOR
- CB-3 VAC FAN RELAY, SHAKER RELAY, WARNING LIGHT & HEADLIGHT
- CB-4 ELECTRONIC INSTRUMENT PANEL
- CB-5 ROTATING LIGHT & BACK-UP ALARM
- CB-6 HOPPER LIFT RELAY, FRONT/MAIN BRUSH
- CB-7 LEFT HAND SIDE BRUSH
- CB-8 CAB ACCESSORIES

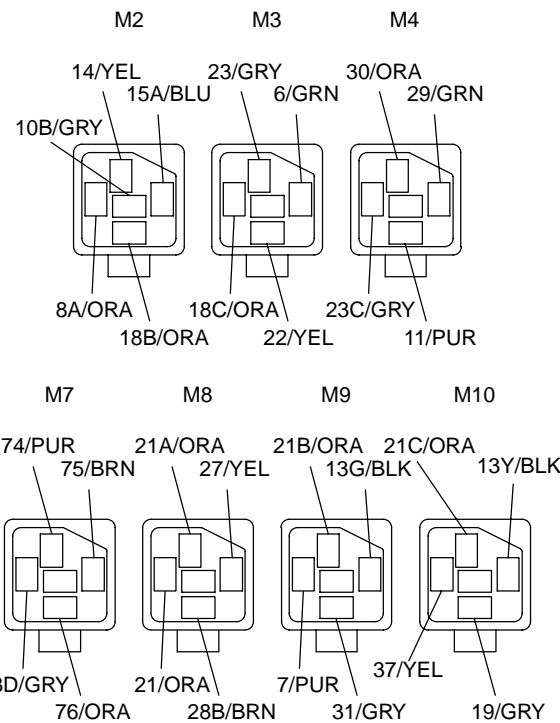

VIEW M-M

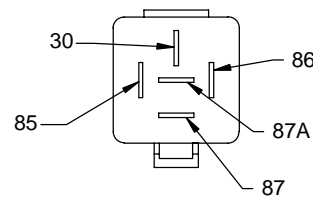

- 85 COIL+
- 86 COIL-
- 30 COMMON CONTACT
- 87 N.O. CONTACT
- 87A N.C. CONTACT

SECTION L-L

Fig. 71 - Wire Harness Group

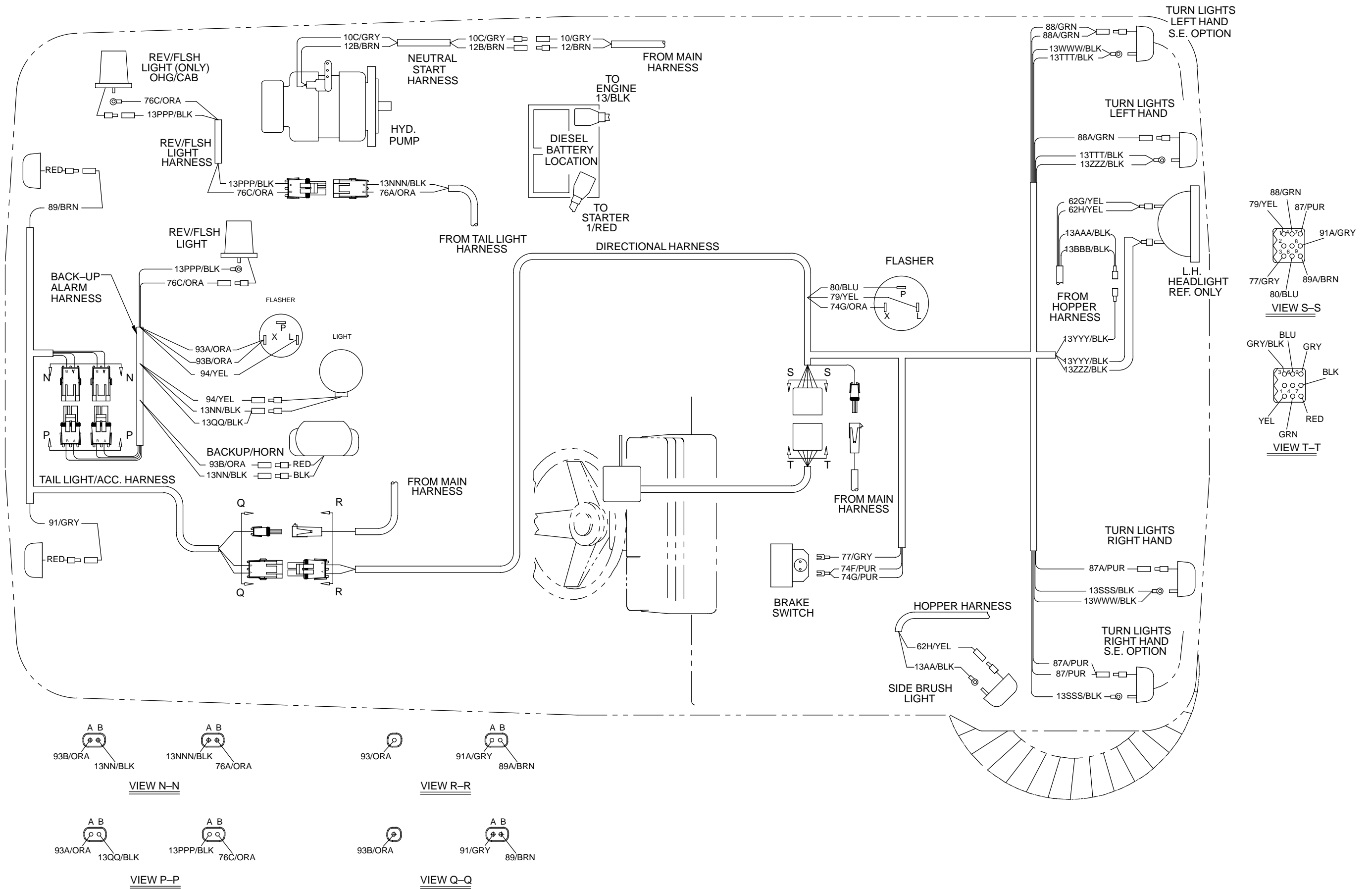

Fig. 71 – Wire Harness Group

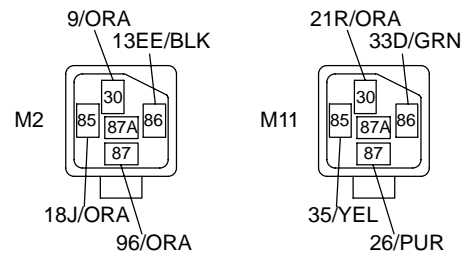
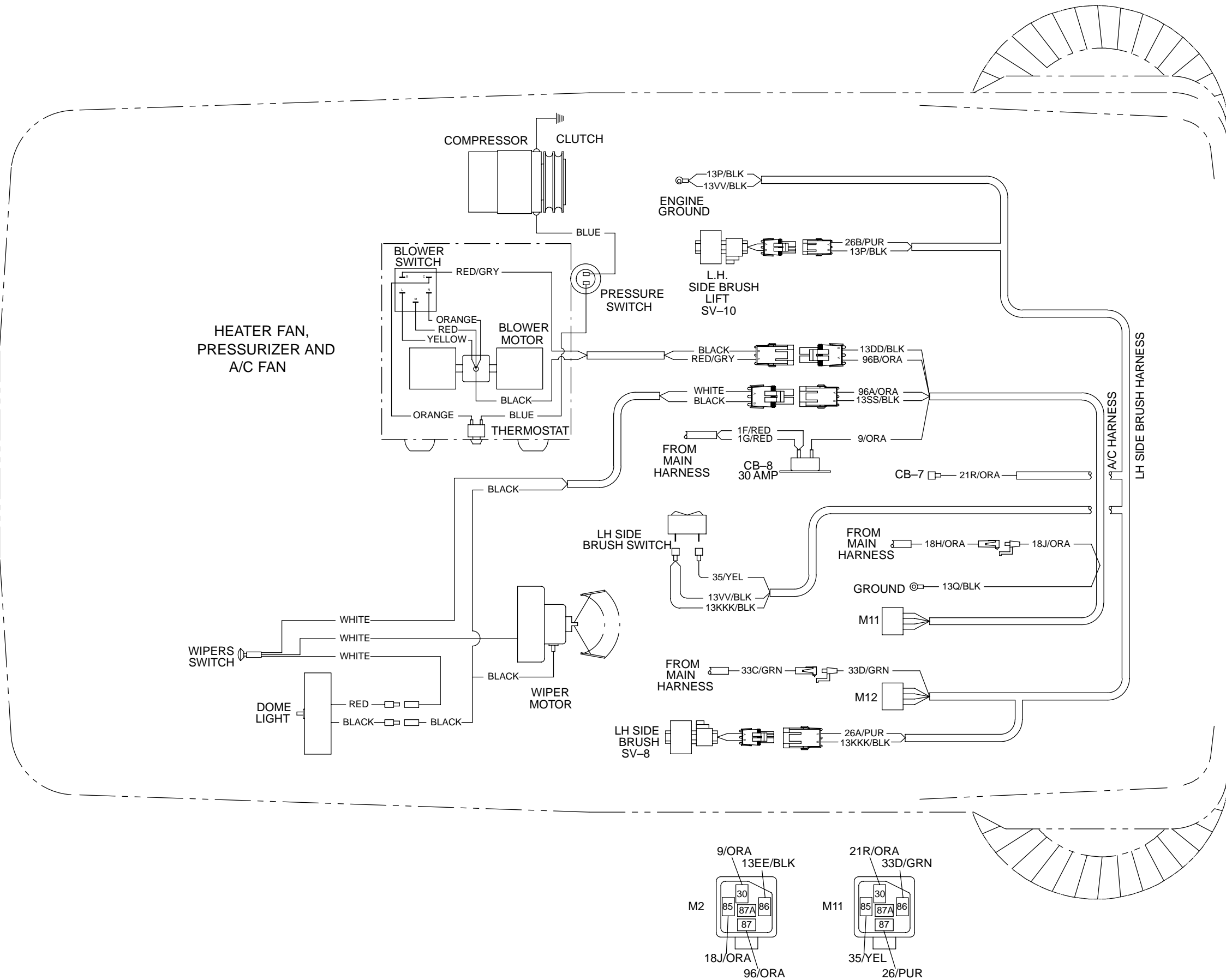

Fig. 71 – Wire Harness Group

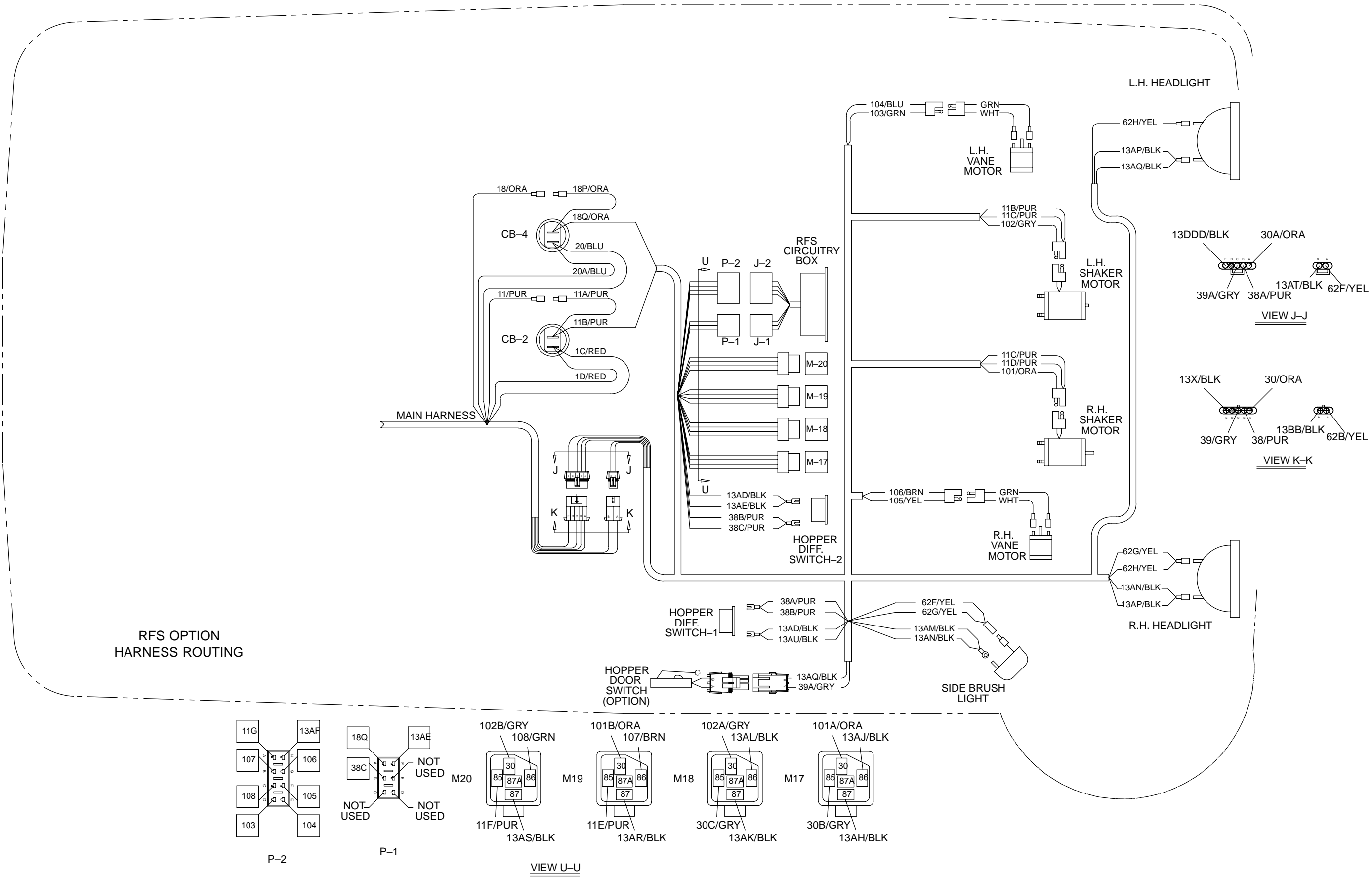
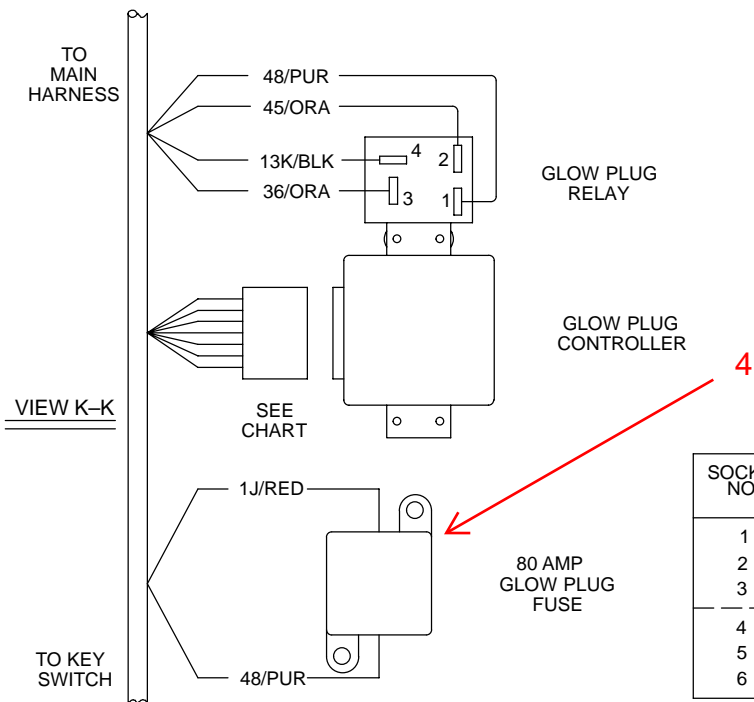
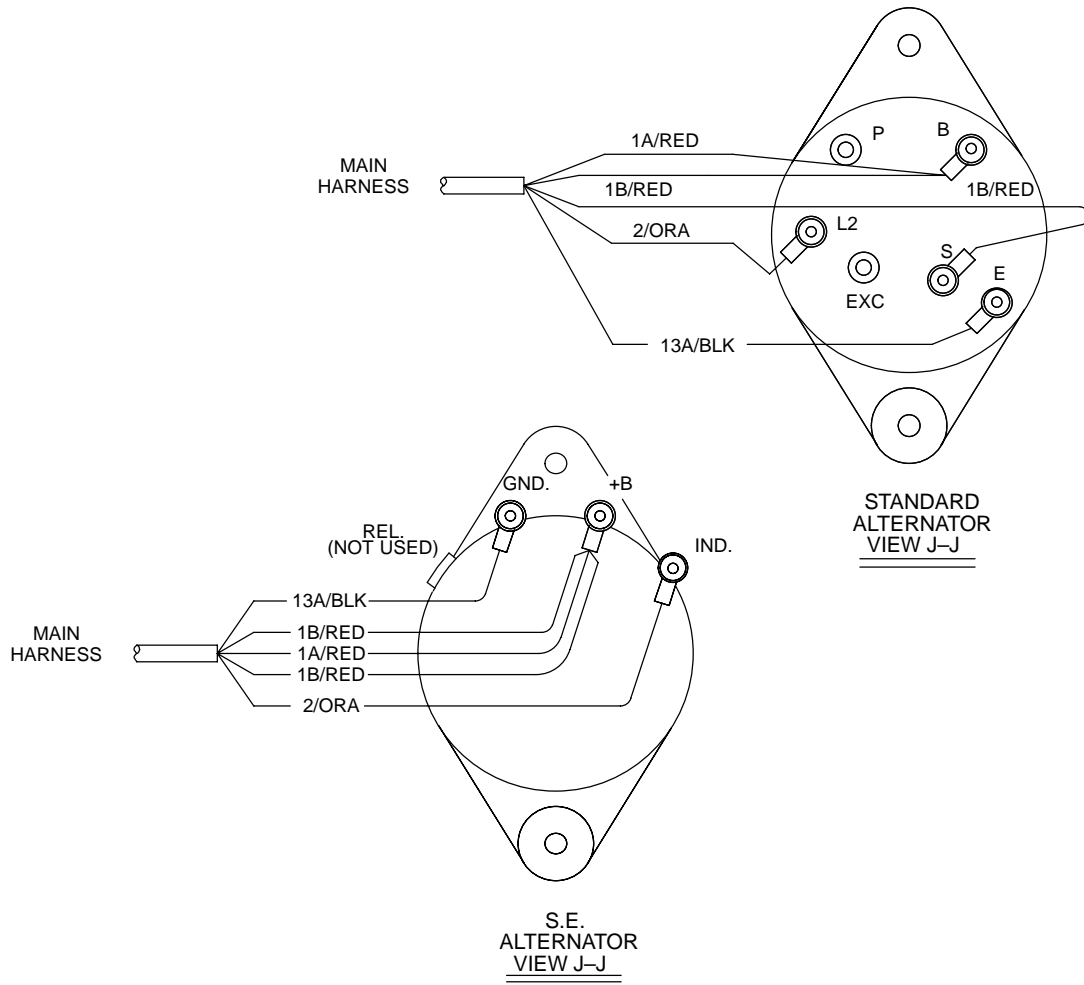
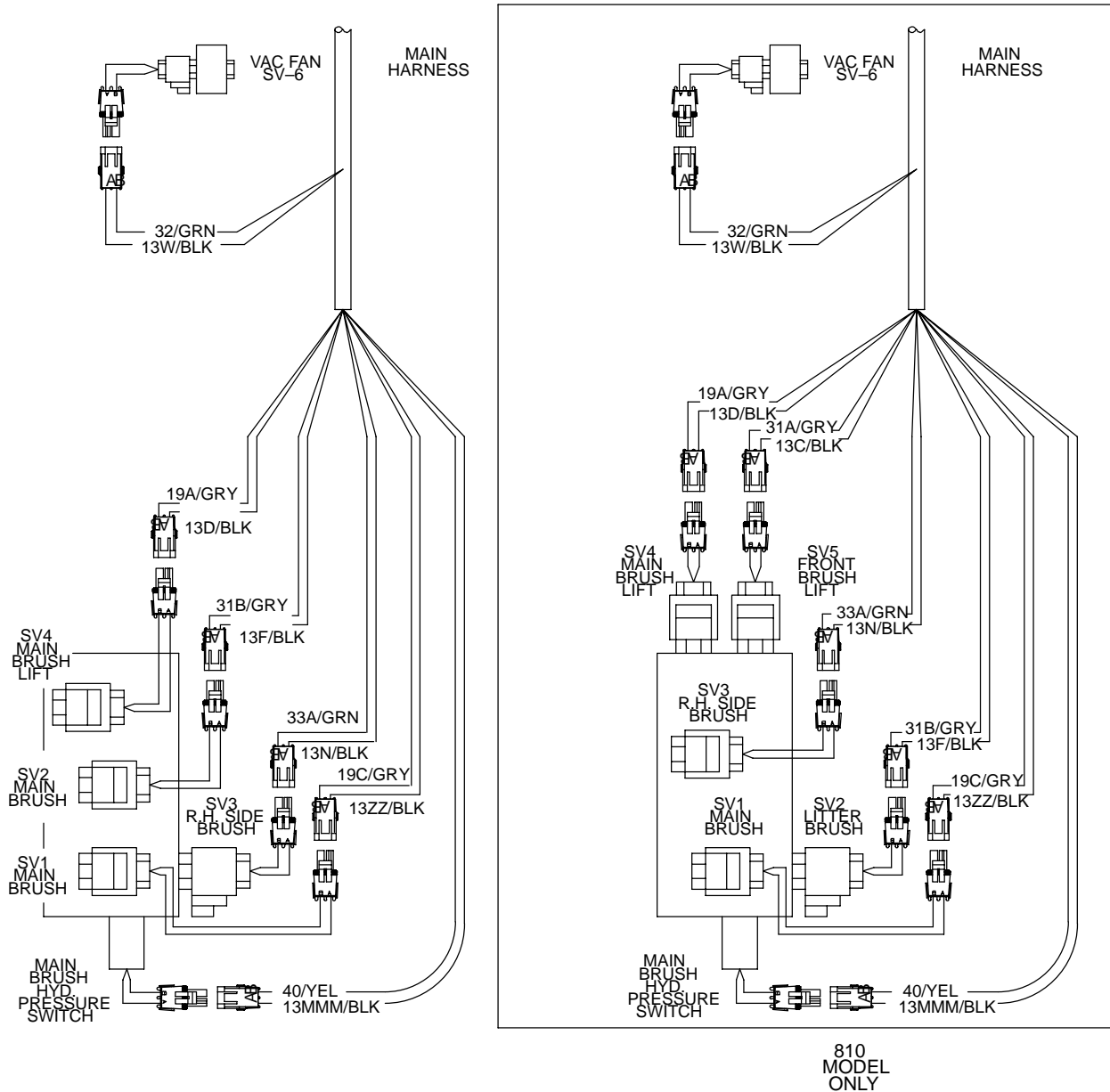

Fig. 71 – Wire Harness Group



SOCKET NO.	WIRE NO.	COLOR	SOCKET NO.	WIRE NO.	COLOR
1	45A	GRY	7	17	BRN
2	—	—	8	—	—
3	10C	GRY	9	18G	ORA
4	13J	BLK	10	—	—
5	—	—	11	34	BRN
6	36	ORA			

Fig. 71 – Wire Harnesses Group



810
MODEL
ONLY

08772/09921

Ref.	Tennant Part No.	Machine Serial Number	Description	Qty.
1	70400	(000000–)	Harness, Turn/Rotate/Tail Lights	1
2	63417	(000000–001699)	Harness, Hopper	1
2	83695	(001700–)	Harness, Hopper 800/810	1
3	77677	(000000–001699)	Harness, Main, Die, 800	1
3	83694	(001700–)	Harness, Main, Die, 800	1

4 34803

80 Amp Fuse

1

Fig. 72 – Label Group

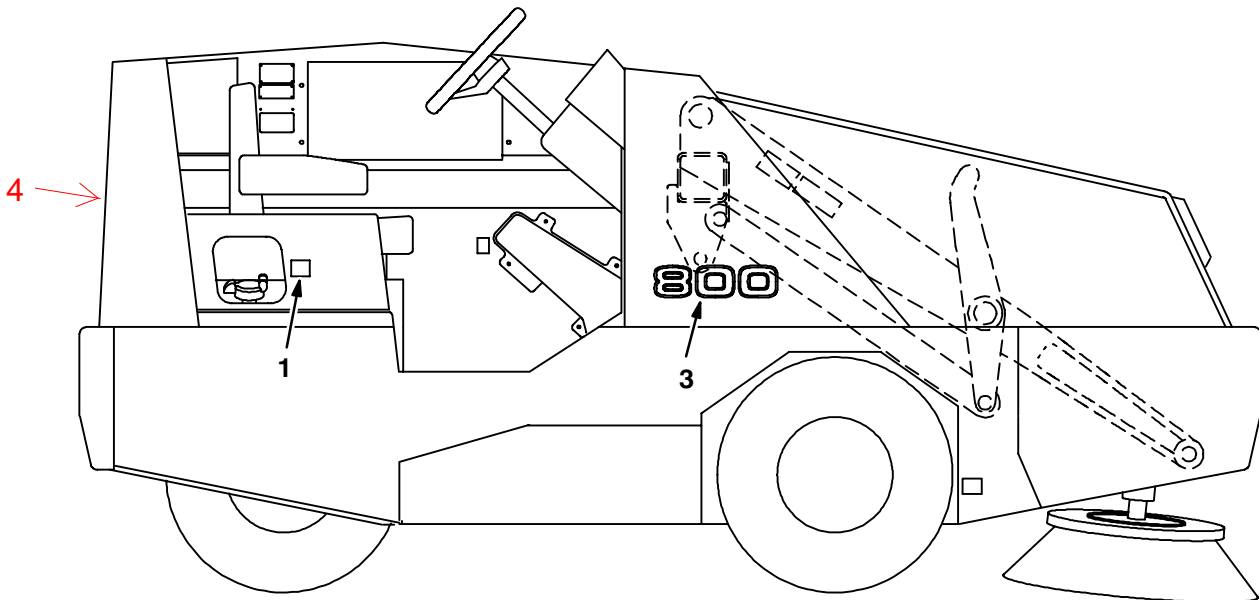
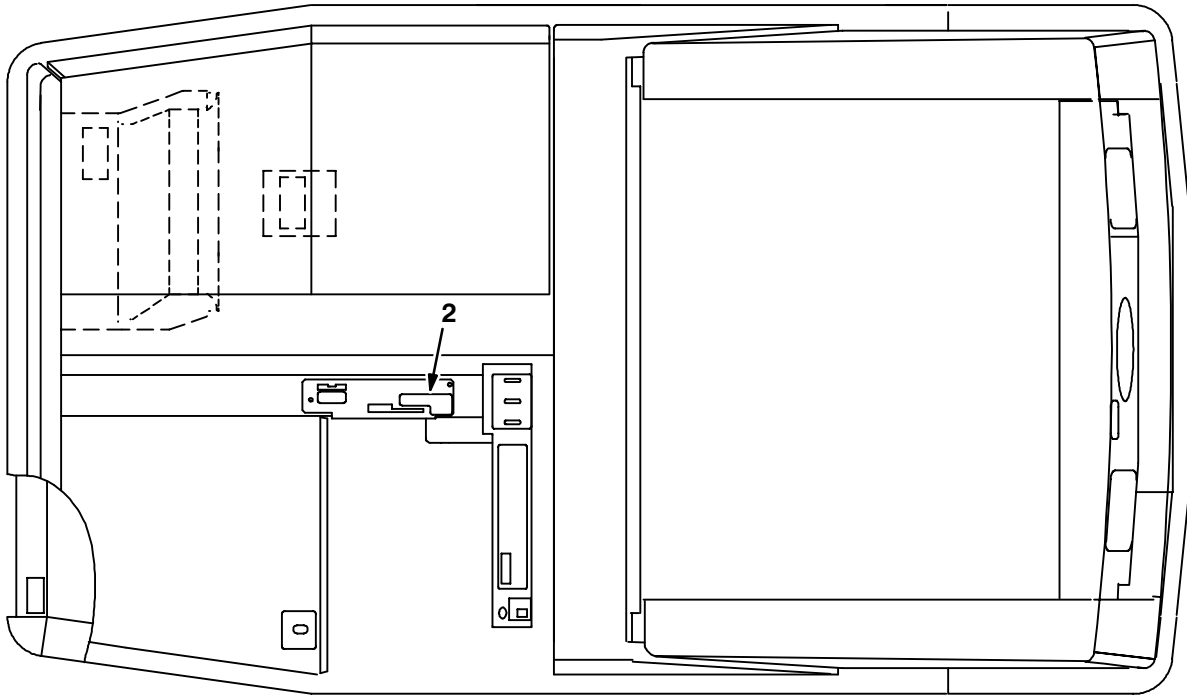

08566/08774

Ref.	Tenant Part No.	Machine Serial Number	Description	Qty.
1	59767	(000000–)	Label Set, Info & Hazard	1
2	70705	(000000–)	Label Set, Operational 800	1
3	70536	(000000–)	Label, Numerals 800	2
4	09905	(000000–)	Label, Logo, Tennant Oval	1

SECTION 3

CONTENTS

	PAGE
Fig. 1 – Flashing Light Kit, Overhead Guard	3-2
Fig. 2 – Revolving Light Kit, Overhead Guard	3-4
Fig. 3 – Flashing Light Kit, Cab	3-6
Fig. 4 – Revolving Light Kit, Cab	3-8
Fig. 5 – Flashing Light Kit, Low	3-10
Fig. 6 – Revolving Light Kit, Low	3-12
Fig. 7 – Back-Up Alarm Warning Kit	3-14
Fig. 8 – Back-Up Alarm Warning Kit, Blower Wand	3-16
Fig. 9 – Overhead Guard Kit	3-17
Fig. 10 – Blower Group	3-18
Fig. 11 – Blower Vac Fan Group	3-20
Fig. 12 – Blower Group	3-22
Fig. 13 – Blower Vac Fan Group	3-24
Fig. 14 – Hopper Floor Kit	3-26
Fig. 15 – Bumper Assembly, SE	3-27
Fig. 16 – Bumper Assembly, SE	3-28
Fig. 17 – Bumper Assembly, SE	3-29
Fig. 18 – Side Brush Lift Group, L.H.	3-30
Fig. 19 – Side Brush Lift Group, L.H.	3-32
Fig. 20 – Side Brush Group, L.H.	3-34
Fig. 21 – Side Brush Wire Harness Group, L.H.	3-36
Fig. 22 – Side Brush Wire Harness Group, L.H.	3-37
Fig. 23 – Side Brush Hydraulic Hose Group, L.H.	3-38
Fig. 24 – Side Brush Hydraulic Hose Group, L.H.	3-39
Fig. 25 – Side Brush Light Group	3-40
Fig. 26 – Cab Group	3-42
Fig. 27 – Cab Door Assembly	3-44
Fig. 28 – Cab Insulation Group	3-46
Fig. 29 – Mirror Kit	3-48
Fig. 30 – Air Cleaner Assembly, Air Conditioner	3-50
Fig. 31 – Air Conditioner Group	3-52
Fig. 32 – Heater/Pressurizer Assembly	3-54
Fig. 33 – Alternator Group, SE	3-56
Fig. 34 – Vacuum Wand Kit	3-58
Fig. 35 – Vacuum Wand Kit	3-60
Fig. 36 – Side Brush Dust Control Kit	3-62
Fig. 37 – Air Cleaner Assembly, Die SE	3-64
Fig. 38 – Protectoseal Fuel Tank Cap Group	3-66
Fig. 39 – Fire Extinguisher Kit	3-67
Fig. 40 – Solid Tire and Rim Assembly, Front	3-68
Fig. 41 – Solid Tire and Rim Assembly, Rear	3-69
Fig. 42 – Seat Belt Kit	3-70
Fig. 43 – Neutral Start Group	3-71
Fig. 44 – RFS Filter System Group	3-72
Fig. 45 – Documentation Group	3-74

Fig. 1 – Flashing Light Kit, Overhead Guard

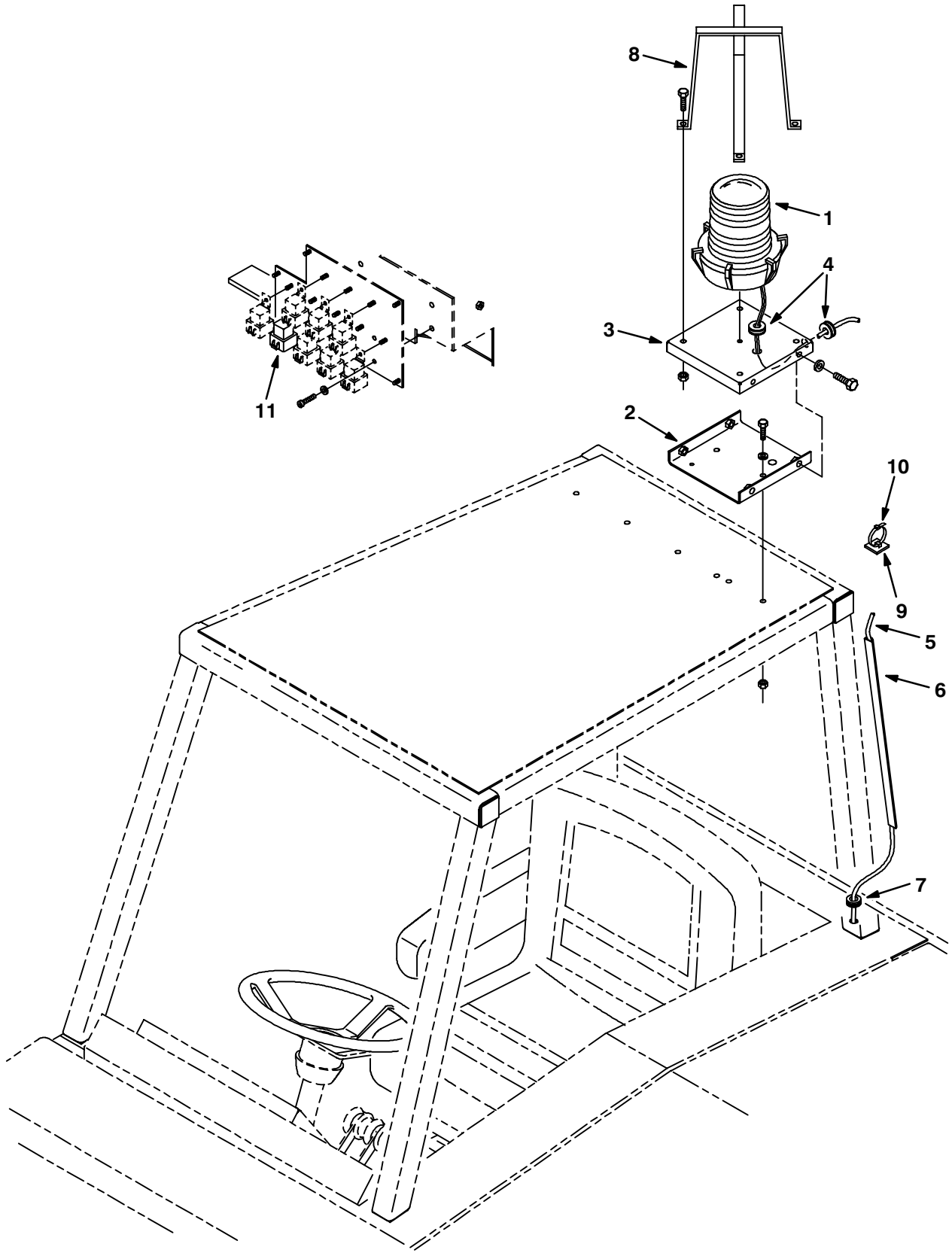

Fig. 1 – Flashing Light Kit, Overhead Guard

Ref.	Tennant Part No.	Machine Serial Number	Description	Qty.
∇	73755	(000000–)	Light Kit Flsh 800L Ohg	1
∇ 1	82063	(000000–)	Light, Flashing, Amber, 12V–Re	1
	58520	(000000–)	Lens,Flashing Lite Fr207 Amber	1
	45779	(000000–)	Bulb, 12V	1
2	73899	(000000–)	Bracket	1
3	73898	(000000–)	Panel	1
4	10632–20	(000000–)	Grommet,Rbr,0.38ld,For .06Matl	2
5	74000	(000000–)	Harness,Rev/Flsh Light,Cab,Ohg	1
6	86331	(000000–)	Duct, Vinyl .40X .75X26.0 .25D	1
7	10632–2	(000000–)	Grommet,Rbr,0.63ld,For .13Matl	1
8	45272	(000000–)	Guard Wldt, Lights, Revl & Flsh	1
9	55248	(000000–)	Cable Tie Mount	3
10	49266	(000000–)	Tie, Cable	3
11	56186	(000000–)	Relay, Shrouded, 12V	1
	58518	(000000–)	Lens,Flashing Lite Fr207 Red	1
	58519	(000000–)	Lens,Flashing Lite Fr207 Blue	1

Fig. 2 – Revolving Light Kit, Overhead Guard

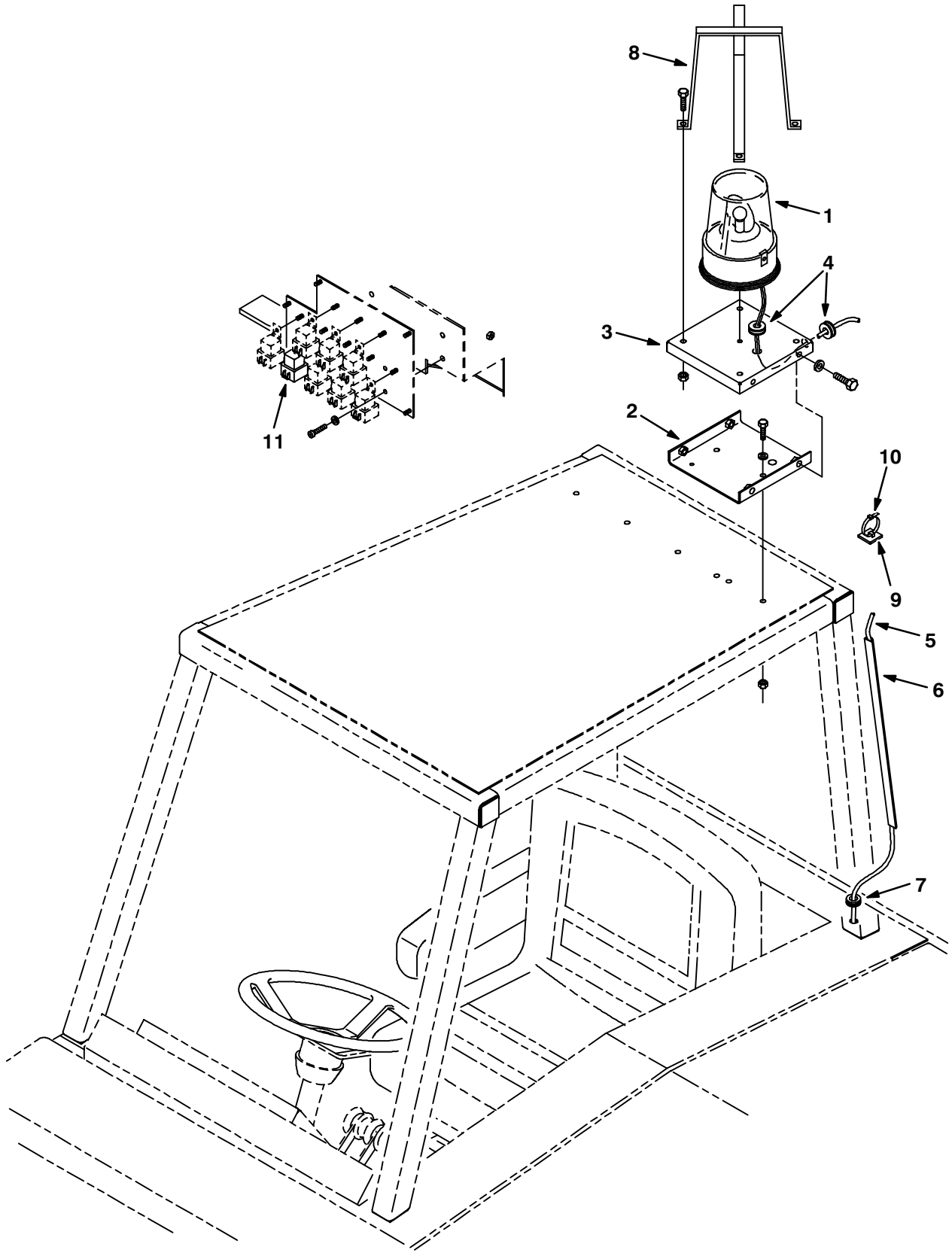

Fig. 2 – Revolving Light Kit, Overhead Guard

Ref.	Tennant Part No.	Machine Serial Number	Description	Qty.
∇	73757	(000000–)	Light Kit Revl 800L Ohg	1
∇ 1	82200	(000000–)	Light,Rev.Amber 12V–Reworked	1
	44681–1	(000000–)	Lens,Rev.Light,Amber	1
	45779	(000000–)	Bulb, 12V	1
2	73899	(000000–)	Bracket	1
3	73898	(000000–)	Panel	1
4	10632–20	(000000–)	Grommet,Rbr,0.38ld,For .06Matl	2
5	74000	(000000–)	Harness,Rev/Flsh Light,Cab,Ohg	1
6	86331	(000000–)	Duct, Vinyl .40X .75X26.0 .25D	1
7	10632–2	(000000–)	Grommet,Rbr,0.63ld,For .13Matl	1
8	45272	(000000–)	Guard Wldt, Lights, Revl & Flsh	1
9	55248	(000000–)	Cable Tie Mount	3
10	49266	(000000–)	Tie, Cable	3
11	56186	(000000–)	Relay, Shrouded, 12V	1
	44681	(000000–)	Lens,Rev.Light,Red	1
	44681–2	(000000–)	Lens,Rev.Light,Blue	1

Fig. 3 – Flashing Light Kit, Cab

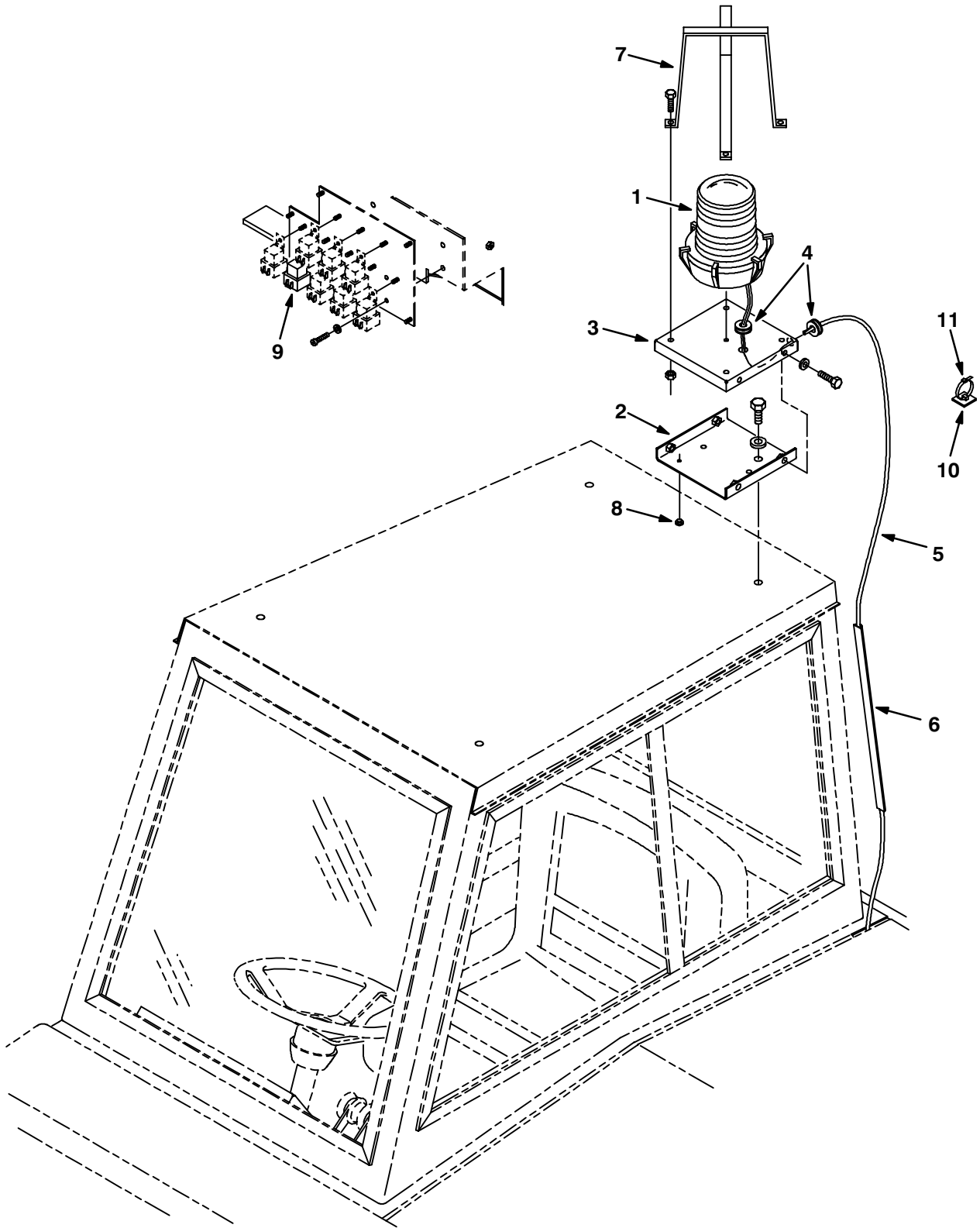

Fig. 3 – Flashing Light Kit, Cab

Ref.	Tenant Part No.	Machine Serial Number	Description	Qty.
∇	73751	(000000–)	Light Kit Flsh 800L Cab	1
∇ 1	82063	(000000–)	Light, Flashing, Amber, 12V–Re	1
	58520	(000000–)	Lens,Flashing Lite Fr207 Amber	1
	45779	(000000–)	Bulb, 12V	1
2	73899	(000000–)	Bracket	1
3	73898	(000000–)	Panel	1
4	10632–20	(000000–)	Grommet,Rbr,0.38ld,For .06Matl	2
5	74000	(000000–)	Harness,Rev/Flsh Light,Cab,Ohg	1
6	86331	(000000–)	Duct, Vinyl .40X .75X26.0 .25D	1
7	45272	(000000–)	Guard Wldt, Lights, Revl & Flsh	1
8	29233	(000000–)	Bumper, Rubber	1
9	56186	(000000–)	Relay, Shrouded, 12V	1
10	55248	(000000–)	Cable Tie Mount	3
11	49266	(000000–)	Tie, Cable	3
	58518	(000000–)	Lens,Flashing Lite Fr207 Red	1
	58519	(000000–)	Lens,Flashing Lite Fr207 Blue	1

Fig. 4 – Revolving Light Kit, Cab

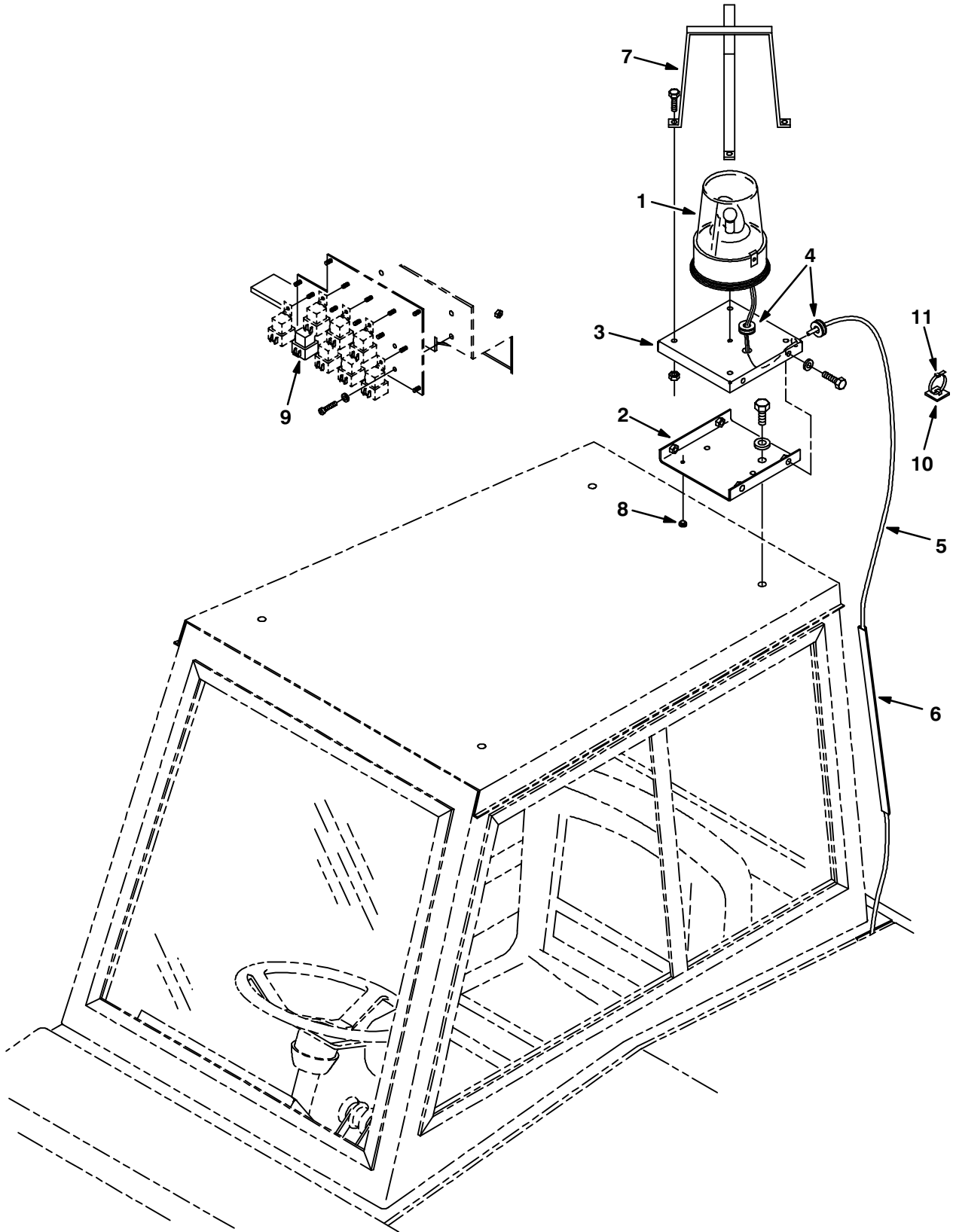

Fig. 4 – Revolving Light Kit, Cab

Ref.	Tennant Part No.	Machine Serial Number	Description	Qty.
∇	73753	(000000–)	Light Kit Revl 800L Cab	1
∇ 1	82200	(000000–)	Light,Rev.Amber 12V–Reworked	1
	44681–1	(000000–)	Lens,Rev.Light,Amber	1
	45779	(000000–)	Bulb, 12V	1
2	73899	(000000–)	Bracket	1
3	73898	(000000–)	Panel	1
4	10632–20	(000000–)	Grommet,Rbr,0.38ld,For .06Matl	2
5	74000	(000000–)	Harness,Rev/Flsh Light,Cab,Ohg	1
6	86331	(000000–)	Duct, Vinyl .40X .75X26.0 .25D	1
7	45272	(000000–)	Guard Wldt, Lights, Revl & Flsh	1
8	29233	(000000–)	Bumper, Rubber	1
9	56186	(000000–)	Relay, Shrouded, 12V	1
10	55248	(000000–)	Cable Tie Mount	3
11	49266	(000000–)	Tie, Cable	3
	44681	(000000–)	Lens,Rev.Light,Red	1
	44681–2	(000000–)	Lens,Rev.Light,Blue	1

Fig. 5 – Flashing Light Kit, Low

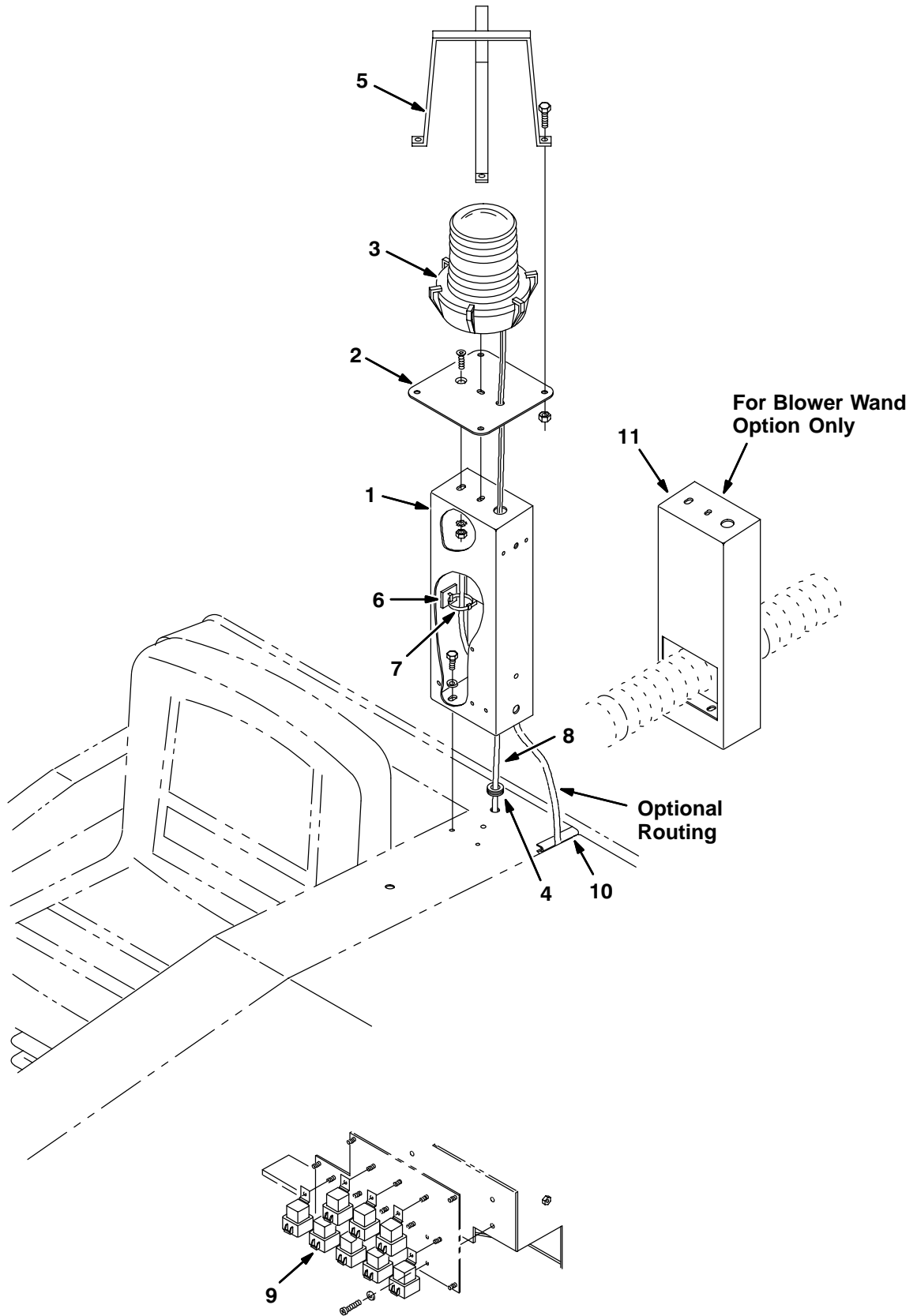

Fig. 5 – Flashing Light Kit, Low

Ref.	Tennant Part No.	Machine Serial Number	Description	Qty.
∇	73759	(000000–)	Light Kit Flashing	1
1	76404	(000000–)	Channel,	1
2	75573	(000000–)	Plate	1
∇	3 82063	(000000–)	Light, Flashing, Amber, 12V–Re	1
	58520	(000000–)	Lens,Flashing Lite Fr207 Amber	1
	45779	(000000–)	Bulb, 12V .2A 32Cp #1156	1
4	10632–11	(000000–)	Grommet,Rbr,0.38ld,For .19Matl	1
5	45272	(000000–)	Guard Wldt, Lights, Revl&Fish	1
6	55248	(000000–)	Cabletie Mount, Adhesive	1
7	49266	(000000–)	Tie, Cable 1.75D Max 7.50Lg	1
8	74000	(000000–)	Harness, Rev/Flash Light,Cab O	1
9	56186	(000000–)	Relay, Shrouded, 12 Vdc	1
10	62595–18	(000000–)	Molding, Trim 11–14Ga 3.00	1
11	79513	(000000–)	Channel Wldt, Blower Wand	1
	58518	(000000–)	Lens,Flashing Lite Fr207 Red	1
	58519	(000000–)	Lens,Flashing Lite Fr207 Blue	1

Fig. 6 – Revolving Light Kit, Low

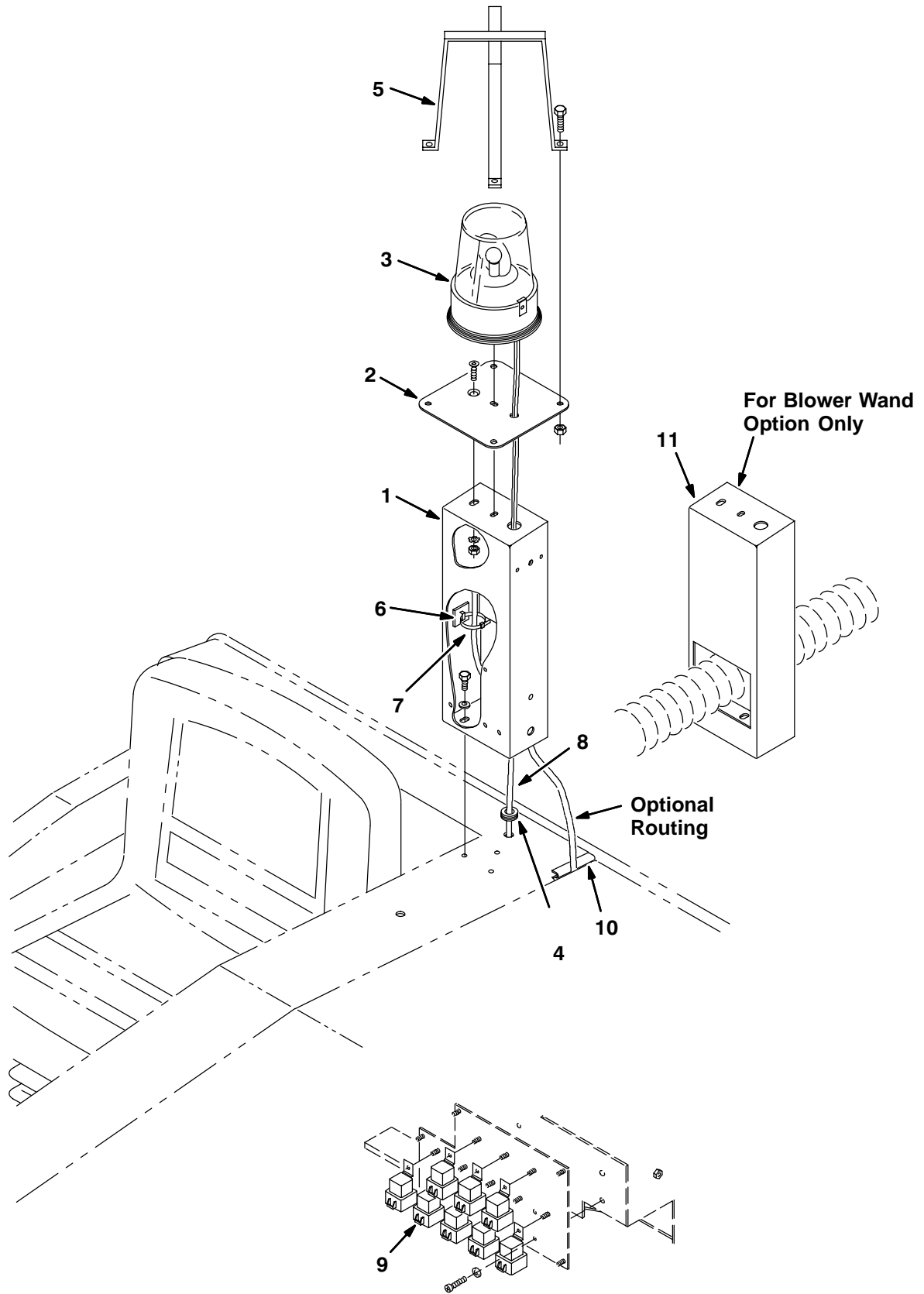

Fig. 6 – Revolving Light Kit, Low

Ref.	Tennant Part No.	Machine Serial Number	Description	Qty.
∇	73761	(000000–) Light Kit Revl 800 Low	1
1	76404	(000000–) Channel,	1
2	75573	(000000–) Plate	1
∇	82200	(000000–) Light,Rev.Amber 12V	1
3	44681–1	(000000–) Lens,Rev.Light,Amber	1
	45779	(000000–) Bulb, 12V .2A 32Cp #1156	1
4	10632–11	(000000–) Grommet,Rbr,0.38ld,For .19Matl	1
5	45272	(000000–) Guard Wldt, Lights, Revl&Fish	1
6	55248	(000000–) Cabletie Mount, Adhesive	1
7	49266	(000000–) Tie, Cable 1.75D Max 7.50Lg	1
8	74000	(000000–) Harness, Rev/Flash Light,Cab O	1
9	56186	(000000–) Relay, Shrouded, 12 Vdc	1
10	62595–18	(000000–) Molding, Trim 11–14Ga 3.00	1
11	79513	(000000–) Channel Wldt, Blower Wand	1
	44681	(000000–) Lens,Rev.Light,Red	1
	44681–2	(000000–) Lens,Rev.Light,Blue	1

Fig. 7 – Back-Up Alarm Warning Kit

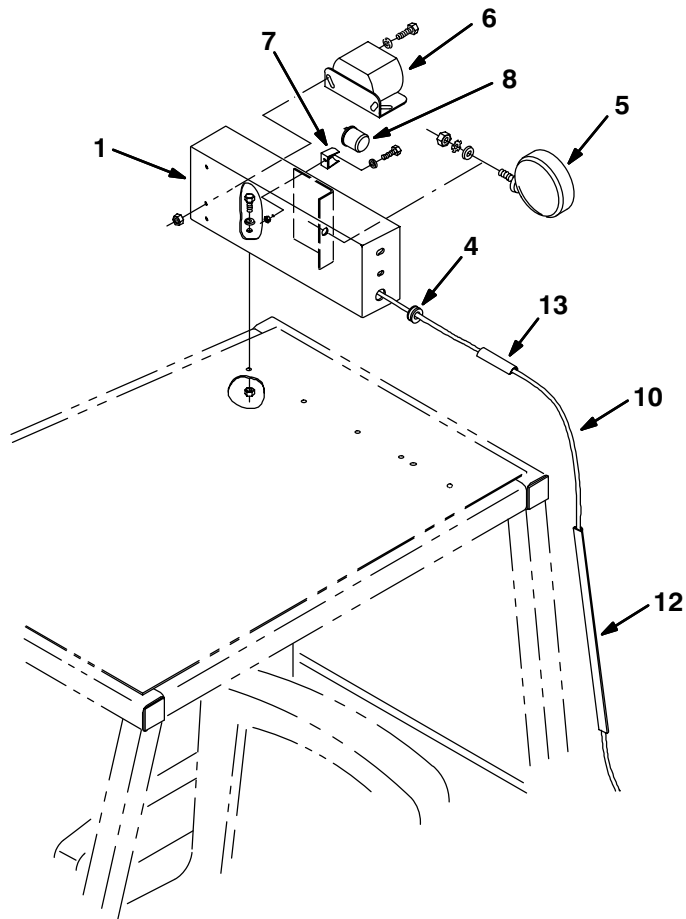
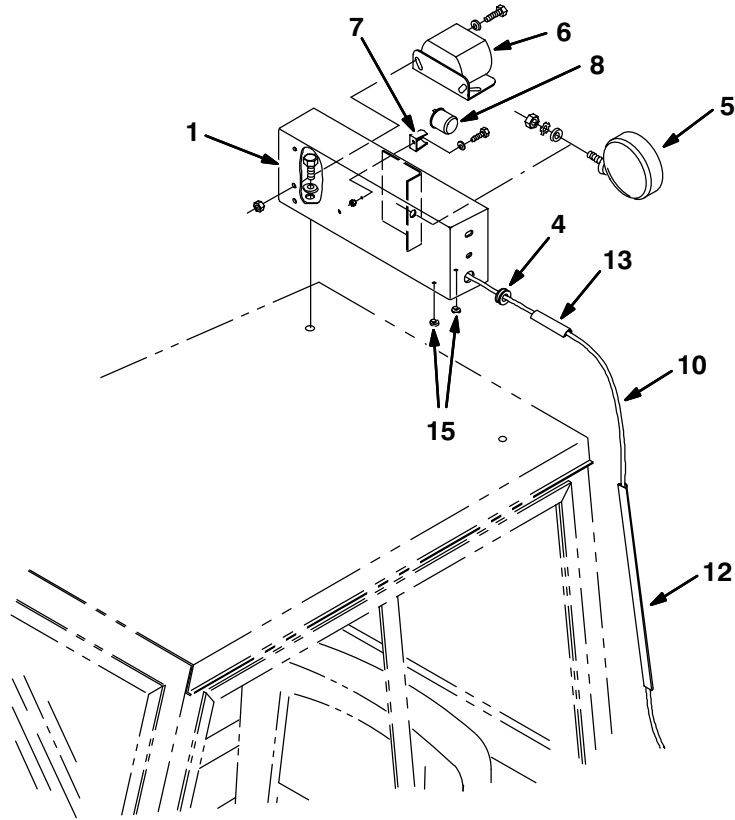
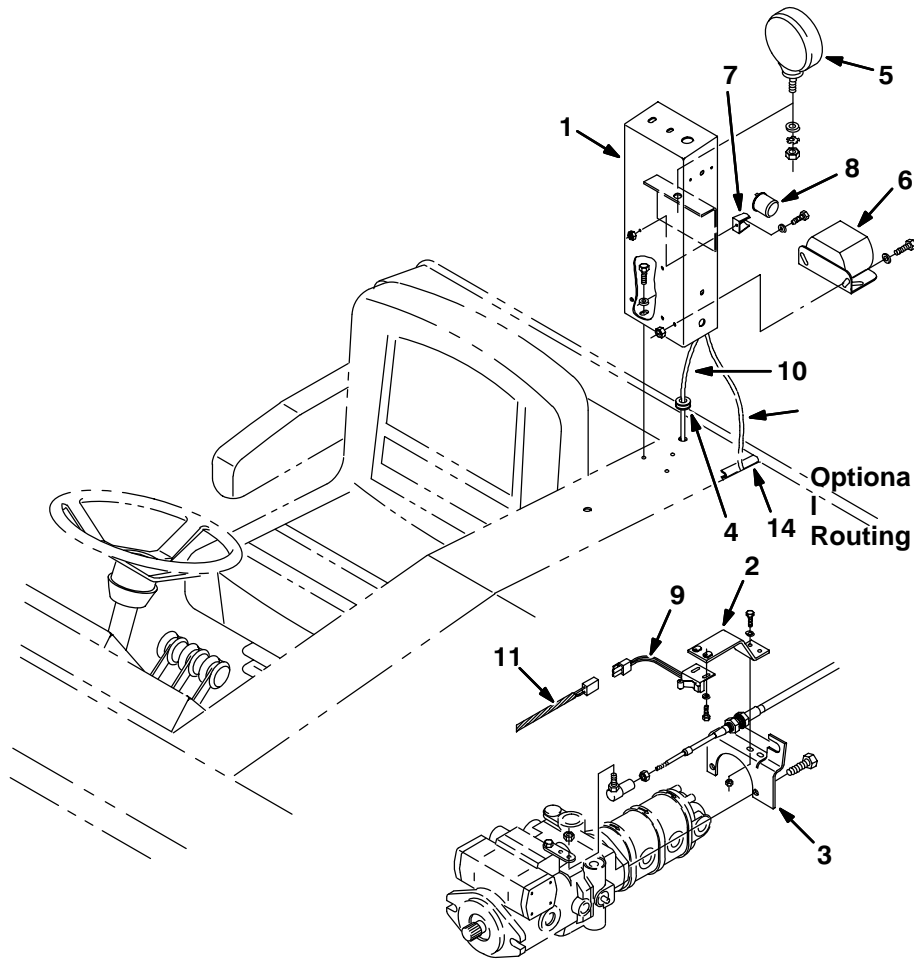

Fig. 7 – Back-Up Alarm Warning Kit



08758/08759

Ref.	Tennant Part No.	Machine Serial Number	Description	Qty.
▽	70696	(000000–) Warning Kit, Backup	1
1	76404	(000000–) Channel,	1
2	75568	(000000–) Bracket	1
3	76427	(000000–) Bracket, Mounting, Alarm Switch	1
4	10632–9	(000000–) Grommet, Rbr, 0.56ld, For .13Matl	1
▽	5	36438	(000000–) Headlight Assy, 210G	1
		36439	(000000–) Bulb, 12V .9A	1
6	61920	(000000–) Horn, Back-Up Alarm	1
7	24576–1	(000000–) Bracket, Flasher	1
8	24576	(000000–) Flasher, 12V. Ideal Co. Hd552Ps83	1
9	59965	(000000–) Switch, Roller	1
10	76415	(000000–) Harness, Alarm, Backup	1
11	76460	(000000–) Harness, Jumper, Backup	1
12	77423	(000000–) Duct, Vinyl 26.0"	1
13	86333	(000000–) Duct, Vinyl .40X.75X3.5 .25D	1
14	62595–18	(000000–) Molding, Trim 11–14Ga 3.00	1
15	29233	(000000–) Bumper, 3/32 Matl.	1

Fig. 8 – Back-Up Alarm Warning Kit, Blower Wand

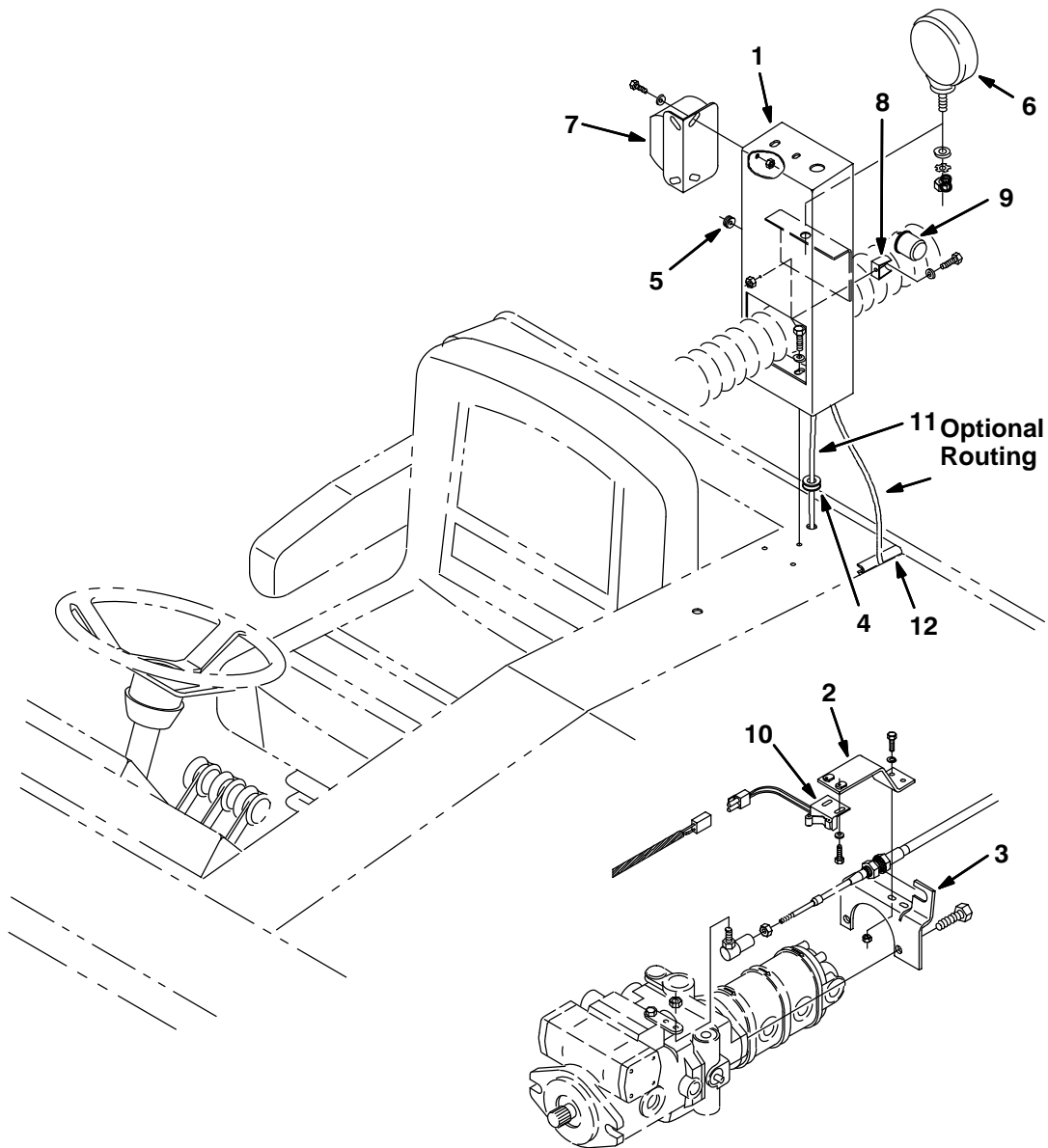

10400/10401

Ref.	Tennant Part No.	Machine Serial Number	Description	Qty.
▽	79554	(000000–) Warning Kit, Backup Low Blower	1
1	79513	(000000–) Channel Wldt, Blower Wand	1
2	75568	(000000–) Bracket	1
3	76427	(000000–) Bracket, Mounting, Alarm Switch	1
4	10632–9	(000000–) Grommet, Rbr, 0.56ld, For .13Matl	1
5	10632–5	(000000–) Grommet Rbr 0.25ld For .09Matl	1
▽	6	36438	(000000–) Headlight Assy, 210G	1
		36439	(000000–) Bulb, 12V .9A	1
7	61920	(000000–) Horn, Back-Up Alarm	1
8	24576–1	(000000–) Bracket, Flasher	1
9	24576	(000000–) Flasher, 12V. Ideal Co. Hd552Ps83	1
10	59965	(000000–) Switch, Roller	1
11	76415	(000000–) Harness, Alarm, Backup	1
12	62595–18	(000000–) Molding, Trim 11–14Ga 3.00	1

Fig. 9 – Overhead Guard Kit

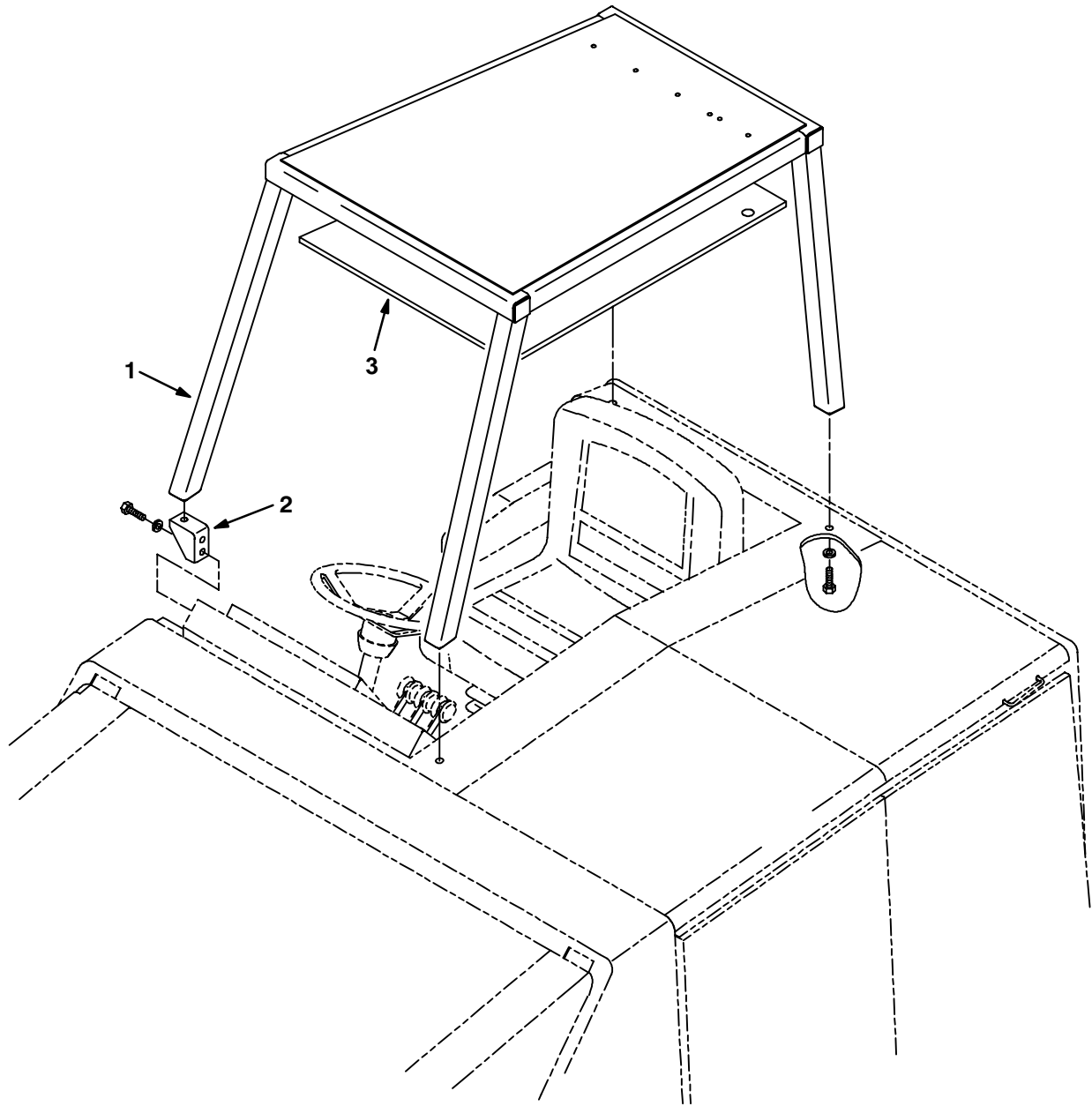

07651/07652

Ref.	Tennant Part No.	Machine Serial Number	Description	Qty.
∇	70669	(000000–)	Guard Kit, Overhead	1
1	65258	(000000–)	Guard Wldt, Overhead	1
2	70454	(000000–)	Bracket, Mtg, Ohg	1
3	74007	(000000–)	Foam, Insulation	1

Fig. 10 – Blower Group

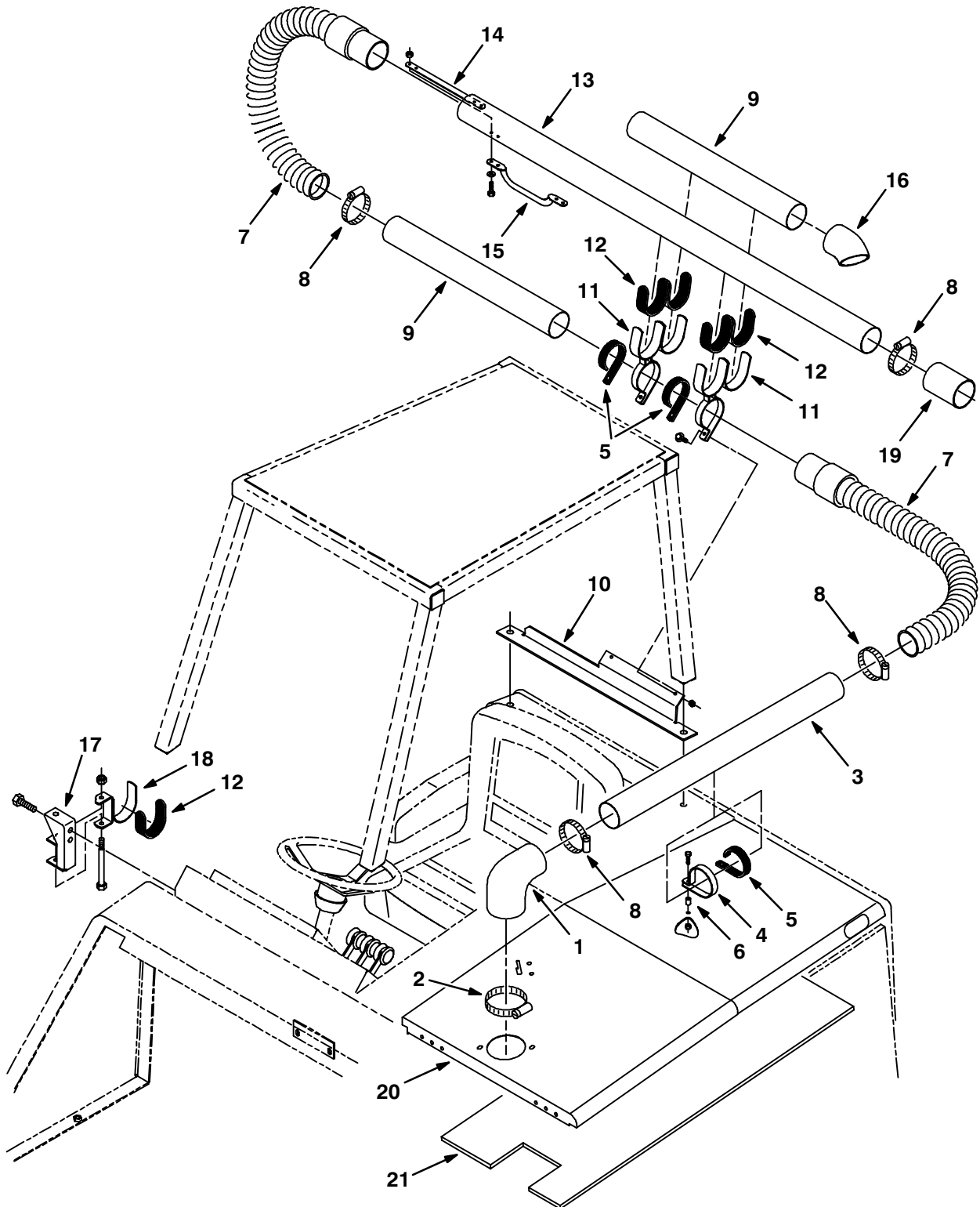

Fig. 10 – Blower Group

NOTE: Blower Kit, TENNANT Part Number 73776, includes Fig. 10, and Fig. 11.

Ref.	Tennant Part No.	Machine Serial Number	Description	Qty.
1	59919	(000000-xxxxxx)	Hose, Reducer	1
2	23498	(000000-xxxxxx)	Clamp-Wormdrive, 2.63- 4.50D	1
3	73692	(000000-xxxxxx)	Tube, Blower Wand	1
4	77631	(000000-xxxxxx)	Clamp, 3.250 Id	1
5	71025	(000000-xxxxxx)	Pad, Rubber	3
6	73675	(000000-xxxxxx)	Spacer	1
7	64320	(000000-xxxxxx)	Hose& Cuff Assy,Vinyl3.0Idx 24	2
8	43555	(000000-xxxxxx)	Clamp-Wormdrive, 1.62- 3.50D	4
9	73700	(000000-xxxxxx)	Tube, Blower Wand	2
10	73689	(000000-xxxxxx)	Bracket, Hose, Blower	1
11	76578	(000000-xxxxxx)	Clamp Wldt, Tube, Blower Wand	2
12	69981	(000000-xxxxxx)	Pad, Rubber	5
13	77743	(000000-001118)	Blower Tube Replacement Kit	1
14	69937	(000000-xxxxxx)	Plate, Backing, Handle	1
15	32822	(000000-xxxxxx)	Handle, Grab	1
16	73677	(000000-xxxxxx)	Hose, Rubber	1
17	73653	(000000-xxxxxx)	Bracket Wldt	1
18	69918	(000000-xxxxxx)	Bracket, Support, Blower	1
19	76575	(000000-xxxxxx)	Hose, Rubber	1
20	79012	(000000-xxxxxx)	Cover Wldt, Engine	1
21	73709	(000000-xxxxxx)	Bracket, Channel	1

Fig. 11 – Blower Vac Fan Group

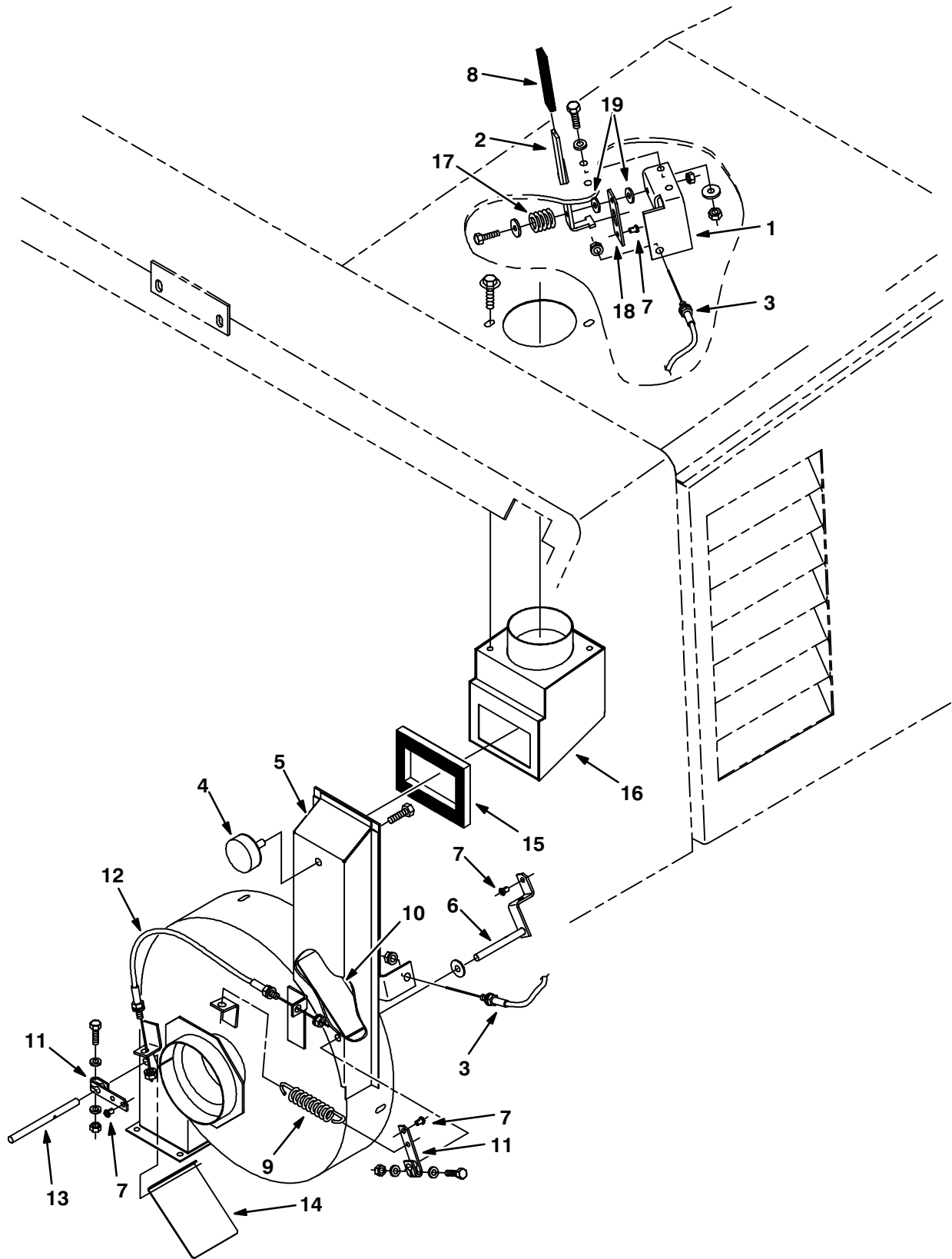

Fig. 11 – Blower Vac Fan Group

NOTE: Blower Kit, TENNANT Part Number 73776, includes Fig. 10, and Fig. 11.

Ref.	Tennant Part No.	Machine Serial Number	Description	Qty.
1	70870	(000000-xxxxxx)	Bracket, Mounting, Lever	1
2	70871	(000000-xxxxxx)	Lever, Blower	1
3	70879	(000000-xxxxxx)	Cable Assy	1
4	70756	(000000-xxxxxx)	Bumper, Rubber	1
5	73656	(000000-xxxxxx)	Housing Wldt, Vac Fan, Front	1
6	73671	(000000-xxxxxx)	Arm, Wldt, Outlet	1
7	43242	(000000-xxxxxx)	Swivel	4
8	87246	(000000-xxxxxx)	Grip Vinyl .18 X .75 X 4.00	1
9	01274	(000000-xxxxxx)	Sprng,Tens,0.965Odx.09Wire4.4L	1
10	73661	(000000-xxxxxx)	Plate, Damper, Outlet	1
11	73663	(000000-xxxxxx)	Arm, Couple	1
12	70878	(000000-xxxxxx)	Cable Assy	1
13	73660	(000000-xxxxxx)	Rod, Inlet	1
14	73664	(000000-xxxxxx)	Plate, Damper, Inlet	1
15	73655	(000000-xxxxxx)	Insulation, Acoustic, Fan	1
16	73674	(000000-xxxxxx)	Duct, Wldt	1
17	44853	(000000-xxxxxx)	Sprng,Comp,0.74Idx.11Wire 1.5L	1
18	76448	(000000-xxxxxx)	Plate, Lever	1
19	16236	(000000-xxxxxx)	Washer,Nyl,0.26 Bx0.72 X.07 Th	2

Fig. 12 – Blower Group

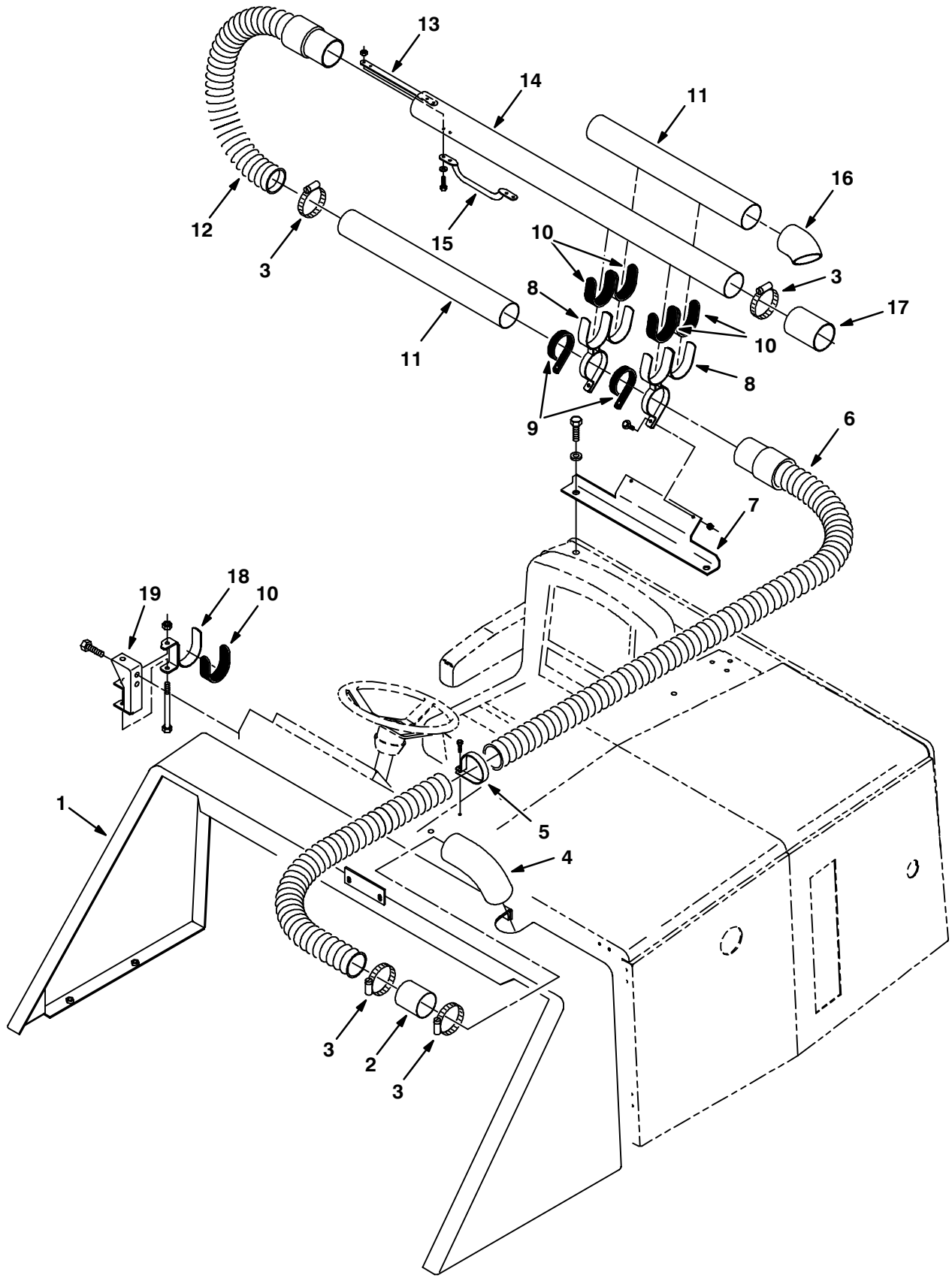

Fig. 12 – Blower Group

Ref.	Tennant Part No.	Machine Serial Number	Description	Qty.
1	77665	(xxxxxx-) Panel, Lintel	1
2	76945	(xxxxxx-) Tube, 3.00D 2.88B 3.00,Stl Dom	1
3	43555	(xxxxxx-) Clamp-Wormdrive, 1.62- 3.50D	4
4	75689	(xxxxxx-) Hose, Rubber, Elbow, 3.00	1
5	77631	(xxxxxx-) Clamp, 3.250 Id	1
6	79650	(xxxxxx-) Hose& Cuff Assy	1
7	73689	(xxxxxx-) Bracket, Hose, Blower	1
8	76578	(xxxxxx-) Clamp Wldt, Tube, Blower Wand	2
9	71025	(xxxxxx-) Pad, Rubber	2
10	69981	(xxxxxx-) Pad, Rubber	5
11	73700	(xxxxxx-) Tube, Blower Wand	2
12	64320	(xxxxxx-) Hose& Cuff Assy,Vinyl3.0ldx 24	1
13	69937	(xxxxxx-) Plate, Backing, Handle	1
14	77742	(001119-) Tube, Blower Wand	1
15	32822	(xxxxxx-) Handle, Grab	1
16	73677	(xxxxxx-) Hose, Rubber	1
17	76575	(xxxxxx-) Hose, Rubber	1
18	69918	(xxxxxx-) Bracket, Support, Blower	1
19	73653	(xxxxxx-) Bracket Wldt	1

Fig. 13 – Blower Vac Fan Group

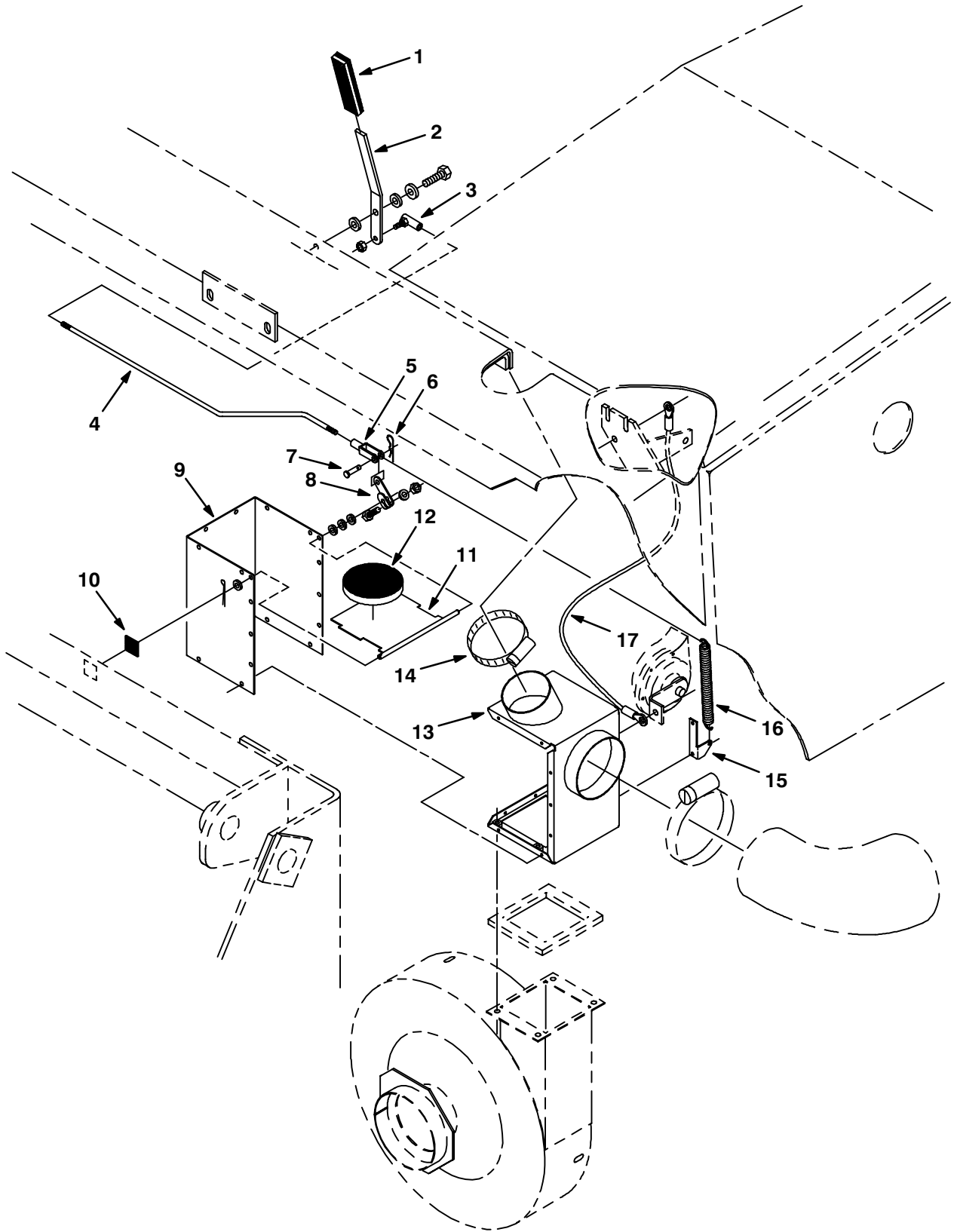
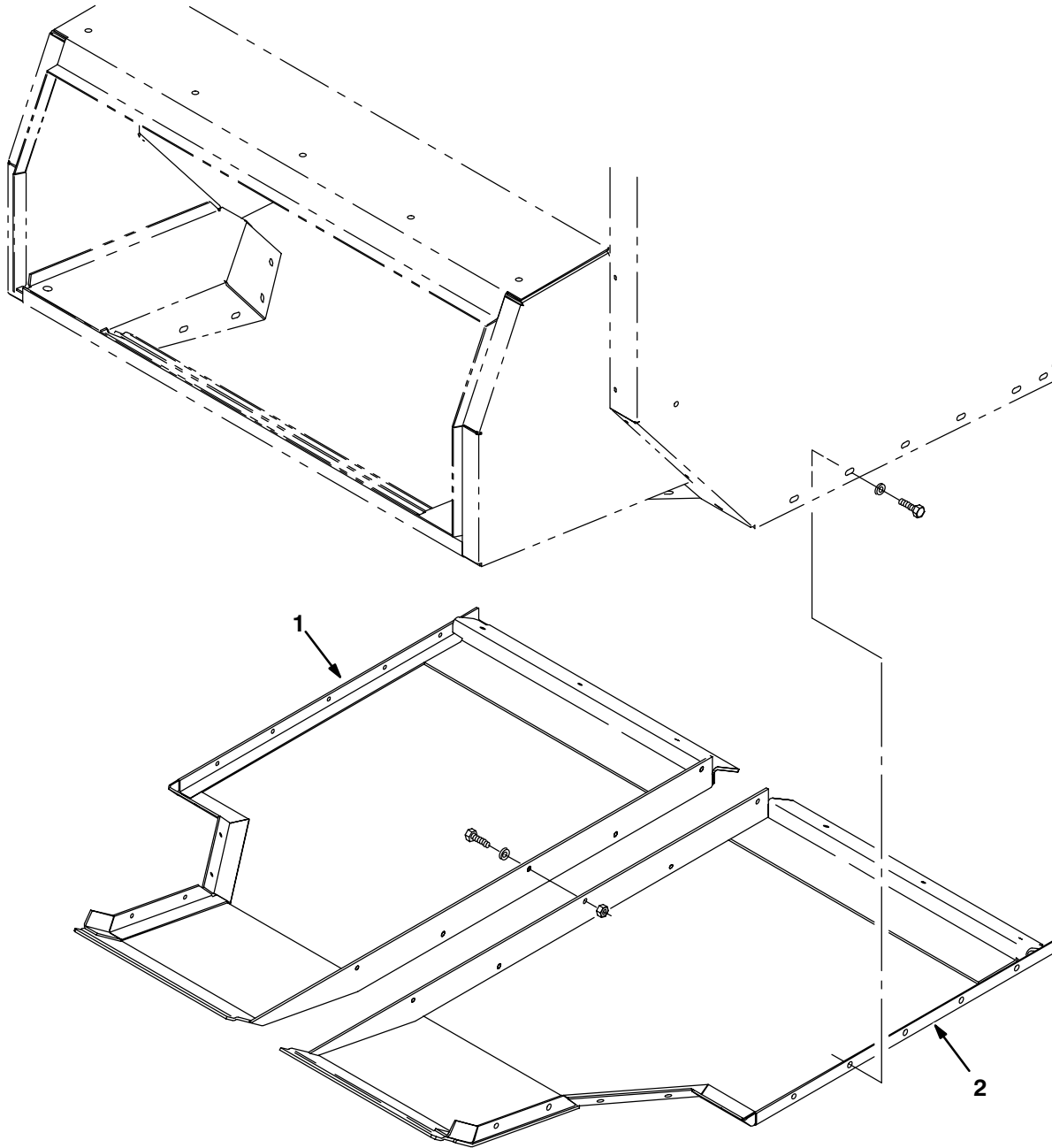

Fig. 13 – Blower Vac Fan Group

Ref.	Tennant Part No.	Machine Serial Number	Description	Qty.
1	87246	(xxxxxx-) Grip Vinyl .18 X .75 X 4.00	1
2	77662	(xxxxxx-) Lever	1
3	14601	(xxxxxx-) Ball Joint, 250-28	1
4	77629	(xxxxxx-) Rod, Push	1
5	14595-1	(xxxxxx-) Clevis, Adjust. 0.25-28Th. Cad.	1
6	08085	(xxxxxx-) Pin Hair Cotter .056Dx1.1L	1
7	14605	(xxxxxx-) Pin, Clevis, 0.25 Dia. X 0.75 Lg	1
8	30480	(xxxxxx-) Lever Carburetor	1
9	77538	(xxxxxx-) Panel, Vac Duct	1
10	21170	(xxxxxx-) Pad	1
11	77537	(xxxxxx-) Panel, Flap Valve	1
12	77671	(xxxxxx-) Insulation, S/Foam	1
13	77542	(xxxxxx-) Panel, Vac Duct	1
14	43555	(xxxxxx-) Clamp-Wormdrive, 1.62- 3.50D	1
15	77670	(xxxxxx-) Bracket	1
16	29260	(xxxxxx-) Sprng, Tens, 0.37Odx.05Wire 4.5L	1
17	82731	(xxxxxx-) Wire-Ground, Alternator	1

Fig. 14 – Hopper Floor Kit



07667/07668

Ref.	Tennant Part No.	Machine Serial Number	Description	Qty.
∇	70686	(000000–) Hopper Floor Kit, St Stil 800	1
1	77611	(000000–) Panel Wldt, Hopper, Floor, RH	1
2	77613	(000000–) Panel Wldt, Hopper, Floor, LH	1

Fig. 15 – Bumper Assembly, SE

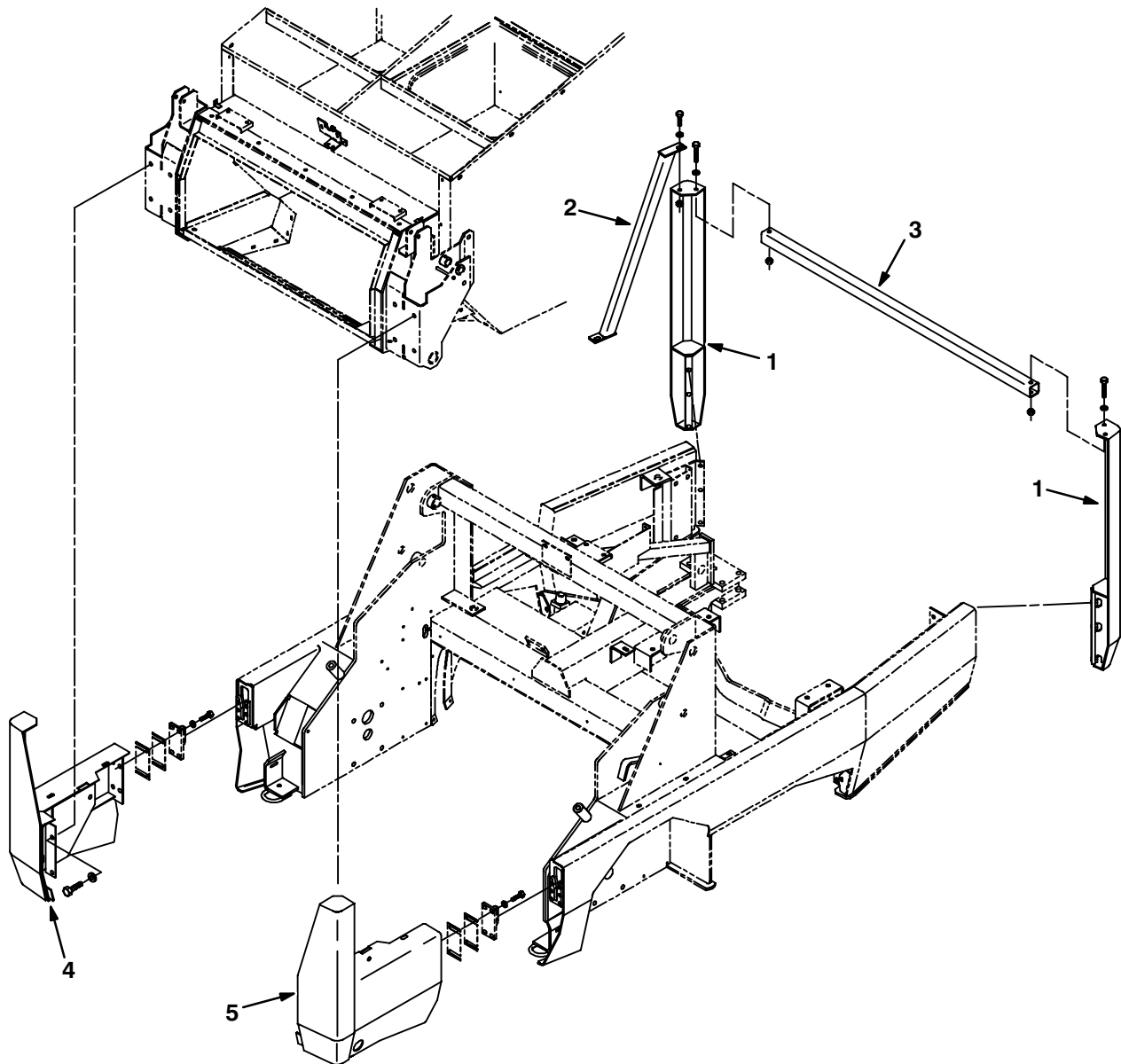

07683/07684

Ref.	Tennant Part No.	Machine Serial Number	Description	Qty.
▽	70684	(000000-001184)	Bumper Assy, Se	1
1	70802	(000000-001184)	Leg Wldt, Bumper, Se	2
2	70793	(000000-001184)	Brace Wldt, Bumper, Se	1
3	70815	(000000-001184)	Tube, Cross, Bumper, Se	1
4	70885	(000000-001184)	Leg Wldt, Bumper, Se	1
5	73688	(000000-001184)	Leg Wldt, Bumper, Se	1

Fig. 16 – Bumper Assembly, SE

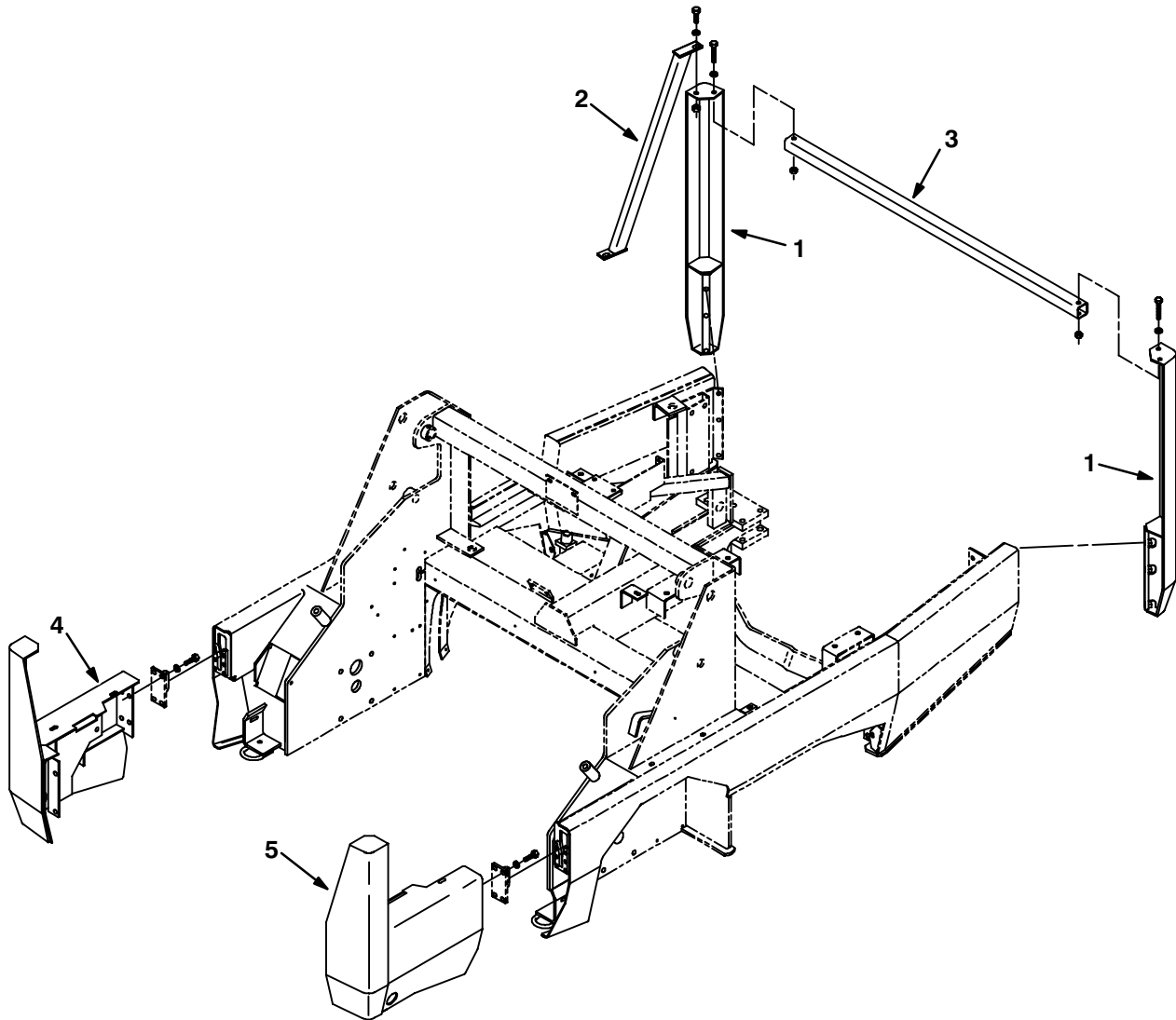

09908/09909

Ref.	Tennant Part No.	Machine Serial Number	Description	Qty.
▽	77545	(001185-001699)	Bumper Assy, Se	1
1	70802	(001185-001699)	Leg Wldt, Bumper, Se	2
2	70793	(001185-001699)	Brace Wldt, Bumper, Se	1
3	70815	(001185-001699)	Tube, Cross, Bumper, Se	1
4	77519	(001185-001699)	Bumper Wldt, Se, Rh, Front	1
5	77520	(001185-001699)	Bumper Wldt, Se, Lh, Front	1

Fig. 17 – Bumper Assembly, SE

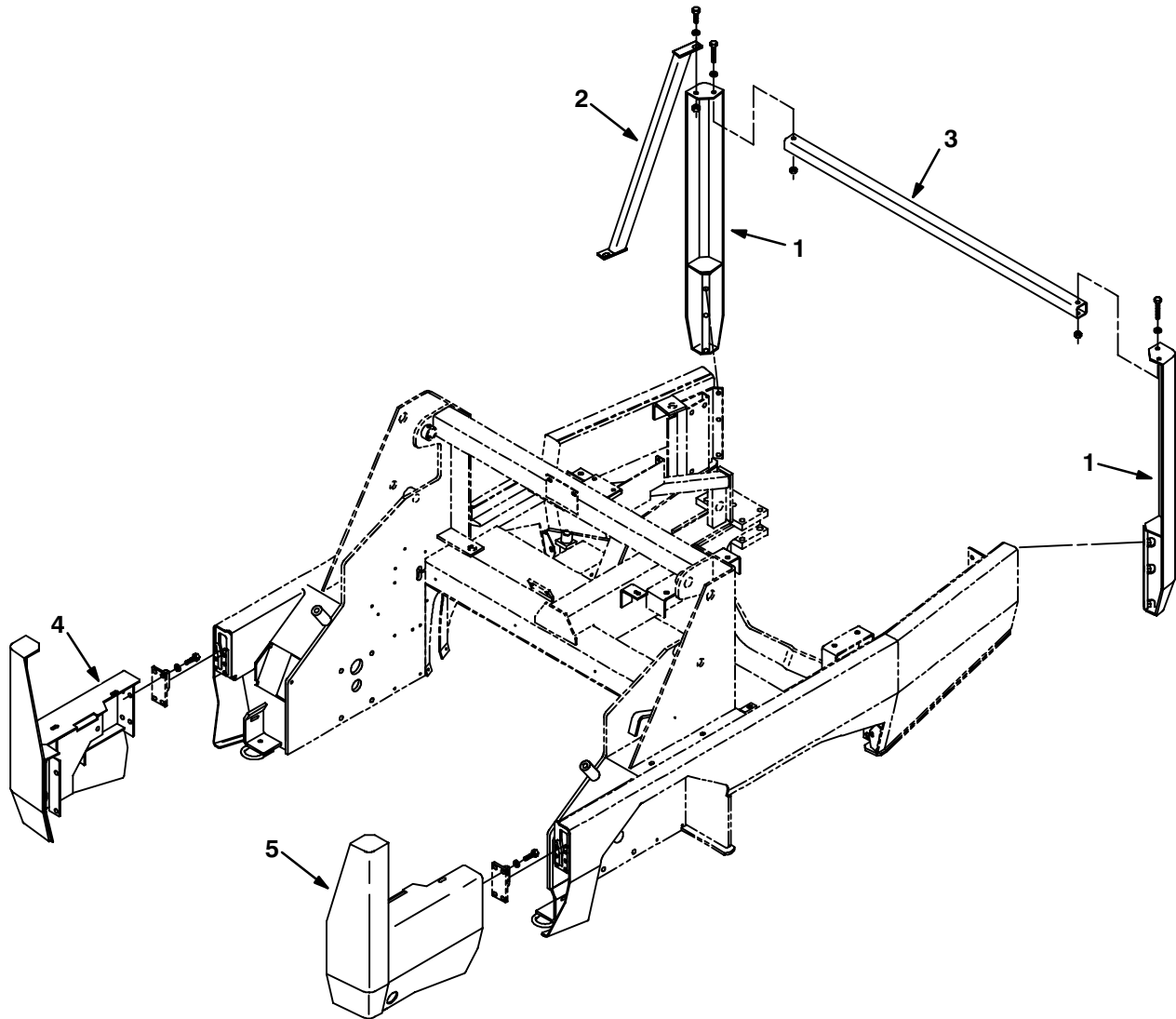

10506/09909

Ref.	Tennant Part No.	Machine Serial Number	Description	Qty.
▽	83557	(001700–)	Bumper Assy, Se	1
1	70802	(001700–)	Leg Wldt, Bumper, Se	2
2	70793	(001700–)	Brace Wldt, Bumper, Se	1
3	70815	(001700–)	Tube, Cross, Bumper, Se	1
4	83626	(001700–)	Bumper Wldt, Se, Rh, Front	1
5	83627	(001700–)	Bumper Wldt, Se, Lh, Front	1

Fig. 18 – Side Brush Lift Group, L.H.

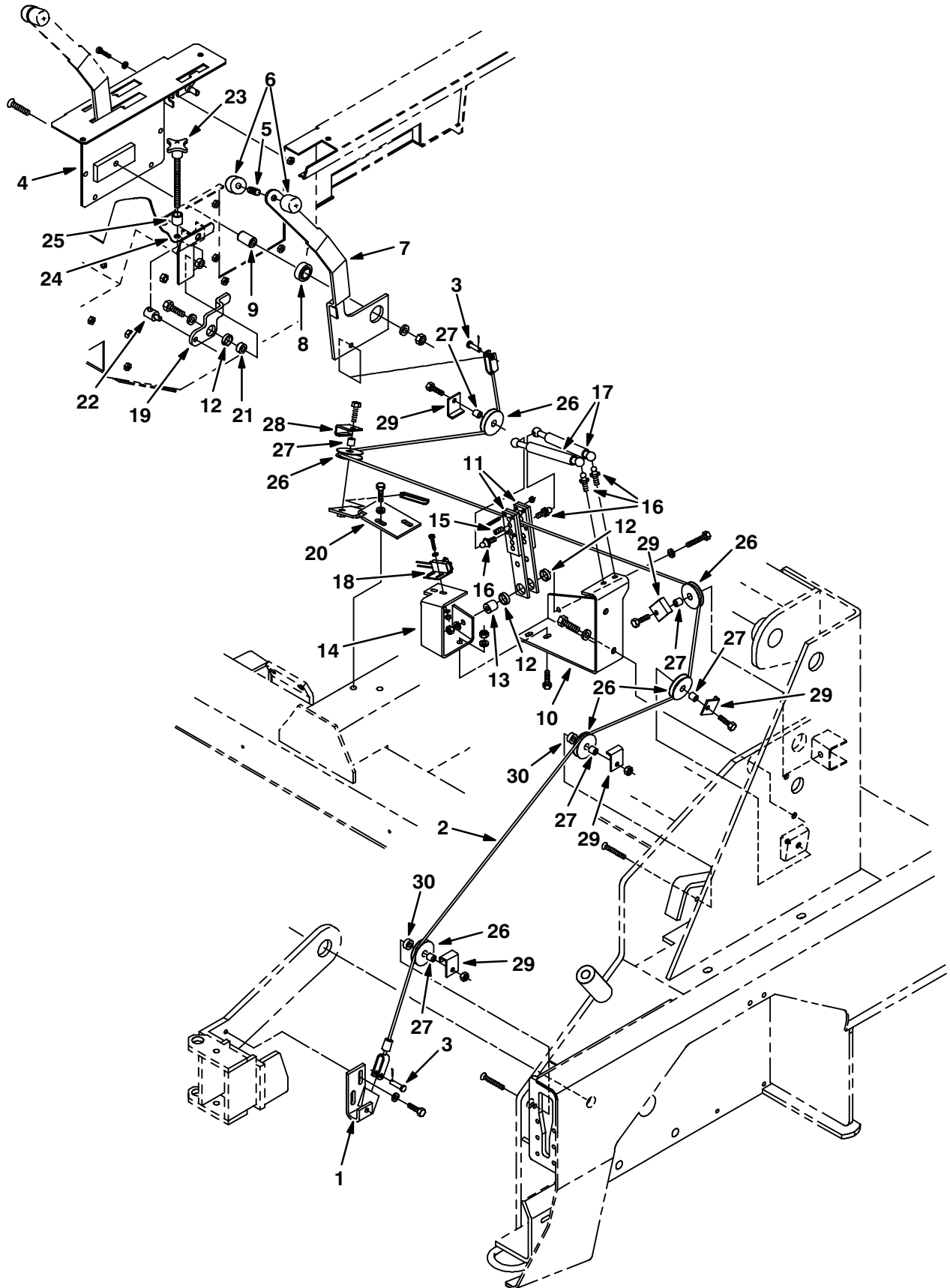

Fig. 18 – Side Brush Lift Group, L.H.

Ref.	Tennant Part No.	Machine Serial Number	Description	Qty.
1	75282	(000000-001176)	Bracket, Channel	1
2	75537	(000000-001176)	Cable Assy, Side Brush, Lift	1
3	69582	(000000-001176)	Pin,Clevis,0.31 Dia X 1.00 Lg	2
4	75870	(000000-001176)	Plate Wldt, Cover	1
5	75859	(000000-001176)	Rod-Thread, Full M10X1.5 X1.50	1
6	75857	(000000-001176)	Knob, Handle, Threaded	2
7	75022	(000000-001176)	Handle Wldt, Side Brush Lift	1
8	54663	(000000-001176)	Bearing, Self Aligning	1
9	75023	(000000-001176)	Spacer .77Od .406Id 1.318Lg	1
10	75491	(000000-001176)	Bracket Wldt	1
11	74031	(000000-001176)	Lever Wldt	2
12	74090	(000000-001176)	Bearing	3
13	73818	(000000-001176)	Sleeve, .375B .75D .75 Stl	1
14	75092	(000000-001176)	Bracket, Pivot	1
15	39338	(000000-001176)	Scr Set .31-18X0.50	1
16	58494	(000000-001176)	Stud, Ball, Gas Spring	4
17	73714	(000000-001176)	Strip, Retainer, Seal, Rh Gasspring	2
18	59962	(000000-001176)	Switch, Roller	1
19	70797	(000000-001176)	Lever	1
20	75082	(000000-001176)	Bracket, Mtg, Pulley	1
21	75894	(000000-001176)	Spacer	1
22	70444	(000000-001176)	Rod, Cam Adjuster	1
23	54848	(000000-001176)	Knob, Adjusting	1
24	52296	(000000-001176)	Washer,Nyl,0.405Bx0.812X.060Th	1
25	75892	(000000-001176)	Tube, .75D .172W .75 Stl	1
26	58279	(000000-001176)	Pulley – Cable, 1.5 Dia	6
27	56624	(000000-001176)	Spacer, Pulley	6
28	74899	(000000-001176)	Bracket, Cable Keeper	2
29	54400	(000000-001176)	Angle, Cable Keeper	4
30	73737	(000000-001176)	Sleeve, .375B .75D .32 Stl	2

Fig. 19 – Side Brush Lift Group, L.H.

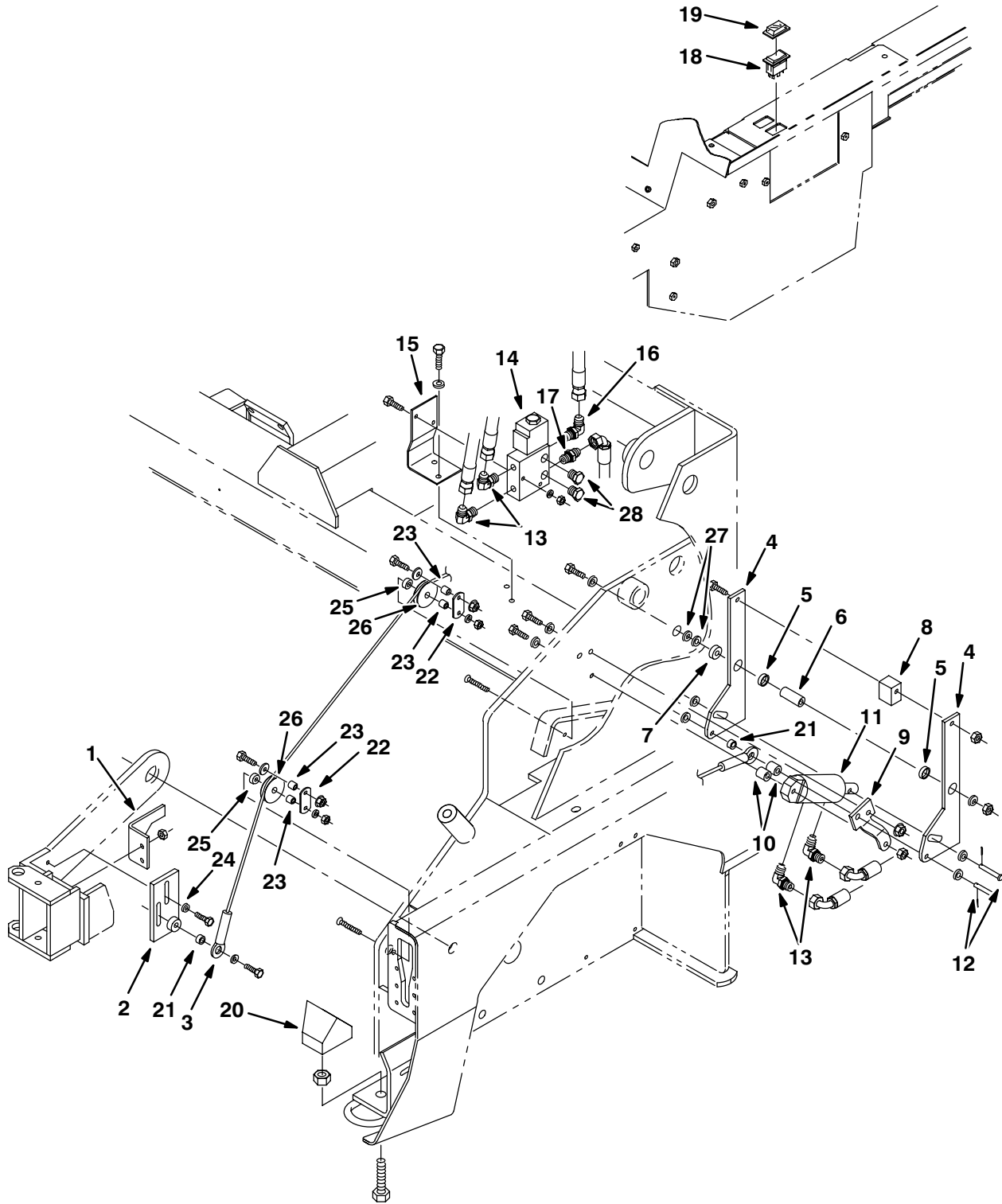

Fig. 19 – Side Brush Lift Group, L.H.

Ref.	Tennant Part No.	Machine Serial Number	Description	Qty.
1	77458	(001177–)	Bracket, Angle	1
2	77569	(001177–)	Plate Wldt	1
3	77568	(001177–)	Cable, Side Brush, Lift	1
4	77584	(001177–)	Plate	2
5	74090	(001177–)	Bearing	2
6	77597	(001177–)	Sleeve, 0.406B 0.75D1.80 Stl	1
7	77727	(001177–)	Sleeve .438B 1.00D .35Stl	1
8	77459	(001177–)	Spacer	1
9	77783	(001177–)	Plate, Angle	1
10	77600	(001177–)	Sleeve, 0.406B .750D .800Stl	2
11	77599	(001177–)	Cylinder, Hyd 1.5B 1.5S 2500	1
12	51813	(001177–)	Pin,Clevis,0.37 Dia.X 2.12 Lg	2
13	77097	(001177–)	Ftg–Hyd E90 Jm04/Om04	4
14	77771	(001177–001699)	Valve, Hyd, Control Solenoid	1
14	84016	(001700–)	Valve, Hyd, Solenoid (See Breakdowns)	1
15	21231	(001177–)	Bracket, Side Brush, Valve	1
16	56820	(001177–)	Ftg–Hyd E90 Jm06/Om06	1
17	56690	(001177–)	Ftg–Hyd Str Jm06/Om06	1
18	65561	(001177–)	Switch Rocker Spst	1
19	57807	(001177–)	Cover, Rocker Switch Seal	1
20	77738	(001177–)	Block	1
21	65174	(001177–)	Spacer	2
22	79115	(001177–)	Plate, Side Brush, Roller	2
23	56624	(001177–)	Spacer, Pulley	4
24	41186	(001177–)	Washer–Belleville .31 Pltd	1
25	73737	(001177–)	Sleeve, .375B .75D .32 Stl	2
26	58279	(001177–)	Pulley – Cable, 1.5 Dia	2
27	32492	(001177–)	Flat Washer, 3/8” Hard	2
28	46482	(001700–)	Ftg–Hyd Plg Om06	2

Fig. 20 – Side Brush Group, L.H.

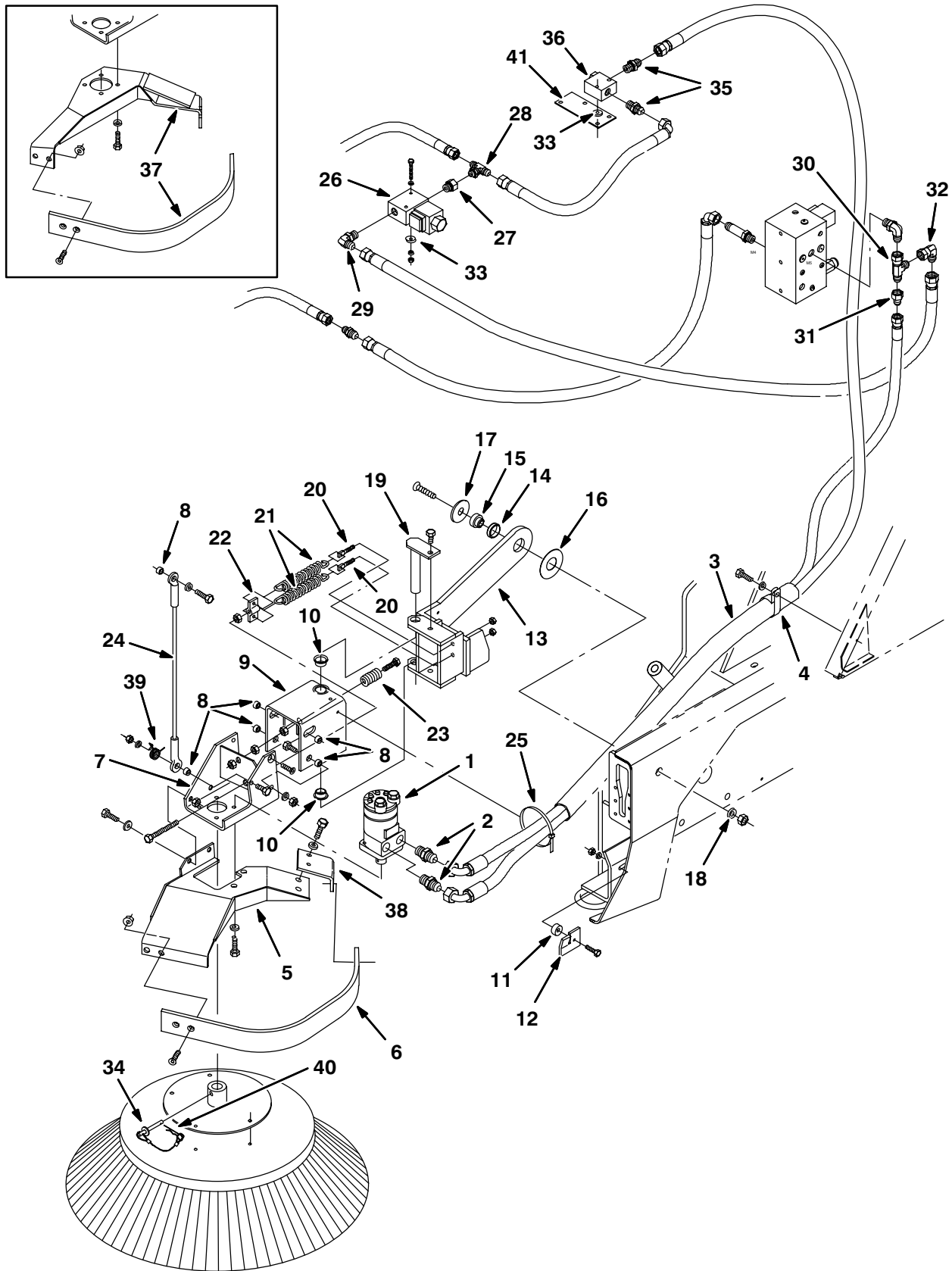
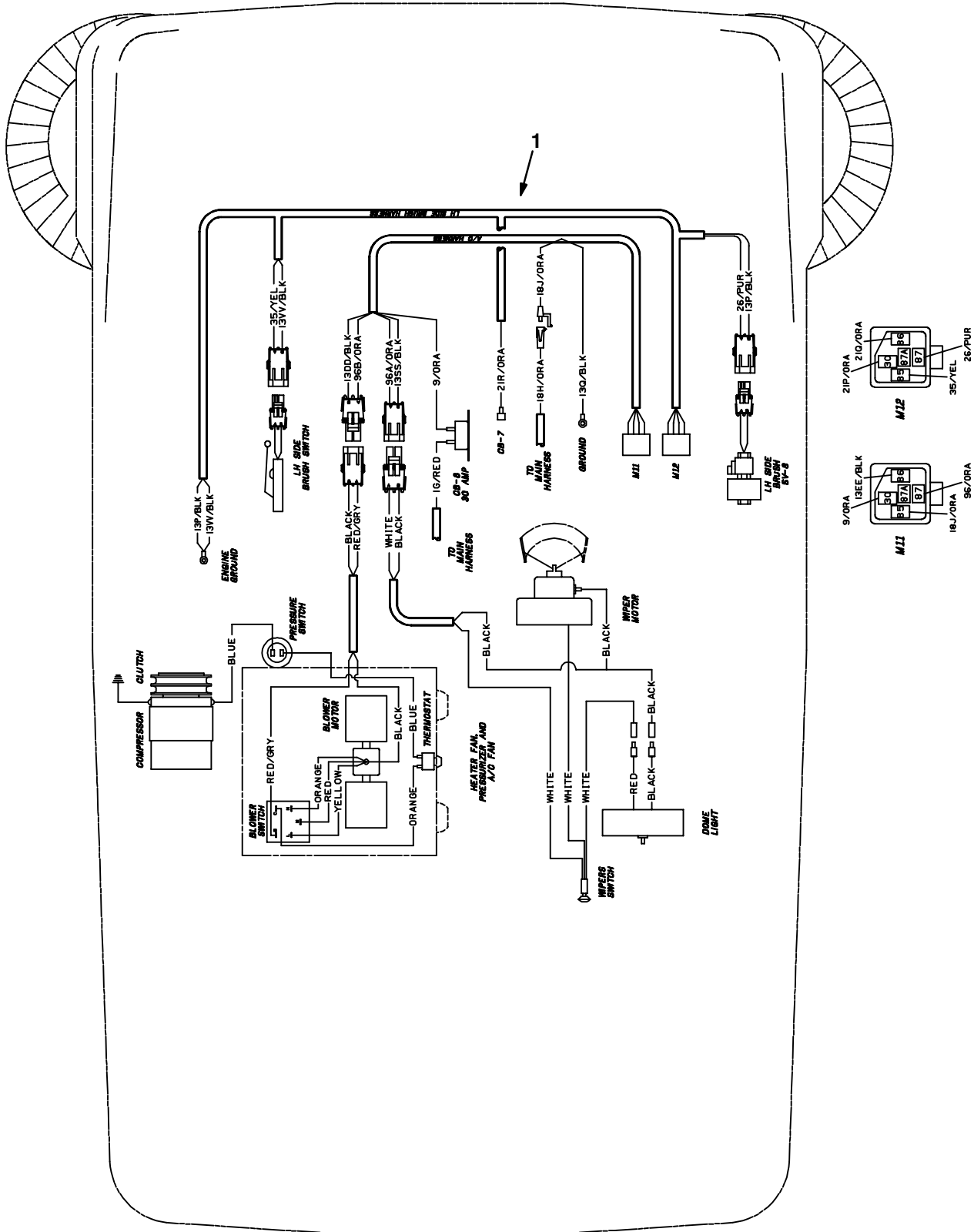

Fig. 20 – Side Brush Group, L.H.

Ref.	Tennant Part No.	Machine Serial Number	Description	Qty.
1	62564	(000000–001477)	Motor, Hyd (Repl. By 79781) (See Breakdowns)	1
1	79781	(001478–)	Motor, Hyd Gear In 17.9 B 1500 (See Breakdowns)	1
2	47508	(000000–)	Ftg–Hyd StrJm06/Om10	2
3	76461	(000000–)	Sleeve, Nylon #27 55.OI	1
4	86328	(000000–)	Clamp, Cable 1.5 Dia	1
5	21250	(001340–)	Guard Wldt, Sidebrush	1
6	21252	(001340–)	Guard, Side Brush	1
7	75142	(000000–)	Bracket, Mounting, Motor	1
8	65174	(000000–)	Spacer	6
9	75099	(000000–)	Bracket Wldt, Pivot	1
10	04761	(000000–)	Bearing, Flange .875 Bore	2
11	74059	(000000–)	Spacer	1
12	75899	(000000–)	Bracket, Angle	1
13	75117	(000000–)	Bracket Wldt, Lift	1
14	70627	(000000–)	Bearing	1
15	70526	(000000–)	Shaft, Pivot	1
16	70524	(000000–)	Washer, 1.300B 3.000	1
17	70525	(000000–)	Spacer	1
18	36328	(000000–)	Washer–Belleville .50 Pltd	1
19	70431	(000000–)	Pin	1
20	70626	(000000–)	Bolt–Eye M8–1.25	2
21	65160	(000000–)	Spring, Extension	2
22	65173	(000000–)	Bracket, Spring	1
23	65180	(000000–)	Spring, Comp	1
24	70532	(000000–)	Cable, Retaining, Side Brush	1
25	49263	(000000–)	Tie Cable 3.00D Max 11.41Lg	1
26	65391	(000000–001699)	Valve–Hyd, Solenoid (See Breakdowns)	1
26	84015	(001700–)	Valve–Hyd, Solenoid (See Breakdowns)	1
27	47637	(000000–)	Ftg–Hyd Str Om08/Of06	1
28	67683	(000000–)	Ftg–Hyd Tee Jm06Omjm	1
29	44868	(000000–)	Ftg–Hyd E90 Jm08/Om08	1
30	45482	(000000–)	Ftg–Hyd Tee Jm08Jmjf	1
31	47753	(000000–)	Ftg–Hyd Str Jm06/Jf08	1
32	17980	(000000–)	Ftg–Hyd E90 Jm08/Jf08	1
33	63416	(000000–)	Washer, .310B .88D .12Rbr	4
34	21035	(000000–)	Pin Assy, .312X3.0 W/Lanyard	1
35	56690	(000000–)	Ftg–Hyd Str Jm06/Om06	2
36	79621	(000000–)	Check Valve, 100 Psi	1
37	21253	(000000–001339)	Guard Replmt Kit Side Brush Lh	1
38	21251	(001340–)	Plate, Angle	1
39	79124	(000000–)	Spring, Torsion	1
40	44906	(000000–)	Pin,Hair Cotter #Lhcot–2,Leitk	1
41	79622	(000000–)	Plate, Mtg, Check Valve	1

Fig. 21 – Side Brush Wire Harness Group, L.H.



08776/08564

Ref.	Tennant Part No.	Machine Serial Number	Description	Qty.
1	77726	(00000-001699)	Harness, Side Brush, L.H.	1

Fig. 22 – Side Brush Wire Harness Group, L.H.

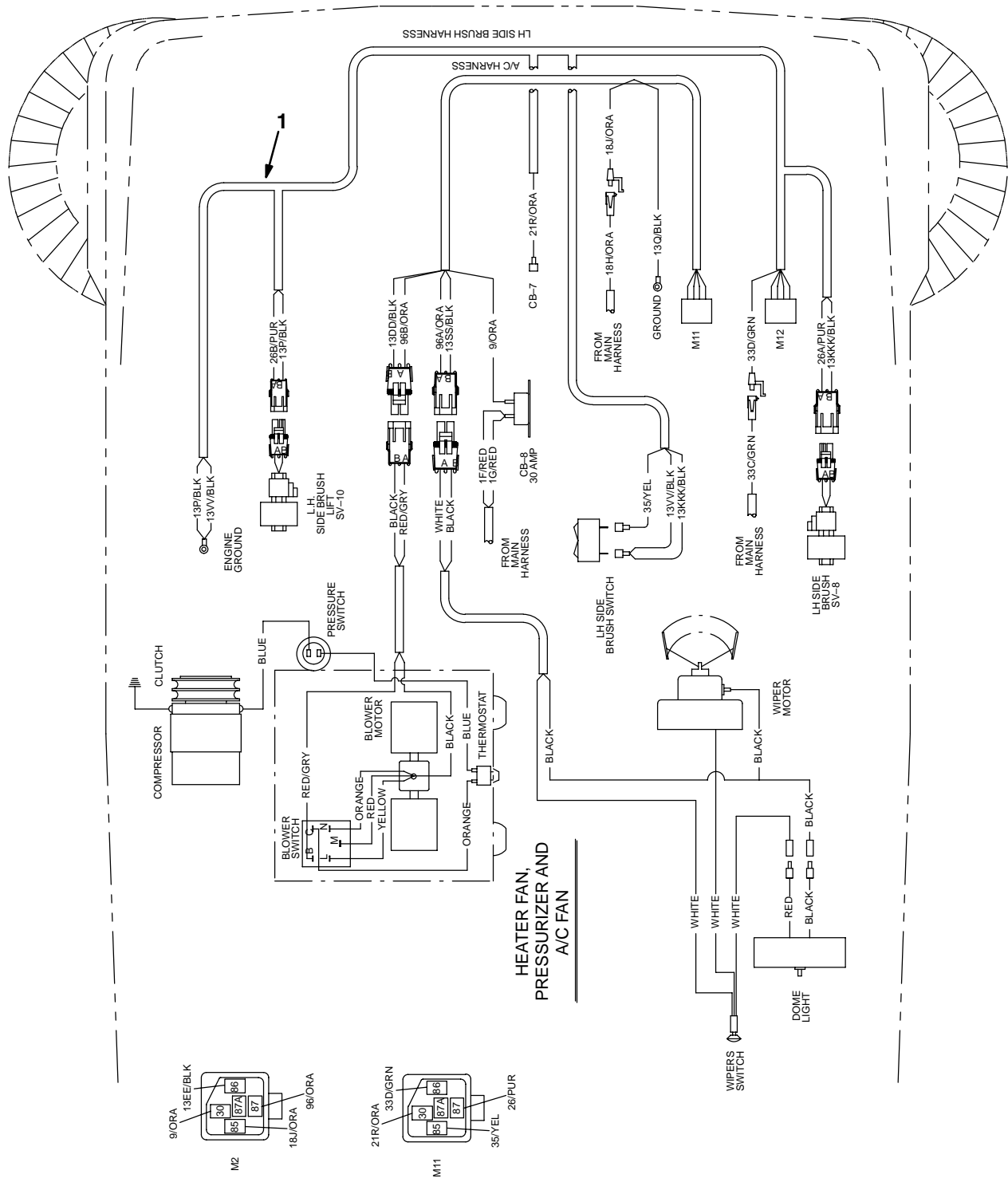

10505/10501

Ref.	Tennant Part No.	Machine Serial Number	Description	Qty.
1	83699	(001700–)	Harness, Side Brush, L.H.	1

Fig. 23 – Side Brush Hydraulic Hose Group, L.H.

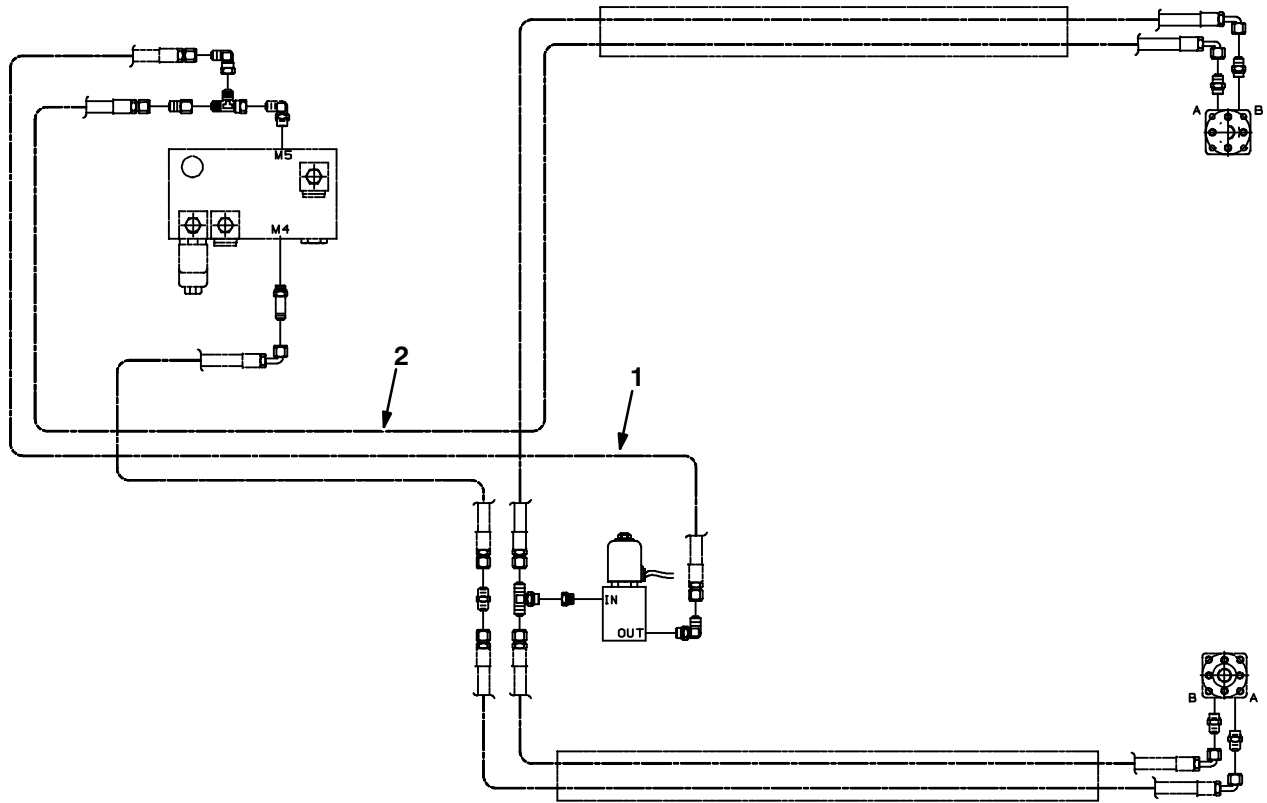

08762/08763

Ref.	Tennant Part No.	Machine Serial Number	Description	Qty.
1	76684	(000000-001176)	Hose-Hyd Med06 Jf/J9	1
2	31597	(000000-001176)	Hose-Hyd Med06 Jf/J9	1

Fig. 24 – Side Brush Hydraulic Hose Group, L.H.

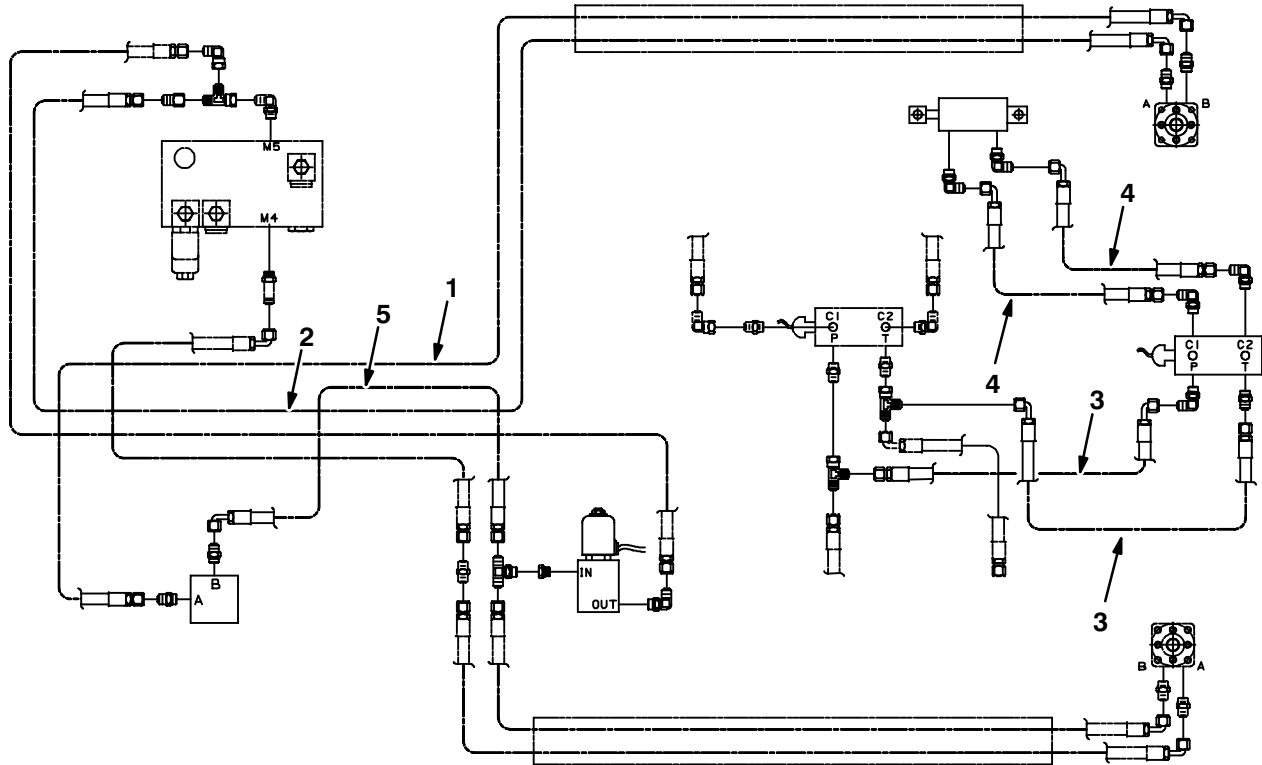

09913/08763

Ref.	Tennant Part No.	Machine Serial Number	Description	Qty.
1	76684	(001177-) Hose-Hyd Med 06	1
2	65194	(001177-) Hose-Hyd Med 06	1
3	78998	(001177-) Hose-Hyd Med 06	2
4	57963	(001177-) Hose-Hyd Med 04	2
5	01999	(001259-) Hose-Hyd Med 06	1

Fig. 25 – Side Brush Light Group

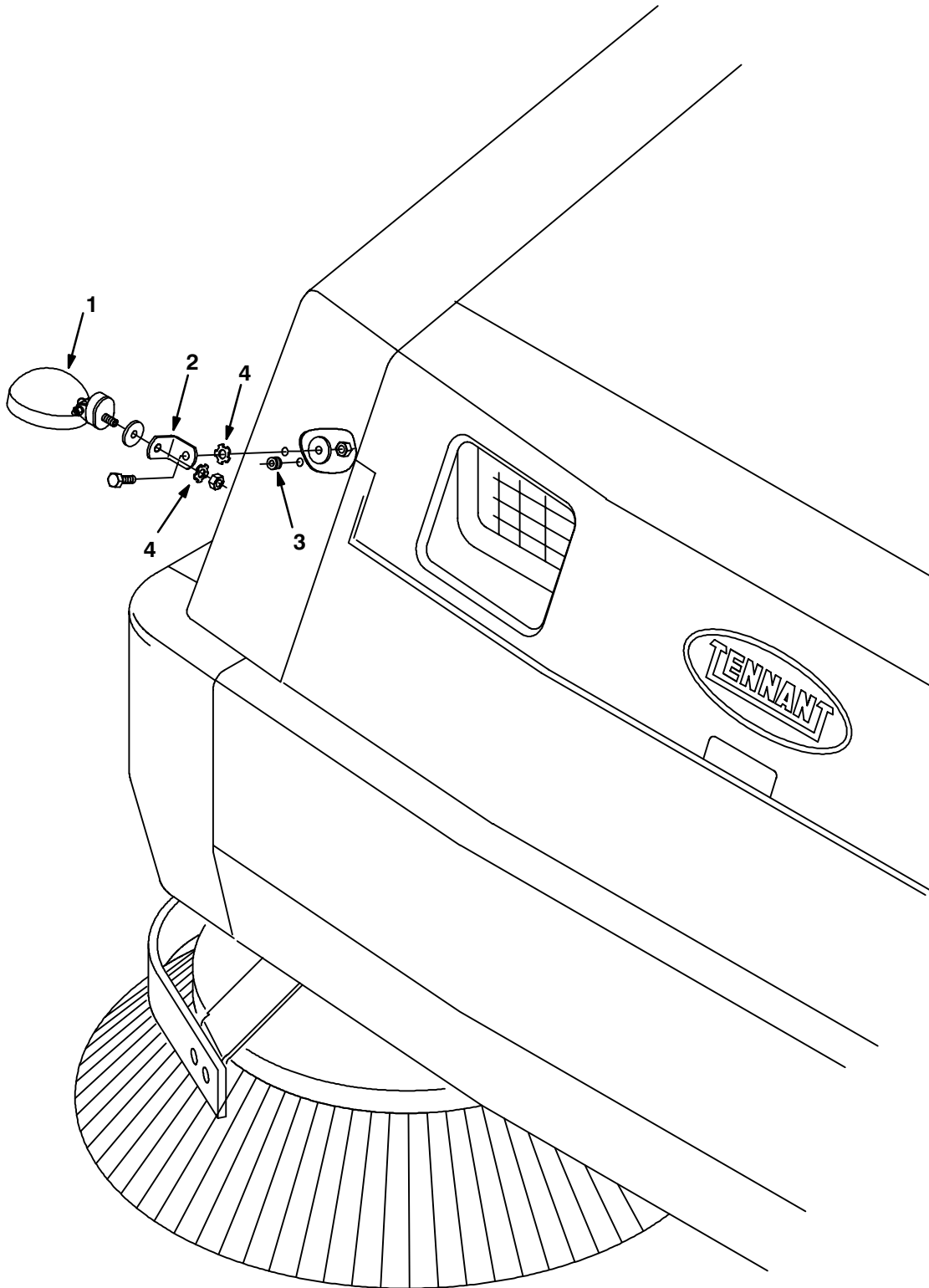

Fig. 25 – Side Brush Light Group

Ref.	Tennant Part No.	Machine Serial Number	Description	Qty.
∇	70699	(000000–) Light Kit, Side Brush	1
1	61424	(000000–) Light, Spot Hi–D 255li L	1
2	76385	(000000–) Bracket, Angle	1
3	10632–5	(000000–) Grommet Rbr 0.25ld For .09Matl	1
4	41141	(000000–) Washer–Loc Int–Ext .31 Pltd	2

Fig. 26 – Cab Group

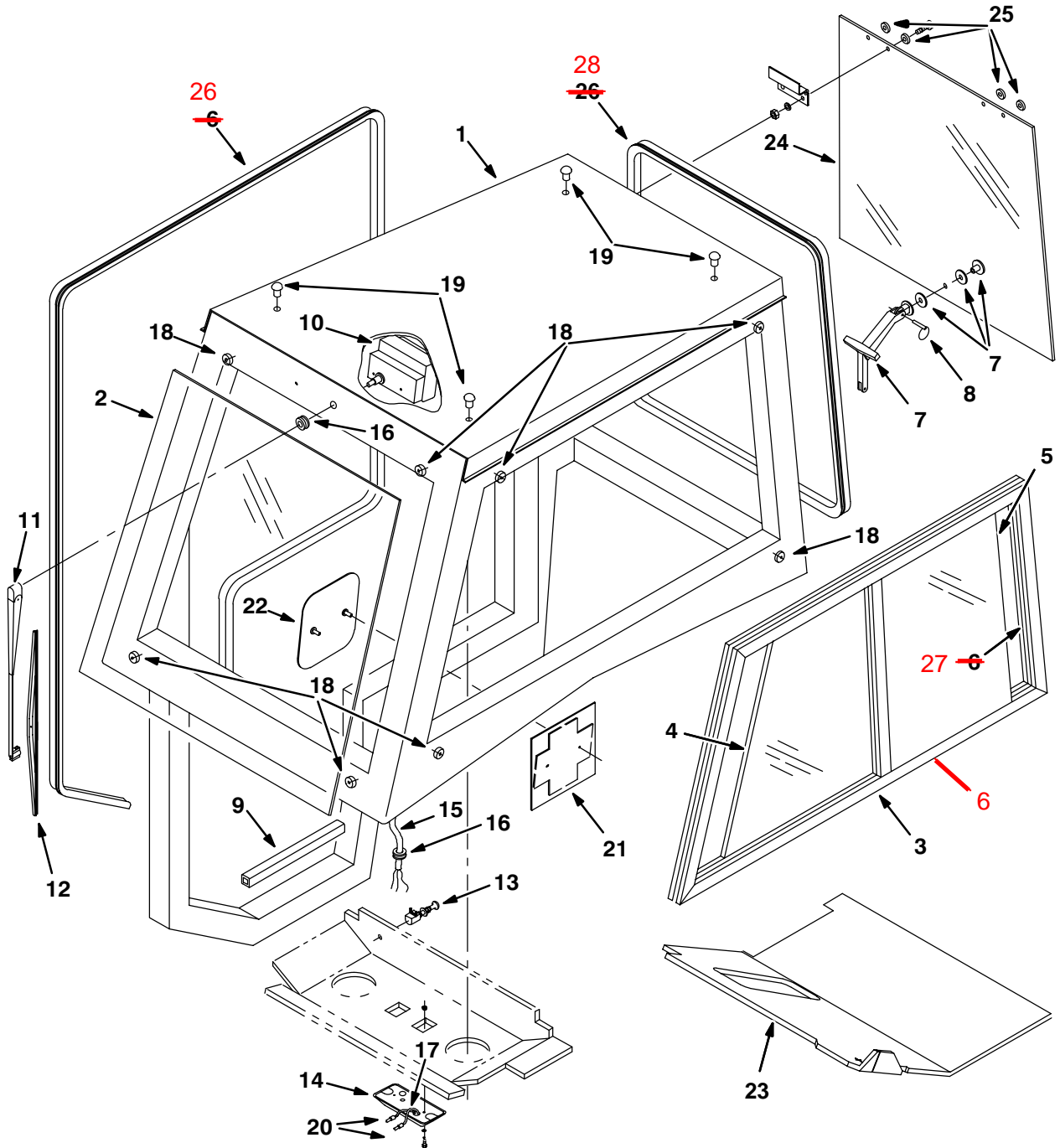

Fig. 26 – Cab Group

Ref.	Tenant Part No.	Machine Serial Number	Description	Qty.
1	75820	(000000–)	Cab Body	1
2	75822	(000000–)	Glass, Windshield	1
∇ 3	75823	(000000–)	Glass, Sliding, Lh	1
▲ 4	21307	(000000–)	Frnt Glass Asy–Cab	1
▲ 5	21308	(000000–)	Rear Glass Asy–Cab	1
▲ 6	21309	(000000–)	Frame Asy–Cab	1
7	76950	(000000–)	Latch, Rear Wind	1
8	76971	(000000–)	Ring, Rear Window	1
9	76973	(000000–)	Seal Cw	1
10	76977	(000000–)	Motor, Wiper 12V	1
11	76980	(000000–)	Arm, Rear Wiper	1
12	76982	(000000–)	Blade Arm, Rear	1
13	76985	(000000–)	Switch, Wiper Motor	1
14	76996	(000000–)	Light, Dome 12V	1
15	77810	(000000–)	Harness, Wire	1
16	77811	(000000–)	Grommet	2
17	77812	(000000–)	Wire, Dome Light	2
18	77813	(000000–)	Spacer	8
19	77814	(000000–)	Closure	4
20	77815	(000000–)	Disconnect, Male	2
21	70785	(000000–)	Bracket Wldt, Cab, Lpg	1
22	70788	(000000–)	Cover, Cab, Lpg	1
23	76522	(000000–)	Tread, Floormat, Rubber, Cab	1
24	75824	(000000–)	Glass, Rear	1
25	75825	(000000–)	Spacer, Glass	4
26	76948	(000000–)	Gasket, Push On	1
27	21310	(000000–)	Seal Kit, Cab	1
28	380695	(00000–)	Seal, Rear Window	1

Fig. 27 – Cab Door Assembly

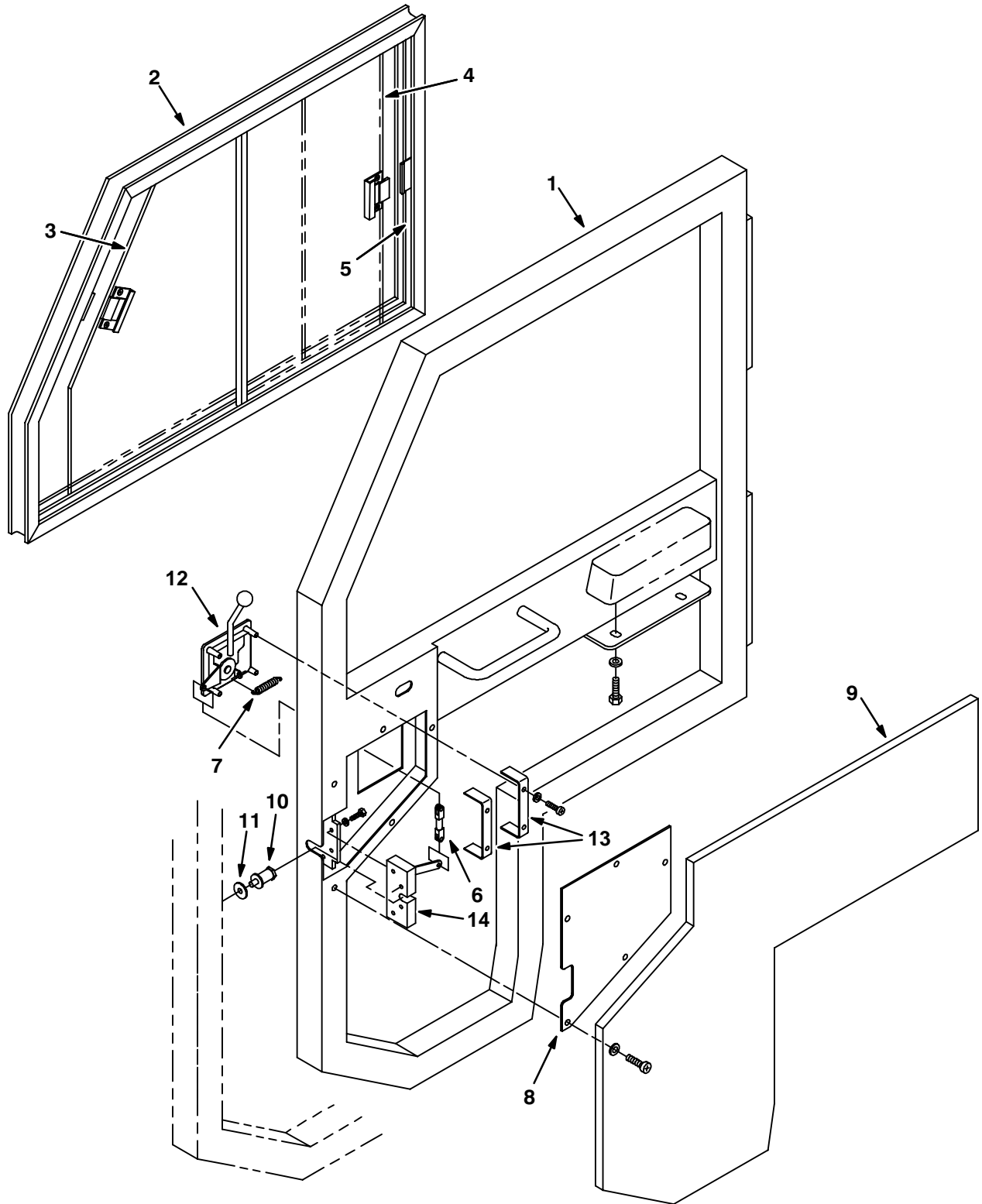

Fig. 27 – Cab Door Assembly

Ref.	Tennant Part No.	Machine Serial Number	Description	Qty.
∇	75821	(000000–)	Door Group	1
1	77816	(000000–)	Door Cw	1
∇	2	77817	(000000–) Sliding Glass	1
3	21311	(000000–)	Frnt Glass Asy–Door	1
4	21312	(000000–)	Rear Glass Asy–Door	1
5	21313	(000000–)	Frame Assy–Door	1
6	77821	(000000–)	Link, Connecting	1
7	77822	(000000–)	Pin Assy, Spring	2
8	77823	(000000–)	Plate	1
9	77824	(000000–)	Foam, Door	1
10	76975	(000000–)	Striker Assy	1
11	76976	(000000–)	Shim, Door Striker	2
∇	12	77818	(000000–) Paddle Handle	1
		21150	(000000–) Key Set	1
13	77819	(000000–)	Bracket	2
14	77820	(000000–)	Clam Latch	1

Fig. 28 – Cab Insulation Group

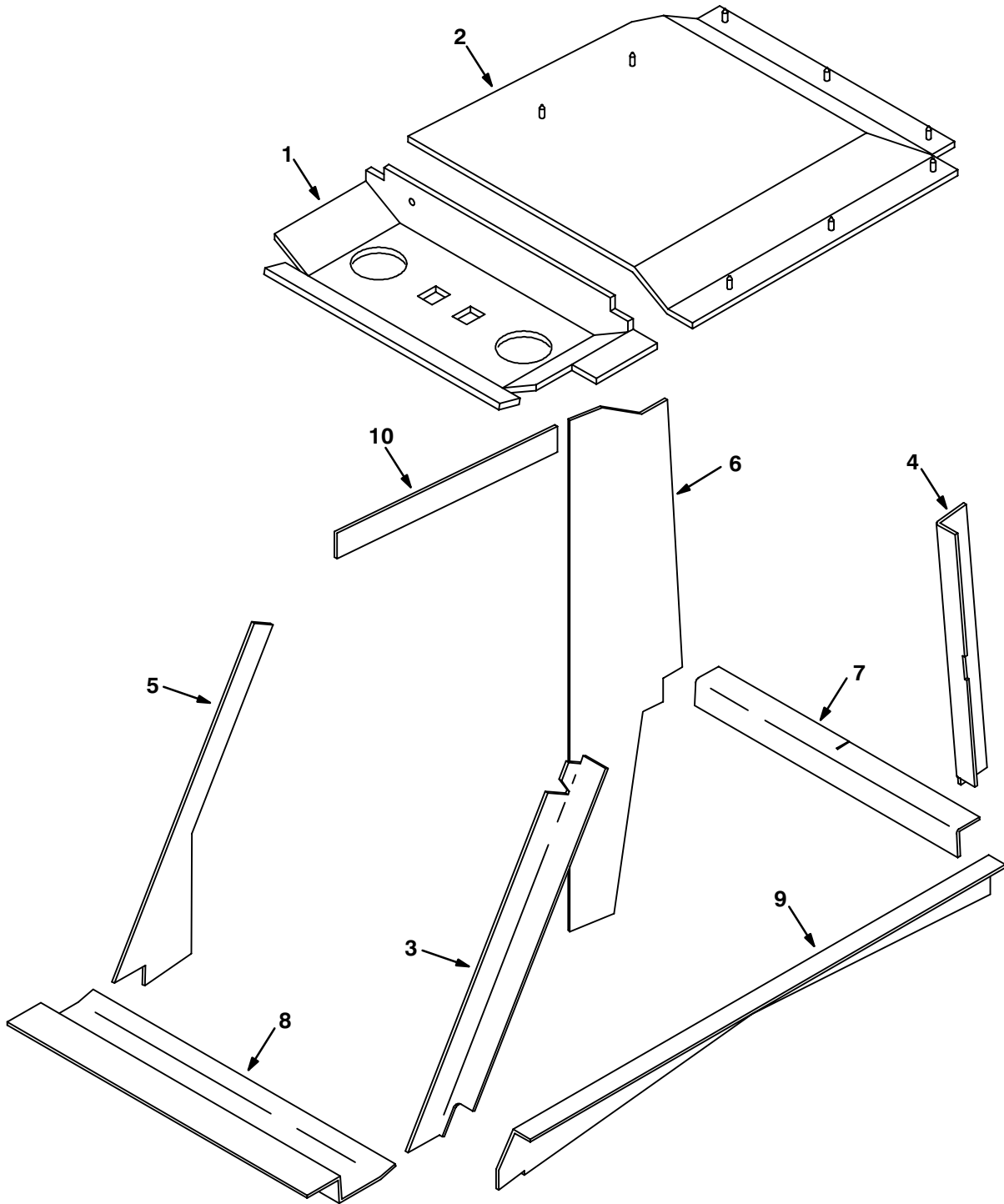

Fig. 28 – Cab Insulation Group

Ref.	Tennant Part No.	Machine Serial Number	Description	Qty.
1	77800	(000000–)	Headliner, Front	1
2	77801	(000000–)	Headliner, Rear Cw	1
3	77802	(000000–)	Foam, Lh Front Pos	1
4	77803	(000000–)	Foam, Lh Rear Pos	1
5	77804	(000000–)	Foam, Rh Front Pos	1
6	77805	(000000–)	Foam, Rh Rear Pos	1
7	77806	(000000–)	Foam, Rear Sill	1
8	77807	(000000–)	Foam, Front Sill	1
9	77808	(000000–)	Foam, Lh Side Sill	1
10	77809	(000000–)	Foam, Rh Upper Sill	1

Fig. 29 – Mirror Kit

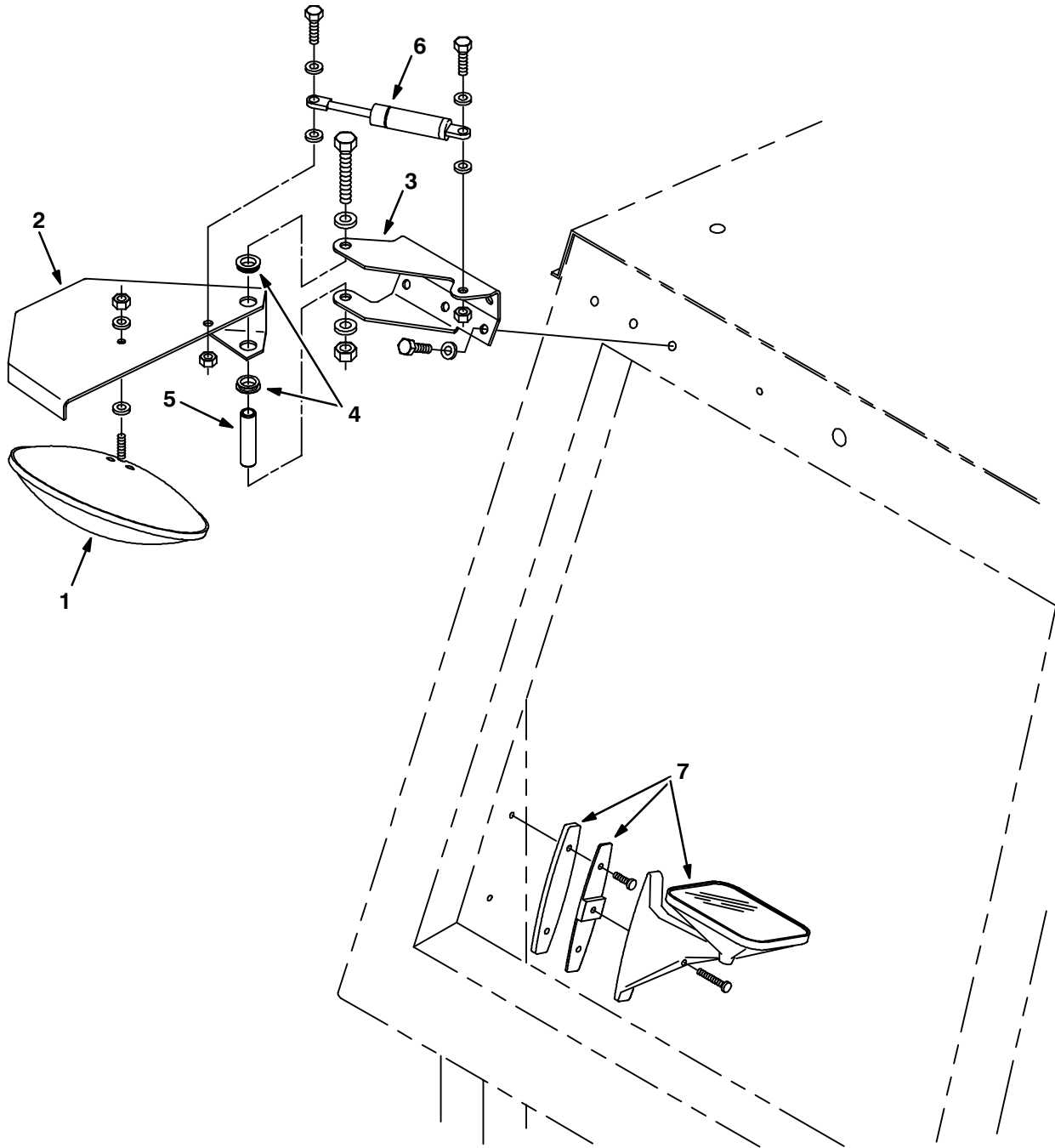

Fig. 29 – Mirror Kit

Ref.	Tennant Part No.	Machine Serial Number	Description	Qty.
∇	76898	(000000–) Mirror Kit, Side Brush	1
1	68445	(000000–) Mirror,8.0 Round,Convex	1
2	75881	(000000–) Guard, Mirror	1
3	75880	(000000–) Bracket, Mounting, Mirror	1
4	41434	(000000–) Bshg,Flange,0.62Bx0.68Od,Nylon	2
5	70761	(000000–) Tube, 0.62D .44B 2.44, Stl	1
6	12549	(000000–) Spring, Gas 80 Lb	1
7	75882	(000000–) Mirror, Side Brush	1

Fig. 30 – Air Cleaner Assembly, Air Conditioner

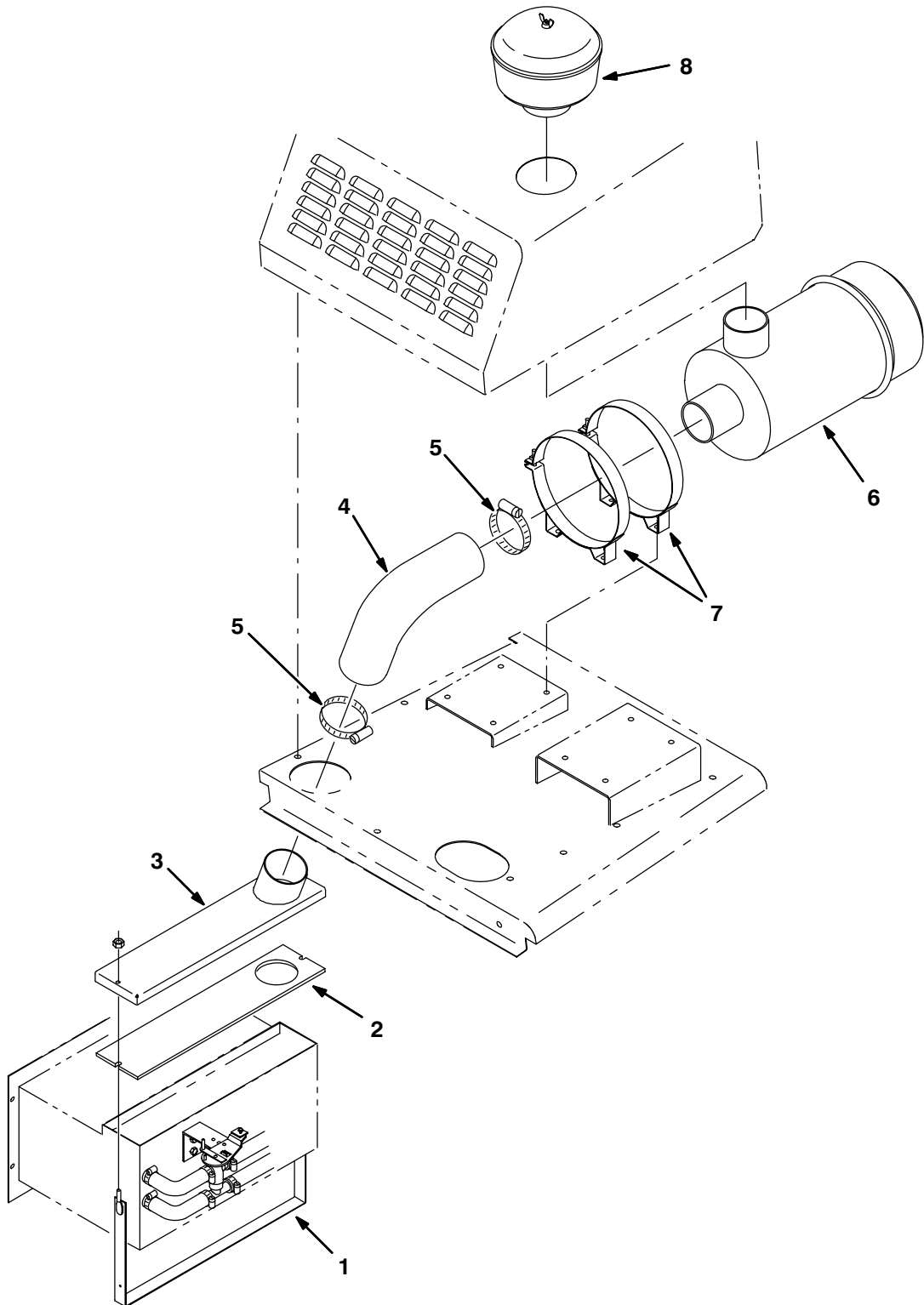

Fig. 30 – Air Cleaner Assembly, Air Conditioner

Ref.	Tennant Part No.	Machine Serial Number	Description	Qty.
∇	75890	(000000–)	Air Cleaner Assy, Air Cond	1
1	75875	(000000–)	Strap Wldt, A/C Cover	1
2	21216	(000000–)	Gasket, Air Cond Box	1
3	75192	(000000–)	Cover Wldt, Air Cond Box	1
4	75304	(000000–)	Hose, Rubber, Elbow	1
5	43555	(000000–)	Clamp–Wormdrive, 1.62– 3.50D	2
6	75609	(000000–)	Filter, Air, A/C	1
7	75606	(000000–)	Strap, Mtg, Air Cleaner	2
8	75666	(000000–)	Filter, Pre–Cleaner, A/C	1

Fig. 31 – Air Conditioner Group

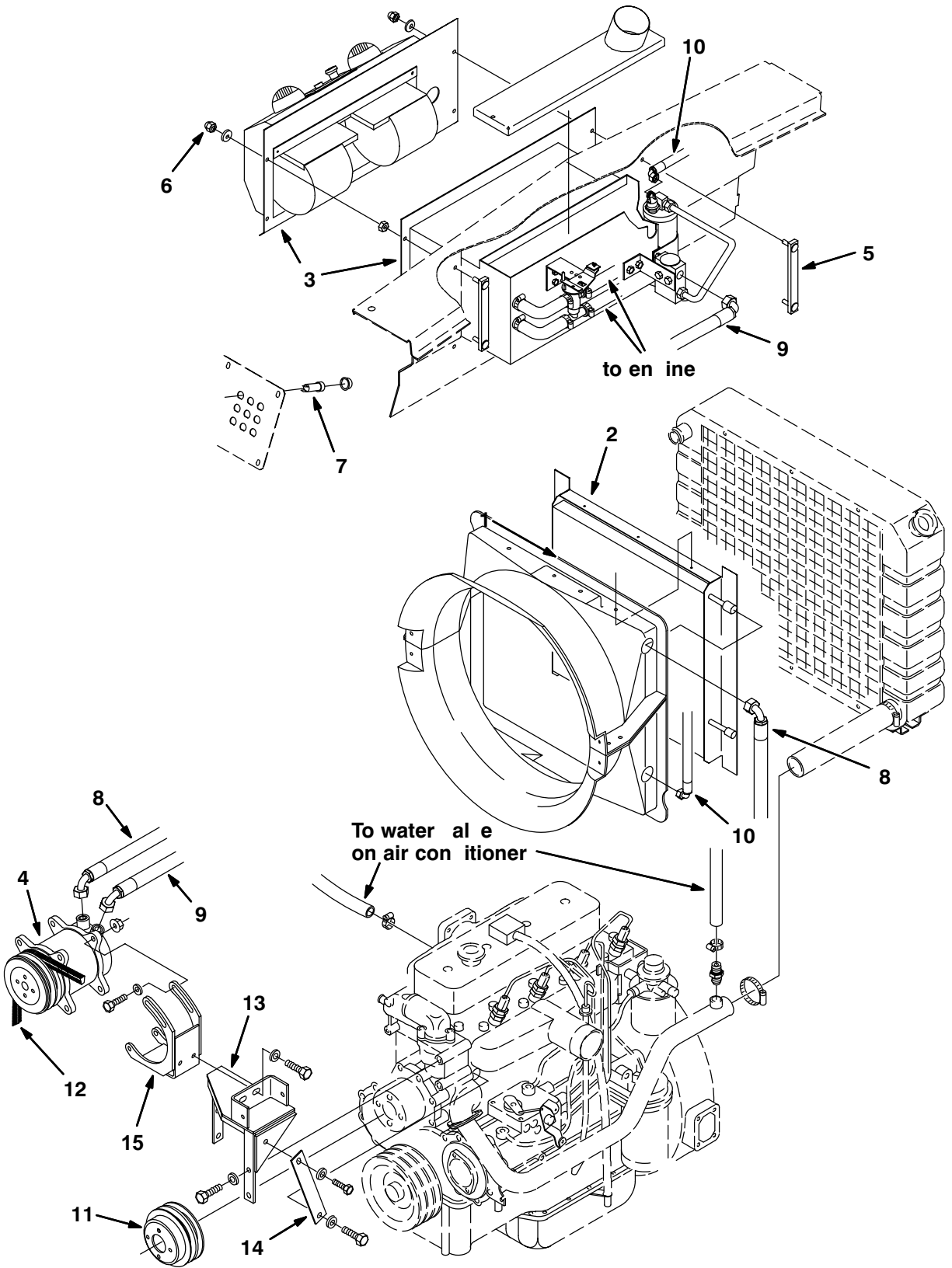

Fig. 31 – Air Conditioner Group

Ref.	Tenant Part No.	Machine Serial Number	Description	Qty.
1	75866	(000000–)	Duct, Fan, Ac	1
2	73858	(000000–)	Condensor, Air Conditioner	1
3	77675	(000000–001397)	Air Conditioner, A 134 (Repl. By 21270) (See Breakdowns)	1
3	21270	(001398–)	Air Conditioner 134R Recirc (See Breakdowns)	1
4	77869	(000000–001157)	Compressor R12	1
4	77674	(001158–)	Compressor, A/C	1
5	75884	(000000–)	Strip	2
6	41128	(000000–)	Nut–Low Crown .31–18 Pltd	4
7	76473	(000000–)	Breaker–Circuit, 30 Thermal	1
	76437	(000000–)	Harness, Air Conditioner	1
∇	8	21277	(000000–001157) A/C Hose #8 R12 De	1
		32134	(000000–001157) O–Ring, #8	2
∇	8	21274	(001158–) Hose, A/C #8 134A	1
		32134	(001158–) O–Ring, #8	2
∇	9	21278	(000000–001157) A/C Hose #10 R12 De	1
		32147	(000000–001157) O–Ring	2
∇	9	21275	(001158–) Hose, A/C #10	1
		32147	(001158–) O–Ring	2
∇	10	21276	(000000–001157) A/C Hose #6 R12 De	1
		32133	(000000–001157) O–Ring #6	4
∇	10	21273	(001158–) A/C Hose #6 134A De	1
		32133	(001158–) O–Ring #6	4
	11	70513	(000000–) Sheave, Machining	1
	12	76270	(000000–) Belt, Vhc–50 X 61	1
	13	70489	(000000–) Bracket, Mounting, Compressor	1
	14	77628	(000000–) Brace	1
	15	76297	(000000–) Plate Wldt, Compressor	1

Fig. 32 – Heater/Pressurizer Assembly

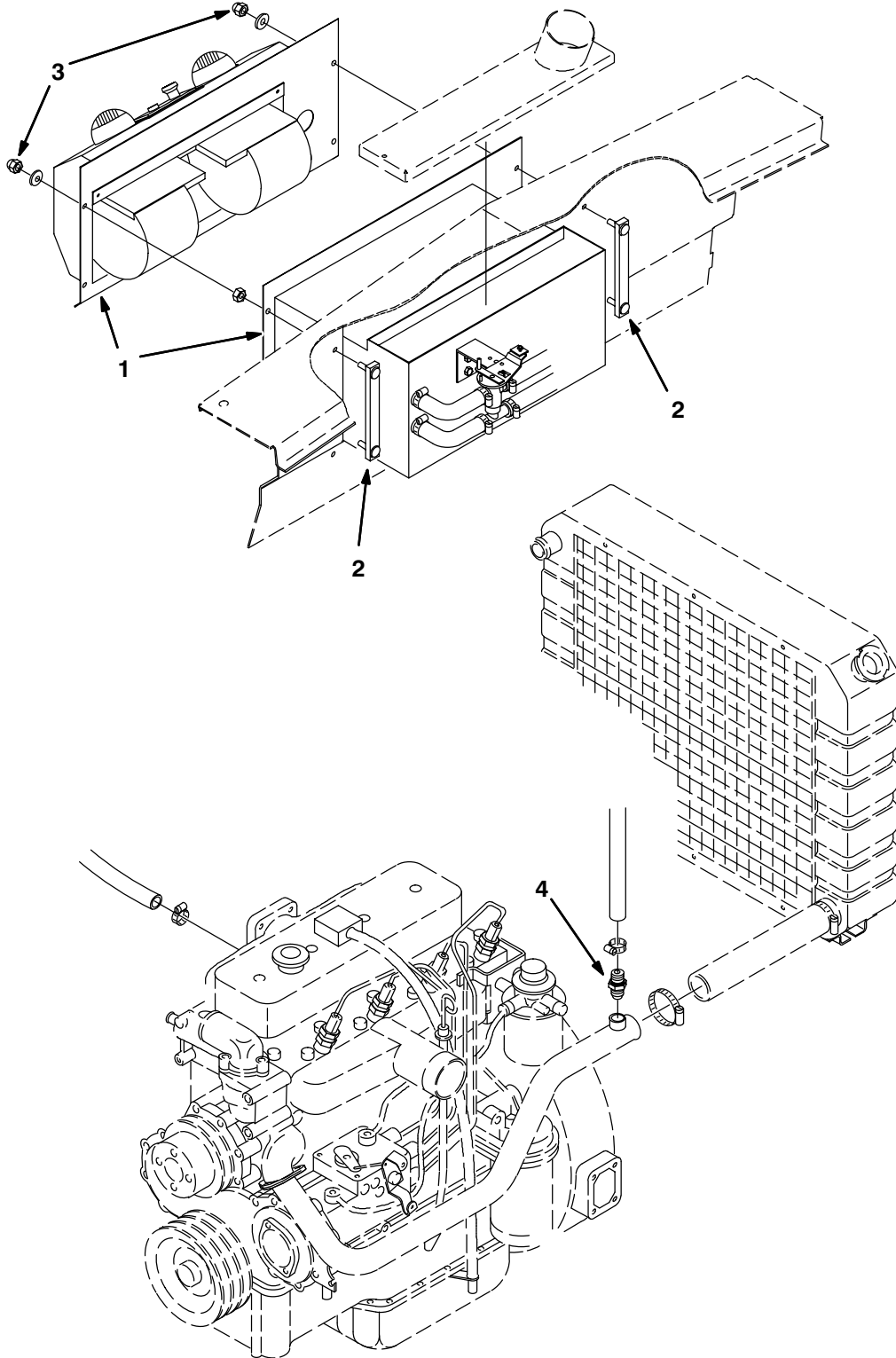

Fig. 32 – Heater/Pressurizer Assembly

Ref.	Tennant Part No.	Machine Serial Number	Description	Qty.
∇	76245	(000000–) Heater/Pressurizer Assy	1
1	74091	(000000–001397) Heater, Pressurizer Grp (Repl. By 21271) (See Break-downs)	1
1	21271	(001398–) Heater, Pressurizer Group (See Breakdowns)	1
2	75884	(000000–) Strip	2
3	41128	(000000–) Nut–Low Crown .31–18 Pltd	4
	76437	(000000–) Wire Harness	1
4	27767	(000000–) Fitting, Brass Str	1

Fig. 33 – Alternator Group, SE

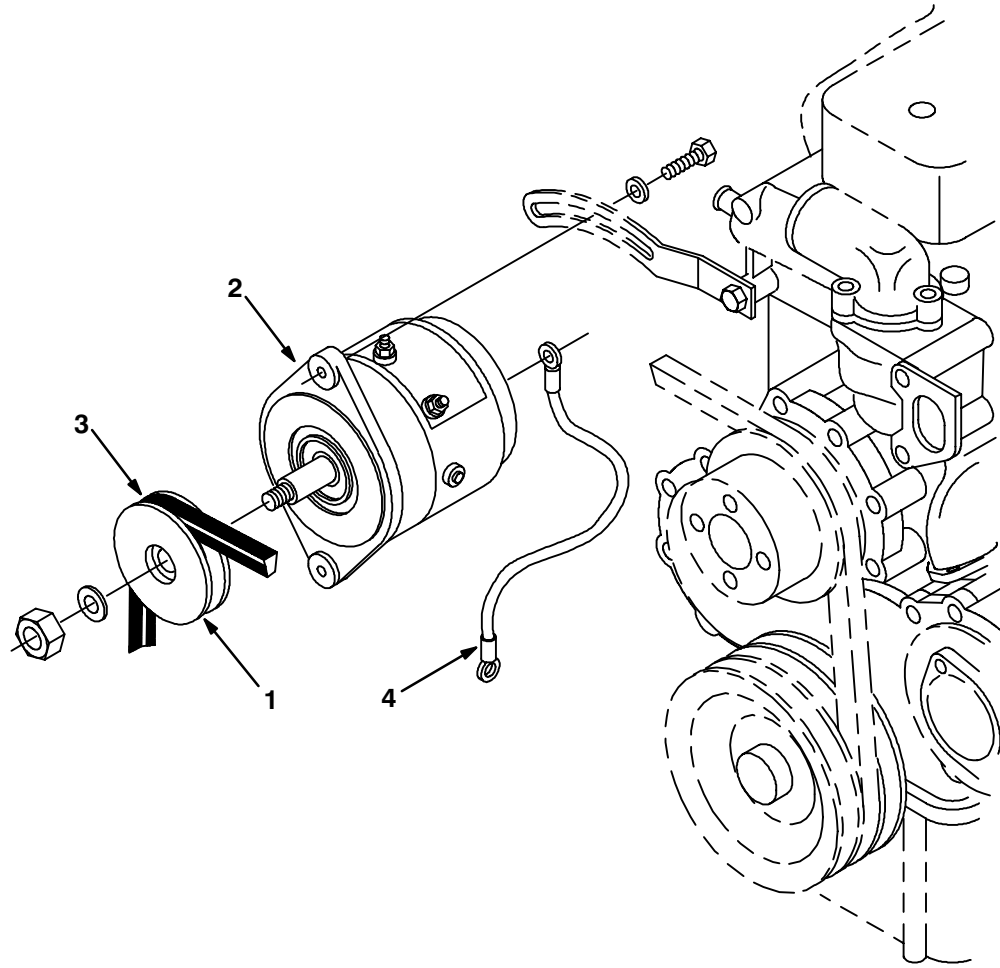

Fig. 33 – Alternator Group, SE

Ref.	Tennant Part No.	Machine Serial Number	Description	Qty.
1	77555	(000000–) Sheave, Alternator, Se	1
2	75828	(000000–) Alternator	1
3	60714	(000000–) V–Belt .47 42.50Lg	1
4	31525	(000000–) Wire, Ground, Alternator	1
	65222	(000000–) Sender, Filter, Hydraulic	1

Fig. 34 – Vacuum Wand Kit

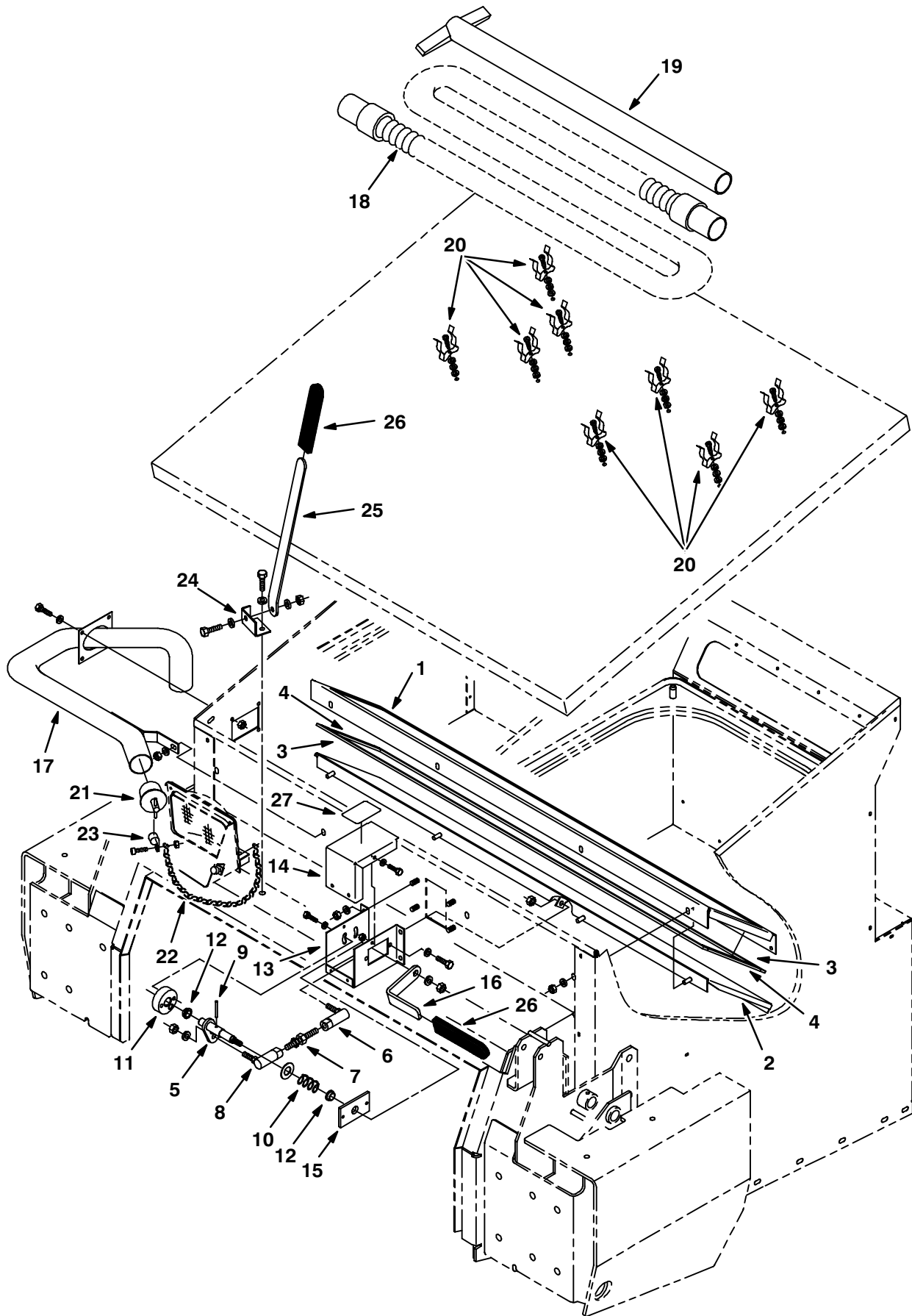

Fig. 34 – Vacuum Wand Kit

Ref.	Tennant Part No.	Machine Serial Number	Description	Qty.
▽	70668	(000000-001247)	Wand Kit, Vacuum	1
1	73871	(000000-001247)	Plate, Mounting, Vac Door	1
2	75701	(000000-001247)	Plate Wldt, Vac Door	1
3	75876	(000000-001247)	Seal, Foam Rbr, .19 .75W 47.1L	2
4	75877	(000000-001247)	Seal, Foam Rbr .19 .75W 8.43L	2
5	74083	(000000-001247)	Shaft Wldt	1
6	82962	(000000-001247)	Balljoint .375-24 Lh	1
7	11676	(000000-001247)	Stud, Adjustment	1
8	51531	(000000-001247)	Ball Joint .375-24	1
9	23146	(000000-001247)	Pin,Roll,.18Odx1.62L,.187/.192	1
10	19035	(000000-001247)	Sprng,Comp,0.83ldx.07Wire 1.0L	1
11	73884	(000000-001247)	Disk, Adjusting	1
12	04843	(000000-001247)	Bearing, Flange .625 Bore	2
13	73877	(000000-001247)	Panel, Cover	1
14	73878	(000000-001247)	Panel, Cover	1
15	73880	(000000-001247)	Plate	1
16	73883	(000000-001247)	Handle	1
17	74074	(000000-001247)	Adaptor Wldt, Vac Wand	1
18	54009	(000000-001247)	Hose&2Cuff Assy,Vinyl2.0ld10Ft	1
19	54012	(000000-001247)	Wand	1
20	36158	(000000-001247)	Clip Finger Grip	8
21	42124	(000000-001247)	Plug, Drain	1
22	01570	(000000-001247)	Chain,#12Jack Type 6.0Lg	1
23	26395-2	(000000-001247)	Clamp-Cable, 0.38Dia 0.38Wth	1
24	76286	(000000-001247)	Adaptor Wldt, Vac Wand	1
25	76338	(000000-001247)	Bar, Prop	1
26	70659	(000000-001247)	Grip, Handle, Flat	2
27	76406	(000000-001247)	Label, Vac Wand	1

Fig. 35 – Vacuum Wand Kit

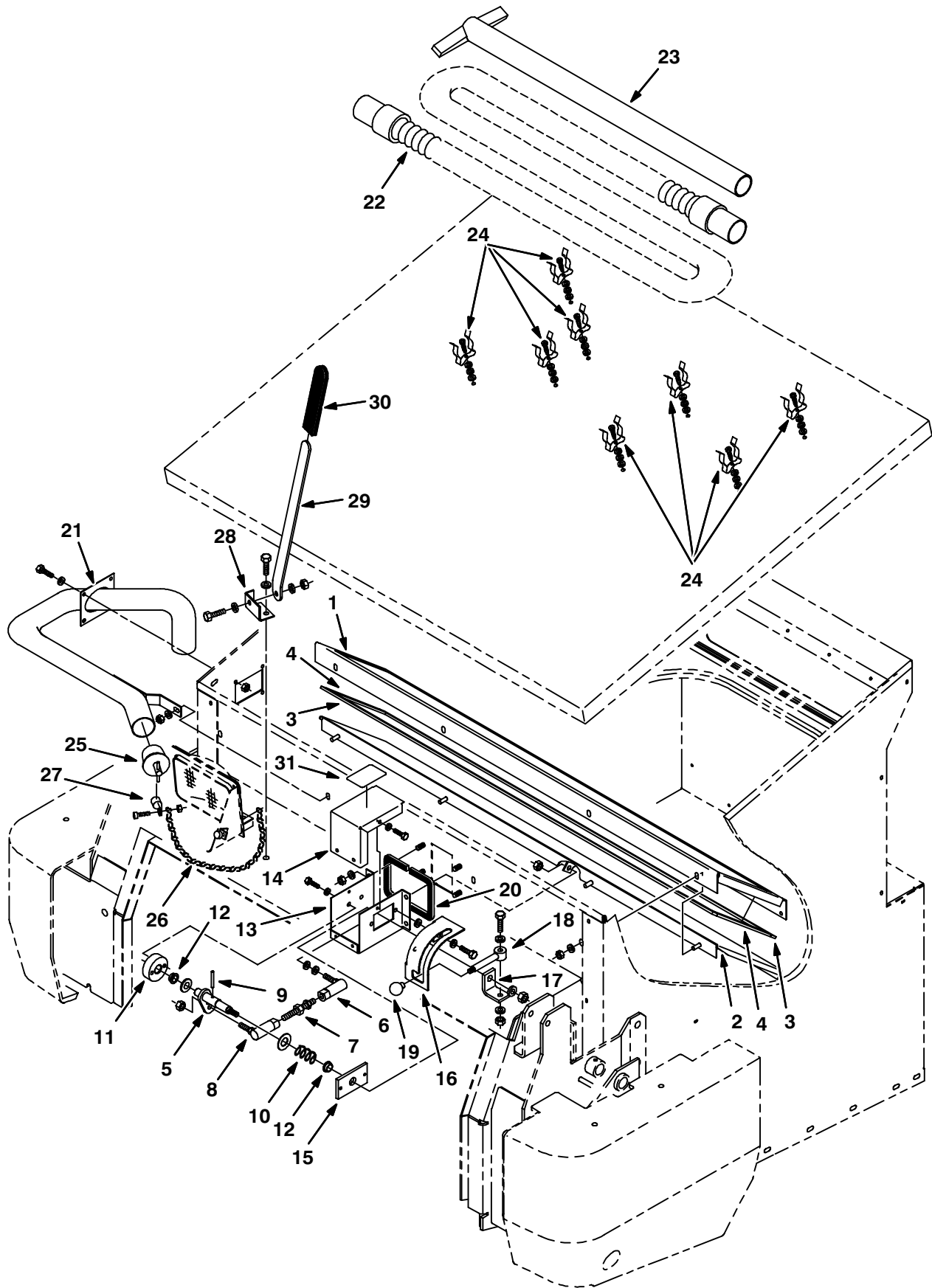

Fig. 35 – Vacuum Wand Kit

Ref.	Tennant Part No.	Machine Serial Number	Description	Qty.
▽	70668	(001248–)	Wand Kit, Vac	1
1	73871	(001248–)	Plate, Mounting, Vac Door	1
2	75701	(001248–)	Plate Wldt, Vac Door	1
3	75876	(001248–)	Seal, Foam Rbr, .19 .75W 47.1L	2
4	75877	(001248–)	Seal, Foam Rbr .19 .75W 8.43L	2
5	21047	(001248–)	Shaft	1
6	82962	(001248–)	Balljoint .375–24 Lh	1
7	11676	(001248–)	Stud, Adjustment	1
8	51531	(001248–)	Ball Joint .375–24	1
9	23146	(001248–)	Pin,Roll,.18Odx1.62L,.187/.192	1
10	19035	(001248–)	Sprng,Comp,0.83ldx.07Wire 1.0L	1
11	21041	(001248–)	Disk	1
12	04843	(001248–)	Bearing, Flange .625 Bore	2
13	21054	(001248–)	Box, Mounting, Lever, Vac	1
14	21104	(001248–)	Panel, Cover	1
15	73880	(001248–)	Plate	1
16	79646	(001248–)	Plate, Latch	1
17	79647	(001248–)	Angle	1
18	79644	(001248–)	Handle	1
19	26565	(001248–)	Knob,0.38–16,1.25Dia,Plastic	1
20	79674	(001248–)	Seal	1
21	74074	(001248–)	Adaptor Wldt, Vac Wand	1
22	54009	(001248–)	Hose&2Cuff Assy,Vinyl2.0ld10Ft	1
23	54012	(001248–)	Wand	1
24	36158	(001248–)	Clip Finger Grip	8
25	42124	(001248–)	Plug, Drain	1
26	01570	(001248–)	Chain,#12Jack Type 6.0Lg	1
27	26395–2	(001248–)	Clamp–Cable, 0.38Dia 0.38Wth	1
28	76286	(001248–)	Adaptor Wldt, Vac Wand	1
29	76338	(001248–)	Bar, Prop	1
30	70659	(001248–)	Grip, Handle, Flat	2
31	76406	(001248–)	Label, Vac Wand	1

Fig. 36 – Side Brush Dust Control Kit

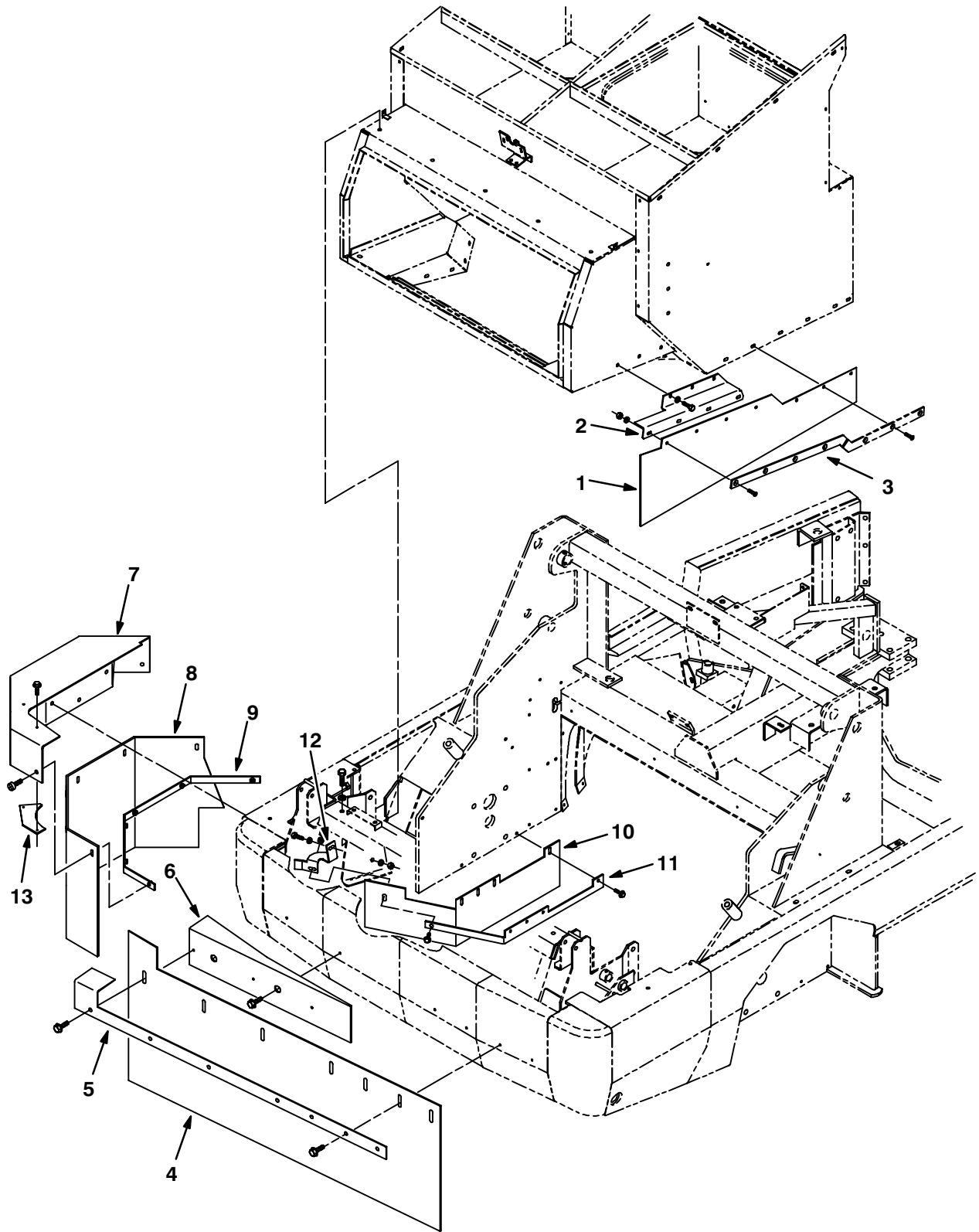

Fig. 36 – Side Brush Dust Control Kit

Ref.	Tennant Part No.	Machine Serial Number	Description	Qty.
∇	76100	(000000–)	Dust Control Kit, Side Brush	1
1	76036	(000000–)	Skirt, Deflection	1
2	76030	(000000–)	Bracket, Mounting, Skirt	1
3	76038	(000000–)	Strip, Retainer, Skirt	1
4	75901	(000000–)	Skirt, Cover, Sbdc	1
5	76049	(000000–)	Skirt, Retainer	1
6	77759	(000000–)	Bracket Wldt	1
7	75989	(000000–)	Plate Wldt, Skirt	1
8	76069	(000000–)	Skirt, Cover, Sbdc	1
9	76055	(000000–)	Plate, Retainer	1
10	76074	(000000–)	Skirt	1
11	76081	(000000–)	Skirt	1
12	76084	(000000–)	Bracket	1
13	77755	(000000–)	Plate	1

Fig. 37 – Air Cleaner Assembly, Die SE

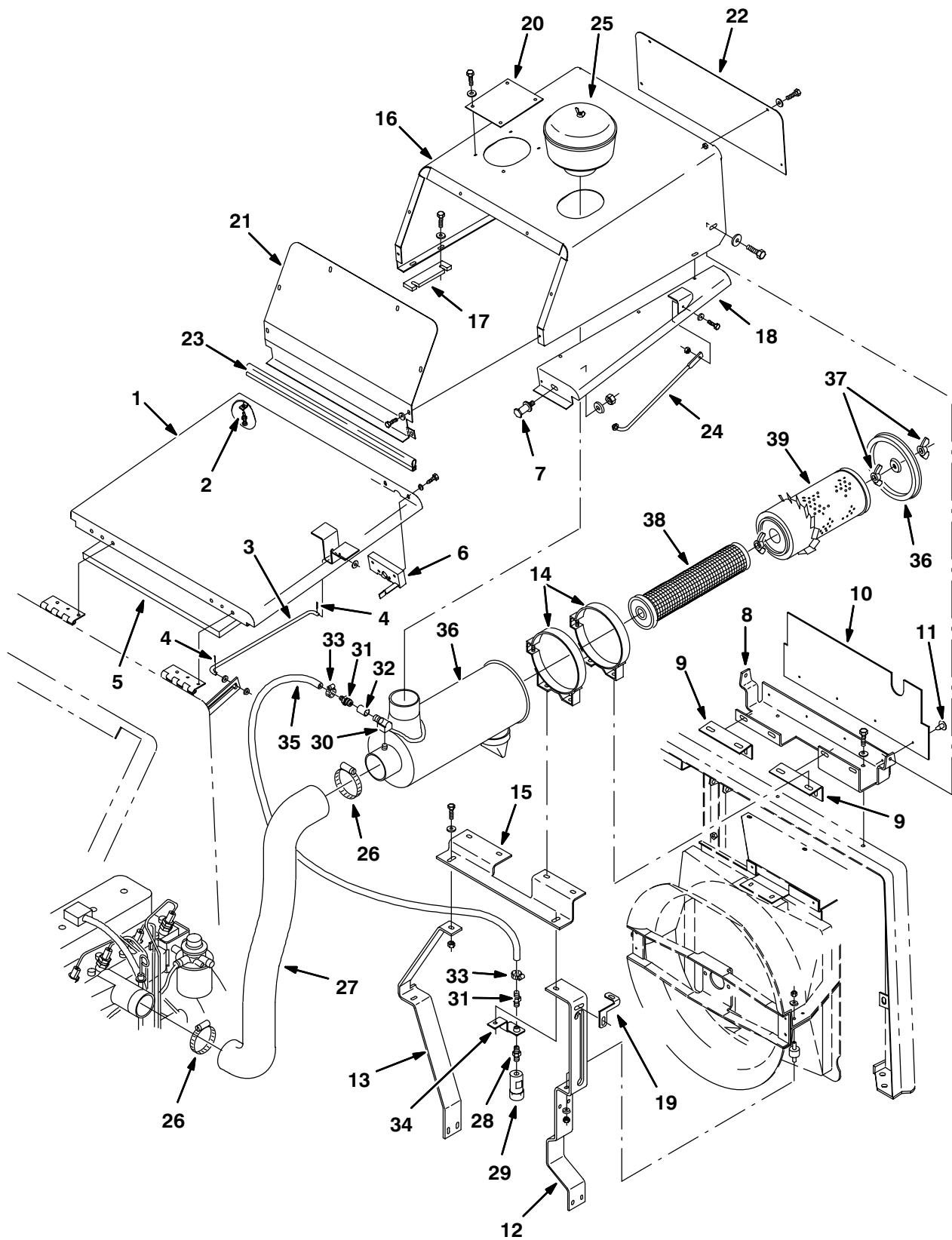
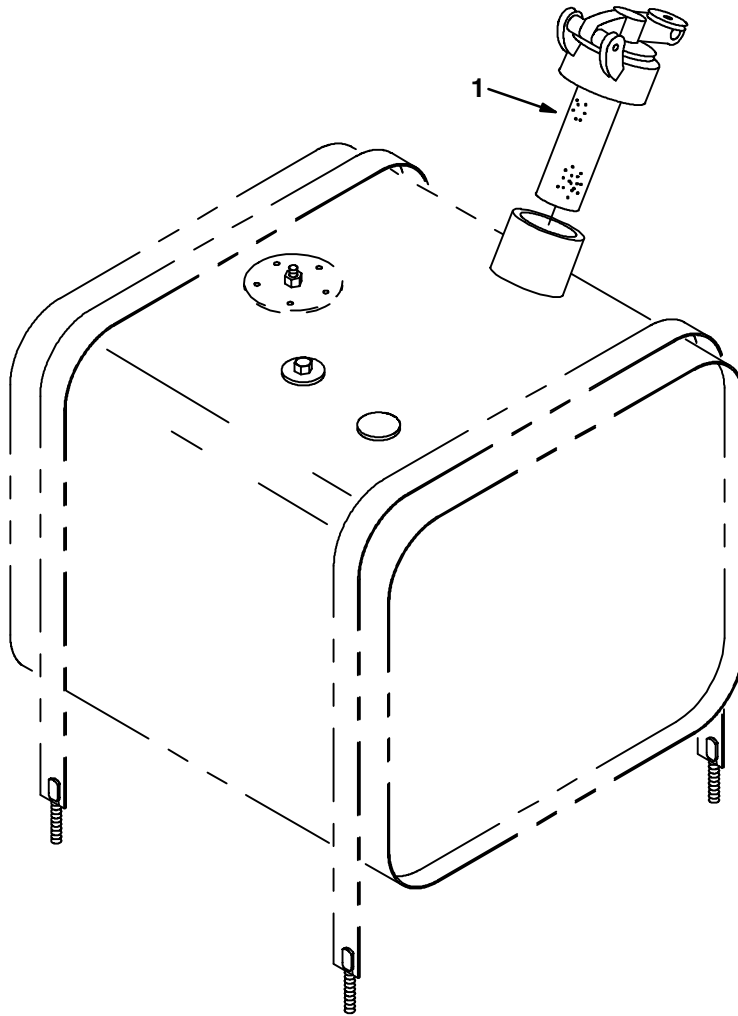

Fig. 37 – Air Cleaner Assembly, Die SE

Ref.	Tennant Part No.	Machine Serial Number	Description	Qty.
1	75303	(000000–)	Cover Wldt, Engine Se	1
2	75128	(000000–)	Spindle, Adjustment	1
3	75883	(000000–)	Rod Support, Cover	1
4	39005	(000000–)	Pin– Cotter .094X0.75	2
5	76870	(000000–)	Insulation,S/Foam .8X19.3X20.3	1
6	58844	(000000–)	Latch, Hook, Lh	1
7	59192	(000000–)	Latch, Bolt	1
8	77703	(000000–)	Channel, Hinge, Filter Cover	1
9	79620	(000000–)	Bracket, Rear, Se	2
10	79626	(000000–)	Skirt, Air Cleaner, Se	1
11	72968	(000000–)	Rivet, Plastic .250X.898	4
12	77706	(000000–)	Bracket, Front, Lh	1
13	77707	(000000–)	Bracket, Front, Rh	1
14	76321	(000000–)	Band,Mtg.	2
15	77704	(000000–)	Bracket, Mounting, Filter, Fro	1
16	77710	(000000–)	Panel, Cover, A/C Filter	1
17	21230	(000000–)	Plate, Support, Cover Se	1
18	77712	(000000–)	Panel Wldt, Cover	1
19	79624	(000000–)	Bracket	1
20	79625	(000000–)	Plate	1
21	77708	(000000–)	Panel, Cover, Front A/C	1
22	77489	(000000–)	Panel, Cover, Rear, A/C Filter	1
23	77778	(000000–)	Seal, Bulb, Sd–0504 19.75Lg	1
24	54615	(000000–)	Rod, Seat	1
25	75666	(000000–)	Filter, Pre–Cleaner, A/C	1
26	43555	(000000–)	Clamp–Wormdrive, 1.62– 3.50D	2
27	77765	(000000–)	Hose, Molded, Se, Diesel	1
28	51560–5	(000000–)	Adaptor, Filter, 1/8 Npt	1
29	03026	(000000–)	Indicator Service Air Filter	1
30	11984	(000000–)	Ftg, EI90 Npt/02Pf–02Pm	1
31	27768	(000000–)	Fitting, Brass Em06/Pm02	2
32	11848	(000000–)	Ftg,Pipe,Cplg.Full 0.13Pt.Blk	1
33	43844	(000000–)	Clamp–Wormdrive, 0.25– 0.62D	2
34	77773	(000000–)	Bracket Wldt	1
35	70876	(000000–)	Hose, Rubber.38Idx.62Od 21.0Lg	1
∇	35424	(000000–)	Air Cleaner	1
	07562	(000000–)	Nut,Wing .44–20 Special	2
	60933	(000000–)	Element, Filter Safety	1
	60934	(000000–)	Element, Air Cleaner	1

Fig. 38 – Protectoseal Fuel Tank Cap Group



07867/07471

Ref.	Tennant Part No.	Machine Serial Number	Description	Qty.
1	02506-6	(000000-)	Gas Cap, Protectoseal	1

Fig. 39 – Fire Extinguisher Kit

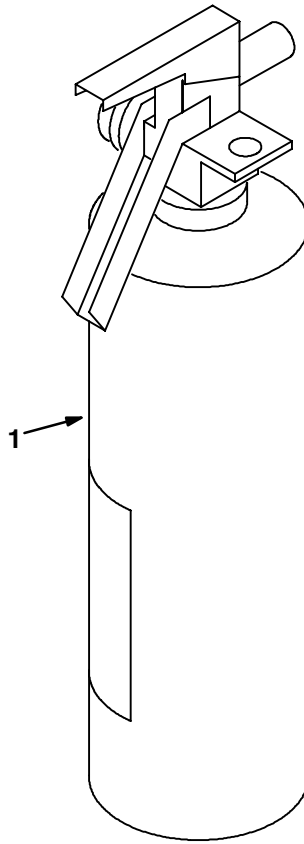

07687/07516

Ref.	Tennant Part No.	Machine Serial Number	Description	Qty.
∇	70692	(000000–) Extinguisher Kit Fire 800	1
1	25312	(000000–) Extinguisher, Fire	

Fig. 40 – Solid Tire and Rim Assembly, Front

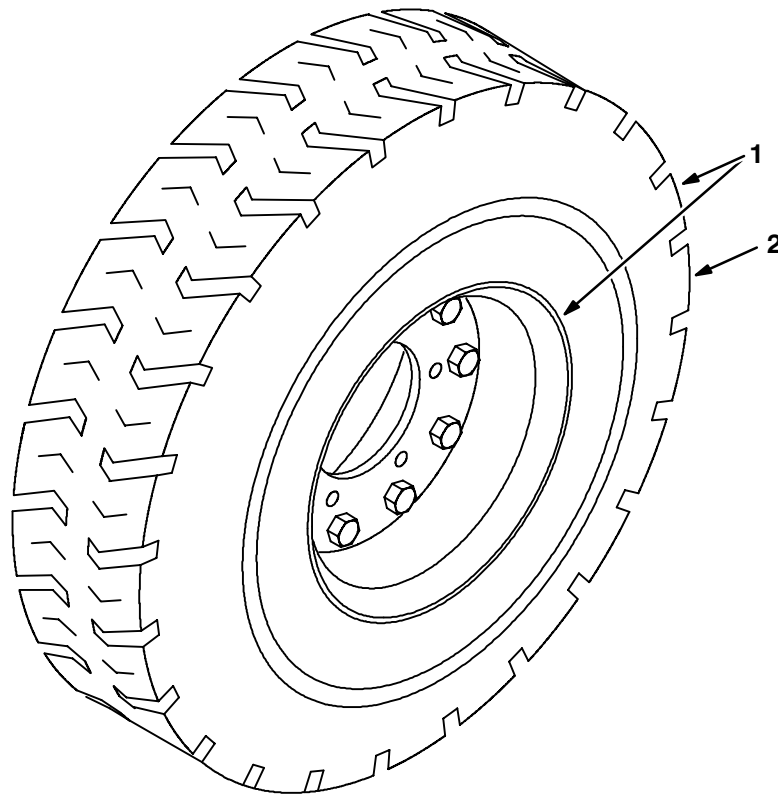

07665/07666

	Ref.	Tennant Part No.	Machine Serial Number	Description	Qty.
∇	1	63226	(000000–)	Tire and Rim Assembly, Solid 6.50–10	1
	2	63228	(000000–)	Tire, Solid	1

Fig. 41 – Solid Tire and Rim Assembly, Rear

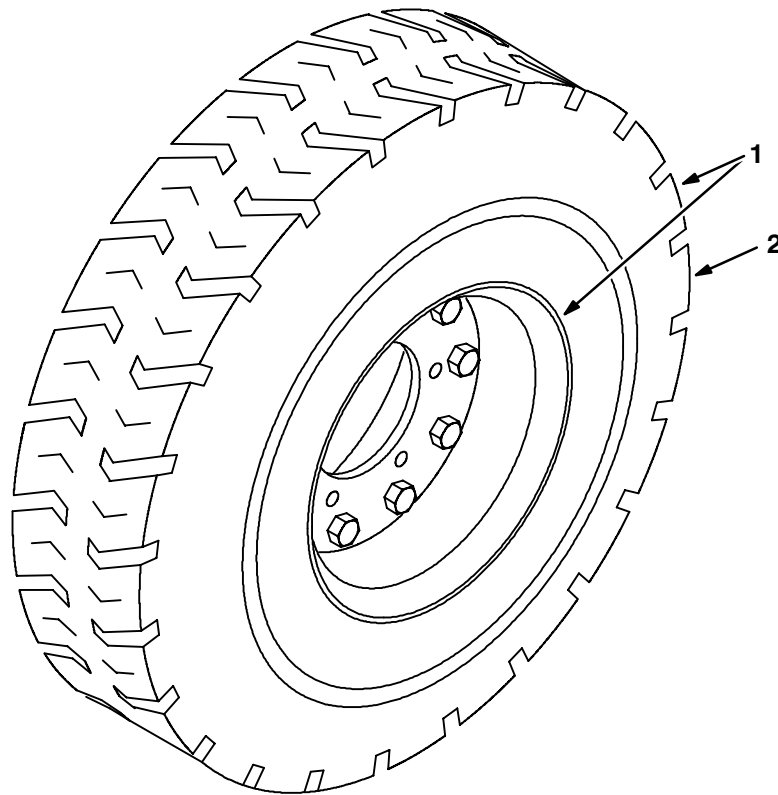

10504/07666

Ref.	Tennant Part No.	Machine Serial Number	Description	Qty.
∇ 1	21671	(000000–)	Tire and Rim Assy, Rear, Solid 6.5	1
2	63228	(000000–)	Tire, Solid	1

Fig. 42 – Seat Belt Kit

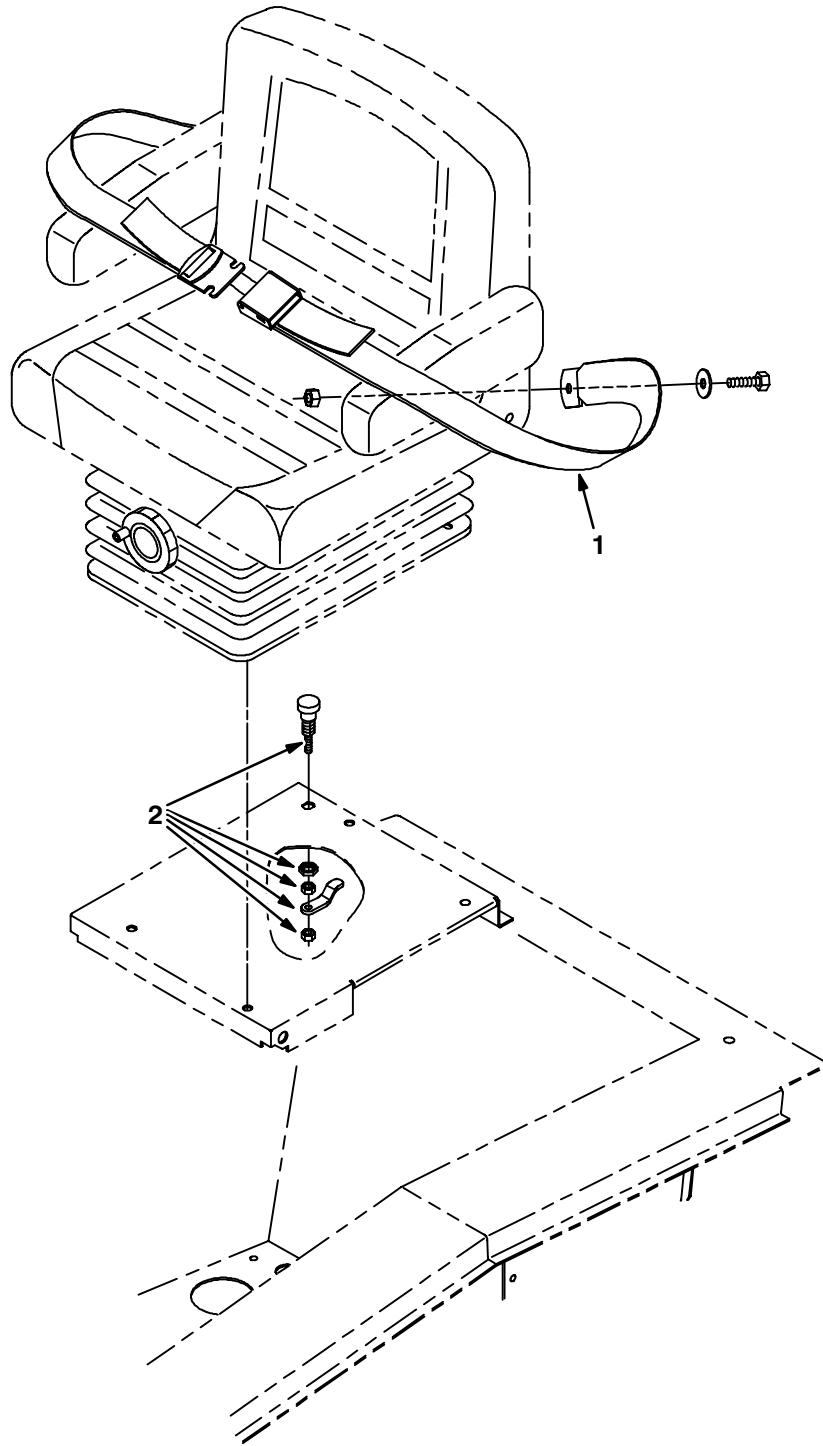

07673/07674

Ref.	Tennant Part No.	Machine Serial Number	Description	Qty.
∇	70690	(000000–)	Seat Belt Kit	1
1	30533	(000000–)	Belt, Seat	1
2	87337	(000000–)	Latch, Door	1

Fig. 43 – Neutral Start Group

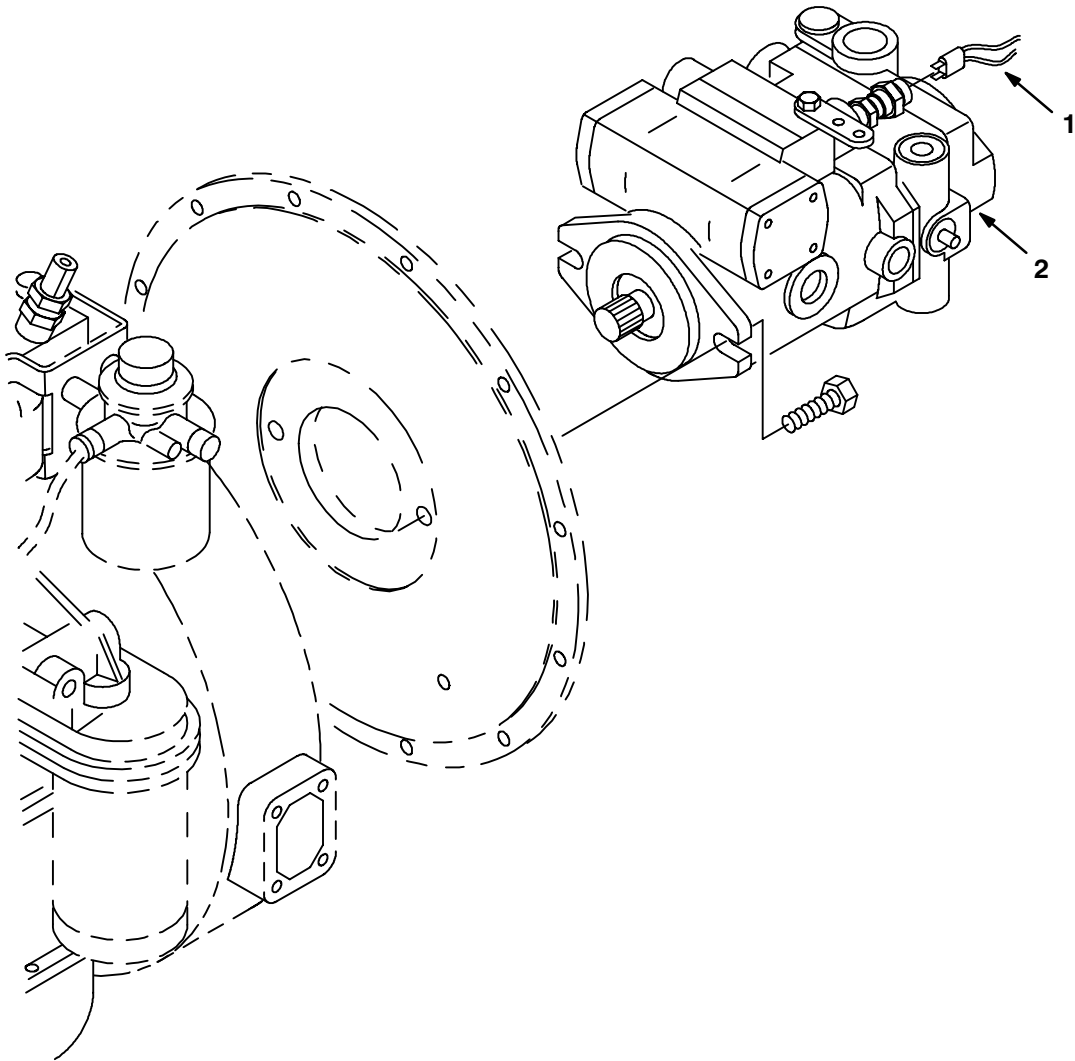

09830/09831

Ref.	Tennant Part No.	Machine Serial Number	Description	Qty.
1	63407	(000000–)	Harness, Neutral, Start	1
2	74164	(000000–)	Pump, Hyd Piston V 2.48 (see breakdowns)	1

Fig. 44 – RFS Filter System Group

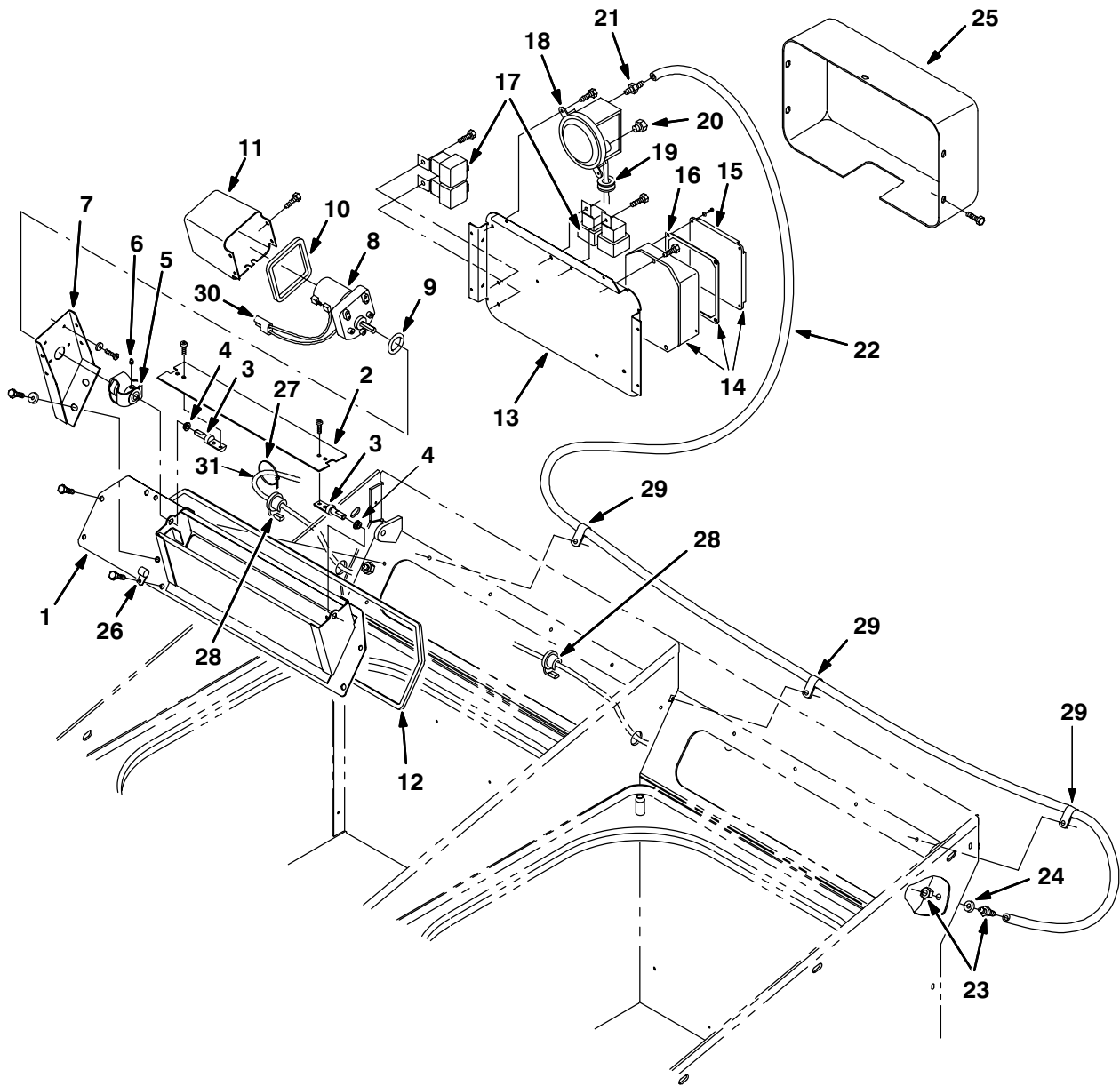
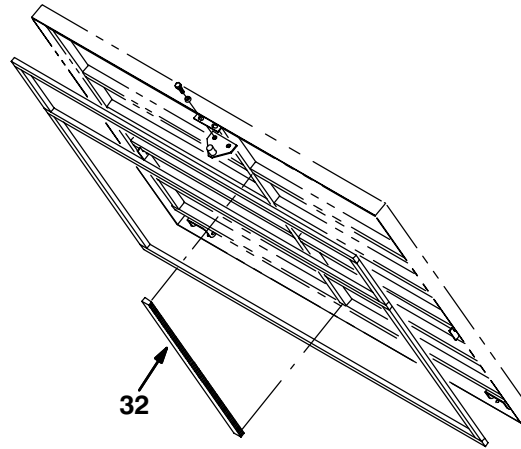

Fig. 44 – RFS Filter System Group



10230/10229,10232

Ref.	Tennant Part No.	Machine Serial Number	Description	Qty.	
▽	79174	(000000–) Rfs Kit	1	
1	79160	(000000–) Duct Wldt, Rfs	2	
2	79156	(000000–) Plate, Shutter	2	
3	79159	(000000–) Shaft, Pivot	4	
4	11747	(000000–) Bearing, Nylon	4	
5	79158	(000000–) Coupling	2	
6	20634	(000000–) Scr–Set 10–24X0.25 Nylon Loc	4	
7	79157	(000000–) Bracket, Mounting, Gearmotor	2	
8	79170	(000000–) Motor, Ele, Geared, 12Vdc	2	
9	79172	(000000–) Seal, O–Ring .787ldx.210Th	2	
10	79167	(000000–) Seal	2	
11	79155	(000000–) Cover, Motor	2	
12	79168	(000000–) Seal	2	
13	79177	(000000–) Plate, Mounting, Rfs Control	1	
▽	14	79176	(000000–) Controller Assy, Rfs	1
15	59954	(000000–) Cover, Housing, Electrical	1	
16	59921	(000000–) Gasket, Cover, Alum	1	
17	56186	(000000–) Relay, Shrouded, 12 Vdc	4	
18	75465	(000000–) Switch, Pressure	1	
19	10632–4	(000000–) Grommet,Rbr,0.62ld,For .06Matl	1	
20	82739	(000000–) Ftg, Breather	1	
21	40607	(000000–) Ftg,Brass,St Bm03/Pm02	1	
22	21301	(000000–) Hose, Vacuum, .16 ld X 76.0 Lg	1	
23	39923	(000000–) Ftg,Bulkhead–Barb Wh 1074X4	1	
24	43454	(000000–) Washer, .344B .69D .06Nylon	1	
25	79169	(000000–) Cover, Electrical	1	
26	40678	(000000–) Clamp,Cable .44D .62Wide	2	
27	49266	(000000–) Tie, Cable 1.75D Max 7.50Lg	12	
28	34864	(000000–) Strain,Relief	2	
29	46236	(000000–) Clamp–Cable, 0.25Dia 0.56Wth	3	
30	79025	(000000–) Harness, Motor, Duct	2	
31	79026	(000000–) Harness, Hopper, Rfs	1	
	83706	(000000–) Harness, Rfs Jumper	1	
32	70851	(000000–) Seal, Urethane	1	
	44961	(000000–) Tie, Cable 4.00 Max 14.50Lg	14	

Fig. 45 – Documentation Group

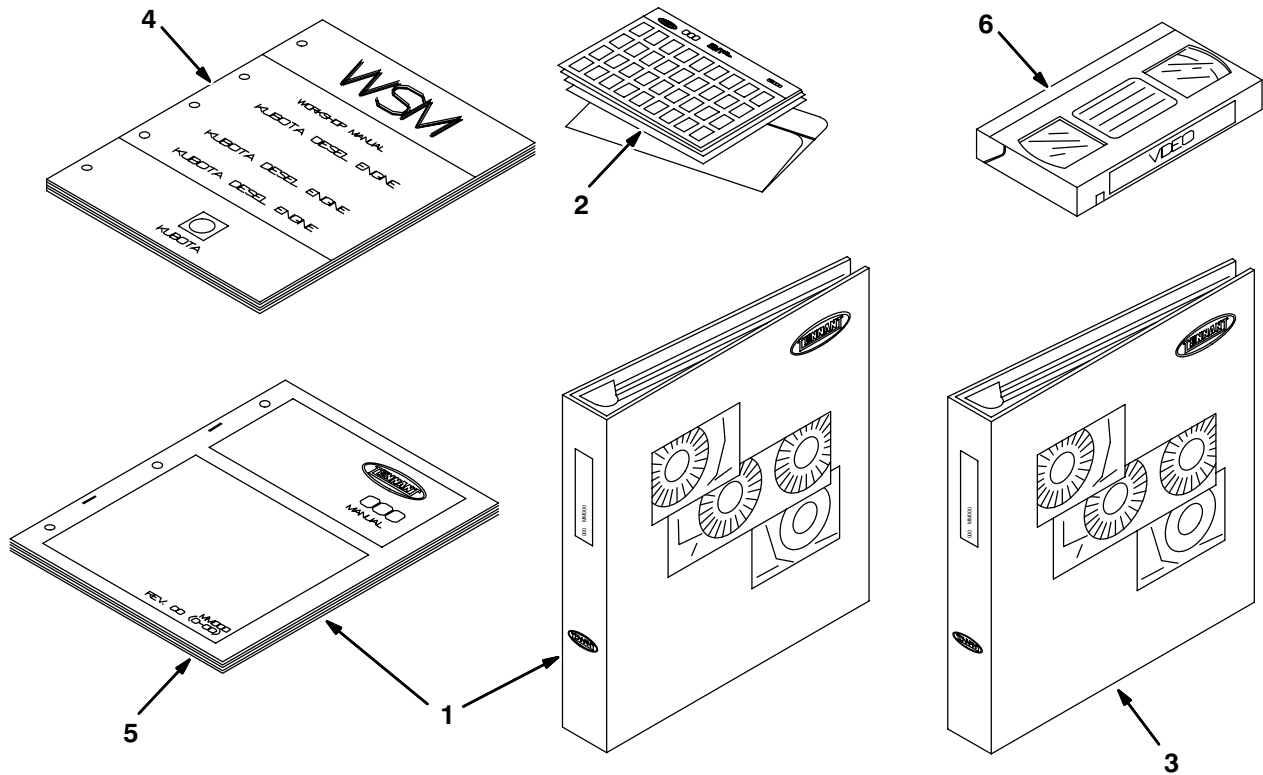

07680/07501

Ref.	Tennant Part No.	Machine Serial Number	Description	Qty.
1	MM308	(000000–)	Manual Pkg 800D	1
2	85308	(000000–)	Manual-Fiche Pkg 800D	1
3	MM337	(000000–)	Manual, Service 800/810	1
4	61838	(000000–)	Engine Service Manual PK(200 Series)	1
5	MM308ES	(000000–)	Manual Op/Mt 800D Spanish	1
5	MM308FR	(000000–)	Manual Op/Mt 800D French	1
6	48842	(000000–)	Oper/Video Vhs, 800	1

SECTION 4

CONTENTS

	PAGE
Fig. 1 – Hydraulic Piston Pump Breakdown, 62548	4-2
Fig. 2 – Hydraulic Piston Pump Breakdown, 62548	4-4
Fig. 3 – Hydraulic Piston Pump Breakdown, 74163	4-6
Fig. 4 – Hydraulic Piston Pump Breakdown, 74163	4-8
Fig. 5 – Hydraulic Piston Pump Breakdown, 65219	4-10
Fig. 6 – Hydraulic Piston Pump Breakdown, 65219	4-12
Fig. 7 – Hydraulic Piston Pump Breakdown, 74164	4-14
Fig. 8 – Hydraulic Piston Pump Breakdown, 74164	4-16
Fig. 9 – Hydraulic Gear Pump Breakdown, 62561	4-18
Fig. 10 – Hydraulic Motor Breakdown, 63426	4-19
Fig. 11 – Hydraulic Motor Breakdown, 53434	4-20
Fig. 12 – Hydraulic Motor Breakdown, 62564	4-21
Fig. 13 – Hydraulic Motor Breakdown, 79781	4-22
Fig. 14 – Hydraulic Motor Breakdown, 19117	4-23
Fig. 15 – Hydraulic Motor Breakdown, 63542	4-24
Fig. 16 – Hydraulic Steering Valve Breakdown, 62565	4-25
Fig. 17 – Hydraulic Steering Valve Breakdown, 65242	4-26
Fig. 18 – Hydraulic Solenoid Valve Breakdown, 65391	4-27
Fig. 19 – Hydraulic Solenoid Valve Breakdown, 84015	4-28
Fig. 20 – Hydraulic Solenoid Valve Breakdown, 84016	4-29
Fig. 21 – Hydraulic Solenoid Valve Breakdown, 63527	4-30
Fig. 22 – Hydraulic Solenoid Valve Breakdown, 78996	4-32
Fig. 23 – Hydraulic Solenoid Valve Breakdown, 84014	4-34
Fig. 24 – Hydraulic Valve Breakdown, 62567	4-36
Fig. 25 – Hydraulic Valve Breakdown, 77495	4-37
Fig. 26 – Hydraulic Manual Control Breakdown, 74285	4-38
Fig. 27 – Hydraulic Manual Control Breakdown, 74273	4-40
Fig. 28 – Hydraulic Cylinder Breakdown, 53601	4-42
Fig. 29 – Hydraulic Cylinder Breakdown, 62975	4-43
Fig. 30 – Air Conditioner Breakdown, 77675	4-44
Fig. 31 – Air Conditioner Breakdown, 21270	4-46
Fig. 32 – Heater/Pressurizer Breakdown, 74091	4-48
Fig. 33 – Heater/Pressurizer Breakdown, 21271	4-50

Fig. 1 – Hydraulic Piston Pump Breakdown, 62548

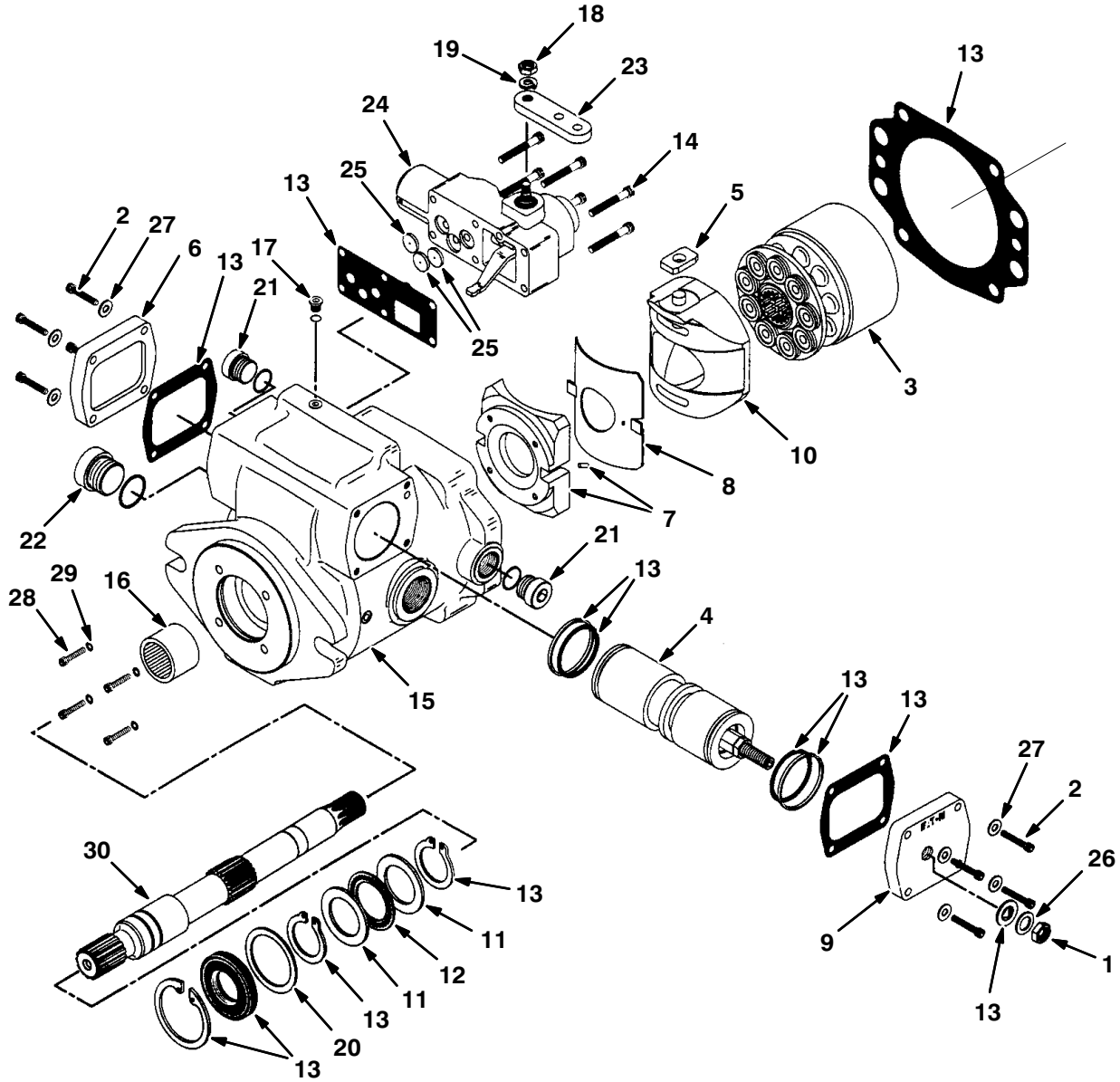

Fig. 1 – Hydraulic Piston Pump Breakdown, 62548

NOTE: Piston Pump, TENNANT Part Number 62548, includes Fig. 1, and Fig. 2.

Ref.	Tennant Part No.	Machine Serial Number	Description	Qty.
∇	62548	(000000–)	Pump–Hyd Piston V 2.48 R4500	1
1	74184	(000000–)	Nut, Jam	1
2	74223	(000000–)	Screw, Cap	8
3	61882	(000000–)	Rotating Kit	1
4	74286	(000000–)	Servo Piston Sa En	1
5	74287	(000000–)	Follower,Piston En	1
6	74256	(000000–)	Plate, Cover En	1
7	74288	(000000–)	Camplate Cradle En	1
8	74289	(000000–)	Cam Bushing En	1
9	74257	(000000–)	Plate, Cover En	1
10	74224	(000000–)	Camplate S/A En	1
11	74240	(000000–)	Race, Bearing Ce	2
12	74210	(000000–)	Bearing	1
13	79709	(000000–)	Seal Kit, Pump En	1
14	74262	(000000–)	Screw, Cap En	6
∇	15 79703	(000000–)	Housing S/A En	1
16	37462	(000000–)	Bearing	1
17	79742	(000000–)	Plug S/A En	1
18	74266	(000000–)	Nut En	1
19	74267	(000000–)	Lockwasher En	1
20	37460	(000000–)	Washer	1
21	13907	(000000–)	Plug #8	2
22	79779	(000000–)	Plug,#12 O–Ring Ph	1
23	74272	(000000–)	Arm, Control En	1
24	74273	(000000–)	Control, Manual (see Breakdown)	1
25	74276	(000000–)	Orifice, Valve En	3
26	74280	(000000–)	Washer En	1
27	74281	(000000–)	Washer En	8
28	79706	(000000–)	Screw, Cap En	4
29	79707	(000000–)	Washer En	4
30	74265	(000000–)	Shaft, Drive Sp En	1

Fig. 2 – Hydraulic Piston Pump Breakdown, 62548

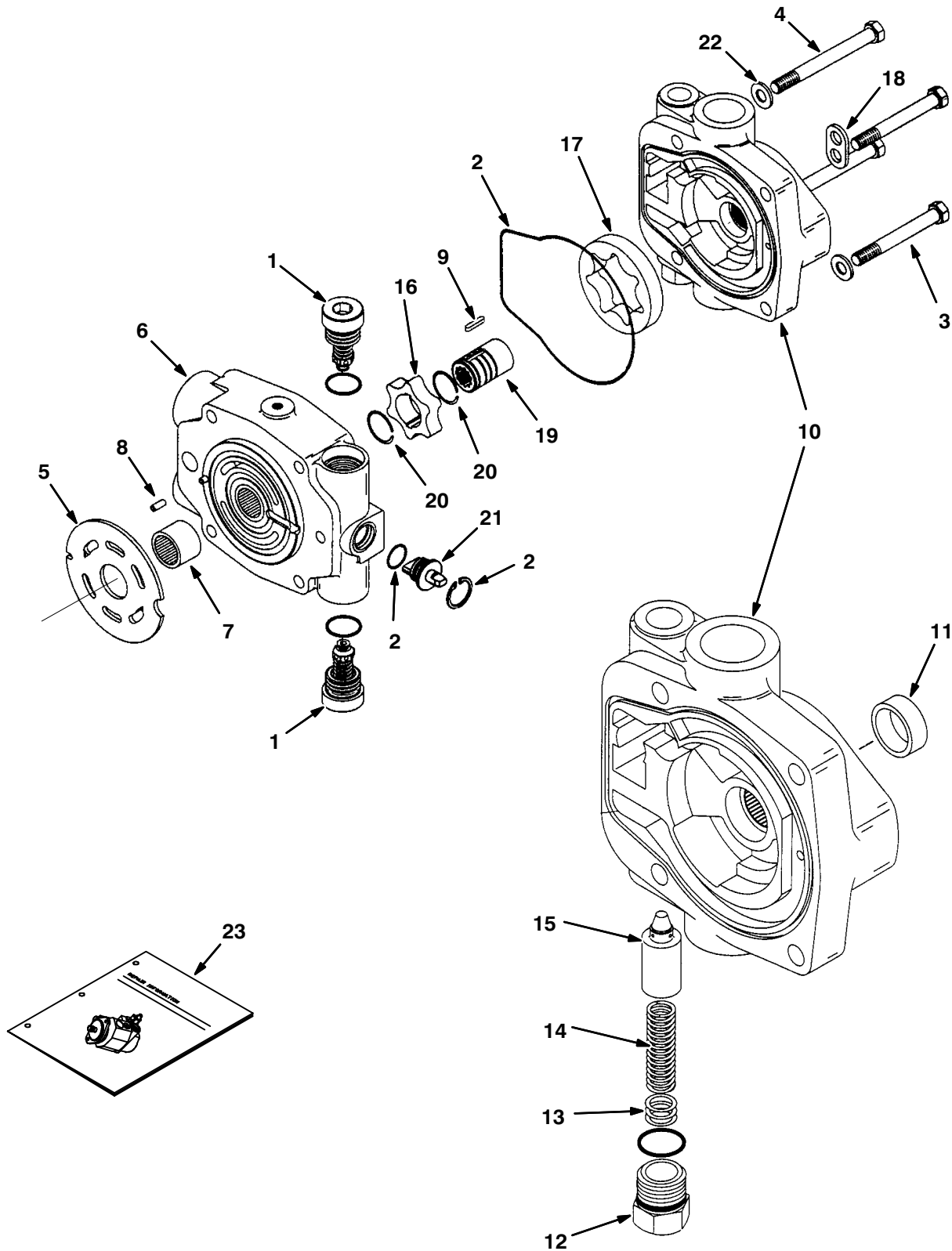

Fig. 2 – Hydraulic Piston Pump Breakdown, 62548

NOTE: Piston Pump, TENNANT Part Number 62548, includes Fig. 1, and Fig. 2.

Ref.	Tennant Part No.	Machine Serial Number	Description	Qty.
∇	62548	(000000–)	Pump–Hyd Piston V 2.48 R4500	1
1	74259	(000000–)	Relief Valve Sa En	2
2	79709	(000000–)	Seal Kit, Pump En	1
3	74260	(000000–)	Screw, Cap En	2
4	74261	(000000–)	Screw, Cap En	2
5	61886	(000000–)	Valve Plate	1
∇	6	79704	(000000–) Backplate S/A En	1
7	34159	(000000–)	Bearing	1
8	79748	(000000–)	Roll Pin En	1
9	74270	(000000–)	Key En	1
∇	10	74271	(000000–) Charge Pmp Adap En	1
11	79749	(000000–)	Bushing En	1
12	79750	(000000–)	Plug En	1
13	79751	(000000–)	Shims En	1
14	79752	(000000–)	Spring En	1
15	79753	(000000–)	Poppet En	1
16	74274	(000000–)	Geroter,Ring In En	1
17	74275	(000000–)	Geroter,Ring Ot En	1
18	79705	(000000–)	Strap, Shipping En	1
19	74277	(000000–)	Coupler En	1
20	74278	(000000–)	Ring, Retaining En	2
21	74279	(000000–)	Actuator, Valve En	1
22	74282	(000000–)	Washer En	4
23	74284	(000000–)	Repair Info,Pmp En	1

Fig. 3 – Hydraulic Piston Pump Breakdown, 74163

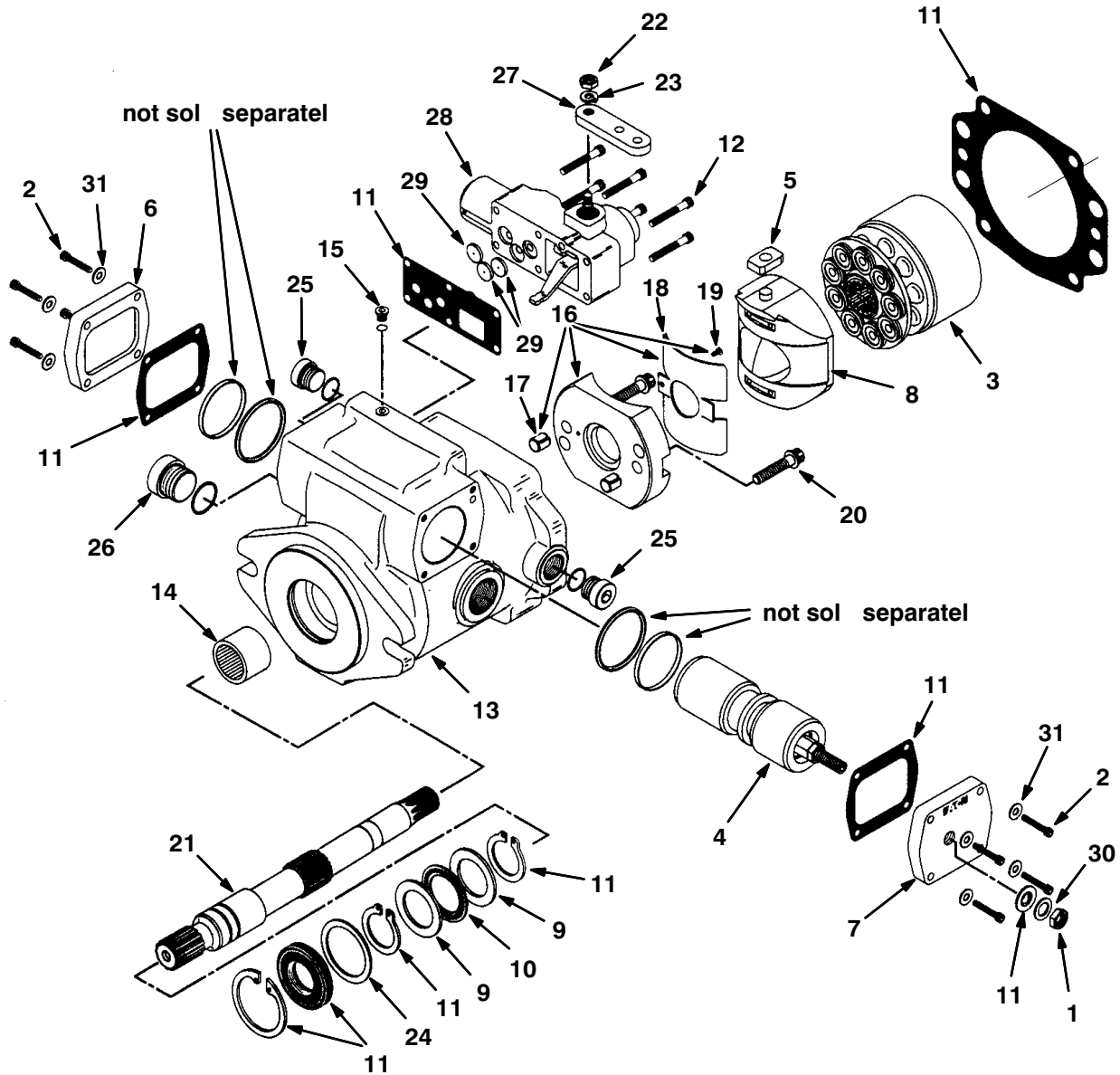

Fig. 3 – Hydraulic Piston Pump Breakdown, 74163

NOTE: Piston Pump, TENNANT Part Number 74163, includes Fig. 3, and Fig. 4.

Ref.	Tennant Part No.	Machine Serial Number	Description	Qty.
▽	74163	(000000–)	Pump, Hyd Piston V 2.48 R4500	1
1	74184	(000000–)	Nut, Jam	1
2	74223	(000000–)	Screw, Cap	8
3	61882	(000000–)	Rotating Kit	1
4	74253	(000000–)	Piston, Servo	1
5	74254	(000000–)	Follower, Piston	1
6	74256	(000000–)	Plate, Cover En	1
7	74257	(000000–)	Plate, Cover En	1
8	74258	(000000–)	Camplate S/A En	1
9	74240	(000000–)	Race, Bearing Ce	2
10	74210	(000000–)	Bearing	1
11	74283	(000000–)	Seal Kit, Pump En	1
12	74262	(000000–)	Screw, Cap En	6
▽	74263	(000000–)	Housing S/A En	1
13	79771	(000000–)	Housing En	1
14	37462	(000000–)	Bearing	1
15	79742	(000000–)	Plug S/A En	1
▽	79743	(000000–)	Cradle Sub Assy En	1
17	79744	(000000–)	Dowel Bushing En	2
18	79745	(000000–)	Bushing En	1
19	79746	(000000–)	Cap Screw En	1
20	79747	(000000–)	Cap Screw En	2
21	74265	(000000–)	Shaft, Drive Sp En	1
22	74266	(000000–)	Nut En	1
23	74267	(000000–)	Lockwasher En	1
24	37460	(000000–)	Washer	1
25	13907	(000000–)	Plug #8	2
26	79779	(000000–)	Plug,#12 O–Ring Ph	1
27	74272	(000000–)	Arm, Control En	1
28	74273	(000000–)	Control, Manual (see Breakdown)	1
29	74276	(000000–)	Orifice, Valve En	1
30	74280	(000000–)	Washer En	1
31	74281	(000000–)	Washer En	8

Fig. 4 – Hydraulic Piston Pump Breakdown, 74163

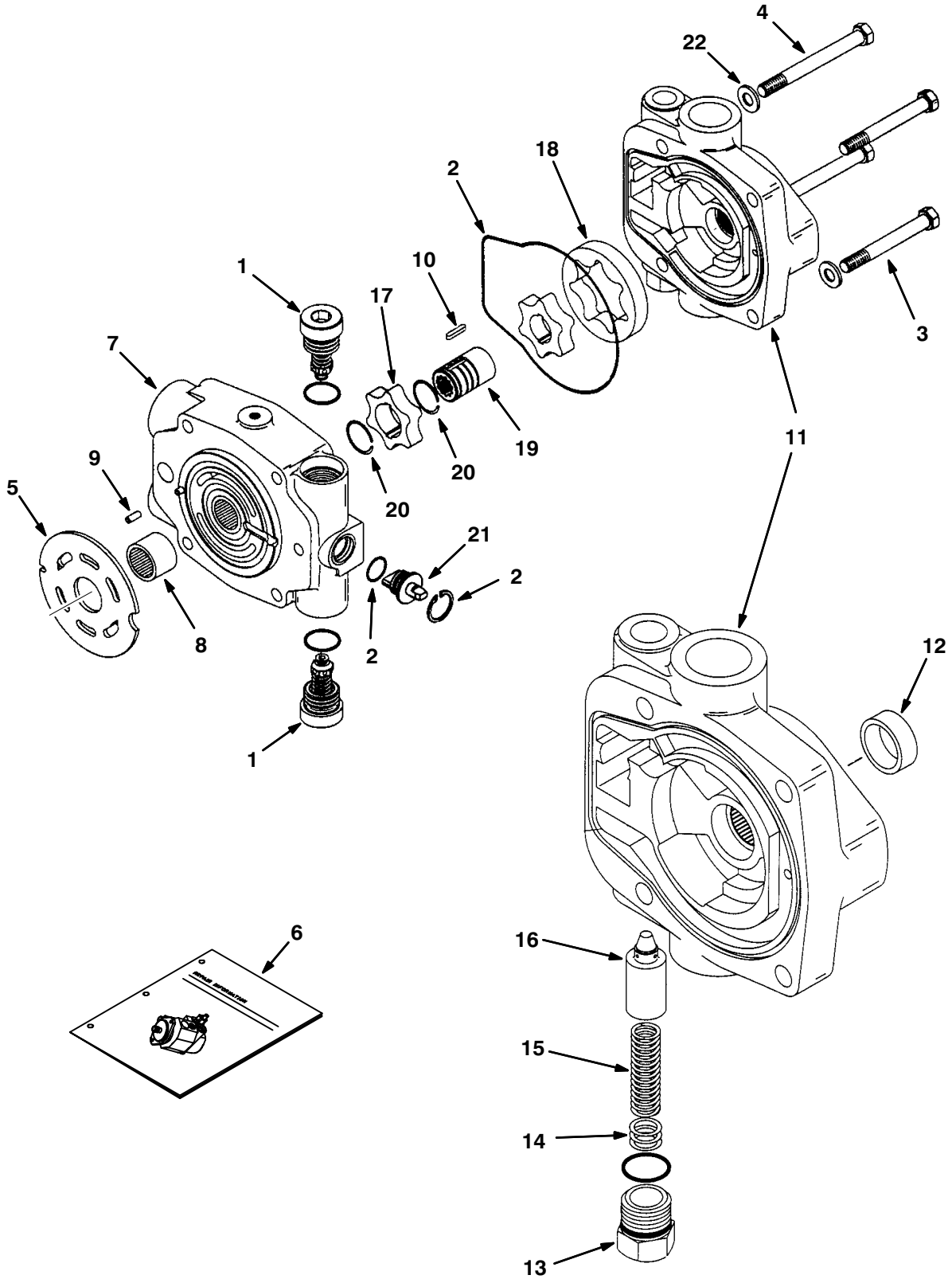

Fig. 4 – Hydraulic Piston Pump Breakdown, 74163

NOTE: Piston Pump, TENNANT Part Number 74163, includes Fig. 3, and Fig. 4.

Ref.	Tennant Part No.	Machine Serial Number	Description	Qty.
∇	74163	(000000–)	Pump, Hyd Piston V 2.48 R4500	1
1	74259	(000000–)	Relief Valve Sa En	2
2	74283	(000000–)	Seal Kit, Pump En	1
3	74260	(000000–)	Screw, Cap En	2
4	74261	(000000–)	Screw, Cap En	2
5	61886	(000000–)	Valve Plate	1
6	79708	(000000–)	Repair Info,Pmp En	1
∇	7	74264	(000000–) Backplate S/A En	1
8	34159	(000000–)	Bearing	1
9	79748	(000000–)	Roll Pin En	1
10	74270	(000000–)	Key En	1
∇	11	74271	(000000–) Charge Pmp Adap En	1
12	79749	(000000–)	Bushing En	1
13	79750	(000000–)	Plug En	1
14	79751	(000000–)	Shims En	1
15	79752	(000000–)	Spring En	1
16	79753	(000000–)	Poppet En	1
17	74274	(000000–)	Geroter,Ring In En	1
18	74275	(000000–)	Geroter,Ring Ot En	1
19	74277	(000000–)	Coupler En	1
20	74278	(000000–)	Ring, Retaining En	2
21	74279	(000000–)	Actuator, Valve En	1
22	74282	(000000–)	Washer En	4

Fig. 5 – Hydraulic Piston Pump Breakdown, 65219

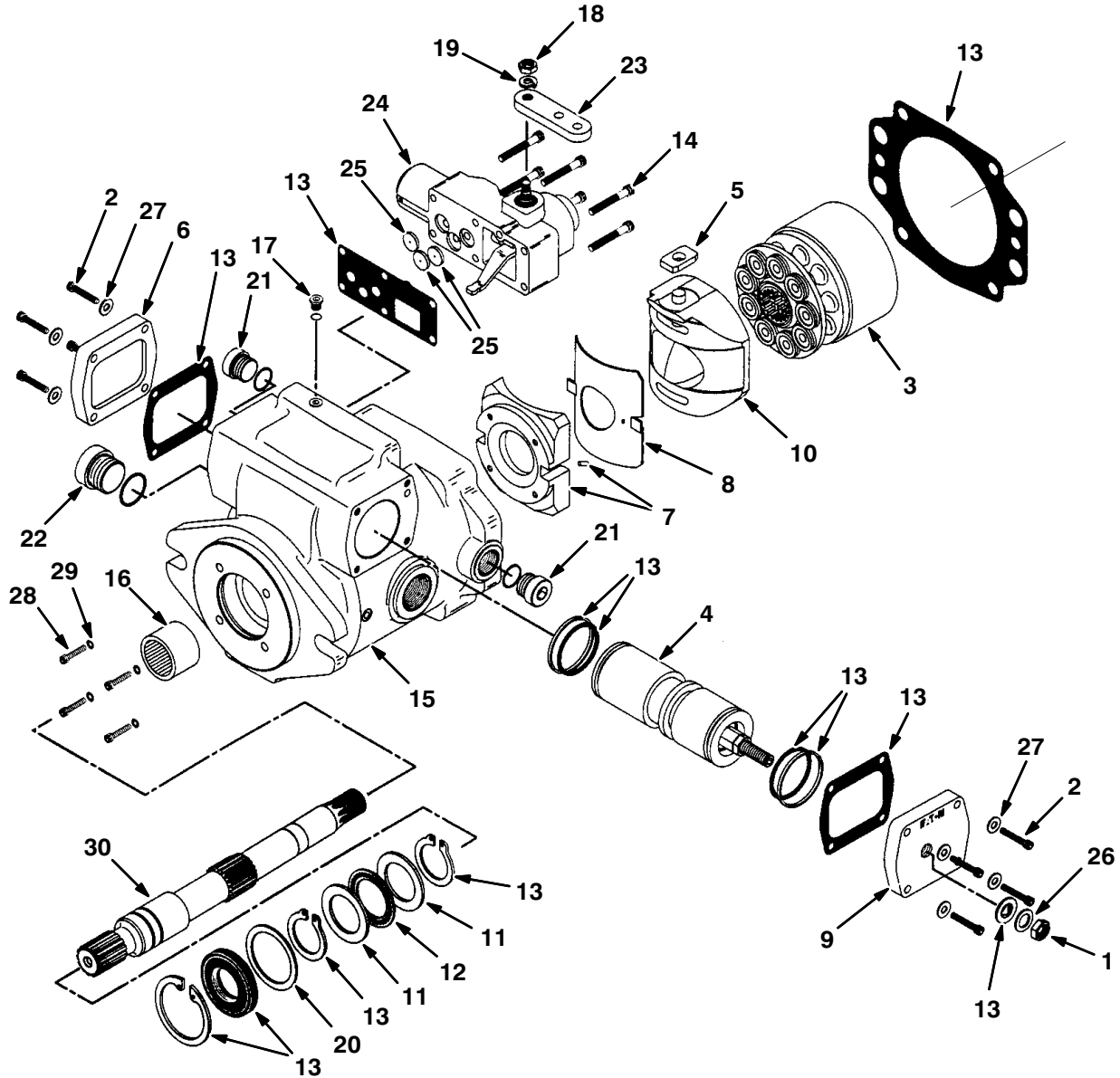

Fig. 5 – Hydraulic Piston Pump Breakdown, 65219

NOTE: Piston Pump, TENNANT Part Number 74163, includes Fig. 5, and Fig. 6.

Ref.	Tennant Part No.	Machine Serial Number	Description	Qty.
∇	62548	(000000–)	Pump–Hyd Piston V 2.48 R4500	1
1	74184	(000000–)	Nut, Jam	1
2	74223	(000000–)	Screw, Cap	8
3	61882	(000000–)	Rotating Kit	1
4	74286	(000000–)	Servo Piston Sa En	1
5	74287	(000000–)	Follower,Piston En	1
6	74256	(000000–)	Plate, Cover En	1
7	74288	(000000–)	Camplate Cradle En	1
8	74289	(000000–)	Cam Bushing En	1
9	74257	(000000–)	Plate, Cover En	1
10	74224	(000000–)	Camplate S/A En	1
11	74240	(000000–)	Race, Bearing Ce	2
12	74210	(000000–)	Bearing	1
13	79709	(000000–)	Seal Kit, Pump En	1
14	74262	(000000–)	Screw, Cap En	6
∇	15 79703	(000000–)	Housing S/A En	1
16	37462	(000000–)	Bearing	1
17	79742	(000000–)	Plug S/A En	1
18	74266	(000000–)	Nut En	1
19	74267	(000000–)	Lockwasher En	1
20	37460	(000000–)	Washer	1
21	13907	(000000–)	Plug #8	2
22	79779	(000000–)	Plug,#12 O–Ring Ph	1
23	74272	(000000–)	Arm, Control En	1
24	74285	(000000–)	Control, Manual (see Breakdown)	1
25	74276	(000000–)	Orifice, Valve En	3
26	74280	(000000–)	Washer En	1
27	74281	(000000–)	Washer En	8
28	79706	(000000–)	Screw, Cap En	4
29	79707	(000000–)	Washer En	4
30	74265	(000000–)	Shaft, Drive Sp En	1

Fig. 6 – Hydraulic Piston Pump Breakdown, 65219

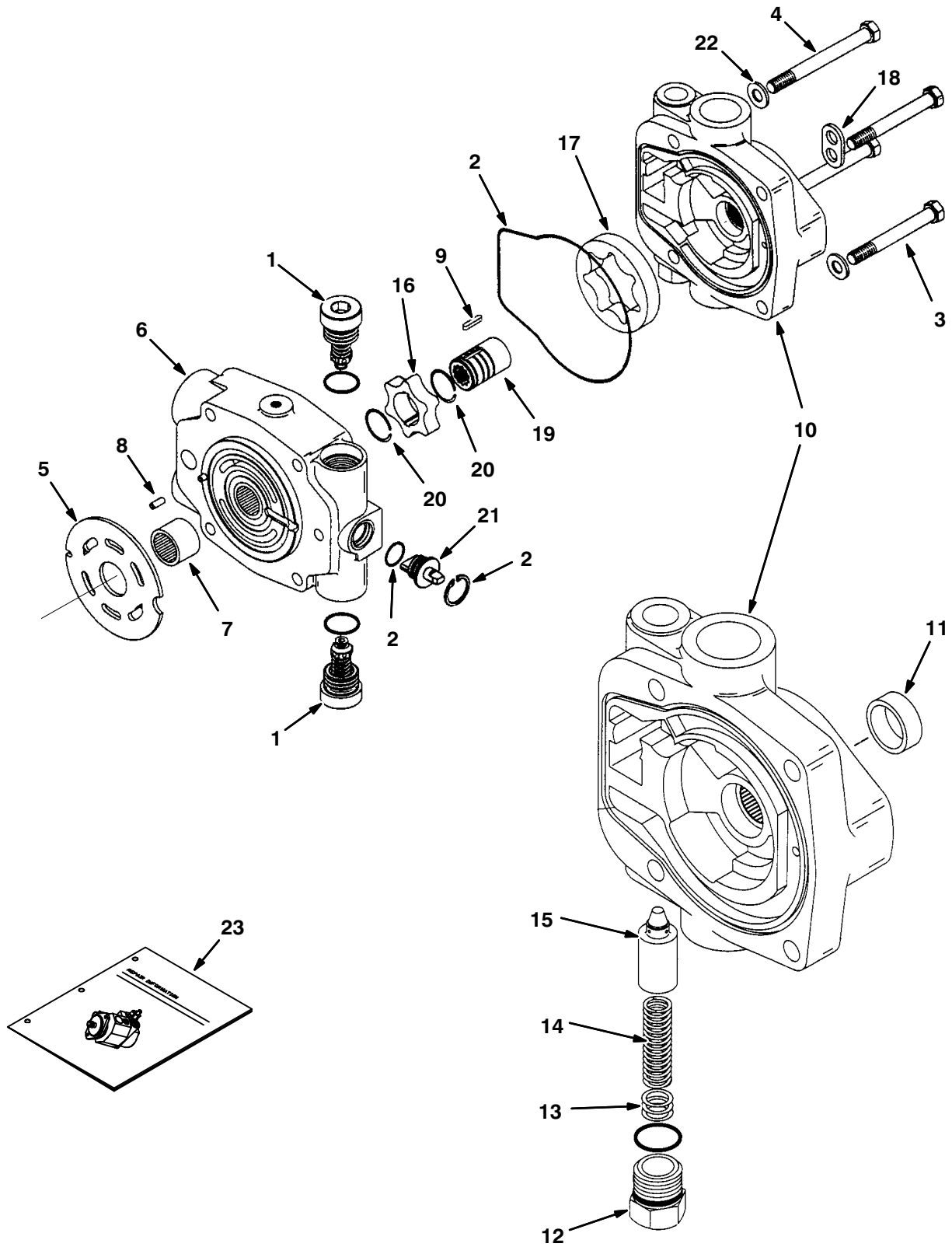

Fig. 6 – Hydraulic Piston Pump Breakdown, 65219

NOTE: Piston Pump, TENNANT Part Number 74163, includes Fig. 5, and Fig. 6.

Ref.	Tennant Part No.	Machine Serial Number	Description	Qty.
∇	62548	(000000–)	Pump–Hyd Piston V 2.48 R4500	1
1	74259	(000000–)	Relief Valve Sa En	2
2	79709	(000000–)	Seal Kit, Pump En	1
3	74260	(000000–)	Screw, Cap En	2
4	74261	(000000–)	Screw, Cap En	2
5	61886	(000000–)	Valve Plate	1
∇	6	79704	(000000–) Backplate S/A En	1
7	34159	(000000–)	Bearing	1
8	79748	(000000–)	Roll Pin En	1
9	74270	(000000–)	Key En	1
∇	10	74271	(000000–) Charge Pmp Adap En	1
11	79749	(000000–)	Bushing En	1
12	79750	(000000–)	Plug En	1
13	79751	(000000–)	Shims En	1
14	79752	(000000–)	Spring En	1
15	79753	(000000–)	Poppet En	1
16	74274	(000000–)	Geroter,Ring In En	1
17	74275	(000000–)	Geroter,Ring Ot En	1
18	79705	(000000–)	Strap, Shipping En	1
19	74277	(000000–)	Coupler En	1
20	74278	(000000–)	Ring, Retaining En	2
21	74279	(000000–)	Actuator, Valve En	1
22	74282	(000000–)	Washer En	4
23	74284	(000000–)	Repair Info,Pmp En	1

Fig. 7 – Hydraulic Piston Pump Breakdown, 74164

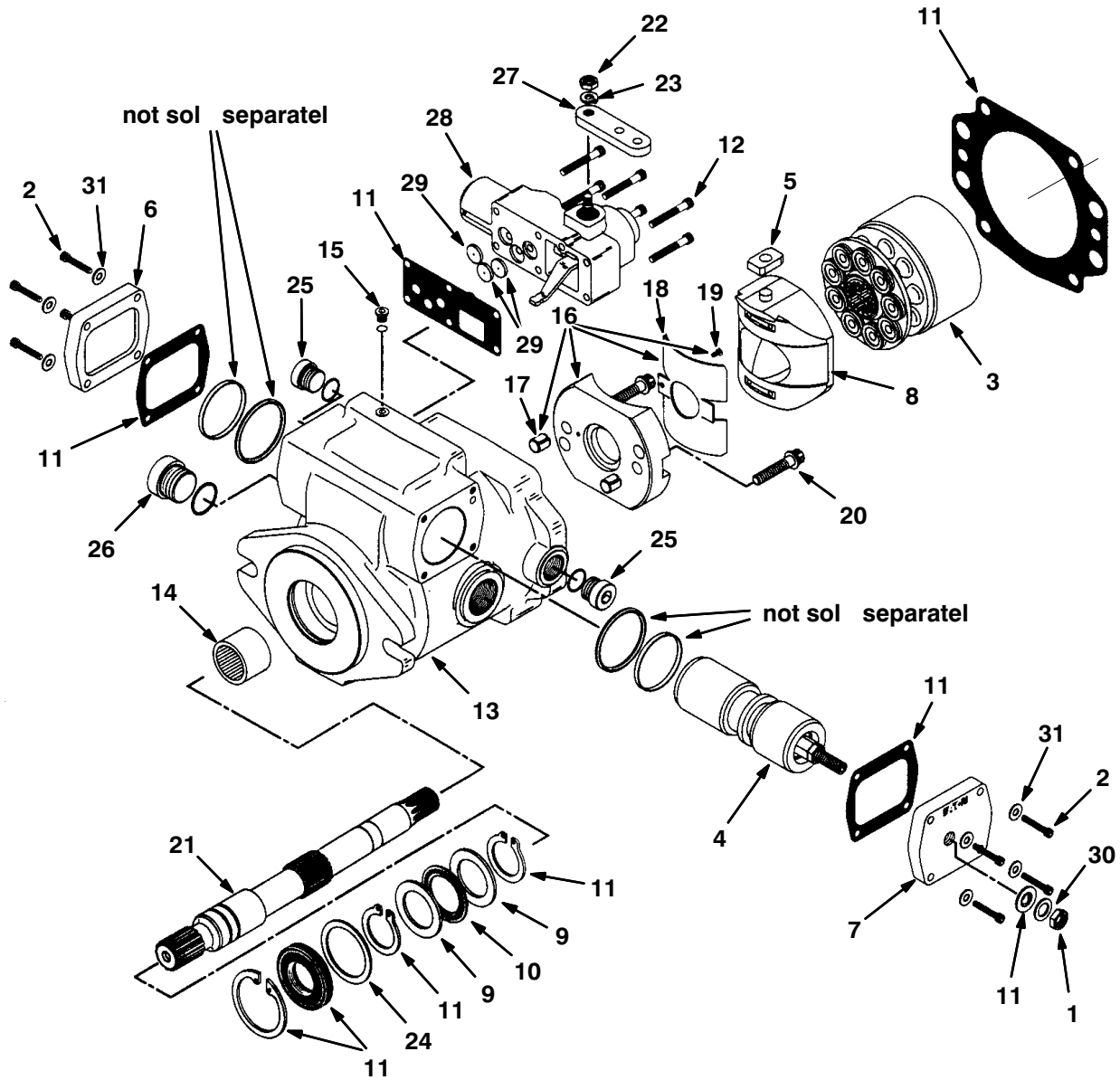

Fig. 7 – Hydraulic Piston Pump Breakdown, 74164

NOTE: Piston Pump, TENNANT Part Number 74164, includes Fig. 7, and Fig. 8.

Ref.	Tennant Part No.	Machine Serial Number	Description	Qty.
∇	74164	(000000–)	Pump, Hyd Piston V 2.48 R4500	1
1	74184	(000000–)	Nut, Jam	1
2	74223	(000000–)	Screw, Cap	8
3	61882	(000000–)	Rotating Kit	1
4	74253	(000000–)	Piston, Servo	1
5	74254	(000000–)	Follower, Piston	1
6	74256	(000000–)	Plate, Cover En	1
7	74257	(000000–)	Plate, Cover En	1
8	74258	(000000–)	Camplate S/A En	1
9	74240	(000000–)	Race, Bearing Ce	2
10	74210	(000000–)	Bearing	1
11	74283	(000000–)	Seal Kit, Pump En	1
12	74262	(000000–)	Screw, Cap En	6
∇	74263	(000000–)	Housing S/A En	1
13	79771	(000000–)	Housing En	1
14	37462	(000000–)	Bearing	1
15	79742	(000000–)	Plug S/A En	1
∇	79743	(000000–)	Cradle Sub Assy En	1
17	79744	(000000–)	Dowel Bushing En	2
18	79745	(000000–)	Bushing En	1
19	79746	(000000–)	Cap Screw En	1
20	79747	(000000–)	Cap Screw En	2
21	74265	(000000–)	Shaft, Drive Sp En	1
22	74266	(000000–)	Nut En	1
23	74267	(000000–)	Lockwasher En	1
24	37460	(000000–)	Washer	1
25	13907	(000000–)	Plug #8	2
26	79779	(000000–)	Plug,#12 O–Ring Ph	1
27	74272	(000000–)	Arm, Control En	1
28	74285	(000000–)	Control, Manual (see Breakdown)	1
29	74276	(000000–)	Orifice, Valve En	1
30	74280	(000000–)	Washer En	1
31	74281	(000000–)	Washer En	8

Fig. 8 – Hydraulic Piston Pump Breakdown, 74164

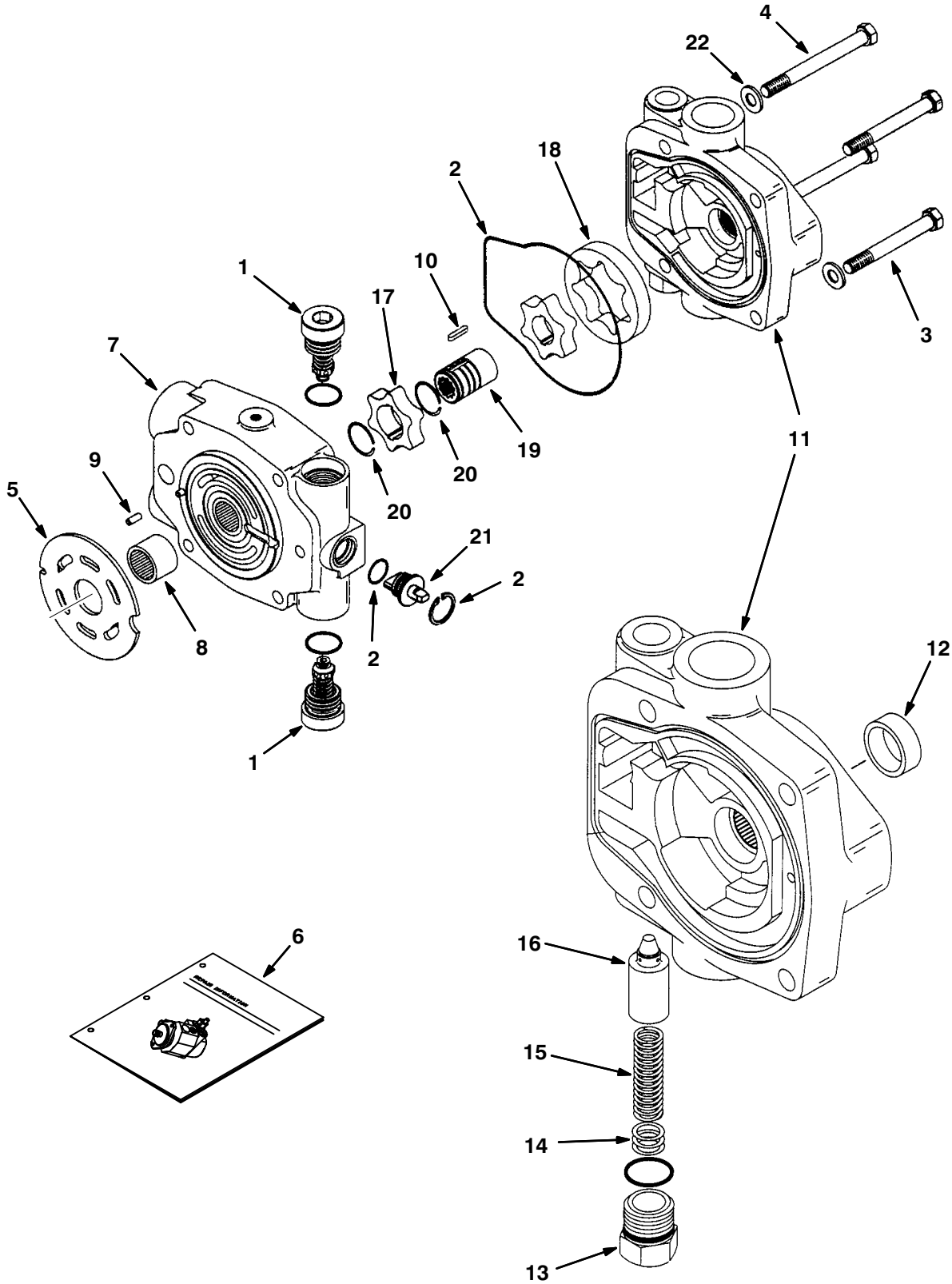
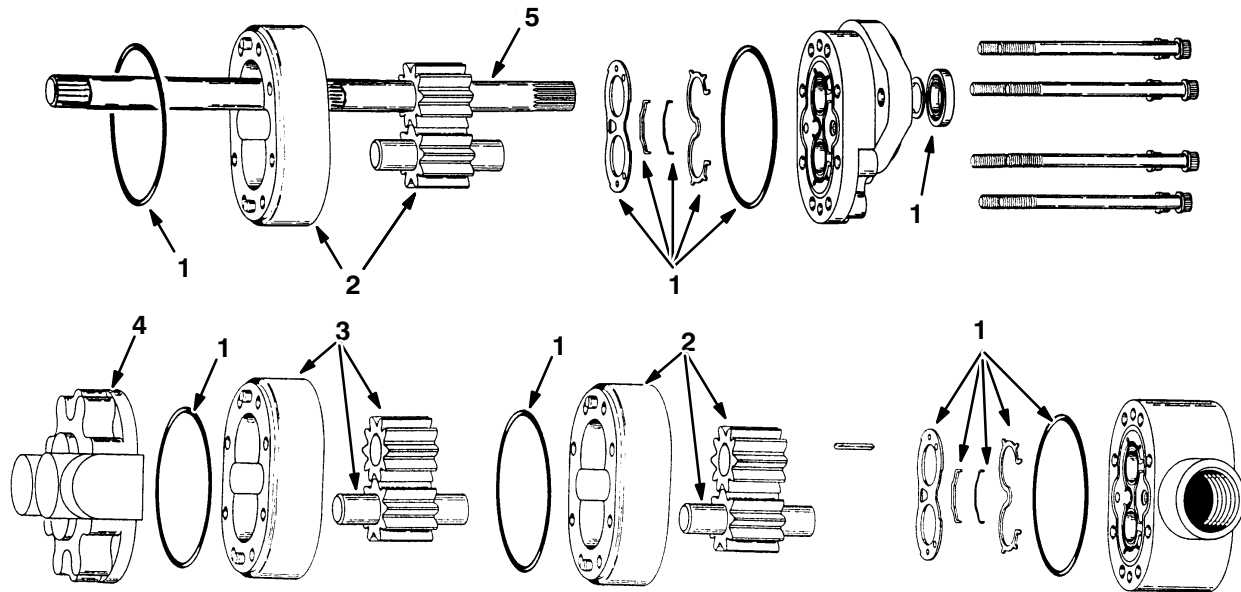

Fig. 8 – Hydraulic Piston Pump Breakdown, 74164

NOTE: Piston Pump, TENNANT Part Number 74164, includes Fig. 7, and Fig. 8.

Ref.	Tennant Part No.	Machine Serial Number	Description	Qty.
∇	74164	(000000–)	Pump, Hyd Piston V 2.48 R4500	1
1	74259	(000000–)	Relief Valve Sa En	2
2	74283	(000000–)	Seal Kit, Pump En	1
3	74260	(000000–)	Screw, Cap En	2
4	74261	(000000–)	Screw, Cap En	2
5	61886	(000000–)	Valve Plate	1
6	79708	(000000–)	Repair Info,Pmp En	1
∇	7	74264	(000000–) Backplate S/A En	1
8	34159	(000000–)	Bearing	1
9	79748	(000000–)	Roll Pin En	1
10	74270	(000000–)	Key En	1
∇	11	74271	(000000–) Charge Pmp Adap En	1
12	79749	(000000–)	Bushing En	1
13	79750	(000000–)	Plug En	1
14	79751	(000000–)	Shims En	1
15	79752	(000000–)	Spring En	1
16	79753	(000000–)	Poppet En	1
17	74274	(000000–)	Geroter,Ring In En	1
18	74275	(000000–)	Geroter,Ring Ot En	1
19	74277	(000000–)	Coupler En	1
20	74278	(000000–)	Ring, Retaining En	2
21	74279	(000000–)	Actuator, Valve En	1
22	74282	(000000–)	Washer En	4

Fig. 9 – Hydraulic Gear Pump Breakdown, 62561



07630/07488

Ref.	Tennant Part No.	Machine Serial Number	Description	Qty.
▽	62561	(000000–)	Pump, Gear	1
1	59305	(000000–)	Seal Kit	1
2	58012	(000000–)	Body and Gear Kit, .66 CIR	2
3	58013	(000000–)	Body and Gear Kit, .50 CIR	1
4	58242	(000000–)	Back Plate Assembly	1
5	65226	(000000–)	Drive Shaft	1

Fig. 10 – Hydraulic Motor Breakdown, 63426

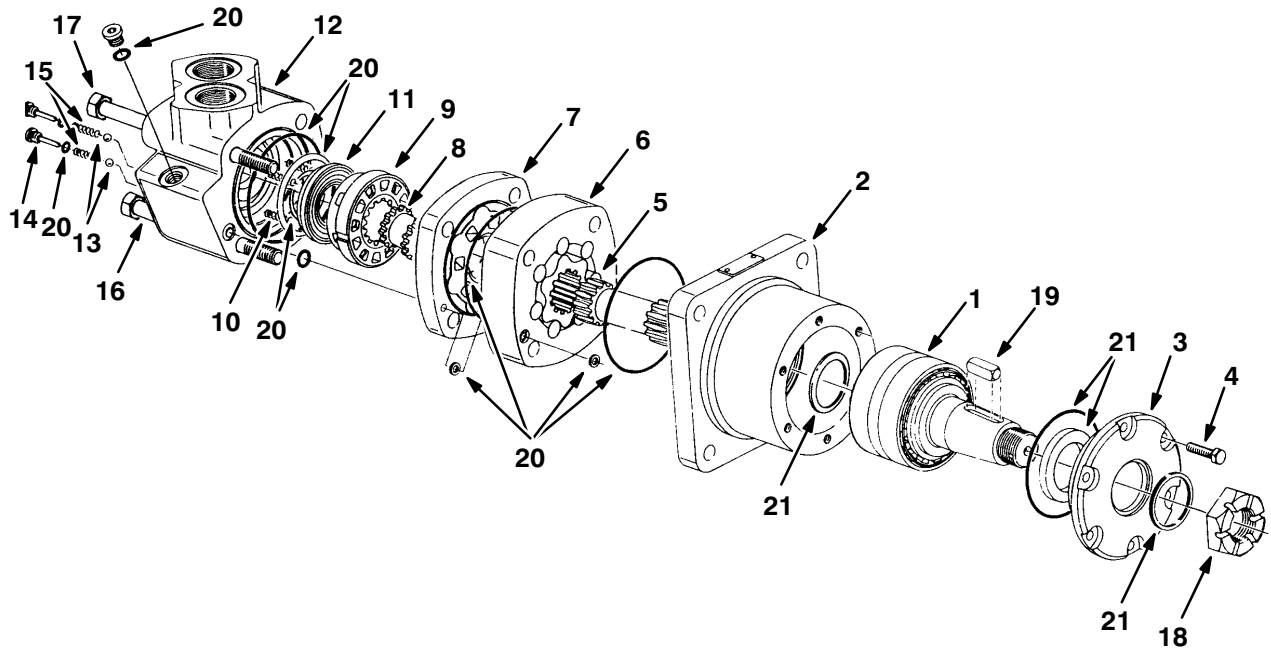

07635/01655

Ref.	Tennant Part No.	Machine Serial Number	Description	Qty.
▽	63426	(000000–) Motor, Propelling	1
1	34180	(000000–) Shaft and Brg	1
2	74132	(000000–) Housing, Brg	1
3	74133	(000000–) Retainer, Frt	1
4	37943	(000000–) Bolt	6
5	34181	(000000–) Drive	1
6	34182	(000000–) Gerotor Set	1
7	34184	(000000–) Valve Plate	1
8	34183	(000000–) Drive, Valve	1
9	34185	(000000–) Valve	1
10	34178	(000000–) Spring	3
11	37723	(000000–) Plate	1
12	74134	(000000–) Housing Assy	1
13	37766	(000000–) Ball	2
14	74137	(000000–) Plug Assembly	2
15	34179	(000000–) Spring	2
16	74135	(000000–) Screw, Cap	2
17	74136	(000000–) Screw, Cap	2
18	45622	(000000–) Nut	1
19	45623	(000000–) Key	1
20	40380	(000000–) Seal Kit, Motor	1
21	65227	(000000–) Seal Kit, Shaft	1

Fig. 11 – Hydraulic Motor Breakdown, 53434

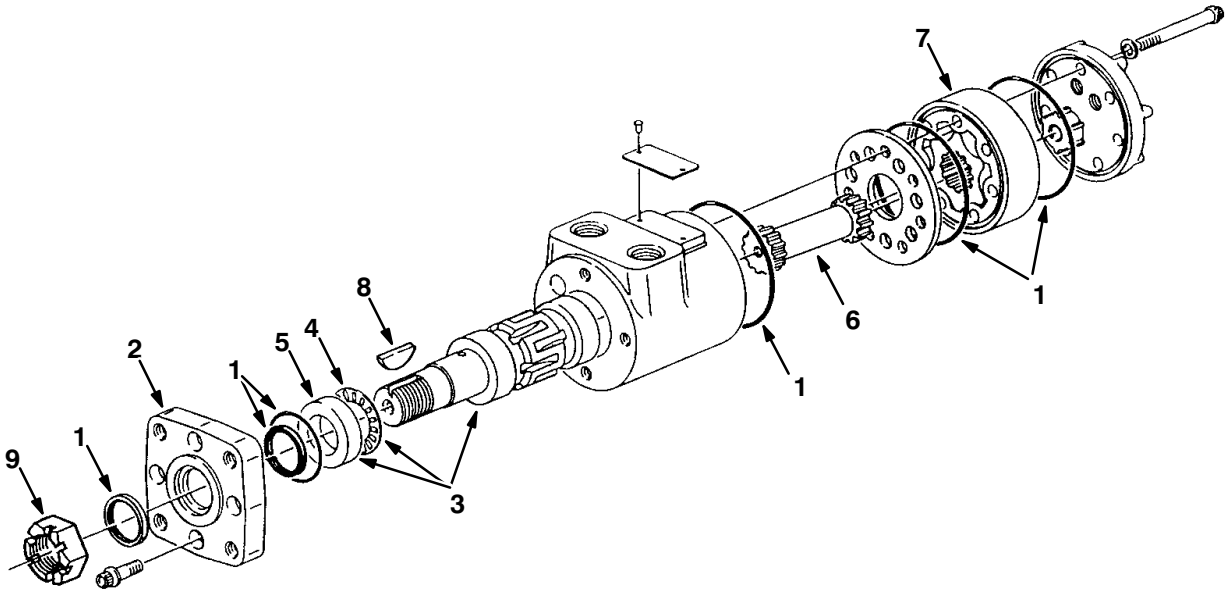

07907/05348

Ref.	Tennant Part No.	Machine Serial Number	Description	Qty.	
▽	53434	(000000–) Motor, Hydraulic	1	
1	61490	(000000–) Seal Kit	1	
2	31354	(000000–) Flange, Mounting	1	
▽	3	58278	(000000–) Output Shaft Assembly	1
4	45628	(000000–) Bearing	1	
5	16695	(000000–) Race, Thrust	1	
6	34176	(000000–) Drive	1	
7	58270	(000000–) Gerotor Set	1	
8	00500–15	(000000–) Key, Woodruff	1	
9	39527	(000000–) Nut, Slotted Hex	1	

Fig. 12 – Hydraulic Motor Breakdown, 62564

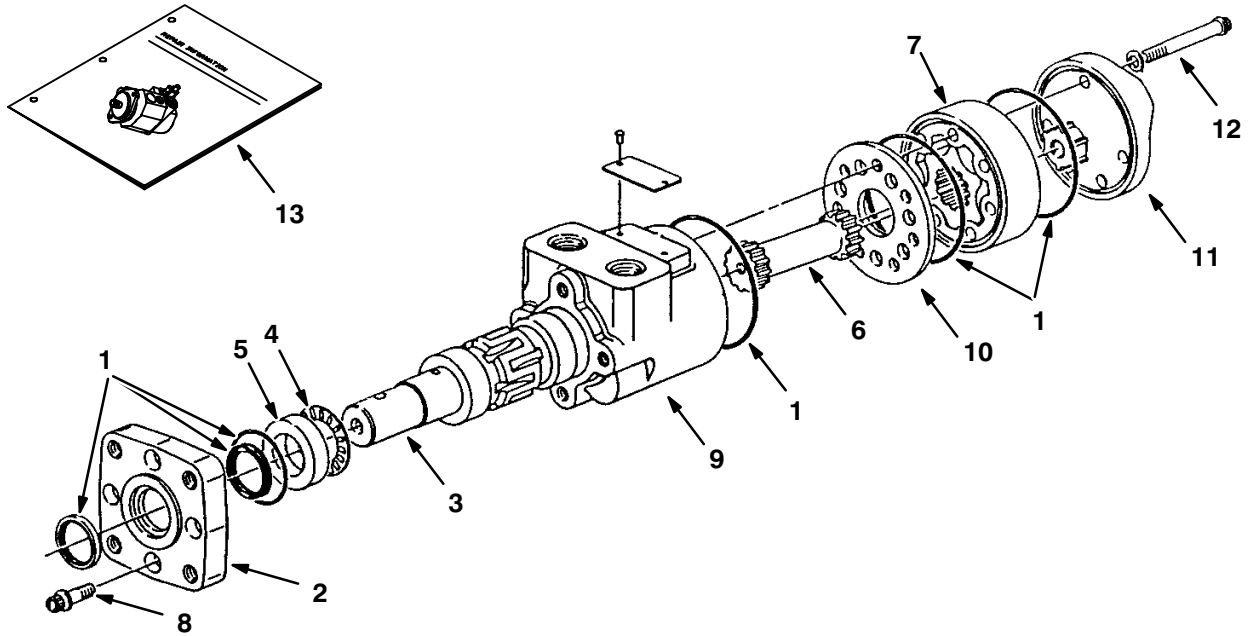

07642/07716,09670

Ref.	Tennant Part No.	Machine Serial Number	Description	Qty.
▽	62564	(000000–) Motor, Hydraulic (Repl. by 79781)	1
1	61490	(000000–) Seal Kit	1
2	31354	(000000–) Flange, Mounting	1
3	16694	(000000–) Shaft	1
4	45628	(000000–) Bearing Thrust	1
5	16695	(000000–) Race, Thrust	1
6	31380	(000000–) Drive	1
7	31385	(000000–) Gerotor Set	1
8	37555	(000000–) Screw	4
9	74100	(000000–) Housing	1
10	74094	(000000–) Spacer Plate	1
11	74101	(000000–) End Cap	1
12	65232	(000000–) Cap Screw	5
13	74250	(000000–) Repair Info, Motor	1

Fig. 13 – Hydraulic Motor Breakdown, 79781

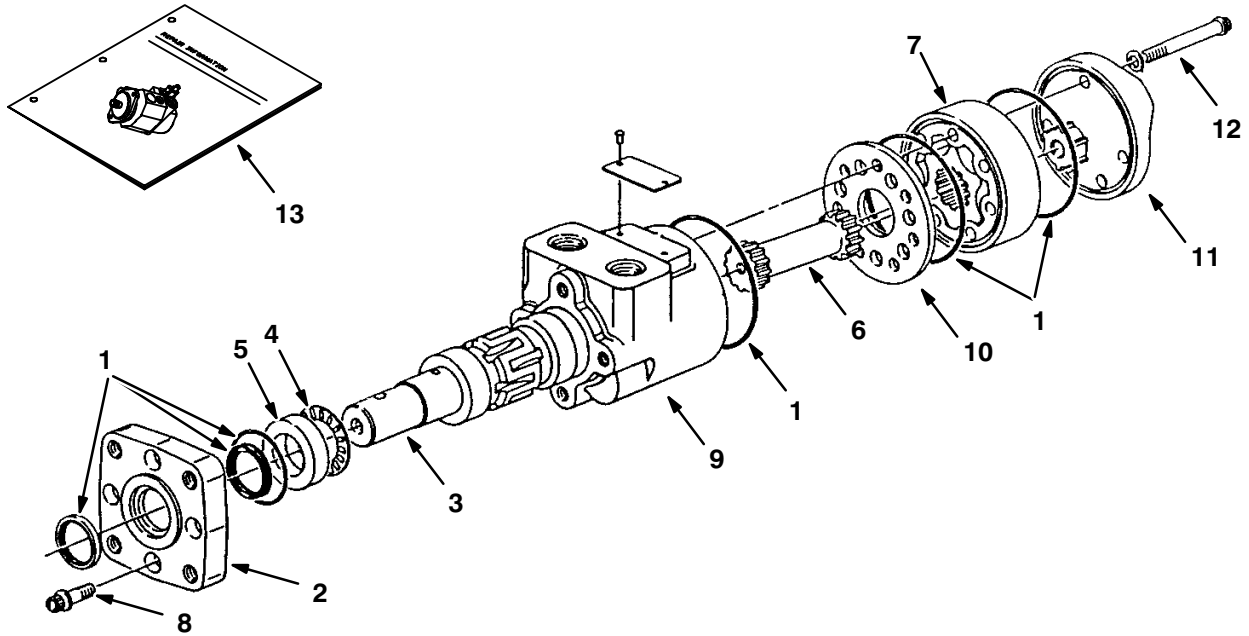

10631/07716,09670

Ref.	Tennant Part No.	Machine Serial Number	Description	Qty.
▽	79781	(000000–) Motor, Hydraulic	1
1	61490	(000000–) Seal Kit	1
2	79782	(000000–) Flange, Mounting	1
3	16694	(000000–) Shaft	1
4	45628	(000000–) Bearing Thrust	1
5	16695	(000000–) Race, Thrust	1
6	31380	(000000–) Drive	1
7	31385	(000000–) Gerotor Set	1
8	37555	(000000–) Screw	4
9	74100	(000000–) Housing	1
10	74094	(000000–) Spacer Plate	1
11	74101	(000000–) End Cap	1
12	65232	(000000–) Cap Screw	5
13	74250	(000000–) Repair Info, Motor	1

Fig. 14 – Hydraulic Motor Breakdown, 19117

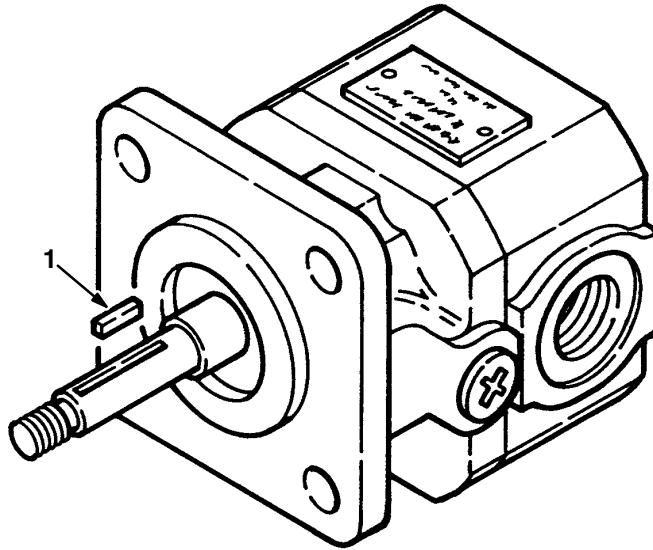

05187/05190

Ref.	Tennant Part No.	Machine Serial Number	Description	Qty.
∇	19117	(000000–) Motor, Hydraulic	1
1	00954	(000000–) Key	1
	74233	(000000–) Seal Kit	1

Fig. 15 – Hydraulic Motor Breakdown, 63542

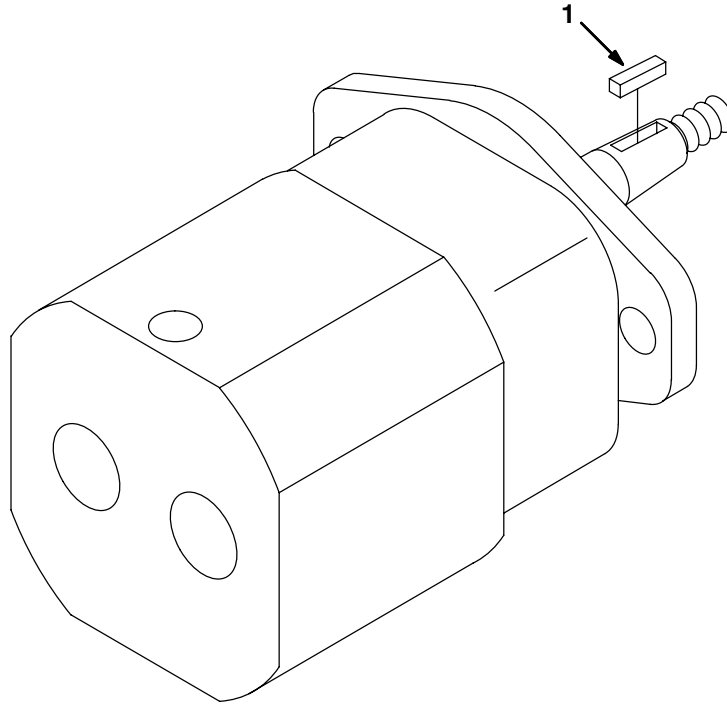

07631/10556

Ref.	Tennant Part No.	Machine Serial Number	Description	Qty.
∇	63542	(000000–) Motor, Hydraulic	1
1	00960	(000000–) Key, Square 0.12 0.12 00.50 LG	1
	74233	(000000–) Seal Kit, Hyd Mtr Gear	1

Fig. 16 – Hydraulic Steering Valve Breakdown, 62565

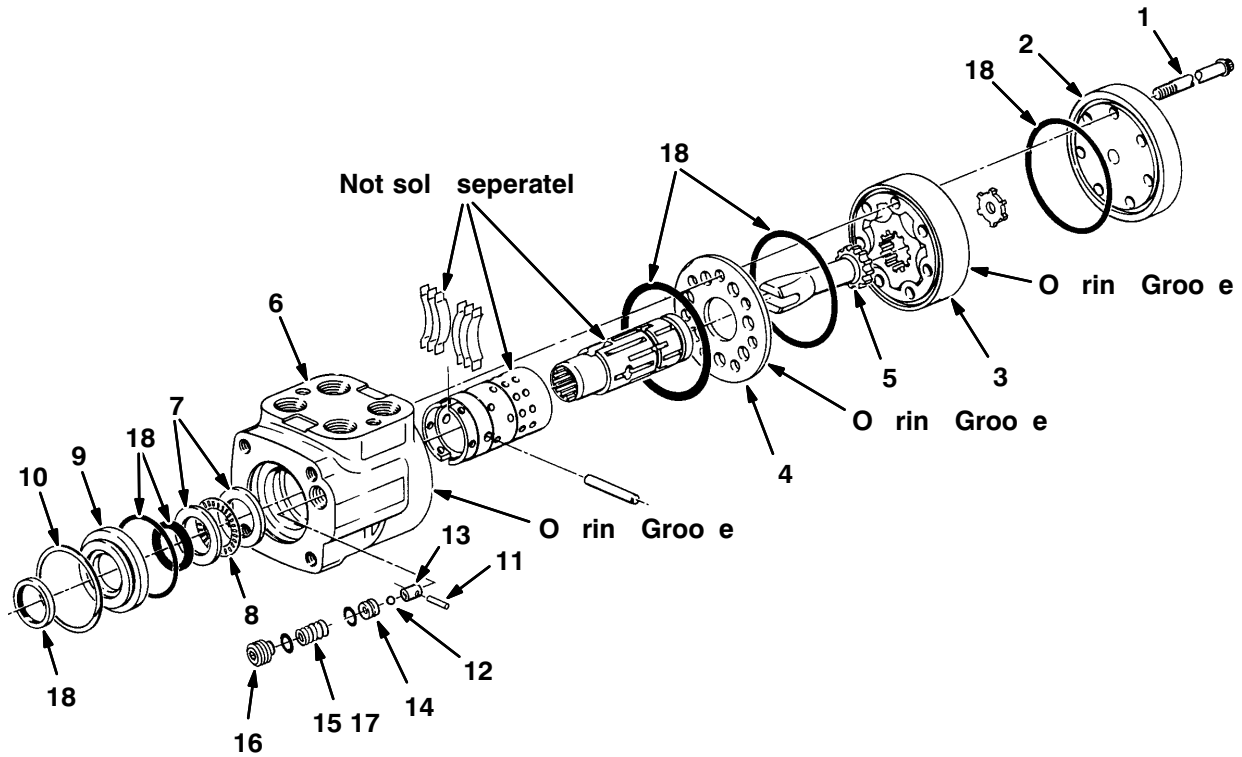

07636/07491

Ref.	Tennant Part No.	Machine Serial Number	Description	Qty.
▽	62565	(000000–)	Steer Control, Hyd#4 04.5 1300	1
1	65233	(000000–)	Cap Screw CI	6
2	65234	(000000–)	Cap, End CI	1
3	65235	(000000–)	Gerotor Set CI	1
4	74106	(000000–)	Spacer Plate	1
5	58596	(000000–)	Drive	1
6	65236	(000000–)	Control Assy CI	1
7	74109	(000000–)	Race, Bearing	2
8	74110	(000000–)	Bearing, Needle	1
9	74112	(000000–)	Bushing, Seal	1
10	74111	(000000–)	Ring, Retainer	1
11	74113	(000000–)	Pin, Spring CI	1
12	74114	(000000–)	Ball, Check CI	1
13	74115	(000000–)	Seat	1
14	74116	(000000–)	Poppet	1
15	65237	(000000–)	Spring, Comp. CI	1
16	74118	(000000–)	Plug	1
17	65238	(000000–)	Spring, Comp. CI	1
18	57152	(000000–)	Seal Kit,Stg	1

Fig. 17 – Hydraulic Steering Valve Breakdown, 65242

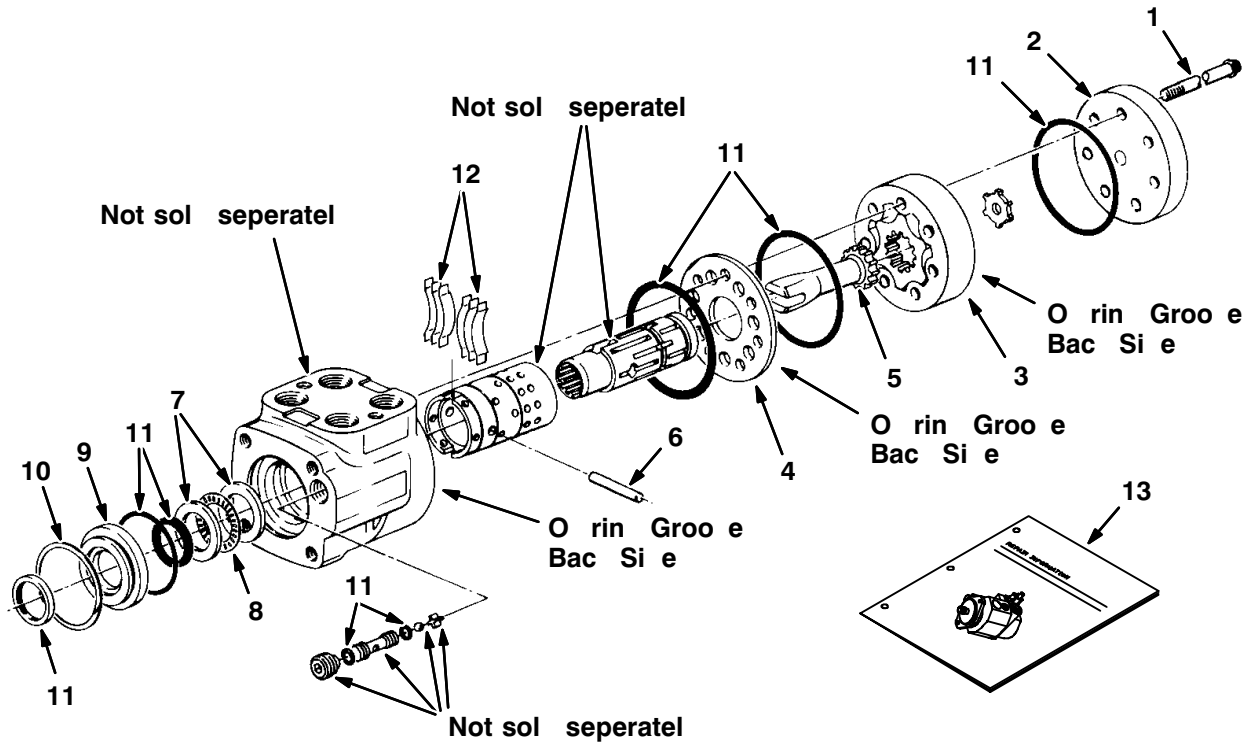

09937/09936/09670

Ref.	Tennant Part No.	Machine Serial Number	Description	Qty.
▽	65242	(000000–)	Steer Control Hyd#4 04.5 1300	1
1	74174	(000000–)	Cap, Screw	6
2	74194	(000000–)	Cap, End	1
3	65235	(000000–)	Gerotor Set Cl	1
4	74182	(000000–)	Plate, Wear	1
5	58596	(000000–)	Drive	1
6	74218	(000000–)	Pin	1
7	74109	(000000–)	Race, Bearing	2
8	74110	(000000–)	Bearing, Needle	1
9	74112	(000000–)	Bushing, Seal	1
10	74111	(000000–)	Ring, Retainer	1
11	74190	(000000–)	Seal Kit, Scu	1
12	74251	(000000–)	Repair Info,Scu Cl	1

Fig. 18 – Hydraulic Solenoid Valve Breakdown, 65391

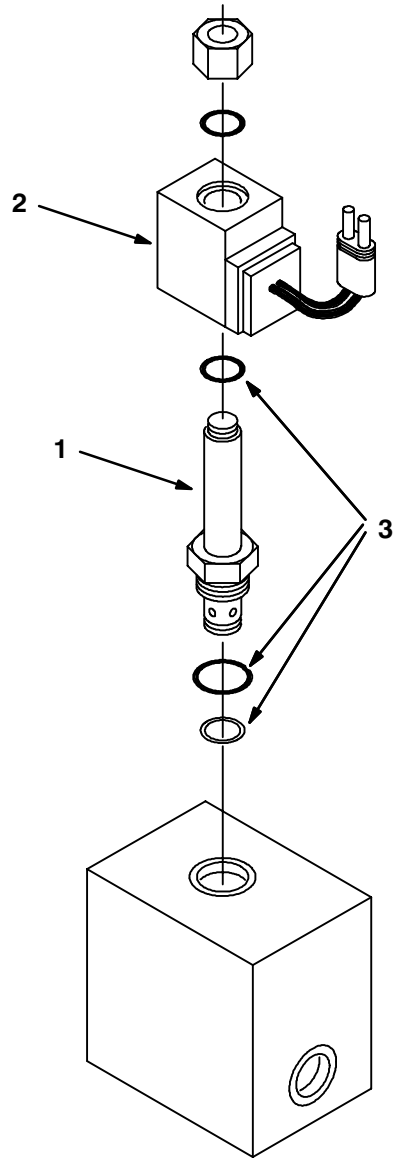

07638/07639

	Tennant	Machine		Description	Qty.
Ref.	Part No.	Serial Number			
∇	65391	(000000–)	Valve–Hyd, Solenoid	1
1	61927	(000000–)	Valve Stem N.O.	1
2	35493	(000000–)	Coil 12Vdc	1
3	48813	(000000–)	Seal Kit, One Cart	1

Fig. 19 – Hydraulic Solenoid Valve Breakdown, 84015

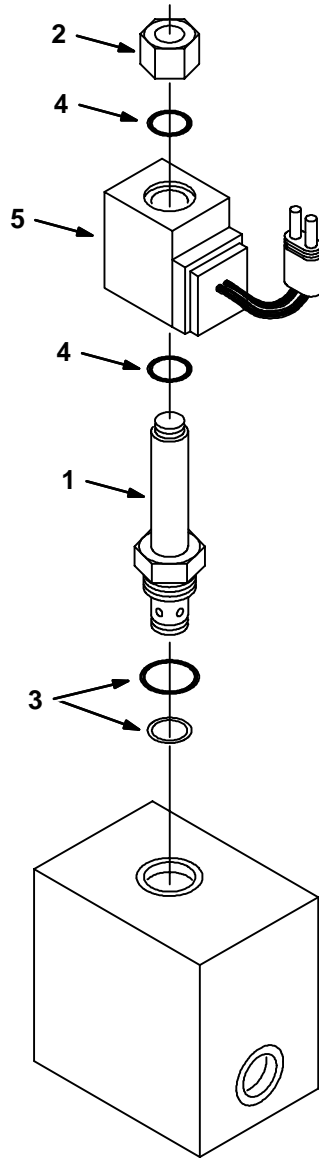

10632/07639

Ref.	Tennant Part No.	Machine Serial Number	Description	Qty.
∇	84015	(000000–) Valve – Hyd., Solenoid	1
∇	1 79739	(000000–) Valve Stem, N.D.	1
	2 79731	(000000–) Nut, Cart., LNG.	1
	3 79711	(000000–) Seal Kit, Cart.	1
	4 79740	(000000–) Seal Kit, Coil	1
	5 21917	(000000–) Coil, 12V W/Var	1

Fig. 20 – Hydraulic Solenoid Valve Breakdown, 84016

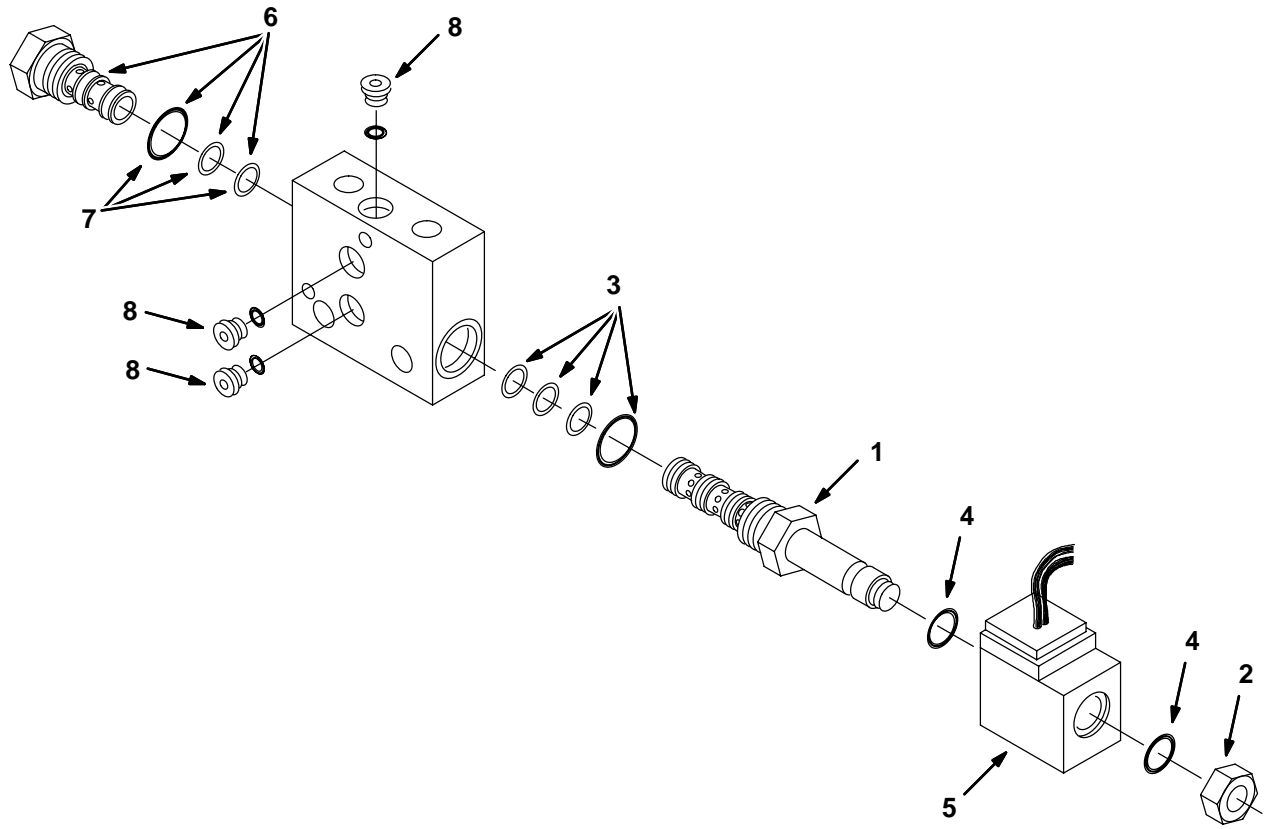

10500/10499

Ref.	Tennant Part No.	Machine Serial Number	Description	Qty.
▽	84016	(000000–) Valve, Hyd Control Solenoid	1
▽	1	79719	(000000–) Valve Stem 4W2P	1
	2	79728	(000000–) Nut, Cart., Sht	1
	3	79711	(000000–) Seal Kit, Cart	1
	4	79740	(000000–) Seal Kit, Coil	1
	5	21917	(000000–) Coil, 12V W/Var	1
▽	6	74145	(000000–) Cart, Pilot Cntr	1
	7	79711	(000000–) Seal Kit, Cart	1
	8	13902	(000000–) Plug, #2 O-Ring	3

Fig. 21 – Hydraulic Solenoid Valve Breakdown, 63527

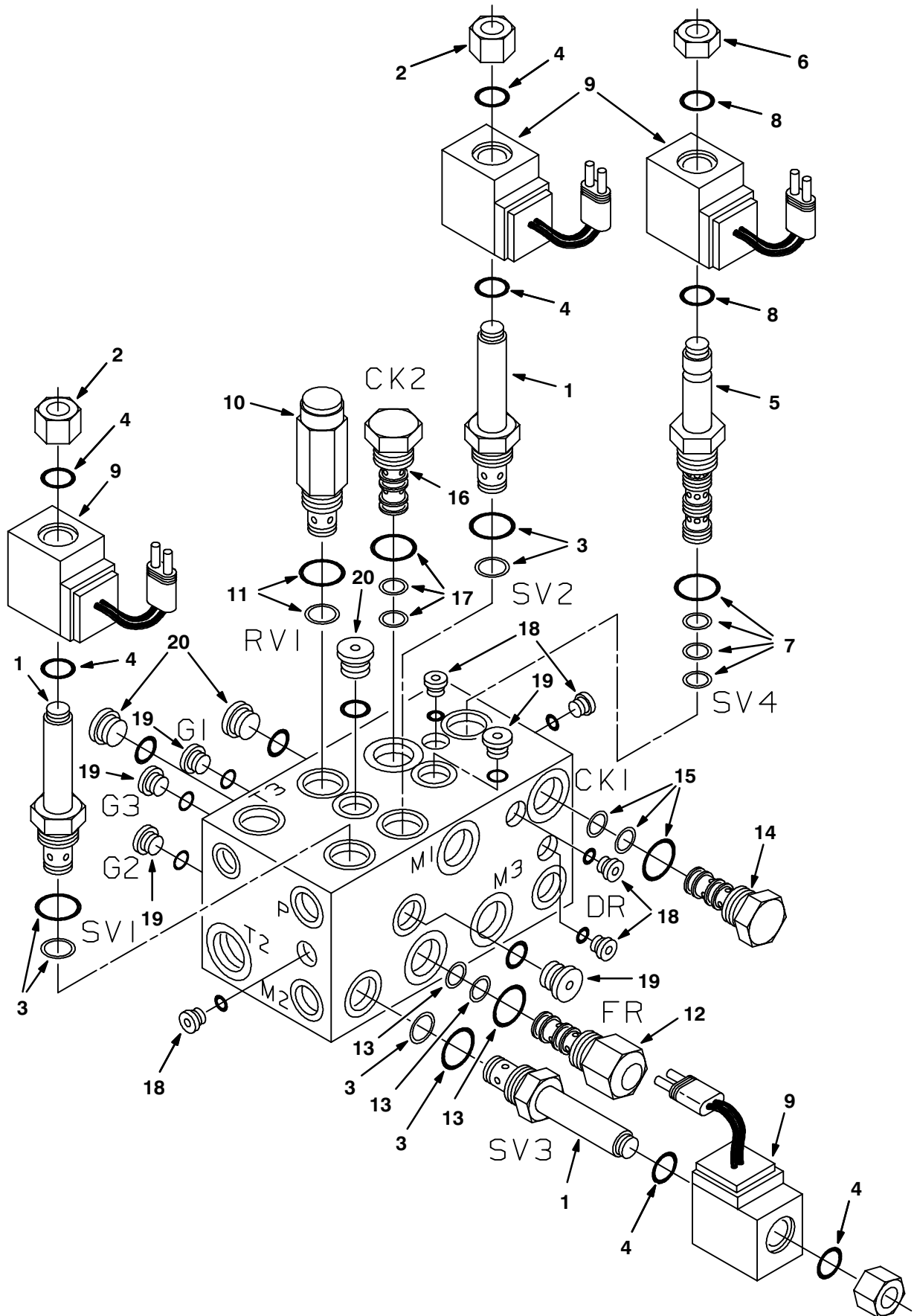

Fig. 21 – Hydraulic Solenoid Valve Breakdown, 63527

Ref.	Tenant Part No.	Machine Serial Number	Description	Qty.
∇	63527	(000000–)	Valve–Hyd, Cntl Solenoid	1
∇ 1	79739	(000000–)	Valve Stem N.O. CP	3
2	79731	(000000–)	Nut, Cart., LNG CP	1
3	79711	(000000–)	Seal Kit, Cart CP	1
4	79740	(000000–)	Seal Kit, C0il CP	1
∇ 5	79719	(000000–)	Valve Stem 4W2P CP	1
6	79728	(000000–)	Nut, Cart., SHT CP	1
7	79711	(000000–)	Seal Kit, Cart CP	1
8	79740	(000000–)	Seal Kit, C0il CP	1
9	79720	(000000–)	Coil 12V CP	4
∇ 10	65240	(000000–)	Cart, PSI CN CP	1
11	79711	(000000–)	Seal Kit, Cart CP	1
∇ 12	74268	(000000–)	Cart Flow Control CP	1
13	79711	(000000–)	Seal Kit, Cart CP	1
∇ 14	74145	(000000–)	Cart, Pilot CNTR CP	1
15	79711	(000000–)	Seal Kit, Cart CP	1
∇ 16	74146	(000000–)	Cart, Check Valve CP	1
17	79711	(000000–)	Seal Kit, Cart CP	1
18	13902	(000000–)	Plug #2	6
19	74098	(000000–)	Plug Gage #4	5
20	13904	(000000–)	Plug Gage #6	3

Fig. 22 – Hydraulic Solenoid Valve Breakdown, 78996

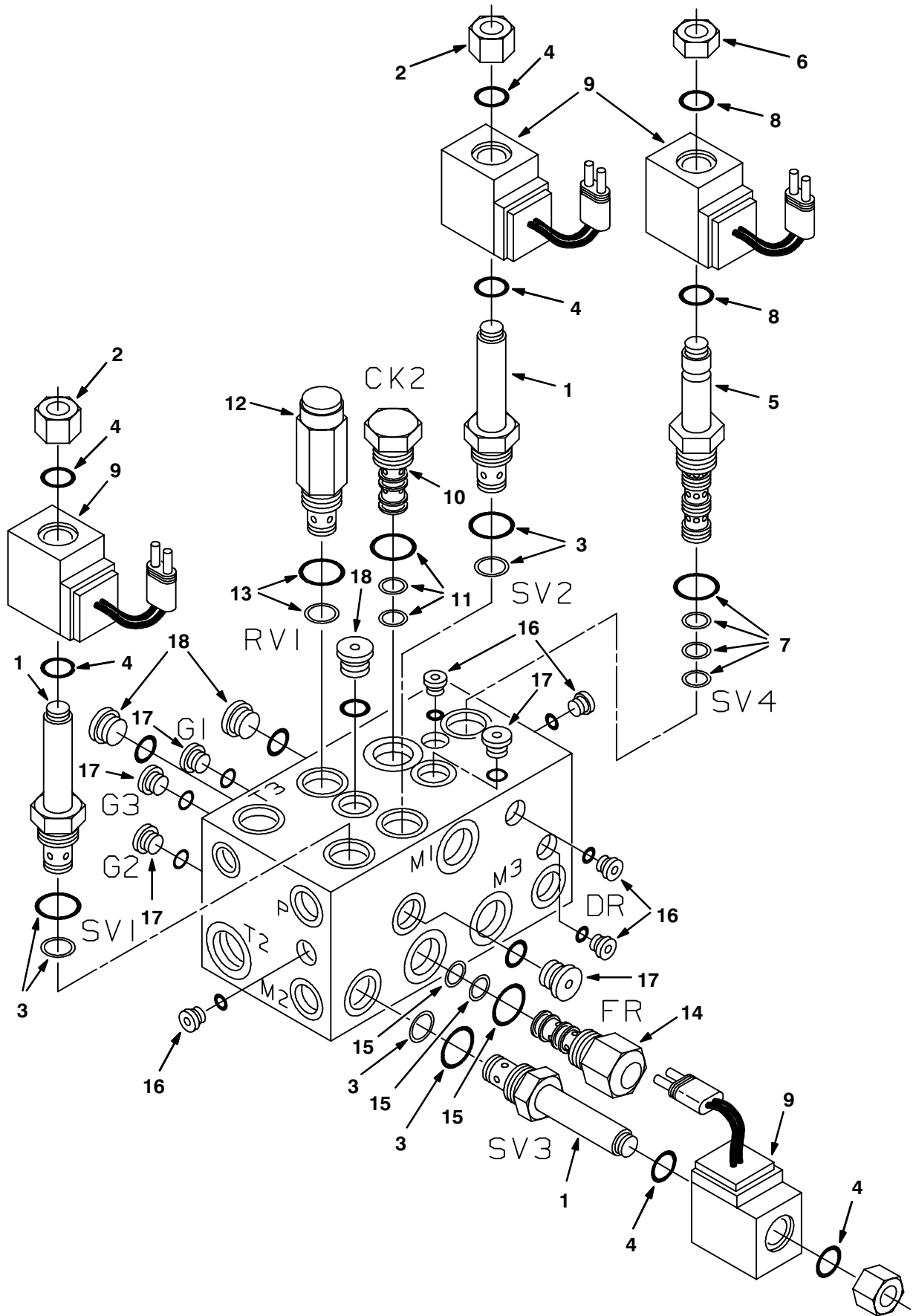

Fig. 22 – Hydraulic Solenoid Valve Breakdown, 78996

Ref.	Tennant Part No.	Machine Serial Number	Description	Qty.
∇	78996	(000000–)	Valve–Hyd, Solenoid	1
∇ 1	79739	(000000–)	Valve Stem N.O. CP	3
2	79731	(000000–)	Nut, Cart., LNG CP	1
3	79711	(000000–)	Seal Kit, Cart CP	1
4	79740	(000000–)	Seal Kit, C0il CP	1
∇ 5	79719	(000000–)	Valve Stem 4W2P CP	1
6	79728	(000000–)	Nut, Cart., SHT CP	1
7	79711	(000000–)	Seal Kit, Cart CP	1
8	79740	(000000–)	Seal Kit, C0il CP	1
9	79720	(000000–)	Coil 12V CP	4
∇ 10	74146	(000000–)	Cart, Check Valve CP	1
11	79711	(000000–)	Seal Kit, Cart CP	1
∇ 12	65240	(000000–)	Cart, PSI CN CP	1
13	79711	(000000–)	Seal Kit, Cart CP	1
∇ 14	74268	(000000–)	Cart Flow Control CP	1
15	79711	(000000–)	Seal Kit, Cart CP	1
16	13902	(000000–)	Plug #2	6
17	74098	(000000–)	Plug Gage #4	5
18	13904	(000000–)	Plug Gage #6	3

Fig. 23 – Hydraulic Solenoid Valve Breakdown, 84014

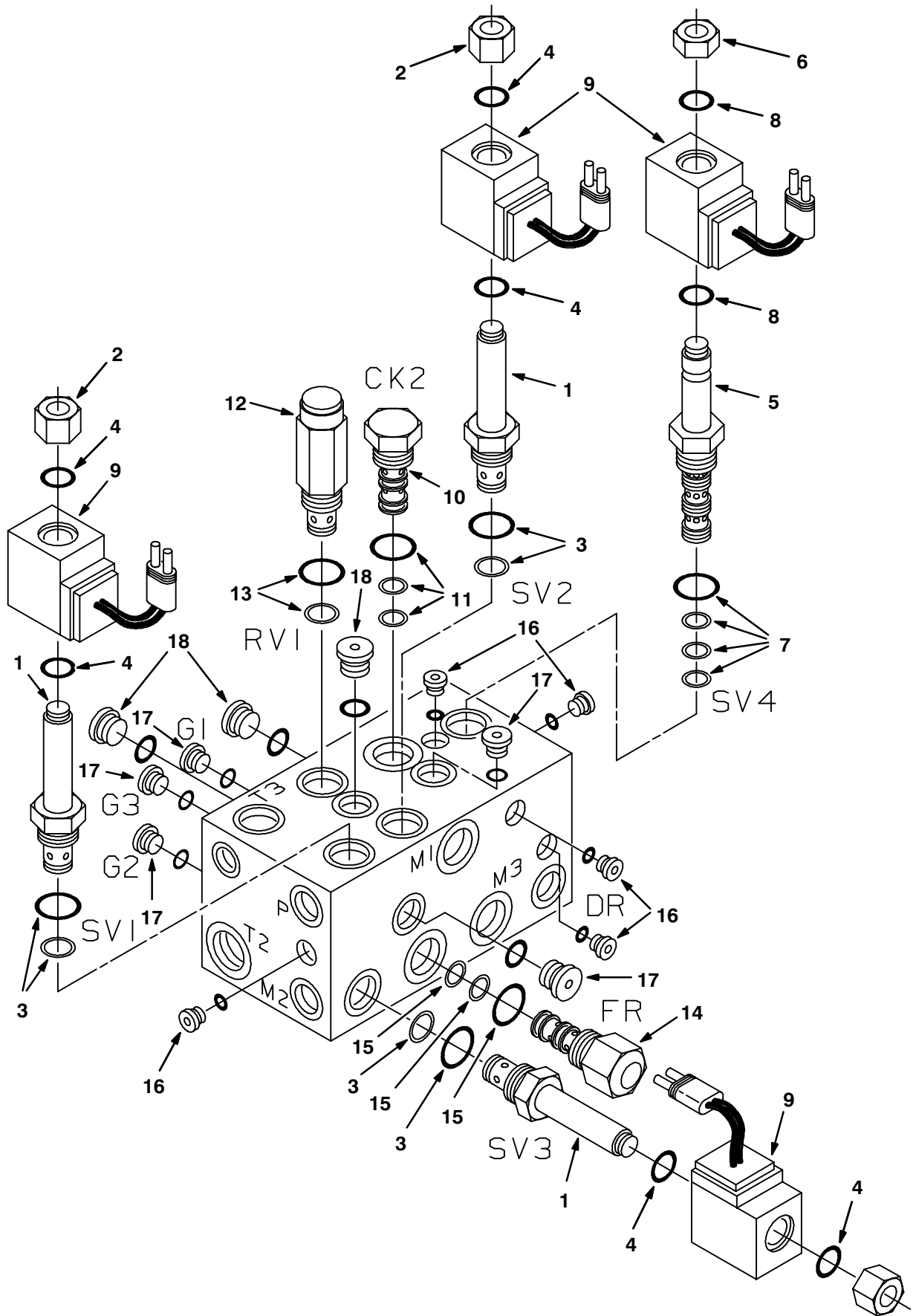
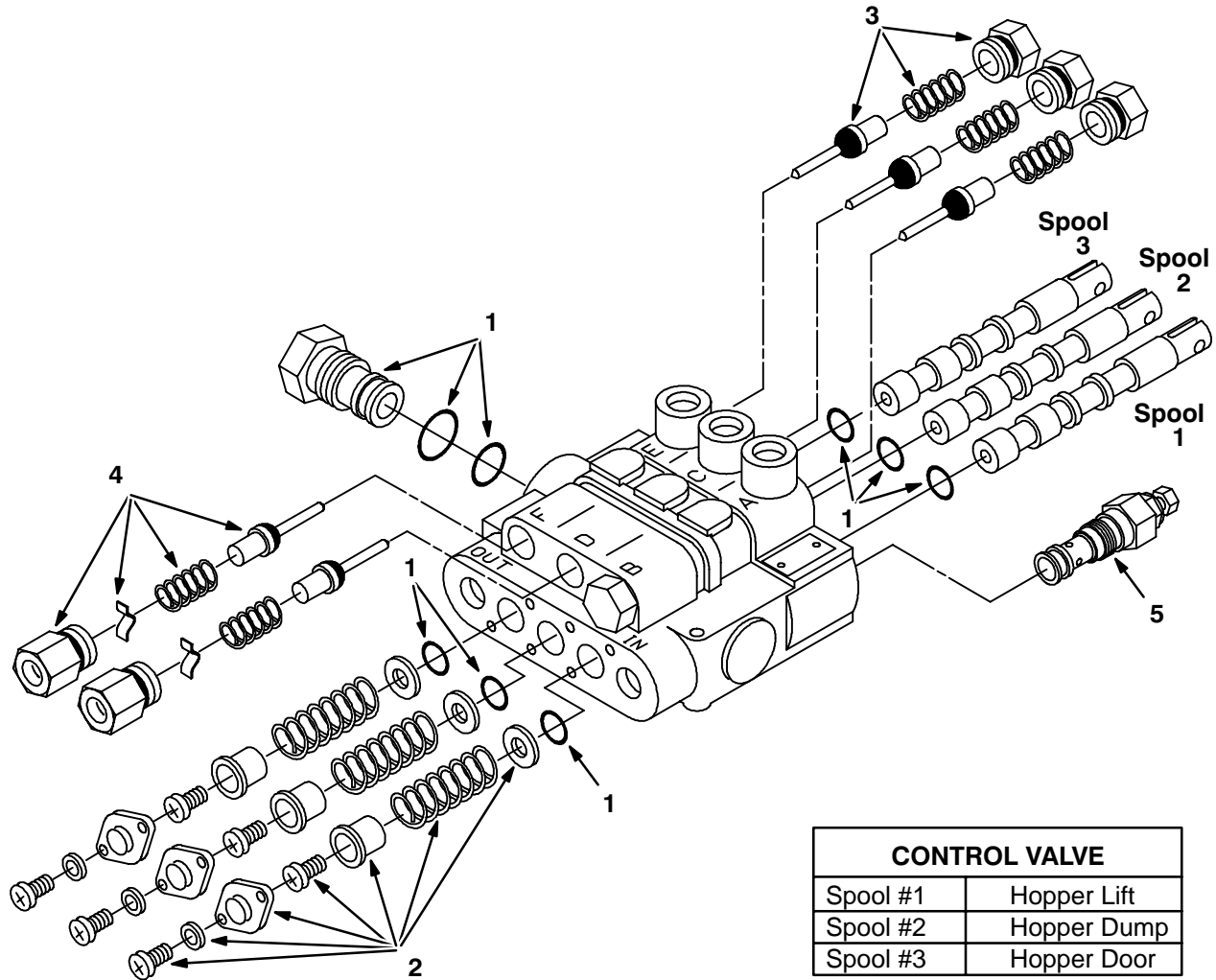

Fig. 23 – Hydraulic Solenoid Valve Breakdown, 84014

Ref.	Tenant Part No.	Machine Serial Number	Description	Qty.
∇	84014	(000000–) Valve, Hyd Control Solenoid	1
∇ 1	79739	(000000–) Valve Stem N.O. CP	3
2	79731	(000000–) Nut, Cart., LNG CP	1
3	79711	(000000–) Seal Kit, Cart CP	1
4	79740	(000000–) Seal Kit, Coil CP	1
∇ 5	79719	(000000–) Valve Stem 4W2P CP	1
6	79728	(000000–) Nut, Cart., SHT CP	1
7	79711	(000000–) Seal Kit, Cart CP	1
8	79740	(000000–) Seal Kit, Coil CP	1
9	21917	(000000–) Coil 12V w/Var CP	4
∇ 10	74146	(000000–) Cart, Check Valve CP	1
11	79711	(000000–) Seal Kit, Cart CP	1
∇ 12	65240	(000000–) Cart, PSI CN CP	1
13	79711	(000000–) Seal Kit, Cart CP	1
∇ 14	74268	(000000–) Cart Flow Control CP	1
15	79711	(000000–) Seal Kit, Cart CP	1
16	13902	(000000–) Plug #2	6
17	74098	(000000–) Plug Gage #4	5
18	13904	(000000–) Plug Gage #6	3

Fig. 24 – Hydraulic Valve Breakdown, 62567



CONTROL VALVE	
Spool #1	Hopper Lift
Spool #2	Hopper Dump
Spool #3	Hopper Door

07640/07641

Ref.	Tennant Part No.	Machine Serial Number	Description	Qty.
▽	62567	(000000–)	Valve, Hydraulic	1
1	74128	(000000–)	Seal Kit	1
2	74126	(000000–)	Spring Kit	3
3	74129	(000000–)	Check Kit, Pilot	3
4	74130	(000000–)	Check Kit, Pilot	2
5	74131	(000000–)	Relief Cart.	1

Fig. 25 – Hydraulic Valve Breakdown, 77495

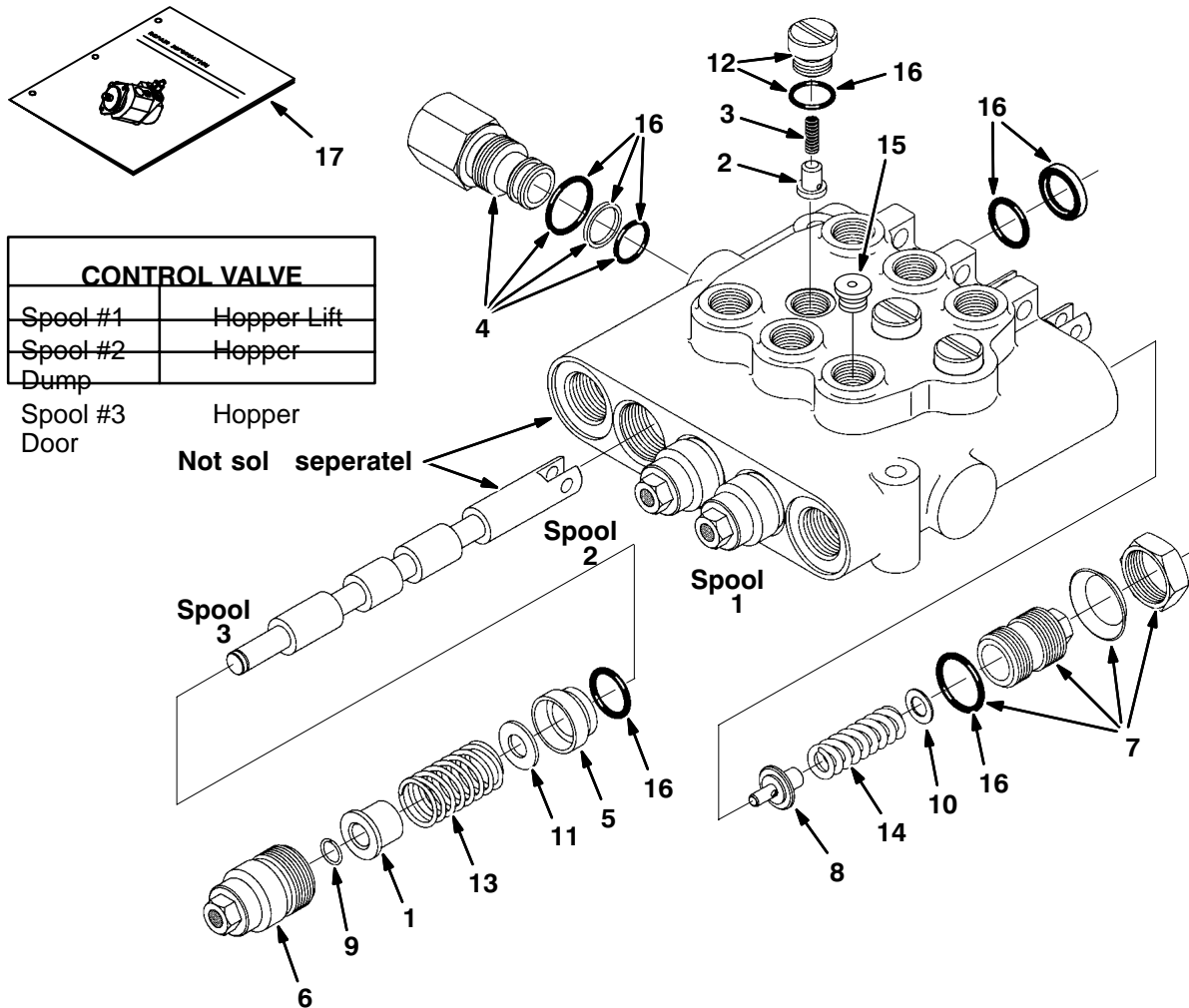

10407/10408,09670

Ref.	Tennant Part No.	Machine Serial Number	Description	Qty.
▽	77495	(000000—) Valve, Hyd Control Man	1
1	79822	(000000—) Spacer En	3
2	79786	(000000—) Plunger En	3
3	79787	(000000—) Spring En	3
4	79823	(000000—) Plug Assy,Byd En	1
5	79788	(000000—) Bushing En	3
6	79789	(000000—) Cap Assembly En	3
7	79790	(000000—) Plug Assembly En	1
8	79791	(000000—) Poppet En	1
9	79792	(000000—) Retaining Rng En	3
10	79793	(000000—) Shim .035 Thk En	1
10	79798	(000000—) Shim .015 Thk En	1
10	79799	(000000—) Shim .010 Thk En	1
11	79794	(000000—) Washer En	3
12	79795	(000000—) Plug & O-Ring En	3
13	79824	(000000—) Spring En	3
14	79797	(000000—) Spring En	1
15	13904	(000000—) Plug Gage #6	1
16	79812	(000000—) Seal Kit, Vlv En	1
17	79820	(000000—) Instr. Valve Repair Info	1

Fig. 26 – Hydraulic Manual Control Breakdown, 74285

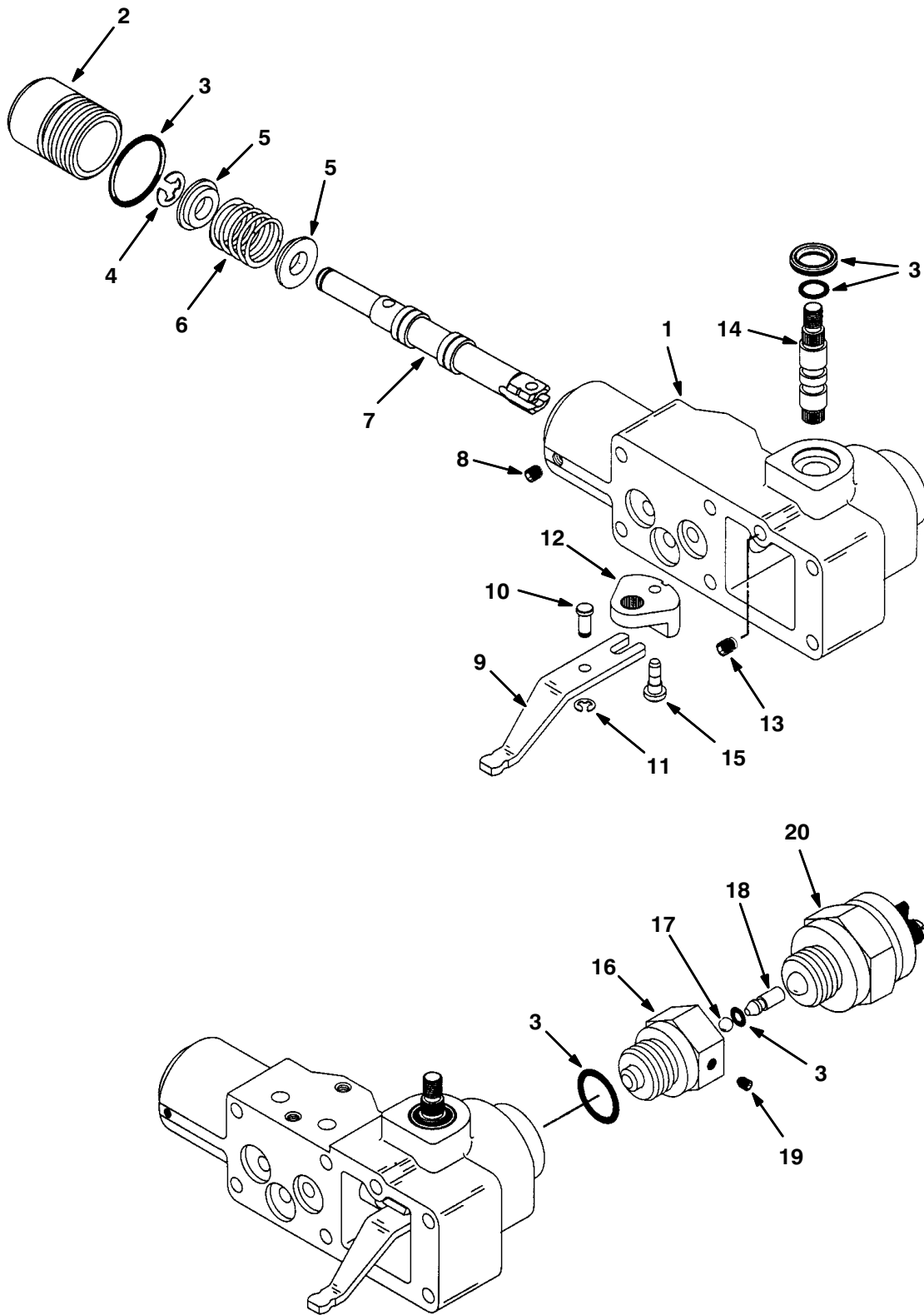

Fig. 26 – Hydraulic Manual Control Breakdown, 74285

Ref.	Tenant Part No.	Machine Serial Number	Description	Qty.
∇	74285	(000000–)	Manual Control En	1
1	79777	(000000–)	Housing,Control En	1
2	79755	(000000–)	Plug En	1
3	79776	(000000–)	Seal Kit,Cntrl En	1
4	79756	(000000–)	Ring, Retaining En	1
5	79757	(000000–)	Spring,Retainer En	2
6	79758	(000000–)	Spring, Cntr En	1
7	79772	(000000–)	Vlv Spool Wide En	1
8	79760	(000000–)	Screw, Set En	1
9	79761	(000000–)	Link, Feedback En	1
10	79762	(000000–)	Dowel Pin En	1
11	79763	(000000–)	Ring, Retaining En	1
12	79764	(000000–)	Bell Crank En	1
13	79765	(000000–)	Screw, Set En	1
14	79766	(000000–)	Shaft, Input En	1
15	79767	(000000–)	Pin, Headed En	1
16	79773	(000000–)	Adaptor,Neutral En	1
17	79774	(000000–)	Ball En	1
18	79778	(000000–)	Pin, Cntrl Assy En	1
19	79760	(000000–)	Screw, Set En	1
20	79775	(000000–)	Switch,Lockout En	1

Fig. 27 – Hydraulic Manual Control Breakdown, 74273

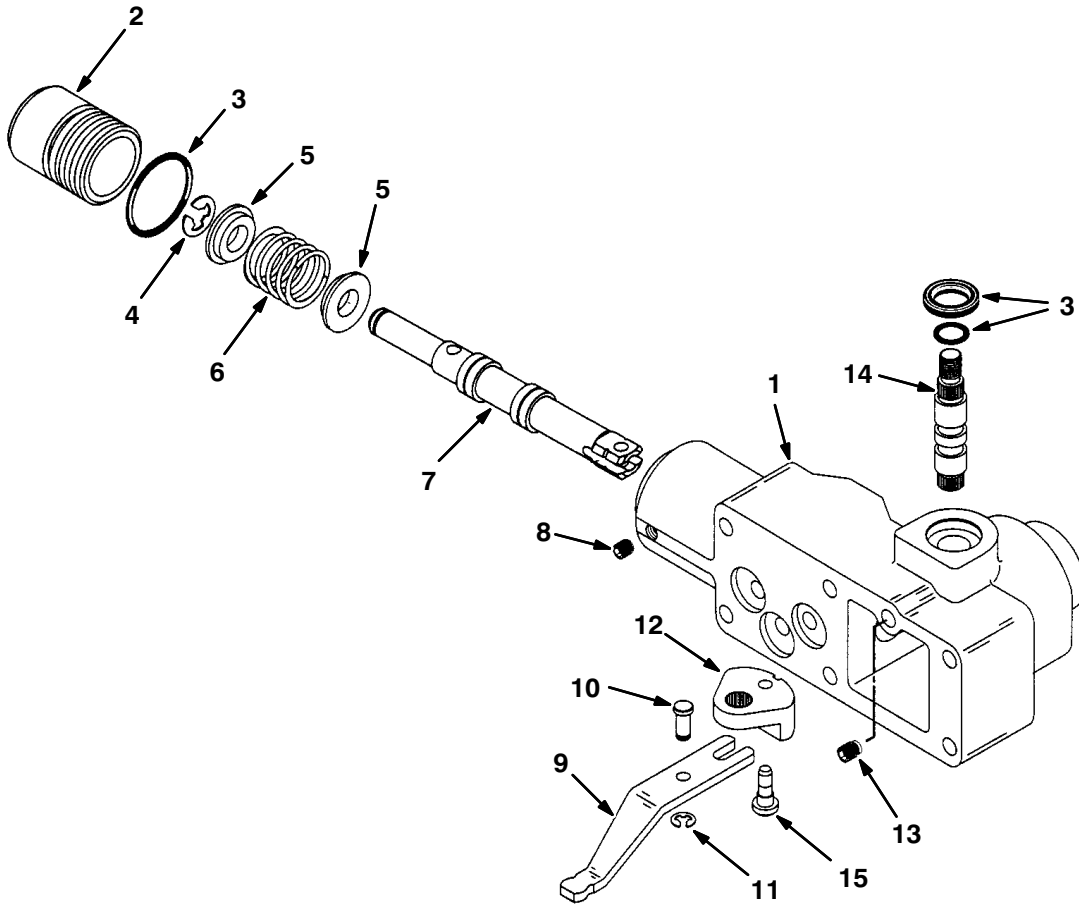
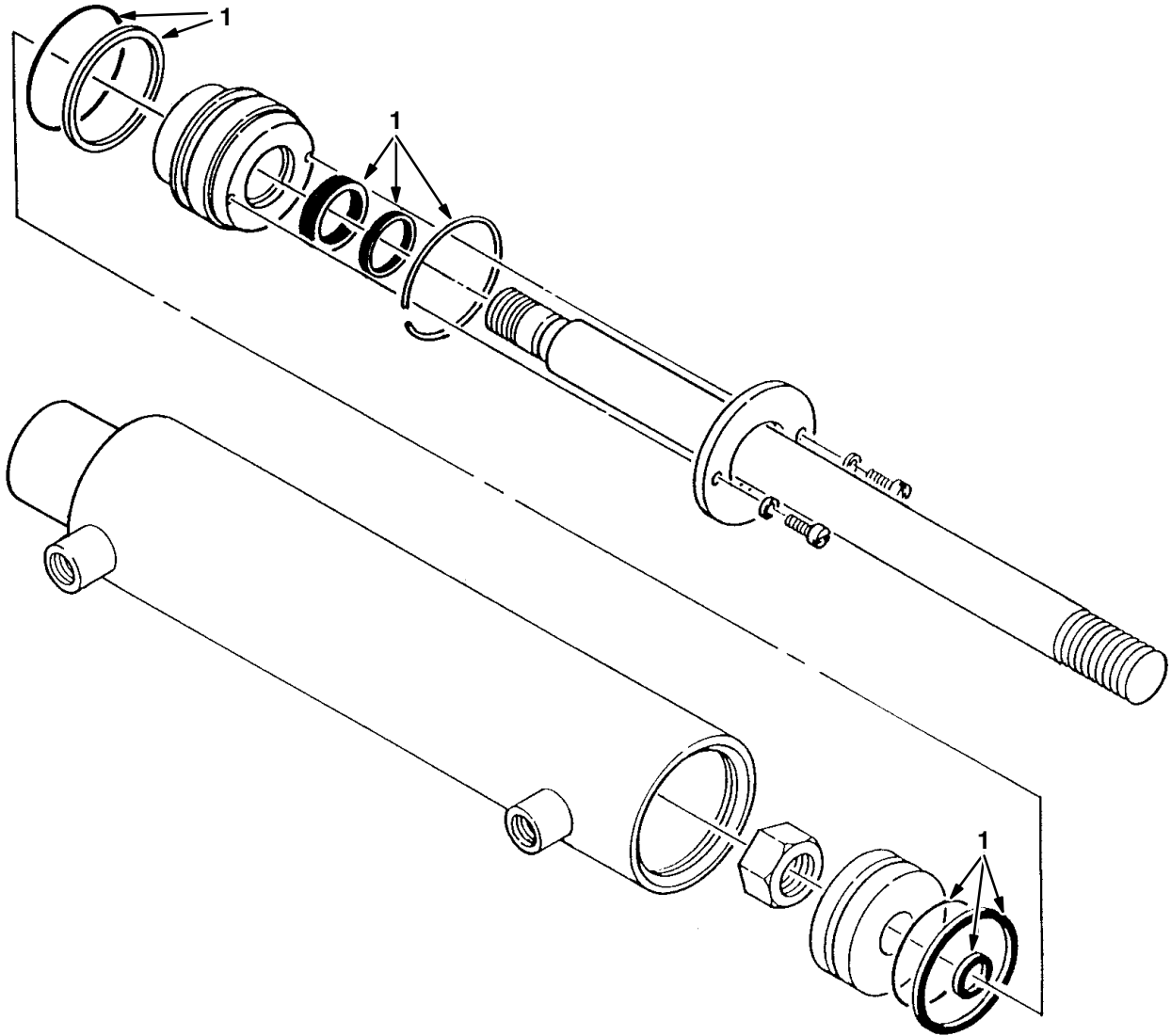

Fig. 27 – Hydraulic Manual Control Breakdown, 74273

Ref.	Tenant Part No.	Machine Serial Number	Description	Qty.
∇	74273	(000000–)	Control, Manual	1
1	79754	(000000–)	Housing,Control	1
2	79755	(000000–)	Plug	1
3	79776	(000000–)	Seal Kit,Cntrl	1
4	79756	(000000–)	Ring, Retaining	1
5	79757	(000000–)	Spring,Retainer	2
6	79758	(000000–)	Spring, Cntr	1
7	79759	(000000–)	Valve Spool	1
8	79760	(000000–)	Screw, Set	1
9	79761	(000000–)	Link, Feedback	1
10	79762	(000000–)	Dowel Pin	1
11	79763	(000000–)	Ring, Retaining	1
12	79764	(000000–)	Bell Crank	1
13	79765	(000000–)	Screw, Set	1
14	79766	(000000–)	Shaft, Input	1
15	79767	(000000–)	Pin, Headed	1

Fig. 28 – Hydraulic Cylinder Breakdown, 53601



07913/07494

Ref.	Tennant Part No.	Machine Serial Number	Description	Qty.
▽	53601	(000000–) Cylinder, Hydraulic	1
1	04483	(000000–) Seal Kit	1

Fig. 29 – Hydraulic Cylinder Breakdown, 62975

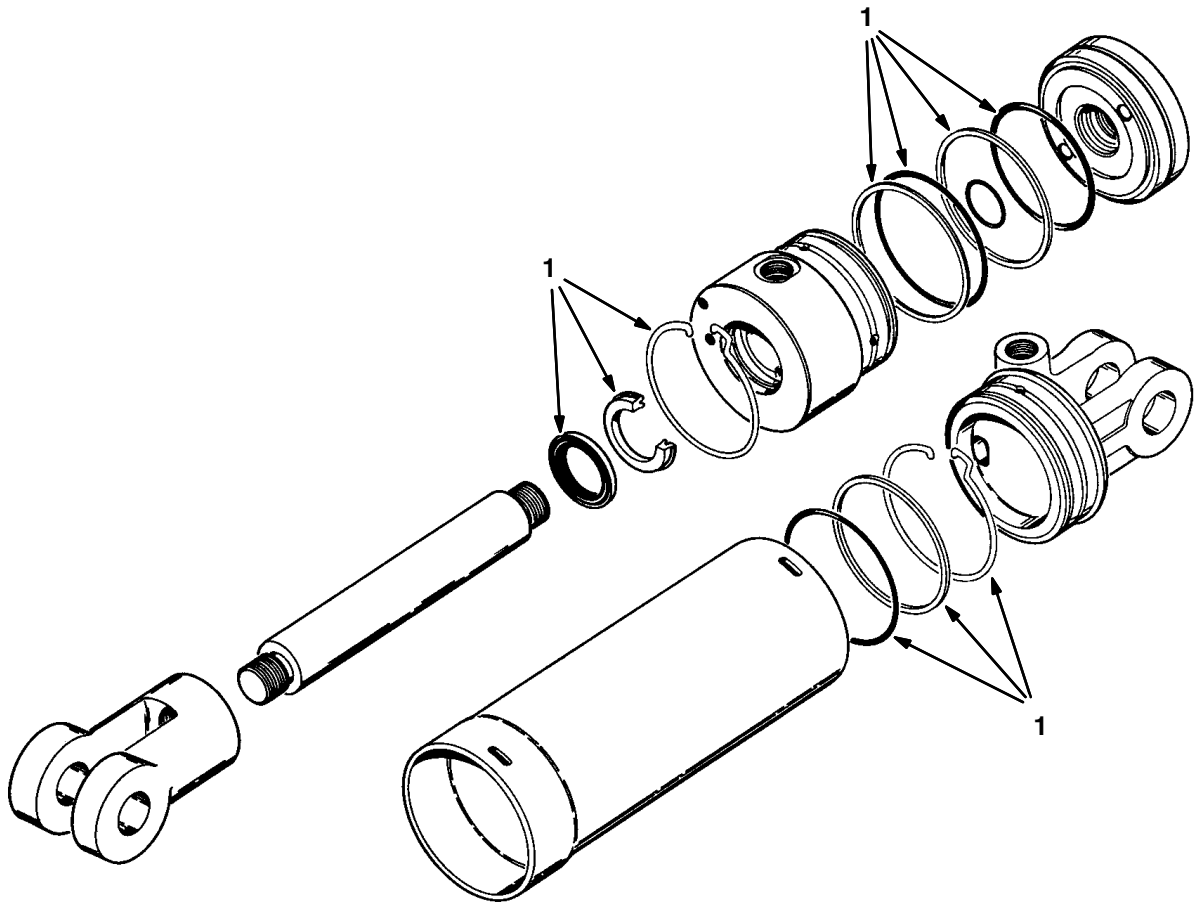

10403/10404

	Ref.	Tennant Part No.	Machine Serial Number	Description	Qty.
∇		62975	(000000–) Cylinder, Hyd 4.0B 14.5S 2500	1
1040422	1	79783	(000000–) Seal Kit, Cyl	1
	2	79784	(000000–) Repair Info,Cyl En	1

Fig. 30 – Air Conditioner Breakdown, 77675

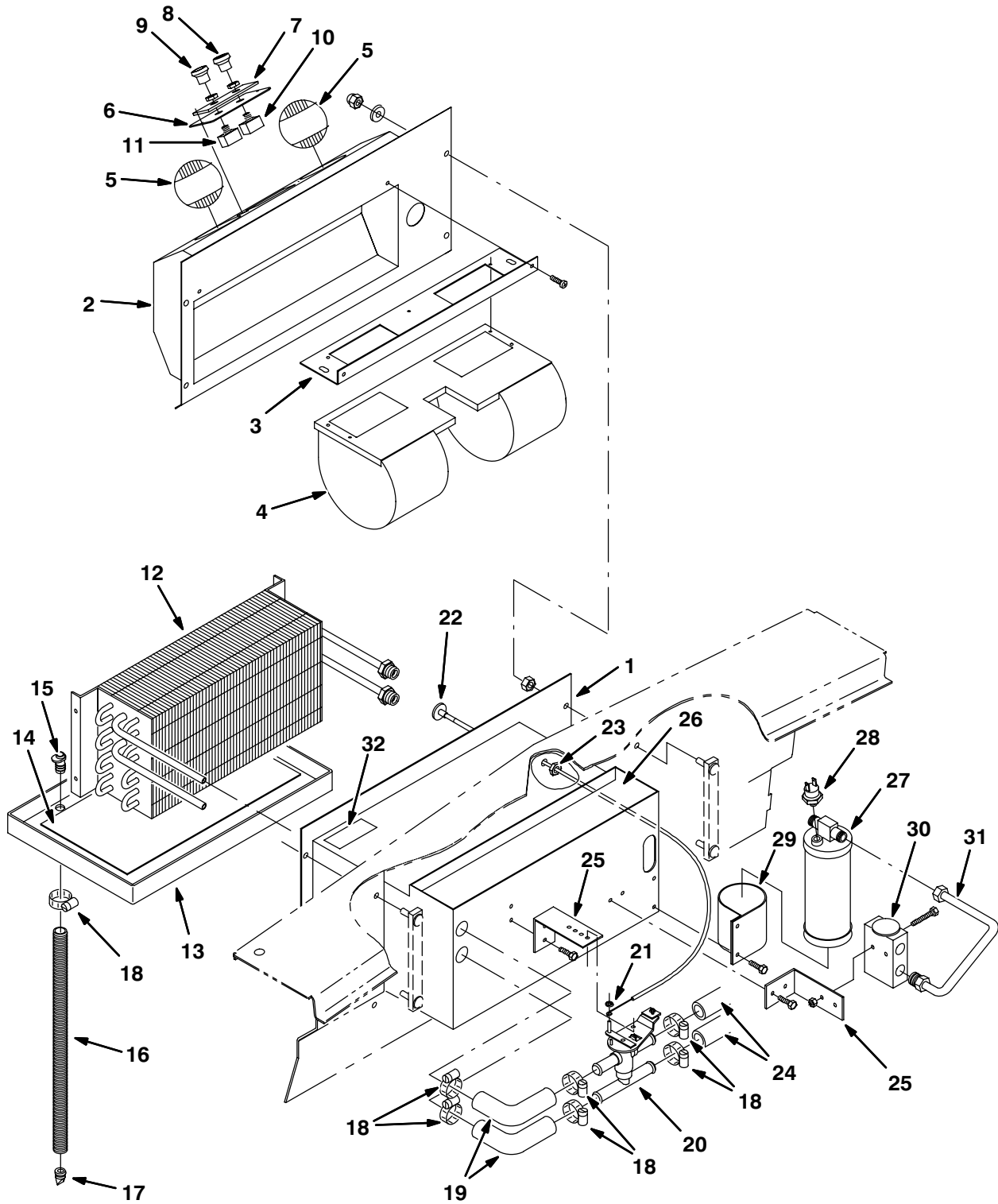

Fig. 30 – Air Conditioner Breakdown, 77675

Ref.	Tenant Part No.	Machine Serial Number	Description	Qty.
▽	77675	(000000–)	Air Conditioner, A 134 (Repl. by 21270)	1
1	77825	(000000–)	Box, A/C (Repl. by 21281)	1
2	77826	(000000–)	Case Front Cover (Repl. by 21281)	1
3	79688	(000000–)	Bracket, Blower Mount	1
4	55042	(000000–)	Blower	1
5	77827	(000000–)	Louver	2
6	79689	(000000–)	Bracket, Switch, A/C	1
7	77833	(000000–)	Face Plate Ac/Heat	1
8	77828	(000000–)	Knob, Fan	1
9	77829	(000000–)	Knob, Temp	1
10	77830	(000000–)	Switch, Blower	1
11	77831	(000000–)	Switch, Thermo	1
12	77839	(000000–)	Core, Heating/Cooling	1
13	77849	(000000–)	Drain Pan De	1
14	77848	(000000–)	Water Screen Foam De	1
15	79695	(000000–)	Drain Pan Tube De	2
16	77517	(000000–)	Hose, A/C Drain	2
17	79698	(000000–)	Valve, Check	2
18	77872	(000000–)	Hose Clamp De	8
19	77846	(000000–)	Hose Elbow 5/8 De	2
20	77841	(000000–)	Water Valve	1
21	77842	(000000–)	Valve, Push Nut Water	1
22	77835	(000000–)	Cable, Bowden	1
23	79692	(000000–)	Jamb Nut 7/16 Hex De	1
24	32151	(000000–)	Heater Hose 72In De	2
25	79694	(000000–)	Valve Mountng Brkt De	2
26	77847	(000000–)	Foam Case Insul De	1
27	77843	(000000–)	Dryer	1
28	77844	(000000–)	Binary Press. Switch	1
29	77845	(000000–)	Dryer Bracket De	1
30	77840	(000000–)	Explansion Block	1
31	79697	(000000–)	Alum.Dryer Line De	1
32	79699	(000000–)	Decal	1
	77832	(000000–)	Wire Harness	1

Fig. 31 – Air Conditioner Breakdown, 21270

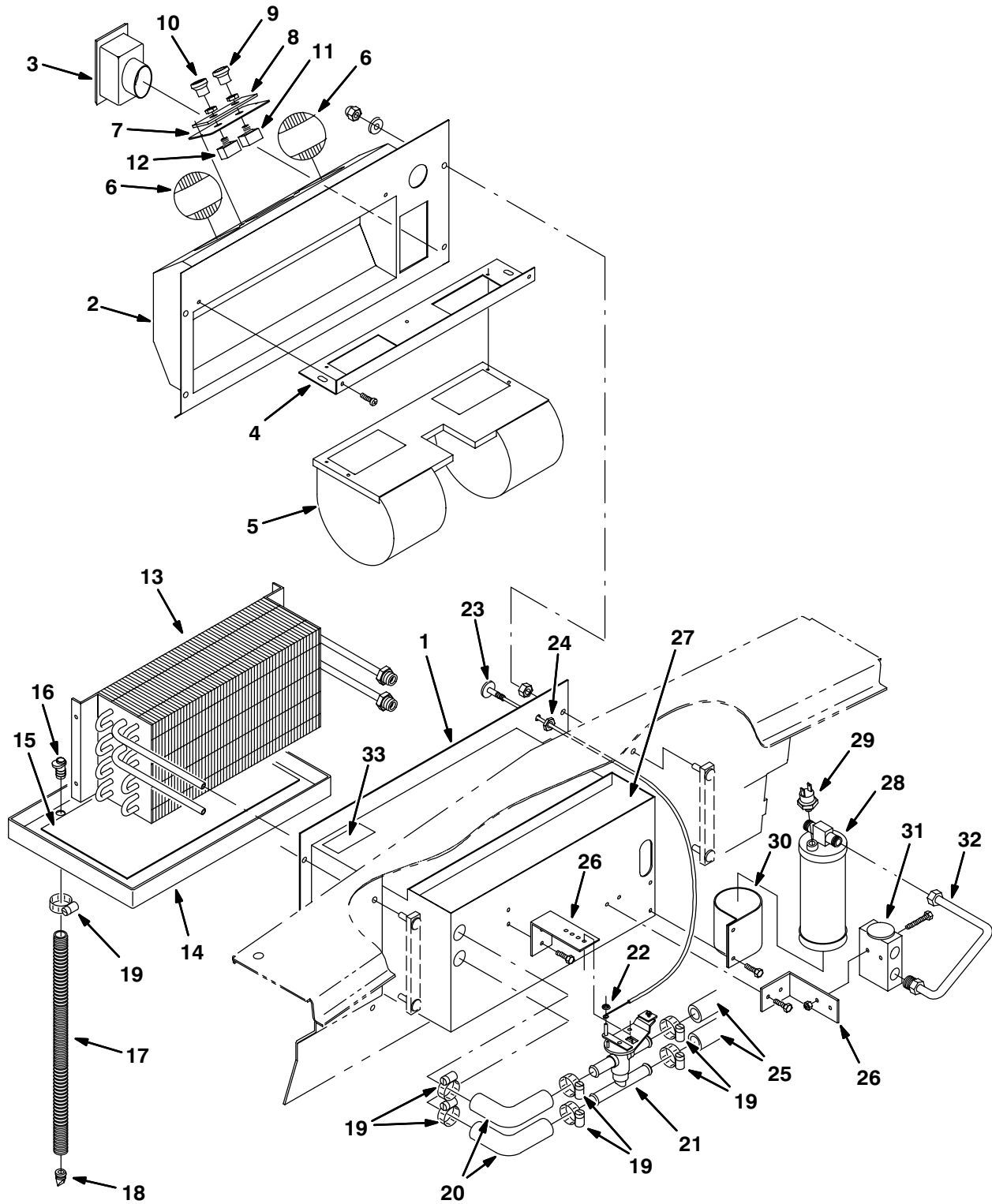

Fig. 31 – Air Conditioner Breakdown, 21270

Ref.	Tenant Part No.	Machine Serial Number	Description	Qty.
∇	21270	(000000–)	Air Conditioner 134R Recirc	1
1	21279	(000000–)	Box, A/C	1
2	21280	(000000–)	Cover, A/C	1
3	21272	(000000–)	Louver, Recirc	1
4	79688	(000000–)	Bracket, Blower Mount	1
5	55042	(000000–)	Blower	1
6	77827	(000000–)	Louver	2
7	79689	(000000–)	Bracket, Switch, A/C	1
8	77833	(000000–)	Face Plate Ac/Heat	1
9	77828	(000000–)	Knob, Fan	1
10	77829	(000000–)	Knob, Temp	1
11	77830	(000000–)	Switch, Blower	1
12	77831	(000000–)	Switch, Thermo	1
13	77839	(000000–)	Core, Heating/Cooling	1
14	77849	(000000–)	Drain Pan De	1
15	77848	(000000–)	Water Screen Foam De	1
16	79695	(000000–)	Drain Pan Tube De	2
17	77517	(000000–)	Hose, A/C Drain	2
18	79698	(000000–)	Valve, Check	2
19	77872	(000000–)	Hose Clamp De	8
20	77846	(000000–)	Hose Elbow 5/8 De	2
21	77841	(000000–)	Water Valve	1
22	77842	(000000–)	Valve, Push Nut Water	1
23	77835	(000000–)	Cable, Bowden	1
24	79692	(000000–)	Jamb Nut 7/16 Hex De	1
25	32151	(000000–)	Heater Hose 72In De	2
26	79694	(000000–)	Valve Mountng Brkt De	2
27	77847	(000000–)	Foam Case Insul De	1
28	77843	(000000–)	Dryer	1
29	77844	(000000–)	Binary Press. Switch	1
30	77845	(000000–)	Dryer Bracket De	1
31	77840	(000000–)	Expansion Block	1
32	79697	(000000–)	Alum.Dryer Line De	1
33	79699	(000000–)	Decal	1
	77832	(000000–)	Wire Harness	1

Fig. 32 – Heater/Pressurizer Breakdown, 74091

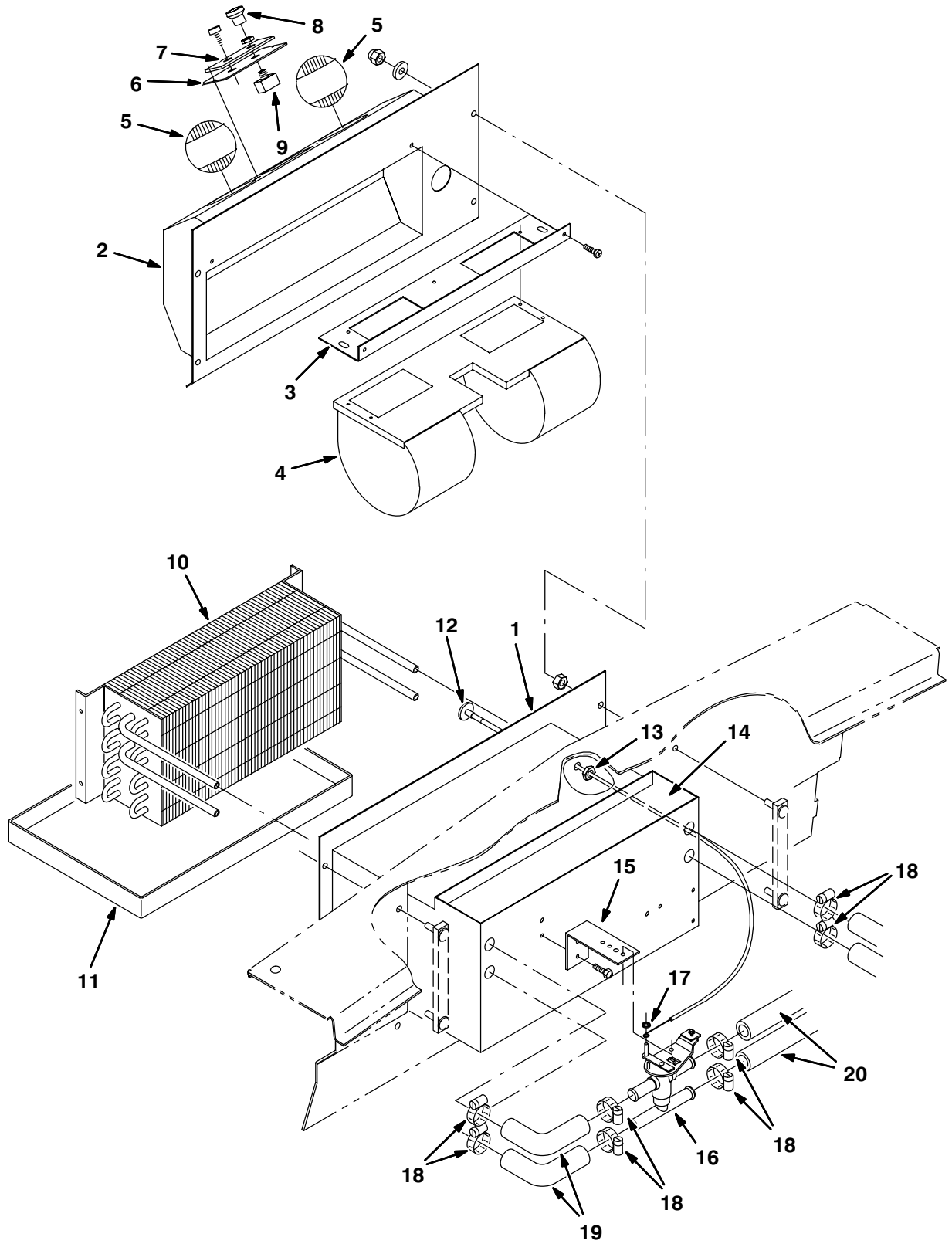

Fig. 32 – Heater/Pressurizer Breakdown, 74091

Ref.	Tenant Part No.	Machine Serial Number	Description	Qty.
▽	74091	(000000–)	Heater, Pressurizer (Repl. by 21271)	1
1	77825	(000000–)	Box, A/C	1
2	77826	(000000–)	Case Front Cover	1
3	79688	(000000–)	Bracket, Blower Mount	1
4	55042	(000000–)	Blower	1
5	77827	(000000–)	Louver	2
6	79690	(000000–)	Switch Brkt Heat De	1
7	77834	(000000–)	Face Plate Heat De	1
8	77828	(000000–)	Knob, Fan	1
9	77830	(000000–)	Switch, Blower	1
10	77839	(000000–)	Core, Heating/Cooling	1
11	77849	(000000–)	Drain Pan De	1
12	77835	(000000–)	Cable, Bowden	1
13	79692	(000000–)	Jamb Nut 7/16 Hex De	1
14	77847	(000000–)	Foam Case Insul De	1
15	79694	(000000–)	Valve Mountng Brkt De	1
16	77841	(000000–)	Water Valve	1
17	77842	(000000–)	Valve, Push Nut Water	1
18	77872	(000000–)	Hose Clamp De	8
19	77846	(000000–)	Hose Elbow 5/8 De	2
20	32151	(000000–)	Heater Hose 72In De	2
	77832	(000000–)	Wire Harness	1

Fig. 33 – Heater/Pressurizer Breakdown, 21271

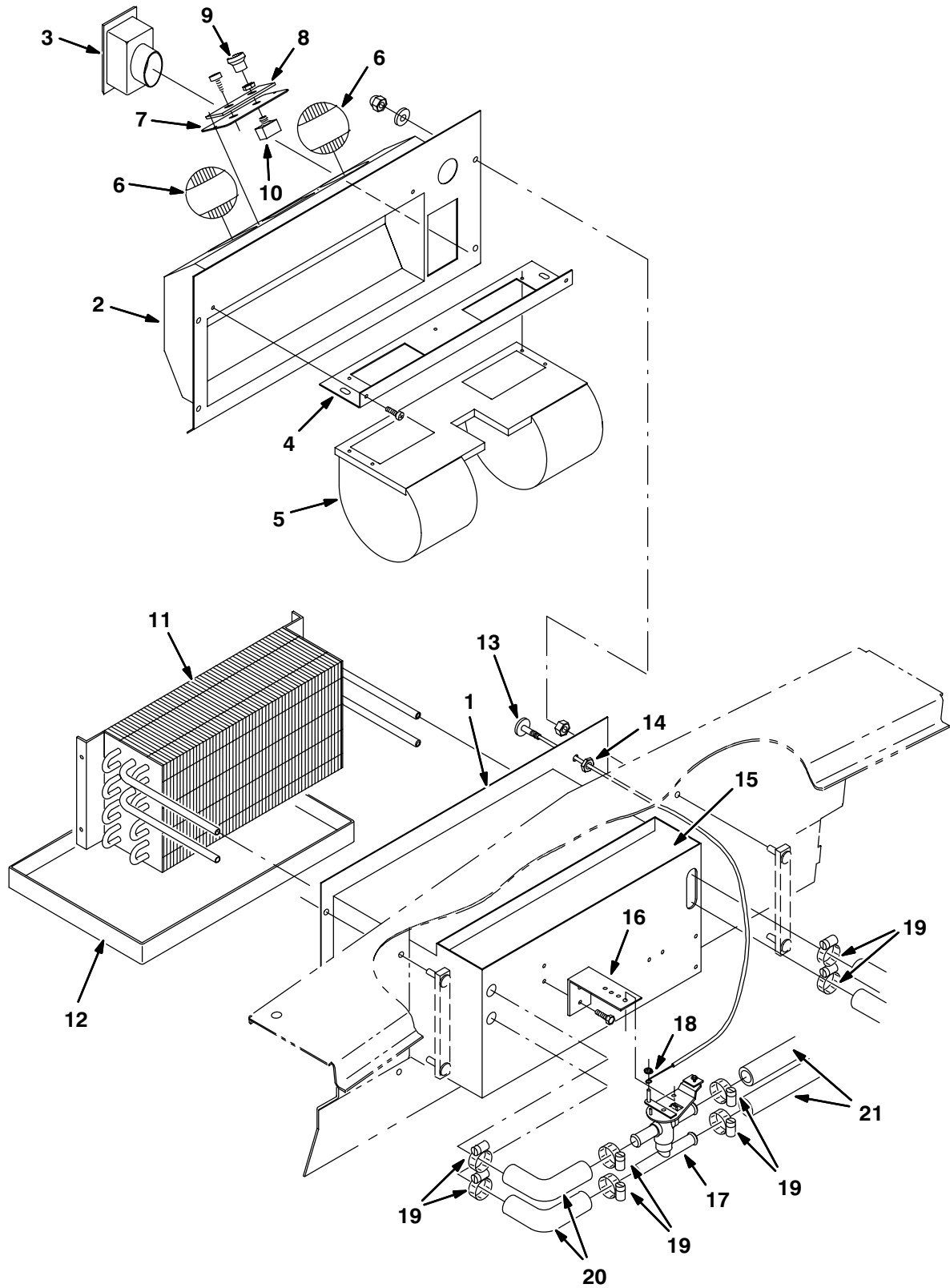

Fig. 33 – Heater/Pressurizer Breakdown, 21271

Ref.	Tenant Part No.	Machine Serial Number	Description	Qty.
∇	21271	(000000–)	Heater, Pressurizer	1
1	21279	(000000–)	Box, A/C	1
2	21280	(000000–)	Cover, A/C	1
3	21272	(000000–)	Louver, Recirc	1
4	79688	(000000–)	Bracket, Blower Mount	1
5	55042	(000000–)	Blower	1
6	77827	(000000–)	Louver	2
7	79690	(000000–)	Switch Brkt Heat De	1
8	77834	(000000–)	Face Plate Heat De	1
9	77828	(000000–)	Knob, Fan	1
10	77830	(000000–)	Switch, Blower	1
11	77839	(000000–)	Core, Heating/Cooling	1
12	77849	(000000–)	Drain Pan De	1
13	77835	(000000–)	Cable, Bowden	1
14	79692	(000000–)	Jamb Nut 7/16 Hex De	1
15	77847	(000000–)	Foam Case Insul De	1
16	79694	(000000–)	Valve Mountng Brkt De	1
17	77841	(000000–)	Water Valve	1
18	77842	(000000–)	Valve, Push Nut Water	1
19	77872	(000000–)	Hose Clamp De	8
20	77846	(000000–)	Hose Elbow 5/8 De	2
21	32151	(000000–)	Heater Hose 72In De	2
	77832	(000000–)	Wire Harness	1

SECTION 5**CONTENTS**

	PAGE
Fig. 1 – Cylinder Head and Cover Group	5-2
Fig. 2 – Cylinder Block Group	5-4
Fig. 3 – Oil Pan and Timing Cover Group	5-6
Fig. 4 – Piston, Crankshaft and Flywheel Group	5-8
Fig. 5 – Valve Group	5-10
Fig. 6 – Inlet Manifold Group	5-12
Fig. 7 – Exhaust Manifold Group	5-13
Fig. 8 – Fuel Supply Group	5-14
Fig. 9 – Fuel Filter Group	5-16
Fig. 10 – Water Pump Group	5-17
Fig. 11 – Oil Pump and Filter Group	5-18
Fig. 12 – Starter Group	5-20
Fig. 13 – Glow Plug Group	5-22
Fig. 14 – Temperature Gauge Group	5-23

Fig. 1 – Cylinder Head and Cover Group

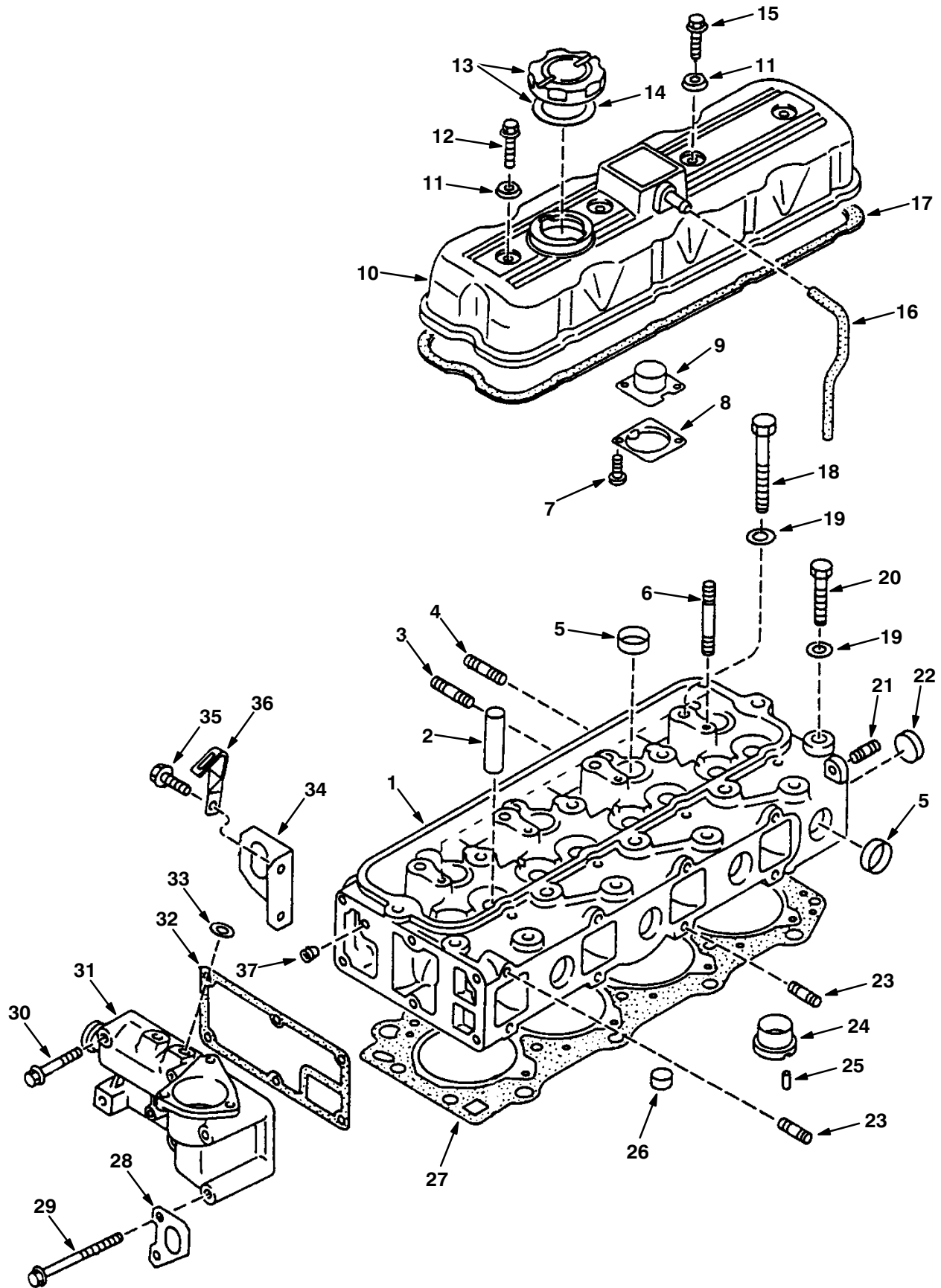

Fig. 1 – Cylinder Head and Cover Group

Ref.	Tennant Part No.	Perkins Part Number	Description	Qty.
1	74734	S501-10-100J	Head, Cylinder	1
2	74857	TF01-10-281A	Guide, Valve	8
3	74681	99789-0825A	Stud	1
4	74682	99789-0845A	Stud	1
5	74657	99306-3000	Plug	2
6	74683	99789-0848	Stud	1
7	74718	99868-0408	Bolt	1
8	74810	SE08-10-229	Plate, Oil Baffle	1
9	74809	SE08-10-227	Plate, Baffle	1
10	74761	SE01-10-2208	Cover, Cylinder Head	1
11	74601	1456-10-237	Washer, Sealing	4
12	74687	99796-0816	Bolt	2
∇ 13	74572	0453-10-250A	Cap, Oil Filler	1
14	74570	0324-10-252	Gasket	1
15	74691	99796-0840	Bolt	2
16	74763	SE01-10-255	Hose, Breather	1
17	74762	SE01-10-235A	Gasket, Head Cover	1
18	74758	SE01-10-137	Bolt, Cylinder Head	7
19	74759	SE01-10-138	Washer, Plain	18
20	74757	SE01-10-136	Bolt, Cylinder Head	11
21	74717	99859-1016F	Stud	1
22	74659	99306-4950	Stud	1
23	74711	99852-0818A	Stud	2
24	74735	S501-10-111B	Insert	4
25	74643	99222-0308	Pin	4
26	74859	99306-2500	Plug	3
27	74736	S501-10-271	Gasket, Cylinder Head	1
28	74767	SE01-10-561	Hanger, Engine	1
29	74704	99796-1095	Bolt	2
30	74692	99796-0845	Bolt	4
31	74816	SE70-10-150	Casing, Thermostat	1
32	74854	SLM1-10-153	Plug, Thermostat Case	1
33	74564	0110-18-515	O-Ring	1
34	74768	SE01-10-562	Hanger, Engine, Front	1
35	74699	99796-1020	Bolt	2
36	74571	0370-39-025A	Clip	1
37	74662	99503-1000J	Plug	1

Fig. 2 – Cylinder Block Group

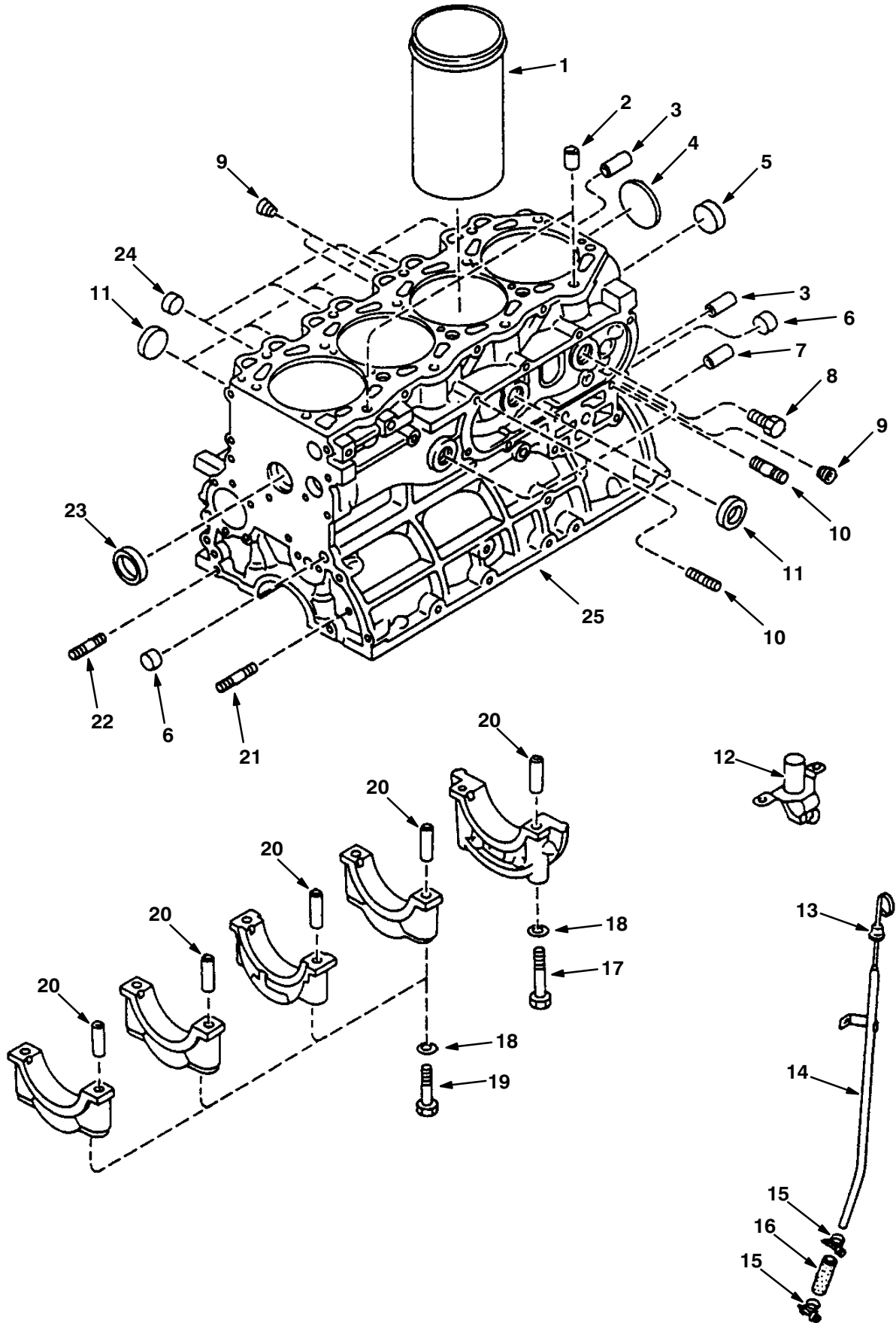

Fig. 2 – Cylinder Block Group

Ref.	Tennant Part No.	Perkins Part Number	Description	Qty.
1	74742	S501-23-051	Liner, Cylinder	4
2	74650	99234-1618	Dowel	2
3	74647	99233-1228	Dowel	2
4	74579	0636-10-303	Plug, Camshaft	1
5	74657	99306-3000	Plug	1
6	74567	0221-10-327	Plug, Blind	3
7	74644	99233-0616	Dowel	2
8	74573	0488-10-321	Plug	1
9	74662	99503-1000J	Plug	1
10	74714	99852-0840	Stud	2
11	74657	99306-3000	Plug	8
12	74846	SL70-10-33X	Pipe, Seal	1
13	74822	SEA1-10-450	Gage, Oil Level	1
14	74766	SE01-10-460B	Pipe, Oil Gage	1
15	74655	99283-1500	Clamp	2
16	74730	RF01-10-454	Holder, Oil Gage	1
17	74765	SE01-10-372	Bolt	2
18	74759	SE01-10-138	Washer, Plain	10
19	74764	SE01-10-352	Bolt, Bearing Cap	8
20	74566	0221-10-308	Pin, Tubular	10
21	74712	99852-0822	Stud	1
22	74715	99852-0868	Stud	1
23	74658	99306-4000	Plug	1
24	74859	99306-2500	Plug	3
25	74748	S5A1-02-200A	Shortblock	1
25	74746	S535-10-300B	Block, Cylinder	1

Fig. 3 – Oil Pan and Timing Cover Group

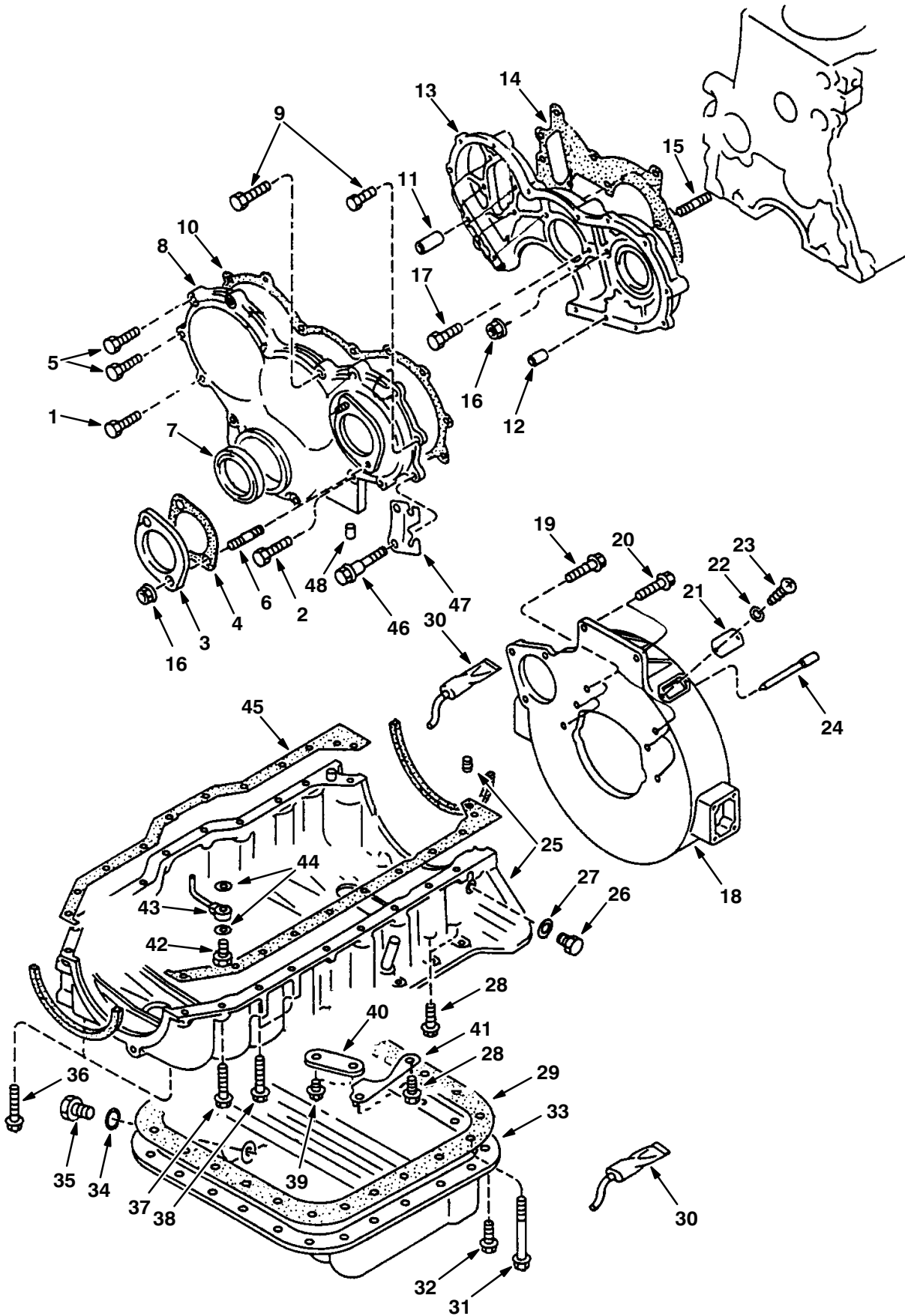

Fig. 3 – Oil Pan and Timing Cover Group

Ref.	Tennant Part No.	Perkins Part Number	Description	Qty.
1	74695	99796-0865	Bolt	1
2	74696	99796-0870	Bolt	2
3	74580	0636-10-701A	Cover, Injection Pump	1
4	74581	0636-10-711	Gasket, Gear Cover	1
5	74705	99796-0830	Bolt	4
6	74710	99852-0812G	Stud	2
7	74831	SEM1-10-602	Seal, Oil	1
8	74832	SEM1-10-650	Cover, Timing Gear	1
9	74694	99796-0855	Bolt	5
10	74815	SE11-10-653	Gasket, Timing Cover	1
11	74648	99234-0855	Sleeve	1
12	74649	99234-1212	Sleeve	1
13	74818	SE70-10-600A	Case, Timing Gear	1
14	74814	SE11-10-603	Gasket, Timing Case	1
15	74713	99852-0825G	Stud	2
16	74721	99940-0801	Nut	4
17	74688	99796-0820	Bolt	6
18	74612	4793-10-RROA	Housing, Flywheel	1
19	74701	99796-1035	Bolt	6
20	74700	99796-1028	Bolt	2
21	74578	0613-16-111	Cover, Peep Hole	1
22	74725	99971-0500	Washer	2
23	74716	99853-0510	Bolt	2
24	74622	4890-10-902A	Pin, Top Indicator	1
25	74821	SEA1-10-380C	Block, Oil Pan Upper	1
26	74666	99511-1200	Bolt	1
27	74669	99564-1200	Washer	1
28	74707	99800-08110	Bolt	4
29	74808	SE01-23-099	Gasket, Oil Pan	1
30	74625	8527-77-739	Tube, Silicone	2
31	74708	99800-08120	Bolt	2
32	74706	997967-0812	Bolt	20
▽ 33	74608	4782-10-400A	Pan, Oil	1
34	74670	99564-1400	Washer	1
35	74727	HE03-10-404	Plug, Drain	1
36	74709	99800-08130	Bolt	2
37	74689	99796-0825	Bolt	11
38	74693	99796-0850	Bolt	5
39	74688	99796-0820	Bolt	2
40	74853	SLA11425X	Bracket, Oil Strainer	1
41	74820	SE70-14-268	Bracket, Oil Pipe	1
42	74771	SE01-10-730	Valve, Oil Jet	4
43	74769	SE01-10-710	Jet, Oil	4
44	74770	SE01-10-715	Gasket, Oil Jet	8
45	75739	8AW4-10-431	Gasket, Oil Pan	1
46	74690	99796-0830	Bolt	2
47	74793	SE01-13-786C	Bracket, Accel Cable	1
48	74645	99233-0818	Pin	2

Fig. 4 – Piston, Crankshaft and Flywheel Group

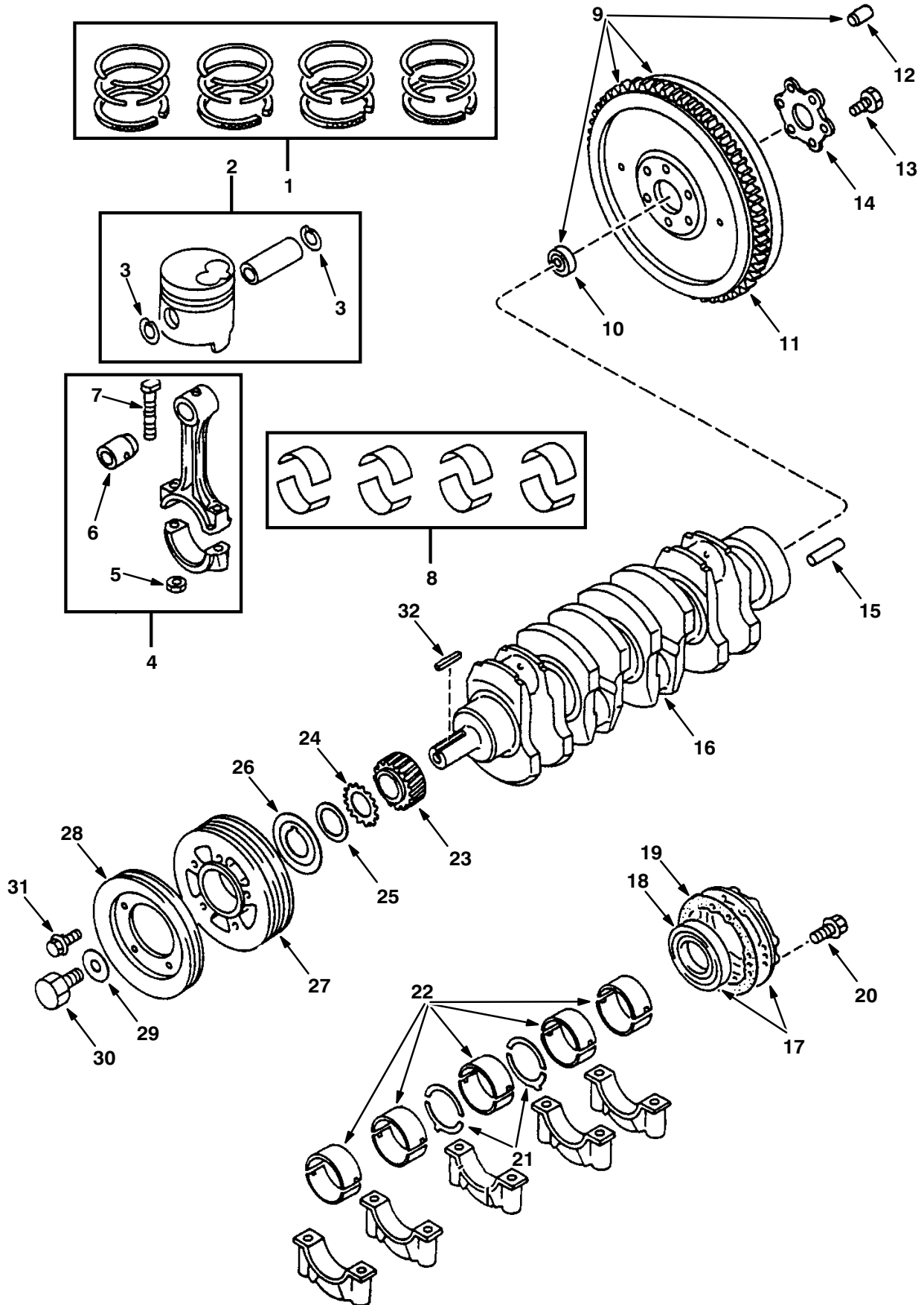

Fig. 4 – Piston, Crankshaft and Flywheel Group

Ref.	Tennant Part No.	Perkins Part Number	Description	Qty.
1	74598	0911-23-206	Ring Set, Piston	1
∇ 2	74743	S501-23-200A	Piston Set	4
3	74602	1456-11-202	Ring, Retaining	8
∇ 4	74737	S501-11-210	Rod, Connecting	4
5	74772	SE01-11-215	Nut, Connecting Rod	8
6	74738	S501-11-213	Bushing, Connecting Rod	4
7	74563	01-11-214	Bolt, Connecting Rod	8
8	74574	0527-23-105	Metal Set, Connecting Rod	1
8	74575	0527-23-106	Metal Set, Connecting Rod OS 0.254	1
8	74576	0527-23-107	Metal Set, Connecting Rod OS 0.508	1
8	74577	0527-23-108	Metal Set, Connecting Rod OS 0.762	1
∇ 9	74614	4810-11-500B	Flywheel	1
10	74675	99606-22020	Bearing, Flywheel	1
11	74624	4892-11-502	Gear, Ring	1
12	74621	4882-11-504	Pin, Knock	2
13	74843	SL02-11-511G	Bolt, Lock, Flywheel	6
14	74837	SL01-11-513	Washer	1
15	74646	99233-0822	Pin	3
16	74744	S515-11-301	Crankshaft	1
∇ 17	74855	SLM1-11-310	Cover, Rear	1
18	74833	SEM1-11-399	Seal, Oil	1
19	74856	SLM1-11-318	Gasket, Rear Cover	1
20	74690	99796-0830	Bolt	8
21	74592	0636-23-115	Metal Set, Thrust	1
21	74593	0636-23-116	Metal Set, Thrust OS	1
22	74750	S5A1-23-110	Metal Set, Main Bearing	1
22	74751	S5A1-23-111	Metal Set, Main Bearing OS 0.254	1
22	74752	S5A1-23-112	Metal Set, Main Bearing OS 0.508	1
22	74753	S5A1-23-113	Metal Set, Main Bearing OS 0.762	1
23	74823	SEA1-11-32X	Gear, Crankshaft	1
24	74733	S234-11-327	Gear, Friction	1
25	74732	S234-11-323	Spring, Friction Gear	1
26	74847	SL70-11-315	Plate, Baffle	1
27	74824	SEA1-11-401A	Pulley, Crankshaft	1
28	74775	SE01-11-402	Pulley	1
29	74774	SE01-11-377A	Washer, Plain	1
30	74773	SE01-11-376A	Bolt, Pulley	1
31	74680	99784-0812	Bolt	5
32	74651	99236-0545	Key, Woodruff	1

Fig. 5 – Valve Group

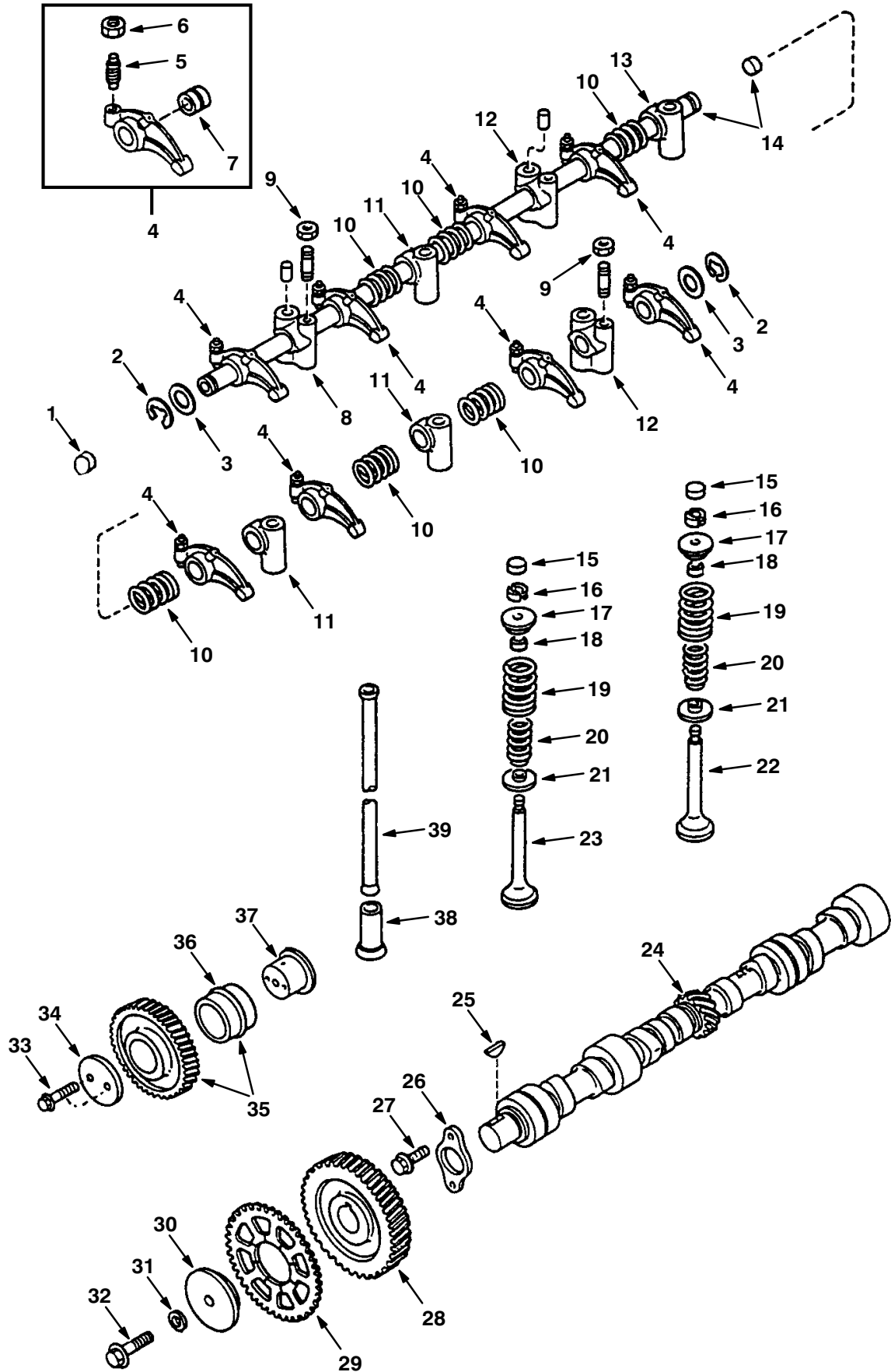
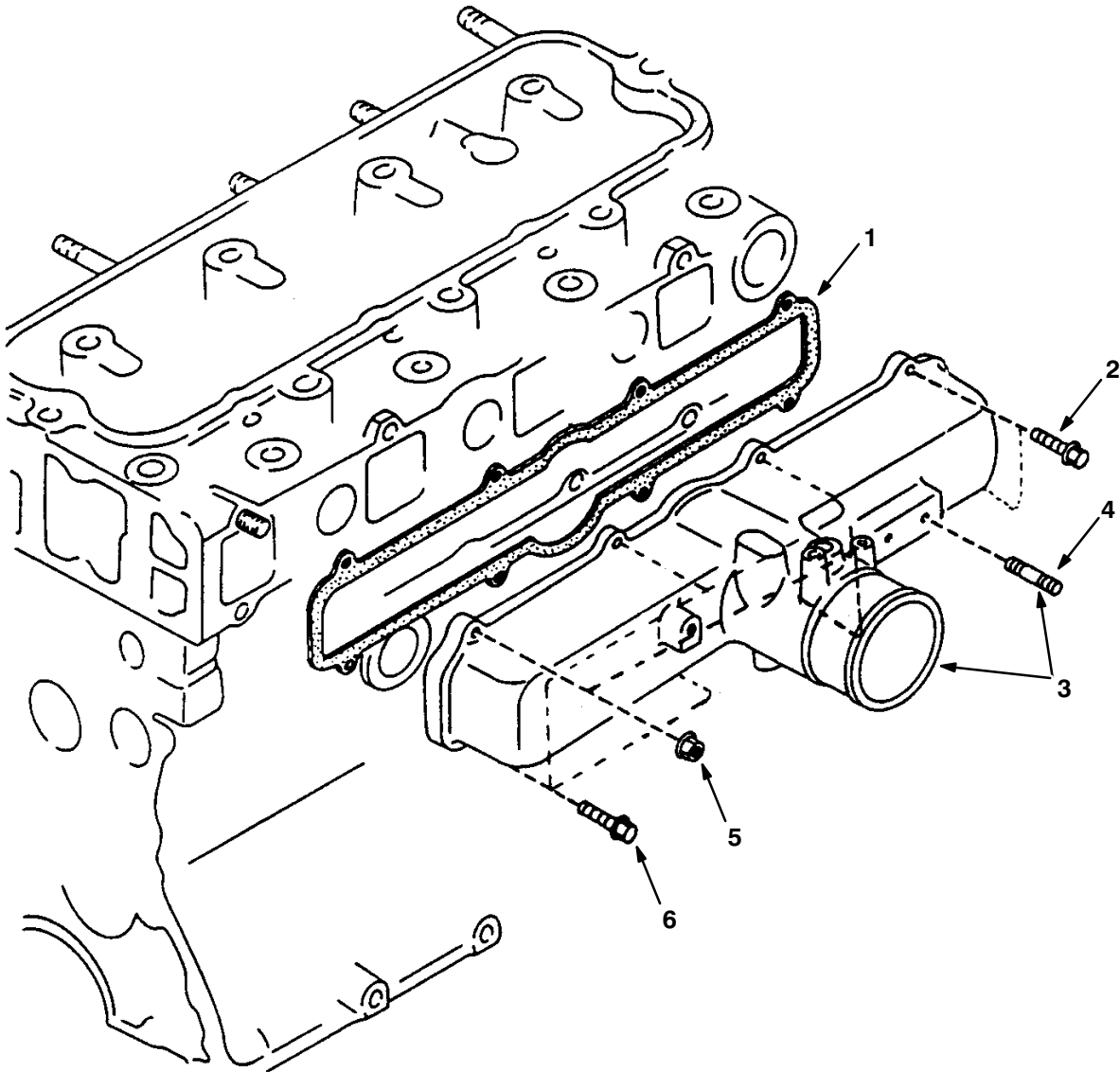

Fig. 5 – Valve Group

	Ref.	Tennant Part No.	Perkins Part Number	Description	Qty.
764524	1	74656	99306-1000	Plug, Rocker Arm	2
	2	74674	99576-1200	Ring, Retaining	2
	3	74584	0636-12-168A	Washer	2
∇	4	74780	SE01-12-130	Arm, Rocker	8
	5	74781	SE01-12-133	Screw, Tappet Adjusting	8
	6	74719	99922-0800	Nut	1
	7	74623	4891-12-132A	Bushing, Rocker Arm	8
	8	74784	SE01-12-171A	Bracket, Rocker	1
	9	74787	SE01-12-181	Nut	2
	10	74583	0636-12-166	Spring, Rocker Arm	6
	11	74783	SE01-12-164	Bracket, Rocker Arm	3
	12	74785	SE01-12-172	Bracket, Rocker Arm	2
	13	74786	SE01-12-173	Bracket, Rocker Arm	1
	14	74782	SE01-12-160	Shaft, Rocker Arm	1
	15	74779	SE01-12-118	Cap, Valve	8
	16	75731	TF01-12-114	Cotter, Valve	16
	17	74776	SE01-12-112	Seat, Valve Spring Upper	8
	18	74760	SE01-10-155A	Seal, Valve	4
	18	74817	SE70-10-155A	Seal, Valve	4
	19	74777	SE01-12-114	Spring, Exhaust Valve	8
	20	74582	0636-12-115	Spring, Valve Intake	8
	21	74778	SE01-12-116	Seat, Valve Spring Lower	8
	22	74739	S501-12-111	Valve, Intake	4
	23	74747	S535-12-121	Valve, Exhaust	4
	24	74819	SE70-12-421	Camshaft	1
	25	74587	0636-12-412	Key, Woodruff	1
	26	74588	0636-12-422A	Plate, Thrust	1
	27	74687	99796-0816	Bolt	2
	28	74826	SEA1-12-411B	Gear, Cam	1
	29	74604	1456-12-418	Gear, Friction	1
	30	74603	1456-12-414A	Washer, Lock	1
	31	74724	99958-1220	Washer	1
	32	74679	99781-1235	Bolt	1
	33	74693	99796-0850	Bolt	2
	34	74586	0636-12-404	Plate, Thrust	1
∇	35	74825	SEA1-12-400B	Gear, Idle	1
	36	74585	0636-12-401A	Bushing, Idle Gear	1
	37	74848	SL70-12-403	Spindle, Idle Gear	1
	38	74589	0636-12-431A	Tappet	8
	39	74788	SE01-12-310	Rod, Push	8

Fig. 6 – Inlet Manifold Group



07700/07701

Ref.	Tennant Part No.	Perkins Part Number	Description	Qty.
1	74834	SEM1-13-111	Gasket, Intake Manifold	1
2	74689	99796-0825	Bolt	2
∇ 3	74611	4783-13-100	Manifold, Intake	1
4	74838	SL01-13-104	Stud	2
5	74721	99940-0801	Nut	2
6	74688	99796-0820	Bolt	4

Fig. 7 – Exhaust Manifold Group

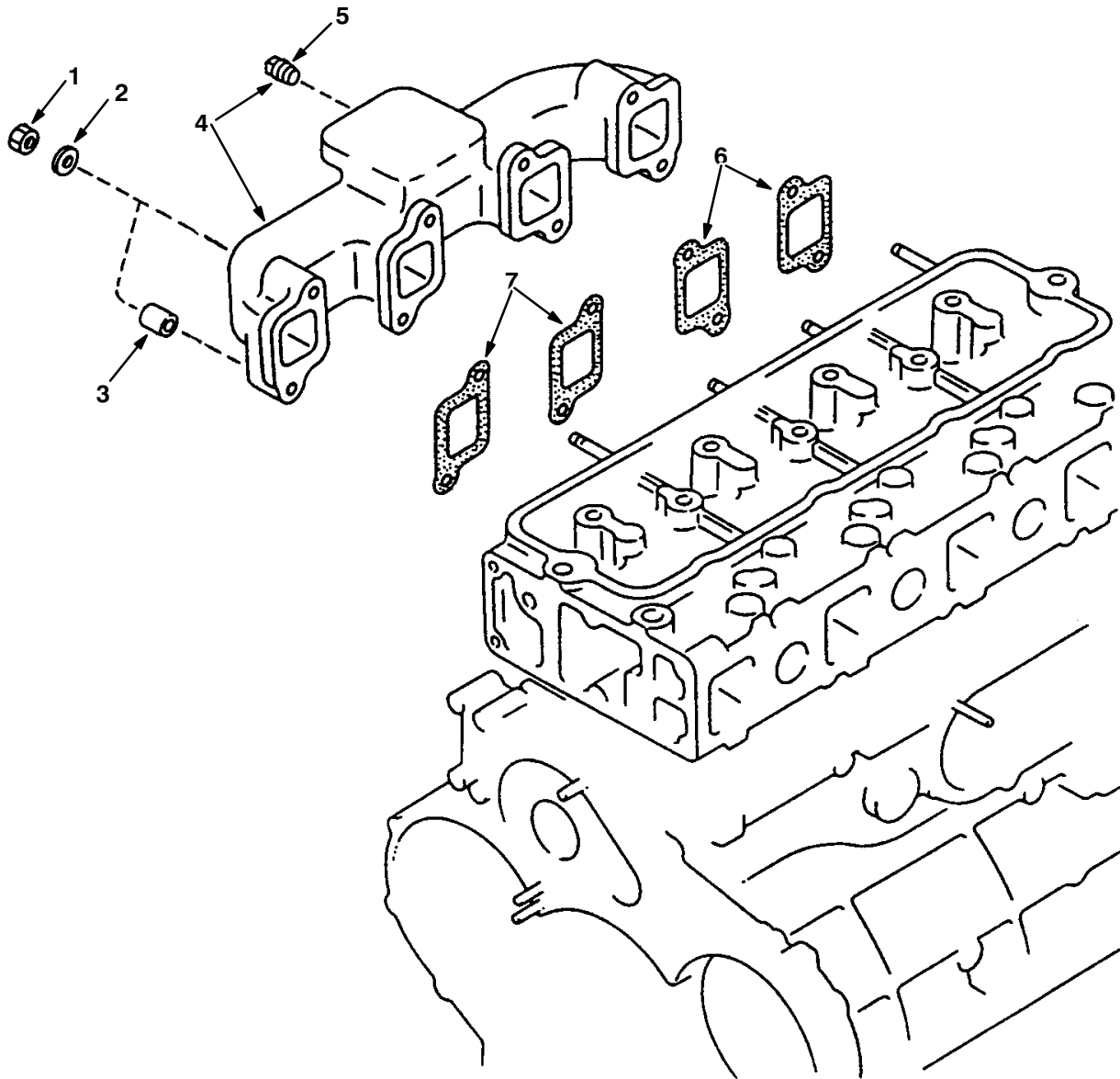

07702/07703

Ref.	Tennant Part No.	Perkins Part Number	Description	Qty.
1	74569	0305-13-461	Nut	8
2	74594	0710-11-513	Washer, Plain	8
3	74565	0191-18-363	Sleeve	1
∇ 4	74613	479313450A	Manifold, Exhaust	1
5	74661	99502-1000	Plug	1
6	74840	SL01-13-462A	Gasket, Exhaust Manifold	2
7	74839	SL01-13-461A	Gasket, Exhaust Manifold	2

Fig. 8 – Fuel Supply Group

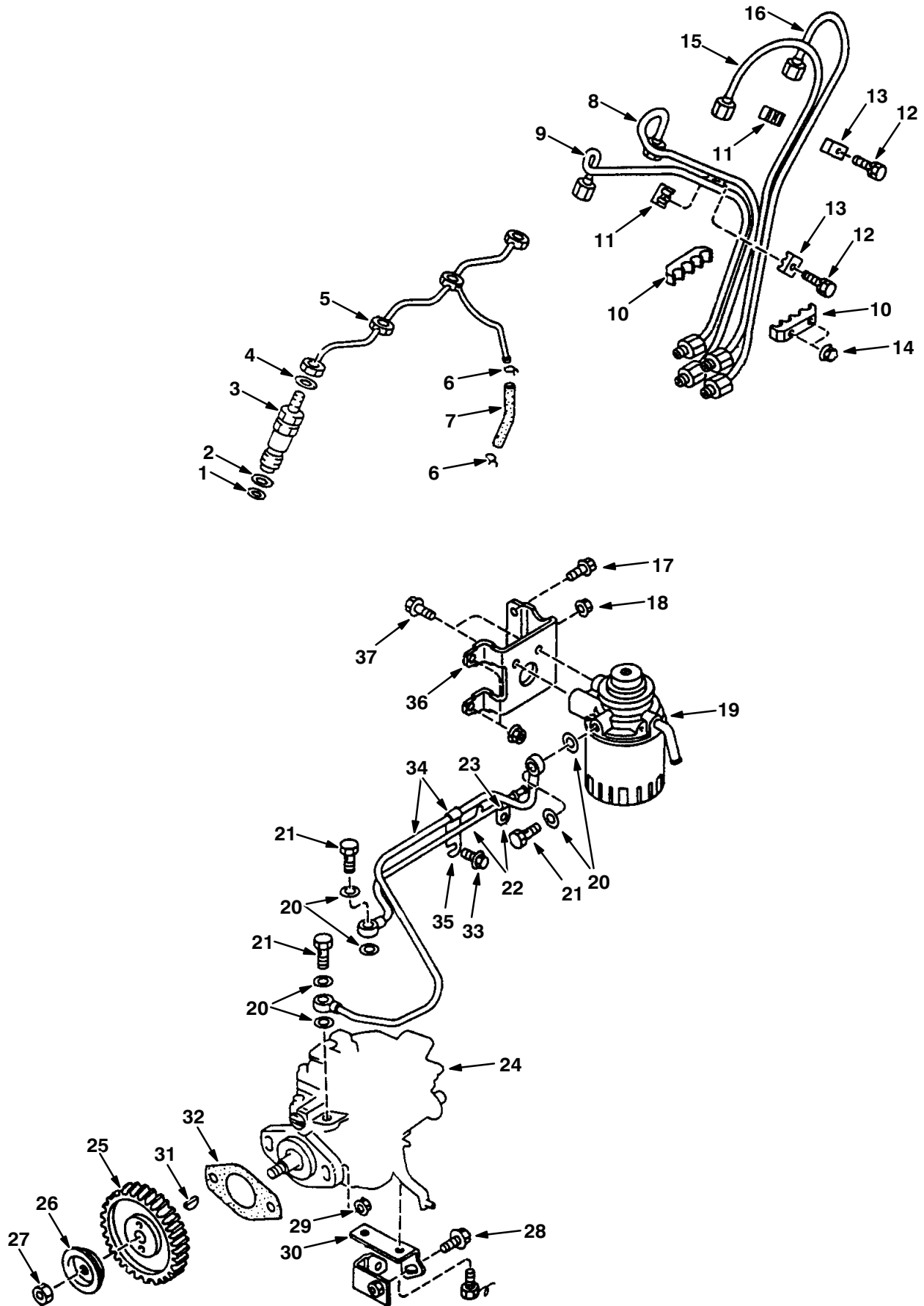

Fig. 8 – Fuel Supply Group

Ref.	Tennant Part No.	Perkins Part Number	Description	Qty.
1	74599	1304-13-654	Gasket	4
2	74590	0636-13-651	Washer, Nozzle	4
3	74740	S501-13-640A	Holder, Nozzle	4
4	74605	1456-13-671	Gasket, Leak Pipe	4
5	74811	SE08-13-670	Pipe, Fuel Leak	1
6	74654	99283-0900	Clamp	1
7	74851	SLA1-13-431	Hose, Fuel Return	1
8	74790	SE01-13-720	Pipe, Fuel Injection	1
9	74789	SE01-13-710	Pipe, Fuel Injection No.1	1
10	74728	PN11-13-G45	Clip, Pipe	2
11	74842	SL01-13-780	Clip, Injection Pipe	2
12	74641	90797-2525	Bolt	2
13	74841	SL01-13-770	Clip, Pipe	2
14	74720	99940-0500	Nut	2
15	74791	SE01-13-730	Pipe, Fuel Injection No.3	1
16	74792	SE01-13-740	Pipe, Fuel Injection	1
17	74698	99796-1016	Bolt	1
18	74722	99940-1000	Nut	1
19	74827	SEA1-13-480	Filter, Fuel	1
20	74669	99564-1200	Washer	6
21	74660	99381-10800	Fitting, Banjo	3
∇ 22	74597	0750-13-984	Pipe, Fuel Pump Feed	1
23	74812	SE08-13-680	Clip	1
∇ 24	74754	S5SN-13-800A	Pump, Injection	1
25	74828	SEA1-13-J12B	Gear, Injection Pump	1
26	74797	SE01-13-822	Washer	1
27	74794	SE01-13-801	Nut	1
28	74640	90796-0816	Bolt	1
29	74721	99940-0801	Nut	2
30	74796	SE01-13-810	Stay, Injection Pump	1
31	74652	99239-0316	Key, Woodruff	1
32	74795	SE01-13-805	Gasket, Injection Pump	1
33	74678	99769-0620	Bolt	1
∇ 34	74799	SE01-13-880A	Pipe, Fuel	1
35	74595	0727-13-985	Clip	1
36	74798	SE01-13-855A	Bracket, Fuel Filter	1
37	74699	99796-1020	Bolt	2

△ 388505 S5A113VF4 Solenoid, Fuel Lockoff

1

Fig. 9 – Fuel Filter Group

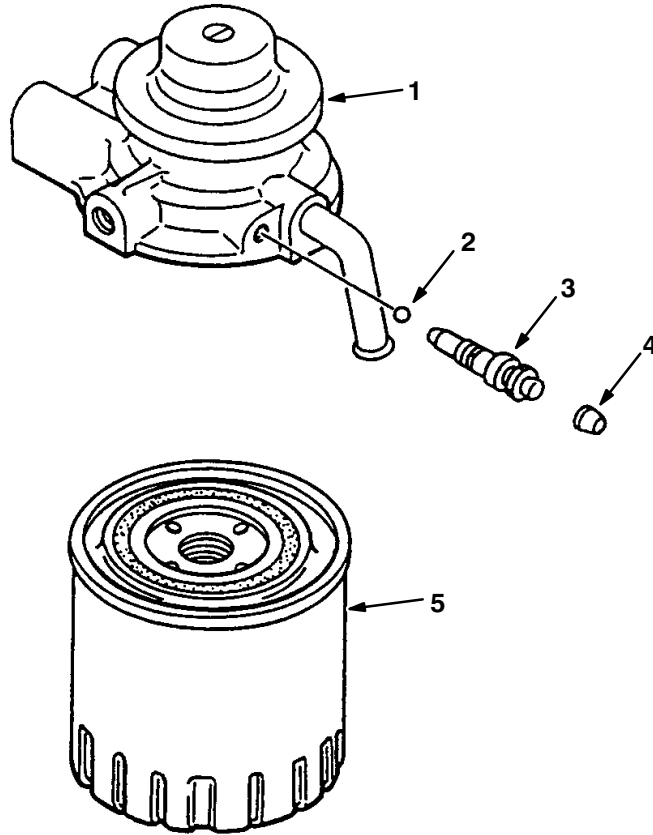

07704/07705

Ref.	Tennant Part No.	Perkins Part Number	Description	Qty.
1	74829	SEA1-13-ZAO	Cover	1
2	74677	99611-1500	Ball, Check	1
3	74607	259-33-691	Screw, Bleeder	1
4	74568	0259-33-693	Cap, Bleeder Screw	1
5	74858	TF01-13-ZA5	Filter, Fuel	1

Fig. 10 – Water Pump Group

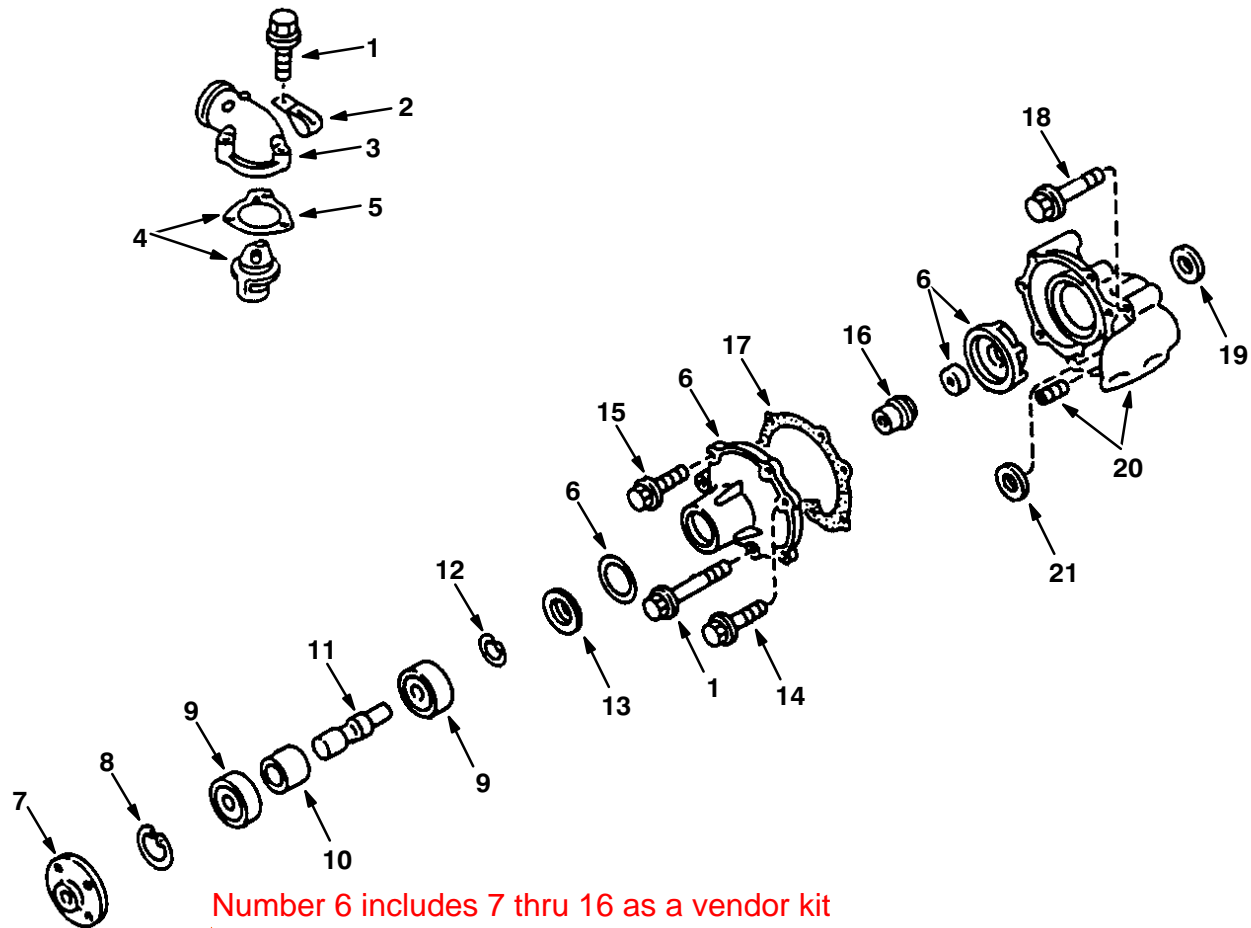

07710/07711

Ref.	Tennant Part No.	Perkins Part Number	Description	Qty.
1	74705	99796-830	Bolt	4
2	74653	99276-1808	Clamp	1
3	74756	SAE01-15-172	Cover, Thermostat	1
▽ 4	74813	SE08-99-152	Thermostat	1
5	74626	8599-15-173	Gasket, Thermostat	1
▽ 6	75729	8AW3-15-100B	Housing Assembly, Water Pump	1
7	74806	SE01-15-117	Boss, Water Pump Pulley	1
8	74673	99574-4700	Ring, Retaining	1
9	74676	99606-92040	Bearing	2
10	74596	0727-15-115	Spacer, Bearing	1
11	74830	SEA1-15-112	Shaft, Water Pump	1
12	74672	99573-2000	Ring, Retaining	1
13	75741	0727-15-119	Plate, Dust Seal	1
14	74689	99796-0825	Bolt	2
15	74697	99796-0880	Bolt	4
16	74726	FE1H-15-120	Seal, Water Pump	1
17	74836	SEM1-15-116	Gasket, Water Pump	1
18	74694	99796-0855	Bolt	1
19	74803	SE01-15-081	Gasket	1
20	74805	SE01-15-090	Body, Water Pump	1
21	74804	SE01-15-082	Gasket	1

Fig. 11 – Oil Pump and Filter Group

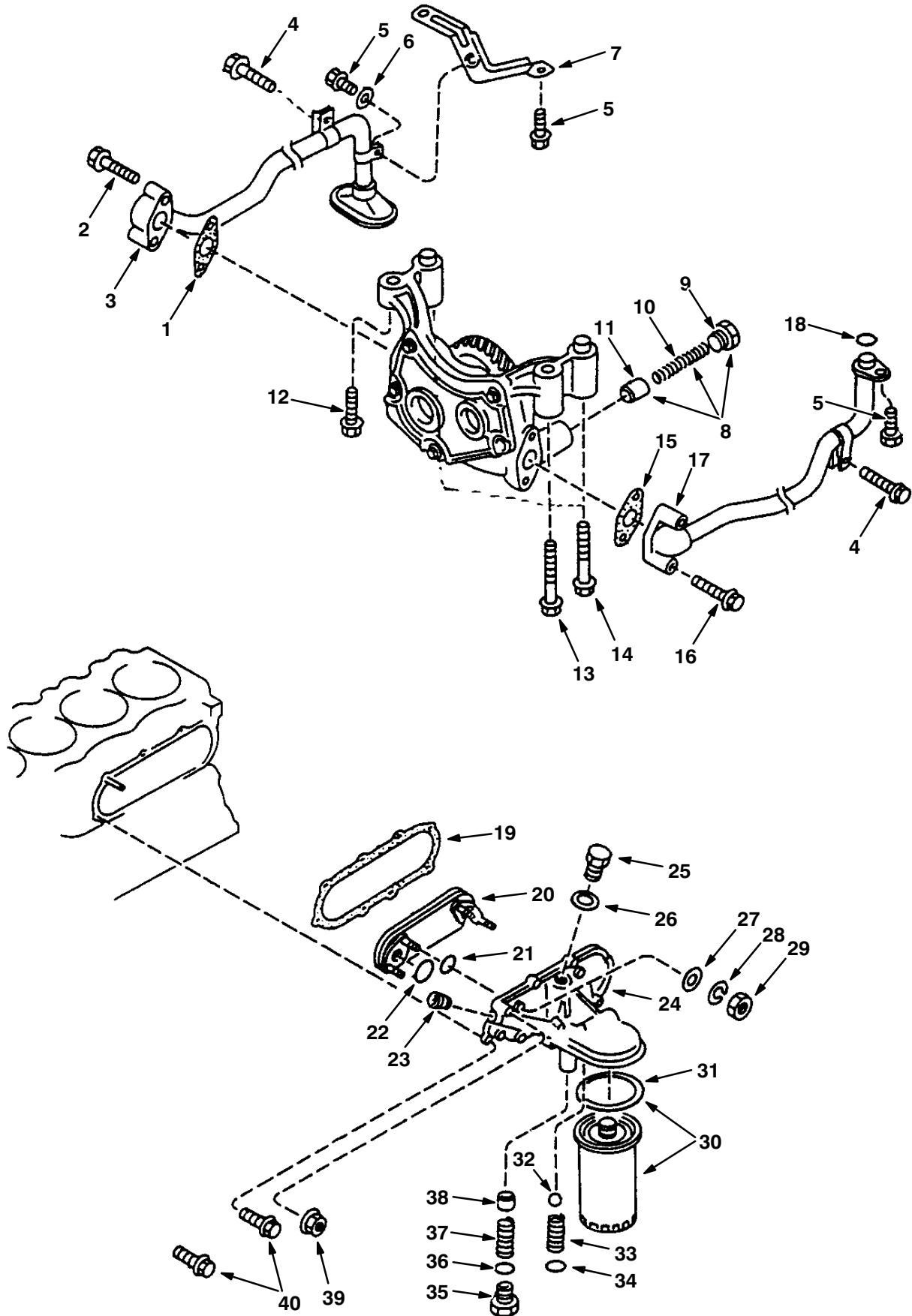

Fig. 11 – Oil Pump and Filter Group

Ref.	Tennant Part No.	Perkins Part Number	Description	Qty.
1	74845	SL11-14-248	Gasket, Suction Pipe	1
2	74685	99796-0630	Bolt	2
3	74852	SLA114240L	Strainer, Oil	1
4	74684	99796-0625	Bolt	5
5	74688	99796-0820	Bolt	4
6	74723	99951-0822	Washer	1
7	74755	S5SN-14-25X	Bracket, Oil Strainer	1
∇ 8	74849	SL70-14-100A	Pump, Oil	1
9	74800	SE01-14-117A	Plug	1
10	74801	SE01-14-152B	Spring, Oil Pressure	1
11	74591	0636-14-151	Plunger, Control	1
12	74701	99796-1035	Bolt	1
13	74702	99796-1050	Bolt	1
14	74703	99796-1060	Bolt	2
15	74844	SL11-14-214	Gasket, Oil Pipe	1
16	74685	99796-0630	Bolt	2
17	74850	SL70-14-210	Pipe, Oil	1
18	74667	99541-01605	O-Ring	1
19	74835	SEM1-14-342	Gasket, Oil Filter	1
20	74860	SE01-15-600	Cooler, Oil	1
21	74861	SE01-23-807	O-Ring	4
22	74862	SE01-23-808A	O-Ring	2
23	74663	99503-3000	Plug	1
24	74802	SE01-14-300D	Head, Oil Filter	1
25	74664	99510-2400	Plug	1
26	74671	99564-2400	O-Ring	1
27	75710	SE01-23-806	Washer	4
28	75709	SE01-23-805	Washer, Spring	4
29	74865	SE01-23-804	Nut	4
30	74863	TFYO-14-302	Filter, Oil	1
31	74864	1304-23-803	O-Ring	1
32	75725	SE01-23-819	Ball, Steel	1
33	75723	SE01-23-822A	Spring	1
34	75727	SE01-23-823	O-Ring	1
35	75714	SE01-23-811	Plug	1
36	75715	0727-23-812	O-Ring	1
37	75724	SE01-23-813	Spring, Valve	1
38	74591	0636-14-151	Plunger, Control	2
39	74686	99796-0801	Nut	2
40	74689	99796-0825	Bolt	8

Fig. 12 – Starter Group

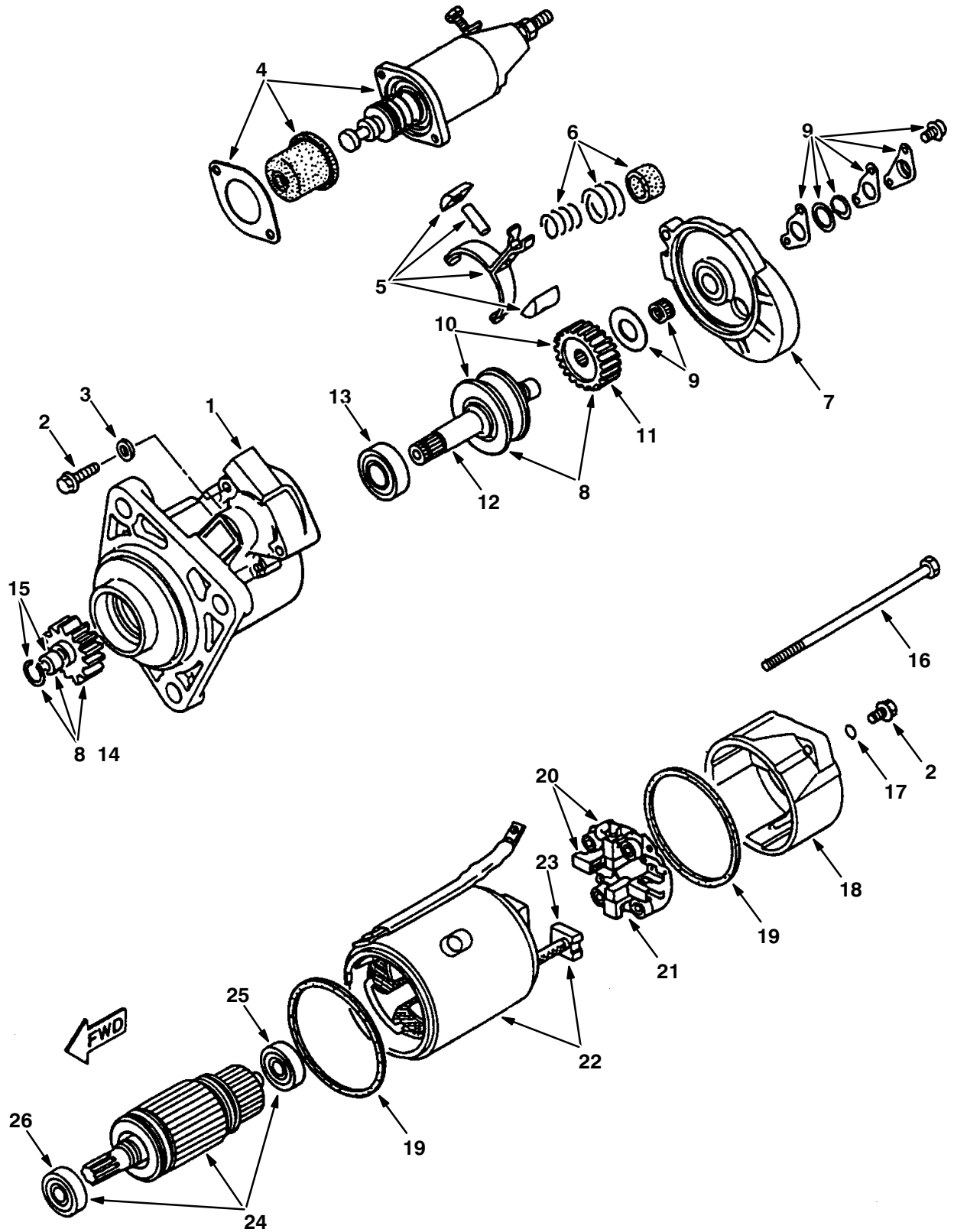
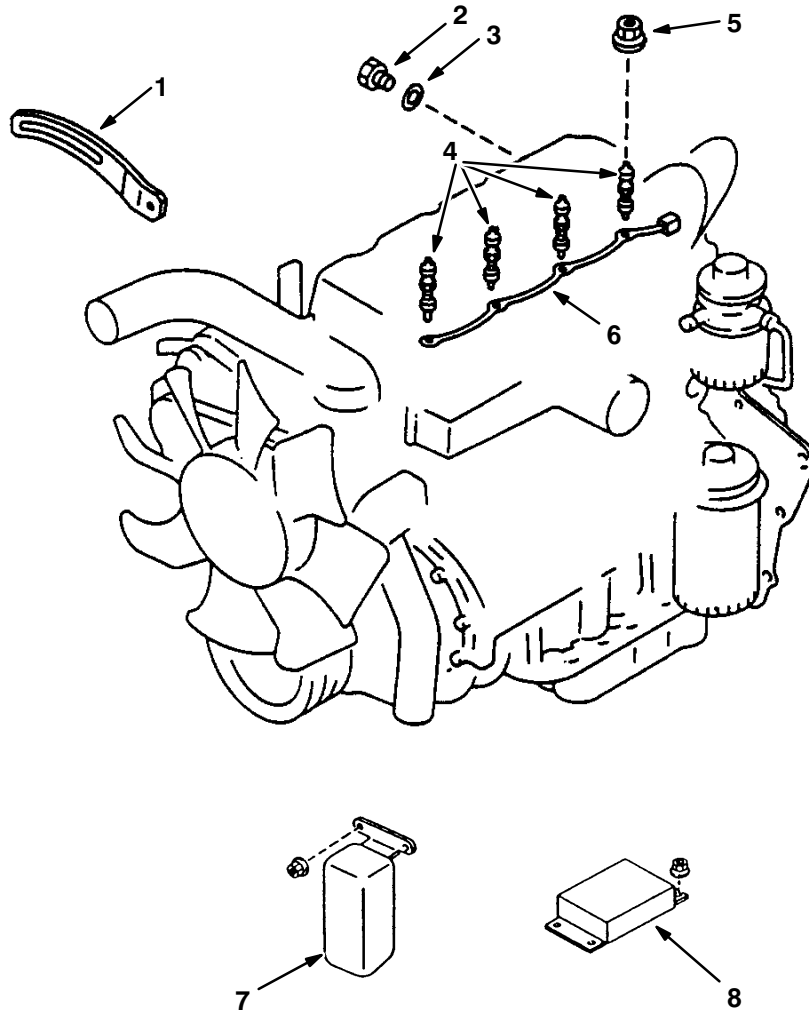

Fig. 12 – Starter Group

	Ref.	Tennant Part No.	Perkins Part Number	Description	Qty.
∇	1	74615	4840-18-400A	Starter	1
	2	74619	4840-24-728	Screw Set	1
	3	74639	8599-24-761	Gasket	2
	4	74609	4782-24-736	Switch	1
	5	74606	1456-24-731	Lever	1
	6	74610	4782-24-754	Spring Set	1
	7	74628	8599-24-721	Bracket, Center	1
	8	74616	4840-18-X20	Shaft, Clutch	1
	9	74633	8599-24-741	Cover Set	1
∇	10	74635	8599-24-744	Gear Set	1
	11	74636	8599-24-746	Gear	1
	12	74632	8599-24-740	Shaft	1
	13	74634	8599-24-743	Sleeve	1
∇	14	74617	4840-24-709	Pinion	1
	15	74627	8599-24-712	Stopper Set	1
	16	74631	8599-24-731	Bolt Set	1
	17	74600	1372-24-760	Ring, Rubber	2
	18	74618	4840-24-720	Bracket, Rear	1
	19	74630	8599-24-727	Gasket	2
∇	20	74637	8599-24-750	Holder, Brush	1
	21	74638	8599-24-752	Spring, Brush	4
∇	22	74620	4840-24-730	Yoke	1
	23	74745	S515-18-X66	Brush, Yoke	2
∇	24	74749	S5A1-18-X60	Armature	1
	25	74629	8599-24-722	Sleeve, Bearing-Rear	1
	26	74634	8599-24-743	Sleeve	1

Fig. 13 – Glow Plug Group



07712/07713

Ref.	Tennant Part No.	Perkins Part Number	Description	Qty.
1	74807	SE01-18-362	Strap, Alternator	1
2	74665	99511-1000	Plug	1
3	74668	99562-1000	Seal	1
4	74741	S501-18-140A	Plug, Glow	4
5	74729	R229-18-602	Nut, Flange	4
6	74731	RF11-18-154	Cord, Glow Plug	1
7	75804	R205-18-670	Relay, Glow Plug	1
8	75794	R201-18-701D	Control Unit	1

Fig. 14 – Temperature Gauge Group

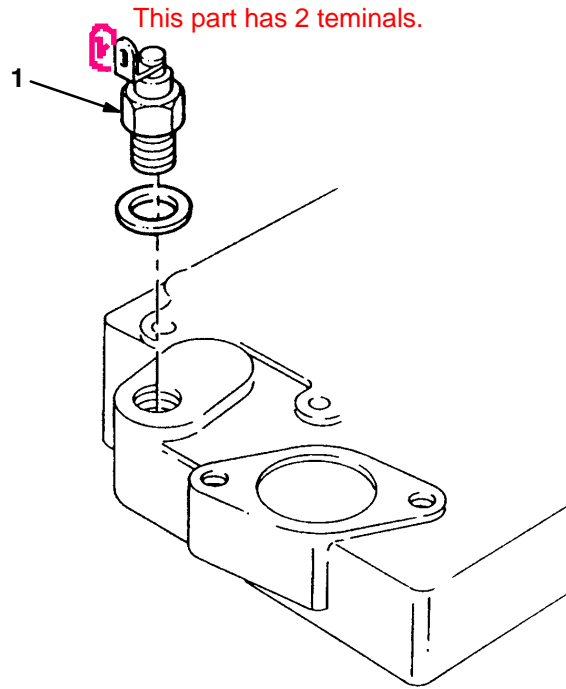

08780/08779

Ref.	Tennant Part No.	Perkins Part Number	Description	Qty.
1	75805	PN11-18-840	Sensor, Temperature	1

SECTION 6

CONTENTS

	PAGE
PART NUMBER TO PAGE NUMBER CROSS REFERENCE LIST	6-2
PART DESCRIPTION TO PAGE NUMBER CROSS REFERENCE LIST	6-21

CROSS REFERENCE

PART NUMBER TO PAGE NUMBER CROSS REFERENCE LIST

Part Number	Page Number	Part Number	Page Number
FE1H-15-120	5-17	SE01-12-114	5-11
HE03-10-404	5-7	SE01-12-116	5-11
MM308	3-74	SE01-12-118	5-11
MM308ES	3-74	SE01-12-130	5-11
MM308FR	3-74	SE01-12-133	5-11
MM337	3-74	SE01-12-160	5-11
PN11-13-G45	5-15	SE01-12-164	5-11
PN11-18-840	5-23	SE01-12-171A	5-11
R201-18-701D	5-22	SE01-12-172	5-11
R205-18-670	5-22	SE01-12-173	5-11
R229-18-602	5-22	SE01-12-181	5-11
RF01-10-454	5-5	SE01-12-310	5-11
RF11-18-154	5-22	SE01-13-710	5-15
S234-11-323	5-9	SE01-13-720	5-15
S234-11-327	5-9	SE01-13-730	5-15
S501-10-100J	5-3	SE01-13-740	5-15
S501-10-111B	5-3	SE01-13-786C	5-7
S501-10-271	5-3	SE01-13-801	5-15
S501-11-210	5-9	SE01-13-805	5-15
S501-11-213	5-9	SE01-13-810	5-15
S501-12-111	5-11	SE01-13-822	5-15
S501-13-640A	5-15	SE01-13-855A	5-15
S501-18-140A	5-22	SE01-13-880A	5-15
S501-23-051	5-5	SE01-14-117A	5-19
S501-23-200A	5-9	SE01-14-152B	5-19
S515-11-301	5-9	SE01-14-300D	5-19
S515-18-X66	5-21	SE01-15-081	5-17
S535-10-300B	5-5	SE01-15-082	5-17
S535-12-121	5-11	SE01-15-090	5-17
S5A1-02-200A	5-5	SE01-15-117	5-17
S5A1-18-X60	5-21	SE01-15-600	5-19
S5A1-23-110	5-9	SE01-18-362	5-22
S5A1-23-111	5-9	SE01-23-099	5-7
S5A1-23-112	5-9	SE01-23-804	5-19
S5A1-23-113	5-9	SE01-23-805	5-19
S5SN-13-800A	5-15	SE01-23-806	5-19
S5SN-14-25X	5-19	SE01-23-807	5-19
SAE01-15-172	5-17	SE01-23-808A	5-19
SE01-10-136	5-3	SE01-23-811	5-19
SE01-10-137	5-3	SE01-23-813	5-19
SE01-10-138	5-3, 5-5	SE01-23-819	5-19
SE01-10-155A	5-11	SE01-23-822A	5-19
SE01-10-2208	5-3	SE01-23-823	5-19
SE01-10-235A	5-3	SE08-10-227	5-3
SE01-10-255	5-3	SE08-10-229	5-3
SE01-10-352	5-5	SE08-13-670	5-15
SE01-10-372	5-5	SE08-13-680	5-15
SE01-10-460B	5-5	SE08-99-152	5-17
SE01-10-561	5-3	SE11-10-603	5-7
SE01-10-562	5-3	SE11-10-653	5-7
SE01-10-710	5-7	SE70-10-150	5-3
SE01-10-715	5-7	SE70-10-155A	5-11
SE01-10-730	5-7	SE70-10-600A	5-7
SE01-11-215	5-9	SE70-12-421	5-11
SE01-11-376A	5-9	SE70-14-268	5-7
SE01-11-377A	5-9	SEA1-10-380C	5-7
SE01-11-402	5-9	SEA1-10-450	5-5
SE01-12-112	5-11	SEA1-11-32X	5-9

CROSS REFERENCE

Part Number	Page Number	Part Number	Page Number
SEA1-11-401A	5-9	04414	2-15, 2-17
SEA1-12-400B	5-11	04483	4-42
SEA1-12-411B	5-11	0453-10-250A	5-3
SEA1-13-480	5-15	04664	2-15
SEA1-13-J12B	5-15	04706	2-133
SEA1-13-ZAO	5-16	04733-4	2-35
SEA1-15-112	5-17	04761	2-113, 3-35
SEM1-10-602	5-7	04843	2-45, 2-47, 3-59, 3-61
SEM1-10-650	5-7	0488-10-321	5-5
SEM1-11-399	5-9	0527-23-105	5-9
SEM1-13-111	5-12	0527-23-106	5-9
SEM1-14-342	5-19	0527-23-107	5-9
SEM1-15-116	5-17	0527-23-108	5-9
SL01-11-513	5-9	05611	2-131
SL01-13-104	5-12	05880	2-67
SL01-13-461A	5-13	05881	2-67
SL01-13-462A	5-13	0613-16-111	5-7
SL01-13-770	5-15	06146	2-107
SL01-13-780	5-15	0636-10-303	5-5
SL02-11-511G	5-9	0636-10-701A	5-7
SL11-14-214	5-19	0636-10-711	5-7
SL11-14-248	5-19	0636-12-115	5-11
SL70-10-33X	5-5	0636-12-166	5-11
SL70-11-315	5-9	0636-12-168A	5-11
SL70-12-403	5-11	0636-12-401A	5-11
SL70-14-100A	5-19	0636-12-404	5-11
SL70-14-210	5-19	0636-12-412	5-11
SLA1-13-431	5-15	0636-12-422A	5-11
SLA114240L	5-19	0636-12-431A	5-11
SLA11425X	5-7	0636-13-651	5-15
SLM1-10-153	5-3	0636-14-151	5-19
SLM1-11-310	5-9	0636-23-115	5-9
SLM1-11-318	5-9	0636-23-116	5-9
TF01-10-281A	5-3	06474A	2-109, 2-111
TF01-12-114	5-11	06537	2-113
TF01-13-ZA5	5-16	0710-11-513	5-13
TFYO-14-302	5-19	0727-13-985	5-15
00500-15	4-20	0727-15-115	5-17
00954	4-23	0727-15-119	5-17
00960	4-24	0727-23-812	5-19
01-11-214	5-9	07449	2-95
0110-18-515	5-3	0750-13-984	5-15
01274	2-45, 2-47, 3-21	07562	3-65
01433-1	2-3	07873	2-69, 2-71
01570	3-59, 3-61	08085	3-25
0191-18-363	5-13	08179	2-117
01987	2-101, 2-103	0911-23-206	5-9
01999	3-39	09718	2-87
0221-10-308	5-5	10136	2-83
0221-10-327	5-5	10632-11	3-11, 3-13
02247	2-69	10632-2	3-3, 3-5
02506-6	3-66	10632-20	3-3, 3-5, 3-7, 3-9
02549	2-101, 2-103	10632-4	2-55, 3-73
0259-33-693	5-16	10632-5	2-135, 3-16, 3-41
02713	2-131	10632-9	3-15, 3-16
03026	2-63, 2-65, 3-65	10664	2-3, 2-81
0305-13-461	5-13	10665	2-81
0324-10-252	5-3	10829	2-133
0370-39-025A	5-3	10911	2-107
03922	2-127, 2-129	11211	2-41

CROSS REFERENCE

Part Number	Page Number	Part Number	Page Number
11531	2-73	21138	2-67
11676	3-59, 3-61	21150	3-45
11716	2-125	21168	2-11, 2-13
11747	2-45, 2-47, 3-73	21170	3-25
11847	2-57, 2-59	21215	2-113
11848	2-57, 2-59, 3-65	21216	3-51
11984	3-65	21221	2-47
12263	2-19	21224	2-113
12549	3-49	21230	3-65
12976	2-57, 2-59	21231	2-117, 3-33
1304-13-654	5-15	21238	2-113
1304-23-803	5-19	21239	2-113
1372-24-760	5-21	21246	2-17
13902	4-29, 4-31, 4-33, 4-35	21250	3-35
13904	4-31, 4-33, 4-35, 4-37	21251	3-35
13907	4-3, 4-7, 4-11, 4-15	21252	3-35
14131	2-69, 2-71	21253	3-35
14138A	2-19	21270	3-53, 4-47
14242	2-89	21271	3-55, 4-51
14432	2-63, 2-65	21272	4-47, 4-51
1456-10-237	5-3	21273	3-53
1456-11-202	5-9	21274	3-53
1456-12-414A	5-11	21275	3-53
1456-12-418	5-11	21276	3-53
1456-13-671	5-15	21277	3-53
1456-24-731	5-21	21278	3-53
14595-1	2-95, 3-25	21279	4-47, 4-51
14601	2-95, 3-25	21280	4-47, 4-51
14605	2-59, 2-95, 2-109, 3-25	21282	2-11, 2-13
15555-1	2-71	21301	3-73
15555-2	2-71	21303	2-53
15724	2-69	21304	2-35
16236	3-21	21307	3-43
16431	2-103	21308	3-43
16455	2-111	21309	3-43
16456	2-33, 2-35	21310	3-43
16497	2-63, 2-65	21311	3-45
16694	4-21, 4-22	21312	3-45
16695	4-20, 4-21, 4-22	21313	3-45
17808	2-89	21642	2-21
17809	2-89	21643	2-21
17980	2-107, 2-109, 2-111, 3-35	21671	3-69
19035	3-59, 3-61	21689	2-81
19117	2-131, 4-23	21695	2-81
19459	2-97, 2-105	21721	2-43
19544	2-97	21722	2-43
19577	2-75	21917	4-28, 4-29, 4-35
19618	2-101	22024	2-9
19653	2-69	22290	2-133
20634	3-73	22297	2-73
21035	2-113, 3-35	23146	3-59, 3-61
21041	3-61	23498	2-129, 3-19
21047	3-61	24576-1	3-15, 3-16
21054	3-61	24576	3-15, 3-16
21104	3-61	24899	2-119
21113	2-117	25312	3-67
21117	2-103	25610	2-71
21119	2-103	259-33-691	5-16
21131	2-21	26395-1	2-55, 2-69
21136	2-67	26395-2	3-59, 3-61

CROSS REFERENCE

Part Number	Page Number	Part Number	Page Number
26565	3-61	34690	2-7
27048	2-71	34820	2-135
27767	3-55	34864	2-55, 3-73
27768	3-65	35033	2-105
28296	2-57	35323	2-5
29233	3-7, 3-9, 3-15	35324	2-5
29260	2-19, 3-25	35325	2-5
30013	2-109, 2-111	35326	2-5
30251	2-119	35327	2-5
30252	2-119	35336	2-5
30253	2-119	35424	3-65
30255	2-119	35493	4-27
30480	3-25	35529	2-33, 2-35
30533	3-70	35688	2-41, 2-43
31182	2-19	35980	2-57, 2-59
31354	4-20, 4-21	36050	2-71
31380	4-21, 4-22	36158	3-59, 3-61
31385	4-21, 4-22	36173	2-109
31504	2-127, 2-129	36192	2-27
31525	3-57	36328	2-113, 3-35
31563	2-103	36438	3-15, 3-16
31597	3-38	36439	3-15, 3-16
31599	2-79, 2-81	36556	2-111
31605	2-107	36758	2-7
31613	2-3, 2-105	37460	4-3, 4-7, 4-11, 4-15
31755	2-75, 2-77	37462	4-3, 4-7, 4-11, 4-15
31775	2-93	37555	4-21, 4-22
31999	2-53	37723	4-19
32006	2-53	37766	4-19
32009	2-53	37943	4-19
32133	3-53	39005	3-65
32134	3-53	39210	2-33, 2-35, 2-41, 2-43, 2-105, 2-109
32147	3-53	39231	2-61
32151	4-45, 4-47, 4-49, 4-51	39338	3-31
32491	2-71	39527	4-20
32492	3-33	39923	2-55, 3-73
32822	3-19, 3-23	40131	2-49
33404	2-121	40282	2-49
33799	2-101, 2-103	40380	4-19
33817	2-105	40514	2-105
33875	2-57, 2-59	40585	2-71
34159	4-5, 4-9, 4-13, 4-17	40607	2-55, 3-73
34176	4-20	40678	3-73
34178	4-19	40716	2-15, 2-17
34179	4-19	41073	2-87
34180	4-19	41074	2-87
34181	4-19	41128	3-53, 3-55
34182	4-19	41130	2-127, 2-129
34183	4-19	41131	2-117
34184	4-19	41141	3-41
34185	4-19	41178	2-11, 2-13, 2-17
34306	2-3, 2-105	41186	3-33
34330	2-119	41341	2-123
34355	2-101, 2-103	41434	3-49
34359	2-87, 2-121	42124	3-59, 3-61
34360	2-101, 2-103	42207	2-113
34365	2-57, 2-59	42215	2-105, 2-109, 2-111
34379	2-101, 2-103	42226	2-131
34390	2-105	42260	2-27, 2-105
34392	2-41, 2-43		

CROSS REFERENCE

Part Number	Page Number	Part Number	Page Number
43242	3-21	49263	2-69, 2-113, 2-133, 3-35
43454	2-55, 3-73	49266	2-55, 3-3, 3-5, 3-7, 3-9, 3-11, 3-13, 3-73
43500	2-3, 2-7, 2-9	49282	2-17
43555	2-53, 2-63, 2-65, 3-19, 3-23, 3-25, 3-51, 3-65	49933	2-109, 2-111
43611	2-57, 2-59	49934	2-69
43844	2-71, 3-65	50270	2-123
44078	2-133	50955	2-69
44681-1	3-5, 3-9, 3-13	51021N	2-5
44681-2	3-5, 3-9, 3-13	51109	2-93
44681	3-5, 3-9, 3-13	51176	2-15, 2-17
44777	2-15, 2-17	51193	2-89
44853	3-21	51305	2-75, 2-77
44868	2-107, 2-109, 3-35	51322	2-27
44869	2-107, 2-111, 2-119, 2-131	51338	2-89
44906	2-113, 3-35	51340	2-87
44961	3-73	51341	2-87
45272	3-3, 3-5, 3-7, 3-9, 3-11, 3-13	51373	2-89
45476	2-69	51448	2-119
45482	2-107, 3-35	51449	2-119
45622	4-19	51483	2-93
45623	4-19	51531	3-59, 3-61
45628	4-20, 4-21, 4-22	51534	2-121
45779	3-3, 3-5, 3-7, 3-9, 3-11, 3-13	51542	2-5
45780	2-7, 2-9	51545	2-93
45786	2-91	51560-5	2-63, 2-65, 3-65
46236	2-93, 3-73	51562	2-93
46481	2-79, 2-81, 2-97	51564	2-119
46482	2-33, 3-33	51693	2-123, 2-125
47504	2-111, 2-117	51787	2-27, 2-45, 2-47
47508	2-97, 2-113, 3-35	51813	2-117, 3-33
47512	2-33, 2-35, 2-79, 2-81, 2-109	51963	2-5
47585	2-133	52296	3-31
47637	3-35	52402	2-79, 2-81, 2-111, 2-131
47638	2-33, 2-35, 2-109, 2-111	52424	2-69
47752	2-109	52580-2	2-63, 2-65
47753	3-35	52911	2-97
4782-10-400A	5-7	53434	2-119, 4-20
4782-24-736	5-21	53461-2	2-19, 2-21, 2-23, 2-25
4782-24-754	5-21	53601	2-87, 4-42
4783-13-100	5-12	54009	3-59, 3-61
4793-10-RROA	5-7	54012	3-59, 3-61
479313450A	5-13	54096	2-121
4810-11-500B	5-9	54222	2-95
48267	2-69, 2-71	54274	2-131
4840-18-400A	5-21	54275A	2-131
4840-18-X20	5-21	54333	2-59
4840-24-709	5-21	54400	2-115, 3-31
4840-24-720	5-21	54615	2-15, 2-17, 3-65
4840-24-728	5-21	54663	2-115, 3-31
4840-24-730	5-21	54848	2-115, 3-31
48813	4-27	54878	2-119
4882-11-504	5-9	55042	4-45, 4-47, 4-49, 4-51
48842	3-74	55248	3-3, 3-5, 3-7, 3-9, 3-11, 3-13
4890-10-902A	5-7	55455	2-69
4891-12-132A	5-11	55586	2-119
4892-11-502	5-9	55685	2-109, 2-111
		55686	2-33, 2-35
		55700	2-103

CROSS REFERENCE

Part Number	Page Number	Part Number	Page Number
55779	2-119	58858	2-97, 2-105
55838	2-57	58898	2-11, 2-13
55844	2-71	59015	2-71
55850	2-71	59192	2-23, 2-25, 3-65
56186	2-137, 3-3, 3-5, 3-7, 3-9, 3-11, 3-13, 3-73	59195	2-45
56346	2-135	59305	4-18
56398	2-133	59577	2-107
56624	2-115, 2-117, 3-31, 3-33	59633	2-53
56690	2-107, 2-109, 2-117, 2-133, 3-33, 3-35	59661	2-19, 2-21, 2-27
56692	2-97, 2-131	59668	2-95
56708	2-69	59672	2-95
56811	2-69	59703	2-19, 2-21
56820	2-87, 2-117, 3-33	59734	2-77
56821	2-131	59767	2-149
57048	2-57, 2-59	59919	3-19
57152	4-25	59921	3-73
57167	2-137	59945	2-69, 2-71
57173	2-101, 2-103	59954	3-73
57288	2-69	59962	2-115, 3-31
57311	2-93	59965	2-31, 3-15, 3-16
57411	2-109, 2-111	59970	2-135
57483	2-101	59971	2-135
57485	2-101, 2-103	59974	2-135
57543	2-127	59976	2-135
57564	2-15	59977	2-135
57751	2-137	59978	2-135
57772	2-117	59979	2-135
57773	2-57, 2-59	60090	2-57, 2-59
57792	2-79	60292	2-83
57803	2-137	60293	2-83, 2-85
57807	2-117, 2-135, 3-33	60559	2-61
57820	2-15, 2-17, 2-25	60714	3-57
57936	2-29, 2-31, 2-33, 2-35	60732	2-119
57941	2-7, 2-9	60933	3-65
57944	2-103	60934	3-65
57963	2-101, 2-103, 3-39	61288	2-105
57988	2-109, 2-111	61363	2-61
57993	2-107	61424	3-41
57994	2-105	61490	4-20, 4-21, 4-22
58012	4-18	61838	3-74
58013	4-18	61882	4-3, 4-7, 4-11, 4-15
58114	2-129	61886	4-5, 4-9, 4-13, 4-17
58228	2-75, 2-77, 2-127, 2-129	61920	3-15, 3-16
58242	4-18	61927	4-27
58270	4-20	61969	2-135
58278	4-20	62172	2-109, 2-111
58279	2-115, 3-31, 3-33	62173	2-109, 2-111
58293	2-29, 2-31	62377	2-73
58357	2-53	62389	2-97
58359	2-33, 2-35	62548	2-97, 4-3, 4-5, 4-11, 4-13
58489	2-11, 2-23, 2-25	62561	2-97, 4-18
58494	2-19, 2-21, 2-115, 3-31	62564	2-113, 3-35, 4-21
58518	3-3, 3-7, 3-11	62565	2-133, 4-25
58519	3-3, 3-7, 3-11	62567	2-109, 4-36
58520	3-3, 3-7, 3-11	62595-18	3-11, 3-13, 3-15, 3-16
58524	2-45, 2-47	62595-2	2-15, 2-17
58596	4-25, 4-26	62595-3	2-17
58844	2-13, 3-65	62954	2-3, 2-7, 2-9
		62955	2-3, 2-7, 2-9
		62956	2-3, 2-7, 2-9

CROSS REFERENCE

Part Number	Page Number	Part Number	Page Number
62957	2-3, 2-7, 2-9	63665	2-37, 2-39
62960	2-7	63667	2-37, 2-39
62969	2-57	63668	2-37, 2-39
62975	2-33, 2-35, 4-43	63669	2-37, 2-39
62985	2-29	63671	2-49, 2-51
62988	2-29	63673	2-37
62990	2-29	63676	2-49
62991	2-29	63677	2-49
62992	2-29, 2-31	63693	2-57, 2-59
62993	2-29, 2-31, 2-33	63695	2-57, 2-59
62996	2-29, 2-31	63710	2-15
63191	2-75	63751	2-15, 2-17
63205	2-69	63776	2-29, 2-31
63218	2-91	63818	2-75, 2-77
63226	3-68	63850	2-91
63228	3-68, 3-69	63926	2-29, 2-31
63233	2-53	63968	2-105
63234	2-53	64034	2-121
63275	2-95	64058	2-91
63276	2-95	64059	2-91
63279	2-79, 2-81	64097	2-57, 2-59
63280	2-79, 2-81	64098	2-57, 2-59
63281	2-89	64132	2-121
63286	2-89	64156	2-33, 2-35
63290	2-89	64165	2-109
63292	2-95	64166	2-109
63294	2-15, 2-17	64175	2-109
63295	2-93	64176	2-109
63297	2-53	64228	2-107
63311	2-53	64232	2-41
63378	2-41, 2-47	64233	2-121
63407	3-71	64278	2-19, 2-21
63416	2-41, 3-35	64279	2-19, 2-21
63417	2-148	64299	2-75, 2-127, 2-129
63426	2-87, 4-19	64312	2-19, 2-21
63436	2-119	64320	3-19, 3-23
63449	2-119	64392	2-53
63450	2-119	64394	2-53
63471	2-87	64406	2-75
63491	2-87	64410	2-53
63496	2-87	64419	2-27
63527	2-107, 4-31	64434	2-109, 2-111
63535	2-57, 2-59	64436	2-57, 2-59
63540	2-87	64440	2-19
63541	2-119	64500	2-53
63542	2-79, 2-81, 4-24	64501	2-53
63543	2-87	64543	2-23, 2-25
63544	2-7, 2-9	64545	2-23, 2-25
63551	2-95	64550	2-93
63583	2-33, 2-35	64554	2-93
63584	2-33, 2-35	64556	2-93
63585	2-33, 2-35	64558	2-93
63589	2-41	64559	2-53
63591	2-87	64567	2-53
63599	2-79	64580	2-53
63632	2-49	64586	2-133
63647	2-37, 2-39	64595	2-19, 2-21
63648	2-37	64618	2-53, 2-75, 2-77, 2-127, 2-129
63662	2-49		
63663	2-7, 2-9		

CROSS REFERENCE

Part Number	Page Number	Part Number	Page Number
64621	2-53, 2-75, 2-77, 2-127, 2-129	65223	2-33
64631	2-133	65224	2-101, 2-103
64632	2-95	65225	2-69
64635	2-93	65226	4-18
64648	2-127	65227	4-19
64651	2-133	65232	4-21, 4-22
64655	2-133	65233	4-25
64692	2-61	65234	4-25
64726	2-19, 2-21	65235	4-25, 4-26
64744	2-19, 2-21	65236	4-25
64788	2-3, 2-11, 2-13	65237	4-25
64801	2-11	65238	4-25
64802	2-13	65239	2-131
64811	2-119	65240	4-31, 4-33, 4-35
64812	2-123	65242	2-133, 4-26
64873	2-53	65245	2-135
64874	2-53	65246	2-95
64884	2-15, 2-17	65248	2-121
64886	2-87	65249	2-121
64887	2-87	65252	2-27
64893	2-41, 2-43	65258	3-17
64905	2-109, 2-111	65278	2-45, 2-47
64919	2-3, 2-7, 2-9	65281	2-45, 2-47
64920	2-3, 2-7, 2-9	65285	2-45
64923	2-11, 2-13	65287	2-41
64942	2-61	65290	2-45
64950	2-93	65294	2-115
65003	2-19	65302	2-41
65099	2-57, 2-59	65391	2-131, 3-35, 4-27
65129	2-93	65561	2-117, 3-33
65145-1	2-97	65869-5	2-3
65158	2-67	67310	2-87, 2-97
65160	2-113, 3-35	67683	3-35
65168	2-113	67767	2-33, 2-35, 2-69, 2-71, 2-87
65170	2-113	68445	3-49
65173	2-113, 3-35	68869	2-85
65174	2-113, 2-117, 3-33, 3-35	68872	2-83
65180	2-113, 3-35	68873	2-83
65188	2-101, 2-103	69495	2-57, 2-59
65191	2-101, 2-103	69582	2-115, 3-31
65194	2-101, 2-103, 3-39	69904	2-7, 2-9
65195	2-101, 2-103	69906	2-45, 2-47
65196	2-101, 2-103	69918	3-19, 3-23
65197	2-101, 2-103	69937	3-19, 3-23
65199	2-101, 2-103	69981	3-19, 3-23
65201	2-101, 2-103	70006	2-105
65202	2-101, 2-103	70072	2-105
65204	2-101, 2-103	70388	2-37, 2-39
65205	2-101, 2-103	70389	2-57, 2-59
65208	2-101	70398	2-137
65209	2-101	70400	2-148
65210	2-101	70401	2-69, 2-71
65211	2-101	70402	2-137
65212	2-101, 2-103	70407	2-23, 2-25
65213	2-101, 2-103	70408	2-19, 2-21
65215	2-105	70411	2-137
65220	2-79	70431	2-113, 3-35
65221	2-79, 2-81	70444	2-115, 3-31
65222	2-79, 2-81, 3-57	70450	2-15, 2-17

CROSS REFERENCE

Part Number	Page Number	Part Number	Page Number
70451	2-7	70703	2-79, 2-81
70453	2-3, 2-11, 2-13	70705	2-149
70454	3-17	70709	2-133
70459	2-33	70710	2-75
70461	2-79	70711	2-75
70472	2-45	70712	2-75, 2-77
70477	2-69, 2-71	70715	2-115
70478	2-15, 2-17	70717	2-133
70489	3-53	70720	2-115
70497	2-67	70725	2-95
70498	2-7	70730	2-45, 2-47
70504	2-93	70742	2-45, 2-47
70505	2-93	70744	2-75
70506	2-93	70747	2-95
70507	2-73	70749	2-95
70511	2-93	70752	2-57, 2-59
70513	3-53	70753	2-73
70514	2-33, 2-35	70756	2-15, 2-17, 3-21
70517	2-7	70761	2-45, 2-47, 3-49
70521	2-113	70762	2-45, 2-47
70523	2-33	70775	2-131
70524	2-113, 3-35	70780	2-107
70525	2-113, 3-35	70783	2-95
70526	2-113, 3-35	70784	2-127
70528	2-49	70785	3-43
70532	2-49, 2-113, 3-35	70788	3-43
70536	2-149	70790	2-131
70538	2-5	70793	3-27, 3-28, 3-29
70539	2-83	70797	3-31
70540	2-83	70802	3-27, 3-28, 3-29
70541	2-83	70808	2-13
70550	2-93	70809	2-11
70552	2-27	70810	2-131
70564	2-15, 2-17	70815	3-27, 3-28, 3-29
70583	2-121	70825	2-127, 2-129
70595	2-45	70827	2-109, 2-111
70596	2-19, 2-21	70833	2-63, 2-65
70597	2-11	70835	2-63, 2-65
70598	2-13	70836	2-63, 2-65
70620	2-15	70838	2-63
70622	2-133	70843	2-7, 2-9
70623	2-133	70844	2-7, 2-9
70626	2-113, 3-35	70847	2-109, 2-111
70627	2-113, 3-35	70851	2-45, 3-73
70628	2-23, 2-25	70852	2-45
70635	2-73	70853	2-45
70637	2-135	70854	2-41
70649	2-5	70855	2-41
70650	2-53	70857	2-127
70651	2-53	70858	2-79
70652	2-127	70859	2-79
70659	3-59, 3-61	70861	2-115
70668	3-59, 3-61	70870	3-21
70669	3-17	70871	3-21
70684	3-27	70876	3-65
70686	3-26	70877	2-127
70690	3-70	70878	3-21
70692	3-67	70879	3-21
70696	3-15	70885	3-27
70699	3-41	71025	3-19, 3-23

CROSS REFERENCE

Part Number	Page Number	Part Number	Page Number
71552	2-101, 2-103	73860	2-115
72109	2-135	73862	2-7, 2-9
72968	3-65	73863	2-7, 2-9
73140	2-77	73867	2-67
73645	2-7, 2-9	73868	2-73
73646	2-127, 2-129	73870	2-3, 2-11, 2-13
73648	2-11	73871	3-59, 3-61
73649	2-13	73877	3-59
73650	2-127, 2-129	73878	3-59
73653	3-19, 3-23	73880	3-59, 3-61
73654	2-3, 2-11, 2-13	73883	3-59
73655	3-21	73884	3-59
73656	3-21	73887	2-39
73660	3-21	73888	2-3, 2-11, 2-13
73661	3-21	73893	2-19
73663	3-21	73897	2-73
73664	3-21	73898	3-3, 3-5, 3-7, 3-9
73671	3-21	73899	3-3, 3-5, 3-7, 3-9
73674	3-21	73901	2-15, 2-17
73675	3-19	73903	2-15, 2-17
73677	3-19, 3-23	74000	3-3, 3-5, 3-7, 3-9, 3-11, 3-13
73678	2-37, 2-39	74005	2-123
73679	2-37, 2-39	74007	3-17
73685	2-127, 2-129	74009	2-127
73688	3-27	74015	2-45, 2-47
73689	3-19, 3-23	74020	2-63, 2-65
73691	2-15	74022	2-93
73692	3-19	74023	2-127
73700	3-19, 3-23	74025	2-123
73709	3-19	74031	2-115, 3-31
73714	2-115, 3-31	74038	2-7
73722	2-7	74040	2-19, 2-21
73724	2-7, 2-9	74042	2-79
73727	2-55	74043	2-73
73731	2-87	74045	2-37, 2-39
73733	2-87	74046	2-37, 2-39
73734	2-53	74051	2-95
73735	2-63	74052	2-95
73736	2-33	74059	2-113, 3-35
73737	2-115, 2-117, 3-31, 3-33	74060	2-113
73748	2-37	74062	2-11
73749	2-37, 2-39	74063	2-13
73751	3-7	74064	2-7, 2-9
73753	3-9	74066	2-7, 2-9
73755	3-3	74067	2-7, 2-9
73757	3-5	74068	2-115
73759	3-11	74069	2-39
73761	3-13	74070	2-49
73762	2-123	74074	3-59, 3-61
73771	2-37, 2-39	74081	2-15, 2-17
73772	2-37, 2-39	74083	3-59
73784	2-63, 2-65	74090	2-115, 2-117, 3-31, 3-33
73794	2-63	74091	3-55, 4-49
73798	2-57, 2-59	74094	4-21, 4-22
73799	2-57, 2-59	74098	4-31, 4-33, 4-35
73818	2-115, 3-31	74100	4-21, 4-22
73841	2-19	74101	4-21, 4-22
73843	2-19	74106	4-25
73856	2-115	74109	4-25, 4-26
73858	3-53		

CROSS REFERENCE

Part Number	Page Number	Part Number	Page Number
74110	4-25, 4-26	74279	4-5, 4-9, 4-13, 4-17
74111	4-25, 4-26	74280	4-3, 4-7, 4-11, 4-15
74112	4-25, 4-26	74281	4-3, 4-7, 4-11, 4-15
74113	4-25	74282	4-5, 4-9, 4-13, 4-17
74114	4-25	74283	4-7, 4-9, 4-15, 4-17
74115	4-25	74284	4-5, 4-13
74116	4-25	74285	4-11, 4-15, 4-39
74118	4-25	74286	4-3, 4-11
74126	4-36	74287	4-3, 4-11
74128	4-36	74288	4-3, 4-11
74129	4-36	74289	4-3, 4-11
74130	4-36	74391	2-117
74131	4-36	74563	5-9
74132	4-19	74564	5-3
74133	4-19	74565	5-13
74134	4-19	74566	5-5
74135	4-19	74567	5-5
74136	4-19	74568	5-16
74137	4-19	74569	5-13
74145	4-29, 4-31	74570	5-3
74146	4-31, 4-33, 4-35	74571	5-3
74163	2-97, 4-7, 4-9	74572	5-3
74164	3-71, 4-15, 4-17	74573	5-5
74174	4-26	74574	5-9
74182	4-26	74575	5-9
74184	4-3, 4-7, 4-11, 4-15	74576	5-9
74190	4-26	74577	5-9
74194	4-26	74578	5-7
74210	4-3, 4-7, 4-11, 4-15	74579	5-5
74218	4-26	74580	5-7
74223	4-3, 4-7, 4-11, 4-15	74581	5-7
74224	4-3, 4-11	74582	5-11
74233	4-23, 4-24	74583	5-11
74240	4-3, 4-7, 4-11, 4-15	74584	5-11
74250	4-21, 4-22	74585	5-11
74251	4-26	74586	5-11
74253	4-7, 4-15	74587	5-11
74254	4-7, 4-15	74588	5-11
74256	4-3, 4-7, 4-11, 4-15	74589	5-11
74257	4-3, 4-7, 4-11, 4-15	74590	5-15
74258	4-7, 4-15	74591	5-19
74259	4-5, 4-9, 4-13, 4-17	74592	5-9
74260	4-5, 4-9, 4-13, 4-17	74593	5-9
74261	4-5, 4-9, 4-13, 4-17	74594	5-13
74262	4-3, 4-7, 4-11, 4-15	74595	5-15
74263	4-7, 4-15	74596	5-17
74264	4-9, 4-17	74597	5-15
74265	4-3, 4-7, 4-11, 4-15	74598	5-9
74266	4-3, 4-7, 4-11, 4-15	74599	5-15
74267	4-3, 4-7, 4-11, 4-15	74600	5-21
74268	4-31, 4-33, 4-35	74601	5-3
74270	4-5, 4-9, 4-13, 4-17	74602	5-9
74271	4-5, 4-9, 4-13, 4-17	74603	5-11
74272	4-3, 4-7, 4-11, 4-15	74604	5-11
74273	4-3, 4-7, 4-41	74605	5-15
74274	4-5, 4-9, 4-13, 4-17	74606	5-21
74275	4-5, 4-9, 4-13, 4-17	74607	5-16
74276	4-3, 4-7, 4-11, 4-15	74608	5-7
74277	4-5, 4-9, 4-13, 4-17	74609	5-21
74278	4-5, 4-9, 4-13, 4-17	74610	5-21

CROSS REFERENCE

Part Number	Page Number	Part Number	Page Number
74611	5-12	74672	5-17
74612	5-7	74673	5-17
74613	5-13	74674	5-11
74614	5-9	74675	5-9
74615	5-21	74676	5-17
74616	5-21	74677	5-16
74617	5-21	74678	5-15
74618	5-21	74679	5-11
74619	5-21	74680	5-9
74620	5-21	74681	5-3
74621	5-9	74682	5-3
74622	5-7	74683	5-3
74623	5-11	74684	5-19
74624	5-9	74685	5-19
74625	5-7	74686	5-19
74626	5-17	74687	5-3, 5-11
74627	5-21	74688	5-7, 5-12, 5-19
74628	5-21	74689	5-7, 5-12, 5-17, 5-19
74629	5-21	74690	5-7, 5-9
74630	5-21	74691	5-3
74631	5-21	74692	5-3
74632	5-21	74693	5-7, 5-11
74633	5-21	74694	5-7, 5-17
74634	5-21	74695	5-7
74635	5-21	74696	5-7
74636	5-21	74697	5-17
74637	5-21	74698	5-15
74638	5-21	74699	5-3, 5-15
74639	5-21	74700	5-7
74640	5-15	74701	5-7, 5-19
74641	5-15	74702	5-19
74643	5-3	74703	5-19
74644	5-5	74704	5-3
74645	5-7	74705	5-7, 5-17
74646	5-9	74706	5-7
74647	5-5	74707	5-7
74648	5-7	74708	5-7
74649	5-7	74709	5-7
74650	5-5	74710	5-7
74651	5-9	74711	5-3
74652	5-15	74712	5-5
74653	5-17	74713	5-7
74654	5-15	74714	5-5
74655	5-5	74715	5-5
74656	5-11	74716	5-7
74657	5-3, 5-5	74717	5-3
74658	5-5	74718	5-3
74659	5-3	74719	5-11
74660	5-15	74720	5-15
74661	5-13	74721	5-7, 5-12, 5-15
74662	5-3, 5-5	74722	5-15
74663	5-19	74723	5-19
74664	5-19	74724	5-11
74665	5-22	74725	5-7
74666	5-7	74726	5-17
74667	5-19	74727	5-7
74668	5-22	74728	5-15
74669	5-7, 5-15	74729	5-22
74670	5-7	74730	5-5
74671	5-19	74731	5-22

CROSS REFERENCE

Part Number	Page Number	Part Number	Page Number
74732	5-9	74792	5-15
74733	5-9	74793	5-7
74734	5-3	74794	5-15
74735	5-3	74795	5-15
74736	5-3	74796	5-15
74737	5-9	74797	5-15
74738	5-9	74798	5-15
74739	5-11	74799	5-15
74740	5-15	74800	5-19
74741	5-22	74801	5-19
74742	5-5	74802	5-19
74743	5-9	74803	5-17
74744	5-9	74804	5-17
74745	5-21	74805	5-17
74746	5-5	74806	5-17
74747	5-11	74807	5-22
74748	5-5	74808	5-7
74749	5-21	74809	5-3
74750	5-9	74810	5-3
74751	5-9	74811	5-15
74752	5-9	74812	5-15
74753	5-9	74813	5-17
74754	5-15	74814	5-7
74755	5-19	74815	5-7
74756	5-17	74816	5-3
74757	5-3	74817	5-11
74758	5-3	74818	5-7
74759	5-3, 5-5	74819	5-11
74760	5-11	74820	5-7
74761	5-3	74821	5-7
74762	5-3	74822	5-5
74763	5-3	74823	5-9
74764	5-5	74824	5-9
74765	5-5	74825	5-11
74766	5-5	74826	5-11
74767	5-3	74827	5-15
74768	5-3	74828	5-15
74769	5-7	74829	5-16
74770	5-7	74830	5-17
74771	5-7	74831	5-7
74772	5-9	74832	5-7
74773	5-9	74833	5-9
74774	5-9	74834	5-12
74775	5-9	74835	5-19
74776	5-11	74836	5-17
74777	5-11	74837	5-9
74778	5-11	74838	5-12
74779	5-11	74839	5-13
74780	5-11	74840	5-13
74781	5-11	74841	5-15
74782	5-11	74842	5-15
74783	5-11	74843	5-9
74784	5-11	74844	5-19
74785	5-11	74845	5-19
74786	5-11	74846	5-5
74787	5-11	74847	5-9
74788	5-11	74848	5-11
74789	5-15	74849	5-19
74790	5-15	74850	5-19
74791	5-15	74851	5-15

CROSS REFERENCE

Part Number	Page Number	Part Number	Page Number
74852	5-19	75724	5-19
74853	5-7	75725	5-19
74854	5-3	75727	5-19
74855	5-9	75729	5-17
74856	5-9	75731	5-11
74857	5-3	75739	5-7
74858	2-3, 5-16	75741	5-17
74859	5-3, 5-5	75768	2-57, 2-59
74860	5-19	75794	5-22
74861	5-19	75804	5-22
74862	5-19	75805	5-23
74863	2-3, 5-19	75820	3-43
74864	5-19	75821	3-45
74865	5-19	75822	3-43
74867	2-49	75823	3-43
74868	2-49	75824	3-43
74899	2-115, 3-31	75825	3-43
75010	2-5	75827	2-49
75011	2-5	75828	3-57
75012	2-41, 2-43	75843	2-49
75022	3-31	75852	2-41
75023	3-31	75854	2-71
75028	2-113	75855	2-71
75046	2-45, 2-47	75857	2-115, 3-31
75047	2-45, 2-47	75859	2-115, 3-31
75082	3-31	75860	2-17
75092	3-31	75866	3-53
75099	3-35	75870	3-31
75117	3-35	75875	3-51
75128	2-19, 2-21, 3-65	75876	3-59, 3-61
75142	3-35	75877	3-59, 3-61
75192	3-51	75880	3-49
75282	3-31	75881	3-49
75303	3-65	75882	3-49
75304	3-51	75883	3-65
75305	2-95	75884	3-53, 3-55
75456-1	2-127, 2-129	75890	3-51
75456-2	2-127, 2-129	75891	2-33, 2-35
75456-3	2-127, 2-129	75892	3-31
75456-4	2-127, 2-129	75893	2-115
75456	2-127, 2-129	75894	2-115, 3-31
75465	2-55, 3-73	75899	3-35
75491	3-31	75901	3-63
75537	3-31	75968	2-133
75568	3-15, 3-16	75989	3-63
75573	3-11, 3-13	76030	3-63
75575	2-93	76036	3-63
75603	2-67	76038	3-63
75606	3-51	76049	3-63
75609	3-51	76055	3-63
75612	2-119	76069	3-63
75666	3-51, 3-65	76074	3-63
75667	2-49	76081	3-63
75689	3-23	76084	3-63
75701	3-59, 3-61	76100	3-63
75709	5-19	76235	2-31
75710	5-19	76237	2-31
75714	5-19	76245	3-55
75715	5-19	76270	3-53
75723	5-19	76285	2-17

CROSS REFERENCE

Part Number	Page Number	Part Number	Page Number
76286	3-59, 3-61	76971	3-43
76297	3-53	76973	3-43
76316	2-105	76975	3-45
76319	2-63, 2-65	76976	3-45
76321	2-63, 2-65, 3-65	76977	3-43
76335	2-63, 2-65	76980	3-43
76338	3-59, 3-61	76982	3-43
76339	2-115	76985	3-43
76382	2-67	76996	3-43
76383	2-67	77097	2-41, 2-43, 2-107, 2-117, 2-121, 2-131, 3-33
76384	2-39	77340	2-17
76385	3-41	77388	2-47
76404	3-11, 3-13, 3-15	77390	2-47
76406	3-59, 3-61	77391	2-47
76415	3-15, 3-16	77392	2-47
76427	2-95, 3-15, 3-16	77392	2-47
76437	3-53, 3-55	77394	2-47
76438	2-113	77400	2-47
76448	3-21	77423	3-15
76453	2-95	77424	2-59
76460	3-15	77430	2-59
76461	3-35	77434	2-59
76464	2-9	77435	2-59
76465	2-9	77436	2-59
76470	2-31	77447	2-77
76471	2-31	77452	2-77
76473	3-53	77458	3-33
76474	2-39	77459	2-117, 3-33
76487	2-39	77462	2-71
76490	2-93	77463	2-31
76491	2-93	77467	2-25
76492	2-17	77470	2-25
76495	2-17	77471	2-53
76497	2-101, 2-103	77473	2-103
76498	2-101, 2-103	77475	2-23
76499	2-101	77479	2-51
76522	3-43	77481	2-59
76523	2-95	77482	2-51
76529	2-43	77485	2-111
76555	2-9	77488	2-111
76575	3-19, 3-23	77489	3-65
76578	3-19, 3-23	77490	2-85
76615	2-101	77491	2-111
76619	2-115	77492	2-111
76620	2-65	77493	2-111
76639	2-93	77495	2-111, 4-37
76647	2-95	77498	2-111
76653	2-93	77499	2-111
76684	3-38, 3-39	77516	2-51
76736	2-71	77517	4-45, 4-47
76870	3-65	77519	3-28
76871	2-51	77520	3-28
76895	2-51	77523	2-51
76898	3-49	77527	2-81
76906	2-105	77528	2-77
76907	2-71	77529	2-77
76936	2-43	77530	2-81
76945	3-23	77531	2-129
76948	3-43	77532	2-129
76950	3-43	77537	3-25

CROSS REFERENCE

Part Number	Page Number	Part Number	Page Number
77538	3-25	77738	3-33
77542	3-25	77742	3-23
77545	3-28	77743	3-19
77552	2-71	77755	3-63
77553	2-129	77759	3-63
77555	3-57	77765	3-65
77556	2-71	77770	2-89
77557	2-71	77771	2-117, 3-33
77558	2-71	77773	3-65
77559	2-71	77777	2-9
77560	2-71	77778	3-65
77568	2-117, 3-33	77780	2-35
77569	3-33	77782	2-9
77575	2-107	77783	3-33
77578	2-125	77788	2-81
77579	2-85	77789	2-59
77580	2-125	77790	2-89
77584	2-117, 3-33	77800	3-47
77591	2-129	77801	3-47
77593	2-9	77802	3-47
77597	2-117, 3-33	77803	3-47
77599	2-117, 3-33	77804	3-47
77600	2-117, 3-33	77805	3-47
77601	2-117	77806	3-47
77602	2-85	77807	3-47
77605	2-117, 2-125	77808	3-47
77611	3-26	77809	3-47
77613	3-26	77810	3-43
77628	3-53	77811	3-43
77629	3-25	77812	3-43
77630	2-25	77813	3-43
77631	3-19, 3-23	77814	3-43
77632	2-3	77815	3-43
77633	2-3	77816	3-45
77634	2-3	77817	3-45
77640	2-103	77818	3-45
77641	2-103	77819	3-45
77642	2-25	77820	3-45
77646	2-93	77821	3-45
77662	3-25	77822	3-45
77665	3-23	77823	3-45
77669	2-117	77824	3-45
77670	3-25	77825	4-45, 4-49
77671	3-25	77826	4-45, 4-49
77674	3-53	77827	4-45, 4-47, 4-49, 4-51
77675	3-53, 4-45	77828	4-45, 4-47, 4-49, 4-51
77677	2-148	77829	4-45, 4-47
77682	2-117	77830	4-45, 4-47, 4-49, 4-51
77693	2-117	77831	4-45, 4-47
77703	3-65	77832	4-45, 4-47, 4-49, 4-51
77704	3-65	77833	4-45, 4-47
77706	3-65	77834	4-49, 4-51
77707	3-65	77835	4-45, 4-47, 4-49, 4-51
77708	3-65	77839	4-45, 4-47, 4-49, 4-51
77710	3-65	77840	4-45, 4-47
77712	3-65	77841	4-45, 4-47, 4-49, 4-51
77726	3-36	77842	4-45, 4-47, 4-49, 4-51
77727	2-117, 3-33	77843	4-45, 4-47
77728	2-21	77844	4-45, 4-47
77734	2-9	77845	4-45, 4-47

CROSS REFERENCE

Part Number	Page Number	Part Number	Page Number
77846	4-45, 4-47, 4-49, 4-51	79624	3-65
77847	4-45, 4-47, 4-49, 4-51	79625	3-65
77848	4-45, 4-47	79626	3-65
77849	4-45, 4-47, 4-49, 4-51	79642	2-103
77869	3-53	79644	3-61
77872	4-45, 4-47, 4-49, 4-51	79646	3-61
78043	2-71	79647	3-61
78996	2-107, 4-33	79650	3-23
78997	2-65	79674	3-61
78998	3-39	79676	2-9
78999	2-87, 2-89	79680	2-9
79002	2-21	79688	4-45, 4-47, 4-49, 4-51
79009	2-21	79689	4-45, 4-47
79010	2-9	79690	4-49, 4-51
79012	3-19	79692	4-45, 4-47, 4-49, 4-51
79019	2-47	79694	4-45, 4-47, 4-49, 4-51
79025	3-73	79695	4-45, 4-47
79026	3-73	79697	4-45, 4-47
79028	2-17, 2-125	79698	4-45, 4-47
79032	2-3	79699	4-45, 4-47
79115	2-117, 3-33	79703	4-3, 4-11
79116	2-95	79704	4-5, 4-13
79117	2-117	79705	4-5, 4-13
79122	2-129	79706	4-3, 4-11
79123	2-113	79707	4-3, 4-11
79124	3-35	79708	4-9, 4-17
79138	2-43	79709	4-3, 4-5, 4-11, 4-13
79139	2-39	79711	4-28, 4-29, 4-31, 4-33, 4-35
79140	2-87	79719	4-29, 4-31, 4-33, 4-35
79151	2-89	79720	4-31, 4-33
79153	2-87, 2-89	79728	4-29, 4-31, 4-33, 4-35
79155	3-73	79731	4-28, 4-31, 4-33, 4-35
79156	3-73	79739	4-28, 4-31, 4-33, 4-35
79157	3-73	79740	4-28, 4-29, 4-31, 4-33, 4-35
79158	3-73	79742	4-3, 4-7, 4-11, 4-15
79159	3-73	79743	4-7, 4-15
79160	3-73	79744	4-7, 4-15
79167	3-73	79745	4-7, 4-15
79168	3-73	79746	4-7, 4-15
79169	3-73	79747	4-7, 4-15
79170	3-73	79748	4-5, 4-9, 4-13, 4-17
79172	3-73	79749	4-5, 4-9, 4-13, 4-17
79174	3-73	79750	4-5, 4-9, 4-13, 4-17
79176	3-73	79751	4-5, 4-9, 4-13, 4-17
79177	3-73	79752	4-5, 4-9, 4-13, 4-17
79181	2-51	79753	4-5, 4-9, 4-13, 4-17
79399	2-59	79754	4-41
79513	3-11, 3-13, 3-16	79755	4-39, 4-41
79514	2-87	79756	4-39, 4-41
79554	3-16	79757	4-39, 4-41
79587	2-47	79758	4-39, 4-41
79591	2-47	79759	4-41
79593	2-93	79760	4-39, 4-41
79594	2-93	79761	4-39, 4-41
79596	2-43	79762	4-39, 4-41
79597	2-39	79763	4-39, 4-41
79600	2-39	79764	4-39, 4-41
79620	3-65	79765	4-39, 4-41
79621	3-35		
79622	3-35		

CROSS REFERENCE

Part Number	Page Number	Part Number	Page Number
79766	4-39, 4-41	83618	2-43
79767	4-39, 4-41	83620	2-51
79771	4-7, 4-15	83622	2-51
79772	4-39	83626	3-29
79773	4-39	83627	3-29
79774	4-39	83644	2-71
79775	4-39	83694	2-148
79776	4-39, 4-41	83695	2-148
79777	4-39	83699	3-37
79778	4-39	83706	3-73
79779	4-3, 4-7, 4-11, 4-15	84014	2-107, 4-35
79781	2-113, 3-35, 4-22	84015	2-131, 3-35, 4-28
79782	4-22	84016	2-117, 3-33, 4-29
79783	4-43	8527-77-739	5-7
79784	4-43	85308	3-74
79786	4-37	8599-15-173	5-17
79787	4-37	8599-24-712	5-21
79788	4-37	8599-24-721	5-21
79789	4-37	8599-24-722	5-21
79790	4-37	8599-24-727	5-21
79791	4-37	8599-24-731	5-21
79792	4-37	8599-24-740	5-21
79793	4-37	8599-24-741	5-21
79794	4-37	8599-24-743	5-21
79795	4-37	8599-24-744	5-21
79797	4-37	8599-24-746	5-21
79798	4-37	8599-24-750	5-21
79799	4-37	8599-24-752	5-21
79812	4-37	8599-24-761	5-21
79820	4-37	86034	2-93
79822	4-37	86328	2-113, 3-35
79823	4-37	86331	3-3, 3-5, 3-7, 3-9
79824	4-37	86333	3-15
82063	3-3, 3-7, 3-11	86860	2-7
82125	2-7, 2-9	86953	2-95
82168	2-95	87246	2-57, 2-59, 3-21, 3-25
82200	3-5, 3-9, 3-13	87337	3-70
82334	2-19	87396	2-69, 2-71
82509	2-71	87414	2-105
82661	2-67	87515	2-7, 2-9
82682	2-69	87536	2-135
82692	2-69	87583	2-137
82731	2-61, 3-25	87631	2-119
82733	2-131	87866	2-135
82739	2-55, 3-73	8AW3-15-100B	5-17
82814	2-101	8AW4-10-431	5-7
82820	2-101, 2-103	90796-0816	5-15
82825	2-41, 2-43	90797-2525	5-15
82839	2-95	99222-0308	5-3
82843	2-101, 2-103	99233-0616	5-5
82921	2-17	99233-0818	5-7
82962	3-59, 3-61	99233-0822	5-9
83547	2-51	99233-1228	5-5
83548	2-51	99234-0855	5-7
83549	2-31	99234-1212	5-7
83551	2-31	99234-1618	5-5
83553	2-31, 2-35	99236-0545	5-9
83554	2-31, 2-35	99239-0316	5-15
83555	2-35	99276-1808	5-17
83557	3-29	99283-0900	5-15

CROSS REFERENCE

Part Number	Page Number	Part Number	Page Number
99283-1500	5-5	99852-0840	5-5
99306-1000	5-11	99852-0868	5-5
99306-2500	5-3, 5-5	99853-0510	5-7
99306-3000	5-3, 5-5	99859-1016F	5-3
99306-4000	5-5	99868-0408	5-3
99306-4950	5-3	99922-0800	5-11
99381-10800	5-15	99940-0500	5-15
99502-1000	5-13	99940-0801	5-7, 5-12, 5-15
99503-1000J	5-3, 5-5	99940-1000	5-15
99503-3000	5-19	99951-0822	5-19
99510-2400	5-19	99958-1220	5-11
99511-1000	5-22	99971-0500	5-7
99511-1200	5-7		
99541-01605	5-19		
99562-1000	5-22		
99564-1200	5-7, 5-15		
99564-1400	5-7		
99564-2400	5-19		
99573-2000	5-17		
99574-4700	5-17		
99576-1200	5-11		
99606-22020	5-9		
99606-92040	5-17		
99611-1500	5-16		
99769-0620	5-15		
99781-1235	5-11		
99784-0812	5-9		
99789-0825A	5-3		
99789-0845A	5-3		
99789-0848	5-3		
99796-0625	5-19		
99796-0630	5-19		
99796-0801	5-19		
99796-0816	5-3, 5-11		
99796-0820	5-7, 5-12, 5-19		
99796-0825	5-7, 5-12, 5-17, 5-19		
99796-0830	5-7, 5-9		
99796-0840	5-3		
99796-0845	5-3		
99796-0850	5-7, 5-11		
99796-0855	5-7, 5-17		
99796-0865	5-7		
99796-0870	5-7		
99796-0880	5-17		
99796-1016	5-15		
99796-1020	5-3, 5-15		
99796-1028	5-7		
99796-1035	5-7, 5-19		
99796-1050	5-19		
99796-1060	5-19		
99796-1095	5-3		
99796-830	5-17		
997967-0812	5-7		
99800-08110	5-7		
99800-08120	5-7		
99800-08130	5-7		
99852-0812G	5-7		
99852-0818A	5-3		
99852-0822	5-5		
99852-0825G	5-7		

PART DESCRIPTION TO PAGE NUMBER CROSS REFERENCE LIST

A

A/C Hose #10 R12 De, 3-53
 A/C Hose #6 134A De, 3-53
 A/C Hose #6 R12 De, 3-53
 A/C Hose #8 R12 De, 3-53
 Actuator, Valve En, 4-9, 4-17
 Actuator, Valve En, 4-5, 4-13
 Adapter, Filter 1/8 Npt, 2-63
 Adaptor Weldm., Side Brush 1.0B, 2-5
 Adaptor Wldt, Vac Wand, 3-59, 3-61
 Adaptor, Filter, 1/8 Npt, 2-65, 3-65
 Adaptor, Neutral En, 4-39
 Air Cleaner Assy, Air Cond, 3-51
 Air Cleaner, 2-63, 2-65, 3-65
 Air Conditioner 134R Recirc (See Breakdowns),
 3-53
 Air Conditioner 134R Recirc, 4-47
 Air Conditioner, A 134 (Repl. By 21270) (See
 Breakdowns), 3-53
 Air Conditioner, A 134 (Repl. by 21270), 4-45
 Alternator, 50A, Sealed Brushes, 2-61
 Alternator, 3-57
 Alum. Dryer Line De, 4-45, 4-47
 Angle, Bolt, Latch, Cover, 2-19, 2-21
 Angle, Bolt, Latch, 2-23, 2-25
 Angle, Cable Keeper, 2-115, 3-31
 Angle, Dust Seal, 2-37, 2-39
 Angle, Mount, 2-47
 Angle, Mtg, Shroud, Lh, 2-79
 Angle, Mtg, Shroud, Rh, 2-79
 Angle, Retainer, Lip, 2-37, 2-39
 Angle, Retainer, Seal, 2-11, 2-13
 Angle, Stiffener, 2-75
 Angle, Top, 2-75
 Angle, 3-61
 Arm Wldt, Hopper Lift, 2-29, 2-31
 Arm Wldt, M Br, Idler, 2-119
 Arm Wldt, M Br, Motor, 2-119
 Arm, Control En, 4-3, 4-7, 4-11, 4-15
 Arm, Couple, 3-21
 Arm, Rear Wiper, 3-43

Arm, Rocker, 5-11
 Arm, Safety, 2-29, 2-31
 Arm, Wldt, Outlet, 3-21
 Armature, 5-21

B

Back Plate Assembly, 4-18
 Backplate S/A En, 4-9, 4-17
 Backplate S/A En, 4-5, 4-13
 Ball En, 4-39
 Ball Joint .375-24, 3-59
 Ball Joint .375-24, 3-61
 Ball Joint, 250-28, 2-95, 3-25
 Ball, Check Cl, 4-25
 Ball, Check, 5-16
 Ball, Steel, 5-19
 Ball, 4-19
 Balljoint .375-24 Lh, 3-59
 Balljoint .375-24 Lh, 3-61
 Balljoint M 6X1.0, 2-19
 Balljoint, Rod End, 2-87
 Band, Mtg., 2-63, 2-65, 3-65
 Bar Wldt, Brush Pressure, 2-119
 Bar Wldt, Pivot, 2-95
 Bar, Arm, Lower, Machining, 2-31
 Bar, Cylinder End, 2-33, 2-35
 Bar, Equalizer, 2-93
 Bar, Frame, 2-9
 Bar, Lower Arm, Machining, 2-29
 Bar, Prop, 3-59, 3-61
 Bar, Retainer, Dust Seal, 2-37, 2-39
 Bar, Retainer, 2-17
 Bar, Shaker Stem, 2-53
 Battery, 12V, Cc Amps:730 Wet, 2-83
 Battery, 12V, Wet, 2-85
 Bearing Thrust, 4-21, 4-22
 Bearing, Control Shaft, 2-109
 Bearing, Fiberglide .50 X .50, 2-53
 Bearing, Fiberglide, 2-95
 Bearing, Flange .500B, 2-133
 Bearing, Flange .625 Bore, 2-45, 2-47, 3-59, 3-61

CROSS REFERENCE

Bearing, Flange .875 Bore, 2-113, 3-35
Bearing, Flywheel, 5-9
Bearing, Journal, 2-33, 2-35, 2-41, 2-43
Bearing, Needle, 4-25, 4-26
Bearing, Nylon .50B, 2-111
Bearing, Nylon, 2-45, 2-47, 3-73
Bearing, Self Aligning, 2-115, 3-31
Bearing, Thrust .500, 2-7
Bearing, Thrust – Fiberglide, 2-53
Bearing&Clr , 1.25B 2.44D 1.41W, 2-119
Bearing–Ball, 1.38B 2.83D 0.67W, 2-119
Bearing–Cone, 1.38Bore 0.72Wth, 2-89
Bearing–Cone, 1.50Bore 0.75Wth, 2-89
Bearing–Cone, 2.63Bore 0.87Wth, 2-87
Bearing–Cup , 4.33Dia 0.74Wth, 2-87
Bearing–Cup, 2.56Dia 0.55Wth, 2-89
Bearing–Cup, 2.72Dia 0.59Wth, 2-89
Bearing–Flange, 2 Hole 0.50Bore, 2-133
Bearing–Journal, 2-29, 2-31, 2-33, 2-35
Bearing, 2-53, 2-113, 2-115, 2-117, 3-31, 3-33,
3-35, 4-3, 4-5, 4-7, 4-9, 4-11, 4-13, 4-15, 4-17,
4-20, 5-17
Bearng–Journal, 2-29, 2-31
Bell Crank En, 4-39
Bell Crank, 4-41
Belt, Seat, 3-70
Belt, Vhc–50 X 61, 3-53
Binary Press. Switch, 4-45, 4-47
Blade Arm, Rear, 3-43
Blade, Deflector, 2-3, 2-7, 2-9
Block, Cylinder, 5-5
Block, Oil Pan Upper, 5-7
Block, 3-33
Blower, 4-45, 4-47, 4-49, 4-51
Body and Gear Kit, .50 CIR, 4-18
Body and Gear Kit, .66 CIR, 4-18
Body, Water Pump, 5-17
Bolt Carr.38–16X2.00, 2-75
Bolt Set, 5-21
Bolt, Bearing Cap, 5-5
Bolt, Connecting Rod, 5-9
Bolt, Cylinder Head, 5-3
Bolt, Hook, Rh, 2-19, 2-21
Bolt, Latch, 2-11, 2-13
Bolt, Lock, Flywheel, 5-9
Bolt, Pulley, 5-9
Bolt–Eye M8–1.25, 2-113, 3-35
Bolt, 4-19, 5-3, 5-5, 5-7, 5-9, 5-11, 5-12, 5-15,
5-17, 5-19
Boot, Alternator, 2-61
Boot,Batt.Term. 1–2Ga. Red, 2-83
Boot,Batt.Term.1–2Ga. Black, 2-83
Boot–Circuit Breaker, 2-137
Boss, Water Pump Pulley, 5-17
Box, A/C (Repl. by 21281), 4-45
Box, A/C, 4-47, 4-49, 4-51
Box, Mounting, Lever, Vac, 3-61
Brace Wldt, Bumper, Se, 3-27, 3-28, 3-29
Brace, 3-53
Bracket Wldt, Cab, Lpg, 3-43
Bracket Wldt, Fan Inlet, 2-127, 2-129
Bracket Wldt, Gas Spring, 2-19
Bracket Wldt, Lift, Cylinder, 2-121
Bracket Wldt, Lift, 3-35
Bracket Wldt, Mounting, Valve, 2-111
Bracket Wldt, Mtg, Die, Lh, 2-59
Bracket Wldt, Mtg, Die, Rh, 2-59
Bracket Wldt, Mtg, Headlight, 2-51
Bracket Wldt, Mtg, Valve, 2-109
Bracket Wldt, Mtg,Headlamp,Lh (Replaced by
77388), 2-45
Bracket Wldt, Mtg,Headlamp,Rh (Replaced by
77388), 2-45
Bracket Wldt, Oper Comp, 2-15
Bracket Wldt, Pivot, 3-35
Bracket Wldt, Steering Tilt, 2-133
Bracket Wldt, 3-19, 3-23, 3-31, 3-63, 3-65
Bracket, Accel Cable, 5-7
Bracket, Adjuster, Brake, 2-93
Bracket, Adjusting, Spring, 2-95
Bracket, Air Cleaner, Die, 2-63, 2-65
Bracket, Alternator, Machined, 2-61
Bracket, Angle, 2-113, 3-33, 3-35, 3-41
Bracket, Battery, 2-85
Bracket, Blower Mount, 4-45, 4-47, 4-49, 4-51
Bracket, Brace, Center, 2-19, 2-21

Bracket, Brush Lift, Main, 2-121
Bracket, Cable Keeper, 2-115, 3-31
Bracket, Center, 5-21
Bracket, Channel, 2-115, 3-19, 3-31
Bracket, Flasher, 3-15, 3-16
Bracket, Front, Lh, 3-65
Bracket, Front, Rh, 3-65
Bracket, Fuel Filter, 5-15
Bracket, Hose, Blower, 3-19, 3-23
Bracket, L. H., 2-45
Bracket, L, 2-41
Bracket, Lh, 2-47
Bracket, Lift, 2-113
Bracket, Mounting Dir Cont, 2-95
Bracket, Mounting Filter, 2-81
Bracket, Mounting Motor, 2-131
Bracket, Mounting, Compressor, 3-53
Bracket, Mounting, Eng, Rear, 2-59
Bracket, Mounting, Eng,Rear Lh, 2-59
Bracket, Mounting, Filter, Fro, 3-65
Bracket, Mounting, Gearmotor, 3-73
Bracket, Mounting, Headlamp, 2-47
Bracket, Mounting, Lever, 3-21
Bracket, Mounting, Mirror, 3-49
Bracket, Mounting, Motor, 2-59, 2-113, 3-35
Bracket, Mounting, Skirt, 3-63
Bracket, Mounting,Alarm Switch, 2-95, 3-15, 3-16
Bracket, Mounting, 2-107
Bracket, Mtg, Air Cleaner, 2-63, 2-65
Bracket, Mtg, Battery, 2-85
Bracket, Mtg, Engine, Rear, 2-59
Bracket, Mtg, Filter, 2-79
Bracket, Mtg, Ftg, 2-41, 2-43
Bracket, Mtg, Motor, 2-57
Bracket, Mtg, Ohg, 3-17
Bracket, Mtg, Pulley, 3-31
Bracket, Mtg, Shroud, Lh, 2-81
Bracket, Mtg, Shroud, Lower, 2-77
Bracket, Mtg, Shroud, Rh, 2-81
Bracket, Mtg, Shroud, Upper, 2-77
Bracket, Mtg, Skirt, 2-37, 2-39
Bracket, Mtg, Switch, 2-49
Bracket, Mtg, Valve, 2-131
Bracket, Oil Pipe, 5-7
Bracket, Oil Strainer, 5-7, 5-19
Bracket, Oper Comp, 2-17
Bracket, Pivot, 2-113, 3-31
Bracket, Pump, Fuel, 2-71
Bracket, R. H., 2-45
Bracket, Rear, Se, 3-65
Bracket, Rear, 5-21
Bracket, Rh, 2-47
Bracket, Rocker Arm, 5-11
Bracket, Rocker, 5-11
Bracket, Side Brush, Valve, 3-33
Bracket, Spring, 2-113, 3-35
Bracket, Steering, Machining, 2-87
Bracket, Support, Blower, 3-19, 3-23
Bracket, Switch, A/C, 4-45, 4-47
Bracket, Tail Pipe, 2-67
Bracket, Tailpipe, 2-67
Bracket, Throttle Cable, Die, 2-57, 2-59
Bracket, Tube, 2-73
Bracket, Water Separator, 2-71
Bracket, 2-7, 2-63, 2-65, 2-83, 2-115, 3-3, 3-5, 3-7, 3-9, 3-15, 3-16, 3-25, 3-45, 3-63, 3-65
Brake Assy, Lh, 2-89
Brake Assy, Rh, 2-89
Brake, Hand, Replmt Kit, 2-93
Brake, Hyd, Lh (Repl. by 77770), 2-89
Brake, Hyd, Rh (Repl. by 77790), 2-89
Breaker–Circuit, 2.5 Resetbl, 2-137
Breaker–Circuit, 15 Resetbl, 2-137
Breaker–Circuit, 30 Thermal, 3-53
Breather Cap and Gasket, 2-105
Breather, Hyd 40Mic No DS, 2-3
Breather, Hyd, 2-105
Brkt Wildt , Gas Spring, 2-21
Brush, Yoke, 5-21
Brush–Outsd Spl–50Lg – 8Dr–Poly, 2-5
Brush–Patrl Spl–50Lg – 4Qr–Nyl, 2-5
Brush–Side Swp –26 D–Assy–Fltw, 2-5
Brush–Side Swp –26 D–Assy–Nyl, 2-5
Brush–Side Swp –26 D–Assy–Poly, 2-5
Brush–Side Swp –26 D–Fltw, 2-5

Brush-Side Swp -26 D-Nyl, 2-5
Brush-Side Swp -26 D-Poly, 2-5
Brush-Sweep Spl-50Lg - 8Dr-Poly, 2-5
Brush-Sweep Spl-50Lg-24Sr-Nyl, 2-5
Brush-Sweep Spl-50Lg-8Dr-P&W, 2-5
Brush-Sweep Spl-50Lg-8Dr-Wire, 2-5
Bshg,Flange,0.62Bx0.68Od,Nylon, 3-49
Bulb, 12V .2A 32Cp #1156, 3-11, 3-13
Bulb, 12V .5A 4CP#1157, 2-7
Bulb, 12V .5A 4Cp #1157, 2-9
Bulb, 12V .9A, 3-15, 3-16
Bulb, 12V, 3-3, 3-5, 3-7, 3-9
Bumper Assy, Se, 3-27, 3-28, 3-29
Bumper Wldt, Front, Rh, 2-51
Bumper Wldt, Front, 2-49
Bumper Wldt, Lh, 2-51
Bumper Wldt, Rear, 2-7
Bumper Wldt, Rh, 2-51
Bumper Wldt, Se, Rh, Front, 3-28, 3-29
Bumper Wldt, Sppt, Hopper, Rh, 2-51
Bumper Wldt,Se, Lh, Front, 3-28, 3-29
Bumper, 3/32 Matl., 3-15
Bumper, Corner, Mach, 2-7, 2-9
Bumper, Cover, Hopper, 2-47
Bumper, Front, Machining, Lh, 2-49
Bumper, Front, Machining, Rh, 2-49
Bumper, Rubber, 2-15, 2-17, 2-27, 2-45, 2-47,
3-7, 3-9, 3-21
BumperWldt, Rear, (Gas/Die), 2-9
Bushing En, 4-7, 4-15
Bushing En, 4-5, 4-9, 4-13, 4-17, 4-37
Bushing, Connecting Rod, 5-9
Bushing, Idle Gear, 5-11
Bushing, Isolator-Inner,Rbr., 2-109, 2-111
Bushing, Isolator, 2-53, 2-75, 2-77, 2-127, 2-129
Bushing, Rocker Arm, 5-11
Bushing, Seal, 4-25, 4-26

C

Cab Body, 3-43
Cable Assy, Side Brush, Lift, 2-115, 3-31
Cable Assy-Batt,Pos, 48.0, 2Ga, 2-85
Cable Assy, 3-21
Cable Tie Mount, 3-3, 3-5, 3-7, 3-9
Cable, Bowden, 4-45, 4-47, 4-49, 4-51
Cable, Brake, Park, 2-93
Cable, Lift, Main Brush, 2-121
Cable, Push,Pull, 2-95
Cable, Retaining, Side Brush, 2-113, 3-35
Cable, Retaining, 2-49
Cable, Side Brush, Lift, 2-117, 3-33
Cable, Speed Control, 2-95
Cable, Throttle, 2-57, 2-59
Cabletie Mount, Adhesive, 3-11, 3-13
Cam Bushing En, 4-3, 4-11
Cam Wldt, 2-95
Cam, Adjuster, 2-49
Camplate Cradle En, 4-3, 4-11
Camplate S/A En, 4-3, 4-7, 4-11, 4-15
Camshaft, 5-11
Cap Assembly En, 4-37
Cap Radiator, 2-77
Cap Screw En, 4-7, 4-15
Cap Screw Cl, 4-25
Cap Screw, 4-21, 4-22
Cap, Bleeder Screw, 5-16
Cap, End Cl, 4-25
Cap, End, 4-26
Cap, Fuel, 2-71
Cap, Gas, 2-69
Cap, Grease Black Paint, 2-89
Cap, Oil Filler, 5-3
Cap, Radiator 7 Psi, 2-75
Cap, Screw, 4-26
Cap, Valve Stem, 2-91
Cap, Valve, 5-11
Cart Flow Control CP, 4-31, 4-33, 4-35
Cart, Check Valve CP, 4-31, 4-33, 4-35
Cart, Pilot CNTR CP, 4-31
Cart, Pilot Cntr, 4-29

Cart, PSI CN CP, 4-31, 4-33, 4-35
Case Front Cover (Repl. by 21281), 4-45
Case Front Cover, 4-49
Case, Timing Gear, 5-7
Casing, Thermostat, 5-3
Chain, Link#2/0, 7Links, 2-3
Chain,#12Jack Type 6.0Lg, 3-59, 3-61
Chain,Link#2/0,7Links, 2-7, 2-9
Channel Wldt, Blower Wand, 3-11, 3-13, 3-16
Channel Wldt, Fan Motor, 2-79, 2-81
Channel Wldt, Mtg, Engine,Rear, 2-57, 2-59
Channel Wldt, Mtg, 2-7
Channel Wldt, 2-75
Channel, Hinge, Filter Cover, 3-65
Channel, Mounting, 2-9
Channel, Mtg, Steering Latch, 2-133
Channel, Retainer, Seal, Rear, 2-3, 2-7
Channel, Retainer, Seal,Rear, 2-9
Channel, Retainer, 2-3, 2-7, 2-9, 2-87
Channel,, 3-11, 3-13, 3-15
Charge Pmp Adap En, 4-5, 4-9, 4-13, 4-17
Check Kit, Pilot, 4-36
Check Valve, 100 Psi, 3-35
Clam Latch, 3-45
Clamp Wldt, Tube, Blower Wand, 3-19, 3-23
Clamp, 3.250 Id, 3-19, 3-23
Clamp, Cable 1.5 Dia, 2-113, 3-35
Clamp, Cable– Brake, 2-93
Clamp, Cable, 2-63, 2-65, 2-87
Clamp, Mtg, Motor, Upper, 2-53
Clamp, Worm Drive 3.62–5.50, 2-127
Clamp,Cable .44D .62Wide, 3-73
Clamp–Cable, .69Dia. .62Wth, 2-69
Clamp–Cable, 0.25Dia 0.56Wth, 2-93, 3-73
Clamp–Cable, 0.38Dia 0.38Wth, 3-59, 3-61
Clamp–Cable, 0.38Dia 0.62Wth, 2-71
Clamp–Cable, 0.56Dia 0.38Wth, 2-55, 2-69
Clamp–Cable,.69Dia. 62Wth, 2-35, 2-71
Clamp–Cable, 2-33
Clamp–Muffler,For 1.87 Od Tube, 2-67
Clamp–Muffler,For 2.00 Od Tube, 2-67
Clamp–Wormdrive, 0.25– 0.62D, 2-71, 3-65
Clamp–Wormdrive, 0.31– 0.88D, 2-59
Clamp–Wormdrive, 1.06– 2.00D, 2-73
Clamp–Wormdrive, 1.56– 2.50D, 2-73
Clamp–Wormdrive, 1.62– 3.50D, 2-53, 2-63, 2-65, 3-19, 3-23, 3-25, 3-51, 3-65
Clamp–Wormdrive, 1.81– 2.75D, 2-63, 2-65
Clamp–Wormdrive, 2.63– 4.50D, 2-129, 3-19
Clamp–Wormdrive, 3.62– 5.50D, 2-129
Clamp, 5-5, 5-15, 5-17
Clevis,Adjust.0.25–28Th.Cad., 2-95, 3-25
Clip Finger Grip, 3-59, 3-61
Clip Safety, 2-21
Clip, Injection Pipe, 5-15
Clip, Mercury Switch, 2-49
Clip, Pipe, 5-15
Clip, Safety, 2-19
Clip, 5-3, 5-15
Closure, 3-43
Coil 12V w/Var CP, 4-35
Coil 12V CP, 4-31, 4-33
Coil 12Vdc, 4-27
Coil, 12V W/Var, 4-28, 4-29
Collar, Clamping, 2-33
Column, Steering 12”, 2-133
Compressor R12, 3-53
Compressor, A/C, 3-53
Condensor, Air Conditioner, 3-53
Control Assy CI, 4-25
Control Unit, 5-22
Control, Manual (see Breakdown), 4-3, 4-7, 4-11, 4-15
Control, Manual, 4-41
Controller Assy, Rfs, 3-73
Cooler, Oil, 5-19
Cooler–Hyd, 2-27
Cord, Glow Plug, 5-22
Core, Heating/Cooling, 4-45, 4-47, 4-49, 4-51
Cotter, Valve, 5-11
Coupler En, 4-5, 4-9, 4-13, 4-17
Coupling Assy, Flywheel, 2-57
Coupling Flywheel, 2-59
Coupling, 3-73
Cover Assy, Hopper, 2-45, 2-47

- Cover Set, 5-21
Cover Wldt, Air Cond Box, 3-51
Cover Wldt, Engine Se, 3-65
Cover Wldt, Engine, 2-19, 2-21, 3-19
Cover Wldt, Fuel Inlet, 2-15
Cover, A/C, 4-47, 4-51
Cover, Brake Kit, 2-93
Cover, Cab, Lpg, 3-43
Cover, Cylinder Head, 5-3
Cover, Electrical, 3-73
Cover, Housing, Electrical, 3-73
Cover, Injection Pump, 5-7
Cover, Motor, 3-73
Cover, Peep Hole, 5-7
Cover, Rear, 5-9
Cover, Relay Panel, 2-137
Cover, Rocker Switch Seal, 2-117, 2-135, 3-33
Cover, Thermostat, 5-17
Cover, Timing Gear, 5-7
Cover, 5-16
Cradle Sub Assy En, 4-7, 4-15
Cradle Wldt, Engine, Diesel, 2-57
Crankshaft, 5-9
Cylinder, Hyd (See Breakdowns), 2-33
Cylinder, Hyd (See Breakdowns), 2-87
Cylinder, Hyd , 2-41
Cylinder, Hyd 1.5B 1.5S 2500, 2-117, 3-33
Cylinder, Hyd 2.0B 11.6S 2500, 2-35
Cylinder, Hyd 2.0B 8.0S 2500, 2-43
Cylinder, Hyd 4.0B 14.5S 2500 (See Breakdowns), 2-35
Cylinder, Hyd 4.0B 14.5S 2500, 4-43
Cylinder, hyd. 2.0 B 14.9S 2500, 2-35
Cylinder, Hyd, 2-121
Cylinder, Hydraulic, 4-42
Cylinder, Master Brake, 2-93
- D**
- Dampner, Engine, 2-15, 2-17
Decal, 4-45, 4-47
Disc, 2-53
Disconnect, Male, 3-43
Disk, Adjusting, 3-59
Disk, 3-61
Door Cw, 3-45
Door Group, 3-45
Door Wldt, Brush, Lh, 2-11
Door Wldt, Brush, Rh, 2-13
Door Wldt, Engine Replacement Kit, 2-23
Door Wldt, Engine, 2-25
Door Wldt, Hopper, 2-41, 2-43
Door Wldt, Rear, 2-27
Door Wldt, 2-7
Dowel Bushing En, 4-7, 4-15
Dowel Pin En, 4-39
Dowel Pin, 4-41
Dowel, 5-5
Drain Cock, .25Npt Wh#120 Angl, 2-75
Drain Cock, .25Npt Wh#120 Angl, 2-77
Drain Pan De, 4-45, 4-47, 4-49
Drain Pan De, 4-51
Drain Pan Tube De, 4-45, 4-47
Drive Shaft, 4-18
Drive, Valve, 4-19
Drive, 4-19, 4-20, 4-21, 4-22, 4-25, 4-26
Drum Assy, Brake 9/16, 2-89
Drum, Brake, 2-89
Dryer Bracket De, 4-45, 4-47
Dryer, 4-45, 4-47
Duct Wldt, Rfs, 3-73
Duct, Fan, Ac, 3-53
Duct, Inlet, Vac Fan, 2-37, 2-39
Duct, Rear, 2-75, 2-77
Duct, Vinyl .40X .75X26.0 .25D, 3-3, 3-5, 3-7, 3-9
Duct, Vinyl .40X.75X3.5 .25D, 3-15
Duct, Vinyl 26.0", 3-15
Duct, Wldt, 3-21
Dust Control Kit, Side Brush, 3-63

E

Elbow, 90, Rubber, 2-129
 Elbow,90,Rubber 2.25Dia, 2-63, 2-65
 Elbow–Rubber,90Deg,2.5I.D., 2-63, 2-65
 Element Assy, 2-63, 2-65
 Element, Air Cleaner, 3-65
 Element, Filter Safety, 3-65
 Element, Filter, 2-81
 End Cap, 4-21, 4-22
 Engine Service Manual PK, 3-74
 Engine, Basic–4.154, 2-59
 Engine,Basic–Perkins, 4.154 (See Engine Breakdown), 2-57
 Expansion Block, 4-45, 4-47
 Extinguisher Kit Fire 800, 3-67
 Extinguisher, Fire, 3-67

F

Face Plate Ac/Heat, 4-45, 4-47
 Face Plate Heat De, 4-49, 4-51
 Fan, Radiator, 2-79, 2-81
 Fan, Repair Kit, Reassembly, 2-129
 Fender Washer, 2-11, 2-13
 Ferrule, 2-53
 Filter Assy, Spin–On 10Micron, 2-79
 Filter Assy, Spin–On, 2-81
 Filter Assy, Spin–on, 2-3
 Filter Assy,Replmt Kit F/65220, 2-81
 Filter Assy, 2-53
 Filter Element Dn, 2-79
 Filter Element,Diesel Fuel, 2-69
 Filter Sender Dn, 2-79
 Filter, Air, A/C, 3-51
 Filter, Fuel diesel, 2-71
 Filter, Fuel PK TFO1–13–ZA5, 2-3
 Filter, Fuel, Element, 2-71
 Filter, Fuel/Water Separator, 2-69
 Filter, Fuel, 2-71, 5-15, 5-16
 Filter, Oil PK TFYO–14–302, 2-3
 Filter, Oil, 5-19
 Filter, Pre–Cleaner, A/C, 3-51, 3-65
 Filter,Service Indicator, 2-63

Fitting, Banjo, 5-15
 Fitting, Brass E90, 2-71
 Fitting, Brass Em06/Pm02, 3-65
 Fitting, Brass Str, 3-55
 Fitting, Brs Spcl, 2-59
 Fitting, El 90Npt/Npt 04Pf, 2-71
 Fitting–Brs Str, 2-71
 Flange, Mounting, 4-20, 4-21, 4-22
 Flange,Brg,3 Hole, 2-119
 Flasher,12V.Ideal Co.Hd552Ps83, 3-15, 3-16
 Flat Washer, 3/8” Hard, 3-33
 Fluid, Hyd Oil, SHP 15/40 5Gal, 2-3
 Flywheel, 5-9
 Foam Case Insul De, 4-45, 4-47, 4-49, 4-51
 Foam, Door, 3-45
 Foam, Front Sill, 3-47
 Foam, Insulation, 3-17
 Foam, Lh Front Pos, 3-47
 Foam, Lh Rear Pos, 3-47
 Foam, Lh Side Sill, 3-47
 Foam, Rear Sill, 3-47
 Foam, Rh Front Pos, 3-47
 Foam, Rh Rear Pos, 3-47
 Foam, Rh Upper Sill, 3-47
 Follower, Piston, 4-7, 4-15
 Follower,Piston En, 4-3, 4-11
 Frame Assy–Door, 3-45
 Frame Asy–Cab, 3-43
 Frame Wldt , 2-7
 Frame, 2-9
 Frnt Glass Asy–Cab, 3-43
 Frnt Glass Asy–Door, 3-45
 Ftg, Breather, 2-55, 3-73
 Ftg, El90 Npt/02Pf–02Pm, 3-65
 Ftg, Grease .12Nptf–Str, 2-123
 Ftg, Grease.12 Npt 45 .88L, 2-125
 Ftg, Grease.25–28Th 90 .75L, 2-87
 Ftg,Brass,St Bm03/Pm02, 3-73
 Ftg,Brass,Tee 06lf– 02Pm– 06lf, 2-93
 Ftg,Bulkhead–Barb Wh 1074X4, 2-55, 3-73
 Ftg,Pipe,Cplg.Full 0.13Pt.Blk, 2-57, 3-65
 Ftg,Pipe,Cplg.Full 0.13Pt.Blk, 2-59

CROSS REFERENCE

Ftg,Pipe,Nip.Blk0.12Ptx 4.00Lg, 2-57, 2-59
Ftg-Brs E90 If05/Pm02, 2-71
Ftg-Brs If05/If05, 2-71
Ftg-Brs Str Bm03/Pm02, 2-55
Ftg-Brs Str If05/Pm02, 2-71
Ftg-Hyd Cap Jf08, 2-57, 2-59
Ftg-Hyd E45 Jm04/Om04, 2-87, 2-121
Ftg-Hyd E45 Jm08/Om08, 2-131
Ftg-Hyd E45 Jm20/Jf20, 2-97
Ftg-Hyd E45 Pm04/Jm06, 2-69
Ftg-Hyd E90 Jm04/Jf04, 2-33, 2-35, 2-41, 2-43, 2-105, 2-109
Ftg-Hyd E90 Jm04/Om04, 2-41, 2-43, 2-107, 2-117, 2-121, 2-131, 3-33
Ftg-Hyd E90 Jm04/Om06, 2-33, 2-35, 2-109, 2-111
Ftg-Hyd E90 Jm06/Jf06, 2-111
Ftg-Hyd E90 Jm06/Om06, 2-87, 3-33
Ftg-Hyd E90 Jm06/Om08, 2-33, 2-35, 2-79, 2-81, 2-109
Ftg-Hyd E90 Jm08/Jf08, 2-107, 2-109, 2-111, 3-35
Ftg-Hyd E90 Jm08/Jm08, 2-57, 2-59
Ftg-Hyd E90 Jm08/Om08, 2-107, 2-109, 3-35
Ftg-Hyd E90 Jm08/Om10, 2-131
Ftg-Hyd E90 Jm12/Jf12, 2-105
Ftg-Hyd E90 Jm12/Om12, 2-79, 2-81, 2-97
Ftg-Hyd E90 Jm12/Om16, 2-97
Ftg-Hyd E90 Jm20/Jf20, 2-97
Ftg-Hyd E90 Pm02/Jm04, 2-69
Ftg-Hyd E90 Pm02/Jm06, 2-69
Ftg-Hyd E90 Pm04/Jm06, 2-69
Ftg-Hyd E90 Pm06/Jm06, 2-69
Ftg-Hyd E90 Special Jm12/Jf12, 2-105
Ftg-Hyd E90, 2-105, 2-117
Ftg-Hyd Plg Om06, 2-33, 3-33
Ftg-Hyd Plg Om12, 2-105
Ftg-Hyd Rst JM04/.047, 2-111
Ftg-Hyd Rst Jm04/.063, 2-33, 2-35
Ftg-Hyd Str Jm12/Om16, 2-97
Ftg-Hyd Str Jm04/Jf06, 2-109
Ftg-Hyd Str Jm04/Om06, 2-109, 2-111
Ftg-Hyd Str Jm04/Om08, 2-33, 2-35
Ftg-Hyd Str Jm06/Jf08, 3-35
Ftg-Hyd Str Jm06/Om06, 2-107, 2-109, 2-133, 3-33, 3-35
Ftg-Hyd Str Jm06/Om08, 2-79, 2-81, 2-111
Ftg-Hyd Str Jm06/Om10, 2-97, 2-113
Ftg-Hyd Str Jm06Om06L, 2-107
Ftg-Hyd Str Jm08/Jm06, 2-113, 2-131
Ftg-Hyd Str Jm08/Jm08, 2-131
Ftg-Hyd Str Jm08/Om08, 2-107, 2-111, 2-119
Ftg-Hyd Str Jm08/Om10, 2-97, 2-131
Ftg-Hyd Str Jm08Om08L, 2-107
Ftg-Hyd Str Jm12/Om12, 2-27, 2-105
Ftg-Hyd Str Jm12/Om16, 2-87
Ftg-Hyd Str Jm12Om12L, 2-107
Ftg-Hyd Str Jm20/Om20, 2-97, 2-105
Ftg-Hyd Str Mom14/Jm08, 2-59
Ftg-Hyd Str Om/Of, 2-105
Ftg-Hyd Str Om08/Of06, 3-35
Ftg-Hyd Str Pm02/Jm06, 2-69
Ftg-Hyd Str Pm04/Jm06, 2-69
Ftg-Hyd Str, 2-119
Ftg-Hyd str, 2-117
Ftg-Hyd StrJm06/Om10, 3-35
Ftg-Hyd Tee Jm04Jfjm, 2-109, 2-111
Ftg-Hyd Tee Jm04Jmjf, 2-109, 2-111
Ftg-Hyd Tee Jm04Jmjm, 2-41, 2-43
Ftg-Hyd Tee Jm04Jmom, 2-105
Ftg-Hyd Tee Jm04Omjm, 2-79, 2-81
Ftg-Hyd Tee Jm06JmJf, 2-109
Ftg-Hyd Tee Jm06Jmjf, 2-105, 2-111
Ftg-Hyd Tee Jm06Jmom, 2-105
Ftg-Hyd Tee Jm06Omjm, 3-35
Ftg-Hyd Tee Jm08Jmjf, 2-107, 3-35
Ftg-Hyd Tee Jm08OmJm, 2-109
Ftg-Hyd Tee Jm08Omjm, 2-111
Ftg-Hyd Tee Jm12Jfjm, 2-97
Ftg-Hyd Tee Jm12Jmjf, 2-105
Ftg-Metric Str Omm14/Jm08, 2-57
Ftg-Plug Npt 04Pm Hx Soc, 2-69
Fuelline, .312 Od, 2-71
Fuelline, .312Od, 2-71

G

- Gage, Oil Level, 5-5
- Gas Cap, Protectoseal, 3-66
- Gas Spring, 2-115
- Gasket, 2.7D 1.5B.12T 5/ 2.1Bc, 2-69, 2-71
- Gasket, Air Cond Box, 3-51
- Gasket, Cover, Alum, 3-73
- Gasket, Cylinder Head, 5-3
- Gasket, Duct, 2-127
- Gasket, Exhaust Manifold, 5-13
- Gasket, Exhaust, 2-67
- Gasket, Fire Switch, 2-131
- Gasket, Gear Cover, 5-7
- Gasket, Head Cover, 5-3
- Gasket, Hyd Cap, 2-105
- Gasket, Hyd Tank Breather, 2-105
- Gasket, Injection Pump, 5-15
- Gasket, Intake Manifold, 5-12
- Gasket, Leak Pipe, 5-15
- Gasket, Oil Filter, 5-19
- Gasket, Oil Jet, 5-7
- Gasket, Oil Pan, 5-7
- Gasket, Oil Pipe, 5-19
- Gasket, Push On, 3-43
- Gasket, Rear Cover, 5-9
- Gasket, Suction Pipe, 5-19
- Gasket, Thermostat, 5-17
- Gasket, Timing Case, 5-7
- Gasket, Timing Cover, 5-7
- Gasket, Vac Fan, 2-129
- Gasket, Water Pump, 5-17
- Gasket–Water Pk, 2-73
- Gasket, 5-3, 5-15, 5-17, 5-21
- Gauge, Sight Lh, 2-105
- Gear Set, 5-21
- Gear, Cam, 5-11
- Gear, Crankshaft, 5-9
- Gear, Friction, 5-9, 5-11
- Gear, Idle, 5-11
- Gear, Injection Pump, 5-15
- Gear, Ring, 5-9
- Gear, 5-21
- Geroter,Ring In En, 4-5, 4-9, 4-13, 4-17
- Geroter,Ring Ot En, 4-5, 4-9, 4-13, 4-17
- Gerotor Set Cl, 4-25, 4-26
- Gerotor Set, 4-19, 4-20, 4-21, 4-22
- Glass, Rear, 3-43
- Glass, Sliding, Lh, 3-43
- Glass, Windshield, 3-43
- Grease, Lubriplt EMB 14.5OZ, 2-3
- Grip Vinyl .18 X .75 X 4.00, 2-57, 2-59, 3-21, 3-25
- Grip, Handle, Flat, 3-59, 3-61
- Grommet Rbr 0.25Id For .09Matl, 3-16, 3-41
- Grommet, Rbr, .50 ID, For .25 Matl, 2-7
- Grommet,Rbr,0.25Id,For .09Matl, 2-135
- Grommet,Rbr,0.38Id,For .06Matl, 3-3, 3-5, 3-7, 3-9
- Grommet,Rbr,0.38Id,For .19Matl, 3-11, 3-13
- Grommet,Rbr,0.50Id,For .25Matl, 2-9
- Grommet,Rbr,0.56Id,For .13Matl, 3-15, 3-16
- Grommet,Rbr,0.62Id,For .06Matl, 2-55, 3-73
- Grommet,Rbr,0.63Id,For .13Matl, 3-3, 3-5
- Grommet, 3-43
- Guard Kit, Overhead, 3-17
- Guard Replmt Kit Side Brush Lh, 3-35
- Guard Wldt, Hopper, 2-51
- Guard Wldt, Lights, Revl & Flsh, 3-3, 3-5, 3-7, 3-9
- Guard Wldt, Lights, Revl&Flsh, 3-11, 3-13
- Guard Wldt, Overhead, 3-17
- Guard Wldt, Side Brush, 2-113
- Guard Wldt, Sidebrush, 3-35
- Guard, Mirror, 3-49
- Guard, Side Brush Repl Kit Rh, 2-113
- Guard, Side Brush, 2-113, 3-35
- Guide, Valve, 5-3
- Guide, 2-53

H

- Handle Wldt, Center, 2-109
Handle Wldt, Latch, 2-19
Handle Wldt, Lh, 2-109
Handle Wldt, Rh, 2-109
Handle Wldt, Side Brush Lift, 3-31
Handle, Center, 2-111
Handle, Grab, 3-19, 3-23
Handle, Lh, 2-111
Handle, Lift, Brush, 2-133
Handle, Rh, 2-111
Handle, 2-57, 2-59, 2-115, 3-59, 3-61
Hanger, Engine, Front, 5-3
Hanger, Engine, 5-3
Harness, Rfs Jumper, 3-73
Harness, Air Conditioner, 3-53
Harness, Alarm, Backup, 3-15, 3-16
Harness, Hopper 800/810, 2-148
Harness, Hopper, Rfs, 3-73
Harness, Hopper, 2-148
Harness, Jumper, Backup, 3-15
Harness, Main, Die, 800, 2-148
Harness, Motor, Duct, 3-73
Harness, Neutral, Start, 3-71
Harness, Rev/Flash Light,Cab O, 3-11, 3-13
Harness, Side Brush, L.H., 3-36, 3-37
Harness, Tank, Fuel, 2-69, 2-71
Harness, Turn/Rotate/Tail Lights, 2-148
Harness, Wire, 3-43
Harness,Rev/Flsh Light,Cab,Ohg, 3-3, 3-5, 3-7, 3-9
Head, Cylinder, 5-3
Head, Oil Filter, 5-19
Headlight Assy,210G, 3-15, 3-16
Headlight, 12V.Rect., 2-45, 2-47
Headliner, Front, 3-47
Headliner, Rear Cw, 3-47
Heater Hose 72In De, 4-45, 4-47, 4-49, 4-51
Heater, Pressurizer (Repl. by 21271), 4-49
Heater, Pressurizer Group (See Breakdowns), 3-55
Heater, Pressurizer Grp (Repl. By 21271) (See Breakdowns), 3-55
Heater, Pressurizer, 4-51
Heater/Pressurizer Assy, 3-55
Hinge Wldt, W/Pin, 2-23
Hinge Wldt, 2-23, 2-45
Hinge, W/Pin, 2-25
Hinge, 2-19, 2-21, 2-25, 2-47
Holder, Brush, 5-21
Holder, Nozzle, 5-15
Holder, Oil Gage, 5-5
Hook, 2-79
Hopper Floor Kit, St Stl 800, 3-26
Hopper Wldt , 2-37
Hopper Wldt, 2-39
Horn, 12V, 2-19, 2-21
Horn, Back-Up Alarm, 3-15, 3-16
Hose Clamp De, 4-45, 4-47, 4-49, 4-51
Hose Elbow 5/8 De, 4-45, 4-47, 4-49, 4-51
Hose Radiator,1.50 Idx 3.0 Lg, 2-73
Hose, A/C #10, 3-53
Hose, A/C #8 134A, 3-53
Hose, A/C Drain, 4-45, 4-47
Hose, Breather, 5-3
Hose, Fan Inlet, 2-127, 2-129
Hose, Fuel Line .31 Idx11.0, 2-71
Hose, Fuel Return, 5-15
Hose, Hyd, Special, 2-71
Hose, Molded, Air Intake, 2-65
Hose, Molded, Se, Diesel, 3-65
Hose, Rad, Upper, 2-73
Hose, Radiator, Lower, 2-73
Hose, Reducer, 3-19
Hose, Rubber.38Idx.62Od 21.0Lg, 3-65
Hose, Rubber, Elbow, 3.00, 3-23
Hose, Rubber, Elbow, 3-51
Hose, Rubber, 3-19, 3-23
Hose, Vac, Rubber, 2-55
Hose, Vacuum, .16 Id X 76.0 Lg, 3-73
Hose& Cuff Assy,Vinyl3.0Idx 24, 3-19, 3-23
Hose& Cuff Assy, 3-23
Hose&2Cuff Assy,Vinyl2.0Id10Ft, 3-59, 3-61
Hose-Hyd Ar 04 , 2-103
Hose-Hyd Ar 04, 2-103

Hose-Hyd Ar04, 2-103
 Hose-Hyd Low 04 Jf/J9, 2-101
 Hose-Hyd Low 04, 2-103
 Hose-Hyd Low04 Jf/J9, 2-69, 2-101, 2-103
 Hose-Hyd Low06 Jf/J4, 2-69
 Hose-Hyd Low06 Jf/J9, 2-69, 2-101
 Hose-Hyd Low06 Jf/Jf, 2-69
 Hose-Hyd Low06, 2-103
 Hose-Hyd Low08 Jf/J9, 2-57
 Hose-Hyd Low08 See60108 Jf/J9, 2-59
 Hose-Hyd Low12 Jf/Jf, 2-101, 2-103
 Hose-Hyd Low12, 2-103
 Hose-Hyd Med 04, 3-39
 Hose-Hyd Med 06, 3-39
 Hose-Hyd Med04 Jf/J4, 2-101, 2-103
 Hose-Hyd Med04 Jf/J9, 2-101
 Hose-Hyd Med04 Jf/Jf, 2-101, 2-103
 Hose-Hyd Med04 Jf/JI9, 2-101
 Hose-Hyd Med04, 2-103
 Hose-Hyd Med06 Jf/J4, 2-101
 Hose-Hyd Med06 Jf/J9, 2-101, 2-103, 3-38
 Hose-Hyd Med06 Jf/Jf, 2-101, 2-103
 Hose-Hyd Med06, 2-103
 Hose-Hyd Med08 Jf/J4, 2-101, 2-103
 Hose-Hyd Med08 Jf/J9, 2-101, 2-103
 Hose-Hyd Med08 Jf/Jf, 2-101
 Hose-Hyd Med08, 2-103
 Hose-Hyd Med12 Jf/J4, 2-101
 Hose-Hyd Med12, 2-103
 Hose-Hyd Med78 Jf/J9, 2-103
 Hose-Hyd Replm Kit 800/810, 2-101
 Hose-Hyd Replmt Kit 800/810, 2-101
 Hose-Hyd Suc20 Jf/J4, 2-101
 Hose-Hyd Suc20 Spcl 22.5, 2-103
 Hose-Hyd, 2-103
 Housing Assembly, Water Pump, 5-17
 Housing Assy, Rear Hub, 2-87
 Housing Assy, 4-19
 Housing En, 4-7, 4-15
 Housing S/A En, 4-3, 4-7, 4-11, 4-15
 Housing Wldt, Vac Fan, Front, 2-127, 2-129, 3-21

Housing Wldt, Vac Fan, Rear, 2-127, 2-129
 Housing, Brg, 4-19
 Housing, Flywheel, 5-7
 Housing, Sppt, Wheel, 2-87
 Housing,Control En, 4-39
 Housing,Control, 4-41
 Housing, 4-21, 4-22
 Hub and Stud Assy., 2-87
 Hub Assy, 2-91

I

Impeller 9.5 Dia. 18 Blade Mac, 2-127, 2-129
 Indicator Service Air Filter, 2-65, 3-65
 IndicatorLight, Glow Plug, 2-135
 Insert, 5-3
 Instr. Valve Repair Info, 4-37
 Insulation, Acoustic, Fan, 2-127, 2-129, 3-21
 Insulation, Acoustic, Vac Fan, 2-127, 2-131
 Insulation, Acoustic,Vac Fan, 2-127
 Insulation, S/Foam 1.0X3.0X3.0, 2-9
 Insulation, S/Foam 1.5X4.0X4.0, 2-9
 Insulation, S/Foam, Seat, 2-17
 Insulation, S/Foam, 2-9, 2-19, 2-21, 2-25, 3-25
 Insulation,S/Foam .8X19.3X20.3, 3-65
 Insulation,S/Foam1.0X 3.0X 3.0, 2-7
 Insulation,S/Foam1.5X 4.0X 4.0, 2-7
 Isolator, Exhaust, 2-67
 Isolator, Mounting, 2-59
 Isolator, Mtg, 2-57
 Isolator, Vac Fan, 2-107
 Isolator, Vibration, 2-131
 Isolator-Vibration .25-20, 2-67
 Isolator-Vibration .31-18, 2-27
 Isolator-Vibration,60 Lb.Ratng, 2-131
 Isolator, 2-57, 2-59

J

Jamb Nut 7/16 Hex De, 4-45, 4-47, 4-49, 4-51
 Jet, Oil, 5-7

K

Key En, 4-5, 4-9, 4-13, 4-17
Key Set, Switch Ku, 2-135
Key Set, 3-45
Key, Square 0.12 0.12 00.50 LG, 4-24
Key, Woodruff, 4-20, 5-9, 5-11, 5-15
Key, 4-19, 4-23
Knob, Adjusting, 2-115, 3-31
Knob, Fan, 4-45, 4-47, 4-49, 4-51
Knob, Handle, Threaded, 2-115, 3-31
Knob, Plastic, 2-117, 2-123, 2-125
Knob, Temp, 4-45, 4-47
Knob, 0.38–16, 1.25 Dia, Plastic, 3-61
Knob, 2-109, 2-111

L

Label Set, Info & Hazard, 2-149
Label Set, Operational 800, 2-149
Label, Numerals 800, 2-149
Label, Vac Wand, 3-59, 3-61
Lanyard Assy., 2-27
Latch, Bolt, 2-23, 2-25, 3-65
Latch, Bumper, 2-49, 2-51
Latch, Door, 3-70
Latch, Hook (Supplier's Lh), 2-13
Latch, Hook (Supplier's Rh), 2-11, 2-23
Latch, Hook Rh, 2-25
Latch, Hook, Lh, 3-65
Latch, Hook, Rh, Single Catch, 2-47
Latch, Hook, Rh, 2-45
Latch, Rear Wind, 3-43
Latch, 2-19, 2-21, 2-27, 2-119
Leg Wldt, Bumper, Se, 3-27, 3-28, 3-29
Lens, Flashing Lite Fr207 Amber, 3-3, 3-7, 3-11
Lens, Flashing Lite Fr207 Blue, 3-3, 3-7, 3-11
Lens, Flashing Lite Fr207 Red, 3-3, 3-7, 3-11
Lens, Rev. Light, Amber, 3-5, 3-9, 3-13
Lens, Rev. Light, Blue, 3-5, 3-9, 3-13
Lens, Rev. Light, Red, 3-5, 3-9, 3-13
Lever Carburator, 3-25
Lever Wldt, 2-115, 3-31
Lever, Blower, 3-21

Lever, Brake, 2-93
Lever, Handle, Latch, 2-21
Lever, 2-115, 3-25, 3-31, 5-21
Light Assy Stop/Red 12V– . A, 2-9
Light Assy Stop/Red 12V– A, 2-7
Light Kit Flashing, 3-11
Light Kit Flsh 800L Cab, 3-7
Light Kit Flsh 800L Ohg, 3-3
Light Kit Revl 800 Low, 3-13
Light Kit Revl 800L Cab, 3-9
Light Kit Revl 800L Ohg, 3-5
Light Kit, Side Brush, 3-41
Light, Dome 12V, 3-43
Light, Flashing, Amber, 12V–Re, 3-3, 3-7, 3-11
Light, Spot Hi–D 255li L, 3-41
Light, Rev. Amber 12V–Reworked, 3-5, 3-9
Light, Rev. Amber 12V, 3-13
Liner, Cylinder, 5-5
Link, Connecting, 3-45
Link, Eccentric, 2-53
Link, Feedback En, 4-39
Link, Feedback, 4-41
Link, Pivot, Machined, 2-29
Link, Pivot, 2-31
Lintel Wldt, Main, 2-19
Lintel Wldt, Rear, 2-19
Lintel, Main, 2-21
Lintel, Rear, 2-21
Lockwasher En, 4-3, 4-7, 4-11, 4-15
Louver, Recirc, 4-47, 4-51
Louver, 4-45, 4-47, 4-49, 4-51

M

Magnet, Drive Brush, 2-47
Magnet, 2-41
Maintenance Kit, 400HR 800/810 Diesel, 2-3
Maintenance Kit, 800HR 800/810, 2-3
Maintenance Kit, Skirts 800, 2-3
Maintenance Kit, Skirts, 2-3
Manifold, Exhaust, 5-13
Manifold, Intake, 5-12
Manual Op/Mt 800D French, 3-74

Manual Op/Mt 800D Spanish, 3-74
 Manual Control En, 4-39
 Manual Pkg 800D, 3-74
 Manual, Service 800/810, 3-74
 Manual–Fiche Pkg 800D, 3-74
 Metal Set, Connecting Rod OS 0.254, 5-9
 Metal Set, Connecting Rod OS 0.508, 5-9
 Metal Set, Connecting Rod OS 0.762, 5-9
 Metal Set, Connecting Rod, 5-9
 Metal Set, Main Bearing OS 0.254, 5-9
 Metal Set, Main Bearing OS 0.508, 5-9
 Metal Set, Main Bearing OS 0.762, 5-9
 Metal Set, Main Bearing, 5-9
 Metal Set, Thrust OS, 5-9
 Metal Set, Thrust, 5-9
 Mirror Kit, Side Brush, 3-49
 Mirror, Side Brush, 3-49
 Mirror, 8.0 Round, Convex, 3-49
 Molding, Trim 11–14Ga 3.00, 3-11, 3-13, 3-15, 3-16
 Molding, Trim 11–14Ga 4.0, 2-93
 Molding, Trim 11–14Ga 5.00, 2-15
 Molding, Trim 11–14Ga 15.75, 2-15
 Molding, Trim 11–14Ga 15.75, 2-17
 Molding, Trim 11–14Ga 5.75, 2-17
 Molding, Trim 16Ga&Thinr 10.0, 2-17
 Molding, Trim 3/16–5/16 2.75, 2-115
 Motor, Ele, Geared, 12Vdc, 3-73
 Motor, Electric, 13.6 Vdc, 2-53
 Motor, Hyd (Repl. By 79781) (See Breakdowns), 3-35
 Motor, Hyd Gear In 17.9 B 1500 (See Breakdowns), 3-35
 Motor, Hyd, (Repl. by 79781) (See Breakdowns), 2-113
 Motor, Hyd, (See Breakdowns), 2-113
 Motor, Hydraulic (Repl. by 79781), 4-21
 Motor, Hydraulic, 4-20, 4-22, 4-23, 4-24
 Motor, Propelling, 4-19
 Motor, Wiper 12V, 3-43
 Motor–Hyd Gear Ex (See Breakdowns), 2-131
 Motor–Hyd Gear In (See Breakdowns), 2-87
 Motor–Hyd Gear In (See Breakdowns), 2-79, 2-119

Motor–Hyd, Gear In 10.0 (See Breakdowns), 2-81
 Muffler, Exhaust, 2-67

N

Nut En, 4-3, 4-7, 4-11, 4-15
 Nut Low Crown .62–18, 2-117
 Nut, Cart., LNG CP, 4-31, 4-33, 4-35
 Nut, Cart., LNG., 4-28
 Nut, Cart., SHT CP, 4-31, 4-33, 4-35
 Nut, Cart., Sht, 4-29
 Nut, Connecting Rod, 5-9
 Nut, Flange, 5-22
 Nut, Jam, 4-3, 4-7, 4-11, 4-15
 Nut, Slotted Hex, 4-20
 Nut, Wheel Lug, 9/16–18, 2-89
 Nut, Wheel Lug, 2-87
 Nut, Lock–Special 2.16–18Uns, 2-87
 Nut, Wing .44–20 Special, 3-65
 Nut–Hxslot 1.00–20 Pltd, 2-89
 Nut–Low Crown .31–18 Pltd, 3-55
 Nut–Low Crown .31–18 Pltd, 3-53
 Nut–Low Crown .50–20 Pltd, 2-127
 Nut–Low Crown .50–20 Pltd, 2-129
 Nut–Wheel .50–20, 2-89
 Nut, 4-19, 5-7, 5-11, 5-12, 5-13, 5-15, 5-19

O

O–Ring #6, 3-53
 O–Ring Gland, 2-97
 O–Ring, #8, 3-53
 O–Ring, 3-53, 5-3, 5-19
 Oper/Video Vhs, 800, 3-74
 Orifice, Valve En, 4-3, 4-7, 4-11, 4-15
 Output Shaft Assembly, 4-20

P

Pad, Rubber, 3-19, 3-23
 Pad, Tread, 2-95
 Pad, 2-93, 3-25
 Paddle Handle, 3-45
 Pan, Oil, 5-7
 Panel Wldt W/Label, 2-17

CROSS REFERENCE

Panel Wldt, Cover, 3-65	Pin Weldt., 2-31
Panel Wldt, Duct, Vac Fan, 2-127	Pin Wldt., 2-35
Panel Wldt, Fender, Lh, 2-45, 2-47	Pin Wldt, 1.250 Od X 4.50, 2-29, 2-33
Panel Wldt, Fender, Rh, 2-45, 2-47	Pin Wldt, 1.500 Odx 5.00, 2-29
Panel Wldt, Headlight, 2-45	Pin Wldt, Latch, 2-45, 2-47
Panel Wldt, Hopper, Floor, LH, 3-26	Pin, 1.00 Odx 4.50, Drilled, 2-33, 2-35
Panel Wldt, Hopper, Floor, RH, 3-26	Pin, 1.25 Odx 3.50, Grooved, 2-33, 2-35
Panel Wldt, Oper Comp, 2-15	Pin, 1.25 Odx 5.00, Drilled, 2-29
Panel Wldt, Rear, Lh, 2-9	Pin, 1.250 Od X 4.50, 2-31, 2-35
Panel Wldt, Rear, Rh, 2-9	Pin, 1.500 ODx7.81, Drilled, 2-31
Panel Wldt, Shaker, 2-53	Pin, 1.500 Odx 5.00, 2-31
Panel Wldt, Support, Seat, 2-15	Pin, 1.500 Odx6.50, Drilled, 2-29
Panel Wldt, Transition, Fan, 2-79	Pin, Clevis .18 Dia.X .62 Lg, 2-111
Panel Wldt, 2-37	Pin, Clevis .25 Dia, 1.000 Lg., 2-95
Panel, Access, 2-95	Pin, Clevis .31 Dia X 4.50 Lg, 2-95
Panel, Air Conditioning, 2-15, 2-17	Pin, Clevis .375D X 1.000 Lg, 2-93
Panel, Bottom, Hopper, Rh, 2-39	Pin, Clevis .375D X 1.312 Lg, 2-95
Panel, Cover, A/C Filter, 3-65	Pin, Clevis .50 Dia X 2.25 Lg, 2-41, 2-43
Panel, Cover, Access, 2-15, 2-17	Pin, Clevis .50 Dia X 4.50 Lg, 2-95
Panel, Cover, Dash, 2-135	Pin, Cntrl Assy En, 4-39
Panel, Cover, Front A/C, 3-65	Pin, Cotter .094X1.00, 2-117
Panel, Cover, Rear, A/C Filter, 3-65	Pin, Headed En, 4-39
Panel, Cover, 3-59, 3-61	Pin, Headed, 4-41
Panel, Deflector, Dirt, Lh, 2-37, 2-39	Pin, Knock, 5-9
Panel, Deflector, Dirt, Rh, 2-37, 2-39	Pin, Spring Cl, 4-25
Panel, Flap Valve, 3-25	Pin, Top Indicator, 5-7
Panel, Fuel Inlet, 2-15, 2-17	Pin, Tubular, 5-5
Panel, Headlight, 2-47	Pin,Clevis,0.25 Dia.X 0.50 Lg, 2-57
Panel, Hopper Door, 2-41	Pin,Clevis,0.25 Dia.X 0.75 Lg, 2-59, 2-95, 2-109, 3-25
Panel, Hopper, Bottom, Lh, 2-39	Pin,Clevis,0.31 Dia X 1.00 Lg, 2-115, 3-31
Panel, Lintel, 3-23	Pin,Clevis,0.37 Dia.X 2.12 Lg, 2-117, 3-33
Panel, Permafilter, Upper, 2-37, 2-39	Pin,Clevis,0.50 Dia.X 2.00 Lg, 2-121
Panel, Support, Seat, 2-17	Pin,Clevis,0.50 Dia.X 3.50 Lg, 2-109, 2-111
Panel, Transition, Fan, 2-81	Pin,Clevis,1.00 Dia.X 2.50 Lg, 2-35
Panel, Vac Duct, 3-25	Pin,Hair Cotter #Lhcot-2,Leitk, 2-113, 3-35
Panel, 2-25, 3-3, 3-5, 3-7, 3-9	Pin,Roll,.18Odx1.62L,.187/.192, 3-59, 3-61
Pedal Wldt, Lower, 2-95	Pin- Cotter .094X0.75, 3-65
Pedal Wldt, 2-93	Pin, 2-31, 2-41, 2-43, 2-113, 3-35, 4-26, 5-3, 5-7, 5-9
Pedal, Upper, 2-95	Pinion, 5-21
Pin Assy, .312X3.0 W/Lanyard, 2-113, 3-35	Pipe, Exhaust, Diesel, 2-67
Pin Assy, Spring, 3-45	Pipe, Fuel Injection No.1, 5-15
Pin Hair Cotter .056Dx1.1L, 3-25	

Pipe, Fuel Injection No.3, 5-15
Pipe, Fuel Injection, 5-15
Pipe, Fuel Leak, 5-15
Pipe, Fuel Pump Feed, 5-15
Pipe, Fuel, 5-15
Pipe, Oil Gage, 5-5
Pipe, Oil, 5-19
Pipe, Seal, 5-5
Piston Set, 5-9
Piston, Servo, 4-7, 4-15
Pivot Wldt, Wheel, 2-87
Plate Wldt, Adj, Brush, 2-123
Plate Wldt, Angle, 2-117
Plate Wldt, Compressor, 3-53
Plate Wldt, Cover, 2-115, 3-31
Plate Wldt, Link, Lh, 2-49
Plate Wldt, Link, Rh, 2-49
Plate Wldt, Mtg, Die, 2-57
Plate Wldt, Skirt, 3-63
Plate Wldt, Vac Door, 3-59, 3-61
Plate Wldt, 2-117, 3-33
Plate, Adj, Brush, 2-125
Plate, Angle, 2-113, 2-115, 2-117, 3-33, 3-35
Plate, Backing, Handle, 3-19, 3-23
Plate, Backing, 2-75, 2-77
Plate, Baffle, 5-3, 5-9
Plate, Circuit Breaker, 2-137
Plate, Cover En, 4-3, 4-7, 4-11, 4-15
Plate, Cover, 2-39, 2-117
Plate, Damper, Inlet, 3-21
Plate, Damper, Outlet, 3-21
Plate, Dust Seal, 5-17
Plate, Guide, Bumper, 2-7, 2-9
Plate, Latch, 3-61
Plate, Lever, 3-21
Plate, Link, 2-31
Plate, Mounting Die, 2-59
Plate, Mounting, Pump,, 2-59
Plate, Mounting, Rfs Control, 3-73
Plate, Mounting, Tank, Gas, 2-71
Plate, Mounting, Vac Door, 3-59, 3-61
Plate, Mtg, Check Valve, 3-35
Plate, Mtg, Latch, 2-119
Plate, Mtg, Pump, Machining, 2-57
Plate, Mtg, Relay, 2-137
Plate, Mtg, Steering Boot, 2-133
Plate, Mtg, Tank, Gas, 2-69
Plate, Mtg, Valve, Solenoid, 2-107
Plate, Oil Baffle, 5-3
Plate, Pin Retainer, 2-31, 2-35
Plate, Pivot, Wheel, 2-87
Plate, Retainer, Foam, 2-131
Plate, Retainer, 3-63
Plate, Seal, 2-119
Plate, Shim, Bumper, .06 Thk, 2-49
Plate, Shim, Hopper, 2-49
Plate, Shutter, 3-73
Plate, Side Brush Roller, 2-117
Plate, Side Brush, Roller, 3-33
Plate, Spacer, 2-35
Plate, Spring – Side Brush, 2-75, 2-77, 2-127, 2-129
Plate, Striker, 2-27
Plate, Support, Cover Se, 3-65
Plate, Tapped, 2-123
Plate, Thrust, 5-11
Plate, Vac Fan, 2-129
Plate, Wear, 4-26
Plate–Cover, 2-117
Plate, 2-83, 2-95, 2-117, 3-11, 3-13, 3-33, 3-45, 3-59, 3-61, 3-63, 3-65, 4-19
Plug & O–Ring En, 4-37
Plug #2, 4-31, 4-33, 4-35
Plug #8, 4-3, 4-7, 4-11, 4-15
Plug Assembly En, 4-37
Plug Assembly, 4-19
Plug Assy,Byd En, 4-37
Plug En, 4-5, 4-9, 4-13, 4-17, 4-39
Plug Gage #4, 4-31, 4-33, 4-35
Plug Gage #6, 4-31, 4-33, 4-35, 4-37
Plug S/A En, 4-3, 4-7, 4-11, 4-15
Plug Weld, Brush Drive, Sweep, 2-119
Plug Wldt, Idler, 2-119
Plug, #2 O–Ring, 4-29
Plug, Blind, 5-5

CROSS REFERENCE

Plug, Camshaft, 5-5
Plug, Drain, 3-59, 3-61, 5-7
Plug, Glow, 5-22
Plug, Rocker Arm, 5-11
Plug, Thermostat Case, 5-3
Plug, Tube, 2-119
Plug,#12 O-Ring Ph, 4-3, 4-7, 4-11, 4-15
Plug, 4-25, 4-41, 5-3, 5-5, 5-13, 5-19, 5-22
Plugbtn .62H .03-.12 Blacknyl, 2-137
Plunger En, 4-37
Plunger, Control, 5-19
Poppet En, 4-5, 4-9, 4-13, 4-17, 4-37
Poppet, 4-25
Pulley – Cable, 1.5 Dia, 2-115, 3-31, 3-33
Pulley Assy, Cable, 1.5 Dia, 2-117
Pulley, Crankshaft, 5-9
Pulley, 5-9
Pump, Fuel, Ele, 2-69, 2-71
Pump, Fuel, 2-71
Pump, Gear, 4-18
Pump, Hyd Piston V 2.48 (see breakdowns), 3-71
Pump, Hyd Piston V 2.48 R4500, 4-7, 4-9, 4-15, 4-17
Pump, Injection, 5-15
Pump, Oil, 5-19
Pump-Hyd Gear Ex (See Breakdowns), 2-97
Pump-Hyd Piston V (see Breakdowns), 2-97
Pump-Hyd Piston V 2.48 R4500, 4-3, 4-5, 4-11, 4-13

R

Race, Bearing Ce, 4-3, 4-7, 4-11, 4-15
Race, Bearing, 4-25, 4-26
Race, Thrust, 4-20, 4-21, 4-22
Radiator, 4 Row, 6 Fin, 2-77
Radiator, 2-75
Rear Glass Asy-Cab, 3-43
Rear Glass Asy-Door, 3-45
Relay, Glow Plug, 5-22
Relay, Shrouded, 12 Vdc, 2-137, 3-11, 3-13, 3-73
Relay, Shrouded, 12V, 3-3, 3-5, 3-7, 3-9
Relief Cart., 4-36
Relief Valve Sa En, 4-5, 4-9, 4-13, 4-17
Repair Info, Motor, 4-21, 4-22
Repair Info,Cyl En, 4-43
Repair Info,Pmp En, 4-5, 4-9, 4-13, 4-17
Repair Info,Scu Cl, 4-26
Replacement Kit, Bumper, Die, 2-9
Replm Kit, Case, 2-135
Replm Kit, Cir Board, 2-135
Replm Kit, Hourmeter, 2-135
Replm Kit, Instr Panel , 2-135
Replm Kit, Lamp, Backlighting (Set of 8), 2-135
Replm Kit, Lamp, Fault (Set of 8), 2-135
Replm Kit, Seal, 2-135
Replm Kit, Sun Shield, 2-135
Replm Kit, Touch Panel , 2-135
Retainer Replacement Kit, 2-117
Retainer, Frt, 4-19
Retaining Ring-External, 1.25D, 2-33, 2-35
Retaining Rng En, 4-37
Rfs Kit, 3-73
Ring Set, Piston, 5-9
Ring Wldt, Mtg, Filter, 2-53
Ring Wldt, Shaker, 2-53
Ring, Isolator, Outer Rbr, 2-77, 2-129
Ring, Isolator, Outer, Rbr, 2-53, 2-75, 2-127
Ring, Rear Window, 3-43
Ring, Retainer, Lock, 2-87
Ring, Retainer, 4-25, 4-26
Ring, Retaining En, 4-5, 4-9, 4-13, 4-17, 4-39
Ring, Retaining, Ex 1.5 Dia Hd, 2-29, 2-31
Ring, Retaining, Ext 1.12, 2-53
Ring, Retaining, 4-41, 5-9, 5-11, 5-17
Ring, Rubber, 5-21
Ring,Retain,Ex,0.50 Stl Steel, 2-95
Ring,Retain,Ex,0.50Od,Heavy Dt, 2-133
Ring, 2-109, 2-111
Rivet, Plastic .250X.898, 3-65
Rivet, Plastic .325D X .787, 2-17
Rivet, Plastic, 2-11, 2-13
Rod Support, Cover, 3-65
Rod Wldt, Adjustment, 2-93
Rod Wldt, Brush Pressure, 2-123
Rod Wldt, Push, Brake, 2-93

Rod Wldt, Seat, 2-15
 Rod, Cam Adjuster, 2-115, 3-31
 Rod, Connecting, 5-9
 Rod, Inlet, 3-21
 Rod, Latch, Steering, Tilt, 2-133
 Rod, Push, 3-25, 5-11
 Rod, Seat, 2-17, 3-65
 Rod, Thread, 2-117, 2-125
 Rod, Threaded .50–13, 2-121
 Rod–Thrd, 1End M06X1.0 X 6.40, 2-19
 Rod–Thread, 2End M08X1.25X10Lg, 2-93
 Rod–Thread, Full M10X1.5 X1.50, 2-115, 3-31
 Roll Pin En, 4-5, 4-9, 4-13, 4-17
 Rotating Kit, 4-3, 4-7, 4-11, 4-15

S

Scr Set .31–18X0.50, 3-31
 Scr Set M 6X1.0 20 , 2-109
 Scr Soc .38–16X0.75 , 2-133
 Scr–Hex .38–16X5.00 G5 Pltd, 2-61
 Scr–Set 10–24X0.25 Nylon Loc, 3-73
 Scr–Shld .500Dx0.50L .38–16, 2-7
 Screen, Filter, 2-53
 Screen, Guard, Lower, 2-81
 Screen, Guard, 2-79, 2-81
 Screw Set M 6X1.020, 2-111
 Screw Set, 5-21
 Screw, Bleeder, 5-16
 Screw, Cap En, 4-7, 4-9, 4-15, 4-17
 Screw, Cap En, 4-3, 4-5, 4-11, 4-13
 Screw, Cap, 4-3, 4-7, 4-11, 4-15, 4-19
 Screw, Set En, 4-39
 Screw, Set, 2-119, 4-41
 Screw, Tappet Adjusting, 5-11
 Screw–Hex M10X1.5 90 Full Thd, 2-113
 Screw–Hex M10X1.5, 2-113
 Screw–Set M10 X 1.50 2045H, 2-95
 Screw, 4-21, 4-22
 Seal Cw, 3-43
 Seal Kit, 4-20, 4-21, 4-22
 Seal Foam Rbr .75 1.5W 2.1L, 2-9
 Seal Kit, COil CP, 4-31, 4-33

Seal Kit, Cab, 3-43
 Seal Kit, Cart CP, 4-31, 4-33, 4-35
 Seal Kit, Cart., 4-28
 Seal Kit, Cart, 4-29
 Seal Kit, Coil CP, 4-35
 Seal Kit, Coil, 4-28, 4-29
 Seal Kit, Cyl, 4-43
 Seal Kit, Hyd Mtr Gear, 4-24
 Seal Kit, Motor, 4-19
 Seal Kit, One Cart, 4-27
 Seal Kit, Pump En, 4-7, 4-9, 4-15, 4-17
 Seal Kit, Pump En, 4-3, 4-5, 4-11, 4-13
 Seal Kit, Scu, 4-26
 Seal Kit, Shaft, 4-19
 Seal Kit, Shaker Panel, 2-53
 Seal Kit, Vlv En, 4-37
 Seal Kit,Cntrl En, 4-39
 Seal Kit,Cntrl, 4-41
 Seal Kit,Stg, 4-25
 Seal Kit, 4-18, 4-23, 4-36, 4-42
 Seal, 27.25L, 2-15
 Seal, 24.5 Lg, 2-15
 Seal, 48.0 Lg., 2-15, 2-17, 2-25
 Seal, 66.0 Lg, 2-15
 Seal, 7.00 Lg, 2-15, 2-17
 Seal, Bearing, 2-133
 Seal, Boot, Steering Column, 2-133
 Seal, Brush Comp, Side , 2-13
 Seal, Brush Comp, Side, 2-3, 2-11
 Seal, Brush Door, 2-11, 2-13
 Seal, Bulb, Sd–0504 19.75Lg, 3-65
 Seal, Bulb, Sd–0504 24.50Lg, 2-17
 Seal, Bulb, Sd–0504 28.00 Lg, 2-17
 Seal, Door, Brush, Lh, 2-11
 Seal, Door, Brush, Rh, 2-13
 Seal, Duct, 2-75, 2-77
 Seal, Dust, 2-37, 2-39, 2-53, 2-95
 Seal, Fan, Vac Outlet, 2-77
 Seal, Foam Rbr .19 .75W 8.43L, 3-59, 3-61
 Seal, Foam Rbr .75 1.5W 2.1L, 2-7
 Seal, Foam Rbr, .19 .75W 47.1L, 3-59, 3-61
 Seal, Foam, Urethane Covered, 2-39

CROSS REFERENCE

Seal, Foam, 2-7, 2-119
Seal, Handle, Valve, 2-135
Seal, Main Brush, 2-7
Seal, O-Ring .787Idx.210Th, 3-73
Seal, Oil, 5-7, 5-9
Seal, Pan, Top, 2-3, 2-7, 2-9
Seal, Rod, Adjuster, 2-17, 2-125
Seal, Rod, Brush Pressure, 2-123
Seal, Rubber, Propel Pedal, 2-95
Seal, Throttle Handle, Die, 2-59
Seal, Urethane Covered Foam, 2-47
Seal, Urethane, 2-41, 2-45, 3-73
Seal, Valve, 5-11
Seal, Water Pump, 5-17
Seal, Foam Rbr, .31 .75W 14.8L, 2-15
Seal, Foam Rbr, .31 .75W 14.8L, 2-17
Seal, Foam Rbr, .62 .62W 24.5L, 2-23
Seal, Foam Rbr, .62 .62W 24.5L, 2-19, 2-21, 2-25
Seal, 2-9, 2-17, 3-61, 3-73, 5-22
Seat Belt Kit, 3-70
Seat, Suspension, 2-15, 2-17
Seat, Valve Spring Lower, 5-11
Seat, Valve Spring Upper, 5-11
Seat, 4-25
Send Unit, Temperature, Water, 2-57
Send Unit, 2-69, 2-71
Sender, Filter, Hydraulic, 2-81, 3-57
Sending Unit, Water Temperature, 2-59
Sensor, Temperature, 5-23
Servo Piston Sa En, 4-3, 4-11
Set Screw, 2-53
Shaft and Brg, 4-19
Shaft Wldt, Main Brush, 2-119
Shaft Wldt, 3-59
Shaft, Clutch, 5-21
Shaft, Drive Sp En, 4-3, 4-7, 4-11, 4-15
Shaft, Eccentric, 2-53
Shaft, Idler, 2-119
Shaft, Input En, 4-39
Shaft, Input, 4-41
Shaft, Pivot, 2-113, 3-35, 3-73
Shaft, Rocker Arm, 5-11
Shaft, Water Pump, 5-17
Shaft, 3-61, 4-21, 4-22, 5-21
Shaker Bar Replacement Kit, 2-53
Sheave, Alternator, Die, 2-61
Sheave, Alternator, Se, 3-57
Sheave, Machining, 3-53
Shield, Dust, 2-7, 2-9
Shim .003Th 0.88Odx0.506ld, 2-129
Shim .005Th 0.88Odx0.506ld, 2-129
Shim .010 Thk En, 4-37
Shim .010Th 0.88Odx0.506ld, 2-129
Shim .015 Thk En, 4-37
Shim .020Th 0.88Odx0.506ld, 2-129
Shim .035 Thk En, 4-37
Shim .060Th 0.880Dxo.506ld, 2-129
Shim Vac Fanassy, 2-129
Shim..005Th 0.88Odx0.506ld, 2-127
Shim, Door Striker, 3-45
Shim, Vac Fan Assy, 2-127
Shim,.003Th 0.88Odx0.506ld, 2-127
Shim,.010Th 0.88Odx0.506ld, 2-127
Shim,.020Th 0.88Odx0.506ld, 2-127
Shim,.060Th 0.880Dxo.506ld, 2-127
Shim, 2-33, 2-51
Shims En, 4-5, 4-9, 4-13, 4-17
Shortblock, 5-5
Shoulder Screw, 2-53
Side Brush Lever Adjustmt Kit, 2-115
Skirt, Air Cleaner, Se, 3-65
Skirt, Brush Door, 2-3, 2-11, 2-13
Skirt, Cover, Sbdc, 3-63
Skirt, Deflection, 3-63
Skirt, Deflector, 2-37, 2-39
Skirt, Front, Indoor, 2-3, 2-11, 2-13
Skirt, Lip, 2-37, 2-39
Skirt, Retainer, 3-63
Skirt, Seal, Main Brush, 2-3, 2-7, 2-9
Skirt, 3-63
Sleeve .438B 1.00D .35Stl, 3-33
Sleeve, .259B .38D .62 Dom, 2-109
Sleeve, .259B .38D .62 Dom, 2-111
Sleeve, .320B .32D .49 Lc Stl, 2-45

Sleeve, .320B .32D .49 Lc Stl, 2-47
 Sleeve, .344B .50D .81 Cr.Anc, 2-93
 Sleeve, .370B .50D .38 Cd.Znc, 2-49
 Sleeve, .375B .62D1.06 Stl, 2-87
 Sleeve, .375B .75D .75 Stl, 2-115, 3-31
 Sleeve, .375B .75D .32 Stl, 2-115, 2-117, 3-31, 3-33
 Sleeve, .380B .62D .50 Smls, 2-93
 Sleeve, .380B .62D .66 Smls, 2-93
 Sleeve, .385B .62D .62 Cd.Cad, 2-15
 Sleeve, .385B .62D .62 Cd.Cad, 2-17
 Sleeve, .408B .62D .53Stl, 2-95
 Sleeve, .438B 1.00D .35 Stl, 2-117
 Sleeve, .531B .99D1 .75 Stl, 2-41
 Sleeve, 0.406B .750D .800Stl, 3-33
 Sleeve, 0.406B 0.75D1.80 Stl, 2-117, 3-33
 Sleeve, Bearing–Rear, 5-21
 Sleeve, Bearing, 2-53
 Sleeve, Hyd 30", 2-119
 Sleeve, Nylon #27 65.0L, 2-113
 Sleeve, Nylon #27 55.Ol, 3-35
 Sleeve, Pivot, Door, 2-43
 Sleeve,0.406B .750D .800 Stl, 2-117
 Sleeve, 5-7, 5-13, 5-21
 Sliding Glass, 3-45
 Spacer .77Od .406ld 1.318Lg, 3-31
 Spacer En, 4-37
 Spacer Plate, 4-21, 4-22, 4-25
 Spacer, .25 L, 2-111
 Spacer, .90L, 2-111
 Spacer, Bearing, 5-17
 Spacer, Brake, 2-93
 Spacer, Glass, 3-43
 Spacer, Pulley, 2-115, 2-117, 3-31, 3-33
 Spacer–.50 Od X .055W X 1.0, 2-93
 Spacer, 2-33, 2-35, 2-49, 2-57, 2-59, 2-75, 2-77, 2-93, 2-95, 2-113, 2-115, 2-117, 2-127, 2-129, 3-19, 3-31, 3-33, 3-35, 3-43
 Spindle, Adjustment, 2-19, 2-21, 3-65
 Spindle, Idle Gear, 5-11
 Sponge Cord 1.5Dia, 2-7
 Spring En, 4-37
 Spring Assy, Recirculation, 2-7
 Spring En, 4-5, 4-9, 4-13, 4-17, 4-37
 Spring Kit, 4-36
 Spring Set, 5-21
 Spring, Brush, 5-21
 Spring, Cntr En, 4-39
 Spring, Cntr, 4-41
 Spring, Comp. Cl, 4-25
 Spring, Comp.75Od0.09Wire 0.8L, 2-59
 Spring, Comp, 2-113, 3-35
 Spring, Exhaust Valve, 5-11
 Spring, Extension, 2-113, 3-35
 Spring, Friction Gear, 5-9
 Spring, Gas 80 Lb, 3-49
 Spring, Gas, 2-21
 Spring, Oil Pressure, 5-19
 Spring, Propel, Centering, 2-95
 Spring, Recirculation, 2-9
 Spring, Rocker Arm, 5-11
 Spring, Tens,0.5Dx.06Wire 2.5L, 2-93
 Spring, Tension, 2-79, 2-121
 Spring, Torsion , Rh, 2-113
 Spring, Torsion, 3-35
 Spring, Valve Intake, 5-11
 Spring, Valve, 5-19
 Spring,Retainer En, 4-39
 Spring,Retainer, 4-41
 Spring–Gas 120Lb 6.3 Stroke, 2-19
 Spring–Gas 75Lb 6.3 Stroke, 2-19
 Spring–Gas Assy, 2-45
 Spring–Gas, Engine Cover, 2-47
 Spring, 2-53, 4-19, 5-19
 Sprng, Tens,1.000dx.09Wire2.8 L, 2-95
 Sprng,Comp,0.62ldx.06Wire 2.3L, 2-133
 Sprng,Comp,0.74ldx.11Wire 1.5L, 3-21
 Sprng,Comp,0.75Od0.09Wire 0.8L, 2-57
 Sprng,Comp,0.83ldx.07Wire 1.0L, 3-59, 3-61
 Sprng,Comp,0.87ldx.10Wire 2.5L, 2-123, 2-125
 Sprng,Tens,0.37Odx.05Wire 4.5L, 2-19, 3-25
 Sprng,Tens,0.965Odx.09Wire4.4L, 2-45, 2-47, 3-21
 Starter, 5-21
 Stay, Injection Pump, 5-15
 Steer Control Hyd#4 04.5 1300, 4-26

CROSS REFERENCE

Steer Control, Hyd#4 04.5 1300, 4-25
Steer Control, Hyd, 2-133
Stopper Set, 5-21
Strain,Relief, 2-55, 3-73
Strainer, Oil, 5-19
Strainer–Hyd Suction 25–100–03, 2-3, 2-105
Strap Weldmt, Gas Tank, 2-71
Strap Wldt, A/C Cover, 3-51
Strap, Alternator, 5-22
Strap, Mtg, Air Cleaner, 3-51
Strap, Retainer, Seal, 2-3, 2-7, 2-9
Strap, Shipping En, 4-5, 4-13
Strap, Tank, Gas, 2-69
Striker Assy, 3-45
Strip, Hopper, 2-39
Strip, Retainer, Bearing, 2-119
Strip, Retainer, Brake Cable, 2-93
Strip, Retainer, Seal, Lh, 2-11
Strip, Retainer, Seal, Rh, 2-13, 3-31
Strip, Retainer, Seal, Side, 2-11, 2-13
Strip, Retainer, Shield, Lh, 2-7, 2-9
Strip, Retainer, Shield, Rh, 2-7, 2-9
Strip, Retainer, Skirt, Front, 2-37, 2-39
Strip, Retainer, Skirt, Rear, 2-37
Strip, Retainer, Skirt, 2-3, 2-11, 2-13, 3-63
Strip, Spacer, 2-19, 2-21
Strip, 2-19, 3-53, 3-55
Stud, Adjustment, 3-59, 3-61
Stud, Ball, Gas Spring, 2-19, 2-21, 2-115, 3-31
Stud, 5-3, 5-5, 5-7, 5-12
Support Wldt, Hopper Lh, 2-51
Support Wldt, Sppt, Hopper Lh, 2-51
Switch Assy, Hopper, Angle, 2-49
Switch Assy, Pressure, Hyd, 2-107
Switch Brkt Heat De, 4-49, 4-51
Switch Ignition, 2-135
Switch Rocker Spst, 2-117, 3-33
Switch, Blower, 4-45, 4-47, 4-49, 4-51
Switch, Pressure, Oil, 2-57, 2-59
Switch, Pressure, 2-55, 3-73
Switch, Pushmom, Spst100A 12V, 2-133
Switch, Rocker, Dpdt, 2-135

Switch, Roller, 2-31, 2-115, 3-15, 3-16, 3-31
Switch, Thermo, 4-45, 4-47
Switch, Wiper Motor, 3-43
Switch,Lockout En, 4-39
Switch, 5-21
Swivel, 3-21

T

Tank Wldt, Hyd , 2-105
Tank Wldt, Hydraulic, 2-105
Tank, Fuel, 2-69, 2-71
Tappet, 5-11
Thermostat Assembly, 155 Deg, 2-131
Thermostat, 5-17
Tie Cable 3.00D Max 11.41Lg, 2-113, 3-35
Tie, Cable 1.75D Max 7.50Lg, 2-55
Tie, Cable 1.75D Max 7.50Lg, 3-11, 3-13, 3-73
Tie, Cable 3.00D Max 11.41Lg, 2-69, 2-133
Tie, Cable 4.00 Max 14.50Lg, 3-73
Tie, Cable, 3-3, 3-5, 3-7, 3-9
Tire & Flap Assy, 2-91
Tire & Rim Assy, Pneu 6.50–10, 2-91
Tire and Rim Assembly, Solid 6.50–10, 3-68
Tire and Rim Assy, Rear, Solid 6.5, 3-69
Tire, Solid, 3-68, 3-69
Tread, Floormat, Rubber, Cab, 3-43
Tread, Floormat, Rubber, 2-15, 2-17
Tube Assy, Brake,Metric 34.0Lg, 2-93
Tube Assy, Brake,Metric 80.0Lg, 2-93
Tube Assy, Brake, 2-93
Tube Wldt, Air Cleaner, 2-63, 2-65
Tube Wldt, Brace, Center, 2-19, 2-21
Tube, .75D .172W .75 Stl, 3-31
Tube, 0.62D .44B 2.44,Stl, 2-45
Tube, 0.62D .44B 2.44, Stl, 2-47, 3-49
Tube, 2.50D 2.380 21.0,Stl, 2-63
Tube, 3.00D 2.88B 3.00,Stl Dom, 3-23
Tube, Air Cleaner, Die, 2-63, 2-65
Tube, Air Cleaner, 2-63
Tube, Blower Wand, 3-19, 3-23
Tube, Cross, Bumper, Se, 3-27, 3-28, 3-29
Tube, Extension, 2-67

Tube, Inner, 2-91
 Tube, Radiator, Die, 2-73
 Tube, Radiator, Upper, Die, 2-73
 Tube, Retainer, Spring, 2-121
 Tube, Silicone, 5-7
 Tube, Spacer, Brush Lift, 2-121

V

V-Belt .47 42.50Lg, 3-57
 Valve – Hyd., Solenoid, 4-28
 Valve Mountng Brkt De, 4-45, 4-47, 4-49, 4-51
 Valve Plate, 4-5, 4-9, 4-13, 4-17, 4-19
 Valve Spool, 4-41
 Valve Stem N.O. CP, 4-31, 4-33, 4-35
 Valve Stem N.O., 4-27
 Valve Stem 4W2P CP, 4-31, 4-33, 4-35
 Valve Stem 4W2P, 4-29
 Valve Stem, N.D., 4-28
 Valve, Check, 4-45, 4-47
 Valve, Exhaust, 5-11
 Valve, Hyd Control Man (See Breakdowns), 2-111
 Valve, Hyd Control Man, 4-37
 Valve, Hyd Control Solenoid, 4-29, 4-35
 Valve, Hyd Solenoid (See Breakdowns), 2-117
 Valve, Hyd Solenoid, 2-117
 Valve, Hyd, (Repl. by 77496) (See Breakdowns),
 2-109
 Valve, Hyd, Control Solenoid, 3-33
 Valve, Hyd, Solenoid (See Breakdowns), 3-33
 Valve, Hydraulic, 4-36
 Valve, Intake, 5-11
 Valve, Oil Jet, 5-7
 Valve, Push Nut Water, 4-45, 4-47, 4-49, 4-51
 Valve-Hyd, Cntl Solenoid, 4-31
 Valve-Hyd, Solenoid (See Breakdowns), 2-107,
 2-131, 3-35
 Valve-Hyd, Solenoid , 2-131
 Valve-Hyd, Solenoid, 4-27, 4-33
 Valve, 4-19
 Vlv Spool Wide En, 4-39

W

Wand Kit, Vac, 3-61
 Wand Kit, Vacuum, 3-59
 Wand, 3-59, 3-61
 Warning Kit, Backup Low Blower, 3-16
 Warning Kit, Backup, 3-15
 Washer En, 4-3, 4-5, 4-7, 4-9, 4-11, 4-13, 4-15,
 4-17, 4-37
 Washer Flt .31 Hard, 2-71
 Washer, .310B .88D .12Rbr, 2-41, 3-35
 Washer, .344B .69D .06Nylon, 3-73
 Washer, .375B .75D .06Nylon, 2-57
 Washer, .375B .75D .06Nylon, 2-59
 Washer, .531B 1.75D .12Cr.Znc, 2-119
 Washer, .531B 1.88D .12Hard Zn, 2-17
 Washer, .532B 2.13D .11Hr.Znc, 2-57
 Washer, .532B 2.13D .11Hr.Znc, 2-59
 Washer, 1.015B 1.75D .11Hrs, 2-43
 Washer, 1.300B 3.000, 2-113, 3-35
 Washer, Flat, 2-15
 Washer, Lock, 5-11
 Washer, Nozzle, 5-15
 Washer, Plain, 5-3, 5-5, 5-9, 5-13
 Washer, Sealing, 5-3
 Washer, Spring, 5-19
 Washer,1.142B 1.75D .07 Lcs, 2-33
 Washer,Lock Special, 2-87
 Washer,Nyl,0.26 Bx0.72 X.07 Th, 3-21
 Washer,Nyl,0.405Bx0.812X.060Th, 3-31
 Washer-Belleville .31 Pltd, 3-33
 Washer-Belleville .50 Pltd, 2-113
 Washer-Belleville .50 Pltd, 3-35
 Washer-Flt .31 Fender Pltd, 2-109
 Washer-Flt .25 Fender Rltd., 2-17
 Washer-Flt .31 Fender Pltd, 2-111
 Washer-Loc Int-Ext .31 Pltd, 3-41
 Washer, 2-55, 2-87, 4-3, 4-7, 4-11, 4-15, 5-7, 5-9,
 5-11, 5-15, 5-19
 Water Screen Foam De, 4-45, 4-47
 Water Valve, 4-45, 4-47, 4-49, 4-51
 Weight, Die, 2-9
 Wheel, Steering, 2-133
 Wire Ass'Y-Elect.,Ground, 2-59

CROSS REFERENCE

Wire Assy., Elect. Ground, 2-57
Wire Assy, 42.0 Lg, 2 Ga, Neg, 2-83
Wire Assy, 66.0 Lg, 2 Ga, Pos, 2-83
Wire Ground, Alternator, 2-61
Wire Harness, 3-55, 4-45, 4-47, 4-49, 4-51
Wire, 42.0 Lg, 2Ga, Neg, 2-85
Wire, Dome Light, 3-43
Wire, Ground, Alternator, 3-57
Wire, Lead, 2-21
Wire—Ground, Alternator, 3-25

Y

Yoke, 5-21

Fold along dotted lines

Tape here



NO POSTAGE
NECESSARY
IF MAILED
IN THE
UNITED STATES

BUSINESS REPLY MAIL
FIRST CLASS MAIL PERMIT NO. 94 MINNEAPOLIS, MN

POSTAGE WILL BE PAID BY ADDRESSEE

TENNANT COMPANY

Technical Publications #15
701 North Lilac Drive
P.O. Box 1452
Minneapolis, MN 55440-9947

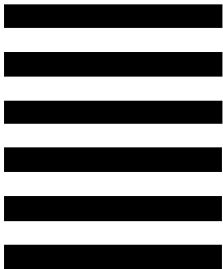

Fold along dotted lines

Tape here



NO POSTAGE
NECESSARY
IF MAILED
IN THE
UNITED STATES

BUSINESS REPLY MAIL

FIRST CLASS MAIL PERMIT NO. 94 MINNEAPOLIS, MN

POSTAGE WILL BE PAID BY ADDRESSEE

TENNANT COMPANY

Technical Publications #15
701 North Lilac Drive
P.O. Box 1452
Minneapolis, MN 55440-9947

