

Issued by  
Siemens Home and Office Communication Devices GmbH & Co. KG  
Schlavenhorst 66  
D-46395 Bocholt

© Siemens Home and Office Communication Devices GmbH & Co. KG 2006  
All rights reserved. Subject to availability.  
Rights of modification reserved.

[www.siemens.com/gigaset](http://www.siemens.com/gigaset)

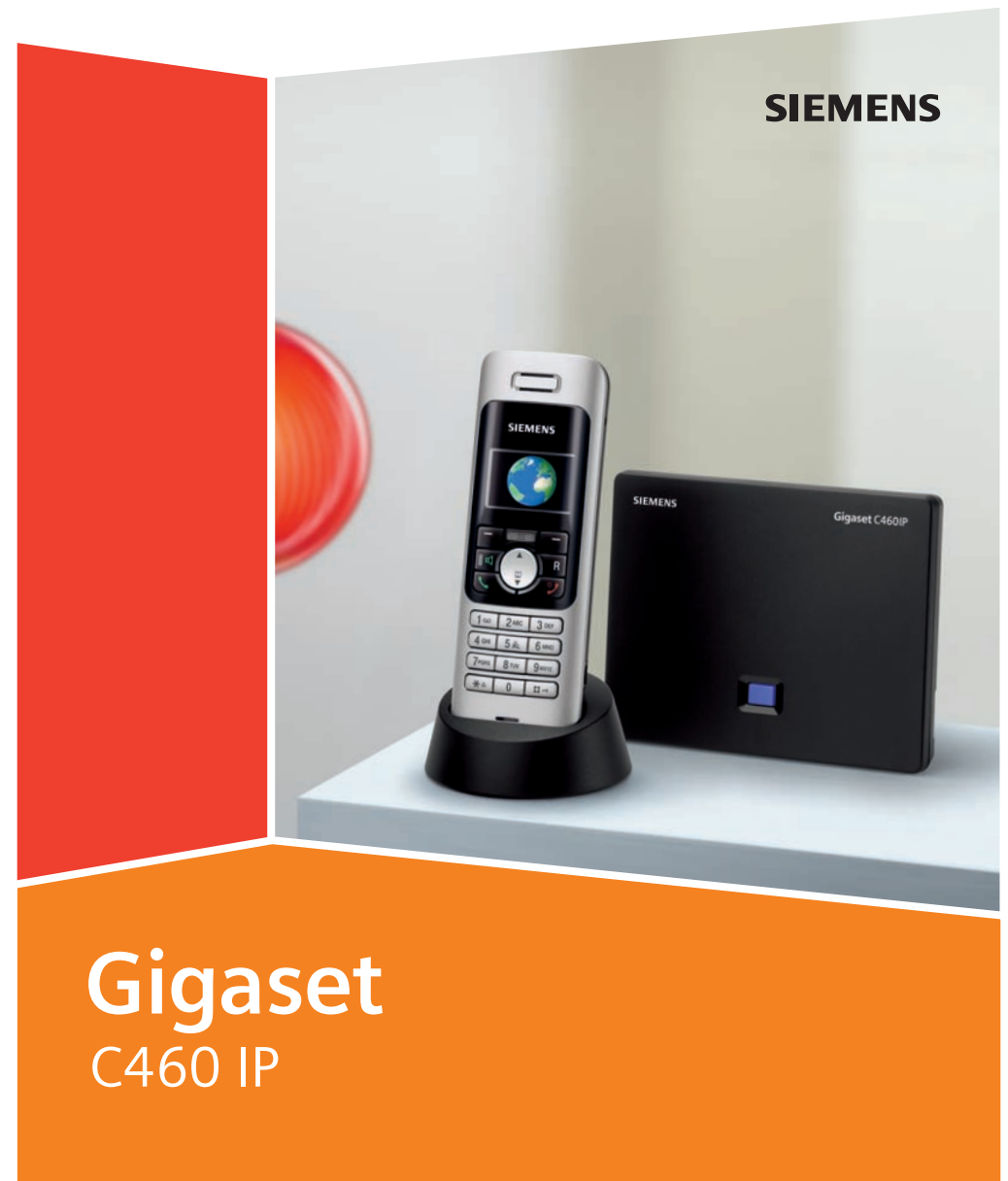

**SIEMENS**

**Gigaset**  
C460 IP

## The handset at a glance

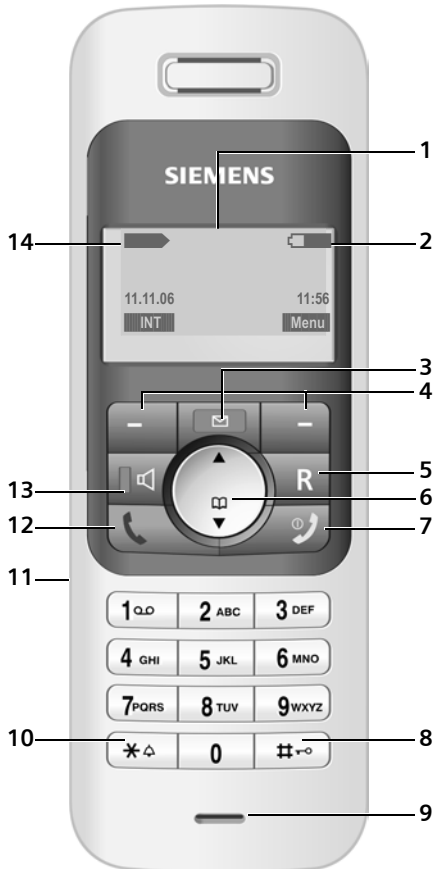

### Handset keys

- 1 **Display** in idle status (example)
- 2 **Battery charge level**  
  - (1/3 charged to fully charged)
  - flashes: battery almost flat
  - flashes: battery charging
- 3 **Message key**  
 Opens calls and message lists  
 Flashes: new message or new call
- 4 **Display keys** (page 19)
- 5 **Recall key**  
 Enter flash (press briefly)  
 Insert a pause (press and hold)
- 6 **Control key** (page 18)
- 7 **End call key, On/Off key**  
 End call, cancel function, go back one menu level (press briefly), back to idle status (press and hold), activate/deactivate handset (press and hold in idle status)
- 8 **Hash key**  
 Keypad lock on/off (press and hold, page 18)  
 Toggle between upper/lower case letters and digits for text entry
- 9 **Microphone**
- 10 **Star key**  
 Ringer tones on/off (press and hold in idle status),
- 11 **Connection socket for headset**
- 12 **Talk key**  
 Answer a call, open last number redial list (press briefly), start dialling (press and hold)
- 13 **Handsfree key**  
 Switch between earpiece and handsfree mode  
 Lights up: handsfree activated  
 Flashes: incoming call
- 14 **Signal strength**  
  - (low to high)
  - flashes: no reception

## Base station at a glance

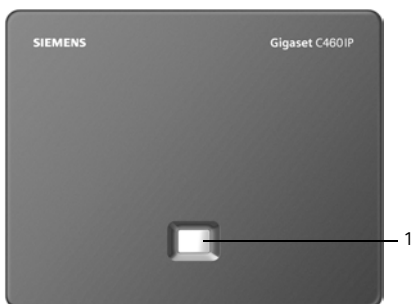

### Base station key

- 1 **Paging key**  
 Lights up: LAN connection active (phone is connected to router)  
 Flashes: data transfer to LAN connection  
 Press **briefly**: start paging  
 Press and **hold**: set base station to registration mode

# Contents

- The handset at a glance . . . . . 1**
- Base station at a glance . . . . . 1**
- Safety precautions . . . . . 3**
- Gigaset C460 IP –  
more than just making calls . . . . 4**
- VoIP – Making calls via the  
Internet . . . . . 5**
- First Steps . . . . . 5**
  - Pack contents . . . . . 5
  - Setting up the handset for use . . . . . 6
  - Installing the base station . . . . . 8
  - Connecting the base station . . . . . 9
  - Making settings for VoIP telephony . . 11
- Menu tree . . . . . 14**
- Making calls with VoIP and the  
fixed network . . . . . 17**
  - Making an external call . . . . . 17
  - Ending a call . . . . . 17
  - Answering a call . . . . . 17
  - Switching between earpiece and  
handsfree mode . . . . . 17
  - Setting and dialling emergency  
numbers . . . . . 18
- Operating the handset . . . . . 18**
  - Switching the handset on/off . . . . . 18
  - Activating/deactivating the  
keypad lock . . . . . 18
  - Control key . . . . . 18
  - Display keys . . . . . 19
  - Returning to idle status . . . . . 19
- VoIP telephony via the  
Gigaset.net . . . . . 19**
  - Calling up the Gigaset.net directory . . 20
  - Entering your own name . . . . . 20
- Using the directory and lists . . . 21**
  - Directory . . . . . 21
  - Last number redial list . . . . . 21
  - Opening lists with the message key . . 22
  - Dialling with directory/list . . . . . 22

- SMS (text messages) . . . . . 23**
  - Writing/sending/saving SMS . . . . . 23
  - Receiving/reading SMS . . . . . 23
  - Managing SMS lists . . . . . 23
- Setting handset/base station . . 24**
  - Adjusting the loudspeaker volume . . . 24
  - Setting the ringer volume . . . . . 24
  - Activating/deactivating advisory  
tones . . . . . 24
  - Using the handset as an  
alarm clock . . . . . 25
  - Changing the base station  
system PIN . . . . . 25
  - Restoring the handset default  
settings . . . . . 25
  - Restoring the base station to  
factory settings . . . . . 26
  - Setting the default connection . . . . . 26
  - Assigning the phone  
a fixed IP address . . . . . 26
- Web configurator . . . . . 27**
  - Connecting your PC to the Web  
configurator . . . . . 27
  - De-registering . . . . . 27
  - Web configurator functions . . . . . 27
- Appendix . . . . . 29**
  - Care . . . . . 29
  - Contact with liquid . . . . . 29
  - Questions and answers . . . . . 29
  - Service (Customer Care) . . . . . 29
  - Approval . . . . . 30
  - Guarantee Certificate  
United Kingdom . . . . . 30
  - Specifications . . . . . 31
  - Gigaset C460 IP – Free software . . . . 32

# Safety precautions

## Caution:

Read the safety precautions and the user guide before use.

Explain their contents to your children, and the potential hazards associated with using the telephone.



Only use the mains adapter supplied, as indicated on the underside of the base station.



Fit only the **recommended rechargeable batteries (page 31)** of the same type! This means that you must never use any other battery type or non-rechargeable batteries as this could result in significant health risks and personal injury.



Insert rechargeable batteries with the correct polarity, and use them according to this user guide (polarity symbols can be seen in the handset's battery compartment, page 6).



The operation of medical appliances may be affected. Be aware of the technical conditions in your particular environment, e.g. doctor's surgery.



Do not hold the rear side of the handset to the ear when it rings or when you have activated on the handsfree function. Otherwise you risk serious and permanent damage to your hearing.

The handset may cause an unpleasant humming noise in hearing aids.



Do not install the base station in bathrooms or shower rooms. The handset and base station are not splashproof (page 29).



Do not use your phone in environments subject to explosion hazard, e.g. paint shops).



If you give your Gigaset to someone else, make sure you also give them the user guide.



All electrical and electronic products should be disposed of separately from the municipal waste stream via designated collection facilities appointed by the government or the local authorities.

This crossed-out wheeled bin symbol on the product means the product is covered by the European Directive 2002/96/EC.

The correct disposal and separate collection of your old appliance will help prevent potential negative consequences for the environment and human health. It is a precondition for reuse and recycling of used electrical and electronic equipment.

For more detailed information about disposal of your old appliance, please contact your city office, waste disposal service or the shop where you purchased the product.

## Please note:

**Emergency numbers cannot be dialled if the key lock is activated!**

Not all of the functions described in this user guide are available in all countries.

## Gigaset C460 IP – more than just making calls

Your phone lets you make calls both via the fixed network and (cost effectively) via the Internet (VoIP) **without using a PC**.

And your phone can do much more:

- ◆ **Press a button** each time you make a call to indicate whether you want to make a call via the fixed network or via the Internet (page 17).
- ◆ Register up to **six** handsets on your base station. Your base station allows you to use one handset to make a call via the fixed network and another to make a call via the Internet at the same time.
- ◆ Use the Gigaset.net for VoIP calls. Connect your phone to the power supply and the Internet, and enjoy free phone calls on the Gigaset.net – no need to make any other settings (page 19).
- ◆ Configure the phone connection for VoIP without a PC. Your phone's connection wizard downloads general data about your VoIP provider from the Internet and guides you through entering your personal data (account). This makes it easy for you to start using VoIP (page 11).
- ◆ Establish any further required VoIP settings on a PC. The phone has a Web interface (**Web configurator**) that can be accessed via your PC's Web browser (page 27).
- ◆ Assign your own password (system PIN) to protect your device and the Web configurator from unauthorised access (page 25).
- ◆ Send and receive SMS messages via the fixed network (page 23).

- ◆ Save 100 phone numbers on your handset (page 21).
- ◆ You can programme the keys of your phone with important phone numbers. The phone number is then dialled by simply pressing the respective key (page 21).
- ◆ Keep your hands free when making a call. Use the handsfree function on your handset (page 17) or use the convenient headset to make calls (accessory: not included in the scope of delivery).
- ◆ Make sure your phone is always up-to-date. Arrange to be informed about **firmware updates** on the Internet and download these onto your phone.
- ◆ Use your handset as an alarm clock (page 25).

For more information, please see the full user guide for your Gigaset C450 IP on the Internet at [www.siemens.com/gigaset](http://www.siemens.com/gigaset).

Your Gigaset C450 IP has a protected operating system that offers increased security **against viruses** from the Internet.

**Have fun using your new telephone!**

## VoIP – Making calls via the Internet

---

With VoIP (Voice over Internet Protocol), your calls are not made via a fixed connection as in the telephone network, but rather they are transmitted via the Internet in the form of data packets.

You can take advantage of all the benefits of VoIP with your phone:

- ◆ You can make cost-effective calls with high voice quality with subscribers on the Internet, the fixed network or the mobile phone network.
- ◆ Your VoIP provider will give you a personal number, with which you can be reached from the Internet, the fixed network and any mobile phone network.

To be able to use VoIP, you need the following:

- ◆ A broadband Internet connection (e.g. DSL) with flat rate or volume-based price.
- ◆ Internet access, i.e. you need a router that will connect your phone to the Internet. You can find a list of recommended routers on the Internet at: <http://siemens.com/qigaset>
- ◆ Access to the services of a VoIP provider. Open an account with a VoIP provider.

## First Steps

---

### Pack contents

---

The pack contains:

- ◆ one Gigaset C460 IP base station
- ◆ one Gigaset C46 handset
- ◆ one mains adapter for the base station
- ◆ one charging cradle incl. mains adapter
- ◆ one phone cord
- ◆ one Ethernet cable (LAN cable)
- ◆ two batteries
- ◆ one battery cover
- ◆ one belt clip
- ◆ one quick guide

### Documentation

A more detailed description of your Gigaset C460 IP and your Web configurator is available on the Internet at:

[www.siemens.com/qigaset](http://www.siemens.com/qigaset)

This full description is in PDF format. You will need Adobe® Reader® to view these documents. Adobe® Reader® is available on the Internet at [www.adobe.com](http://www.adobe.com).

## Setting up the handset for use

The display is protected by a plastic film. **Please remove the protective film!**

### Inserting the batteries

**Caution:**

Use only the rechargeable batteries recommended by Siemens on page 31! This means that you must never use conventional (non-rechargeable) or other battery types as this could result in significant health risks and damage to property. For example, the outer casing of the batteries could be destroyed or the batteries could explode. The phone could also malfunction or be damaged as a result of using batteries that are not of the recommended type.

- ▶ Fit the batteries with the correct polarity (see diagram).

The polarity is indicated in/on the battery compartment.



### Closing the battery cover

- ▶ First align the notches on the side of the battery cover with the lugs on the inside of the casing.
- ▶ Then press the cover so that it clicks into place.



### Attaching the belt clip

There are notches for attaching the belt clip on the side of the handset at the same height as the display.

- ▶ Press the belt clip onto the back of the handset so that the protrusions on the belt clip engage with the notches.

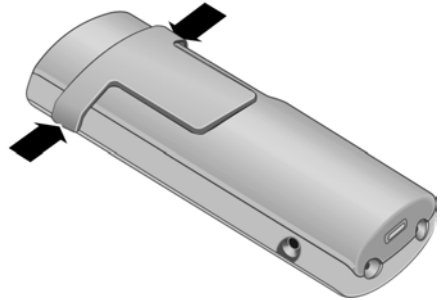

## Opening the battery cover

- ▶ If fitted, remove belt clip.
- ▶ Insert a fingernail into the headset socket cavity and pull the battery cover upwards.

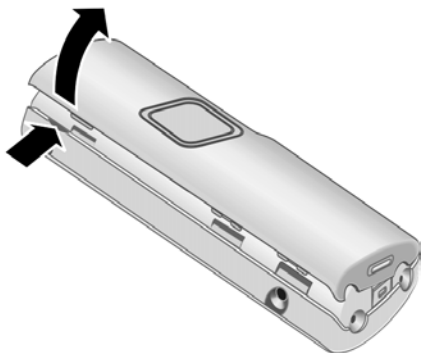

## Connecting the charging cradle



Connecting the charging cradle is described at the end of this user guide.

- ▶ To charge the batteries, leave the handset in the charging cradle.

### Please note:

- Only place the handset in the charging cradle that is intended for it.
- If the handset has switched itself off because the batteries are flat and if it is then placed in the charging cradle, it will switch itself on automatically.

## Initial charging and discharging of batteries

Battery charging is indicated in the top right of the display by a flashing battery icon ,  or . During handset operation, the battery icon indicates the charge status of the batteries (page 1).

The correct charge status can only be displayed when the batteries are first fully charged **and** discharged through use.

- ▶ To do this, leave the handset in the charging cradle without interruption until the battery icon stops flashing in the display (approx. 13 hours).

- ▶ Once the batteries are fully charged, remove the handset from the charging cradle and do not put it back again until the batteries are fully discharged.

### Please note:

After the first battery charge **and** discharge, you may replace your handset in the charging cradle after every call.

### Please note:

- ◆ Always repeat the charging and discharging procedure if you remove the batteries from the handset and insert them in again.
- ◆ The batteries may warm up as they are charging. This is not dangerous.
- ◆ After a while the charge capacity of the batteries will decrease for technical reasons.

## Setting the date and time

**Menu** → **Settings** → **Date/Time**



Enter the day, month and year with 6 digits and press **OK**.

Use  to move between the fields.



Enter hours and minutes with 4 digits (e.g. 07 15 for 07.15 hrs) and press **OK**.

Use  to move between the fields.

The date and time are shown in the handset's idle display (page 1).

## Registering the handset to the base station

Your handset is registered to the base station by default.

For how to register other handsets to the base station and make internal calls free of charge, please see the full user guide (page 5).

## Installing the base station

The base station is designed for use in closed, dry rooms with a temperature range of +5 °C to +45 °C.

- ▶ Install/hang your base station at a central point in the house.

### Mounting the base station on a wall

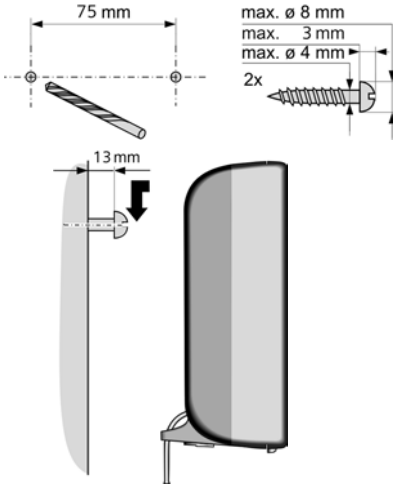

### Please note:

- ◆ Never expose the telephone to heat sources, direct sunlight or other electrical appliances.
- ◆ Protect your Gigaset from moisture, dust, corrosive liquids and vapours.

## Connecting the base station

In order to be able to make calls with your phone via the fixed network and via VoIP, you must connect the base station to the fixed network and the Internet, see Figure 1.

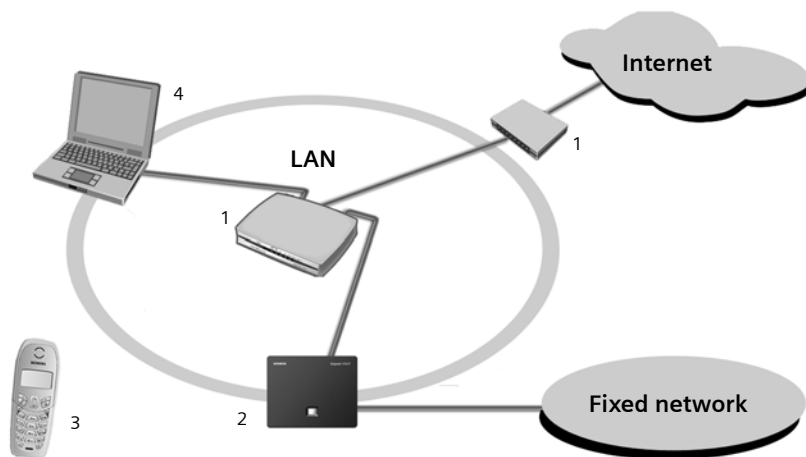

Figure 1 Connecting the phone to the fixed network and the Internet

- 1 Internet connection:  
Router with integrated modem or  
router and modem
- 2 Gigaset C460 IP base station
- 3 Gigaset C46 handset
- 4 PC in LAN

Follow the steps in the order given below:

1. Connect the base station with the fixed network phone connection
2. Connect the base station with the mains power supply
3. Connect the base station with the router

## Connecting the base station with the fixed network and the mains power supply

- ▶ Please first connect the phone jack and then the mains adapter, as shown below.

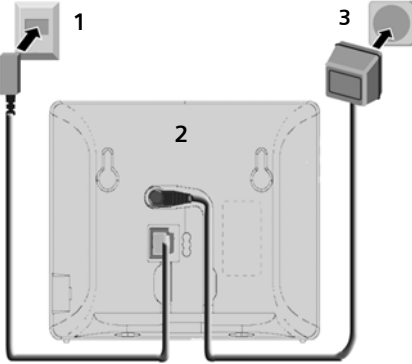

- 1 Phone jack with phone cord
- 2 Underside of the base station
- 3 Mains adapter 230 V

### Please note:

- ◆ Keep the mains adapter plugged in at all times for operation, as the phone does not work without mains connection.
- ◆ If you buy a replacement phone cord from a retailer, ensure that the phone jack is connected correctly.

### Correct phone jack assignment

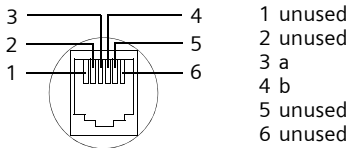

You can now use your phone to make calls via the fixed network and can be reached at your fixed network number!

## Connecting the base station with the router

For Internet access you need a router, connected to the Internet via a modem (if necessary, this can be integrated in the router).

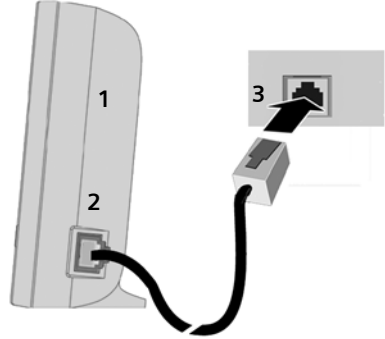

- 1 Side view of the base station
- 2 Network plug (LAN) with network cable
- 3 Router network plug

As soon as the cable connecting the phone and router is plugged in, the paging key lights up on the front of the base station.

You are now able to make VoIP connections within the Gigaset.net (page 19).

## Making settings for VoIP telephony

Before you can use the Internet (VoIP) to phone any other users on the Internet, the fixed network or the mobile phone network, you need the services of a VoIP provider who supports the VoIP SIP standard.

**Precondition:** You have registered with a VoIP provider (e.g. via your PC) and set up an account.

The following phone settings are necessary in order for you to use VoIP. You will receive all information from your VoIP provider.

- ◆ Your user name with the VoIP provider, if this is required by the VoIP provider
- ◆ Your registration name
- ◆ Your password with the VoIP provider
- ◆ VoIP provider general settings

The connection wizard will help you with the settings.

### Starting the connection wizard

**Precondition:** The base station is connected to the mains power supply and the router. Your router is connected to the Internet.

**Tip:** If VoIP (IP) is activated as the default connection for your phone (default setting page 26), the phone will attempt to make a direct connection to the server belonging to your VoIP provider after the connection wizard is closed. If incorrect/incomplete information means that the connection cannot be made, messages will be displayed (page 13).

#### Note:

Your phone is preconfigured for dynamic assignment of the IP address. In order for your router to "recognise" the phone, dynamic IP address assignment (the router's DHCP server) must also be activated on the router.

Once the handset battery is sufficiently charged, the message key  on the handset will flash (around 20 minutes after you have put the handset in the charging cradle).

- ▶ Press the message key .

You will see the following display:

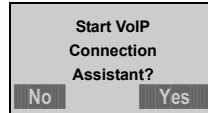

**Yes**

Press the display key to start the connection wizard.



Enter the system PIN of the base station (the default is 0000) and press **OK**.

#### Please note:

The connection wizard will also start automatically if you try to establish a connection via the Internet, before you have made the necessary settings.

You can also call up the connection wizard at any time via the menu (page 16).

## First Steps

### Downloading VoIP provider data

The phone establishes a connection with the Siemens server on the Internet. Profiles with general access data for various VoIP providers can be downloaded here. The message **Select country** is displayed.

After changing the display:

 Select country and press **OK**.

**Select provider** is displayed.

After changing the display:

 Select VoIP provider and press **OK**.

The necessary data for your VoIP provider is downloaded and saved on the phone.

#### Note:

If the data for your VoIP provider is not available for download, you must make the necessary settings with the Web configurator at a later stage (page 27).

Press the display key **Back** to carry out the following steps of the connection wizard (see "Entering VoIP user data").

### Entering VoIP user data

Depending on the VoIP provider, the following information will be requested in sequence:

**Username:**

If this is required by your provider, enter name and press **OK**.

**Authentication Name:**

Enter name and press **OK**.

**Authentication Password:**

Enter password and press **OK**.

#### Note:

Please note when making these entries that the VoIP user data is case sensitive. Press and hold the **# + ↶** key if necessary to switch between upper/lower case text and numerical entry.

If you have made all the necessary entries, the Gigaset.net wizard is started. You have the option of entering yourself in the **Gigaset.net** online directory with a name.

This step is only carried out when you are getting started (when the connection assistant is started up for the first time). You can also create the entry via the Gigaset.net directory (page 20).

For more information on this, please see the full user guide on the Internet at: [www.siemens.com/gigaset](http://www.siemens.com/gigaset).

### Completing the VoIP settings

Once all the necessary entries have been made, the handset reverts to idle status.

If all the settings are correct and if the phone can make a connection to the VoIP server, then the internal name of the handset will be displayed:

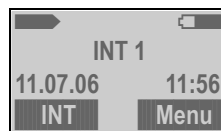

**You can now use your phone to make calls via the fixed network and the Internet! Callers can reach you on your fixed network number and your VoIP number!**

#### Please note:

To ensure that you can always be reached via the Internet, the router should be permanently connected to the Internet.

## No connection to the Internet/VoIP server

If one of the following messages is displayed instead of the internal name after the connection wizard is closed, then either a fault has occurred or your information was incomplete:

### Server not accessible!

The phone has no connection to the Internet.

- ▶ Check the cable connection between the base station and the router (the LED on the base station must light up) and the connection between the router and the modem/Internet connection.
  - ▶ Check whether the phone is connected to the LAN.
    - It may not have been possible to dynamically assign an IP address to the phone
- or

- You have assigned a static IP address to the phone that has either already been assigned to another LAN subscriber or does not belong to the router's address block.

- ▶ Find the IP address using the handset menu:

**Menu** → **Settings** → **Base**  
 → **Local Network** → (enter system PIN) → **IP Address**

- ▶ Start the Web configurator with the IP address (page 27).
- ▶ If no connection can be established: change the settings on the router (activate DHCP server) or the phone's (static) IP address.

## SIP registration failed!

- ◆ Your personal data for registering with the VoIP provider may have been entered incompletely or incorrectly.
  - ▶ Check your entries for **Username**, **Authentication Name** and **Authentication Password**. Particularly check your use of upper and lower case. To do this, open the following menu on your handset:  
**Menu** → **Settings** → **Base**  
 → **Telephony** → **VoIP**
- ◆ The server address for the VoIP server has not yet been entered, or has been entered incorrectly.
  - ▶ Start the Web configurator.
  - ▶ Open **Settings** → **Telephony** → **VoIP** Web page.
  - ▶ Edit the server address where necessary.

### Note:

If port forwarding is activated on your router for the ports that have been registered as the SIP port (Standard 5600) and the RTP port (Standard 5004), then it makes sense to switch off DHCP and assign the phone a static IP address (otherwise you may not be able to hear the other party during VoIP calls), see page 26.

Please note that the IP address and subnet mask depend on the router's address block. You must also enter the default gateway and DNS server via the Web configurator (page 27). The IP address for the router is generally entered here.

# Menu tree

There are two ways to select a function:

- ◆ Using the number combinations in the following menu tree ("shortcut")
  - ▶ **Example:** **Menu** 4 2 2 for "Set handset language".
- ◆ Scrolling through the menus
  - ▶ Press **Menu**, scroll to the function with the control key  and press **OK**

## 1 SMS

1-1	Write Message				
1-2	Incoming 00+00				
1-3	Outgoing				
1-6	Settings	1-6-1	Service Centres	1-6-1-1	Service Centre 1
				...	[to]
				1-6-1-4	Service Centre 4
		1-6-3	Register to Service Centres		

## 2 Alarm Clock

2-1	Activation
2-2	Wake up time

## 3 Audio Settings

3-1	Ringer Volume		
3-2	Ringer Melody	3-2-1	External Calls
		3-2-2	Internal Calls
		3-2-3	Alarm Clock
3-3	Advisory Tones		
3-4	Battery Low	3-4-1	Off
		3-4-2	On
		3-4-3	During Call

## 4 Settings

4-1	Date/Time				
4-2	Handset	4-2-1	Display	4-2-1-1	Screensaver
				4-2-1-2	Colour Scheme
				4-2-1-3	Contrast
				4-2-1-4	Backlight
		4-2-2	Language		
		4-2-3	Auto Answer		
		4-2-4	Register Handset		
		4-2-5	Reset Handset		
4-3	Base	4-3-2	Music on hold		
		4-3-3	System PIN		
		4-3-4	Base Reset		
		4-3-5	Additional Features	4-3-5-1	Repeater Mode
		4-3-6	Local Network	4-3-6-1	dynamic IP address
				4-3-6-2	IP Address
				4-3-6-3	Subnet Mask
				4-3-6-4	DNS Server
				4-3-6-5	Default Gateway
		4-3-7	Telephony	Submenu see page 16	
		4-3-8	Firmware Update		

## 5 Voice Mail

5-1	Set Key 1	5-1-1	Network Mailbox
-----	-----------	-------	-----------------

## Menu tree

### 6 Select Services \*

6-1	VoIP	6-1-6	For All Calls	6-1-6-1	Call Divert
6-2	Fixed line	6-2-3	Withhold Number		
		6-2-6	For All Calls	6-2-6-1	Call Divert
				6-2-6-3	Call Waiting
		6-2-7	Cancel Ringback		

\* Please note: Following a firmware update, the network services are only displayed if you de-register and then reregister your handset.

### Submenu "Settings → Base → Telephony" 4-3-7

4-3-7	Telephony	4-3-7-1	Default Line Type	4-3-7-1-1	IP
				4-3-7-1-2	fixed line
		4-3-7-2	Connection Assistant		
		4-3-7-6	Fixed line	4-3-7-6-1	Dialling Mode
				4-3-7-6-2	Recall
		4-3-7-7	VoIP	4-3-7-7-1	Status on HS
				4-3-7-7-2	Select VoIP Provider
				4-3-7-7-3	Username
				4-3-7-7-4	Authentication Name
				4-3-7-7-5	Authentication Password

Not all menu points are described in this quick guide. For a comprehensive description, see the full user guide for your Gigaset C450 IP on the Internet at [www.siemens.com/gigaset](http://www.siemens.com/gigaset).

## Making calls with VoIP and the fixed network

---

### Making an external call

---

External calls are those that are made via the public telephone network (fixed network) or the Internet (VoIP). You can use the talk key **☎** when dialling to select what type of connection you want to use (fixed network or VoIP). One particular connection type is set as the standard connection for your phone. The default is VoIP (this can be changed like other settings if required, see page 26).

- ▶ Enter the required number/IP address using the keypad.
- ▶ **Briefly** press the talk key **☎** if you want to make a call via this default connection.

or:

- ▶ Press and **hold** the talk key **☎** if you want to make the call via the other connection type.

#### Please note:

- To make a call in handsfree mode, you can also press briefly/press and hold the handsfree key **☎** instead of the talk key **☎**.
- If you use a different GAP-compatible handset to the Gigaset C45, all calls will be made via the standard connection, even if you press and hold the talk key **☎**. If you want to use the non-standard connection to make a call, enter a star (\*) at the end of the number.
- If you use VoIP to make a call to the fixed network, you may also have to dial the area code for local calls (depending on the VoIP provider). You can avoid this by entering the area code in the configuration of the base station (via the Web configurator). It will then be inserted automatically for local calls.

### Cancelling the dialling operation

You can cancel the dialling operation with the end call key **☎**.

### Entering an IP address

Via VoIP you can also dial an IP address instead of a phone number.

- ▶ Press the star key **\*△** to separate the IP address number blocks from each other (e.g. 149\*246\*122\*28).
- ▶ If necessary, press the hash key **#T°** to attach the SIP port number of the person you are calling to the IP address (e.g. 149\*246\*122\*28#5060).

### Ending a call

---

**☎** Press the end call key.

### Answering a call

---

The handset indicates an incoming call in three ways: by ringing, by a display on the screen and by the flashing handsfree key **☎**.

You can answer the call by:

- ▶ Pressing the talk key **☎**.
- ▶ Pressing the handsfree key **☎**.

If the handset is in the charging cradle and the **Auto Answer** function is activated (page 15), the handset will take a call automatically when you lift it out of the charging cradle.

### Switching between earpiece and handsfree mode

---

- ▶ Press the handsfree key **☎** to activate/deactivate handsfree talking during a call.

If you wish to place the handset in the charging cradle during a call:

- ▶ Hold down the handsfree key **☎** while placing the handset in the charging cradle. If the handsfree key **☎** does not light up, press the key again.

## Setting and dialling emergency numbers

You can save up to five emergency numbers on your phone. The default setting for your phone is that these emergency numbers are always dialled via the fixed network – irrespective of which connection type you select. The fixed network always supports general emergency numbers (e.g. establishing connection to the **local** police emergency number).

You can deactivate the setting for emergency numbers to always be dialled via the fixed network (**Dialling Plans**, page 28). However, you should ask beforehand, whether your VoIP provider supports emergency numbers (e.g. the local police emergency number).

You can enter or change emergency numbers in the Web configurator on the **Dialling Plans** Web page.

- ▶ Open the following Web page: **Settings** → **Telephony** → **Dialling Plans**.
- ▶ Enter your emergency numbers in the appropriate boxes in the **Emergency Numbers** section. Change emergency numbers that have already been entered.
- ▶ Click on **Set** to save the settings.

### Please note:

- You can use the Web configurator to display whether any emergency numbers are saved on your phone and, if so, which numbers.
- **Please note:** If you have used Web configurator to deactivate **Emergency calls always via fixed line** the function and then entered an automatic local area code for VoIP calls (**Settings** → **Telephony** → **Dialling Plans**), then the local area code will also be inserted before emergency numbers if they are dialled using VoIP.

## Operating the handset

### Switching the handset on/off

☞ Press and **hold** the end call key.

You will hear the confirmation tone.

### Activating/deactivating the keypad lock

#\*☞ Press and **hold** the hash key.

You will hear the confirmation tone. The ☞ icon appears in the display when the keypad lock is activated.

### Control key



1 Control key

In this user guide, the side of the control key that you must press in the given operating situation is shown in black (top, bottom). Example: ⬆ for "press the top of the control key".

The control key has a number of different functions:

#### When the handset is in idle status

- ⬆ Open the directory.
- ⬆ Adjust the ringer volume of the handset (page 24).

#### In lists and menus

- ⬆ / ⬇ Scroll up/down line by line.

**In an input field**

⬆ / ⬇ / ⬆ / ⬇ Move the cursor **left** or **right**.

**During an external call**

- ⬇ Open the directory.
- ⬇ Adjust loudspeaker volume for earpiece and handsfree mode.

**Display keys**

The current display functions are shown in the bottom display line in reversed highlights. The function of the display keys changes depending on the particular operating situation.

Example:

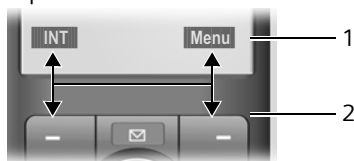

- 1 Current display key functions
- 2 Display keys

**Returning to idle status**

You wish to return to idle status from anywhere in the menu:

- ▶ Press the end call key  and hold.

Changes that you have not confirmed/saved by pressing **OK** will be rejected.

**For additional information on using your Gigaset C460 IP, please see the full user guide (page 5).**

**VoIP telephony via the Gigaset.net**

You can use the Gigaset.net to make free phone calls via the Internet **directly** to other Gigaset.net users, without having to set up an account with a VoIP provider or make any further settings! You simply have to connect your phone to the power supply and the Internet connection and, if necessary, enter yourself in the Gigaset Net online directory under a name of your choice.

**Gigaset.net** is a VoIP service from Siemens Home and Office Communication Devices GmbH und Co KG, which all users of a VoIP phone that supports Gigaset.net can use.

Every Gigaset VoIP device is automatically assigned a Gigaset.net phone number.

**Exclusion of liability**

Gigaset.net is a voluntary service provided by Siemens Home and Office Communication Devices GmbH & Co KG with no liability or warranty for the availability of the network. This service can be terminated at any time with a notice period of three months.

## Calling up the Gigaset.net directory

---

Your handset is in idle status.

- ▶ Open the directory with the  button.
- ▶ Select the <Gigaset.net> entry and press the talk key .

For information on how to find and call up phone numbers in the Gigaset.net directory, please see the full user guide on the Internet.

### Please note:

- Calls to the Gigaset.net directory are always **free of charge**.
- If the <Gigaset.net> entry has been accidentally deleted from your handset directory, dial **1188#9** (the Gigaset.net directory phone number) and press the talk key . Or create a new directory entry with this number.

## Entering your own name

---

You are connected to the Gigaset.net directory:

- ▶ Select **Menu** → **Own information** and press **OK**.

Your Gigaset.net number and, where applicable, your currently entered name are displayed.

**Edit** Press the display key.

-  Enter/edit the name and press **OK**.

## Using the directory and lists

The options are:

- ◆ Directory
- ◆ Last number redial list
- ◆ SMS list
- ◆ Caller list

### Directory

- ▶ With the handset in idle status, open the directory by pressing the  key.

You can save 100 entries in the directory.

Length of an entry

Number: max. 32 digits

Name: max. 16 characters

#### Please note:

- You may also have to enter the phone number with the local area code for local calls when making VoIP calls to the fixed network (depending on the VoIP provider). You should therefore always save phone numbers in the directory with the area code.  
Alternatively, you can also use Web configurator to define an area code, which is automatically inserted in front of all numbers that are dialled without an area code for calls made via VoIP.
- You can assign a number from the directory to a key for speed dialling.

### Storing a number in the directory

 → **Menu** → New Entry



Enter number and press **OK**.  
If you add a star (\*) at the end of the number, then the number will always be dialled via the non-standard connection (page 26).



Enter the name and press **OK**.

### Assigning a key

**Menu** → Shortcut

Assign the current entry for quick dial to 0 or one of the keys from 2 to 9.

To dial the number, press and hold the appropriate quick dial key.

If there is a star (\*) at the end of the assigned number in the directory, then the number will be dialled via the non-standard connection; otherwise the standard connection that has been set will always be used (page 26).

### Managing directory entries

You can use the directory menu to, e.g.:

- ◆ Change or delete entries or send them to another of the base station's handsets
- ◆ Delete the directory or send it to another handset
- ▶ Select a directory entry and press **Menu** to open the menu.

For additional information, please see the full user guide for your Gigaset C450 IP on the Internet at [www.siemens.com/gigaset](http://www.siemens.com/gigaset).

### Last number redial list

The last number redial list contains the ten numbers last dialled with the handset.

- ▶ **Briefly** press the talk key  to open the last number redial list.

## Opening lists with the message key

---

You can use the message key  to open the following lists:

- ◆ SMS list
- ◆ Network mailbox  
If your network provider supports this function and the network mailbox is configured for fast access via key 1 (page 15).
- ◆ Calls list (precondition: Calling Line Identification enabled)  
The numbers of the last 30 incoming calls are saved. Multiple calls from the same number are all saved.

An advisory tone sounds as soon as a **new message** arrives in a list. The message key  flashes. A message appears in the display.

If you press the flashing  key, you will see all the lists that contain new messages. If only one list contains new messages, this will be opened automatically.

### Please note:

If calls are saved in the network answering machine you will receive a message if the appropriate settings have been made (see the network mailbox instructions of your network provider).

## Opening list

---



 → If necessary, select list

 Select entry.

For additional information on the lists, please see the full user guide for your Gigaset C460 IP (page 5).

## Dialling with directory/list

---

- ▶ Open directory/list.
- ▶ Select entry with .
- ▶ Briefly press/press and hold the talk key  (page 17).

### Please note:

You can only dial IP addresses via VoIP.

## SMS (text messages)

Your unit is supplied ready for you to send SMS messages immediately.

When an SMS is sent, the base station automatically establishes a connection via the fixed network.

### Requirements:

- ◆ Calling Line Identification (CLIP) has been enabled for your telephone connection.
- ◆ Your network provider supports SMS in the fixed network (information on this can be obtained from your network provider).
- ◆ You are registered with your service provider to send and receive SMS.

#### Please note:

When you call up the SMS menu for the first time, you are automatically registered with accessible SMS centres whose number you have entered. You can then receive SMS from these SMS centres.

You can enter further SMS centres and register with them with the help of the registration wizard. To find out how to do this, please read the full user guide for your Gigaset C460 IP (page 5).

## Writing/sending/saving SMS

An SMS may contain up to 160 characters.

**Menu** → **SMS** → **Write Message**



Write an SMS.

**Menu** **Send Text**

Select and press **OK**.



Enter the number with dialling code (including your local area code) from the directory or key it in manually, and press **OK**.  
For SMS to an SMS mailbox: put the mailbox ID at the end of the number.  
The SMS is sent.

Or:

**Menu** → **Save Text**

Select and press **OK**.

The SMS is saved in the draft message list. You can later edit and send it.

Opening the draft message list: **Menu** → **SMS** → **Outgoing**.

#### Please note:

If you are interrupted by an external call whilst writing the SMS, it is automatically saved in the draft message list.

## Receiving/reading SMS

All received SMS messages are saved in the message list. Linked SMS messages are divided into individual SMS messages with a maximum of 153 characters, and saved as such in the incoming message list.

New SMS messages are signalled on all Gigaset C46 handsets by a message in the display, the flashing message key and an advisory tone.

### Reading a text message

- ▶ Open the incoming message list with the message key (page 22) or via **Menu** → **SMS** → **Incoming 01+05**.
- ▶ Select **SMS**
- ▶ Select **Menu** → **Read SMS** and press **OK**.

## Managing SMS lists

You can use the incoming message and draft message lists to, e.g.:

- ◆ Delete individual SMS or the entire list
- ◆ Forward or reply to an SMS
- ▶ Select SMS and press **Menu** to open the menu.

**For additional information, please see the full user guide for your Gigaset C450 IP on the Internet at [www.siemens.com/gigaset](http://www.siemens.com/gigaset).**

## Setting handset/base station

---

The handset and base station are preset, but you can change these settings to suit your individual requirements. You will find the relevant functions in the submenus **Menu** → **Settings** and **Menu** → **Audio Settings** (page 14).



The base station settings are carried out using a registered Gigaset C46 handset.

## Adjusting the loudspeaker volume

---

You can set the loudspeaker volume for handsfree talking to five different levels and the earpiece volume to three different levels. You can only adjust the loudspeaker volume during a call.

You are conducting an external call.

-  Press the control key.
-  Adjust the volume and press **OK**.

### Please note:

The handsfree volume can only be adjusted when this function is set.

If  is assigned a different function, e.g. toggling:

**Menu** Open menu.

**Volume** Select and press **OK**.

Make settings (see above).

## Setting the ringer volume

---

The ringer volume is the same for all types of ring.

**Menu** → **Audio Settings** → **Ringer Volume**

Or in idle status:

 Press **briefly**.

Then:

 Adjust the volume and press **OK**.

 Press and **hold** (idle status).

## Activating/deactivating the ringer tone

---

You can turn off the ringer tone on your handset before you take a call or while the phone is in idle status. You can take a call as long as it is displayed on the screen.

### Deactivating the ringer tone

\*△ Press the star key **and hold** until the  icon appears in the display.

### Re-activating the ringer tone

\*△ Press and **hold** the star key in idle status.

## Activating/deactivating advisory tones

---

**Menu** → **Audio Settings** → **Advisory Tones**  
Select and press **OK** (✓ = on).

All advisory tones are activated or deactivated.

## Using the handset as an alarm clock

---

### Activating/deactivating the alarm clock

---

**Menu** → Alarm Clock → Activation  
(✓ = on)

After you activate the alarm clock, the menu for setting the wake up time opens automatically (page 25).

### Setting the wake up time

---

**Menu** → Alarm Clock → Wake up time

- ▶ Enter the wake up time in hours and minutes, then press **OK**.

### When the alarm clock rings...

---

#### Alarm repeat after 5 minutes

**Snooze** Press the display key or any key.

If you press **Snooze** three times the alarm clock switches off for 24 hours.

#### Switching off the alarm clock for 24 hours

**Off** Press the display key.

## Changing the base station system PIN

---

You can change the base station's 4-digit default system PIN ("0000") to a 4-digit PIN known only to yourself.

**Menu** → Settings → Base → System PIN



Enter current system PIN and press **OK**.



Enter your new system PIN and press **OK**.



Now re-enter the new system PIN and press **OK**.

For security reasons, "\*\*\*\*" is displayed instead of the numbers entered.



Press and **hold** (idle status).

## Restoring the handset default settings

---

Each individual handset setting is reset, in particular the language, display, volume, ringer tone, advisory tones and alarm clock settings (page 24).

The last number redial list is cleared.

Entries in the directory, the date and time, the calls list and the handset's registration to the base station will be retained.

**Menu** → Settings → Handset  
→ Reset Handset



Press the display key to confirm.



Press and **hold** (idle status).

Cancel the reset with .

## Restoring the base station to factory settings

---

### Resetting the base station via the menu

---

Each individual setting is reset, in particular:

- ◆ VoIP settings such as VoIP provider and account data and DTMF settings
- ◆ Settings for the local network (page 26)
- ◆ Default connection (page 26)
- ◆ The names of the handsets
- ◆ SMS settings (e.g. SMS centres)
- ◆ PABX connection settings.

SMS lists and calls lists are deleted.

The date and time and the system PIN are retained. The handsets are still registered.

**Menu** → **Settings** → **Base** → **Base Reset**

**OK** Press the display key to confirm.

### Resetting the base station using a key on the base station

---

As with resetting the base station via the menu, all individual settings are reset. The system PIN will also be reset to "0000" and all handsets registered above and beyond the delivery scope are deregistered.

#### Please note:

For information on how to reregister the handset after resetting it, where applicable, please see the full user guide for your Gigaset C450 IP on the Internet.

- ▶ Remove the cable connections from the base station to the router and fixed network.
- ▶ Remove the base station mains unit from the socket.
- ▶ Press and hold the registration/paging key (page 1).
- ▶ Plug the mains unit back into the power socket.
- ▶ Keep holding the registration/paging key (at least 10 sec.).
- ▶ Release the registration/paging key. The base station has now been reset.

## Setting the default connection

---

You can make settings according to whether you want to make calls via VoIP or fixed network by default.

**Menu** → **Settings** → **Base** → **Telephony**  
→ **Default Line Type**

IP / fixed line

Select and press **OK** (✓ = on).

**For additional information on the phone and VoIP settings, please see the full user guide for your Gigaset C450 IP on the Internet at [www.siemens.com/gigaset](http://www.siemens.com/gigaset).**

## Assigning the phone a fixed IP address

---

If DHCP is disabled on the router, you must assign the phone a fixed IP address and generally enter the router as the gateway to the Internet and DNS server.

**Menu** → **Settings** → **Base** → **Local Network**



Enter the system PIN and press **OK**.

dynamic IP address (✓ = on)

Select and press **OK**.

IP Address Select and press **OK**.



Enter the IP address and press **OK**. 192.168.2.2 has been preset by default.

### Subnet Mask

Select and press **OK**.



If necessary, enter the subnet mask and press **OK**.  
The default setting is:  
255.255.255.000.

### DNS Server



Enter the IP address of your preferred DNS server and press **OK**. This is generally the local IP address of your router. 192.168.2.1 has been preset.

### Default Gateway

Select and press **OK**.



Enter the IP address gateway to the Internet and press **OK**. This is generally the local IP address of your router. 192.168.2.1 has been preset.

**For more information on the phone and VoIP settings, please see the full user guide for your Gigaset C450 IP on the Internet.**

## Web configurator

The Web configurator is the Web interface for your handset. It allows you to make the settings for your phone's base station via your PC's Web browser.

### Requirements:

- ◆ A standard Web browser is installed on the PC, e.g. Internet Explorer version 6.0 or higher, or Firefox version 1.0.4 or higher.
- ◆ The phone and PC are connected to each other via a router or a switch.

## Connecting your PC to the Web configurator

- ▶ Launch the Web browser on your PC.  
**Precondition:** The Firewall settings on your PC allow the PC and the phone to communicate with each other.
- ▶ Enter the phone's IP address in the address field of the Web browser, e.g. http://192.168.1.10.  
You can check the phone's current IP address on the handset:  
**Menu** → **Settings** → **Base**  
→ **Local Network** → (enter System PIN)  
→ **IP Address**.
- ▶ Press the return key.

A connection is established to the phone's Web configurator.

## De-registering

In the menu bar at the top right of every Web page in the Web configurator, you will see the command **Log Off**. Click on **Log Off** to de-register from the Web configurator.

## Web configurator functions

### Menu tree

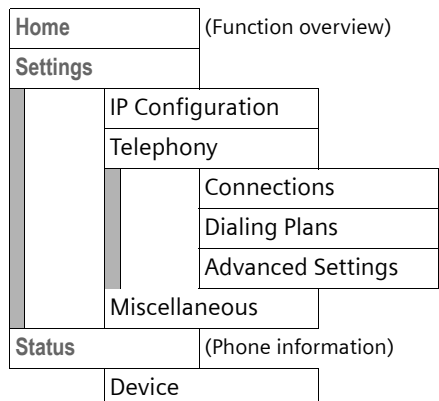

### Settings

With the Web configurator on your phone you have the following options:

#### ◆ IP Configuration

Configure your phone access to the local network (IP address, gateway to the Internet).

You must enter the gateway and DNS server via the Web configurator, in particular when assigning your phone a static IP address. This is generally your router.

#### ◆ Telephony → Connections

Configure your phone for VoIP.

Download your VoIP provider's general access data from the Internet to your phone or enter the data yourself.

Enter the personal access data of your VoIP account (VoIP phone number) with this VoIP provider.

Activate/deactivate this VoIP phone number as required.

The phone registers with the VoIP server using the activated VoIP phone number and can be reached at this number.

#### **Please note:**

For Gigaset C450IP base stations manufactured before June 2006, "VoIP" is displayed instead of "Connections" after a firmware update.

#### ◆ Telephony → Dialing Plans

You can activate and deactivate the following dialling plans.

- In VoIP calls, all numbers that do not begin with 0 are automatically assigned an area code. Define this area code.
- The saved emergency numbers are always dialled via the fixed network. The saved emergency numbers are displayed. You can enter a phone number of your own.

#### ◆ Telephony → Advanced Settings

- Specify port numbers that the phone should use for VoIP telephony.
- For VoIP, specify how DTMF signals are to be transferred and/or converted: either in voice packets or in SIP info packets. DTMF signalling is required for playing and controlling some network mailboxes, for example. Ask your VoIP provider which type of DTMF signalling is supported.

#### ◆ Miscellaneous

Specify whether you want to be informed about new firmware versions on the Internet.

For the following firmware update, you can specify the server/PC by which the update should be carried out, and you can also load new firmware to your phone.

To diagnose VoIP connection problems, display the VoIP status codes on your handset.

**You will find information on the Web configurator in the full user guide for your Gigaset C450 IP on the Internet at [www.siemens.com/gigaset](http://www.siemens.com/gigaset).**

## Appendix

---

### Care

---

- ▶ Wipe the base station and handset with a **damp** cloth (do not use solvent) or an antistatic cloth.

**Never** use a dry cloth. This can cause static.

### Contact with liquid

---

If the handset has come into contact with liquid:

- ▶ **Switch the handset off and remove the batteries immediately.**
- ▶ Allow the liquid to drain from the handset.
- ▶ Pat all parts dry, then place the handset with the battery compartment open and the keypad facing down in a dry, warm place **for at least 72 hours** (not in a microwave, oven etc.).
- ▶ **Do not switch on the handset again until it is completely dry.**

When it has fully dried out, you will normally be able to use it again.

### Questions and answers

---

If you have any queries about the use of your phone, you can contact us any time at

[www.siemens.com/gigasetcustomercare](http://www.siemens.com/gigasetcustomercare). You can also find information on common problems and possible solutions in the full user guide.

## Service (Customer Care)

---

We offer you support that is fast and tailored to your specific needs!

Our Online Support on the Internet can be reached any time from anywhere.

<http://www.siemens.com/gigasetcustomercare>

It provides you with 24/7 support for all our products. It also provides a list of FAQs and answers plus user guides and current software updates (if available for the product) for you to download.

You will also find frequently asked questions and answers in the detailed user guide on the enclosed CD or in the Internet at <http://www.siemens.com/gigaset>.

For personal advice on our range of products and assistance with repairs or guarantee/warranty claims you can contact us on:

**UK helpdesk: 0 84 53 67 08 12.**

Please have your proof of purchase ready when calling with regard to guarantee/warranty claims.

Replacement or repair services are not offered in countries where our product is not sold by authorised dealers.

Please address any questions about DSL access and VoIP access to the respective service provider.

## Approval

---

### Authorisation

This device is intended for analogue phone lines in the UK.

Voice over IP telephony is possible via the LAN interface if an additional modem has been connected.

Country-specific requirements have been taken into consideration.

We, Siemens Home and Office Communication Devices GmbH & Co. KG, declare that this device meets the essential requirements and other relevant regulations laid down in Directive 1999/5/EC.

A copy of the 1999/5/EC Declaration of Conformity is available at this Internet address:

<http://www.siemens.com/gigasetdocs>.

CE 0682

## Guarantee Certificate United Kingdom

---

Without prejudice to any claim the user (customer) may have in relation to the dealer or retailer, the customer shall be granted a manufacturer's Guarantee under the conditions set out below:

◆ In the case of new devices and their components exhibiting defects resulting from manufacturing and/or material faults within 24 months of purchase, Siemens shall, at its own option and free of charge, either replace the device with another device reflecting the current state of the art, or repair the said device. In respect of parts subject to wear and tear (including but not limited to, batteries, keypads, casing), this warranty shall be valid for six months from the date of purchase.

- ◆ This Guarantee shall be invalid if the device defect is attributable to improper treatment and/or failure to comply with information contained in the user guides.
- ◆ This Guarantee shall not apply to or extend to services performed by the authorised dealer or the customer themselves (e. g. installation, configuration, software downloads). User guides and any software supplied on a separate data medium shall be excluded from the Guarantee.
- ◆ The purchase receipt, together with the date of purchase, shall be required as evidence for invoking the Guarantee. Claims under the Guarantee must be submitted within two months of the Guarantee default becoming evident.
- ◆ Ownership of devices or components replaced by and returned to Siemens shall vest in Siemens.
- ◆ This Guarantee shall apply to new devices purchased in the European Union. For Products sold in the United Kingdom the Guarantee is issued by: Siemens Home and Office Communication Devices GmbH & Co. KG, Schlavenhorst 66, D-46395 Bocholt, Germany.
- ◆ Any other claims resulting out of or in connection with the device shall be excluded from this Guarantee. Nothing in this Guarantee shall attempt to limit or exclude a Customers Statutory Rights, nor the manufacturer's liability for death or personal injury resulting from its negligence.
- ◆ The duration of the Guarantee shall not be extended by services rendered under the terms of the Guarantee.
- ◆ Insofar as no Guarantee default exists, Siemens reserves the right to charge the customer for replacement or repair.
- ◆ The above provisions does not imply a change in the burden of proof to the detriment of the customer.

To invoke this Guarantee, please contact the Siemens telephone service. The rele-

vant number is to be found in the accompanying user guide.

## Specifications

### Recommended rechargeable batteries

(Valid at the time of going to press)

Nickel-metal-hydride (NiMH):

- ◆ Sanyo Twicell 650
- ◆ Sanyo Twicell 700
- ◆ Sanyo NiMH 800
- ◆ Panasonic 700 mAh "for DECT"
- ◆ GP 550mAh
- ◆ GP 700mAh
- ◆ GP 850mAh
- ◆ Yuasa Technology AAA Phone 600
- ◆ Yuasa Technology AAA Phone 700
- ◆ Yuasa Technology AAA 800
- ◆ VARTA Phone Power AAA 700mAh

The handset is supplied with two recommended batteries.

### Handset operating times/charging times

The following information relates to batteries with a capacity of 650 mAh.

Standby time	around 125 hours (5 days)
Talktime	around 13 hours
Charging time	around 7.5 hours

The operating and charging times apply only when using the recommended batteries.

### Base station power consumption

Depending on current status, around 2.5 W.

## General specifications

Interfaces	Fixed network, Ethernet
DECT standard	is supported
GAP standard	is supported
No. of channels	60 duplex channels
Radio frequency range	1880–1900 MHz
Duplex method	Time multiplex, 10 ms frame length
Channel grid	1728 kHz
Bit rate	1152 kbit/s
Modulation	GFSK
Language code	32 kbit/s
Transmission power	10 mW, average power per channel
Range	up to 300 m outdoors, up to 50 m indoors
Base station power supply	230 V ~/50 Hz
Environmental conditions for operation	+5 °C to +45 °C; 20% to 75% relative humidity
Dialling mode	DTMF (touch tone dialling)/DP (dial pulsing)
Flash time	250 ms
Codecs	G711, G726, G729AB with VAD/CNG
Quality of Service	TOS, DiffServ
Protocols	DECT, SIP, RTP, DHCP, NAT Traversal (STUN)
Base station dimensions	105 x 132 x 46 mm (L x W x D)
Dimensions, handset	141 x 53 x 31 mm (L x W x H)
Base station weight	130 g
Weight of handset with battery	116 g

## Gigaset C460 IP – Free software

Your Gigaset C460 IP's firmware contains, amongst other things, free software that is licensed under the GNU Lesser General Public License. This free software was developed by a third party and is protected by copyright. You will find the licence text in its original English version on the pages that follow.

The software is provided free of charge. You are authorised to use this free software in accordance with the above-mentioned licence conditions. In the event of contradictions between these licence conditions and the licence conditions that apply for the software according to Siemens Home and Office Communication Devices GmbH & Co. KG, the above-mentioned licence conditions shall take precedence for the free software.

The GNU Lesser General Public License (LGPL) is supplied with this product. You can also download the licence conditions from the Internet:

- ◆ The **LGPL** is available on the Internet at: <http://www.gnu.org/copyleft/lesser.html>
- ◆ The **source text, including copyright notices for free software**, is currently available on the Internet at: <http://www.siemens.com/developer/c455ip>

For more information and Internet links to the source text of the free software, see the Online Support pages on the Internet at:

[www.siemens.com/gigasetcustomer-care](http://www.siemens.com/gigasetcustomer-care)

If it is not already supplied with the product, you can request the source text, including copyright notices, from Siemens Home and Office Communication Devices GmbH & Co. KG. There is a charge to cover the cost of copying and postage. Please submit this request by Email or fax to the following address or fax number within 3 years of purchasing this product. Please state the exact device type plus the version number of the installed device software.

Small Parts Dispatch Com Bocholt

Email: [kleinteileversand.com@siemens.com](mailto:kleinteileversand.com@siemens.com)

Fax: +49 2871 913029

Use of the free software contained in this product extending beyond the program sequence intended by Siemens Home and Office Communication Devices GmbH & Co. is at the user's own risk – i.e. there shall be no claims for liability for defects against Siemens Home and Office Communication Devices GmbH & Co. KG. The GNU Lesser General Public License contains notes regarding the author's liability for defects or other proprietors of the free software.

You shall have no right to assert a claim against Siemens Home and Office Communication Devices GmbH & Co. KG based on liability for defects, if a defect in the product is or could be due to changes you have made to the programs or their configuration. Furthermore, you shall have no right to assert a claim against Siemens Home and Office Communication Devices GmbH & Co. KG based on liability for defects if the free software violates the copyright of third parties.

Siemens Home and Office Communication Devices GmbH & Co. KG shall not provide technical support for the software, including the free software included within it, if it has been changed.

## GNU LESSER GENERAL PUBLIC LICENSE

---

Version 2.1, February 1999

Copyright (C) 1991, 1999 Free Software Foundation, Inc., 59 Temple Place, Suite 330, Boston, MA 02111-1307 USA

Everyone is permitted to copy and distribute verbatim copies of this license document, but changing it is not allowed.

[This is the first released version of the Lesser GPL. It also counts as the successor of the GNU Library Public License, version 2, hence the version number 2.1.]

### Preamble

The licenses for most software are designed to take away your freedom to share and change it. By contrast, the GNU General Public Licenses are intended to guarantee your freedom to share and change free software--to make sure the software is free for all its users.

This license, the Lesser General Public License, applies to some specially designated software packages--typically libraries--of the Free Software Foundation and other authors who decide to use it. You can use it too, but we suggest you first think carefully about whether this license or the ordinary General Public License is the better strategy to use in any particular case, based on the explanations below.

When we speak of free software, we are referring to freedom of use, not price. Our General Public Licenses are designed to make sure that you have the freedom to distribute copies of free software (and charge for this service if you wish); that you receive source code or can get it if you want it; that you can change the software and use pieces of it in new free programs; and that you are informed that you can do these things.

To protect your rights, we need to make restrictions that forbid distributors to deny you these rights or to ask you to surrender these rights. These restrictions translate to certain responsibilities for you if you distribute copies of the library or if you modify it.

For example, if you distribute copies of the library, whether gratis or for a fee, you must give the recipients all the rights that we gave you. You must make sure that they, too, receive or can get the source code. If you link other code with the library, you must provide complete object files to the recipients, so that they can relink them with the library after making changes to the library and recompiling it. And you must show them these terms so they know their rights.

We protect your rights with a two-step method: (1) we copyright the library, and (2) we offer you this license, which gives you legal permission to copy, distribute and/or modify the library.

To protect each distributor, we want to make it very clear that there is no warranty for the free library. Also, if the library is modified by someone else and passed on, the recipients should know that what they have is not the original version, so that the original author's reputation will not be affected by problems that might be introduced by others.

Finally, software patents pose a constant threat to the existence of any free program. We wish to make sure that a company cannot effectively restrict the users of a free program by obtaining a restrictive license from a patent holder. Therefore, we insist that any patent license obtained for a version of the library must be consistent with the full freedom of use specified in this license.

Most GNU software, including some libraries, is covered by the ordinary GNU General Public License. This license, the GNU Lesser General Public License, applies to certain designated libraries, and is quite different from the ordinary General Public License. We use this license for certain libraries in order to permit linking those libraries into non-free programs.

When a program is linked with a library, whether statically or using a shared library, the combination of the two is legally speaking a combined work, a derivative of the original library. The ordinary General Public License therefore permits such linking only if the entire combination fits its criteria of freedom. The Lesser General Public License permits more lax criteria for linking other code with the library. We call this license the "Lesser" General Public License because it does Less to protect the user's freedom than the ordinary General Public License. It also provides other free software developers Less of an advantage over competing non-free programs. These disadvantages are the reason we use the ordinary General Public License for many libraries. However, the Lesser license provides advantages in certain special circumstances.

For example, on rare occasions, there may be a special need to encourage the widest possible use of a certain library, so that it becomes a de-facto standard. To achieve this, non-free programs must be allowed to use the library. A more frequent case is that a free library does the same job as widely used non-free libraries. In this case, there is little to gain by limiting the

free library to free software only, so we use the Lesser General Public License.

In other cases, permission to use a particular library in non-free programs enables a greater number of people to use a large body of free software. For example, permission to use the GNU C Library in non-free programs enables many more people to use the whole GNU operating system, as well as its variant, the GNU/Linux operating system.

Although the Lesser General Public License is less protective of the users' freedom, it does ensure that the user of a program that is linked with the Library has the freedom and the wherewithal to run that program using a modified version of the Library.

The precise terms and conditions for copying, distribution and modification follow. Pay close attention to the difference between a "work based on the library" and a "work that uses the library". The former contains code derived from the library, whereas the latter must be combined with the library in order to run.

### **GNU LESSER GENERAL PUBLIC LICENSE TERMS AND CONDITIONS FOR COPYING, DISTRIBUTION AND MODIFICATION**

**0.** This License Agreement applies to any software library or other program which contains a notice placed by the copyright holder or other authorized party saying it may be distributed under the terms of this Lesser General Public License (also called "this License"). Each licensee is addressed as "you".

A "library" means a collection of software functions and/or data prepared so as to be conveniently linked with application programs (which use some of those functions and data) to form executables.

The "Library", below, refers to any such software library or work which has been distributed under these terms. A "work based on the Library" means either the Library or any derivative work under copyright law: that is to say, a work containing the Library or a portion of it, either verbatim or with modifications and/or translated straightforwardly into another language. (Hereinafter, translation is included without limitation in the term "modification".) "Source code" for a work means the preferred form of the work for making modifications to it. For a library, complete source code means all the source code for all modules it contains, plus any associated interface definition files, plus the scripts used to control compilation and installation of the library.

Activities other than copying, distribution and modification are not covered by this License; they are outside its scope. The act of running a program using the Library is not restricted, and output from such a program is covered only if its contents constitute a work based on the Library (independent of the use of the Library in a tool for writing it). Whether that is true depends on what the Library does and what the program that uses the Library does.

**1.** You may copy and distribute verbatim copies of the Library's complete source code as you receive it, in any medium, provided that you conspicuously and appropriately publish on each copy an appropriate copyright notice and disclaimer of warranty; keep intact all the notices that refer to this License and to the absence of any warranty; and distribute a copy of this License along with the Library.

You may charge a fee for the physical act of transferring a copy, and you may at your option offer warranty protection in exchange for a fee.

**2.** You may modify your copy or copies of the Library or any portion of it, thus forming a work based on the Library, and copy and distribute such modifications or work under the terms of Section 1 above, provided that you also meet all of these conditions:

a) The modified work must itself be a software library.

b) You must cause the files modified to carry prominent notices stating that you changed the files and the date of any change.

c) You must cause the whole of the work to be licensed at no charge to all third parties under the terms of this License.

d) If a facility in the modified Library refers to a function or a table of data to be supplied by an application program that uses the facility, other than as an argument passed when the facility is invoked, then you must make a good faith effort to ensure that, in the event an application does not supply such function or table, the facility still operates, and performs whatever part of its purpose remains meaningful.

(For example, a function in a library to compute square roots has a purpose that is entirely well-defined independent of the application. Therefore, Subsection 2d requires that any application-supplied function or table used by this function must be optional: if the application does not supply it, the square root function must still compute square roots.)

These requirements apply to the modified work as a whole. If identifiable sections of that work are not derived from the Library, and can be reasonably considered independent and sepa-

rate works in themselves, then this License, and its terms, do not apply to those sections when you distribute them as separate works. But when you distribute the same sections as part of a whole which is a work based on the Library, the distribution of the whole must be on the terms of this License, whose permissions for other licensees extend to the entire whole, and thus to each and every part regardless of who wrote it.

Thus, it is not the intent of this section to claim rights or contest your rights to work written entirely by you; rather, the intent is to exercise the right to control the distribution of derivative or collective works based on the Library.

In addition, mere aggregation of another work not based on the Library with the Library (or with a work based on the Library) on a volume of a storage or distribution medium does not bring the other work under the scope of this License.

**3.** You may opt to apply the terms of the ordinary GNU General Public License instead of this License to a given copy of the Library. To do this, you must alter all the notices that refer to this License, so that they refer to the ordinary GNU General Public License, version 2, instead of to this License. (If a newer version than version 2 of the ordinary GNU General Public License has appeared, then you can specify that version instead if you wish.) Do not make any other change in these notices.

Once this change is made in a given copy, it is irreversible for that copy, so the ordinary GNU General Public License applies to all subsequent copies and derivative works made from that copy.

This option is useful when you wish to copy part of the code of the Library into a program that is not a library.

**4.** You may copy and distribute the Library (or a portion or derivative of it, under Section 2) in object code or executable form under the terms of Sections 1 and 2 above provided that you accompany it with the complete corresponding machine-readable source code, which must be distributed under the terms of Sections 1 and 2 above on a medium customarily used for software interchange.

If distribution of object code is made by offering access to copy from a designated place, then offering equivalent access to copy the source code from the same place satisfies the requirement to distribute the source code, even though third parties are not compelled to copy the source along with the object code.

**5.** A program that contains no derivative of any portion of the Library, but is designed to work with the Library by being compiled or linked with it, is called a "work that uses the Library". Such a work, in isolation, is not a derivative work of the Library, and therefore falls outside the scope of this License.

However, linking a "work that uses the Library" with the Library creates an executable that is a derivative of the Library (because it contains portions of the Library), rather than a "work that uses the library". The executable is therefore covered by this License.

Section 6 states terms for distribution of such executables.

When a "work that uses the Library" uses material from a header file that is part of the Library, the object code for the work may be a derivative work of the Library even though the source code is not.

Whether this is true is especially significant if the work can be linked without the Library, or if the work is itself a library. The threshold for this to be true is not precisely defined by law.

If such an object file uses only numerical parameters, data structure layouts and accessors, and small macros and small inline functions (ten lines or less in length), then the use of the object file is unrestricted, regardless of whether it is legally a derivative work. (Executables containing this object code plus portions of the Library will still fall under Section 6.)

Otherwise, if the work is a derivative of the Library, you may distribute the object code for the work under the terms of Section 6.

Any executables containing that work also fall under Section 6, whether or not they are linked directly with the Library itself.

**6.** As an exception to the Sections above, you may also combine or link a "work that uses the Library" with the Library to produce a work containing portions of the Library, and distribute that work under terms of your choice, provided that the terms permit modification of the work for the customer's own use and reverse engineering for debugging such modifications.

You must give prominent notice with each copy of the work that the Library is used in it and that the Library and its use are covered by this License. You must supply a copy of this License. If the work during execution displays copyright notices, you must include the copyright notice for the Library among them, as well as a reference directing the user to the copy of this License. Also, you must do one of these things:

- a) Accompany the work with the complete corresponding machine-readable source code for

## Appendix

the Library including whatever changes were used in the work (which must be distributed under Sections 1 and 2 above); and, if the work is an executable linked with the Library, with the complete machine-readable "work that uses the Library", as object code and/or source code, so that the user can modify the Library and then relink to produce a modified executable containing the modified Library. (It is understood that the user who changes the contents of definitions files in the Library will not necessarily be able to recompile the application to use the modified definitions.)

b) Use a suitable shared library mechanism for linking with the Library. A suitable mechanism is one that (1) uses at run time a copy of the library already present on the user's computer system, rather than copying library functions into the executable, and (2) will operate properly with a modified version of the library, if the user installs one, as long as the modified version is interface-compatible with the version that the work was made with.

c) Accompany the work with a written offer, valid for at least three years, to give the same user the materials specified in Subsection 6a, above, for a charge no more than the cost of performing this distribution.

d) If distribution of the work is made by offering access to copy from a designated place, offer equivalent access to copy the above specified materials from the same place.

e) Verify that the user has already received a copy of these materials or that you have already sent this user a copy.

For an executable, the required form of the "work that uses the Library" must include any data and utility programs needed for reproducing the executable from it. However, as a special exception, the materials to be distributed need not include anything that is normally distributed (in either source or binary form) with the major components (compiler, kernel, and so on) of the operating system on which the executable runs, unless that component itself accompanies the executable.

It may happen that this requirement contradicts the license restrictions of other proprietary libraries that do not normally accompany the operating system. Such a contradiction means you cannot use both them and the Library together in an executable that you distribute.

7. You may place library facilities that are a work based on the Library side-by-side in a single library together with other library facilities not covered by this License, and distribute such a combined library, provided that the separate

distribution of the work based on the Library and of the other library facilities is otherwise permitted, and provided that you do these two things:

a) Accompany the combined library with a copy of the same work based on the Library, uncombined with any other library facilities. This must be distributed under the terms of the Sections above.

b) Give prominent notice with the combined library of the fact that part of it is a work based on the Library, and explaining where to find the accompanying uncombined form of the same work.

8. You may not copy, modify, sublicense, link with, or distribute the Library except as expressly provided under this License. Any attempt otherwise to copy, modify, sublicense, link with, or distribute the Library is void, and will automatically terminate your rights under this License. However, parties who have received copies, or rights, from you under this License will not have their licenses terminated so long as such parties remain in full compliance.

9. You are not required to accept this License, since you have not signed it. However, nothing else grants you permission to modify or distribute the Library or its derivative works. These actions are prohibited by law if you do not accept this License. Therefore, by modifying or distributing the Library (or any work based on the Library), you indicate your acceptance of this License to do so, and all its terms and conditions for copying, distributing or modifying the Library or works based on it.

10. Each time you redistribute the Library (or any work based on the Library), the recipient automatically receives a license from the original licensor to copy, distribute, link with or modify the Library subject to these terms and conditions. You may not impose any further restrictions on the recipients' exercise of the rights granted herein.

You are not responsible for enforcing compliance by third parties with this License.

11. If, as a consequence of a court judgment or allegation of patent infringement or for any other reason (not limited to patent issues), conditions are imposed on you (whether by court order, agreement or otherwise) that contradict the conditions of this License, they do not excuse you from the conditions of this License. If you cannot distribute so as to satisfy simultaneously your obligations under this License and any other pertinent obligations, then as a consequence you may not distribute the Library at

all. For example, if a patent license would not permit royalty-free redistribution of the Library by all those who receive copies directly or indirectly through you, then the only way you could satisfy both it and this License would be to refrain entirely from distribution of the Library. If any portion of this section is held invalid or unenforceable under any particular circumstance, the balance of the section is intended to apply, and the section as a whole is intended to apply in other circumstances.

It is not the purpose of this section to induce you to infringe any patents or other property right claims or to contest validity of any such claims; this section has the sole purpose of protecting the integrity of the free software distribution system which is implemented by public license practices. Many people have made generous contributions to the wide range of software distributed through that system in reliance on consistent application of that system; it is up to the author/donor to decide if he or she is willing to distribute software through any other system and a licensee cannot impose that choice.

This section is intended to make thoroughly clear what is believed to be a consequence of the rest of this License.

**12.** If the distribution and/or use of the Library is restricted in certain countries either by patents or by copyrighted interfaces, the original copyright holder who places the Library under this License may add an explicit geographical distribution limitation excluding those countries, so that distribution is permitted only in or among countries not thus excluded. In such case, this License incorporates the limitation as if written in the body of this License.

**13.** The Free Software Foundation may publish revised and/or new versions of the Lesser General Public License from time to time. Such new versions will be similar in spirit to the present version, but may differ in detail to address new problems or concerns.

Each version is given a distinguishing version number. If the Library specifies a version number of this License which applies to it and "any later version", you have the option of following the terms and conditions either of that version or of any later version published by the Free Software Foundation. If the Library does not specify a license version number, you may choose any version ever published by the Free Software Foundation.

**14.** If you wish to incorporate parts of the Library into other free programs whose distribution conditions are incompatible with these,

write to the author to ask for permission. For software which is copyrighted by the Free Software Foundation, write to the Free Software Foundation; we sometimes make exceptions for this. Our decision will be guided by the two goals of preserving the free status of all derivatives of our free software and of promoting the sharing and reuse of software generally.

#### **NO WARRANTY**

**15.** BECAUSE THE LIBRARY IS LICENSED FREE OF CHARGE, THERE IS NO WARRANTY FOR THE LIBRARY, TO THE EXTENT PERMITTED BY APPLICABLE LAW.

EXCEPT WHEN OTHERWISE STATED IN WRITING THE COPYRIGHT HOLDERS AND/OR OTHER PARTIES PROVIDE THE LIBRARY "AS IS" WITHOUT WARRANTY OF ANY KIND, EITHER EXPRESSED OR IMPLIED, INCLUDING, BUT NOT LIMITED TO, THE IMPLIED WARRANTIES OF MERCHANTABILITY AND FITNESS FOR A PARTICULAR PURPOSE. THE ENTIRE RISK AS TO THE QUALITY AND PERFORMANCE OF THE LIBRARY IS WITH YOU. SHOULD THE LIBRARY PROVE DEFECTIVE, YOU ASSUME THE COST OF ALL NECESSARY SERVICING, REPAIR OR CORRECTION.

**16.** IN NO EVENT UNLESS REQUIRED BY APPLICABLE LAW OR AGREED TO IN WRITING WILL ANY COPYRIGHT HOLDER, OR ANY OTHER PARTY WHO MAY MODIFY AND/OR REDISTRIBUTE THE LIBRARY AS PERMITTED ABOVE, BE LIABLE TO YOU FOR DAMAGES, INCLUDING ANY GENERAL, SPECIAL, INCIDENTAL OR CONSEQUENTIAL DAMAGES ARISING OUT OF THE USE OR INABILITY TO USE THE LIBRARY (INCLUDING BUT NOT LIMITED TO LOSS OF DATA OR DATA BEING RENDERED INACCURATE OR LOSSES SUSTAINED BY YOU OR THIRD PARTIES OR A FAILURE OF THE LIBRARY TO OPERATE WITH ANY OTHER SOFTWARE), EVEN IF SUCH HOLDER OR OTHER PARTY HAS BEEN ADVISED OF THE POSSIBILITY OF SUCH DAMAGES.

#### **END OF TERMS AND CONDITIONS**

### How to Apply These Terms to Your New Libraries

If you develop a new library, and you want it to be of the greatest possible use to the public, we recommend making it free software that everyone can redistribute and change. You can do so by permitting redistribution under these terms (or, alternatively, under the terms of the ordinary General Public License).

To apply these terms, attach the following notices to the library. It is safest to attach them to the start of each source file to most effectively convey the exclusion of warranty; and each file should have at least the "copyright" line and a pointer to where the full notice is found.

<one line to give the library's name and a brief idea of what it does.>  
Copyright (C) <year> <name of author>  
This library is free software; you can redistribute it and/or modify it under the terms of the GNU Lesser General Public License as published by the Free Software Foundation; either version 2.1 of the License, or (at your option) any later version.  
This library is distributed in the hope that it will be useful, but WITHOUT ANY WARRANTY; without even the implied warranty of MERCHANTABILITY or FITNESS FOR A PARTICULAR PURPOSE. See the GNU Lesser General Public License for more details.

You should have received a copy of the GNU Lesser General Public License along with this library; if not, write to the Free Software Foundation, Inc., 59 Temple Place, Suite 330, Boston, MA 02111-1307 USA

Also add information on how to contact you by electronic and paper mail.

You should also get your employer (if you work as a programmer) or your school, if any, to sign a "copyright disclaimer" for the library, if necessary. Here is a sample; alter the names:

Yoyodyne, Inc., hereby disclaims all copyright interest in the library 'Frob' (a library for tweaking knobs) written by James Random Hacker. <signature of Ty Coon>, 1 April 1990  
Ty Coon, President of Vice

