

The Mathematics of Log-Based Dynamic Processors

Abstract

Dynamic Processors (compressors, expanders, gates, etc.) may be easily constructed from THAT Corporation Voltage-Controlled Amplifiers (VCAs) and RMS-Level Detectors. The detector is used to sense signal level and control the gain of the VCA to produce compression or expansion. Both feedback and feedforward configurations are possible.

Because these parts respond in logarithmic fashion, developing a mathematical description of

circuits using them often leads to murky equations which do little to clarify the circuit behavior. However, via an appropriate choice of units, the mathematics can often be drastically simplified, resulting in surprisingly simple algebraic equations to describe the circuit.

This application note describes the basis for this mathematical treatment, and offers insights into its application to circuit designs based on these log-responding components.

The Mathematics of Log-Based Dynamic Processors

A dynamic audio processor is a device which adjusts its gain to suit the requirements of the applied audio signal. Dynamic processors include compressors, expanders, noise gates, and similar devices. All share the characteristic that their signal gain is dependent on the input signal level in some fashion. A compressor reduces its gain as the input signal *increases*, while a gate reduces its gain as the input signal *decreases*. However, the basic concept of varying gain to suit the requirements of the signal remains unchanged.

At its most basic level, a dynamic processor consists of a level sensor, a control-voltage processor and a voltage-controlled amplifier (VCA). The level sensor produces a varying dc voltage representative of the signal level. The control-voltage processor conditions this dc voltage, enabling it to control

the VCA gain as required. The VCA then adjusts the signal gain based on the control voltage.

There are two major configurations for dynamic audio processors: *feedback* and *feedforward*. Simplified block diagrams of these two configurations are shown in Figures 1 and 2. The amplifier with gain G is the control-voltage processor, reduced to its simplest form.

Many of the most popular dynamic audio processors have been constructed using THAT Corporation VCAs and THAT 2252 rms-level detectors. The gain of a THAT215X or THAT218X VCA, and of the VCA portion of a THAT4301 is exponentially dependent on its control signal. Conceptually this is very simple: the VCA gain in *decibels* is directly proportional to the control voltage applied. How-

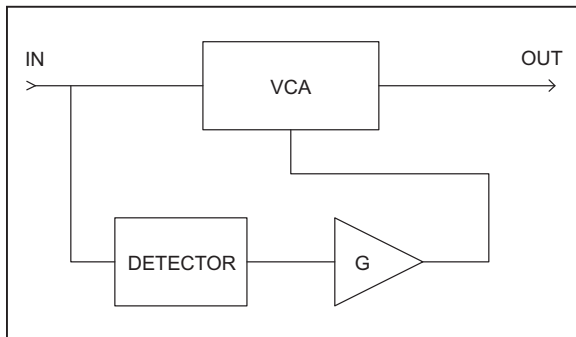

Figure 1. Block Diagram of a Feedforward Processor

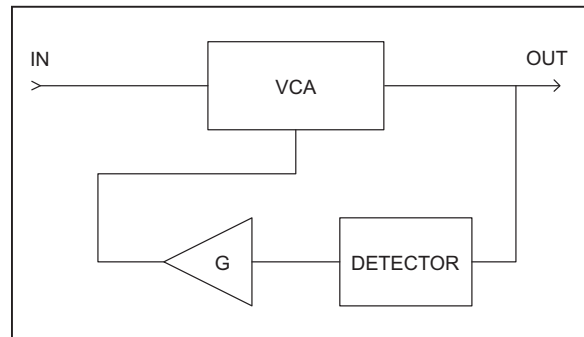

Figure 2. Block Diagram of a Feedback Processor

ever, when expressed mathematically, it appears more formidable:

$$A_V = e^{\frac{E_C}{2V_T}}, \quad \text{Eq. 1}$$

where A_V is the gain of the VCA (in volts/volt), E_C is the applied control voltage, and V_T is the thermal voltage (kT/q) from the diode equation.

The THAT 2252 rms-level detector and the rms-level detector in the THAT 4301 share this simple-but-complex characteristic. Their output signals are directly proportional to the decibel level of their input signals. Mathematically, this is further complicated by the time response of the detector, but if one only considers the steady-state condition, the math is as follows:

$$V_{OUT} = 2V_T \ln(V_{irms}) = 0.052 \ln(V_{irms}), \quad \text{Eq. 2}$$

where V_{OUT} is the output voltage of the detector, and V_{irms} is the rms value of its input signal.

It is possible to write an equation which describes the action of the simple dynamic processors shown in Figures 1 and 2 using the logs and exponentials of equations 1 and 2 above. However, this does not lend itself to illuminating the design process. The resulting equation is difficult to solve in closed form, and, at least to this author, does not offer insight into the action of the processor.

Making the Math Simple

However, it is possible to greatly simplify the math while adding to the meaning which it conveys. Consider that, in audio products, it is the *decibel level* of the signal which is most important, most relevant to our perception. By thinking about all the signal voltages in the circuit in terms of decibels, the mathematics can be reduced to simple algebra!

Consider the following equation:

$$A_{dB} = -166.7 E_C. \quad \text{Eq. 1a}$$

This is equivalent to Equation 1, but expresses the gain, A_{dB} in *decibels*, not in linear terms (as was A_V). It clearly shows that the decibel gain of the VCA is directly proportional to the control voltage E_C . The constant -166.7 is a scale factor deriving from the control voltage sensitivity of approximately 6mV/dB.

Similarly, recognizing that the detector produces an output proportional to the decibel level of its input signal, we can simplify Equation 2 in the same way:

$$V_{OUT} = 0.006 \text{ dB}_{RMS}. \quad \text{Eq. 2a}$$

In Equation 2a, V_{OUT} is the output of the detector, while dB_{RMS} is the decibel level of its input signal.

Armed with the revised Equations 1a and 2a, let us mathematically explore the action of the processors in Figures 1 and 2.

Feedforward Processor Math

For Figure 1, the feedforward processor, the output signal level is equal to the sum of the input signal level and the VCA gain. (While the VCA *multiplies* the input signal by its linear gain, in the logarithmic world this reduces to *addition*.) Mathematically, this is:

$$\text{dB}_{OUT} = \text{dB}_{IN} + A_{dB}, \quad \text{Eq. 3}$$

where dB_{OUT} is the VCA's output level, dB_{IN} is its input level, and A_{dB} is its gain (all in decibels, of course).

The VCA gain is determined by the control voltage applied to it, which depends on the detector's output voltage and the control-voltage processor gain. From equation 2a and the block diagram, the applied control voltage, E_C , is:

$$E_C = G \cdot 0.006 \text{ dB}_{IN}. \quad \text{Eq. 4}$$

Combining Equations 1a, 3 and 4, we can solve for the output level:

$$\begin{aligned} \text{dB}_{OUT} &= \text{dB}_{IN} + [-166.7 \cdot (G \cdot 0.006 \text{ dB}_{IN})] \\ &= (1 - G) \text{ dB}_{IN}. \end{aligned} \quad \text{Eq. 5}$$

This simple equation points out the inherently linear relationship between decibel input and output levels in dynamic processors based on THAT Corporation VCAs and rms-level detectors.

Compression/Expansion Ratio

In compressor and expander design, the ratio of input level changes to output level changes is frequently referred to. This is called the *compression ratio* (or *expansion ratio*). We can rearrange Equation 5 above to solve for the ratio of the feedforward dynamic processor, as follows:

$$\frac{\text{dB}_{IN}}{\text{dB}_{OUT}} = \frac{1}{(1 - G)}. \quad \text{Eq. 6}$$

Equation 6 shows that the compression or expansion ratio depends only on the gain in the control-voltage processor placed between the detector output and the VCA input. Moreover, whether the processor is a compressor or an expander depends on G .

For $G=0$, the ratio is unity — as would be expected, no dynamic processing takes place. For $1 > G > 0$, the output is less than the input, so the processor is a compressor. For $G < 0$, the output is greater than the input, so the processor is an expander. For $G > 1$, the ratio becomes negative, which results in “negative compression”. In this configuration, the output *decreases* as the

input *increases*. The dynamic inversion thus produced sounds somewhat like playing a tape backwards.

Feedback Processor Math

For Figure 1, the feedback processor, the math is slightly different. Equation 3 still holds, because the signal path is not changed from that in the feedforward processor. However, the control voltage, E_C , is based on the output level, not the input level. Therefore, from Equation 2a and the block diagram:

$$E_C = G \cdot 0.006 \text{ dB}_{OUT}. \quad \text{Eq. 7}$$

Combining Equations 1a, 3 and 7:

$$\begin{aligned} \text{dB}_{OUT} &= \text{dB}_{IN} + [-166.7 \cdot (G \cdot 0.006 \text{ dB}_{OUT})] \\ &= \text{dB}_{IN} - G \text{ dB}_{OUT}. \end{aligned} \quad \text{Eq. 8}$$

Rearranging terms:

$$\text{dB}_{OUT} = \frac{1}{1 + G} \text{dB}_{IN}. \quad \text{Eq. 9}$$

This relationship is nearly as simple as Equation 5 for the feedforward processor.

The ratio can be easily extracted from Equation 9:

$$\frac{\text{dB}_{IN}}{\text{dB}_{OUT}} = 1 + G. \quad \text{Eq. 10}$$

Note the differences between Equation 10 (feedback) and Equation 6 (feedforward). The feedback processor is a compressor for $G > 0$, and an expander for $G < 0$. The ratio function contains a singularity at $G = -1$: at which point the expansion ratio is infinite (and the circuit is unstable!). Infinite compression requires infinite G (and is therefore impossible to achieve, though it is possible to get close).

Practical Dynamic Processors — Introducing a Threshold

As shown, the processors in Figures 1 and 2 form simple, linear comparers. Assuming G is constant, all signal levels, large and small, are subjected to the same ratio. For application as an audio effects device, a practical compressor requires a threshold below which processing stops in order not to bring up noise during pauses in the signal. A noise gate (or expander gate) requires a threshold above which the processing stops in order to pass desired signals without change.

These objectives are easily met by providing a nonlinear circuit which changes the value of G based on the output of the detector. A simple silicon diode rectifier in the control-voltage path will produce a broad transition between regions of processing and no processing. The width of the transition region may be controlled by amplifying the control voltage before passing it through the

diode, and attenuating it afterwards. An operational half-wave rectifier (which linearizes and sharpens the diode characteristic by placing it in the feedback loop of an opamp) will produce a sharp transition between regions of processing and no processing.

It is possible to combine several types of control-voltage processing into one circuit, by using diodes to switch control-voltage processor paths based on the output voltage from the detector. For example, in a feedforward processor, G could be set less than 0 for low values of dB_{IN} , and set greater than 0 for high values of dB_{IN} . This would produce expansion (or gating) below one threshold, and compression above another. More than one compression ratio may be selected, depending on signal level, by providing more than one threshold with multiple, positive values of G . The combinations are limited only by the imagination of the designer.

Mathematically, the effect of adding a nonlinear circuit as discussed above is to split the ratio equation into two or more individual equations, each of which holds only in a specific region of operation. For a typical, sharp-threshold, feedforward, above-threshold compressor, the mathematics would look like this:

$$\frac{\text{dB}_{IN}}{\text{dB}_{OUT}} = \frac{1}{(1 - G)}, \text{ for } \text{dB}_{IN} > \text{threshold},$$

$$\text{and } = 1, \text{ for } \text{dB}_{IN} \leq \text{threshold}.$$

$$\text{Eq. 11}$$

For a more detailed look at these circuits applied to compressors, see AN100A, *Basic Compressor/Limiter Design*, also available from THAT Corporation.

Feedback vs. Feedforward

In choosing between a feedback and feedforward processor design, there are several factors which will influence the decision. There is no simple way to determine which is the best approach, and the designer must weigh the factors in light of the design objectives.

Detector Dynamic Range

In feedforward processors, the level detector is exposed to the entire dynamic range of the input signal. The THAT 2252 provides accurate audio-band rms-to-dc conversion over a 60dB dynamic range, extending to 80dB over a more limited bandwidth. The THAT 4301 Detector has even wider dynamic range. For an above-threshold compressor, this will present little problem since processing is restricted to the dynamic range above threshold (usually less than 60dB).

A feedback compressor has the advantage that the dynamic range at the detector is reduced by the compression action. The feedback configuration was chosen for dbx Type I and II noise reduction encoders (compressors) partly because of this factor. There, the compression ratio is 2:1, with no threshold of compression

(except for frequency shaping, the block diagram resembles Figure 2 quite closely). By placing the detector at the output of the compressor, the dynamic range it must handle is reduced by one-half, allowing a 60dB detector to accommodate 120dB of input dynamic range.

Available Ratios

However, the feedback configuration has the disadvantage that not all compression ratios are possible. The high level of feedback required to reach high compression ratios makes feedback processors more likely to exhibit instabilities if high compression ratios are allowed. Instability is also likely in feedback expanders where high expansion ratios are desired (e.g., noise gates). An additional drawback is that negative compression ratios are not possible. By contrast, all this is possible in feedforward.

Time Constants

While this discussion has not addressed the effect of the detector's time constant on a dynamic processor, it is worth noting that the configuration chosen will affect the processor's transient response. Consider that in either type of compressor, the output will overshoot on sudden transients unless the detector response is instantaneous. The detector in the feedback compressor sees this overshoot, which will modify its response behavior. The detector in the feedforward compressor sees only the input signal, and acts accordingly.

Mirror-Image Symmetry

Certain types of dynamic processors are intended to be used in paired applications, such as the combination of a noise-reduction encoder which is paired with a decoder. In this case, the processing of the encoder, (a compressor) is intended to be inverted, or "un-done" by the decoder (an expander). It is possible to exploit the mirror-image symmetry between feedback and feedforward configurations to help ensure accurate decoding during the expansion process.

Consider the case of the block diagram of Figure 2 (feedback) configured as a compressor, and the block diagram of Figure 1 (feedforward) configured as an expander. If the feedback compressor is used as the encoder, and the feedforward expander as the decoder, a "back-to-back" connection of the two devices would have the output of the feedback circuit connected di-

rectly to the input of the feedforward circuit. In this arrangement, the detectors in each circuit are connected to the same signal, so their responses will be identical over time and level variations, provided the detectors themselves match.

If both processors were feedforward, the detectors would see different signals (the compressor sees its input, the expander sees the compressor's output). With two feedback processors, the detectors again see different signals. Therefore, to provide optimum tracking in encode-decode processor applications, a combination of feedback encoder with feedforward decoder is recommended to provide the best chance for accurate mirror-image processing. (This is one reason why dbx Types I and II and dbx-TV noise reduction use this mirror-image principle in their designs.)

Summary

While at first appearing somewhat formidable, the mathematics of log-based dynamic processors reduces to relatively simple, algebraic equations. Happily for the designer, the constants in the mathematics have clear and direct relation to the circuit elements and performance. Compression and expansion ratios, in particular, are amenable to straightforward mathematical solutions and circuit implementations.

Nonlinear circuits (diodes, operational rectifiers and the like), may be used to provide thresholds (breakpoints in the transfer characteristic). Single and multiple thresholds may be accommodated via the same mathematical analysis.

Feedforward and feedback processors have individual strengths and weaknesses, and in choosing between them the designer should consider such diverse elements as dynamic range, required ratios of compression or expansion, target time constants, and the need for mirror-image symmetry between compressors and expanders.

Closing Thoughts

THAT Corporation welcomes comments, questions and suggestions regarding this application note and its subject matter. Our engineering staff has extensive experience in designing commercial dynamic processors based on our VCAs and rms-level detectors. We are pleased to offer assistance in optimizing your circuitry for your application. Please feel free to contact us with your thoughts and questions.