

MARINE
RADIO AND ELECTRONIC
EQUIPMENT

“ATALANTA” RECEIVER

TYPE 2207C

by

F. C. MAYOH, B.E.M.
(1st Class P.M.G. Certificate)

and

G. L. DANIELSON M.Sc. Tech., B.Sc., A.M.I.E.E.
(1st Class P.M.G. Certificate)

Handbook Ref. R(S) 37.



Marconi Marine "Atalanta" receiver
(Type 2207c)

CONTENTS

PREFACE

SECTION 1

General Description

	Page
1.1 Block Diagrams	1
1.2 Frequency Ranges	2
1.3 Valves	2
1.4 Fuses	2
1.5 Front Panel and Chassis Layout	3
1.6 Specification	3

SECTION 2

Signal Frequencies

2.1 R.F. stages (V1 and V2)	4
2.2 Calibrating Oscillator (V13)	6
2.3 Calibrating action	6

SECTION 3

Frequency Changing

3.1 Frequency Changers (V3, V4 and V5)	8
---	---

SECTION 4

Intermediate Frequency

4.1 I.F. Stages (V6 and V7)	9
4.2 Variable Selectivity	10

SECTION 5

Desensitising and Muting

5.1 Relay Desensitising	11
5.2 Cathode Desensitising	11
5.3 Grid Desensitising	12
5.4 Muting Circuit	13
5.4.1 Under no-signal conditions	14
5.4.2 In the presence of a signal	14

SECTION 6

Detector, Noise Limiter and A.G.C. Circuits

6.1 Beat Frequency Oscillator (V9)	15
6.2 Balanced Demodulator	15
6.3 Noise Limiter and A.G.C. Circuits	17

CONTENTS (Contd.).

		Page
SECTION 7		
Audio Frequency		
7.1	Audio Frequency and Output Stages (V10 and V11) ...	19
SECTION 8		
Power Supplies		
8.1	General	20
8.2	H.T. Supplies	21
8.3	L.T. Supplies	21
SECTION 9		
REVISION		
9.1	Points of Interest	22
9.1.1	R.F. Section (V1, V12 and V13)	22
9.1.2	Frequency Changers (V3, V4 and V5)	22
9.1.3	I.F. Section (V6 and V7)	22
9.1.4	Detector/B.F.O. (V8 and V9)	22
9.1.5	Noise Limiter/A.G.C.	22
9.1.6	A.F. Amplifier and output stages (V10 and V11)	22
9.1.7	Power Supplies (V12)	23
9.1.8	Miscellaneous	23
9.2	Revision Questions	23
9.2.1	Section A	23
9.2.2	Section B	24
9.2.3	Section C	25
APPENDICES		
Appendix No.1.	Magnetostriction	27
Appendix No.2.	Balanced Demodulator	30
Appendix No.3.	Noise Limiter	35

PREFACE

Radio Officers, whether seagoing or under training and others associated with marine radio, who are required to understand the circuitry of communication equipment and other electronic aids to navigation, have, in general, at their disposal an amount of radio knowledge which they accumulated over a period of time, together with the manual relating to the appropriate equipment provided by the manufacturers.

It is usually found that the manuals, although excellent for the purpose for which they are designed are not directly useful for the immediate understanding of the circuit principles involved in unfamiliar equipment and that a considerable amount of groundwork is necessary before some of the circuit diagrams included in the manuals can be re-cast in a form suitable for this kind of study.

The authors of this series are engaged in the large scale training of Radio Officers and, in addition, benefit from many contacts with Marine Inspectors, Technical Assistants and seagoing Radio Officers. They have come to the conclusion that a considerable need exists for publications of a type which will form a bridge between the standard of radio and electronic knowledge likely to be possessed by reasonably advanced Radio Officers under training and the kind of information provided by the manufacturers manuals. In consequence this series of publications has been produced.

In these booklets the circuits shown in the manufacturers manuals have been broken down, re-cast and simplified to show only those features which are essential to an understanding of the method of working. The explanations are based on the assumption of a knowledge of radio principles to a level approaching that of the P.M.G. 2nd. Class Certificate examination. In this way it is expected, and has in practice been found, that P.M.G. students and qualified Radio Officers can rapidly acquire a good knowledge of the methods of functioning of unfamiliar equipment without the need to read through a quantity of basic theory with which they are presumably already familiar, but with the assurance that anything unusual or somewhat advanced- as for instance a balanced demodulator - will be dealt with adequately.

The depth to which explanations are given is sufficient to cover the needs of those studying for the P.M.G. Second and First Class examinations and for such students in particular it is hoped that section 9 will be helpful; in this section items of interest are set out in a concise form and a number of revision questions are posed. It is thought that this will assist in revision and enable the student to assess his understanding of the circuits.

For sea-going Radio Officers or for those working on equipment ashore, the publications present a straight-forward account of the circuit action and include in the Appendices an account of any unusual features or circuit elements, when this is thought to be advisable.

If the booklets are used in conjunction with the appropriate manufacturers manuals the user should acquire the necessary understanding and information to maintain the equipment in good working order and to diagnose the cause of a fault, locate and rectify it as necessary.

This series could not have appeared in its present form without the kindly interest and effective help in the launching of the project given by Mr. L.A. Hooper, Manager, Technical Information Department, and Mr. F.E. Ash, Superintendent of Training, of The Marconi International Marine Communication Co. Ltd., to both of whom acknowledgement is gratefully made.

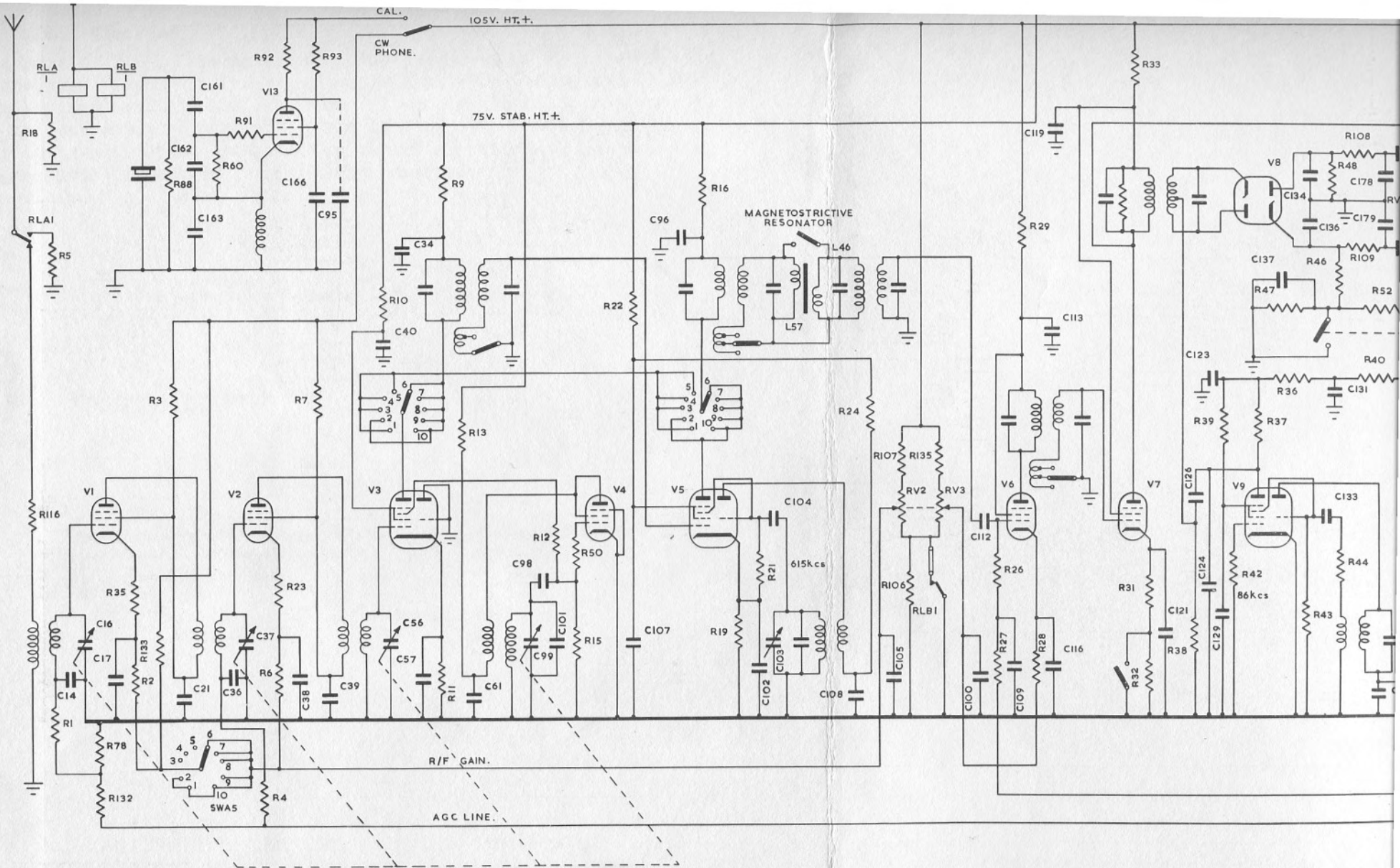

ABRIDGED CIRCUIT DIAGRAM OF "ATALANTA" MARIN

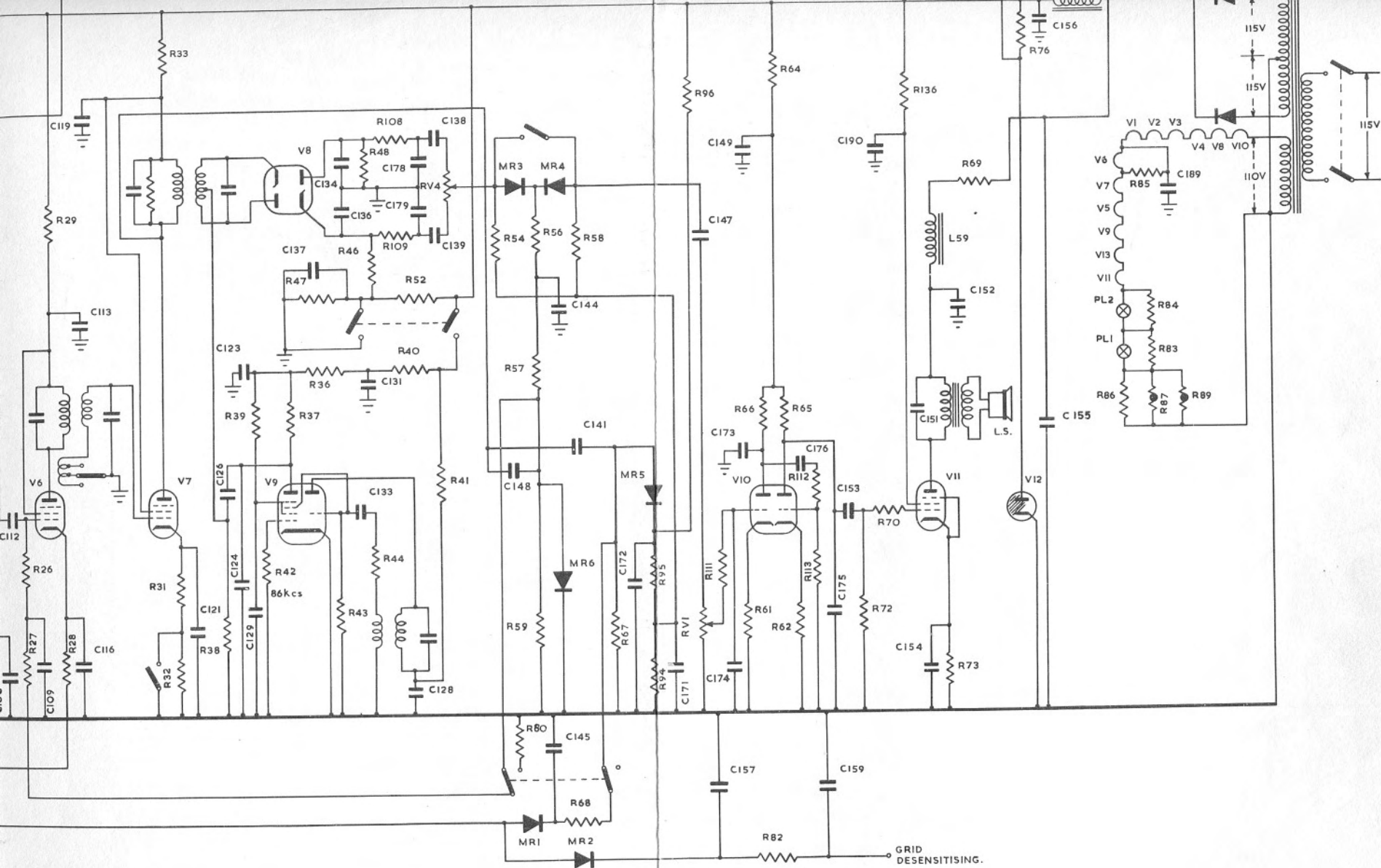

CIRCUIT DIAGRAM OF "ATALANTA" MARINE RECEIVER

FIG. 1

GENERAL DESCRIPTION

Section 1

1.1 Block Diagrams

Section 1.2 gives details of the frequencies covered by each of the ten ranges of the receiver and of the intermediate frequencies employed. Block diagrams of the receiver, appropriate to the various wave-ranges, are shown in Figs. 2, 3 and 4 and should help the reader keep in mind the overall picture while studying the explanations of the individual circuits.

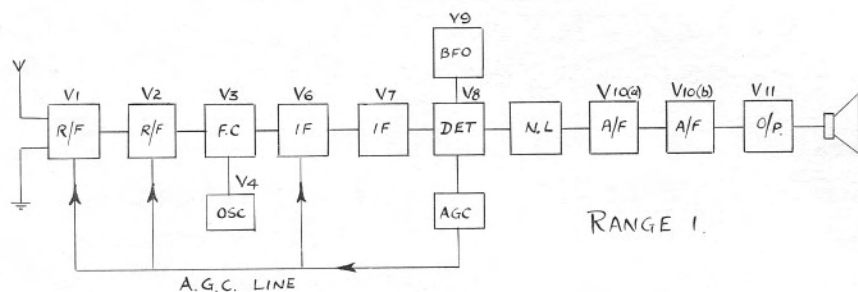

FIG. 2

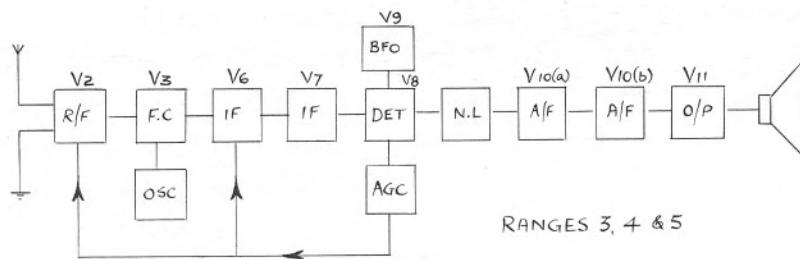

FIG. 3

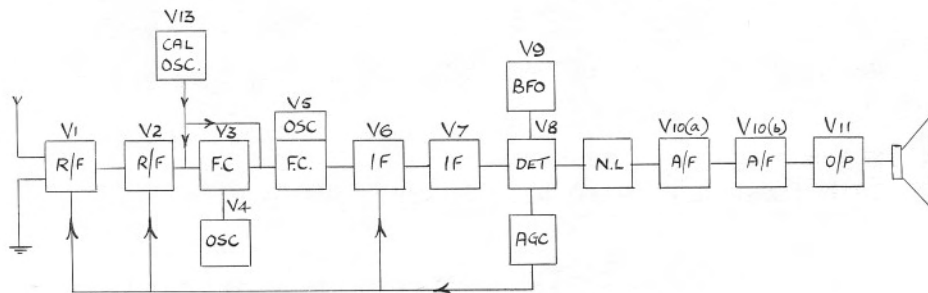

FIG. 4.

1.2 Frequency Ranges

Range	1.	- - -	15	-	25	kc/s.	- - -	I.F.	85	kc/s.	
"	2.	- - -	25	-	100	kc/s.	- - -	I.F.	700	kc/s & 85	kc/s.
"	3.	- - -	100	-	200	kc/s.	- - -	I.F.	85	kc/s.	
"	4.	- - -	200	-	400	kc/s.	- - -	I.F.	85	kc/s.	
"	5.	- - -	400	-	800	kc/s.	- - -	I.F.	85	kc/s.	
"	6.	- - -	800	-	1.7	Mc/s.	- - -	I.F.	700	kc/s & 85	kc/s.
"	7.	- - -	1.7	-	3.6	Mc/s.	- - -	I.F.	"	"	"
"	8.	- - -	3.6	-	7.5	Mc/s.	- - -	I.F.	"	"	"
"	9.	- - -	7.5	-	15.0	Mc/s.	- - -	I.F.	"	"	"
"	10.	- - -	15.0	-	28.0	Mc/s	- - -	I.F.	"	"	"

1.3 Valves

V1.	- - -	EF85 or W719	- - -	variable-mu pentode.
V2.	- - -	EF85 or W719	- - -	variable-mu pentode.
V3.	- - -	ECH81 or X719	- -	triode heptode.
V4.	- - -	EF85 or W719	- - -	variable-mu pentode.
V5.	- - -	ECH81 or X719	- -	triode heptode.
V6.	- - -	W77 <i>CV131</i>	- - -	variable-mu pentode. <i>6CQ6</i>
V7.	- - -	Z77 <i>EF92</i>	- - -	pentode. <i>CV138 EF91</i>
V8.	- - -	D77 or EB91	- - -	double diode.
V9.	- - -	ECH81 or X719	- -	triode heptode.
V10	- - -	B309 or 6060	- - -	double triode.
V11	- - -	N37.	- - -	power pentode.
V12	- - -	QS75/20	- - -	voltage stabiliser.
V13	- - -	Z77	- - -	pentode.
V14	- - -	ECH81 or X719	- -	triode heptode. (optional fitting)

Metal rectifiers, MR1 to MR7, are of the single disc selenium type.

1.4 Fuses

Both fuses are rated at 1.0 amp. See Fig.5.

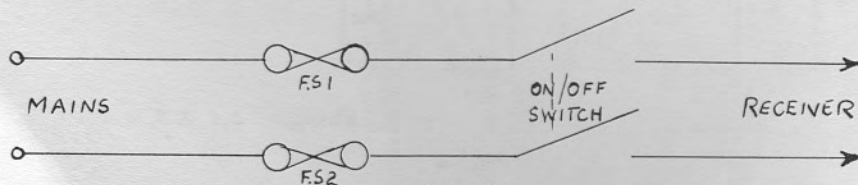
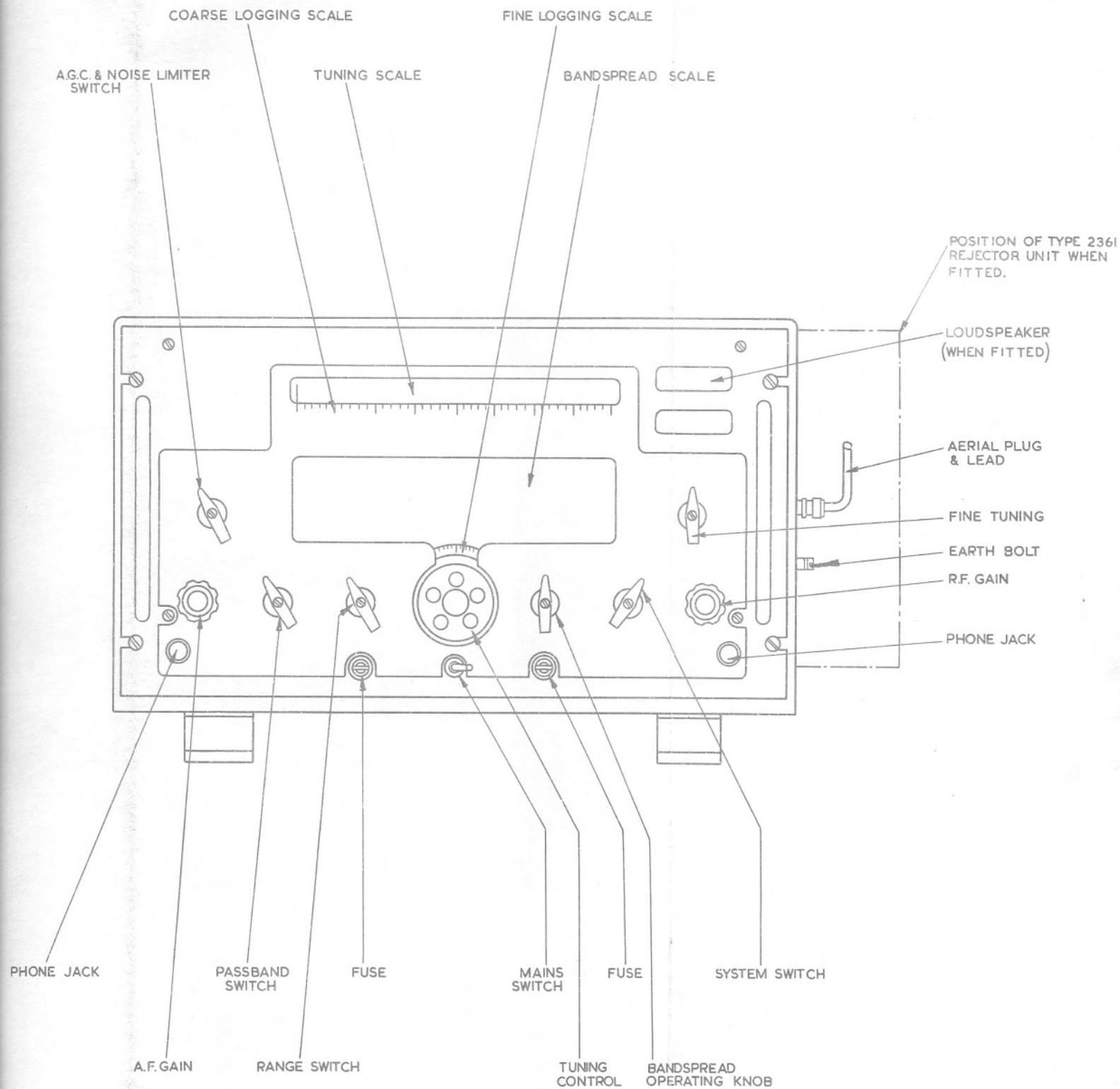
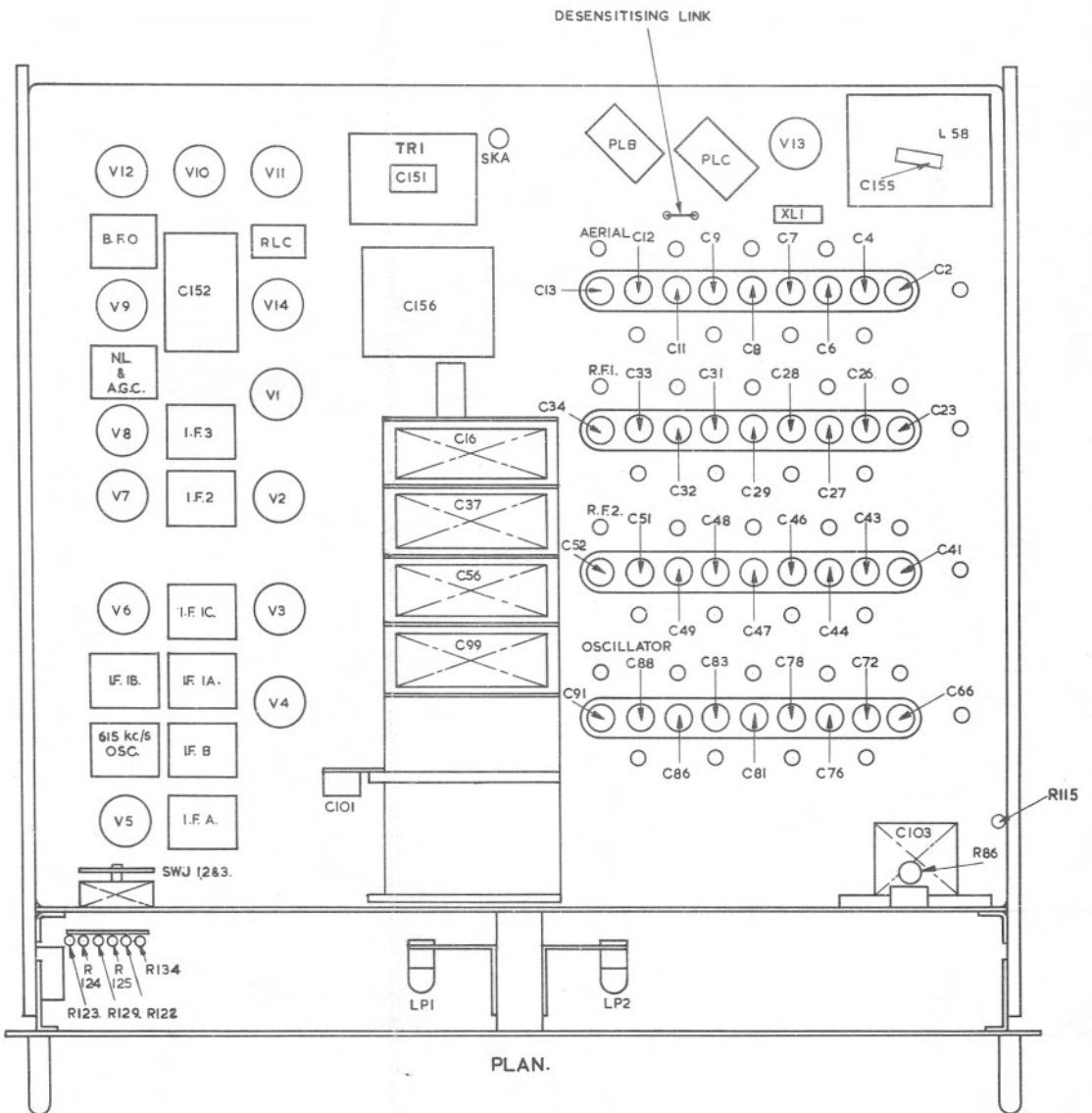

FIG. 5



OUTLINE OF FRONT PANEL, CONTROL AND FUSE POSITIONS OF 'ATALANTA' RECEIVER (TYPE 2207C)



COMPONENT LOCATION OF ATALANTA RECEIVER (TYPE 2207C) CHASSIS

1.5 Front Panel and Chassis Layout

Figs. 6 and 7 show the front panel and the chassis layout of the receiver.

Note:- The filter and A.C. power unit are mounted at the rear of the case.

When operated from 200 volts D.C. the dropping resistance can be fitted externally or at the rear of the case.

1.6 Specification

The specification for the receiver will be found in the manufacturers manual. For general information regarding the minimum permissible specifications of marine receivers, and other marine equipment, the reader should consult the Merchant Shipping (Radio) Rules, published by Her Majesty's Stationery Office.

SIGNAL FREQUENCIES

Section 2

2.1 R.F. Stages (V1 and V2)

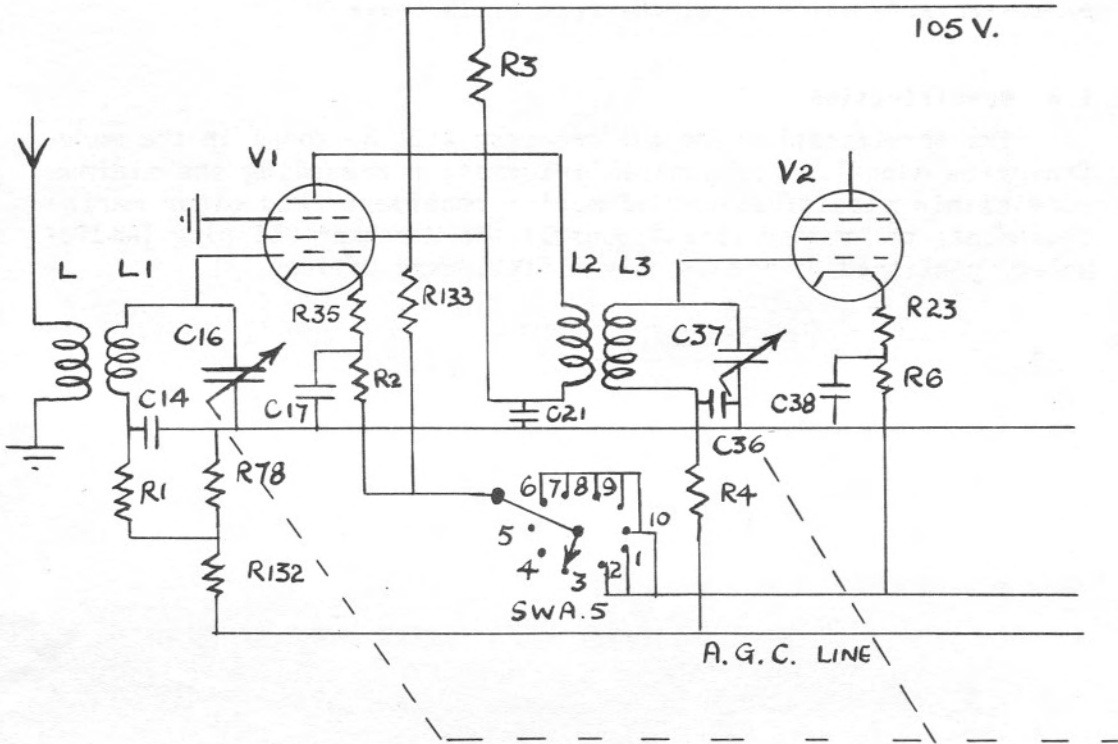

FIG. 8

Figures 1 and 8 refer.

On ranges 3, 4 and 5, valve V1 is cut-out of circuit by the range switch SWA 5 which disconnects the cathode of V1 from the H.T. negative line and thus stops the flow of current through resistor R133 so that the cathode potential rises to some H.T. positive potential thus holding V1 non-conducting. At the same time, although not shown in Fig. 8, the wave-range switch connects L2 across the tuned circuit L1C16 so that L2 acts as a link coupling between the aerial and the input circuit to V2, L3C37.

On range 6 an I.F. rejector circuit, tuned to 700 kc/s, is

brought into circuit in series with the output of V1. This is incorporated as the R.F. stages of the receiver, when tuned to the lowest frequency in this range - 800 kc/s - might not completely reject a powerful unwanted signal on about 700 kc/s; any small residuum of this, entering the I.F. section, would there receive full amplification since the I.F. section is itself tuned to 700 kc/s. The rejector circuit is not shown in figure 8.

At the upper end of ranges 4 and 5 there is the possibility that the high value of image protection laid down in the specification of the receiver (85 dB), might not be met. Consequently, an image rejector circuit, C50L55, tuned to approximately 950 kc/s is employed on range 5, while the same circuit with C50 paralleled by another capacitor, C45, to reduce the frequency to approximately 550 kc/s, is used on range 4. These rejector circuits are included in series with the anode load of V2 and clearly give the maximum protection at, respectively, $(950-2 \times 85)$ kc/s and at $(550-2 \times 85)$ kc/s; i.e. at 780 kc/s in range 5 and at 380 kc/s in range 4.

For information regarding the minimum performance permitted in marine receivers see the Radio Rules referred to in Section 1.6.

The single frequency changer technique used on ranges 1, 3, 4 and 5, with an I.F. of 85 kc/s, cannot be employed on range 2 since the frequency of 85 kc/s is included in this band. Accordingly a double frequency change, as used on ranges 6, 7, 8, 9 and 10, is also provided for range 2.

The fact that the first I.F. is thus fixed at 700 kc/s would give rise to tracking difficulties if an attempt were made to tune both the signal frequency and oscillator circuits by means of ganged capacitors; this can be seen from the following table which shows that the required signal frequency change is more than three times the corresponding oscillator frequency change.

	I.F. = 700 kc/s	
Signal frequency	25 - 100 kc/s	$f_{\max}/f_{\min} = 4$
Osc. frequency	725 - 800 kc/s	$f_{\max}/f_{\min} = 1.1$

For this wave-range, therefore, the signal frequency circuits are untuned and consist of an untuned transformer input with high and low pass filters resulting in a broad band R.F. circuit covering the whole range 25 kc/s to 100 kc/s.

Frequency selection in this range is provided solely by the manual tuning of the oscillator.

In order to render the gain of the receiver as constant as possible, over the wide frequency range covered, (15 kc/s to 28 Mc/s), a small amount of negative feedback is applied to the inputs of V1 and V2 by leaving resistors R35 and R23 in the cathode circuits un-bypassed.

2.2 Calibrating Oscillator (V13)

This circuit oscillates at 700 kc/s and, owing to the need for extreme frequency stability, is crystal controlled. In order to provide an output rich in harmonics, electron coupling is employed; by this means ample calibrating signal is obtained even at frequencies requiring the use of a high order of harmonic from the calibrator, in fact up to 28 Mc/s, the upper frequency limit of the receiver.

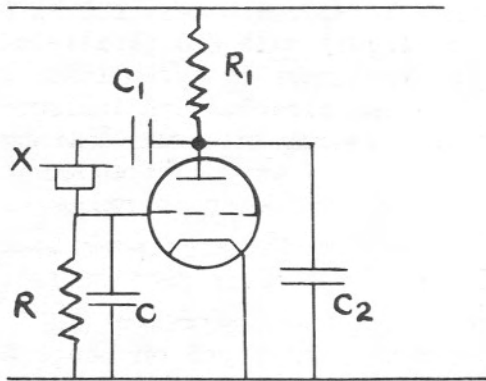

FIG. 9

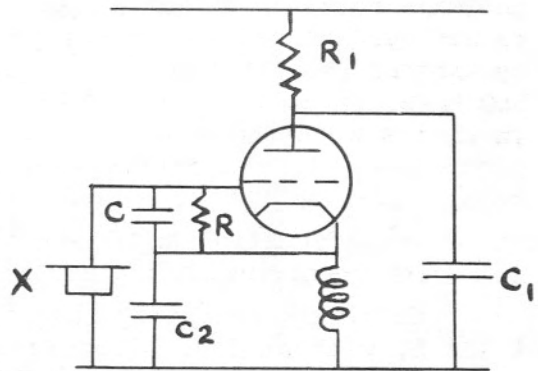

FIG. 10

Figures 9, 10 and 11 show the development of the oscillator from the standard Pierce type (Fig.9), through the inverted Pierce type (Fig. 10) in which the output may be taken from anode or cathode, to the actual circuit employed in the receiver (Fig. 11). Here the capacitors C161, C162 and C163 form a potential divider between the crystal and the valve, resistor R88 (150 k ohms) provides a conductive path for C161 which is otherwise isolated, while R60 with C162 provides grid bias for the valve. R91, of 47 ohms, is a grid stopper.

The output from the anode is taken by a long lead which passes close to the output and input circuits of V3 before earthing via C95, so that signals at calibrator frequency and its harmonics appear in both circuits.

2.3 Calibrating Action

Switching the receiver to "Calibrate" results in:-

- (a) The application of H.T. to the calibrator oscillator (Cal. Osc.) V13.
- (b) The removal of H.T. from V1 and V2 to prevent the reception of external signals - unless exceptionally strong.

- (c) The removal of H.T. from the B.F.O. for a reason which will soon become clear.
- (d) The switching of the detector to "Phone" operation (see Section 6.2).

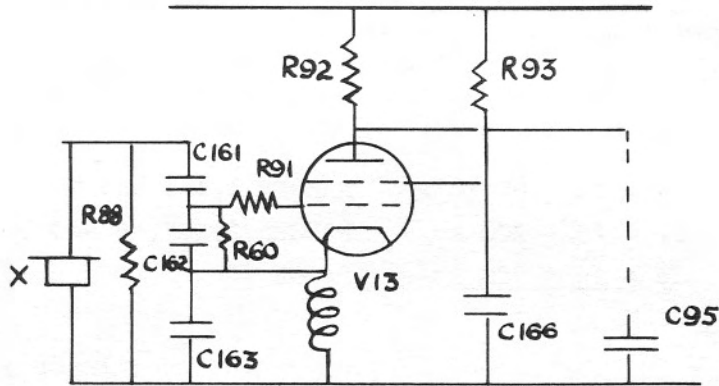

FIG. 11

The receiver is tuned to the region in which it is desired to effect calibration, say about 4 Mc/s. At 4.2 Mc/s on the tuning scale a good signal should be developed at the grid of V3 from the sixth harmonic of the calibrator oscillator and this will beat with the 4.9 Mc/s now being generated in the local oscillator to create an output from V3 at about 700 kc/s ($4.9 \text{ Mc/s} - 4.2 \text{ Mc/s}$); how close this frequency is to 700 kc/s depends on the accuracy of the receiver tuning scale. Also in the output is a voltage at exactly 700 kc/s, this being coupled directly from the calibrator oscillator (via the long lead referred to in Section 2.2). These two frequencies are amplified and by the action of the local oscillator associated with V5 are changed to frequencies of, respectively, approximately 85 kc/s and, exactly 85 kc/s. Because the B.F.O. has been switched off by the action of the calibrator switch these two frequencies alone appear at the input to the detector where they beat to produce a note at the difference frequency. If the receiver is now tuned to zero beat i.e. to exactly 4.2 Mc/s in our example, the scale reading may now be checked; if it is accurate it will, of course, read exactly 4.2 Mc/s.

The process can be carried out at any frequency which is a multiple of 700 kc/s (in the H.F. bands) and it can also be used to set up the receiver for bandspreading in the six marine H.F. bands as described in the manufacturers manual.

FREQUENCY CHANGING

Section 3

3.1 Frequency Changers (V3, V4 and V5)

Two intermediate frequencies are used, the tuned circuits of the oscillator (V4) being arranged to produce the appropriate frequency, f_o , as shown in the table below; f_s is the signal frequency.

$f_o = f_s + 85 \text{ kc/s}$	RANGES 1,3,4 and 5
$f_o = f_s + 700 \text{ kc/s}$	RANGES 2,6,7, 8 and 9
$f_o = \frac{f_s + 700 \text{ kc/s}}{2}$	RANGE 10

On range 10, the second harmonic of the oscillator is employed so that the maximum oscillator frequency necessary is about 15 Mc/s instead of about 30 Mc/s as would otherwise be the case; frequency stability is therefore improved. Radiation effects due to the local oscillator will also be reduced since the signal circuits are tuned to a different frequency than the oscillator; also the possibility of the oscillator being pulled while tuning the signal circuits is minimised.

The triode section of V3 (Fig. 1), is not employed in the local oscillator circuit, instead a separate valve, V4, is used for this purpose; this results in better signal/noise ratio and also in improved frequency stability.

C101, in shunt with C99, the tuning capacitor of V4, is for temperature compensation, thus further improving frequency stability.

The input to the second frequency changer, V5, is always at 700 kc/s so that the oscillator does not need to be tunable over a wide range; it is, in fact, basically a fixed frequency oscillator tuned to 615 kc/s, but a small variable capacitor, C103 in Fig. 1, provides for a variation of $\pm 3 \text{ kc/s}$ on all frequencies which employ this intermediate frequency so that fine tuning is available; under conditions of interference this is an exceedingly useful facility. At V5 the signal is fairly large and the frequency relatively low; there is, therefore, no need to employ a separate oscillator to improve either stability or signal/noise ratio: in this case, accordingly, the triode section is employed as the local oscillator valve.

INTERMEDIATE FREQUENCY

Section 4

4.1 I.F. Stages (V6, V7)

V6 is the first intermediate frequency amplifier and has simple A.G.C. together with manual gain control (Fig. 12).

V7 has neither A.G.C. nor manual gain control.

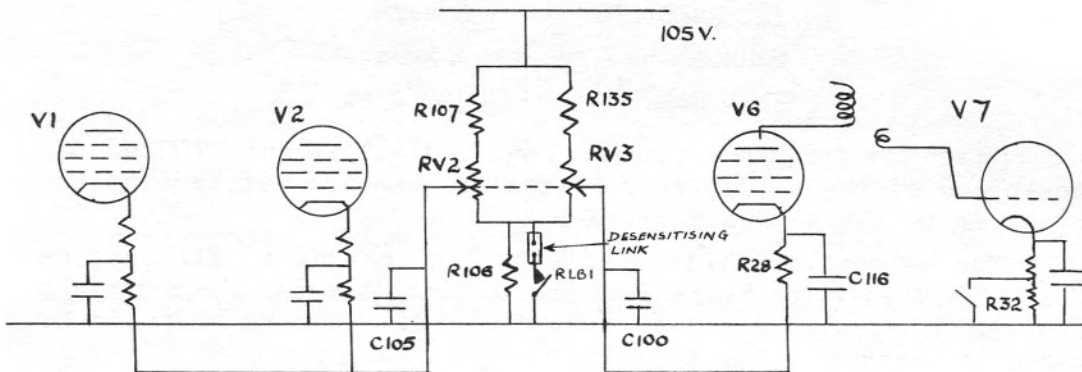

FIG. 12

RV2 is an inverse log law potentiometer which provides bias for the R.F. valves; RV3 is a log law potentiometer by means of which the bias on the first I.F. amplifier V6 can be varied. The two potentiometers are ganged together and form the R.F. gain control.

It is interesting to note that the resistors R2, R6, and R28 (see Fig. 1) which provide standing cathode bias for V1, V2 and V6 are most essential, for when the R.F. gain control is at a maximum and the A.G.C. is switched off, they provide the only bias on these valves.

Other things being equal, the narrower the bandwidth the higher the gain of the receiver. In order to render the overall gain as constant as possible the circuit provides for the inclusion of an additional cathode bias resistor for V7 when operating in the INTERMEDIATE and NARROW positions thus reducing the gain

of this valve and so counteracting the general tendency of the gain to increase: this is arranged by ensuring that the switch across R32 is then open. In the WIDE position the switch is closed thus shorting out R32 and increasing the gain of V7. The next Section, and also Appendix 1, refer to the filter employed to obtain VERY NARROW bandwidth; to minimise as much as possible any change in overall gain in this case V7 must be in its most sensitive condition and R32 is again shorted.

4.2 Variable Selectivity

Four values of selectivity are provided:

WIDE	- - -	8 kc/s.
INTERMEDIATE	- - -	3 kc/s.
NARROW	- - -	1 kc/s.
VERY NARROW	- - -	100 c/s.

On the low frequency ranges, 1 and 2, the WIDE and INTERMEDIATE positions of the selectivity switch are shorted out leaving the receiver in the NARROW position.

The selectivity switch effects its control in all but the VERY NARROW position by varying the coupling between the primaries and secondaries of the I.F. transformers. This is arranged by means of switched mutually inductive windings connected in series with the respective secondaries. For the VERY NARROW position the magnetostrictive filter is brought into operation (see Appendix 1).

The 700 kc/s I.F. transformer has two pass bands only; 14 kc/s in the WIDE and INTERMEDIATE, and 8 kc/s in the NARROW and VERY NARROW positions of the selectivity switch. This enables the fine tuning control C103 (Fig. 1) in the oscillator circuit of V5 to be used (see Section 3.1).

The 85 kc/s I.F. transformers have three selectivity positions: 8 kc/s, 3 kc/s and 1 kc/s as above.

DESENSITISING AND MUTING

Section 5

5.1 Relay Desensitising

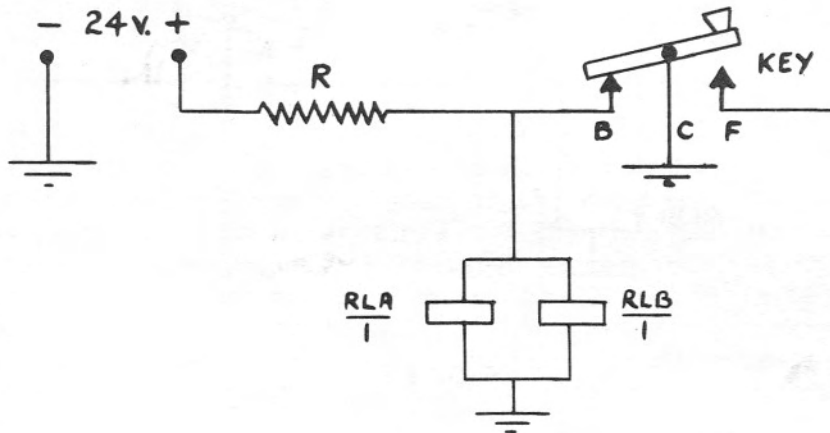

FIG. 13

Refer to Fig.1 and Fig.13.

With key up, RLA/1 and RLB/1 are short-circuited by the back contacts of the key and the 24 volts is entirely dropped by the resistor R, located in the "Autokey", where the 24 volts is obtained. When the key is down, RLA/1 and RLB/1 are energised by the 24 volt supply through R. In this condition, RLA1 earths the aerial through R5 (Fig.1) and disconnects it from the receiver. At the same time RLB1 opens, putting R106 (see also Fig.12) in series with RV2 and RV3: this causes the cathodes of V1, V2 and V6 to be driven so positive by the voltage dropped across R106, that they cut off.

In this way the receiver is isolated and protected from the signals being transmitted.

5.2 Cathode Desensitising

When no 24 volt supply is available to operate relays RLA and RLB, the system shown in Fig.14 can be employed. With the desensitising link open the resistor R106 is short-circuited through the back contacts of the key when the key is up. On pressing the key, R106 is brought into circuit in series with potentiometers RV2 and RV3, causing V1, V2 and V6 to cut off due to the rise in their cathode potential.

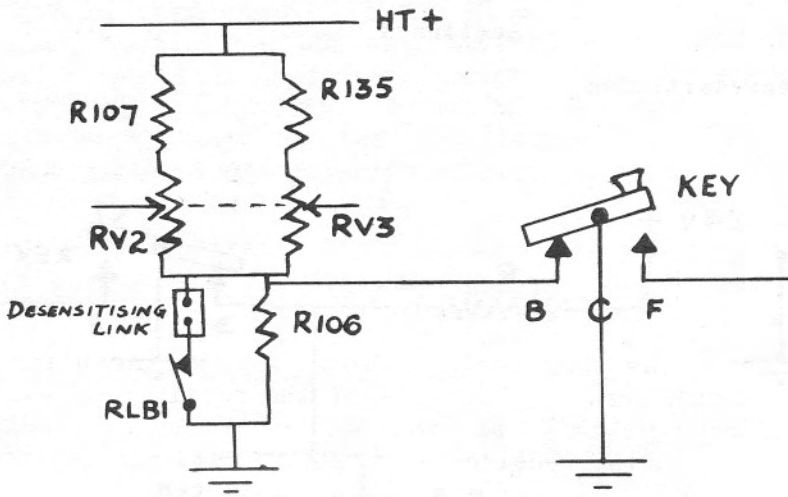

FIG. 14.

5.3 Grid Desensitising

A negative voltage of 40 to 50 volts, derived from the transmitter final stage grid, is applied to the receiver A.G.C. line as shown in Fig.15, when Voice Operated Carrier (V.O.C.) is employed.

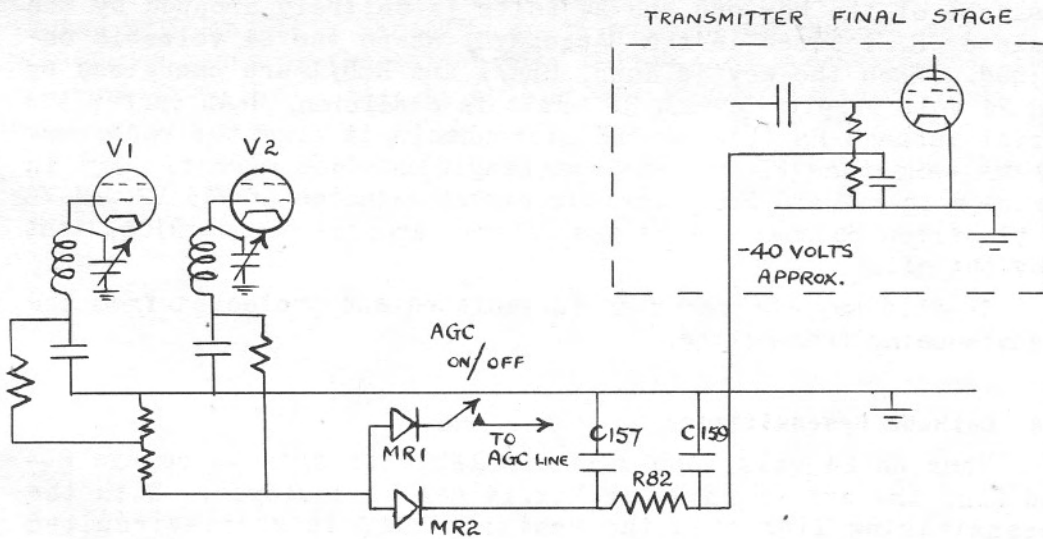

FIG. 15

The use of rectifiers MR1 and MR2 enables the A.G.C. and V.O.C. desensitising voltages to operate independently and to allow the larger voltage to override and be operative on the A.G.C. line.

The filter R82, C157 and C159 in the V.O.C. desensitising line, unlike the A.G.C. rectifier filter, has a short time constant so that the desensitising voltage can operate on the controlled valves very quickly, whilst the application and decay of A.G.C. voltage is much slower.

5.4 Muting Circuit

The receiver has been designed to allow the inclusion of a muting circuit which reduces the gain of the receiver by about 20 dBs, (a) when tuning between stations and (b) when the carrier of the station to which the receiver is tuned is removed; as happens for instance, when tuned to an area or coast station in between the transmissions of the station. In these two sets of circumstances a receiver not fitted with a muting circuit operates at a very high level of gain, the A.G.C. voltages having fallen

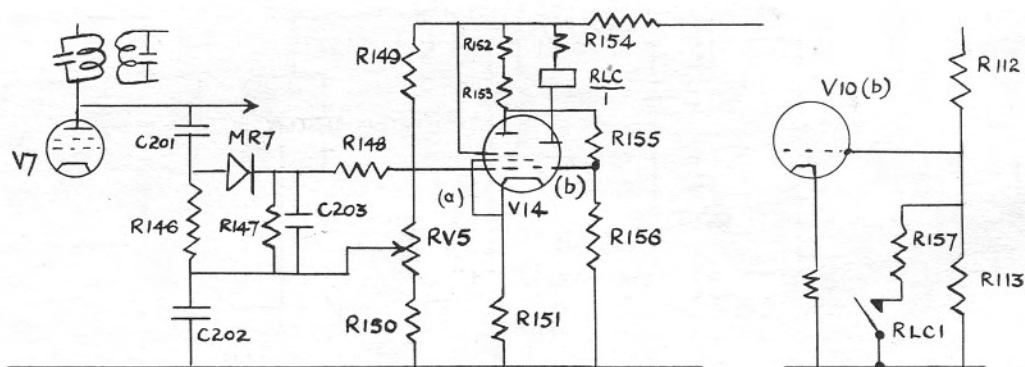

FIG. 16

drastically owing to the absence of a signal (see Section 6.3), so that the noise level is very high. The provision of the muting facility means that the operations of tuning and monitoring can be carried out with a quiet background, a facility which is always of great convenience and in a busy station can be of much importance.

5.4.1 Under no-signal conditions: V14(a) is cut-off and its anode is, therefore, very positive thus holding the grid of V14(b) positive. This causes (V14(b) to conduct heavily and energise RLC/1 which is in its anode circuit; as a result contact RLC1 closes, placing R157 in shunt with R113 in the input circuit to the A.F. amplifier V10(b). Since the value of R157 is less than 10 per cent of that of R113 it will be seen that this causes a very considerable fall in the input to V10(b) and thus brings about the 20 dB reduction referred to.

5.4.2 In the presence of a signal: MR7 rectifies the signal from the I.F. amplifier V7 producing a positive-going output which causes V14(a) to conduct, creating a drop in its anode potential and in the grid potential of V14(b). V14(b) cuts off, RLC/1 is de-energised and the contacts RLC1 open, thus removing the shunt resistance R157 and allowing the full A.F. input to be applied to V10(b).

DETECTOR, NOISE LIMITER AND A.G.C. CIRCUITS

Section 6

6.1 Beat Frequency Oscillator, (V9)

A triode oscillator having anode circuits fixed-tuned to 86 kc/s is followed by a heptode, in the same glass envelope, acting as an isolating amplifier. The output is developed across resistor R38 and injected into the balanced demodulator at the centre tap of the last I.F. transformer secondary. Injection in this manner, with the very minimum of coupling between the B.F.O. and the I.F. amplifier, virtually prevents pulling of the B.F.O.

Any harmonics generated by the B.F.O. are mostly by-passed to earth by the relatively low reactance of C124 at these higher frequencies, (Fig.1). At 86 kc/s the reactance is about 8,500 ohms - C124 has a capacitance of 220 pF - and at the higher harmonic frequencies this value of reactance is progressively reduced. The possibility of the creation of any unwanted spurious beat notes, which might otherwise be contributed to by the harmonics, is thus largely avoided.

6.2 Balanced Demodulator

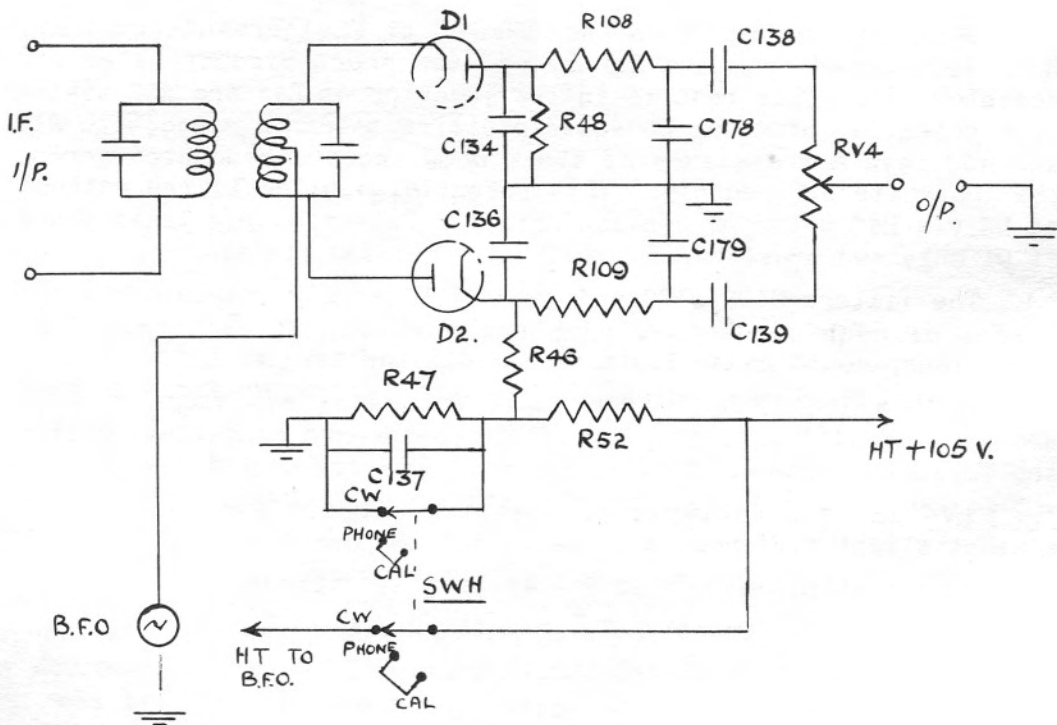

FIG. 17

The circuit employed is shown in Fig. 17 and the main components are tabulated below. A brief description of the circuit follows while a more detailed description will be found in Appendix 2.

Component Ref.	Function
C134/R48	Load of D1.
C136/R46	Load of D2.
R108/C178	Filter circuits to remove the I.F. component from the outputs of D1. and D2 respectively.
R109/C179)	
C138	D.C. blocking capacitor.
C139	D.C. blocking capacitor.
RV4	Output balancing resistor.

The switch SWH is part of the system switch (C.W., Phone, Calibrate) and is shown in the C.W. position in Fig.17. In this position H.T. is applied to the B.F.O. and R47 is short circuited so that R46, the load resistor of diode D2, is connected to earth. Thus the B.F.O. is in an operative condition and both the diodes are in circuit. The circuit is now ready for the reception of C.W.

When switch SWH is in the "Phone" or "Calibrate" position, H.T. is removed from the B.F.O. and the short circuit taken off resistor R47. This results in the junction of R47 and R52 taking up a potential of about 50 volts positive to earth since both R47 and R52 have a resistance of 470 k ohms and are connected across the 105 volts H.T. supply. This potential applied to the cathode of D2 via R46 holds D2 non-conducting. Detection now takes place at D1 only and provides an output on modulated signals.

The filters R108/C178 and R109/C179 largely extract from the output of each diode I.F. components which, if not removed at this stage, could cause instability in later stages.

C138 and C139 both have small values of reactance at A.F. and are included to isolate the D.C. components of detection from the following stages.

RV4 is made variable so that the circuit can be balanced against slight differences in valve and component values.

To adjust potentiometer RV4 proceed as follows:-

- (a) Disconnect H.T. from the B.F.O.
- (b) Apply a modulated input signal to the receiver.
- (c) Set the system switch to "C.W."
- (d) Adjust RV4 for minimum output.

6.3 NOISE LIMITER AND AGC CIRCUITS

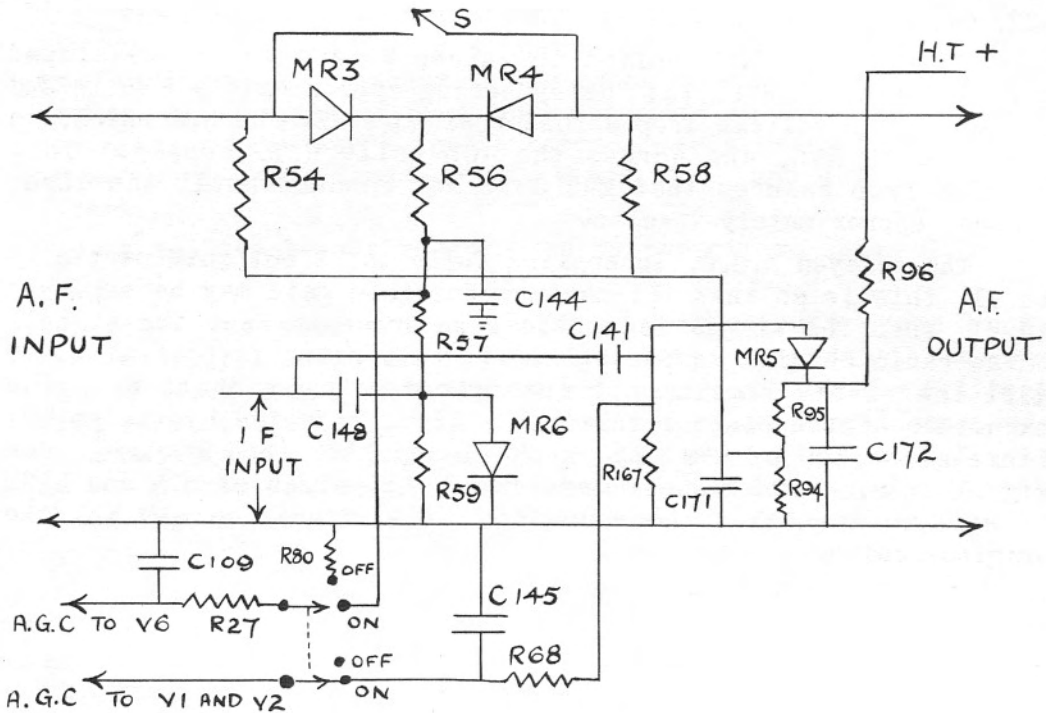

FIG. 18

Fig.18 shows the limiter and A.G.C. circuits. A more detailed explanation of the action of the noise limiter will be found in Appendix 3.

Resistors R54 and R56 (compare with R1 and R3 in Fig.33) constitute the load of MR3, while R58 and R56 act similarly for MR4.

R59 is the load resistor of MR6 and across this resistor is developed a voltage proportional in amplitude to the average I.F. input voltage, which, after filtering of A.F. and I.F. components by R57 and C144, is applied as a negative D.C. control bias to MR3 and MR4 and so determines the level at which clipping begins.

When "S" in Fig. 18 is open the noise limiter is "ON" and

clips noise impulses of larger amplitude than the mean signal level. When "S" is closed MR3 and MR4 are short circuited and the limiting action is not initiated.

The voltage, referred to above, which is developed across R59 is also employed, after I.F. and A.F. filtering by R57, C144 and R27, C109 to provide simple A.G.C. to V6.

Delayed A.G.C., applied to valves V1 and V2, is developed across resistor R67; the "delay" being approximately 7 volts and caused by the voltage drop across resistors R94 and R95 which, in series with R96, are across the 105 volts H.T. supply. This voltage drop ensures that MR5 does not conduct until the input exceeds approximately 7 volts.

The delayed A.G.C. is applied fully to V2 but only partially to V1, this is so that the maximum possible gain may be employed in V1 when the signal is smallest in order to keep the signal/noise ratio as high as possible; if this ratio is poor at V1 it will inevitably remain poor throughout. The reduction in the magnitude of the control voltage to V1 is effected by the potentiometer action of R78 (820 k ohms) and R132 (680 k ohms), see Figs.1 or 8. From a consideration of the values of R78 and R132 it will be seen that the reduction is to approximately half the original value.

AUDIO FREQUENCY

Section 7

7.1 Audio Frequency and Output Stages (V10 and V11)

The provision of sufficient audio-frequency gain for use in the VERY NARROW selectivity position introduces the danger of overloading when operating in the other selectivity positions. To prevent this, negative feedback is applied to the two A.F. stages (by means of resistors in the cathode leads of these valves) and in addition, grid limiting resistors, R111 and R70 (Fig.1), are fitted.

Fixed treble cut is effected by capacitors C174, C173, C175 and C151.

There is a possibility that the relatively large current changes in V11 could set up voltage changes across the impedance of the power supply and that these changes, transferred to the grid of V10(b) (Fig.1) via the H.T. line and R66 and hence arriving back in V11 in the same phase as the original signal, might be of sufficient magnitude to cause instability. Additional smoothing in the anode lead of this valve is therefore provided by L59 and C152.

When the 'phone jack is inserted the loudspeaker is disconnected and a 4.7 ohms resistor connected in its place, thus maintaining the correct anode load impedance for the output valve. The 'phones, of some 600 ohms impedance, are connected in parallel with this resistor.

POWER SUPPLIES

Section 8

8.1 General

The receiver is suitable for operation as follows:-

- (a) Direct from 110 volts D.C. (Fig.19).
- (b) From 220 volts D.C. using a dropping resistor to reduce the voltage to 110 volts at the receiver power supply input. (Fig.20).
- (c) From 24 volts D.C. using a rotary transformer. (Supply unit type 2203A - see manufacturers manual).
- (d) From 115 volts, 50 c/s A.C. using the A.C. power unit shown in Fig.1.
- (e) From 200/250 volts, 50 c/s A.C. using a similar power unit to that employed in (d) but with the transformer modified to suit the higher voltage.

A mains filter is incorporated to reduce mains borne R.F. interference (Fig.21).

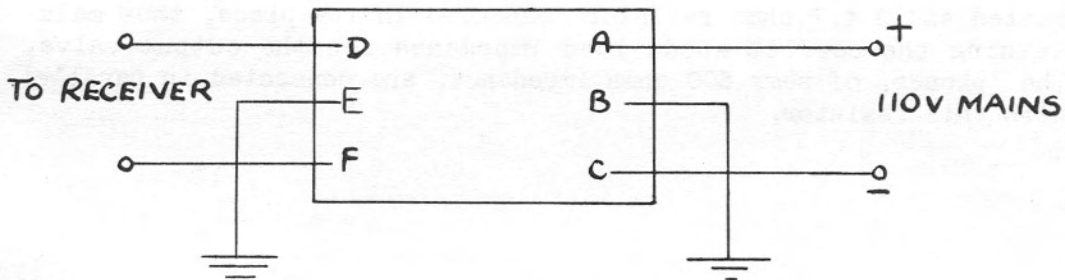

FIG. 19

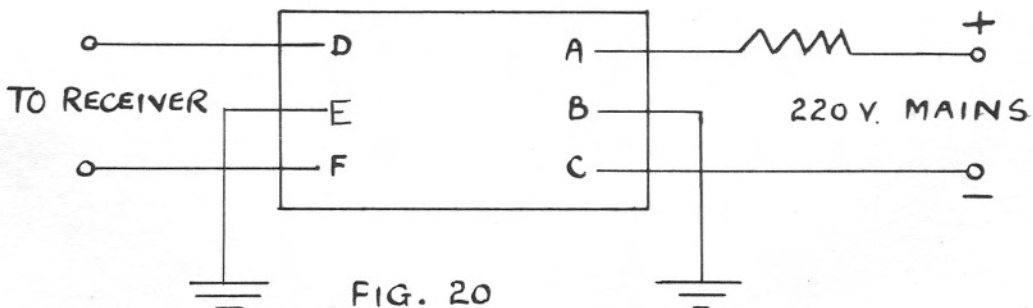

FIG. 20

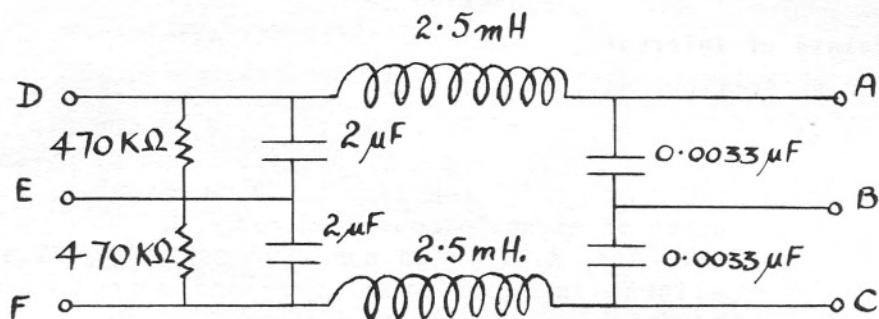

FIG. 21

8.2 H.T. Supplies

V12 and its regulating resistor R76 (Fig.1) provide a stabilised 75 volts which is used to supply the two frequency changers only.

The rest of the receiver takes an H.T. of about 105 volts from the power unit smoothed by the filter L58, C156.

8.3 L.T. Supplies

Series heater connections are employed, with R87 and R89 thermistors (Fig.1) to limit the surge current when the valve filaments are cold.

Thermistors (thermal resistors) are semi-conductors having a large negative temperature coefficient and non-linear characteristics. When cold the resistance is very high but drops sharply as temperature rises; in this way the current which can pass when the equipment is switched on, when valve filaments are cold and therefore of low resistance, is limited and damaging surges are eliminated.

REVISION
Section 9

9.1 Points of Interest

9.1.1 R.F. Section (V1, V12 and V13)

- (a) Ranges using one R.F. amplifier (3, 4 and 5).
- (b) Method of switching R.F. Amplifier out of circuit.
- (c) Method of aerial coupling to V2 on ranges 3, 4 and 5.
- (d) Tuning of signal circuits on range 2.
- (e) R.F. gain, A.G.C. and negative feedback, V1 and V2.
- (f) Calibrating oscillator, type and method of signal injection.
- (g) I.F. rejector circuit, range used and reason for choice.

9.1.2 Frequency changers (V3, V4 and V5)

- (a) Ranges using two frequency changers (2,6,7,8,9 and 10).
- (b) Ranges using one frequency changer (1,3,4 and 5).
- (c) Separate oscillator for first frequency changer, reasons.
- (d) Oscillator frequency band on range 10, reasons.
- (e) Oscillator frequency for second frequency changer; fine tuning.

9.1.3 I.F. Section (V6 and V7)

- (a) Selectivity.
- (b) Magnetostrictive resonator.
- (c) Switched gain of V7.
- (d) A.G.C. to V6.

9.1.4 Detector/B.F.O. (V8 and V9)

- (a) C.W./Phone reception and switching.
- (b) B.F.O. oscillator and amplifier.
- (c) Method of B.F.O. injection including advantages.

9.1.5 Noise Limiter/A.G.C.

- (a) Bias for noise limiter: standing and controlling, where obtained.
- (b) Delay voltage for A.G.C. (MR5).
- (c) A.G.C. and noise limiter switching.

9.1.6 A.F. amplifier and output stages (V10 and V11)

- (a) Precautions to prevent overload on strong signals,

- limiting resistors and negative feedback.
- (b) Tone control, i.e. treble cutting.

9.1.7 Power supplies (V12)

- (a) Separate smoothing for output valve, reason.
- (b) Distributions of H.T., stabilised voltage to frequency changers only.
- (c) L.T. circuit, use of thermistor, surge limiting.
- (d) Stabilising of voltages, action.

9.1.8 Miscellaneous

- (a) De-sensitising. Energising of RLA/1. Action of RLA/1 and RLB/1 when energised.
- (b) Mains operating voltages and input circuits including mains filter and on/off switch.

9.2 Revision Questions

These questions are grouped under three main headings:-

- A. Those which can be answered directly from the text.
- B. Those requiring more than a mere ability to quote the text; whether it be a knowledge of information contained in the manufacturers manual but not in the text, an ability successfully to apply thought to a problem or to marshal facts, or the possession of some standard radio knowledge.
- C. Specific questions providing an introduction to fault finding.

9.2.1 Section A

(i) The R.F. stages of the receiver contain a number of rejector circuits. On which ranges are these employed and what is their purpose?

(ii) Why is double frequency changing employed on range 2?

(iii) What circuits provide frequency selection on range 2?

(iv) Why is the output from the Cal. Osc. taken to both the input and the output circuits of V3?

(v) Why do external signals normally not interfere with the process of receiver calibration?

(vi) Why is a separate oscillator used in conjunction with the frequency changer V3 and not in conjunction with V5?

(vii) Why is the bias to V7 changed when the bandwidth is altered?

- (viii) How is change of bandwidth effected in the three wider positions of the bandwidth switch?
- (ix) Explain how the receiver is protected during the time the transmitter is radiating?
- (x) Explain the action of the balanced demodulator circuit when the receiver is receiving C.W. signals.
- (xi) What is the function of the limiter circuit?
- (xii) How is the delay in the A.G.C. voltage obtained and what is its effect?
- (xiii) Why is the A.G.C. voltage applied only partially to V1 but fully to V2?
- (xiv) Explain the action of the magnetostrictive filter in the receiver.
- (xv) With the aid of a schematic diagram explain the action of the noise limiter.
- (xvi) Explain the action of the calibrating circuit arrangements.
- (xvii) Explain the action of the A.G.C. system.
- (xviii) Explain the action of the R.F. gain control.
- (xix) Explain the action of the desensitising system employed in the receiver.
- (xx) Write a short account of the audio frequency amplifiers and power output stage in the receiver.

9.2.2 Section B

- (i) Explain why the magnetostrictive unit is magnetically polarised.
- (ii) Calculate the approximate length of rod which would be needed for a magnetostrictive unit for 30 kc/s.
- (iii) Draw a graph showing, approximately, how you would expect the resistance of a thermistor to vary with temperature.
- (iv) List as many as possible of the methods employed in the receiver to improve frequency stability.
- (v) Explain how you would use the "Calibrator" facility to pre-tune the receiver to a station known to operate on a frequency of 12.264 Mc/s.
- (vi) Sketch a suitable block diagram and use it to explain what is happening in the receiver when the calibration process is carried out.
- (vii) Explain how to set-up the receiver for bandspreading in one of the marine H.F. bands.

- (viii) Why is decoupling necessary?
- (ix) Why are two intermediate frequencies used on ranges 6 to 10.
- (x) Explain carefully how the fine tuning control in the circuit of V5 can be used to reduce interference by a station on a frequency close to that of the wanted station.
- (xi) Why must a B.F.O. be employed in the receiver?
- (xii) Why is one of the diodes in the balanced demodulator unit rendered inoperative when it is desired to receive 'phone signals.?
- (xiii) What is the meaning of the word "delay" as applied to A.G.C. systems and why is it often employed?
- (xiv) Explain how the smoothing of a power supply is effected by use of an LC combination.
- (xv) Draw a block diagram of the complete receiver including all essential stages and give a brief description of the function of each.
- (xvi) Explain carefully how it is that the limiter circuit employed shifts the voltage datum level as between input and output (as for instance in Fig.34).
- (xvii) The battery voltage of the circuit of Fig.30 being taken as 10 volts, sketch approximate input and output wave shapes when the input is a sine wave of peak value (a) 5 volts and (b) 15 volts.
- (viii) Why are the I.F. transformers screened?
- (vix) Sketch a simplified diagram to show what happens in the affected parts of the circuit when a pair of headphones is plugged into one of the 'phone sockets.
- (xx) Give as many reasons as you can why the gain of the receiver is distributed between various sections of the receiver - R.F., I.F. etc. - instead of being concentrated in one of these sections.

9.2.3 Section C

State with reasons, what would be the probable effect on the performance of the receiver if the following faults occurred:-

- (i) R76 became open circuited.
- (ii) R69 became open circuited.
- (iii) R32 became open circuited.
- (iv) R21 became short circuited.
- (v) R9 became open circuited.

- (vi) C119 became short circuited.
- (vii) C124 became short circuited.
- (viii) C145 became short circuited.
- (xi) R2 became open circuited.
- (x) C21 became short circuited.

APPENDIX 1

Magnetostriction

Ferromagnetic materials such as iron, nickel, cobalt and alloys of these metals undergo a change of dimensions when subject to a change of magnetic state. This effect, which is reversible, is known as the magnetostrictive effect. The change in dimensions takes place along the same line as that of the magnetic force but is normally independent of the sense of the magnetic field.

Suppose that a rod of magnetostrictive material is placed in a coil (Fig.22) when a A.C. is applied to the coil the changes in the magnetic state will cause the rod to contract and expand in the direction of the field and hence to vibrate longitudinally.

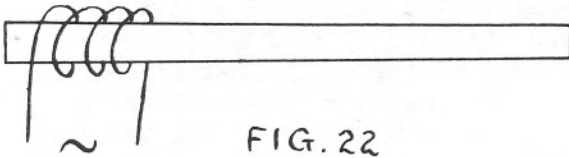

FIG. 22

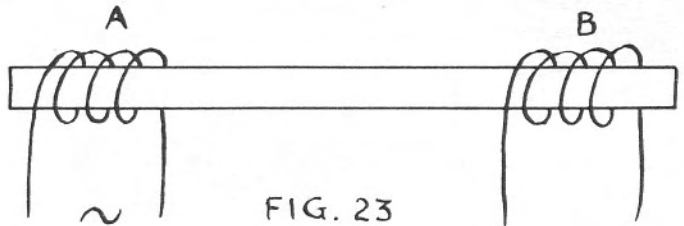

FIG. 23

If two coils are arranged as in Fig. 23 then longitudinal changes in dimension caused by an A.C. input to coil "A" will create a changing magnetic field at "B" which will induce E.M.F. into coil "B". It should be noted that, in the absence of any precautions, the frequency of the output from "B" will be twice that of the input to "A", since the changes in dimensions are independent of the sense of the magnetic field; thus a positive half cycle at the input will cause the rod to expand and then return to normal, i.e. a complete cycle of operations. The succeeding negative half cycle of the input to "A" will cause another, exactly similar cycle in the change of dimensional state of the rod. To avoid the occurrence of this effect the rod may be magnetically polarised so that the changes which are caused in its magnetic state do not set up a change in magnetic polarity but merely increase or decrease the magnitude of an unvarying polarity; the input and output frequencies will now be the same. The reader will recall that a similar subterfuge is necessary to avoid frequency doubling in the case of telephone receivers.

The magnitude of the output increases with the amplitude of the vibrations. The changes in length are normally of the order of thirty parts in a million but when the rod is made resonant they

increase considerably and become about one part in one thousand; for this reason bars one half wavelength long are commonly employed; the calculation being based on the velocity of sound in the material - about 5000 metres per second.

Since $\lambda = \frac{V}{f}$: the length of the rod is $\frac{\lambda}{2} = \frac{5000}{2f}$ metres.

For the "Atalanta" receiver, $f = 85$ kc/s so that the length of rod is about 0.03 metres, i.e. approximately 3 cms.

If D.C. is passed along the rod while A.C. is applied to the coil "A", Fig. 23, the resultant magnetic field will be a combination of the circular field set up by the D.C. and the longitudinal field due to the coil and, in fact, takes the form of a helical field. The rod expands and contracts in the direction of the helical lines of force and is, therefore, twisted, producing torsional vibrations. In this case the output and input frequencies will always be the same, since the necessary polarisation is effected by the D.C. flowing along the rod. Alternatively, the rod may be permanently magnetised by initially passing a large direct current through it or in cases in which the ohmic resistance of the rod is very large, by passing the direct current through a wire running down the centre of the rod, this being the only practical way of providing the necessary polarisation. An advantage of using a high resistance rod is that eddy current losses are very considerably reduced.

The form of the filter used in the "Atalanta" receiver is shown in Fig. 25; the wire shown runs through the centre of the rod and after the initial magnetisation has been effected is of no further use and is connected to the receiver chassis. Owing to the short length of the rod, unwanted mutual coupling exists between the two coils; the effect of this would be deleterious to the action of the device so it is cancelled by feeding into the output circuit an E.M.F. equal, but in opposite phase, to the E.M.F. due to mutual coupling.

In the "Atalanta" receiver the filter is located between V5 and V6 and appears in Fig. 1 and in the circuit diagram in the manufacturers manual in the form shown in Fig. 24.

The bandwidth obtained in this circuit is about 100 c/s. From a well known relationship the approximate effective circuit Q may be calculated:

$$Q = \frac{f_0}{\Delta f} = \frac{85\,000}{100} = 850$$

f_0 being the resonant frequency, 85 kc/s in this case, and Δf the bandwidth between voltage points which are $\sqrt{2}$ times down from the maximum.

It is instructive and interesting to apply to coil "A", in

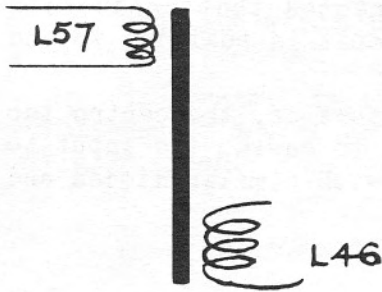

FIG. 24

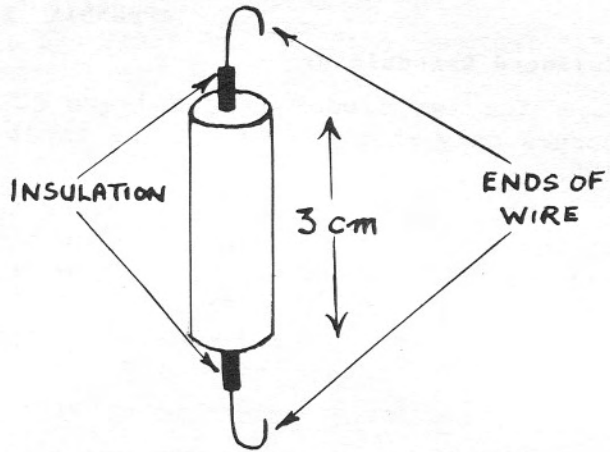

FIG. 25

the "Atalanta" receiver, the output from a signal generator tunable in frequency around 85 kc/s and to observe the output voltage from coil "B" on an oscilloscope. A noteworthy increase in the amplitude of the output takes place as the signal generator is tuned through resonance. If a wobulator is employed the extreme sharpness of the response curve can be seen.

Magnetostrictive bars constitute a very convenient way of obtaining these high effective "Q" values for frequencies between about 5 kc/s and 100 kc/s; outside this range the size of bar is either too large or too small for convenient practical use.

APPENDIX 2

Balanced Demodulator

The two diodes (Fig.26) are so connected that conduction occurs only when end "A" of the input circuit is positive to end "B".

When the B.F.O. is short circuited, that is, the centre tap of the transformer secondary taken direct to earth, the input to each diode is the same, $V_1 = V_2$, so that with similar diodes and balanced circuits $V_3 = V_4$.

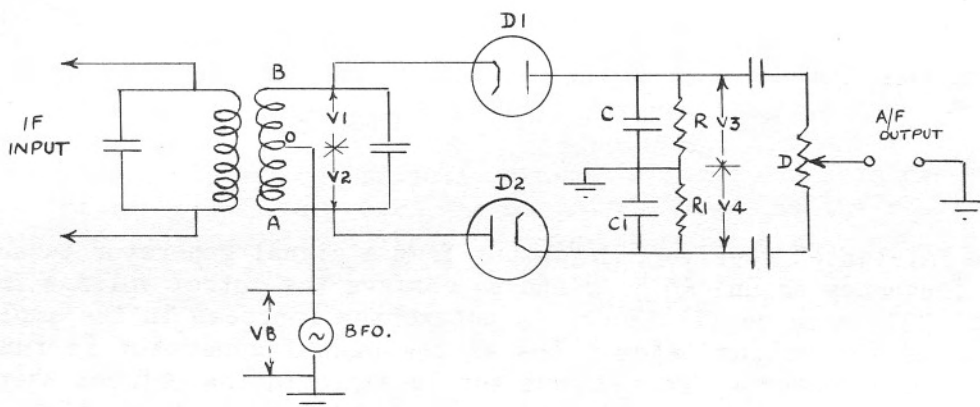

FIG. 26

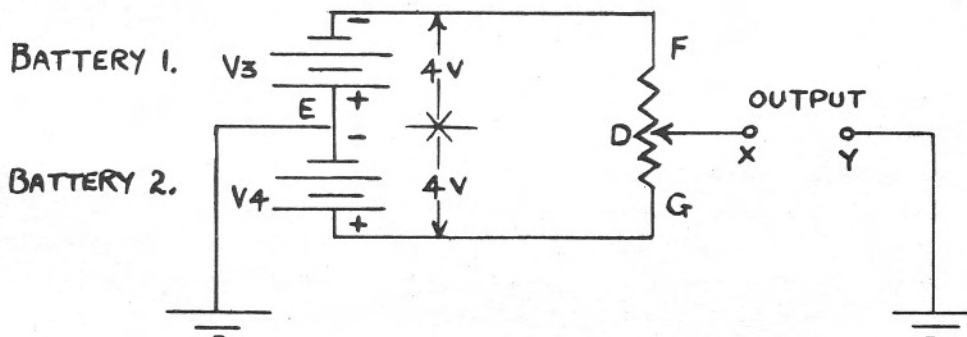

FIG. 27

Consider the output section of Fig. 26 but with batteries substituted for voltages V_3 and V_4 . The circuit is now as shown in Fig.27 which is drawn for the case of equal battery voltages.

When the potentiometer slider is at the end "F", the terminal "X" is at a potential of -4 volts with respect to earth.

When the slider is at the other end "G", the terminal "X" is +4 volts with respect to earth.

When the slider is at the mid-point, "D", the terminal "X" is at earth potential.

In general, if the batteries are not equal, but are assigned voltages V_3 and V_4 respectively (taken as positive downwards), see Fig.28, then:-

$$\text{The voltage at "G" with respect to "F"} = V_3 + V_4$$

$$\text{The voltage at "D" with respect to "F"} = \frac{V_3 + V_4}{2}$$

(The slider "D" being at the mid-position)

The voltage at "D" with respect to "E" is V_3 volts less than this, since V_3 is taken as positive downwards, and is therefore

$$\frac{V_3 + V_4}{2} - V_3 = \frac{V_4 - V_3}{2}$$

Clearly, this is also the voltage across the output terminals at "X" with respect to "Y".

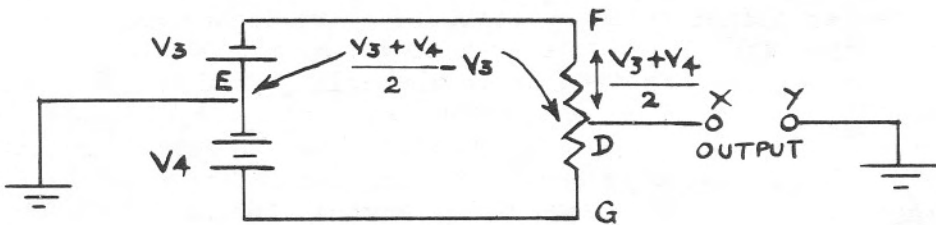

FIG. 28

For the conditions shown in Fig. 29, for instance, the output voltage is

$$\frac{V_4 - V_3}{2} = \frac{2 - 6}{2} = -2$$

meaning that "X" is 2 volts negative to "Y".

If the 6 volt and 2 volt batteries were interchanged the output voltage would become

$$\frac{6 - 2}{2} = 2$$

meaning that "X" is 2 volts positive to "Y".

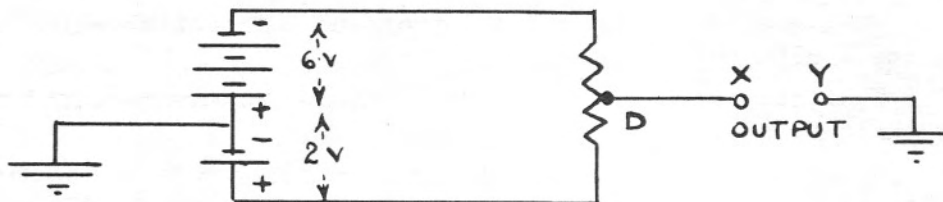

FIG. 29

Thus the magnitude of the output voltage and its polarity depends on the relative battery voltages. The output is zero when the battery voltages are equal.

Now let the batteries, which were introduced in order to simplify the discussion, be replaced by the diode loads (R and R_1 in Fig. 26), across which develop the voltages V_3 and V_4 . The output from the circuit will be zero when $V_3 = V_4$, i.e. when the input to diode D_1 equals that to diode D_2 . Since the circuit is balanced this will always be the case when the B.F.O. is delivering no output; for this reason in the "Atalanta" receiver one of the diodes is switched out of circuit when "phone" reception is required.

For an output to be obtained, the two diodes must have different input voltages; this is achieved by introducing the B.F.O. output between the centre tap of the coil AB and earth. This is indicated in Fig. 30 in which the two diode circuits are shown separately in order to make it clear how the B.F.O. voltage acts in series with the input to each. Consider the polarity of the B.F.O. voltage, V_B , to be as shown, i.e. terminal "0" negative with respect to earth. During conduction V_1 and V_2 will have the polarities indicated so that the voltage applied to D_1 will be V_1 plus V_B while that applied to D_2 will be V_2 minus V_B . On the other hand, of course, when V_B is positive with respect to earth the input to D_1 will be V_1 minus V_B and that to D_2 will be V_2 plus V_B . In fact, since A and B are at opposite ends of the transformer winding the voltages at these two points, with respect to O , will always be of opposite polarity; consequently the B.F.O. voltage will always increase the input voltage to one valve and, at the same time, reduce it to the other. Thus V_3 , Fig. 30, will increase when V_4 reduces and vice versa.

The variations of V_3 and V_4 will occur at a frequency which is equal to the difference between the frequencies of the B.F.O. and the signal input (see Fig. 31). The amplitude of the B.F.O. voltage is, in fact, considerably greater than that of the signal so that the form of the wave shapes is much as shown.

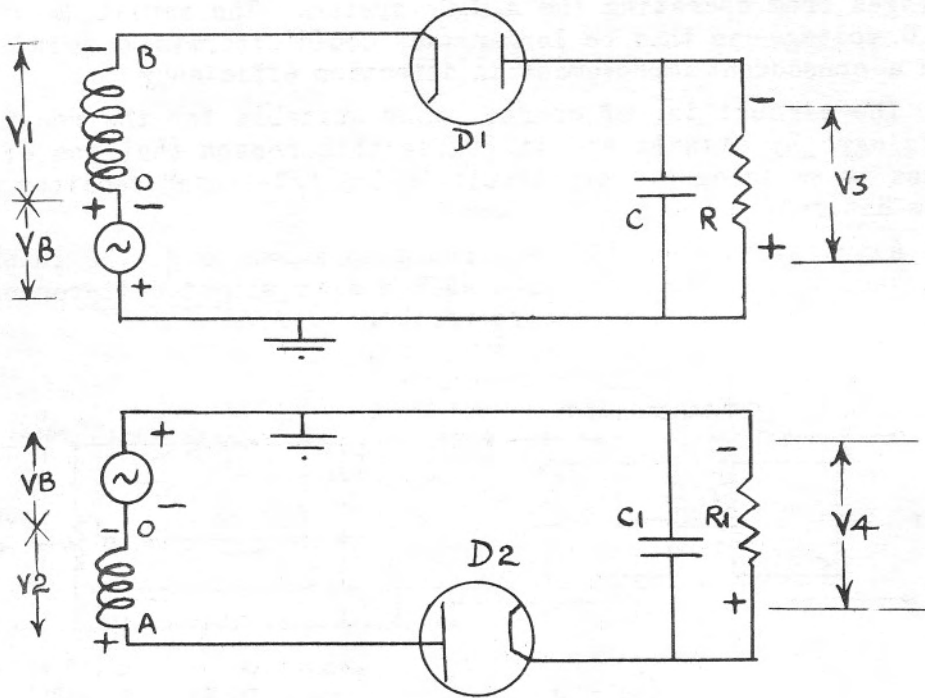

FIG. 30

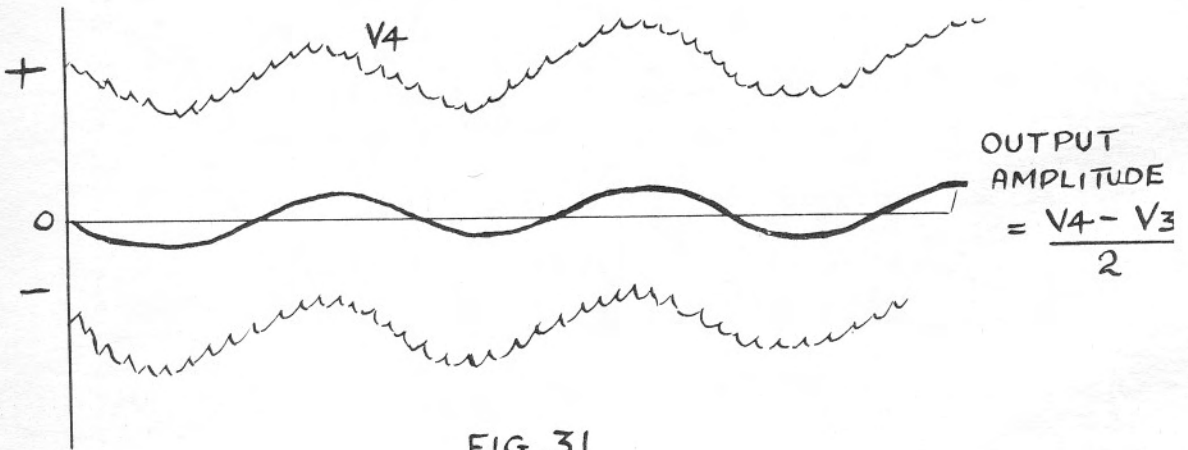

FIG. 31.

This form of circuit places the diodes, in series with their loads, across the tuned input circuit; consequently the damping of the tuned circuit is less than with a single diode. The introduction of the B.F.O. voltage into the centre of the coil prevents pulling and locking to preceding circuits and also prevents B.F.O.

voltages from operating the A.G.C. system. The amplitude of the B.F.O. voltage can thus be larger than could otherwise be permitted, with a consequent improvement in detection efficiency.

The circuit is, of course, only suitable for the reception of telegraphy signals and it is for this reason that one of the diodes is switched out of circuit in the "Atalanta" receiver when it is desired to receive telephony.

A practical form of the circuit is shown in Fig.32 in which R is variable so that any unbalance due to slight differences in valves and components may be corrected.

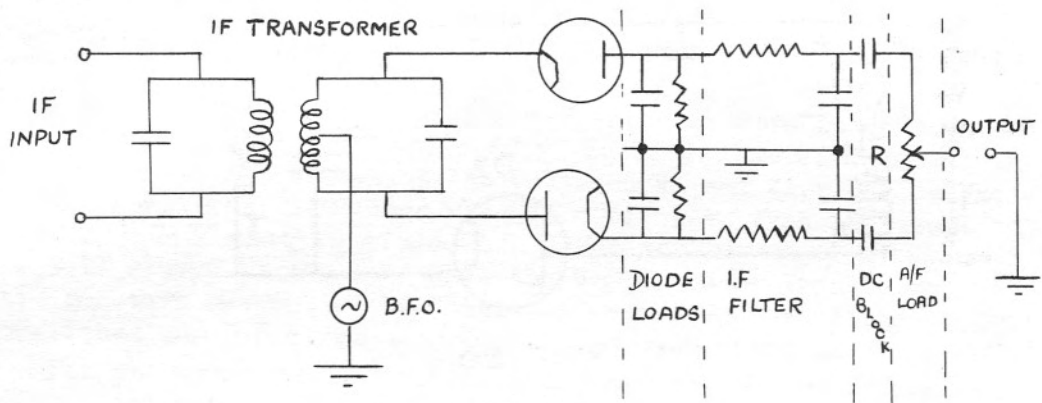

FIG. 32

Noise Limiter

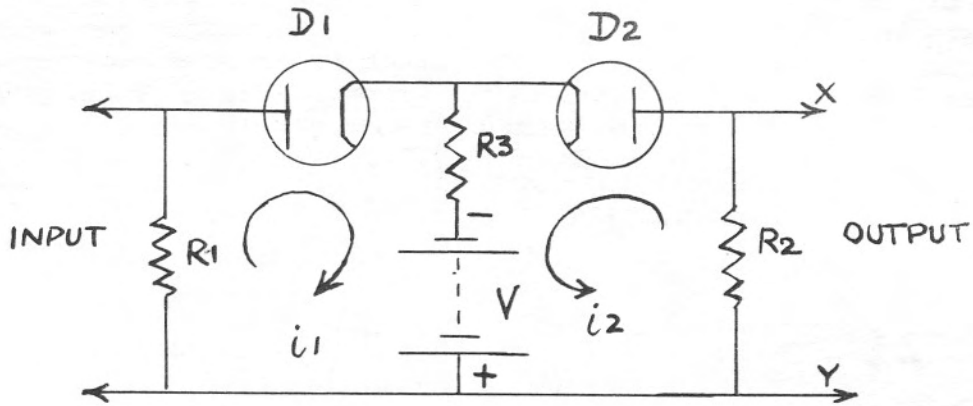

FIG. 33

The object of the circuit is to reduce the amplitude of unwanted noise voltages to a level not greater than that of the wanted signal voltage.

In general, static noise is in the form of large amplitude, short duration pulses. The circuit is designed to operate at A.F. following the detector output and to clip or limit the peak value of all signals above a given level which are applied to its input.

Consider Fig.33. Under no-signal conditions the battery causes the currents i_1 and i_2 to flow. As these currents are constant the output voltage is zero, i.e. there is no A.F. component across R_2 . Suppose an input is now applied of such polarity as to make the anode of D_1 positive; i_1 will increase thus causing both cathodes to become more positive. R_3 is large compared with the resistance of the diodes, hence any voltage drop caused by i_1 or by i_2 will virtually be developed completely across R_3 and not across the diodes. It follows that as soon as the input has risen to a magnitude as large as that of the battery voltage V , D_2 will cut off and there will be no output for all input voltages of greater magnitude.

If the input causes D_1 to go negative than the current i_1 will fall so that the cathodes will become less positive. As a result D_2 will conduct more heavily and the resultant voltage drop

across R3 (positive to the cathodes) will encourage the current in D1 to diminish still further and D1 soon becomes cut-off. As in the previous case, the voltage at which cut off occurs depends on the value of the voltage of the battery, V.

Thus if the input signal is greater than the battery voltage, and either positive or negative, cut off takes place in one of the valves and there is no output (see Fig.34). Note that the output voltage, "X" with respect to "Y", cannot be positive because the diode D2 will not permit current to reverse in R2, so that although the input may be a voltage based on a zero datum line, the output is based on a negative datum of $-V$ volts, where V is the battery voltage.

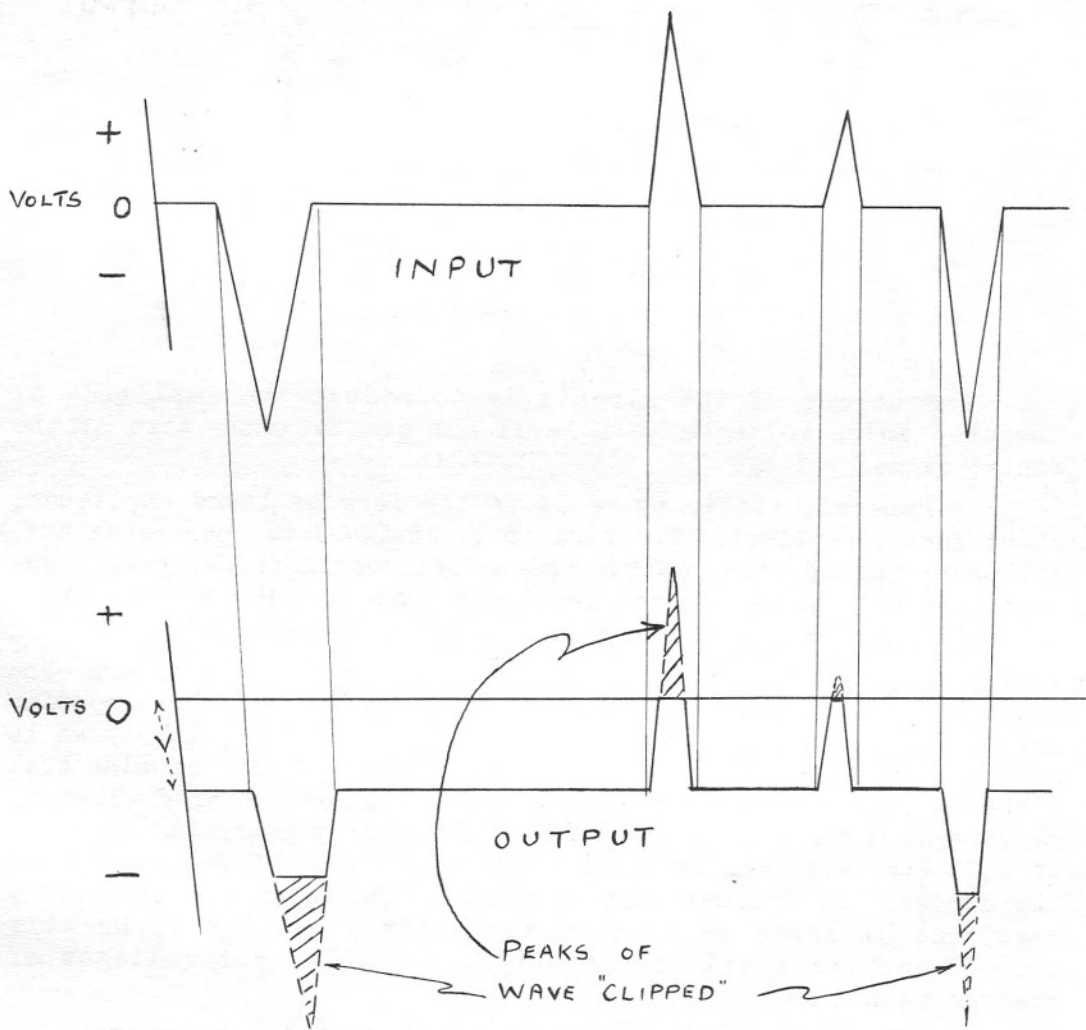

FIG. 34

It would be clearly undesirable to have to adjust the level of battery voltage to suit each level of signal voltage consequently, in practical circuits, the battery is replaced by a diode detector (D3 in Fig.35) and a CR network which produces, from I.F. input, a voltage at the junction of R3 and R4, with respect to earth, which varies with the mean carrier amplitude. The CR network, C5R5, C4R4, has a time constant of about one tenth of a second, which is short enough to permit the voltage to vary in accordance with changes in mean level of I.F. input but not short enough to permit variations in sympathy with modulation or with short bursts of static etc.

Thus signals of smaller amplitude than the mean carrier amplitude are unaffected but peaks of interference of greater amplitude are "clipped".

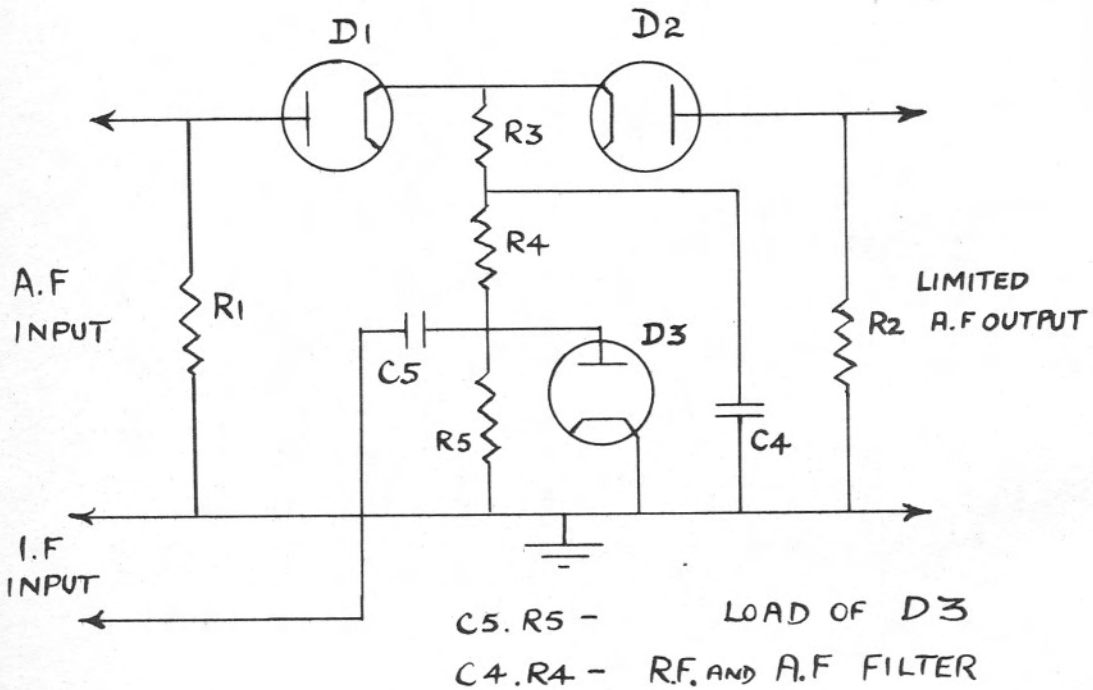

FIG. 35

K4XL's **BAMA**

This manual is provided **FREE OF CHARGE** from the "BoatAnchor Manual Archive" as a service to the Boatanchor community.

It was uploaded by someone who wanted to help you repair and maintain your equipment.

If you paid anyone other than BAMA for this manual, you paid someone who is making a profit from the free labor of others without asking their permission.

You may pass on copies of this manual to anyone who needs it. But do it without charge.

Thousands of files are available without charge from BAMA. Visit us at <http://bama.sbc.edu>