



HiPace 300 C Turbopump

Operating Instructions



FOR SALES AND SERVICE PLEASE CALL:

PTB SALES T :: 866.332.0500
F :: 626.334.2151
www.ptbsales.com

DATE SERVICED: _____

VIEW OUR INVENTORY

Table of contents

1	About this manual	3
1.1	Validity	3
1.2	Conventions	3
2	Safety	5
2.1	Safety precautions	5
2.2	Protective equipment	6
2.3	Proper use	6
2.4	Improper use	7
3	Transport and storage	8
3.1	Transport	8
3.2	Storage	8
4	Product description	9
4.1	Product identification	9
4.2	Function	9
4.3	Range of application	10
5	Installation	11
5.1	Set-up	11
5.2	Preparatory work	11
5.3	Assembly	11
5.4	Connections to the turbopump	15
6	Operation	22
6.1	Commissioning	22
6.2	Operation modes	22
6.3	Function description	23
6.4	Monitoring of the operation conditions	24
6.5	Switching off and venting	24
7	Maintenance / replacement	25
7.1	Maintenance intervals and responsibilities	25
7.2	Replacing the operating fluid reservoir	25
7.3	Replacing the electronic drive unit	27
8	Decommissioning	28
8.1	Shutting down for longer periods	28
8.2	Re-starting	28
8.3	Disposal	28
9	Malfunctions	29
9.1	Rectifying malfunctions	29
10	Service	30
11	Spare parts HiPace 300 C	31
12	Accessories	32
12.1	HiPace 300 C, 24 V DC	32
12.2	Differences at HiPace 300 C, 48 V DC	33
13	Technical data and dimensions	34
13.1	General	34
13.2	HiPace 300 C, 24 V DC	34
13.3	Differences at HiPace 300 C, 48 V DC	35
13.4	Dimensions	36
	Declaration of conformity	37

1 About this manual

1.1 Validity

This operating manual is for customers of Pfeiffer Vacuum. It describes the functioning of the designated product and provides the most important information for safe use of the unit. The description follows applicable EU guidelines. All information provided in this operating manual refer to the current state of the product's development. The documentation remains valid as long as the customer does not make any changes to the product.

Up-to-date operating instructions can also be downloaded from www.pfeiffer-vacuum.net.

Applicable documents

HiPace 300 C	Operating instructions
Operating instructions "Electronic drive unit TC 400"	PT 0203 BN*
Declaration of conformity	Part of this document

*also available via www.pfeiffer-vacuum.net

For information about other certifications, if applicable, please see the signet on the product or:

- www.tuvdotcom.com
- TUVdotCOM-ID 0000021320

1.2 Conventions

Safety instructions

The safety instructions in Pfeiffer Vacuum operating manuals are the result of risk evaluations and hazard analyses and are oriented on international certification standards as specified by UL, CSA, ANSI Z-535, SEMI S1, ISO 3864 and DIN 4844. In this document, the following hazard levels and information are considered:

DANGER
<p>Immediate danger Death or very severe injuries can occur.</p>
WARNING
<p>Possible danger Injuries or severe property damages can occur.</p>
CAUTION
<p>Possible danger Injuries or property damages can occur.</p>
NOTE
<p>Command or note Command to perform an action or information about properties, the disregarding of which may result in damage to the product.</p>

Pictograph definitions



Prohibition of an action or activity in connection with a source of danger, the disregarding of which may result in serious accidents.



Warning of a displayed source of danger in connection with operation of the unit or equipment.



Command to perform an action or task associated with a source of danger, the disregarding of which may result in serious accidents.

Instructions in the text

→ Work instruction: here you have to do something.

Abbreviations used

DCU:Display and operating unit
HPU:Handheld programming unit
TC:Electronic drive unit for turbopump
TPS:Mains pack

Symbols used

The following symbols are used consistently throughout the diagrams:

- Ⓜ High vacuum flange
- Ⓦ Fore-vacuum flange
- ⚡ Electric connection
- ⊗ Cooling water connection
- ⓕ Venting connection
- Ⓢⓖ Sealing gas connection

2 Safety

2.1 Safety precautions



NOTE

Duty to inform

Each person involved in the installation, operation or maintenance of the vacuum pump must read and observe the safety-related parts of these operating instructions.

→ The operator is obligated to make operating personnel aware of dangers originating from the vacuum pump, the pumped medium and the entire system.



NOTE

Installation and operation of accessories

Pfeiffer Vacuum pumps can be equipped with a series of adapted accessories. The installation, operation and maintenance of connected devices are described in detail in the operating instructions of the individual components.

→ For information on order numbers of components, see "Accessories".
→ Use original accessory parts only.



NOTE

Checking the safety system against excess rotation speed

To provide the functioning of the integrated safety system for avoiding excess rotation speed, the pump must run-up from the standstill at least once a year.

→ Switch off the pump and await the complete standstill (rotation speed = 0 Hz).
→ Run-up the pump according to this operating instructions.



WARNING

Danger - Electrical installation

Safe operation after installation is the responsibility of the operator.

→ Do not independently modify or change the pump and electrical equipment.
→ Make sure that the system is integrated in an emergency off safety circuit.
→ Consult Pfeiffer Vacuum for special requirements.



WARNING

Danger of electric shock

In case of defect, the parts connected to the power supply are under voltage.

→ Always keep the mains connection freely accessible so you can disconnect it at any time.

- Do not expose any body parts to the vacuum.
- Observe all safety and accident prevention regulations.
- Regularly check the proper observance of all safety measures.
- **Power supply:** The turbopump power supply must apply to the requirements of double insulation between mains input voltage and operating voltage according to the regulations of IEC 61010 and IEC 60950. Therefore Pfeiffer Vacuum recommends to use exclusively original-power packs and -accessories. Only in this case Pfeiffer Vacuum is able to guarantee the compliance of the European and North American guidelines.
- A safe connection to the protective earthing conductor (PE) is recommended (protection class III).
- Do not loosen any plug connection during operations.
- Wait for the rotor to reach standstill before performing work on the high vacuum flange.

- Keep leads and cables well away from hot surfaces (> 70 °C).
- Never fill or operate turbopump with cleaning agent.
- Do not operate the turbopump with open high vacuum flange.
- Do not carry out any unauthorized modifications or conversions to the pump.
- When returning the turbopump observe the shipping instructions.

2.2 Protective equipment

Determined situations concerning the handling of vacuum pumps require wearing of personal protective equipment. The owner, respectively the employer are obligated to provide adequate equipment to any operating persons.



DANGER
<p>Danger to health by hazardous substances during maintenance or installation</p> <p>Depending on the process vacuum pumps, components or operating fluids can be contaminated by toxic, reactive or radioactive substances.</p> <p>→ Wear adequate protective equipment during maintenance and repairs or in case of reinstallation.</p>



WARNING
<p>Risk of injury through falling objects</p> <p>When transporting vacuum pumps by hand, there is a danger through loads slipping and falling down.</p> <p>→ Carry small and mid-size vacuum pumps two-handed.</p> <p>→ Carry vacuum pumps > 20 kg by a suitable lifting device.</p> <p>→ Wear safety shoes with steel toe cap according to directive EN 347.</p>



CAUTION
<p>Risk of injury through hot surfaces</p> <p>Vacuum pumps can become hot during operation.</p> <p>→ Allow the pump to cool before maintenance and repairs.</p> <p>→ If necessary wear protective gloves according to directive EN 420.</p>



CAUTION
<p>Risk of injury through sharp edges</p> <p>Rotor and stator disks of turbopumps have very sharp edges.</p> <p>→ Before any working wait for the complete standstill of the pump.</p> <p>→ Do not reach in the high vacuum flange.</p> <p>→ If necessary wear protective gloves according directive EN 420.</p>

2.3 Proper use



NOTE
<p>CE conformity</p> <p>The manufacturer's declaration of conformity becomes invalid if the operator modifies the original product or installs additional components.</p> <p>→ Following installation into a plant and before commissioning, the operator must check the entire system for compliance with the valid EU directives and reassess it accordingly.</p>

- The vacuum pump may only be used to generate a vacuum.
- Only operate the turbopump with an approved backing pump.

2.4 Improper use

Improper use will cause all claims for liability and warranties to be forfeited. Improper use is deemed to be all use for purposes deviating from those mentioned above, especially:

- Pumping of explosive media.
- Pumping of corrosive gases without using of sealing gas.
- Pumping of condensing vapors.
- Pumping of liquids.
- Pumping of dusts without using of sealing gas.
- Operation with improper high gas throughput.
- Operation with improper high fore-vacuum pressures.
- Operation with improper gas mode.
- Operation with improper high levels of insulated heat input.
- Venting with improper high venting rates.
- Use of the vacuum pump to generate pressure.
- The operation of the devices in potentially radioactive areas.
- Operation in potentially explosive areas.
- The operation of the devices in systems where the turbopumps are subjected to impact-like stress and vibrations or the effect of periodically occurring forces.
- The use of accessories, which are not named in this manual.

warranty seal

PFEIFFER  VACUUM

NOTE

Closure seal

The product is sealed at the factory. Damaging or removal of a closure seal leads to the loss of liability and warranty entitlements.

→ Do not open the product within its warranty period!

→ For process-related shorter maintenance intervals please contact the Pfeiffer Vacuum Service.

3 Transport and storage

3.1 Transport

- Reuse the transport container. Vacuum pumps should be transported or shipped in the original packing only.
- Only remove the protective covers from the high vacuum and the fore-vacuum side immediately before connection.
- Keep the original protective covers.
- Always transport the turbopump in an upright position.

3.2 Storage

- Close the flange openings by using the original protective covers.
- Close further connection ports by using the corresponding protective covers.
- Store the pump only indoors at temperatures between -25 °C and +55 °C.
- In rooms with moist or aggressive atmospheres, the pump must be airproof shrink-wrapped in a plastic bag together with a bag of desiccant.

4 Product description

4.1 Product identification

Pump types

The product designations of Pfeiffer vacuum turbomolecular pumps are self-explanatory and permit conclusions about the different versions. The product designation consists of a family designation (1), the size (2), which is oriented on the pumping speed, and if applicable the additional properties (3) of the pump.

HiPace⁽¹⁾ 300⁽²⁾C⁽³⁾

1. Family designation	2. Model designation	3. Property designation
HiPace	300 = Model designation of the pump related to its pumping speed class	none = Standard version U = Upside-down installation orientation C = Corrosive gas version P = Process M = Active magnetic bearing T = Temperature management system

Pump features

Characteristics	HiPace 300 C		
HV flange	DN 100 ISO-K	DN 100 ISO-F	DN 100 CF-F
Flange material	Aluminium	Aluminium	Stainless steel

To correctly identify the product when communicating with Pfeiffer Vacuum, always have the information from the rating plate available.



Fig. 1: Example for a rating plate

Variants

- HiPace 300 C with TC 400 and 24 VDC \pm 5 %
- HiPace 300 C with TC 400 and 48 VDC \pm 5 %

Scope of delivery

- Turbopump with electronic drive unit
- Mating plug for the connection "*remote*" on the TC 400.
- Protective cover for the high vacuum and the fore-vacuum flange
- Operating instructions

4.2 Function

The turbopump HiPace 300 C forms a complete unit together with the electronic drive unit TC 400. For the voltage supply only Pfeiffer Vacuum power supplies may be used (e.g. TPS or DCU).

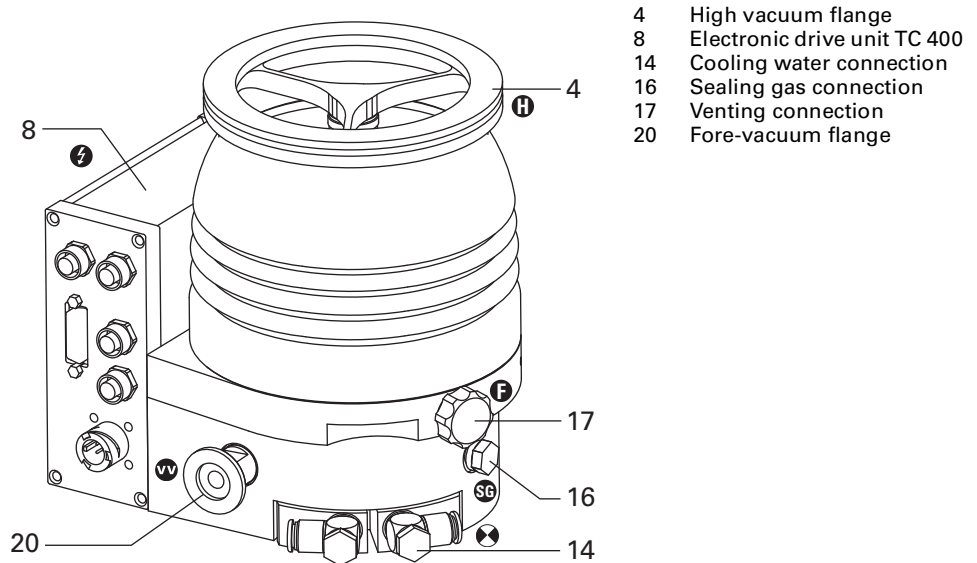

Fig. 2: View of HiPace 300 C with TC 400

Cooling

- Water cooling
- Air cooling (optional)

In the case of excess temperature the electronic drive unit reduces the drive power automatically. Depending on the application and the HiPace different cooling variants are selectable.

Rotor bearing

Hybrid bearing Turbopump

- High vacuum side: maintenance-free permanent magnetic bearing.
- Fore-vacuum side: ceramic ball bearing.

Drive

Electronic drive unit TC 400

4.3 Range of application

The pump HiPace 300 C must be installed and operated under the following ambient conditions:

Installation location	weather protected (indoors)
Protection category	IP 54
Protection class	III
Temperature	+5 °C to +35 °C with air cooling +5 °C to +40 °C with water cooling
Relative humidity	max. 80 %, at T ≤ 31 °C, up to max. 50% at T ≤ 40 °C
Atmospheric pressure	77 kPa - 106 kPa
Installation altitude	2000 m max.
Degree of pollution	2
Permissible surr. magnetic field	≤5.5 mT
Overvoltage category	II
Connection voltage TC, depending on the variants	24 VDC ±5% 48 VDC ±5%

5 Installation



DANGER

Danger from the turbopump being torn-off

In case of sudden blocking of the rotor, torques of up to 2000 Nm can occur, which can lead with incorrect attachment to tearing the turbopump off. The energy released thereby can hurl the entire pump or fragments from their inside around the area. This can cause severest injuries (possibly resulting in death) and large property damage.

- Precisely follow installation instructions.
- Only use Pfeiffer Vacuum original components (accessories) for installation.



NOTE

Installation and operation of accessories

Pfeiffer Vacuum pumps can be equipped with a series of adapted accessories. The installation, operation and maintenance of connected devices are described in detail in the operating instructions of the individual components.

- For information on order numbers of components, see "Accessories".
- Use original accessory parts only.

5.1 Set-up

When installing the pump, observe the following conditions:

- The ambient conditions specified for the area of use.
- When using a casing heating and a water cooling unit the temperature of the connected flange of the vacuum chamber must not exceed 120 °C.
- The pump may be fastened to the floor only after consultation with Pfeiffer Vacuum.
- It is not allowed to operate the device in systems where impact-like stresses and vibrations or periodically forces occur.

5.2 Preparatory work

- Ensure sufficient cooling for the turbopump.
- Where magnetic fields > 5.5 mT are involved, a suitable shielding must be used. Check installation location and consult Pfeiffer Vacuum if needed!
- The maximum permissible rotor temperature for the turbopump is 110 °C. If high temperatures arise for process reasons, the radiated heat input must not exceed 2.4 W. Install suitable screening sheets, if necessary (design information on request).

5.3 Assembly

- Ensure the greatest possible cleanliness when installing any high vacuum parts. Unclean components prolong the pump-down time.
- All flange components must be grease-free, dust-free and dry at installation.
- The operating fluid reservoir is already installed and filled for the turbopump HiPace 300 C.

Earthquake safety

An earthquake can result in contact with the safety bearings. All forces occurring hereby are safely absorbed by the properly installed flange connections.

- The vacuum chamber must be secured by the customer against shifting and tipping.

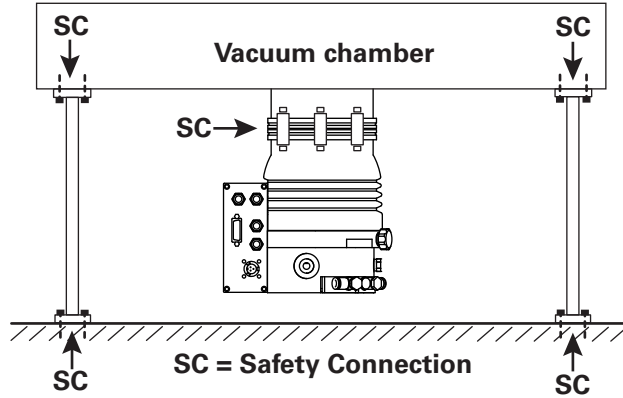

Fig. 3: Example: How to secure against shifting and tipping by external tremors

Use of a splinter shield or protection screen

The installation of a Pfeiffer Vacuum centering ring with splinter shield or protection screen in the high vacuum flange protects the turbopump against foreign bodies coming from the chamber. The volume flow rate is reduced.

	Reduced pumping speed in %			
	H ₂	He	N ₂	Ar
Splinter shield DN 100	5	7	24	24
Protection screen DN 100	2	2	10	8

Vibration damper



DANGER

Danger from the turbopump and vibration damper being torn-off

In case of sudden blocking of the rotor, an applied vibration damper cannot compensate any of the occurring forces. There is a danger of the turbopump being torn-off and thereby resulting in severe injuries and property damages. Applicable safeguards must be taken to compensate possible occurring torques.

- Definitely consult with Pfeiffer Vacuum.
- Do not exceed the max. permissible temperature at the vibration damper (100° C).

Mounting orientation



NOTE

Observe type-specific mounting orientations!

Impermissible mounting orientations result in contamination of the process vacuum or damage to the pump.

- Pay attention to the properties code after the model designation on the name plate!
- Observe the pictographs on the pump housing!

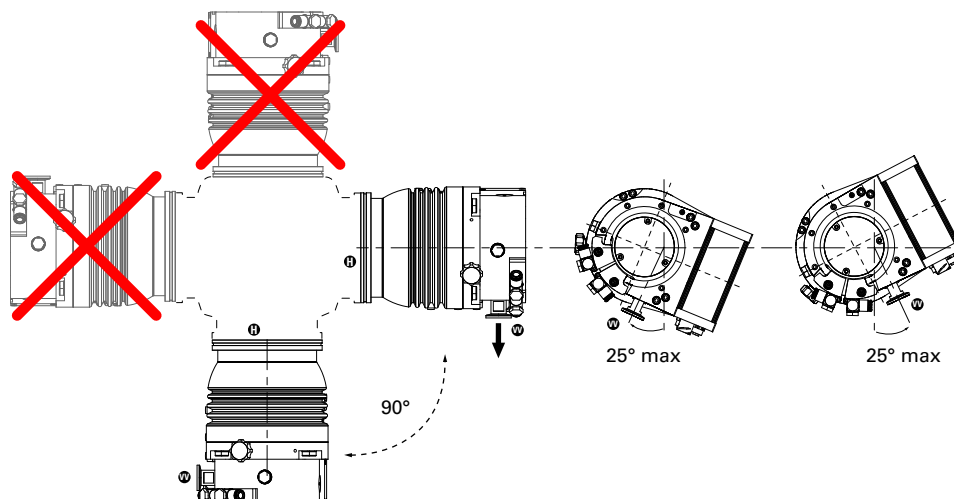

Fig. 4: Permissible mounting orientations for HiPace 300 C

- To avoid contamination via the fore-vacuum line when using oil-sealed backing pumps the fore-vacuum flange should always point vertically downward ($\pm 25^\circ$).
- Support pipes in front of the vacuum pump or remove them. No force from the pipe system may be exerted on the fixed pump.

The maximum axial loading capacity of the high vacuum flange is 500 N (equals 50 kg). A one-sided load on the high vacuum flange is not permitted.

Installing the high vacuum flange

If the rotor is suddenly blocked, the torques arising from the system and the high vacuum flange must be absorbed. Only the components designated as accessory can be used to fasten the turbo pumps to the high vacuum flange. The components for installing the turbo pumps are special designs of Pfeiffer Vacuum. Observe the minimum strength of 170 N/mm^2 for the flange material.



DANGER

Danger to life - impermissible fastening

Twisting or tearing-off is possible in case the rotor is suddenly blocked due to the fastening of pumps on a vacuum chamber with different flange variants.

- The combination of different flange types is impermissible in any case.
- Pfeiffer Vacuum will not accept any liability for all damages resulting from impermissible fastening.



NOTE

Observe shape tolerances for the counter flange!

Unevennesses of the customer supplied counter flange can lead to warping of the pump casing despite proper fastening. Leakiness and negative running characteristics can be the result.

- Do not exceed an evenness of max. 0.05 mm for the whole surface.



NOTE

Mounting of ISO flanges

If the rotor suddenly blocks the connection of high vacuum flanges of types ISO-KF or ISO-K can lead to twisting despite proper installation.

- The tightness of the high vacuum flange is not at risk thereby.

Installation of ISO-K flange with ISO-K flange

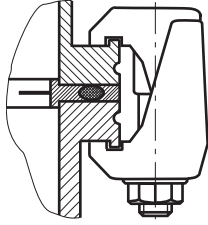

For the installation of the flange connections the following components are available:

- The valid mounting kit of the Pfeiffer Vacuum accessories programme.
 - A protection screen or splinter shield can optionally be used.
- Mind that the sealing surfaces are not damaged.
- Connect the flanges according to the drawing and with the component parts of the mounting kit.
- Use the required number of **6** claw clamps.
- Tighten the claw clamps crosswise in three steps.
- Tightening torque: 5, 15, 25 ± 2 Nm

Installation of ISO-F with ISO-F flange

The connection types for installation of ISO-F to ISO-F flange are "hex screw and blind hole", "stud screw and blind hole" as well as "stud screw and through hole". The following elements are required:

- The valid mounting kit of the Pfeiffer Vacuum accessories programme.
- A protection screen or splinter shield can optionally be used.

Hexagon screw and blind hole

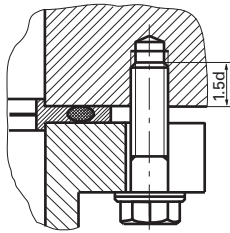

- Mind that the sealing surfaces are not damaged.
- Connect the flanges according to the drawing and with the component parts of the mounting kit.
- Use the required number of **8** hex screws with washer.
- For a flange material with a strength of > 270 N/mm² screw in the hex screw 1.5 d into the blind hole.
- Tighten the hex screws crosswise in three steps.
- Tightening torque DN 100: 5, 12, 22 ± 2 Nm

Stud screw and blind hole

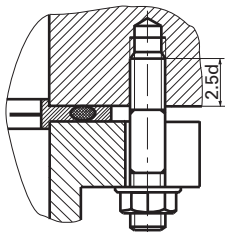

- Mind that the sealing surfaces are not damaged.
- Connect the flanges according to the drawing and with the component parts of the mounting kit.
- Use the required number of **8** stud screws and nuts.
- For a flange material with a strength of 170 - 270 N/mm² screw in the hex screw 2.5 d into the blind hole.
- Tighten the nuts crosswise in three steps.
- Tightening torque DN 100: 5, 12, 22 ± 2 Nm

Stud screw and through hole

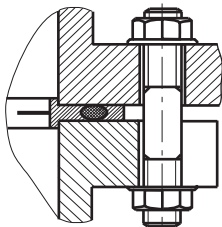

- Mind that the sealing surfaces are not damaged.
- Connect the flanges according to the drawing and with the component parts of the mounting kit.
- Use the required number of **8** stud screws and nuts.
- Tighten the nuts crosswise in three steps.
- Tightening torque DN 100: 5, 12, 22 ± 2 Nm

Installation of CF-flanges



NOTE

Preservation of sealing capacity

Observe the following to preserve sealing capacity:

- Touch seals only with gloves.
- Make sure sealing lips are undamaged.

The connection types for installation of CF to CF flange are "stud screw and blind hole" as well as "hex screw and through hole". The following elements are required:

- The valid mounting kit of the Pfeiffer Vacuum accessories programme.
- A copper seal
- A protection screen or splinter shield can optionally be used.

Stud screw and blind hole

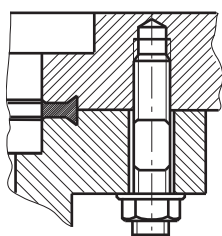

- If used: Insert protective screen or splinter shield with the clamping lugs downward into the high vacuum flange of the turbopump.
- Place the seal exactly in the hollow.
- Connect the flange using **16** stud screws (M8) with washers and nuts and tighten circularly with a torque of 22 ± 2 Nm. After this, check the torque, since flowing of the sealing material may make it necessary to tighten the screws.

Hexagon screw and through hole

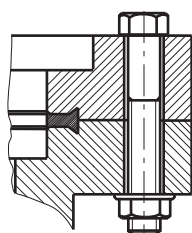

- If used: Insert protective screen or splinter shield with the clamping lugs downward into the high vacuum flange of the turbopump.
- Place the seal exactly in the hollow.
- Connect the flange using **16** hex screws (M8) with washers and nuts and tighten circularly with a torque of 22 ± 2 Nm. After this, check the torque, since flowing of the sealing material may make it necessary to tighten the screws.

5.4 Connections to the turbopump

Electronic drive unit

Turbopumps with integrated electronic drive unit are designed for various applications. Therefore different connection panels are available for the TC 600.

- TC 400 in standard version
- TC 400 PB for Profibus linking
- TC 400 E74 in dependence on specification SEMI E74
- TC 400 DN for DeviceNet linking

Detailed description for function, configuration and operation with the respective connection panel are given in the specific operating instructions for the electronic drive unit.

Connecting the power supply

For voltage supply of the electronic drive unit TC 400, only use original power supplies (e.g. TPS 310 or DCU 310). Use of other power supplies only after consultation with Pfeiffer Vacuum. Connecting cables are available from the Pfeiffer Vacuum accessory programme.



WARNING

Danger of electric shock
 In case of defect, the parts connected to the power supply are under voltage.
 → Always keep the mains connection freely accessible so you can disconnect it at any time.

→ Make sure that the turbopump has the correct supply voltage.

HiPace	VDC	Drive unit	Power supply	Power supply with DCU
HiPace 300 C	24	TC 400	TPS 310/311	DCU 310
HiPace 300 C	48	TC 400	TPS 400/401	DCU 400

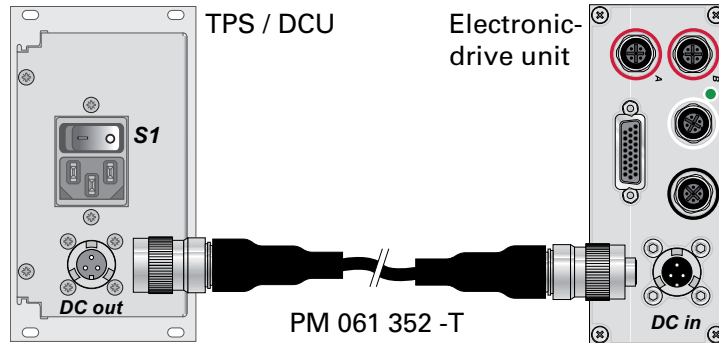

Fig. 5: Connecting the TC 400 to a power supply pack using a Pfeiffer Vacuum cable

- Switch off switch S1 on the mains pack (position "0").
- Insert the connection cable with the socket in the connection "DC in" on the electronic drive unit and close the bayonet lock.
- Insert the connection cable with the plug in the connection "DC out" on the power supply and close the bayonet lock.

Remote plug

The shipment includes a mating plug for the 26-pin connection with the designation "remote" on the TC 400. The mating plug bridges the following connections with the supply voltage (Pin 1), allowing the turbopump to operate without an additional operating unit or remote control:

- Pin 2, Enable venting "on"
- Pin 3, Motor pump "on"
- Pin 4, Pumping station "on"
- Pin 14, Remote access request

→ Place and fix the mating plug on the connection "remote" on the TC 400.



CAUTION

Automatic start
 After bridging the contacts Pin 1, 3, 4, 14 on the connection "remote" or using the mating plug supplied **and** setting up the supply voltage, the turbopump will run up immediately.
 → Switch on the mains supply on the turbo pump immediately before operation.

Accessory connection

Up to 4 accessories can be connected to the electronic drive unit TC 400. M12 sockets with the designation "accessory" are available for this purpose. The accessory connections have been preconfigured at the factory. If the units listed below are connected with the preconfigured connection, they are immediately ready for operation according to the factory settings. It is possible to connect other accessories; to do so, settings must be made on the electronic drive unit.

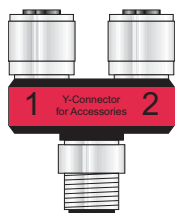

- To connect two units to one accessory connection, use the appropriate Y-Connector from the Pfeiffer Vacuum range of accessories.
- Connect the adapter to the appropriate red-coded connection on the TC 400.
- Settings can be made via the interfaces of the TC 400 (*remote, RS485, Profibus or DeviceNet*).

Accessory connection	Connection with Y-connector	Preset accessory
Accessory A1	Acc. A to Y-1	Air cooling unit
Accessory A2	Acc. A to Y-2	Backing pump
Accessory B1	Acc. B to Y-1	Venting valve
Accessory B2	Acc. B to Y-2	Casing heating unit

Overview of factory preset accessory connections on the TC 400

Connecting the fore-vacuum side

Recommendation: As backing pump, use a dry-compressing vacuum pump or a rotary vane pump from the Pfeiffer Vacuum programme. The backing pump must generate a vacuum pressure of ≤ 1 mbar.



WARNING

Damage to health due to poisonous gases

Process gases can damage health and contaminate the environment.

- Safely lead away the gas emission from the backing pump!
- Observe all safety recommendations of the gas producer.

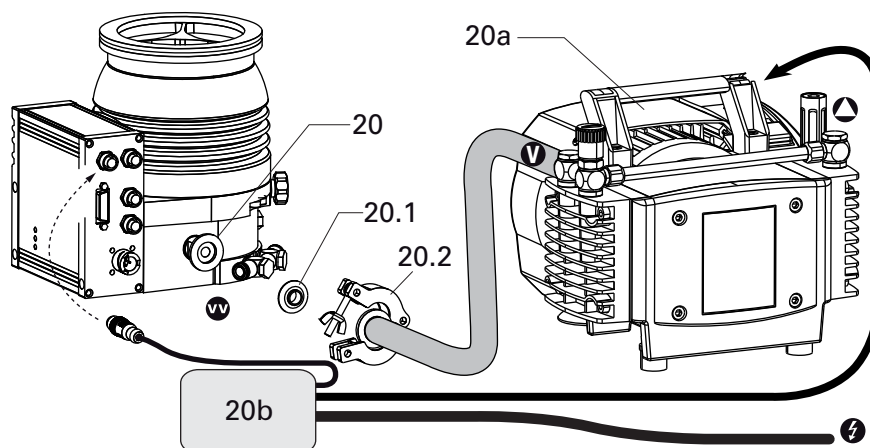

Fig. 6: Connecting the backing pump

- | | | | | | |
|-----|------------------------|------|------------------------|------|---------------|
| 20 | Fore-vacuum connection | 20b | Backing pump relay box | 20.2 | Clamping ring |
| 20a | Backing pump | 20.1 | Centering ring | | |



NOTE

Design of the fore-vacuum connection regarding sudden twisting of the pump

If the rotor suddenly blocks the connection of high vacuum flanges of types ISO-KF or ISO-K can lead to twisting despite proper installation.

- Keep masses small, which can be installed directly to the pump.
- First connect flexible line elements directly to the turbopump, if necessary.
- With rigid pipe connections: Install bellows for attenuation of vibrations in the connection line.
- Connect the fore-vacuum line with small-flange components or threaded hose couplings. Do not narrow the free cross section of the fore-vacuum flange!
- The backing pump is connected electrically via a relay box.
- Plug in and fix the accessory's control lead to the corresponding accessory connection port on the TC 400.
- Default for the backing pump is "accessory A2".

- Establish the mains supply for the relay box according to the accessory operating instructions.
 - Observe the valid supply voltage of the backing pump.

Air cooling

As an option, turbopumps with the electronic drive unit TC 400 may be operated with air cooling up to an ambient temperature of +35 °C.

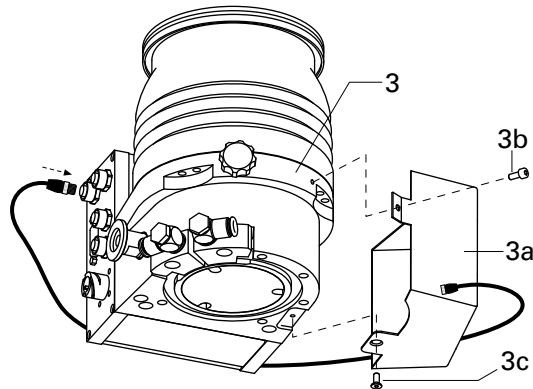

Fig. 7: Connecting the air cooling

3	Pump lower part	3b	Allen head screw
3a	Air cooling unit	3c	Counter sunk screw

- Fix the Pfeiffer Vacuum air cooling unit to the holes of the turbopump using two screws.
- Plug in and fix the accessory's control lead to the corresponding accessory connection port on the TC 400.
- Default for air cooling is "accessory A1".

Venting valve

The Pfeiffer Vacuum venting valve is used for automatic venting in case of shutdown or power failure.

The permissible connection pressure is max. 1.5 bar absolute.

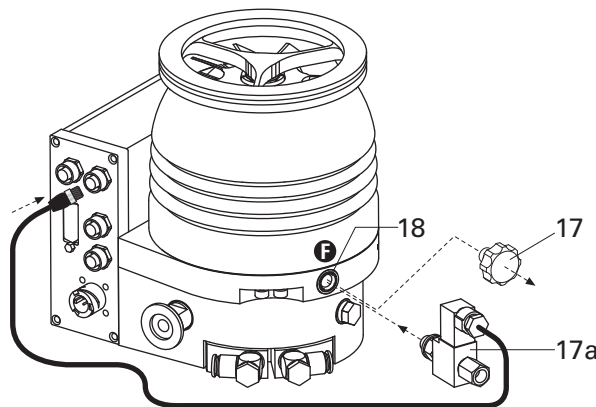

Fig. 8: Connecting the venting valve

18	Seal ring	17	Venting screw	17a	Venting valve
----	-----------	----	---------------	-----	---------------

- Unscrew the venting screw with seal ring from the venting connection.
- Screw in the venting valve with seal ring.
- Plug in and fix the accessory's control lead to the corresponding accessory connection port on the TC 400.
- Default for the venting valve is "accessory B1".
- If necessary install a venting gas supply (e.g. inert gas) to the intake (G 1/8") of the solenoid valve.

Heating jacket

The turbopump and vacuum chamber can be heated to reach the final pressure more quickly. Use of a heating jacket is only permissible for pumps with the high vacuum flange in stainless steel design. The heating duration depends on the degree of contamination as well as the final pressure to be reached and should be at least 4 hours.



CAUTION

Dangerous excess temperatures
 Process-related high temperatures can result in impermissible excess temperatures and thus damage to the turbopump.
 → Always use water cooling when a casing heating is used or when the pump is connected to a heated vacuum chamber.



WARNING

Danger of burns
 High temperatures arise when the turbopump or vacuum chamber are baked out. As a result, there is a danger of burns from touching hot parts, even after the casing heating is switched off!
 → Thermally insulate heating jacket, pump housing and vacuum chamber, if possible during installation.
 → Do not touch heating jacket, pump casing and vacuum chamber during bake out.

- When using a casing heating and a water cooling unit the temperature of the connected flange of the vacuum chamber must not exceed 120 °C.
- The maximum permissible rotor temperature for the turbopump is 110 °C. If high temperatures arise for process reasons, the radiated heat input must not exceed 2.4 W. Install suitable screening sheets, if necessary (design information on request).

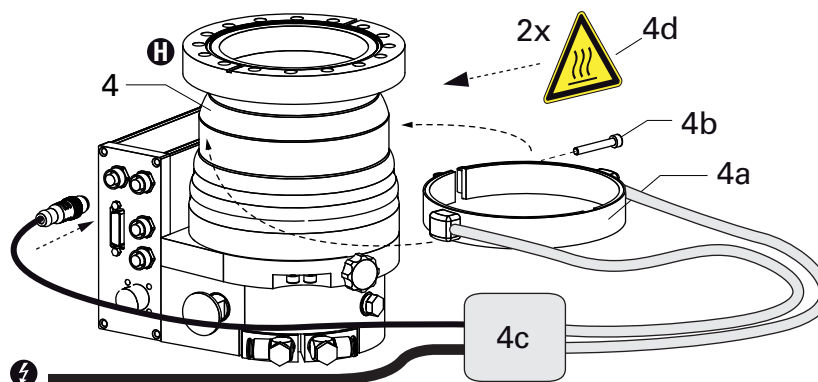

Fig. 9: Connecting the heating jacket

- | | | | | | |
|----|----------------|----|-------------------|----|-----------------|
| 4 | Pump casing | 4b | Fixing screw | 4d | Warning sticker |
| 4a | Heating jacket | 4c | Heating relay box | | |

- Bend open the outer heating jacket on the tensioning strap and place it sideways on to the cylindrical segment of the pump casing.
 - Do not bend the heating straps!
 - The heating jacket must seat completely on the casing segment.
- Fix the heating jacket with the fixing screw on the casing.
 - Observe the tightening torque for the fixing screw!

Fixing screw	Tightening torque in cold condition	Tightening torque during the heating-up	Singular retightening after the cooling down
M5	6 Nm	7 Nm	7 Nm
M6	11 Nm	12 Nm	12 Nm

Tightening torques for fixing screws of heating jackets

- Plug in and fix the accessory's control lead to the corresponding accessory connection port on the TC 400.

- ➔ Default for the casing heating is "accessory B2".
- ➔ Establish the mains supply for the relay box according to the accessory operating instructions.

Sealing gas connection

The turbopump must be operated with sealing gas to protect it, such as in the case of unclean processes or high gas throughput. The supply is made via a sealing gas valve or alternatively via a sealing gas throttle without control. The activation of the control valve for the sealing gas connection is not pre-installed in the electronic drive unit and has to be configured via their interfaces.

The permissible connection pressure is max. 1.5 bar absolute.

- When operating the pump with more than 50 % of the maximum gas throughput, sealing gas must be used to ensure rotor cooling.
- The sealing gas flow rate amounts 12-15 sccm for the HiPace 300 C.

Sealing gas supply without control valve

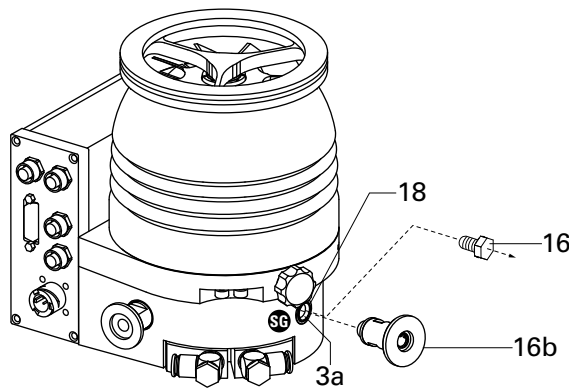

Fig. 10: Connecting the sealing gas throttle

18 Seal ring 16 Locking screw 16b Sealing gas throttle

- ➔ Unscrew the locking screw with seal ring out of the sealing gas connection.
- ➔ Screw the sealing gas throttle with sealing ring into the sealing gas connection.

Sealing gas supply with control valve

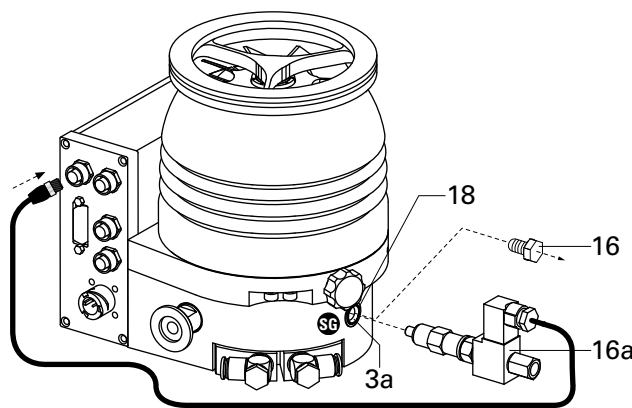

Fig. 11: Connecting the sealing gas valve

18 Seal ring 16 Locking screw 16a Sealing gas valve

- ➔ Unscrew the locking screw with seal ring out of the sealing gas connection.
- ➔ Screw the sealing gas valve with seal ring into the sealing gas connection.
- ➔ Insert the control cable of the accessory into a free accessory connector on the TC 400 and tighten.
- ➔ Make the settings and control via the interfaces of the electronic drive unit.

- Install the sealing gas supply (e.g. inert gas) via a connection adapter or on the inlet side (G 1/8") of the control valve.

Water cooling

The turbopumps HiPace 300 C with TC 400 have water cooling as standard equipment.

- In case of increased backing pressure (> 0.1 mbar) and/or operation with gas throughputs, either air or water cooling may be used.
- Generally use water cooling if the ambient temperature is > +35 °C.

Cooling water requirements

Cooling water connection	Swiveling screw-fitting with plug and socket connection
Hose lines	External diameter 8 mm Internal diameter 6 mm
Cooling water quality	filtrated, mechanically clean, optically clear, no turbidity, no sediments, chemically neutral
Oxygen content max.	4 mg/kg
Chloride content max.	100 mg/kg
Water hardness max.	10 °dH 12.53 °e 17.8 °fH 178 ppm CaCO ₃
Consumption of potassium permanganate max.	10 mg/kg
Carbon dioxide content max.	undetectable
Ammonia content max.	undetectable
pH-value	7 - 9
Fore-line overpressure max.	6 bar
Cooling water temperature	> dew point, max. 25 °C
Cooling water consumption at max. gas throughput	50 l/h

Connecting to a cooling water system

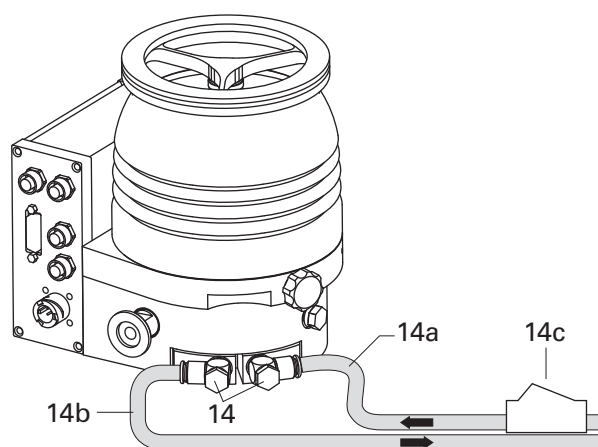

Fig. 12: Connecting the cooling water

14 Cooling water connection	14b Return line
14a Fore-line	14c Dirt trap

- Insert hoses for the water cooling fore- and return-line as far as they will go in one cooling water connection each.
- **Recommendation:** install dirt trap in the fore-line.
- Torque of the banjo fitting: 3-3.5 Nm.

6 Operation

6.1 Commissioning

The following important settings are programmed in the electronic drive unit ex factory.

- Parameter **[P:700]** Set value run-up time: 8 min
- Parameter **[P:027]** Gas mode: 0 = heavy gases
- Parameter **[P:701]** Rotation speed switchpoint: 80% of the nominal rotation speed
- Parameter **[P:720]** Venting rotation speed at delayed venting: 50% of the nominal rotation speed
- Parameter **[P:721]** Venting time: 3600 s
- Parameter **[P:708]** Set value power consumption 100 %

→ When water cooling is used: Open cooling water supply and check the flow.

→ When sealing gas is used: Open the sealing gas supply and check the flow.

→ Establish the mains for the power supply.



CAUTION	
Danger of the pump being destroyed	
Pumping of gases with a higher molecular mass in the wrong gas mode can lead to destruction of the pump.	
→ Ensure the gas mode is correctly set.	
→ Contact Pfeiffer Vacuum before using gases with a greater molecular mass (> 80).	

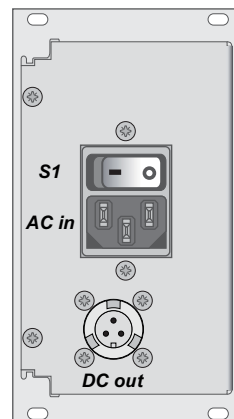
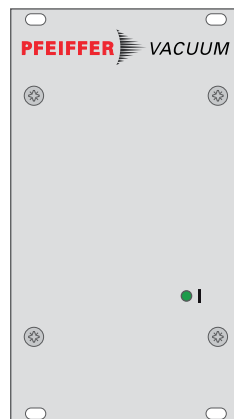

S1 Switch ON/OFF
 AC in Mains connection
 DC out Connection TC 400

Fig. 13: Front and rear view of a TPS mains pack

6.2 Operation modes

The following operation modes are available:

- Operation without operating unit
- Operation via "remote" connection
- Operation via RS485 and Pfeiffer Vacuum display and control units or PC
- Operation via field bus

6.3 Function description



WARNING

Danger due to open high vacuum flange

The rotor of the turbopump turns at high speed. If the high vacuum flange is open, there is a danger of cut injuries and that the pump can be destroyed by objects falling into it.

→ Never operate the pump with an open high vacuum flange.

Operation without operating unit



CAUTION

Automatic start

After bridging the contacts Pin 1, 3, 4, 14 on the connection "*remote*" or using the mating plug supplied **and** setting up the supply voltage, the turbopump will run up immediately.

→ Switch on the mains supply on the turbo pump immediately before operation.

→ For operation without the control unit, the 26-pole D-Sub plug must be in the "*remote*" connection on the TC 400.

→ Switch on the supply voltage with switch S1 on the power supply.

After operating voltage is applied, the TC 400 performs a self-test to check the supply voltage. Once the self test has been successfully completed on the TC 400, the turbopump and the backing pump - if connected - begin to operate.

Operation via "*remote*" connection

Remote control options are provided via the 26-pole D-Sub connector with the designation "*remote*" on the electronic drive unit.

→ Consider the following manuals for the operation via remote control:

- Operating instructions "Electronic drive unit TC 400"

Operation with DCU or HPU

→ Consider the following manuals for the operation via Pfeiffer Vacuum display and control units:

- Operating instructions "DCU"
- Operating instructions "HPU"
- Operating instructions "Electronic drive unit TC 400"

→ Switch on the supply voltage with switch S1 on the power supply or on the DCU 310.

→ Settings are possible via the RS485 by using DCU, HPU or PC.

Operation via field bus

Integrating and operating Pfeiffer Vacuum turbopumps in the customer's field bus system is possible for electronic drive units with a corresponding field bus panel.



→ Consider the following manuals for the operation via field bus:

- Operating instructions for the electronic drive unit with the respective connection panel

6.4 Monitoring of the operation conditions

Operating mode display via LED

LEDs in the front panel of the electronic drive unit show basic operating conditions of the turbopump. A differentiated malfunction and warning display is possible only for operation with DCU or HPU.

LED	Symbol	Steady OFF	Flashing (1/12 s active)	Blinking (1/2 s active)	Steady ON
Green		insufficient power supply	Pumping station "OFF" Rotation speed \leq 1Hz	Pumping station "OFF" Rotation speed $>$ 1 Hz	Pumping station "ON"
Yellow		no warning			Warning
Red		no malfunction			Malfunction

Temperature monitoring

The drive power is reduced in case of impermissible motor temperature or impermissibly high housing temperature. This can cause falling below the rotation speed switchpoint and so result in turning off the turbopump.

6.5 Switching off and venting

Switching off

After the turbopump is switched off, it must be vented to avoid contamination due to particles streaming back from the fore-vacuum area.

- Close the fore-vacuum line: Switch off the backing pump or close a fore-vacuum valve.
- Switch off the turbopump on the control unit or via remote control.
- Venting (possibilities, see below)
- For water cooling: Shut off the water supply.

Venting

Manually Venting

- Open the venting screw (included) in the venting connection of the turbopump about one turn.

Venting with Pfeiffer Vacuum Venting Valve

- Enable venting via the functions of the electronic drive unit.
- Settings are possible via the RS485 by using DCU, HPU or PC.

Venting rotation speed	Switch off the pumping station	Mains power failure ¹⁾
50% of the nominal rotation speed	Venting valve opens for 3600 s (1 h, works setting)	Venting valve opens for 3600 s (1 h, works setting)

¹⁾When mains power is restored the venting procedure is aborted.

Basic information for the rapid venting

Venting of the vacuum chamber in two steps. Ask for details on individual solutions from Pfeiffer Vacuum.

- Vent for 20 seconds at a rate of pressure rise of max. 15 mbar/s.
 - The valve cross section for the venting rate of 15 mbar/s must be adapted to the size of the vacuum chamber.
 - For small vacuum chambers, use the Pfeiffer Vacuum venting valve.
- Then vent with an additional venting valve of any desired size.

7 Maintenance / replacement



WARNING

Contamination of parts and operating fluid by pumped media is possible.

Poisoning hazard through contact with materials that damage health.

- In the case of contamination, carry out appropriate safety precautions in order to prevent danger to health through dangerous substances.
- Decontaminate affected parts before carrying out maintenance work.



NOTE

Disclaimer of liability

Pfeiffer Vacuum accepts no liability for personal injury or material damage, losses or operating malfunctions due to improperly performed maintenance. The liability and warranty entitlement expires.

7.1 Maintenance intervals and responsibilities

- Clean the turbopump externally with a lint-free cloth and little industrial alcohol.
- Replace the operating fluid reservoir and electronic drive unit yourself.
- Change the operating fluid reservoir at least every 2 years.
- Change the turbopump bearing at least every 2 years.
 - Contact Pfeiffer Vacuum Service.
- Clarify shorter maintenance intervals for extreme loads or impure processes with Pfeiffer Vacuum Service.
- For all other cleaning, maintenance or repair work, please contact your Pfeiffer Vacuum service location.

7.2 Replacing the operating fluid reservoir



WARNING

Poisoning hazard through contact with materials that damage health.

The operating fluid reservoir and parts of the pump may contain toxic substances from the pumped media.



- Dispose of operating fluid reservoir in accordance with the applicable regulations. Safety data sheet on request or under www.pfeiffer-vacuum.net
- Prevent health hazards or environmental damage due to contamination by means of appropriate safety precautions.
- Decontaminate affected parts before carrying out maintenance work.



NOTE

Lubricant filling

The lubricant reservoir is sufficiently filled with lubricant.

- Do not add additional lubricant.
- Turn off the vacuum pump, vent to atmospheric pressure and allow to cool, if necessary.
- Remove the vacuum pump from the system, if necessary.
- Close the flange openings by using the original protective covers.
- Turn the turbopump over onto the closed high vacuum flange.

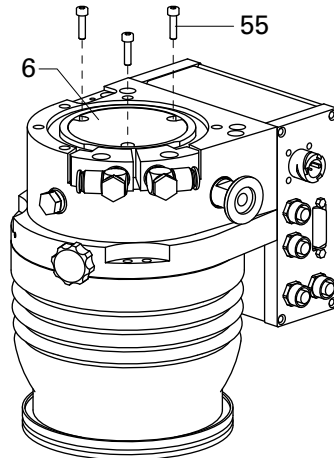

6 End cover
55 Allen head screw

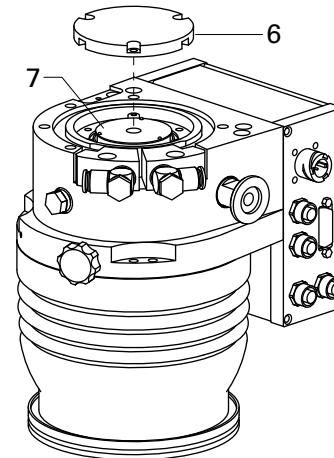

7 Operating fluid reservoir

- Screw out the allen head screws (3 pieces) from the end cover at the bottom of the turbopump.
- Remove the end cover. Pay attention to O-ring.

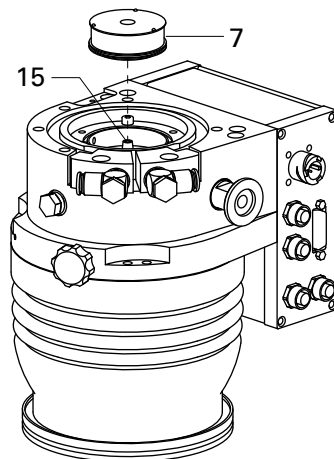

7 Operating fluid reservoir
15 Splash nut

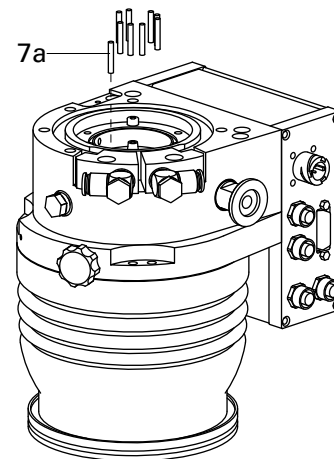

7a Porex rod

- Pull the operating fluid reservoir out of the bearing mounting.
- Using tweezers, pull out Porex rods (9 pieces).
- Remove impurities from the turbopump and the end cover with a clean, lint-free cloth. **Do not use any cleaning fluids!**
- Using tweezers, insert new Porex rods (9 pieces).
- Insert the new operating fluid reservoir with its felt side towards the splash nut into the bearing mounting.
- For the HiPace™ turbopumps the operating fluid reservoir can be pushed up against into the bearing cartridge.
- Screw in the end cover with the new O-ring.
 - Tightening torque **2.5 Nm**.

7.3 Replacing the electronic drive unit

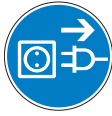

CAUTION

Damages to the pump and drive

Even after the mains power is switched off, the subsequently running pump delivers electric power to the electronic drive unit. There is a danger of electric body contact by premature separating the pump from the electronic drive unit.

- Never separate the electronic drive unit from the pump when the mains power is connected or the rotor is running.



NOTE

Operating parameters of the electronic drive unit

The factory operating parameters are always preset with replacement shipments.

- The use of a HPU enables the storing and the reuse of an existing parameter record.
- Reset any individually changed application parameters.
- Refer to the manual "Electronic drive unit".

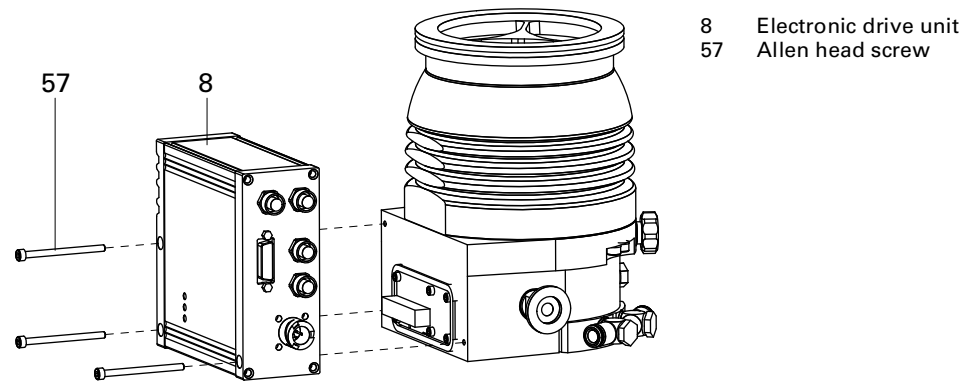

Fig. 14: Assembly / disassembly of the TC 400

- Do not exercise any mechanical load on the electronic drive unit.
- Turn off the vacuum pump, vent to atmospheric pressure and allow to cool, if necessary.
- Only separate the pump and the electronic drive unit from each other after disconnecting the supply voltage and the complete standstill of the pump.
- Remove the vacuum pump from the system, if necessary.
- Unscrew Allen head screws (3 pieces) from the electronic drive unit.
- Pull the electronic drive unit off the pump.
- Screw on and connect new electronic drive unit to the turbopump.
 - Tightening torque **2.5 Nm**.

Rotation speed set value

The typical nominal rotation speed of a turbopump is factory-set in the electronic drive unit. If the electronic drive unit is replaced or a different pump type is used, the reference set value of the nominal rotation speed must be confirmed. This procedure is part of a redundant safety system for avoiding excess rotation speeds.

HiPace	Nominal rotation speed confirmation [P:777]
300	1000 Hz
400 / 700 / 800	820 Hz

- Adjust the parameter [P:777] according to the pump type.
- **Alternatively:** If no display and control unit is available, please use the "Speed-Configurator" of the spare parts delivery.

8 Decommissioning

8.1 Shutting down for longer periods



WARNING

Contamination of parts and operating fluid by pumped media is possible.

Poisoning hazard through contact with materials that damage health.

- In the case of contamination, carry out appropriate safety precautions in order to prevent danger to health through dangerous substances.
- Decontaminate affected parts before carrying out maintenance work.

If the turbopump should be shut down for longer than a year:

- Remove the vacuum pump from the system, if necessary.
- Change the operating fluid reservoir.
- Close the high vacuum flange of the turbopump.
- Evacuate turbopump via the fore-vacuum flange.
- Vent turbopump via the venting connection with oil-free, dry air or inert gas.
- Close the flange openings by using the original protective covers.
- Close further connection ports by using the corresponding protective covers.
- Place pump upright on rubber feet.
- Store the pump only indoors at temperatures between -25 °C and +55 °C.
- In rooms with moist or aggressive atmospheres, the pump must be airproof shrink-wrapped in a plastic bag together with a bag of desiccant.

8.2 Re-starting



CAUTION

Re-starting

The serviceability of the operating fluid of the turbopump without operation is a maximum of 2 years. Before restarting after a shut-down of **2 years or longer**, carry out the following work:

- Replace the operating fluid reservoir
- Replace bearings
- Follow the maintenance instructions and inform Pfeiffer Vacuum
- Check turbopump for contamination and moisture.
- Clean the turbopump externally with a lint-free cloth and little industrial alcohol.
- If necessary, have Pfeiffer Vacuum Service clean the turbopump completely.
- If necessary, have the bearings replaced. Take into account the total running time.
- Change the operating fluid reservoir.
- Installation and commissioning in accordance with the operating instructions.

8.3 Disposal

Products or parts thereof (mechanical and electrical components, operating fluids, etc.) may cause environmental burden.

- Safely dispose of the materials according to the locally applicable regulations.

9 Malfunctions

If malfunctions on the pump occur, you will find possible causes and instructions for repair in the following table.

9.1 Rectifying malfunctions

Problem	Possible causes	Remedy
Pump will not start; none of the built-in LEDs on the TC 400 lights up	• Electrical supply interrupted	⇒ Check plug contacts on the power supply ⇒ Check supply lines on the power supply ⇒ Check the output voltage (24 / 48 VDC) on the connection "DC out" of the power supply ⇒ Check the plug contacts on the TC
	• Operating voltage incorrect	⇒ Apply correct operating voltage ⇒ Observe the rating plate
	• No operating voltage applied	⇒ Apply operating voltage
	• TC 400 defective	⇒ Exchange the TC 400 ⇒ Contact the Pfeiffer Vacuum Service
Pump will not start; green LED on the TC 400 is flashing	• At operation without control panel: Pins 1-3, 1-4 or 1-14 are not connected on the "remote" connection	⇒ Connect the pins 1-3, 1-4 or 1-14 on the "remote" connection ⇒ Install the mating plug (scope of delivery) to the "remote" connection.
	• At operation via RS485: Bridge at Pin 1-14 prevents control commands	⇒ Remove the bridge between pins 1 and 14 from the "remote" connection ⇒ Remove the mating plug from the "remote" connection.
	• Voltage drop in the cable too high	⇒ Use a suitable cable
Pump does not attain the final rotational speed within the specified run-up time	• Fore-vacuum pressure too high	⇒ Ensure function and suitability of the backing pump
	• Leak	⇒ Perform leak detection ⇒ Check sealings and flange fastenings ⇒ Eliminate leaks
	• Gas throughput too high	⇒ Reduce process gas supply
	• Rotor runs hard, bearing defective	⇒ Check the bearing for noises ⇒ Contact the Pfeiffer Vacuum Service
	• Setpoint for run-up time too low	⇒ Extend the run-up time via DCU, HPU or PC
	• Thermal overload: – Lack of air ventilation – Water flow too low – Fore-vacuum pressure too high – Ambient temperature too high	⇒ Reduce thermal loads – Ensure adequate cooling – Ensure the cooling water flow – Lower the fore-vacuum pressure – Adjust ambient conditions
Pump does not attain the ultimate pressure	• Pump is dirty	⇒ Bake out the pump ⇒ Cleaning in case of heavy contamination – Contact the Pfeiffer Vacuum Service
	• Vacuum chamber, pipes or pump are leaky	⇒ Leak detection starting from the vacuum chamber ⇒ Eliminate leaks
Unusual noises during operation	• Bearing damage	⇒ Contact the Pfeiffer Vacuum Service
	• Rotor damage	⇒ Contact the Pfeiffer Vacuum Service
	• Splinter shield or protective screen are loose	⇒ Correct the seat of the splinter shield or the protective screen ⇒ Observe the installation notes
Red LED on the TC 400 is on	• Collective fault	⇒ Reset by switching the mains OFF/ON ⇒ Reset via pin 13 on the "REMOTE" connection ⇒ Differentiated malfunction display is possible via DCU or HPU ¹⁾ ⇒ Contact the Pfeiffer Vacuum Service

¹⁾ If no Pfeiffer Vacuum display and control unit is available, please contact the Pfeiffer Vacuum Service.

10 Service

Pfeiffer Vacuum offers first-class service!

- Operating fluid and bearing change on the spot by Pfeiffer Vacuum FieldService
- Maintenance / repair in the nearby ServiceCenter or ServicePoint
- Fast replacement with exchange products in mint condition
- Advice on the most cost-efficient and quickest solution

Detailed information, addresses and forms at: www.pfeiffer-vacuum.net (**Service**).

Maintenance and repair in the Pfeiffer Vacuum ServiceCenter

The following steps are necessary to ensure a fast, smooth servicing process:

- Download the forms "Service Request" and "Declaration on Contamination".¹⁾
- Fill out the "Service Request" form and send it by fax or e-mail to your
- Pfeiffer Vacuum service address.
- Include the confirmation on the service request from Pfeiffer Vacuum with your shipment.
- Fill out the declaration on contamination and include it in the shipment (required!).
- Dismantle all accessories.
- Drain the operating fluid (applies for turbopumps with pumping speed > 800 l/s).
- Leave electronic drive on the pump.
- Close the flange openings by using the original protective covers.
- If possible, send pump or unit in the original packaging.

Sending of contaminated pumps or devices

No units will be accepted if they are contaminated with micro-biological, explosive or radioactive substances. "Hazardous substances" are substances and compounds in accordance with the hazardous goods directive (current version). If pumps are contaminated or the declaration on contamination is missing, Pfeiffer Vacuum performs decontamination at the shipper's expense.

- Neutralise the pump by flushing it with nitrogen or dry air.
- Close all openings airtight.
- Seal the pump or unit in suitable protective film.
- Return the pump/unit only in a suitable and sturdy transport container and send it in while following applicable transport conditions.

Exchange unit

The factory operating parameters are always preset with exchange units. If you use changed parameters for your application, you have to set these again.

Service orders

All service orders are carried out exclusively according to our repair conditions for vacuum units and components.

¹⁾ Forms under www.pfeiffer-vacuum.net

11 Spare parts HiPace 300 C

Item	Designation	Size	Order number	Notes	Pieces	Order qty.
7	Operating fluid reservoir		PM 143 597 -T	incl. Porex rods	1	
8	Electronic drive unit TC 400		according to the rating plate	depends on the connection panel	1	
14	Swiveling screw-fitting		P 4131 007 D	water cooling	2	
93	Mating plug "remote"		PM 061 378 -X	with bridges	1	

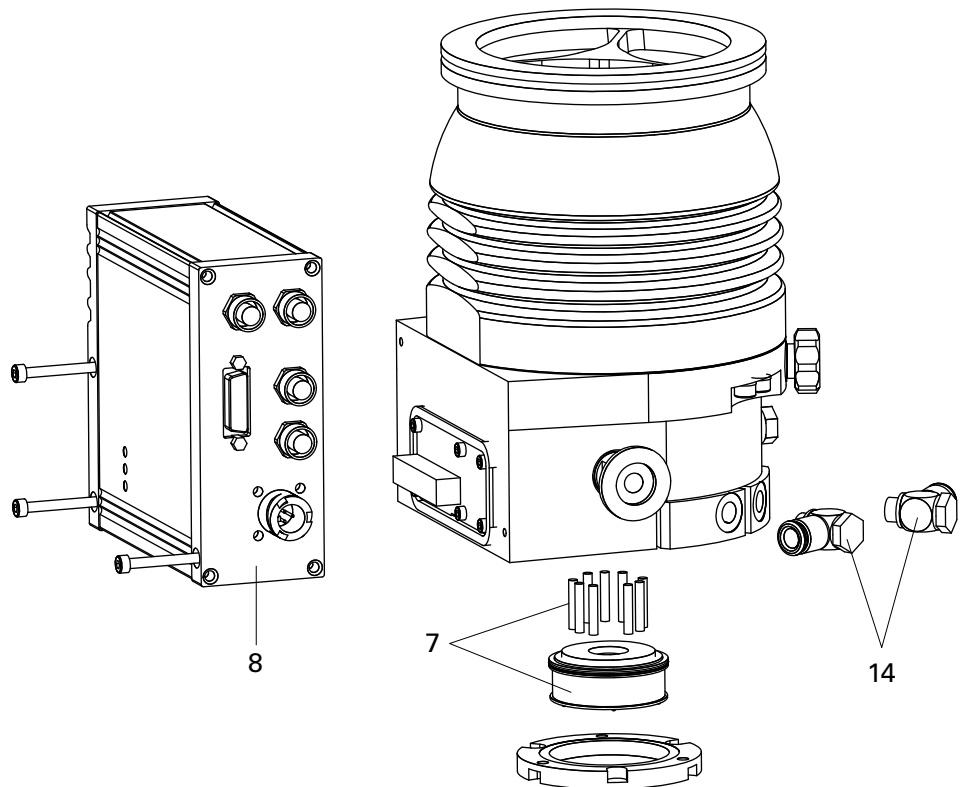

Please also specify model number of the the rating plate when ordering accessories or spare parts.

12 Accessories

12.1 HiPace 300 C, 24 V DC

Designation	HiPace™ 300 C with TC 400, DN 100 ISO-K	HiPace™ 300 C with TC 400, DN 100 CF-F	HiPace™ 300 C with TC 400, DN 100 ISO-F
DCU 310, Display control unit incl. power supply	PM C01 822	PM C01 822	PM C01 822
TPS 310, mains pack for wall / standard rail fitting	PM 061 342-T	PM 061 342-T	PM 061 342-T
TPS 311, mains pack 19" rack module 3 RU	PM 061 346-T	PM 061 346-T	PM 061 346-T
DCU 002, Display control unit	PM 061 348-T	PM 061 348-T	PM 061 348-T
HPU 001, handheld programming unit	PM 051 510-T	PM 051 510-T	PM 051 510-T
Accessories package for HPU - Power supply, software and PC cable	PM 061 005-T	PM 061 005-T	PM 061 005-T
230 V AC mains cable with Euro-style safety plug, IEC power socket (straight), 3 m	P 4564 309 ZA	P 4564 309 ZA	P 4564 309 ZA
115 V AC mains cable with UL plug, IEC power socket (straight), 3 m	P 4564 309 ZE	P 4564 309 ZE	P 4564 309 ZE
208 V AC mains cable with UL plug, 3 m	P 4564 309 ZF	P 4564 309 ZF	P 4564 309 ZF
Connection cable for linking HiPace with TC 400 to power supply TPS/DCU 310 / 311 / 400 / 401	PM 061 352-T	PM 061 352-T	PM 061 352-T
24 V DC venting valve, G 1/8", for connection to TC 400 / 1200	PM Z01 291	PM Z01 291	PM Z01 291
TTV 001, air drier for venting turbopumps	PM Z00 121	PM Z00 121	PM Z00 121
Air cooling for HiPace 300 with TC 400, plug M12	PM Z01 302	PM Z01 302	PM Z01 302
Heating jacket for HiPace 300 with TC 400/TCP 350, 230 V AC, Euro-style safety plug		PM 061 366-T	
Heating jacket for HiPace 300 with TC 400/TCP 350, 208 V AC, UL plug		PM 061 367-T	
Heating jacket for HiPace 300 with TC 400/TCP 350, 115 V AC, UL plug		PM 061 368-T	
Backing pump relay box, single phase 5 A, for TC 400/1200	PM 061 374-T	PM 061 374-T	PM 061 374-T
Backing pump relay box, single phase 20 A, for TC 400/1200, TCP 350 and TM 3000	PM 061 375-T	PM 061 375-T	PM 061 375-T
TVV 001 fore-vacuum safety valve, 230 V AC	PM Z01 205	PM Z01 205	PM Z01 205
TVV 001 fore-vacuum safety valve, 115 V AC	PM Z01 206	PM Z01 206	PM Z01 206
Sealing gas valve for HiPace 300, 400 and 700 with TC 400	PM Z01 312	PM Z01 312	PM Z01 312
Sealing gas throttle for HiPace 300, 400 and 700	PM Z01 317	PM Z01 317	PM Z01 317
Centering ring, with multifunction coating, DN 100 ISO-K/-F pumps	PM 016 210-U		PM 016 210-U
Centering ring, with multifunction coating and integrated protection screen, DN 100 ISO-K/-F	PM 016 212-U		PM 016 212-U
Centering ring, with multifunction coating and integrated splinter shield, DN 100 ISO-K/-F	PM 016 211-AU		PM 016 211-AU
Protection screen for Turbopumps, DN 100 CF-F		PM 016 336	
Splinter shield for Turbopumps, DN 100 CF-F flange		PM 016 315	
Vibration damper for HiPace 300 and HiPace 400, DN 100 ISO-K	PM 006 459-X		
Vibration damper for HiPace 300 and HiPace 400, DN 100 CF-F		PM 006 488-X	
USB converter to RS-485 interface	PM 061 207-T	PM 061 207-T	PM 061 207-T
Interface cable, 3 m, M12	PM 061 283-T	PM 061 283-T	PM 061 283-T
Y-Connector M12 to RS-485	P 4723 010	P 4723 010	P 4723 010
Y-Connector M12 for accessories	P 4723 012	P 4723 012	P 4723 012
Mounting kit for HiPace 300, DN 100 ISO-K, including coated centering ring, bracket screws	PM 016 365-T		
Mounting kit for HiPace 300, DN 100 ISO-K, including coated centering ring, protection screen, clamping screws	PM 016 367-T		
Mounting kit for HiPace 300, DN 100 ISO-K, including coated centering ring, splinter shield, bracket screws	PM 016 366-T		
Set of hexagon bolts, 16 count, M8, DN 100 CF		PM 016 690-T	
Set of stud screws, 16 count, M8, DN 100 CF		PM 016 692-T	

Designation	HiPace™ 300 C with TC 400, DN 100 ISO-K	HiPace™ 300 C with TC 400, DN 100 CF-F	HiPace™ 300 C with TC 400, DN 100 ISO-F
Mounting kit for HiPace 300 and HiPace 400, DN 100 ISO-F, including coated centering ring, hexagon screws			PM 016 450-T
Mounting kit for HiPace 300 und HiPace 400, DN 100 ISO-F, including coated centering ring, protection screen, hexagon screws			PM 016 452-T
Mounting kit for HiPace 300 and HiPace 400, DN 100 ISO-F, including coated centering ring, splinter shield, hexagon screws			PM 016 451-T
Mounting kit for HiPace 300 and HiPace 400, DN 100 ISO-F, including coated centering ring, stud screws			PM 016 455-T
Mounting kit for HiPace 300 and HiPace 400, DN 100 ISO-F, including coated centering ring, protection screen, stud screws			PM 016 457-T
Mounting kit for HiPace 300 and HiPace 400, DN 100 ISO-F, including coated centering ring, splinter shield, stud screws			PM 016 456-T

12.2 Differences at HiPace 300 C, 48 V DC

Designation	HiPace™ 300 C with TC 400, DN 100 ISO-K	HiPace™ 300 C with TC 400, DN 100 CF-F	HiPace™ 300 C with TC 400, DN 100 ISO-F
DCU 400, Display control unit incl. power supply	PM C01 823	PM C01 823	PM C01 823
TPS 400, mains pack for wall/standard rail fitting	PM 061 343-T	PM 061 343-T	PM 061 343-T
TPS 401, mains pack 19" rack module 3 RU	PM 061 347-T	PM 061 347-T	PM 061 347-T

13 Technical data and dimensions

13.1 General

Basic principles for the Technical Data of Pfeiffer Vacuum Turbopumps:

- Recommendations of PNEUROP committee PN5
- ISO 21360; 2007: "Vacuum technology - Standard methods for measuring vacuum-pump performance - General description"
- ISO 5302; 2003: "Vacuum technology - Turbomolecular pumps - Measurement of performance characteristics"
- Ultimate pressure: using a test dome and a 48 hrs. period of baking out
- Gas throughput: water cooling; backing pump = rotary vane pump (20 m³/h)
- Cooling water consumption: at max. gas throughput, cooling water temp. 25 °C
- Integral leak rate: using a Helium concentration of 100 %, period 10 s
- Acoustic pressure: Distance 1 m to the pump

13.2 HiPace 300 C, 24 V DC

Parameter	HiPace™ 300 C	HiPace™ 300 C	HiPace™ 300 C
Flange (in)	DN 100 ISO-K	DN 100 CF-F	DN 100 ISO-F
Flange (out)	DN 16 ISO-KF	DN 16 ISO-KF	DN 16 ISO-KF
Pumping speed for Ar	250 l/s	250 l/s	250 l/s
Pumping speed for CF ₄	195 l/s	195 l/s	195 l/s
Pumping speed for H ₂	125 l/s	125 l/s	125 l/s
Pumping speed for He	220 l/s	220 l/s	220 l/s
Pumping speed for N ₂	245 l/s	245 l/s	245 l/s
Compression ratio for Ar	$> 1 \cdot 10^7$	$> 1 \cdot 10^7$	$> 1 \cdot 10^7$
Compression ratio for CF ₄	$> 1 \cdot 10^7$	$> 1 \cdot 10^7$	$> 1 \cdot 10^7$
Compression ratio for H ₂	$3 \cdot 10^2$	$3 \cdot 10^2$	$3 \cdot 10^2$
Compression ratio for He	$2.2 \cdot 10^3$	$2.2 \cdot 10^3$	$2.2 \cdot 10^3$
Compression ratio for N ₂	$> 1 \cdot 10^6$	$> 1 \cdot 10^6$	$> 1 \cdot 10^6$
Gas throughput at full rotational speed for Ar	4.4 mbar l/s	4.4 mbar l/s	4.4 mbar l/s
Gas throughput at full rotational speed for CF ₄	5.4 mbar l/s	5.4 mbar l/s	5.4 mbar l/s
Gas throughput at full rotational speed for He	> 20 mbar l/s	> 20 mbar l/s	> 20 mbar l/s
Gas throughput at full rotational speed for H ₂	> 50 mbar l/s	> 50 mbar l/s	> 50 mbar l/s
Gas throughput at full rotational speed for N ₂	17 mbar l/s	17 mbar l/s	17 mbar l/s
Fore Vacuum max. for Ar	1.8 mbar	1.8 mbar	1.8 mbar
Fore Vacuum max. for CF ₄	2.6 mbar	2.6 mbar	2.6 mbar
Fore Vacuum max. for H ₂	0.09 mbar	0.09 mbar	0.09 mbar
Fore Vacuum max. for He	0.45 mbar	0.45 mbar	0.45 mbar
Fore Vacuum max. for N ₂	1 mbar	1 mbar	1 mbar
Run-up time	1.2 min	1.2 min	1.2 min
Ultimate pressure with OnTool™ DryPump	$< 1 \cdot 10^{-7}$ mbar	$< 1 \cdot 10^{-8}$ mbar	$< 1 \cdot 10^{-7}$ mbar
Rotation speed ± 2 %	60000 rpm	60000 rpm	60000 rpm
Rotation speed: variable	20-100 %	20-100 %	20-100 %
Power characteristic line in gas mode 1, vertex A	201/60000 W/rpm	201/60000 W/rpm	201/60000 W/rpm
Power characteristic line in gas mode 1, vertex B	221/49980 W/rpm	221/49980 W/rpm	221/49980 W/rpm
Power characteristic line in gas mode 0, vertex C	137/60000 W/rpm	137/60000 W/rpm	137/60000 W/rpm
Power characteristic line in gas mode 0, vertex D	180/49980 W/rpm	180/49980 W/rpm	180/49980 W/rpm
Power characteristic line in gas mode 2, vertex E	201/60000 W/rpm	201/60000 W/rpm	201/60000 W/rpm
Power characteristic line in gas mode 2, vertex F	221/49980 W/rpm	221/49980 W/rpm	221/49980 W/rpm
Sound pressure level	≤ 50 dB (A)	≤ 50 dB (A)	≤ 50 dB (A)
Relative humidity of air	5-85, non- condensing %	5-85, non- condensing %	5-85, non- condensing %
Protection category	IP 54	IP 54	IP 54
Connection pressure max. for venting/sealing gas valve	1.5 bar	1.5 bar	1.5 bar
Operating voltage	24 ± 5 % V DC	24 ± 5 % V DC	24 ± 5 % V DC
Operating voltage power supply	90-265 V AC	90-265 V AC	90-265 V AC

Parameter	HiPace™ 300 C	HiPace™ 300 C	HiPace™ 300 C
Integral leak rate	$< 1 \cdot 10^{-7}$ mbar l/s	$< 1 \cdot 10^{-7}$ mbar l/s	$< 1 \cdot 10^{-7}$ mbar l/s
Power consumption max.	300 W	300 W	300 W
Current consumption max.	12.5 A	12.5 A	12.5 A
Venting connection	G 1/8"	G 1/8"	G 1/8"
Weight	6.4 kg	8.4 kg	6.7 kg
Cooling method, standard	Water	Water	Water
Cooling method, optional	Air	Air	Air
Cooling water temperature	15-35 °C	15-35 °C	15-35 °C
Cooling water consumption	50 l/h	50 l/h	50 l/h
Permissible magnetic field max.	5.5 mT	5.5 mT	5.5 mT
Interfaces	RS-485, Remote	RS-485, Remote	RS-485, Remote

13.3 Differences at HiPace 300 C, 48 V DC

Parameter	HiPace™ 300 C	HiPace™ 300 C	HiPace™ 300 C
Flange (in)	DN 100 ISO-K	DN 100 CF-F	DN 100 ISO-F
Run-up time	0.7 min	0.7 min	0.7 min
Operating voltage	$48 \pm 5 \%$ V DC	$48 \pm 5 \%$ V DC	$48 \pm 5 \%$ V DC
Power consumption max.	400 W	400 W	400 W
Current consumption max.	8.4 A	8.4 A	8.4 A

13.4 Dimensions

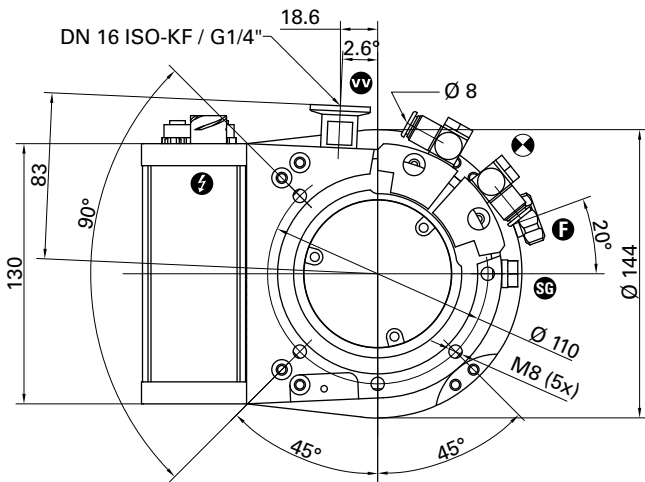

Fig. 15: HiPace 300 C, DN 100 ISO-K

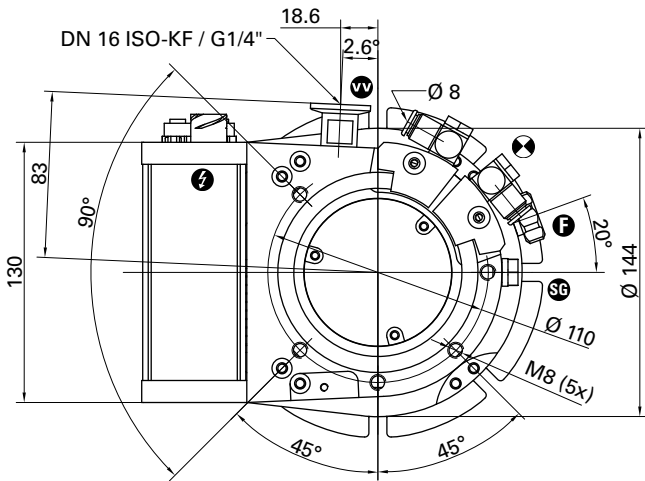
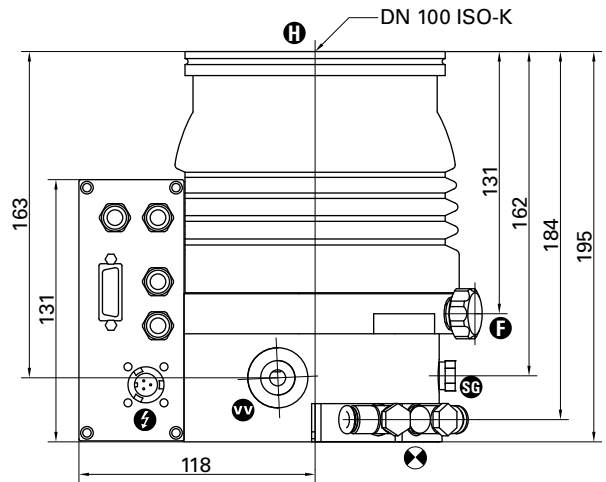

Fig. 16: HiPace 300 C, DN 100 ISO-F

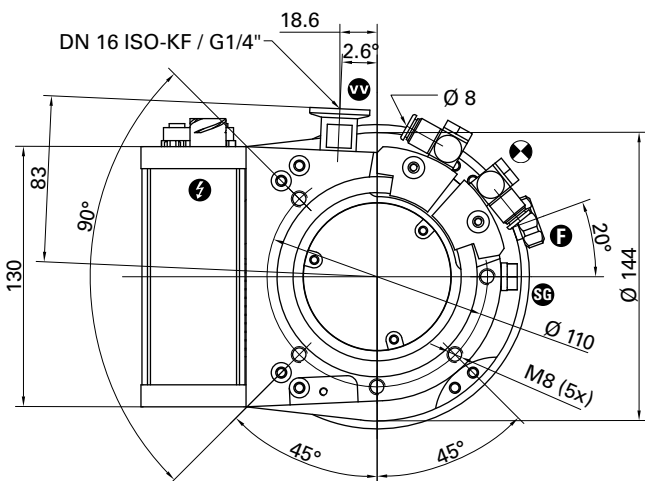
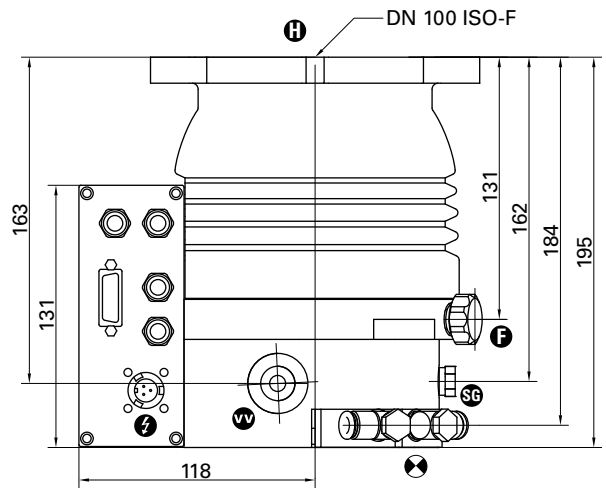
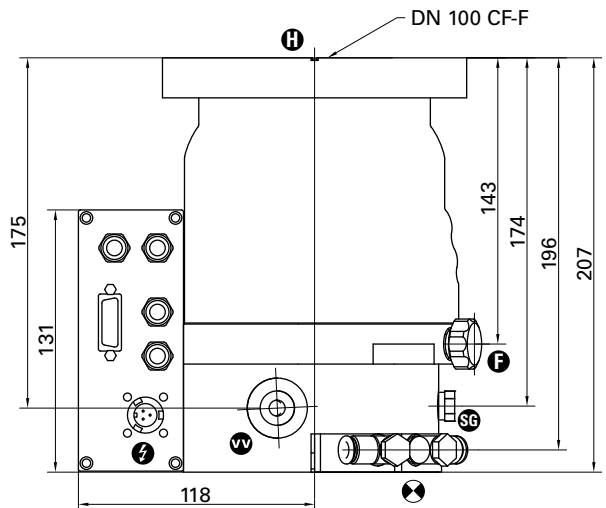

Fig. 17: HiPace 300 C, DN 100 CF-F





Declaration of conformity

according to the EC directive:

- **Machinery 2006/42/EC (Annex II, no. 1 A)**

We hereby declare that the product cited below satisfies all relevant provisions of EC directive "Machinery" **2006/42/EC**.

In addition, the product cited below satisfies all relevant provisions of EC directive "Electromagnetic Compatibility" **2004/108/EC**.

The agent responsible for compiling the technical documentation is Mr. Jörg Stanzel, Pfeiffer Vacuum GmbH, Berliner Straße 43, 35614 Asslar.

HiPace 300 C

Guidelines, harmonised standards and national standards and specifications which have been applied:

DIN EN ISO 12100-1 : 2004

DIN EN ISO 12100-2 : 2004

DIN EN ISO 14121-1 : 2007

DIN EN 1012-2 : 1996

DIN EN 61010-1 : 2002

Signatures:

Pfeiffer Vacuum GmbH
Berliner Straße 43
35614 Asslar
Germany

(M. Bender)
Managing Director

(Dr. M. Wiemer)
Managing Director

CE/2010

**Leading. Dependable.
Customer Friendly**

Pfeiffer Vacuum stands for innovative and custom vacuum solutions worldwide. For German engineering art, competent advice and reliable services.

Ever since the invention of the turbopump, we've been setting standards in our industry. And this claim to leadership will continue to drive us in the future.

**You are looking for a
perfect vacuum solution?
Please contact us:**

Germany

Pfeiffer Vacuum GmbH
Headquarters
Tel.: +49 (0) 6441 802-0
info@pfeiffer-vacuum.de

Benelux

Pfeiffer Vacuum GmbH
Sales & Service Benelux
Tel.: +800-pfeiffer
benelux@pfeiffer-vacuum.de

China

Pfeiffer Vacuum
(Shanghai) Co., Ltd.
Tel.: +86 21 3393 3940
info@pfeiffer-vacuum.cn

France

Pfeiffer Vacuum France SAS
Tel.: +33 169 30 92 82
info@pfeiffer-vacuum.fr

Great Britain

Pfeiffer Vacuum Ltd.
Tel.: +44 1908 500600
sales@pfeiffer-vacuum.co.uk

India

Pfeiffer Vacuum India Ltd.
Tel.: +91 40 2775 0014
pfeiffer@vsnl.net

Italy

Pfeiffer Vacuum Italia S.p.A.
Tel.: +39 02 93 99 05 1
contact@pfeiffer-vacuum.it

Korea

Pfeiffer Vacuum Korea Ltd.
Tel.: +82 31 266 0741
sales@pfeiffer-vacuum.co.kr

Austria

Pfeiffer Vacuum Austria GmbH
Tel.: +43 1 894 17 04
office@pfeiffer-vacuum.at

Sweden

Pfeiffer Vacuum Scandinavia AB
Tel.: +46 8 590 748 10
sales@pfeiffer-vacuum.se

Switzerland

Pfeiffer Vacuum (Schweiz) AG
Tel.: +41 44 444 22 55
info@pfeiffer-vacuum.ch

United States

Pfeiffer Vacuum Inc.
Tel.: +1 603 578 6500
contact@pfeiffer-vacuum.com