

KINNEY® KMBD™ SERIES

Mechanical Vacuum Boosters

Models 200 240 400 540 720 850 1600 2000 2700

INSTALLATION OPERATION MAINTENANCE REPAIR MANUAL

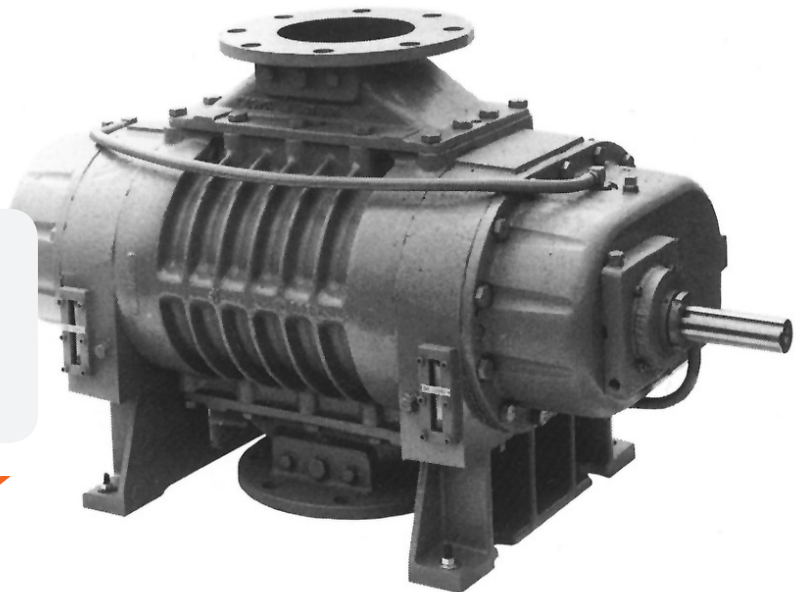

FOR SALES AND SERVICE PLEASE CALL:

PTB SALES T :: 866.332.0500
F :: 626.334.2151
www.ptbsales.com

DATE SERVICED: _____

VIEW OUR INVENTORY

WARNING

DO NOT OPERATE
BEFORE READING MANUAL



Tuthill Vacuum & Blower Systems
4840 West Kearney Street
Springfield, Missouri USA 65803-8702
o 417.865.8715 800.825.6937 f 417.865.2950
www.tuthillvacuumblower.com

SAFETY INSTRUCTIONS

1. Do not operate before reading the enclosed instruction manual.
2. Use adequate protection, warning and safety equipment necessary to protect against hazards involved in installation and operation of this equipment.

NOTICE

1. The safety instruction tags shown below were attached to your unit prior to shipment. Do not remove, paint over or obscure in any manner.
2. Failure to heed these warnings could result in serious bodily injury to the personnel operating and maintaining this equipment.



SAFETY WARNINGS

- Keep hands and clothing away from rotating machinery, inlet and discharge openings.
- Booster and drive mounting bolts must be secured.
- Drive belts and coupling guards must be in place.
- Noise level may require ear protection.
- Booster heat can cause burns if touched.

TUTHILL VACUUM AND BLOWER SYSTEMS — SPRINGFIELD, MO USA

IMPORTANT

In order to assure you of the full benefits of our product warranty, please complete, tear out and return the warranty registration card located on the back cover of this manual, or you can register your product online at:

<http://www.tuthillvacuumblower.com/index.cfm/contact-us/product-registration/>

SAFETY PRECAUTIONS

For equipment covered specifically or indirectly in this instruction book, it is important that all personnel observe safety precautions to minimize the chances of injury. Among many considerations, the following should particularly be noted:

- Booster casing and associated piping or accessories may become hot enough to cause major skin burns on contact.
- Internal and external rotating parts of the booster and driving equipment can produce serious physical injuries. Do not reach into any opening in the booster while it is operating, or while subject to accidental starting. Cover external moving parts with adequate guards.
- Disconnect power before doing any work, and avoid bypassing or rendering inoperative any safety or protective devices.
- If booster is operated with piping disconnected, place a strong, coarse screen over the inlet and avoid standing in discharge air stream.
- Avoid extended exposure in close proximity to machinery with high intensity noise levels.
- Use proper care and good procedures in handling, lifting, installing, operating, and maintaining the equipment.
- Other potential hazards to safety may also be associated with operation of this equipment. All personnel working in or passing through the area should be warned by signs and trained to exercise adequate general safety precautions.
- Hearing protection may be required depending on silencing capabilities.

TABLE OF CONTENTS

SECTION	PAGE
SAFETY PRECAUTIONS	2
INTRODUCTION	4
DESCRIPTION	4
INSTALLATION	4
GENERAL	4
SAFETY	4
LUBRICATION	5
PIPING CONNECTIONS	5
COOLING WATER SPECIFICATIONS	6
MOTOR DRIVES	6
DIRECT COUPLED	6
V-BELTS	6
ELECTRICAL CONNECTIONS	7
OPERATION	7
STARTING	7
OPERATING	7
STOPPING	7
MAINTENANCE	8
GENERAL	8
SPARE PARTS	8
REPAIR SERVICE	8
DISASSEMBLY AND ASSEMBLY INSTRUCTIONS	8-12
DISASSEMBLY — KMBD-200, 400	8
ASSEMBLY — KMBD-200, 400	9
GENERAL	9
DISASSEMBLY — KMBD-540, 720, 850, 1600, 2000, 2700	11
ASSEMBLY — KMBD-540, 720, 850, 1600, 2000, 2700	12
GENERAL	12
FREQUENTLY ASKED QUESTIONS	15
CLEARANCES	16
TORQUE CHART	16
BYPASS MODELS - KMBD-400BP & KMBD-720 BP	17
DRAWINGS AND PARTS LISTS	18-26
KMBD-200 AND KMBD-300 PARTS LIST	18
KMBD-540 AND KMBD-720 PARTS LIST	19
KMBD-850, 1600, 2000, AND 2700 PARTS LIST	20
ASSEMBLY PRINTS FOR KMBD-200 AND 400 CUTAWAY VIEW	21
ASSEMBLY PRINTS FOR KMBD-200 AND 400 SIDE AND END VIEWS	22
ASSEMBLY PRINTS FOR KMBD-540 AND KMBD-570 CUTAWAY VIEW	23
ASSEMBLY PRINTS FOR KMBD-540 AND KMBD-570 SIDE AND END VIEWS	24
ASSEMBLY PRINTS FOR KMBD-850, 1600, 2000, AND 2700 CUTAWAY VIEW	25
ASSEMBLY PRINTS FOR KMBD-850, 1600, 2000, AND 2700 SIDE AND END VIEWS	26
WARRANTY – VACUUM PRODUCTS	30

INTRODUCTION

CONGRATULATIONS on your purchase of a new Mechanical Vacuum Booster from Tuthill Vacuum & Blower Systems. Please examine the booster for shipping damage, and if any damage is found, report it immediately to the carrier. If the booster is to be installed at a later date make sure it is stored in a clean, dry location and rotated regularly. Make sure covers are kept on all openings. If booster is stored outdoors be sure to protect it from weather and corrosion.

Mechanical Vacuum Boosters are built to exacting standards and if properly installed and maintained will provide many years of reliable service. We urge you to take time to read and follow every step of these instructions when installing and maintaining your blower. We have tried to make these instructions as straightforward as possible. We realize getting any new piece of equipment up and running in as little time as possible is imperative to production.

WARNING: Serious injury can result from operating or repairing this machine without first reading the service manual and taking adequate safety precautions.

IMPORTANT: Record the booster model and serial numbers of your machine in the OPERATING DATA form on the inside back cover of this manual. You will save time and expense by including this reference identification on any replacement part orders, or if you require service or application assistance.

This manual covers the installation, operation, and maintenance of the Tuthill Vacuum & Blower Systems Mechanical Vacuum Boosters listed in Table 1.

DESCRIPTION

The Mechanical Vacuum Boosters manufactured by Tuthill Vacuum & Blower Systems are lobe type, positive displacement units, designed with extra heavy shafts and bearings to permit high power input. They incorporate a unique rotor profile in which all gas joints or mating surfaces are sealed vacuum tight. Unit construction consists of two figure-eight shaped rotors enclosed in a precision machined housing supported at each end by precision bearings. The power drive turns the drive rotor directly and rotates the driven rotor by means of specially forged, heat treated, crowned and ground precision helical gears. Efficient and effective vacuum pumping is accomplished by trapping a volume of gas at the booster inlet and between each rotor and the booster housing. This volume of gas is quickly and cleanly evacuated by the fast revolving rotors which carry the air to the exhaust side of the booster where the air is then discharged to the backing pump.

INSTALLATION

GENERAL

Carefully check to ensure that no transit damage has been sustained. If damage has occurred from shipment a claim must be filed with the carrier immediately; preserve the shipping container for inspection by the carrier. Do not return the booster to the factory without first obtaining shipping instructions from us.

Remove protective covers and plugs only as connections are made. Mount the booster on a flat, level surface of sufficient rigidity. Shim under the legs where necessary so as to have each leg of the booster support a proportional share of the booster weight. This is necessary to prevent eventual twisting of the booster.

SAFETY

Booster housing and associated piping or accessories may become hot enough to cause major skin burns on contact. Internal and external rotating parts of the booster and driving equipment can produce serious physical injuries. The booster should never be run with the inlet or discharge piping removed. If it becomes necessary to inspect the rotating parts of the booster or to change V-belts, be absolutely sure that all power to the motor controls has been shut off, the motor controls are locked out, and properly tagged before proceeding.

Avoid extended exposure in close proximity to machinery with high intensity noise levels. Wear adequate ear protection. Use proper care and good procedures in handling, lifting, installing, operating, and maintaining the equipment.

LUBRICATION

TABLE 1

KMBD MODELS 200, 400, 540, 720, 850, 1600, 2000 & 3000	(1) MECHANICAL SEAL	(2) SLINGER SEAL
(1) Interconnecting cooling water between drive shaft bearing housing and the two oil reservoirs. Mechanical seals are used throughout.		
(2) Water cooled only at drive shaft bearing housing. Rotor seals are slinger type and a mechanical seal on the drive shaft.		

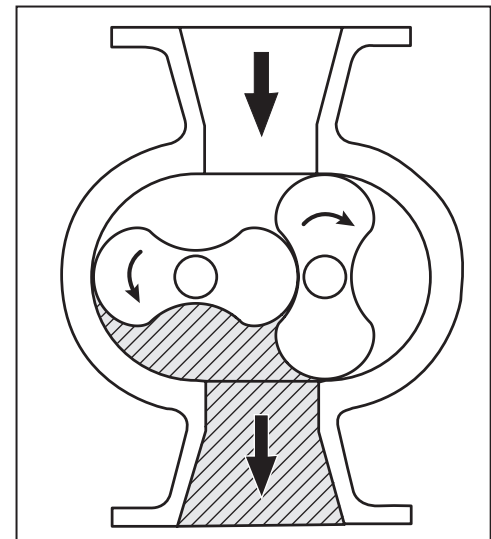

Figure 1 - Illustration of flow direction in a vacuum booster

TABLE 2 — SPECIFICATIONS

KMBD MODEL	APPROXIMATE OIL CAPACITY QUARTS / LITERS		PORT SIZE INCH / MM	MAX. RPM	APPROXIMATE WEIGHT LBS. / KG	
	VERTICAL	HORIZONTAL			VERTICAL	HORIZONTAL
400 400BP	1 / 0.95	0.5 / 0.47	4 / 100 2 / 51	3600	195 / 90 400 / 180	180 / 90 N/A
540 720 720BP	1.5 / 1.42	1 / 0.95	4 / 100 4 / 100 2.5 / 63.5		260 / 120 300 / 135 560 / 255	240 / 110 280 / 130 N/A
850 1600 2000 2700	4 / 3.79	2.5 / 2.37	** 6 / 150 10 / 250		430 / 195 580 / 265 685 / 310 790 / 360	450 / 205 540 / 245 645 / 295 750 / 340

** Horizontal flow units are available with 6" (150 mm) ports on inlet and discharge as standard. Vertical flow units have 6" (150 mm) on top and 3" (80 mm) on bottom.

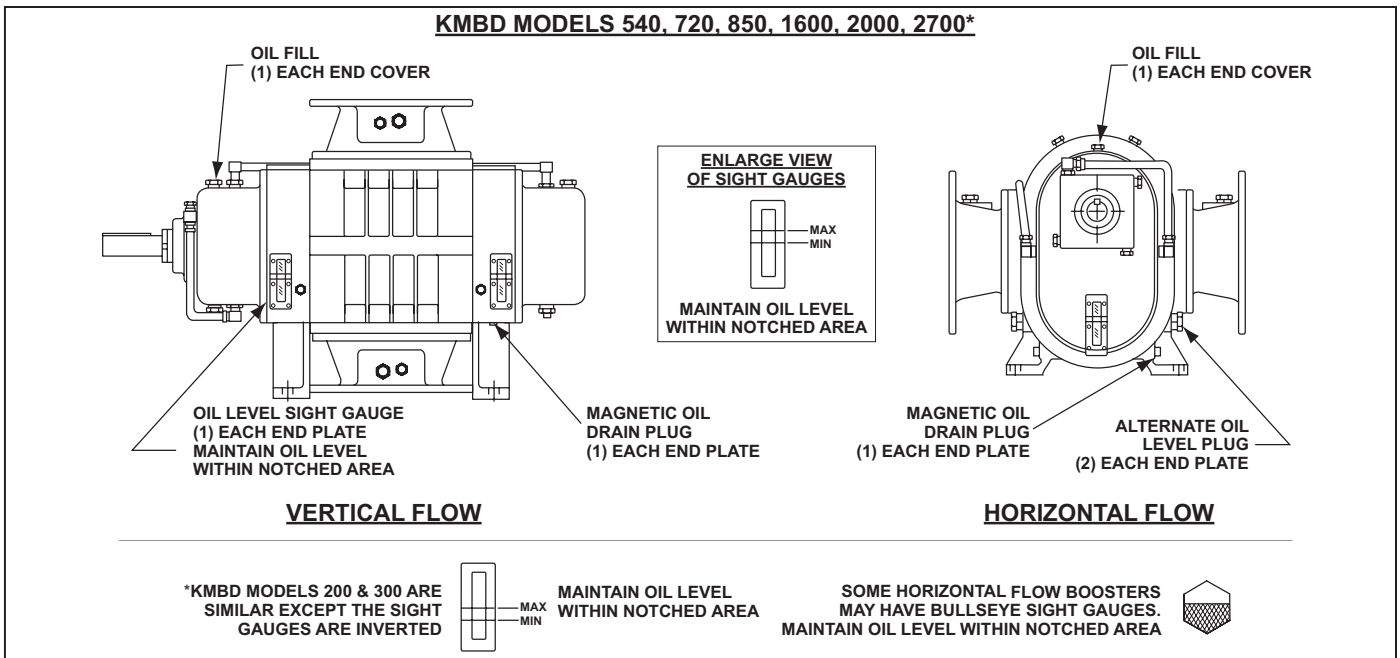

Figure 2 - Location of oil fill, drain and level plugs and level gauges

Kinney KV-100 oil is recommended for use on boosters with typical vacuum applications. Consult Tuthill Vacuum & Blower Systems about oils for use where hazardous or chemically active materials may be present. NOTE: See "Frequently Asked Questions" on page 15 for additional information regarding lubrication.

Add vacuum oil to the booster in the quantity shown in Table 2. The oil level must be maintained within the notched area of the sight glass. See Figure 2. Lower drive units (horizontal flow) have "bull's eye" type oil level gauges. Maintain oil levels at the center of the glass. Oil may not be added while booster is operating. Oil reservoirs are under vacuum.

PIPING CONNECTIONS

Manifolding should be no smaller than the pump connections in order to minimize restrictions to gas flow. Accurately align the mating flanges to the inlet and discharge manifolding to prevent distortion of the booster housing. Temporarily fit a fine wire mesh filter at the suction port if solid particles are likely to be entrained into the air stream and remove the filter when particles no longer appear. This is especially desirable on new installations and when manifolds have been welded. The manifolding to and from the booster should be fitted with flexible connections to isolate vibrations, absorb expansion and contraction due to thermal change, and to absorb misalignment differences. If the booster is to be water cooled, connect a clean supply to the 1/4" NPT connection on the seal adapter housing adjacent to the drive shaft. The drain line will be connected on the bottom of the non-drive end reservoir, see Figure 3 for connection locations.

The partly water-cooled slinger version has cooling water to the seal adapter housing only. The cooling coils and interconnecting water line are omitted and the interconnecting line leading from the seal adapter housing is led to the drain.

The air-cooled configuration requires no cooling water. However, cooling water can be circulated through the seal adapter housing on most models without modification to the booster. Cooling the bearing housing will prolong the life of the mechanical seal therein.

An on-off valve should be provided on the incoming line and a regulating valve located in the drain line. The drain line should terminate at an open drain to enable the operator to better regulate the water flow.

Units that will operate with continuous discharge gas temperatures of 250° F (121° C) or more must be connected to a water (liquid) supply in order to maintain reasonable oil temperatures. Generally a water flow of ½ to 1 GPM (1.9 - 3.8 L/min) is sufficient to maintain oil temperatures below 150° F (65° C).

WARNING: If unit is to be located outside or in a building where ambient temperatures can fall below freezing then care must be taken to ensure the water or liquid used for cooling does not freeze and damage the booster. Booster must be drained of liquid during downtime unless a recirculating unit using a glycol mixture has been installed.

NOTE: Units are never shipped from the manufacturer with liquid in the coiling coils.

COOLING WATER SPECIFICATIONS

Flow rate: Less than 2 GPM (7.6 L/min) total for both end plates.
Maximum Pressure: 100 PSIG (6.895 bar G)

MOTOR DRIVES

Two drive connections commonly used are direct drive and V-belt drive.

DIRECT COUPLED

When installing the motor directly to the booster, align shafts to coupling in accordance with the coupling manufacturer's instructions. Boosters shipped with motor directly coupled and mounted on a common base have been aligned prior to shipment and normally no further alignment is necessary. However, alignment should be checked and adjustments made if necessary prior to starting the unit.

V-BELTS

If the motor and booster are V-belt connected, the sheaves on both motor and booster shafts, should be as close to the shaft bearings as possible. Properly align the sheaves. V-belts should be replaced in matched sets and the sheaves should be positioned so as to allow the belts to be placed in the grooves without rolling them onto the sheaves. The following tensioning steps can be safely followed for all belt types, cross sections, number of belts per drive, or type of construction.

1. With belts properly in their grooves adjust the sheaves until all slack has been taken up.
2. Start the drive and continue to tension the V-belt(s) until only a slight bow on the slack side of the drive appears while operating under load conditions.
3. After 24 to 48 hours of operation the belts will seat in the sheave grooves. Further tensioning is then necessary as described in Step 2. Insufficient tensioning is often indicated by slipping (squealing) at start up. Belt dressing should not be used on V-belts. Sheaves and V-belts should remain free of oil and grease. Tension should be removed from belts if the drive is to be inactive

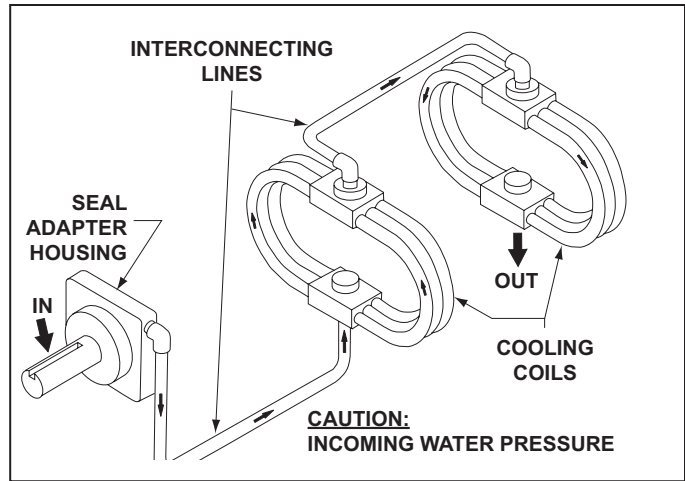

Figure 3 - Cooling Water Piping Harness

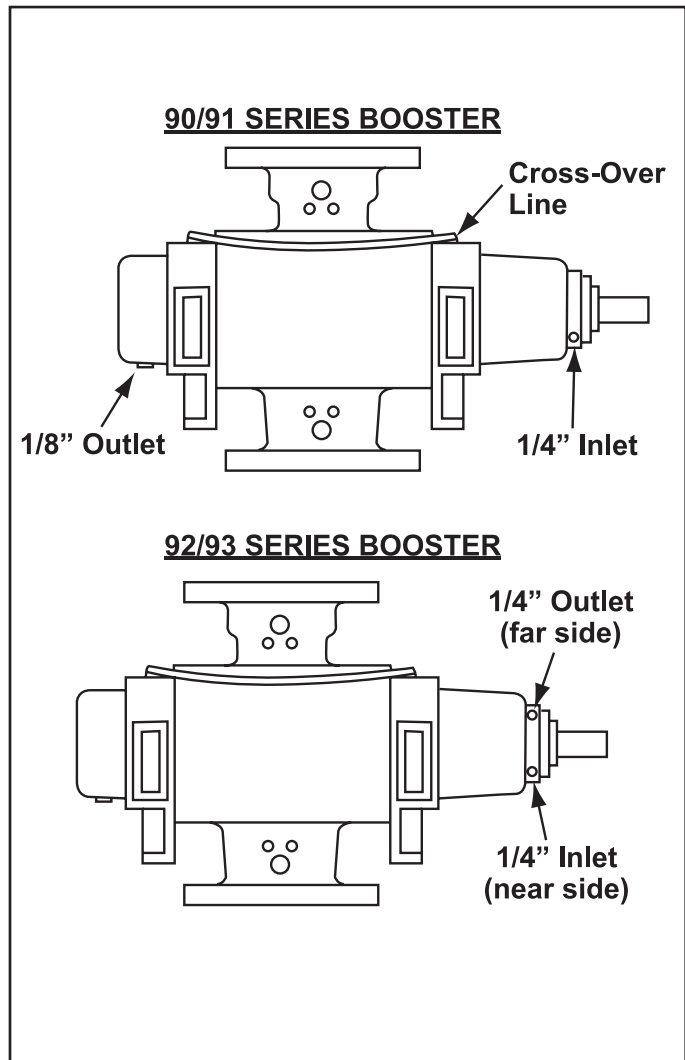

Figure 4 - Cooling Connections Types & Configurations

for an extended period of time. For more specific information consult the drive manufacturer.

ELECTRICAL CONNECTIONS

Wire the motor and other electrical devices such as solenoid valves and temperature switch to the proper voltage and amperage as indicated on the nameplate of each component being wired. Turn the booster by hand after wiring is completed to determine that there are no obstructions and if the booster turns freely; then momentarily start the booster to check the direction of rotation. Figure 5 shows direction of air flow in relation to rotor rotation. The air flow direction can be reversed by reversing the appropriate motor leads.

OPERATION

STARTING

Check the oil for proper level at both ends of the booster. Add, or drain, oil as necessary to bring the oil to the correct level. See Figure 2. Too much oil particularly on the gear end can result in excessive heat generation. Too little oil will possibly result in failure of the timing gears, bearings, and mechanical seals.

Start the backing pump. When pressure

is reduced sufficiently, start booster pump. A pressure switch can be installed to start the booster at a predetermined pressure. If the booster is water cooled turn on the cooling water when the booster is started. Adjust the water flow so that the discharge water temperature is no more than lukewarm (70° to 80° F [21° to 26° C]).

OPERATING

The upper temperature limits for booster pump operation are between 350° to 375° F (175° to 190° C) measured in the exhaust gas stream with a low mass thermocouple. When this temperature limit switch is installed, as the temperature exceeds the predetermined temperature, the booster motor will stop and cannot be restarted until the temperature drops below the trip setting of the temperature switch.

NOTE: These upper limits are not for continuous operation. Consult with factory for detailed information or assistance.

STOPPING

CAUTION: Venting the booster to pressures above cut-in while running can damage the pump.

Stop the booster by turning off the motor. Isolate the booster from the vacuum system and vent the booster to atmosphere. Turn off the cooling water if water cooled. Stop the backing pump. Refer to component instruction manual.

MAINTENANCE

GENERAL

Scheduled maintenance consists of changing lubricating oil every 250 to 1500 hours of operation. Change the oil more frequently if

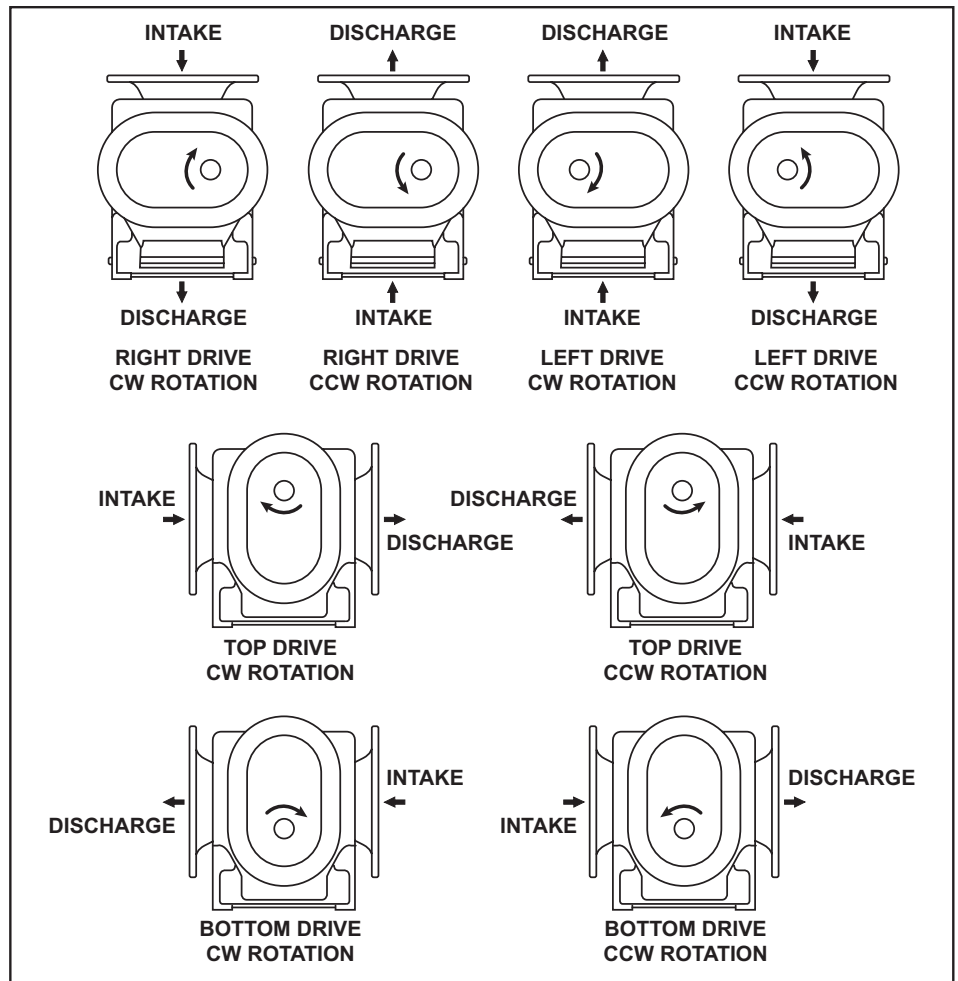

Figure 5 - Flow Direction by Rotation

pumping corrosive vapors or where excessive operating temperatures are encountered. Boosters with mechanical seals on the rotors can generally run the full 1500 hours before an oil change is required.

Proper oil drain schedules require oil be changed before the contaminant load becomes so great that the lubricating function of the oil is impaired or heavy disposition of suspended contaminants occurs. To check the condition of the oil, drain a sampling into a clean container and check for the presence of water or solids. Slight discoloration of the oil should not necessitate an oil change.

NOTE: When changing oil be sure to reseal the drain and fill plugs. This is especially important on 92/93 series which have no mechanical seals on the rotors. Air leaks past these plugs can cause rapid loss of oil from end covers resulting in booster failure.

NOTE: Oil levels should be checked every 24 hours of operation.

SPARE PARTS

Refer to the parts list and exploded view for your particular model. Repair kits are available for all models. These kits contain all of the seals, bearings, O-rings, locks and special retaining screws necessary for an overhaul. Always have the complete booster model number and serial number when ordering.

In developing a stock of spare parts, consider the following:

- The degree of importance in maintaining the booster in a "ready" condition
- The time lag in parts procurement
- Cost
- Shelf life (seals and O-rings)

Contact Tuthill Vacuum & Blower Systems Service Department for any assistance in selecting spare parts.

Telephone: (417) 865-8715

Toll Free (48 contiguous states): (800) 825-6937

Facsimile: (417) 865-2950

REPAIR SERVICE

With proper care, Tuthill Vacuum & Blower Systems Mechanical Vacuum Boosters will give years of reliable service. The parts are machined to very close tolerances and require special tools by mechanics who are skilled at this work. Should major repairs become necessary, it is strongly recommended that the booster be returned to the factory for repair or to one of the authorized service facilities that specialize in vacuum booster repair. Contact the factory for the location nearest you. Units which are still under warranty must be returned to the factory, freight prepaid, for service.

DISASSEMBLY — KMBD-200, 400

NOTE: Items shown in brackets [] are referenced to item numbers shown on page 22.

1. Disconnect cooling water lines [274 & 181]. Do not disturb cover bushings [120] or it will be necessary to retest cooling coils for leakage as described in the assembly procedure. Covers should be retested if water is detected in drain oil. (90/91 series only).
2. Drain oil from both ends of booster and remove inlet and outlet port fittings [38 or 48].
3. Remove spanner lock nut [83], dust washer [82], screws [93], and seal adapter housing [91]. Tap out seal [76] and discard O-rings [92 & 140]. Remove spacers [77 & 74], adjusting shim [118] and discard O-ring [75].
4. Remove cap screws [26A & 26B] and both end covers [6 & 7]. Two jack screw holes are provided on each cover.
5. Remove lockwire [49], socket head screws [66], and drive shaft [45]. Using puller, remove bearing [50].
6. Remove flat head Allen screws [29] from end of each rotor shaft. Remove washers [25], spacers [57], and oil slinger [21]. NOTE: The flat head screws have nylok in their threads and may be difficult to remove. Strike the head a couple of blows with a flat face hammer for easy removal.
7. Mark housing, end plates, rotors, and gears before proceeding with disassembly. There are two methods which can be used to disassemble the rest of the unit. Method "A" requires an arbor press and method "B" requires the use of bar or yoke pullers. See puller drawing (T29603) on page 29.
8. Method A:
 - a. Place two support blocks, 5-1/2 to 6 inches (14 to 15.5 cm) high (hard wood or steel), on the bed of an arbor press. Set the unit, with the gears pointing down, on the two blocks making sure the blocks support the rotor housing only. Press both rotors out of free end bearings simultaneously.
 - b. Lift the housing off the rotors and remove the non-drive end plate [4] by tapping the end plate from the inside of the housing. Place the rotor housing back over the rotors.
 - c. Set the unit on the support blocks with the gears pointing upward. Do not extend blocks into the rotor bores. The rotors may now be pressed from the gear end plate. Do not damage rotors.

Method B:

- a. Align timing marks on gears (Figure 6A). Rotate drive gear clockwise approximately three teeth and mark a matching reference line on each gear as shown in Figure 6B. This gear position is necessary so rotors will clear and not jam. Do not allow the gears to move from the matched reference line while pulling. Use a light rocking motion to insure that the lobes have

not jammed. Remove driven gear first then drive gear. **WARNING:** Failure to properly pull this gear could result in damage to rotor keyway or a bent rotor shaft. Never use excessive force.

- b. Remove button head Allen screws [30] and bearing retainer rings [14] from both end plates.
 - c. Attach a pair of bar pullers to the bearing bores of the free end plate. Use 10-32 x 4" long screws (no metric equivalent) Alternately push both rotors from end plate. Separate end plate from housing.
 - d. Turn the unit around and attach a single bar puller to either bore and push rotor from end plate making sure the rotor is vertical in the housing (for support) while removing. Repeat for opposite rotor. Note location of timing shims [16], oil slinger [20], and spacers [17 & 18].
 - e. Tap end plate from housing.
9. Mechanical Seal Series - Tap out bearings from both end plates. Note location of spacers under bearings and retain for reassembly. To remove seals [54] use a cape chisel or similar tool being careful not to nick or cut the bearing or seal bores. Remove the labyrinth seal [51] in the same manner. The seals will be damaged by removal and must be replaced. 92/93 Series - Carefully tap out seal slinger [238], spacer [123], and bearings. The oil slinger stator [79] should not be removed unless it is damaged or the end plate is to be replaced. **NOTE:** On some older units the oil seal slinger is made up of two separate parts, items 238 & 129. The newer design combines these two parts and is identified as item 238.
10. Clean all parts with good grade of clean solvent and replace any worn or damaged parts with factory approved parts. New bearings, seals, and O-rings should be installed at each assembly.

ASSEMBLY — KMBD-200, 400

GENERAL

NOTE: Items shown in brackets [] are referenced to item numbers shown on page 18.

The assembly procedure is generally the same for all series, but where there are differences, notations will be made. All vacuum joints, end covers, seal casings and plugs should be sealed with an RTV Silicone Sealer or equal, unless O-rings have been provided. Dowel pins are used to locate end plates, housing, and drive end cover in the proper location relative to each other. Be sure they are in place.

It is recommended that the gear end rotor shaft bearings be purchased from Tuthill Vacuum and Blower Systems, as they are specially ground to locate the rotors with correct end clearance relative to the gear end plate. Do not use standard bearings which have not been flush ground within .001" (.025 mm) tolerance. Use factory approved parts.

It is suggested that long feeler gauges (12" or 30 cm) be used to check the interlobe timing, preferably (2) .006" (.15 mm), (1) .005" (.13 mm), (1) .004" (.10 mm), and (1) .003 (.08 mm). This will give you all the combinations from .003" (.08 mm) to .021" (.53 mm) and also .024" (.61 mm) which is the total.

PREPARATION OF END PLATES FOR ASSEMBLY:

1. Remove all nicks, scratches, etc. from all sealing surfaces. Clean all parts thoroughly. See seal pressing tool drawing (T32018) on page 27.
2. Mechanical Seal Series - Press in new labyrinth seals [51] into bores of both end plates [4] making sure the scalloped areas of seal case are aligned with openings in vent area of seal bore. Coat O.D. of mechanical seal with sealer and press into seal bore, coming to rest on top of labyrinth seal. Make sure seals are fully seated without deforming case. Keep sealer from carbon surface. Carefully wipe carbon with soft tissue and cleaning agent (acetone) before continuing assembly. Slinger Seal Series - Press in new oil slinger stators [79] if required.

GEAR END ASSEMBLY:

3. Stand rotors [1] on arbor press table with gear end shafts up. See Figure 7. Two keyways should point in the same

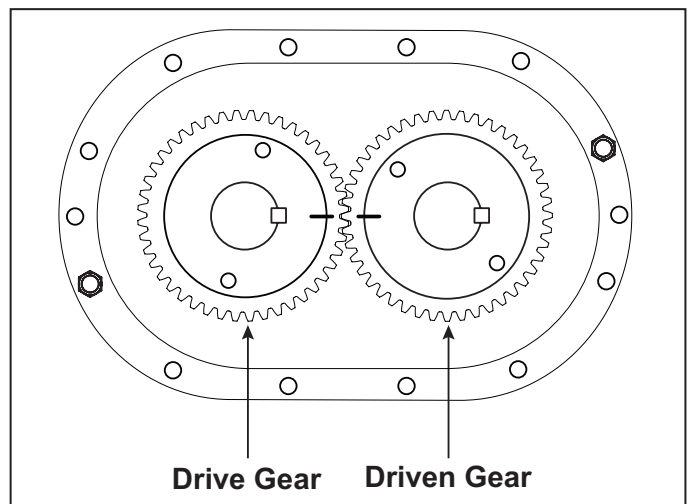

Figure 6A - Keyways in line and timing marks matched

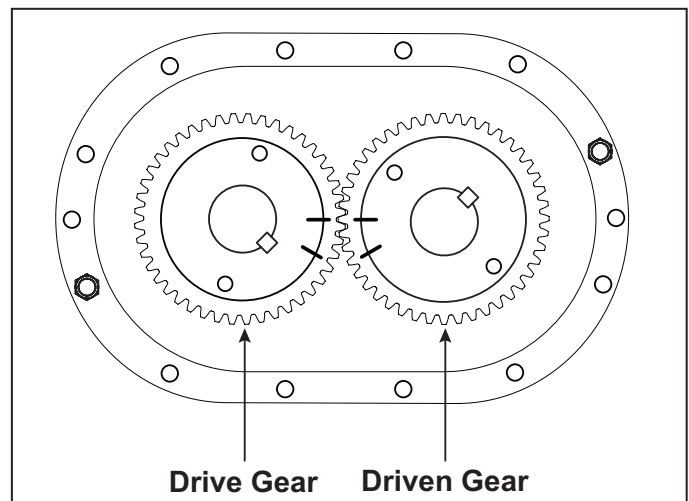

Figure 6B - Timing marks advanced 3 teeth
(Reference marks aligned)

direction, to the right.

- Carefully install gear end plate over rotor shafts. NOTE: The drive rotor should always be on the left side. Make sure the end plate feet are facing in the proper direction so the assembled unit will have the same drive shaft location as before.
- Mechanical Seal Series - Some earlier models used an O-ring [314] under the mating portion of the mechanical seal. This has been discontinued and O-rings should not be used with newly purchased seals. Check lapped surface of seal mating ring to be sure it is perfectly clean. Use soft tissue and cleaning agent if necessary. Place a few drops of lubricating oil on its surface and install on shaft with lapped surface coming to rest on top of carbon. Gently press with fingers to insure compression is taking place and ring is not hung up for any reason.
Slinger Seal Series - Slide seal slinger [238] over shaft. Also install spacer [129] if two piece.
- Lubricate shafts and press the double row ball bearings [9] onto rotor shafts and into end plate bores. CAUTION: These bearings have been flush ground at the factory. The inner race will have a black dot etched on the surface. This dot must be up and visible when bearings are installed. Secure with bearing retainers [14], and socket head screws [30].
- Check clearance between the face of the end plate and rotor lobes. See Clearances table on page 16 for correct gear end clearances. If clearances are not within specifications, recheck parts to find cause of improper clearances before proceeding.

INSTALLATION OF TIMING GEARS:

- Install spacer [17] (.260" {6.60 mm} thickness) on one shaft, and spacer [18] (.200" {5.08 mm} thickness) and oil slinger [20] on the other shaft. NOTE: Oil slinger and its spacer should always be mounted on lower rotor for horizontal flow units. It can be mounted on either shaft for vertical flow units. Install timing shim in same location as found in disassembly. This does not necessarily insure the unit will be in proper time. Adjustments can be made later in the assembly process.
- Insert gear keys [24] in their proper location and flush with top of shaft. Use the two keyways facing to the right. A tight fit is required. Coat shafts and keys with lubricant. Install drive gear (right hand helix) on drive rotor (left side). To install driven gear, align reference marks as shown in Fig. 6B. Install driven gear carefully to avoid damaging any teeth when engaging opposite gear. Secure with spacers [57], washers [25], and flat head Allen screws [29]. NOTE: All timing gears must be used in sets, as they are matched and serially numbered.
- Remove assembly from press and stand on work table with gears down. Place blocks under end plate to prevent assembly from falling over. Drive gear should remain on left side.

HOUSING AND FREE END ASSEMBLY:

- Place a small bead of sealer around the periphery of the end plate, encircling each bolt hole. Install rotor housing [3] and secure with 4 screws evenly spaced.
- Check clearance between end of lobes and housing using a flat bar and feeler gauges or a depth micrometer. Refer to Clearances table on page 16 for free end clearances.
- Place a small bead of sealer around the periphery of the housing, encircling each bolt hole. Install free end plate and secure with 4 screws.
- Mechanical Seals - Install mating rings same as gear end, No. 5. 92/93 - Install seal slinger same as gear end.
- Install bearing spacers [123] on each shaft. Lubricate shafts and install roller bearings [10]. CAUTION: Inner race of bearing has a flange on one side only. This flange must face outward. See Figure 10.
- Install oil retainer rings [14] with button head screws [30]. Only two required for each ring.

ADJUSTING ROTOR INTERLOBE CLEARANCE:

- Install spacer [67] on each shaft. Install oil slinger [21] on lower rotor, (either shaft on vertical flow units) spacer [57] on opposite shaft, washers [25], and screws [29]. Lay assembly down with drive on left for timing.
- Using feeler gauges take interlobe readings and record on each side of housing as indicated in Figure 8. By removing or adding shim behind the helical gear, it rotates as it is moved in or out and the driven rotor turns with it, thus changing the clearance between rotor lobes. Changing the shim thickness .006" (.15 mm) will change the rotor lobe clearance .003" (.08 mm) or one-half the amount.

EXAMPLE: Referring to Figure 8, check the clearance a AA (right hand reading) and BB (left hand reading). If AA reading is .009" (.23 mm) and BB reading .003" (.08 mm) by removing .006" (.15 mm) shims, the readings will change one-half the amount removed or .003" (.08 mm) AA should then read .006" (.15 mm) and BB should read .006" (.15 mm). The final reading should be within .002" (.05 mm) of each other. To determine the amount of shim to add or remove, subtract the small figure from the larger. If the right side reading is higher than the left side, remove shim. If the right side reading is lower, add shim.

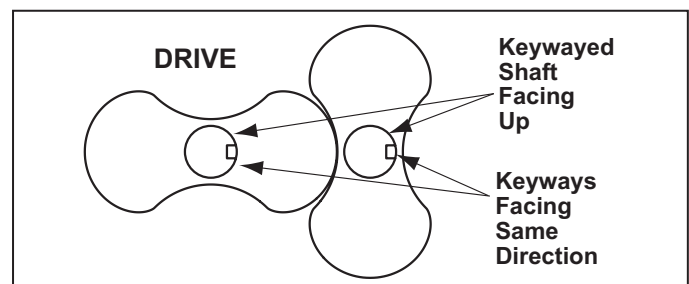

Figure 7 - Keyways

- Install drive shaft [45] and secure with Allen screws [66]. Check drive shaft runout behind keyway. Do not exceed .002" (.05

mm) T.I.R. Install lockwire [49].

20. Install bearing [50] on drive shaft with shield towards gear, and shim pack [118].
21. Remove temporary cap screws from gear end plate and apply a bead of sealer around end plate (not cover), encircling all holes, and install gear cover [6] and secure with cap screws [26A]. NOTE: If cooling coil or fittings were disturbed or water was detected in drain oil, they should be retested with air pressure to check for leaks and resealed. This applies to mechanical seal series only.

DRIVE SHAFT SEAL ASSEMBLY:

22. Grease and install O-ring [140] into groove of seal adapter housing [91]. Press in stator portion (carbon) of mechanical seal [76].
23. Install O-ring spacer [74], O-ring [75], and mating ring portion of mechanical seal, with lapped surface facing outward. Make sure surface is clean and place a few drops of lubricating oil on its surface. Install sleeve [77] with grooved side facing mating ring.
24. Slide seal assembly housing [91] over drive shaft and against cover. Slide dust washer [82] against spacer sleeve [77]. Dust washer should be flush to plus .005" (.13 mm) with face of housing. Adjust with shim pack [118].
25. Remove housing and install O-ring [92]. Reinstall housing [91], (with cut out on seal housing up when unit is standing on its feet) dustwasher [82] and secure with Allen screws [93] and spanner nut [83]. CAUTION: Do not hammer on wrench or use excessive force as distortion of mating ring may occur causing leakage.

COMPLETE BOOSTER ASSEMBLY:

26. Install free end cover [7] following the same procedure used to install the gear cover. Secure with cap screws [26B].
27. Apply sealer and install both port fittings [38 or 48].
28. Install all necessary cooling water lines.
29. Prior to putting booster into operation, follow Installation and Operation instructions. Observe the oil level frequently during the initial hours of operation. An improperly installed or damaged oil seal will result in oil loss.

DISASSEMBLY — KMBD-540, 720, 850, 1600, 2000, 2700

NOTE: Items shown in brackets [] are referenced to item numbers shown on page 21 and 24.

1. Disconnect cooling water lines [274 & 181]. Do not disturb the large hex head screw [97]. If it is removed, loosened, or water is detected in drain oil, the coil assembly must be retested as described in the assembly procedure.
2. Drain oil from both ends of booster and remove port fittings [38 or 48].
3. If you anticipate overhauling more than one unit of the same size, it will be to your advantage to machine a post to disassemble and assemble the drive shaft seal assembly, separate from the unit. Dimensional drawings for this post are on page 28 (T22179 used for models 540 and 720) or page 29 (T22180 used for models 850, 1200, 1600, 2000, and 2700). Remove the four screws [93], loosen set screws [90], and slide the entire assembly off the shaft. Continue below for the alternate method.
4. Remove spanner lock nut [83].
5. Loosen both set screws [90] and slide off lock ring [89].
6. Remove four socket head screws [93] and seal housing [91]. Two pry slots have been provided. Dust washer [82] will slide off with housing.
7. Tap out seal [76] and remove O-rings [140 & 92].
8. Remove sleeve [77] and slide adapter sleeve [87] from shaft.
9. Remove seal mating ring [76], seal spacer [74], and O-rings [75 & 88].
10. Remove cap screws [26] and gear cover [6]. Two jackscrew holes are provided on both covers.
11. Using bearing puller, remove drive shaft bearing [9 or 50], or press off after removing shaft. Retain bearing shim [86] for reassembly.
12. Remove drive shaft screws [66] and locks [65]. Tap shaft lightly to remove.
13. Remove gear lock nuts and washers [35 & 36]. Model 850, 1600, 2000, and 2700 series (top drive only). Remove cap screw [396] washers [136 & 80] and oil slinger [20] if furnished.
14. Position the timing gears for pulling by first matching the timing marks on the gears. See Figure 9A below. Turn the drive gear clockwise five teeth and mark a matching reference line on each gear as shown in Figure 9B below. The rotor lobes are now in their most open position. Using a gear puller, the driven gear (left hand helix) may now be removed without jamming the rotors. This gear is in two parts - the gear rim and hub. It is not necessary to disassemble. Do not allow the gears to move from the matched reference line while pulling. Use a light rocking motion while pulling the gear to insure that the lobes have not jammed.

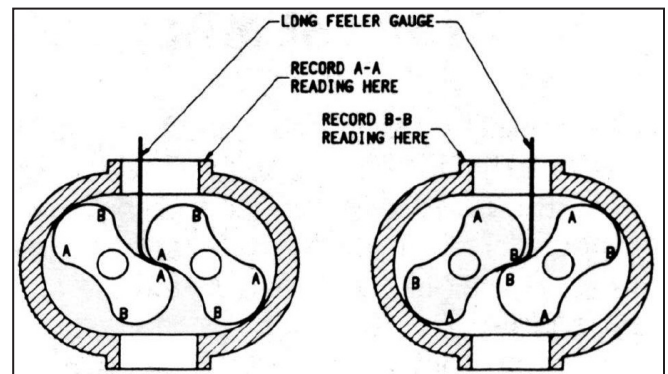

Figure 8 - Checking Rotor Interlobe Clearance

15. Remove drive gear. It is not necessary to remove keys from rotor shafts.
16. Remove cap screw [62], locks [61], and bearing lock rings [14].
17. Install two screws temporarily to hold end plate to housing. **WARNING:** Failure to properly pull this gear could result in damage to rotor keyway or a bent rotor shaft. Never use excessive force.
18. Remove the free end cover [7], rotor shaft socket screws [26 & 69], washer [25], spacer [57], oil slinger [21] (must be pried off on models KMBD-850, 1600, 2000, and 2700), roll or dowel pin [68], socket head screws [30] and oil retainer rings [14 or 15]. **NOTE:** On KMBD-540 and KMBD-720, it is not necessary to remove item 15 unless the end plate is being replaced. **NOTE:** The flat head screws have nylok in their threads and may be difficult to remove. Strike the head a couple of blows with a flat face hammer for easy removal.
19. Using two yoke style pullers with pressure screws attached to free end plate bores, pull end plate from housing. Dimensional drawings for the pullers are on page 29 (T29603-1). Tap out the bearings [10]. Mechanical Seal Series - Tap out mechanical seal [54], spacers [123], and labyrinth seal [51]. Slinger Seal Series - Tap out seal slinger [238] and spacers [123]. The oil slinger stator [79] should not be removed unless it is damaged or the end plate is to be replaced. **NOTE:** On some older units the oil seal slinger is made up of two separate parts - items 238 & 129. The newer design combines these two parts and is identified as item 238.
20. Using a single yoke puller with longer screws, push out one rotor at a time making sure the rotor is vertical in the housing (for support) while removing.
21. Remove the two temporarily installed screws and tap gear end plate from housing and remove bearings and seals.
22. Clean all parts with a good grade of clean solvent and replace any worn or damaged parts with factory approved parts. New bearings, seals, and O-rings should be installed at each assembly.

ASSEMBLY — KMBD-540, 720, 850, 1600, 2000, 2700

GENERAL

The assembly procedure is generally the same for all series, but where there are differences, notations will be made. All vacuum joints, end covers, seal casings, and plugs should be sealed with an RTV Silicone Sealer equal, unless O-rings have been provided.

Dowel pins are used to locate end plates, housing, and drive end cover in the proper location relative to each other. Be sure they are in place.

It is recommended that the gear end rotor shaft bearings be purchased from Tuthill Vacuum & Blower Systems, as they are specifically ground to locate the rotors with correct end clearance relative to the gear end plate. Do not use standard bearings which have not been flush ground within .001" (.025 mm) tolerance. Use factory approved parts.

It is suggested that long feeler gauges (12" or 30 cm) be used to check the interlobe timing. Preferably (2) .006" (.15 mm), (1) .005" (.13 mm), (1) .004" (.10 mm), and (1) .003" (.08 mm). This will give you all the combinations from .003" (.08 mm) to .021" (.53 mm) and also .024" (.61 mm) which is the total.

PREPARATION OF END PLATES FOR ASSEMBLY

1. Remove all nicks, scratches, etc. from all sealing surfaces. Clean all parts thoroughly. Dimensional drawings for seal pressing tools are on page 27 (T11549 used for models 540 and 720) or page 28 (T11449 used for models 850, 1200, 1600, 2000, and 2700).
2. Mechanical Seal Series - Press in new labyrinth seals [51] into bores of both end plates [4] making sure the scalloped areas of seal case are aligned with openings in vent area of seal bore. Coat O.D. of mechanical seal with sealer and press into seal bore, coming to rest on top of labyrinth seal. Make sure seals are fully seated without deforming case. Keep

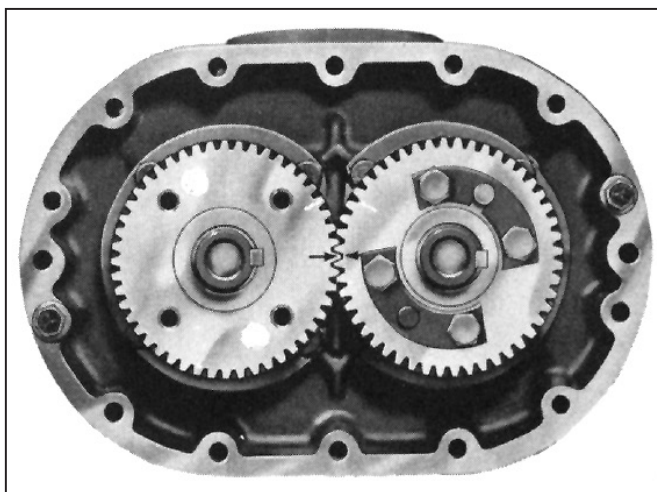

Figure 9A - Keyways in line and timing marks matched

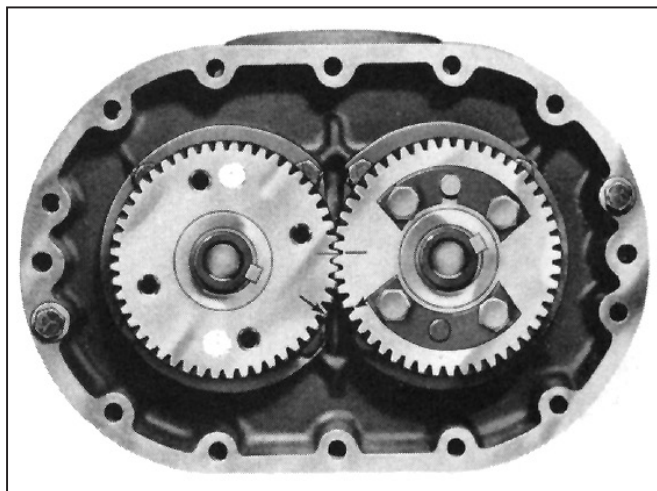

Figure 9B - Timing marks advanced 3 teeth
(Reference marks aligned)

sealer from carbon surface. Carefully wipe carbon with soft tissue and cleaning agent (acetone) before continuing assembly. Slinger Seal Series - Press in new oil slinger stators [79] if required.

- Stand rotors [1] on arbor press table with gear end shafts up. See Figure 10. Two keyways should point in the same direction, to the right.
- Carefully install gear end plate over rotor shafts. NOTE: The drive rotor should always be on the left side. Make sure the end plate feet are facing in the proper direction so the assembled unit will have the same drive shaft location as before.
- Mechanical Seal Series - Check lapped surface of seal mating ring to be sure it is perfectly clean. Use soft tissue and cleaning agent if necessary. Place a few drops of lubricating oil on its surface and install on shaft with lapped surface coming to rest on top of carbon. Gently press with fingers to insure compression is taking place and ring is not hung up for any reason. Slinger Seal Series - Slide seal slinger [238] over shaft. Also install spacer [129] if two-piece.

GEAR END ASSEMBLY

- Lubricate shafts and press the double row ball bearings [9] onto rotor shafts and into end plate bores. CAUTION: These bearings have been flush ground at the factory. The inner race will have a black dot etched on the surface. This dot must be up and visible when bearings are installed. Secure with bearing retainers [14] or [14 & 15] on KMBD 540 and KMBD-720, locks, and cap screws [61 & 62].
- Check clearance between the face of the end plate and rotor lobes. See Clearances table on page 16 for correct gear end clearances. If clearances are not within specifications, recheck parts to find cause of improper clearances before proceeding

INSTALLATION OF TIMING GEARS

- Insert gear keys [24] in their proper location. Use the two keyways facing to the right. A tight fit is required. Coat shafts and keys with lubricant.
- Install drive gear (right hand helix) on drive rotor (left side). To install driven gear, align reference marks as shown in Fig. 10B. Install driven gear carefully to avoid damaging any teeth when engaging opposite gear. Secure with gear lockwasher [36] and lock nut [35]. NOTE: All timing gears must be used in sets, as they are matched and serially numbered.
- Remove assembly from press and stand on work table with gears down. Place blocks under end plate to prevent assembly from falling over. Drive gear should remain on left side.

HOUSING AND FREE END ASSEMBLY

- Place a small bead of sealer around the periphery of the end plate, encircling each bolt hole. Install rotor housing [3] and secure with four screws evenly spaced.
- Check clearance between the end of lobes and the housing using a flat bar and feeler gauges or a depth micrometer. Refer to Clearances table on page 16 for free end clearances.
- Place a small bead of sealer around the periphery of the housing, encircling each bolt hole. Install free end plate and secure with four screws.
- Mechanical Seal Series - Install mating rings in the same way as the gear end, No. 5.
Slinger Seal Series - Install seal slinger in the same way as the gear end.
- Install bearing spacers [123] on each shaft. Lubricate shafts and install roller bearings [10]. CAUTION: Inner race of bearing has a flange on one side only. This flange must face outward. See Figure 10.
- Install oil retainer rings and screws [14 & 30], spacer [57] (Models 1600, 2000, 2700 only), washer [25], screw [29], oil slinger and dowel [21 & 68], and screw [69]. NOTE: Oil slinger should always be mounted on lower rotor for horizontal flow units. It can be mounted on either shaft for vertical flow units.
- Lay booster assembly down and torque timing gear nuts at this time. See Torque table on page 16 for proper torques.

ADJUSTING ROTOR INTERLOBE CLEARANCE

- The driven gear is made of two pieces. The outer gear shell is fastened to the inner hub with four cap screws and located with two dowel pins. A laminated shim, made up of .003" (.08 mm) laminations, separates the hub and the shell. By removing or adding shim laminations, the gear shell is moved axially relative to the inner hub. Being a helical gear, it rotates as it is moved in or out and the driven rotor turns with it, thus changing the clearance between rotor lobes. Changing the shim thickness .006" (.15 mm) will change the rotor lobe clearance .003" (.08 mm) or one half the amount.
- EXAMPLE: Referring to Figure 11, check the clearance at AA (right hand reading) and BB (left hand reading). If AA reading is .013" (.32 mm) and BB reading is .007" (.18 mm), by removing .006" (.15 mm) shims, the readings will change one half of the amount removed or .003" (.08 mm). AA should then read .010" (.25 mm) and BB should read .010" (.25 mm). The final readings should be within .002" (.05 mm) of each other.

To determine the amount of shim to add or remove, subtract the smaller figure from the larger. If the right side reading is higher than the left side, remove shim. If the right side reading is lower, add shim. When removing gear shell from driven gear, it is not necessary to remove gear lock nut. Make sure bolt locks are in place because the dowel pins must come off with the gear shell.

20. Bend over lock tabs of gear lockwasher [36] and gear screw locks. KMBD-1600, 2000, and 2700 only - Mechanical Seal series (top drive only). Reinstall oil slinger [20] to lower rotor and secure with washer [136 & 80] and cap screw [396], if furnished. Not used on older models.
21. Press on drive shaft bearing [9 or 50] (bearing shield must face outward - Models KMBD-200, 400, 2000, 2700 only) and install drive shaft with locks and screws [65 & 66], making sure both surfaces are clean and free of all burrs. Drive shaft runout should not exceed .003" (.08 mm) T.I.R. measured behind keyway. Bend over lock tabs.
22. Remove temporary cap screws from end plate and apply a bead of sealer around end plate (not cover), encircling all holes, and install gear cover [6] and secure with cap screws [26]. NOTE: If cooling coils or manifold screws have been disturbed, they should be retested with air pressure to check for leaks. If leaks occur, disassemble and replace O-rings [9 & 96]. Mechanical Seal series only.

DRIVE SHAFT SEAL ASSEMBLY

23. Install shim pack [86] on shaft. Install O-ring [140] in bottom of seal housing bore [91]. Press stator portion of mechanical seal [54 or 76] into bore until fully seated. Do not distort. Clean carbon surface with soft tissue and acetone.
24. The drive shaft seal assembly can be assembled using the fixture shown on page 28 (T22179 used for models 540 and 720) or page 29 (T22180 used for models 850, 1200, 1600, 2000, and 2700)
 - a. Slide threaded sleeve [87] on shaft or post. Install O-ring spacer [74].
 - b. Lubricate O-ring [75] and install in spacer groove. Make sure O-ring is fully seated in groove so it will not be pinched.
 - c. Clean mating ring [54] and place a few drops of lubricating oil on the lapped surface. Install with this surface out.
 - d. Install sleeve spacer [77] with groove side against mating ring.
 - e. Carefully install seal housing [91] over sleeve and temporarily secure with two screws.
 - f. Install dust washer [82], and lock ring [89] with two set screws [90]. One set of screws will pass through hole in sleeve and be positioned in keyway. Turn the other set of screws until it bottoms against sleeve. Do not tighten at this time.
 - g. Install spanner nut [83] with chamfer in, using spanner wrench.

CAUTION: Do not hammer on wrench or use excessive force. Distortion of mating ring may occur causing leak.

25. Mount assembly on shaft or proceed as follows: To set proper seal compression, apply thumb pressure to hold sleeve assembly against laminated shim. Using a depth micrometer, measure the difference between the seal dust washer and the face of the seal housing. Note this amount. The dust washer should be flush or .005" (.13 mm) below the housing. Add or remove the proper amount of shim to obtain this setting.
26. Remove assembly, lubricate and install the large O-ring [92] around the housing bore and the small O-ring [88] inside the sleeve bore. Check end of shaft and keyway. Remove all sharp edges so O-ring will not be cut when assembly is installed.
27. Install assembly with cut out on seal housing up when unit is standing on its feet. Brass elbow [152] should also be in place at this time. Secure with four screws [93]. Tighten both sets of screws [90].
28. Install free end cover [7] following the same procedure used to install the gear cover.

COMPLETE BOOSTER ASSEMBLY

29. Apply sealer and install both port fittings (38 & 48).
30. Install all necessary cooling water lines.
31. Prior to putting booster into operation, follow Installation and Operation instructions. Observe the oil level frequently during the initial hours of operation. An improperly installed or damaged oil seal will result in oil loss.

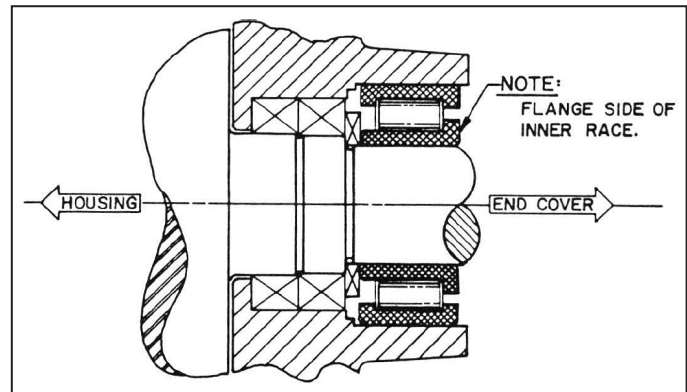

Figure 10 - Roller Bearing Flange

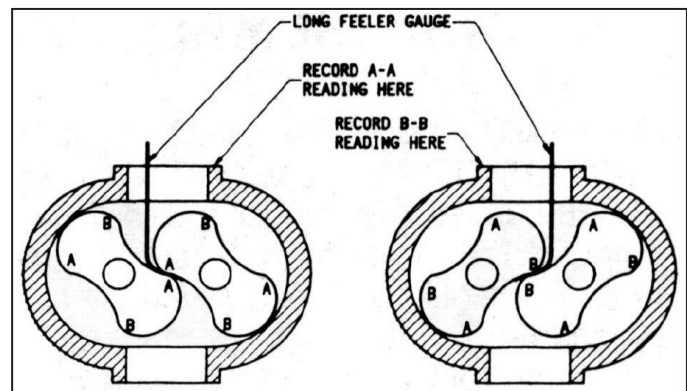

Figure 11 - Rotor Interlobe Clearance

FREQUENTLY ASKED QUESTIONS

What is the functional detriment if the "wrong oil" is used?

The lubricant is selected based on bearing and gear speed, and operating temperature. Too light of a lubricant increases wear by not separating the sliding surfaces and it will not remove the heat adequately. If the lubricant is too thick, the drag in the bearings

is increased causing them to run hotter. Since it is thicker, it will not flow as readily into the gears and it will reduce the available backlash. Lubricants at our conditions are incompressible.

What is the functional detriment if the oil is not serviced?

If the lubricant is not serviced at the proper interval the shearing action in the bearing and the gears will begin to take their toll and the lubricant will thicken, making matters worse. The unit will run hotter and the wear on running surfaces will increase. Generally, the lubricant will appear dirtier, this is actually material rubbed off the unit's components. The discoloration comes from overheating the additive package. An indicator of the breakdown of a lubricant is the increase in the TAN (Total Acid Number), and a change in the base viscosity of ten percent.

Several things are happening as the lubricant goes through the unit. First, it is absorbing frictional energy in the form of heat. This heat has to be dissipated through either surface contact with cooler materials, or in a rest volume of lubricant. While reducing the friction, the lubricant is also going through a shearing process and the molecular structure is broken down.

The result is that the lubricant will begin to thicken because of the shorter molecular chains and the drop out of additive packages. The thickened lubricant will cause more drag, increasing the friction and heat, and further degrading the lubricant.

Operation of the blower (environment, run time, speed, and pressure) has a direct effect on duty cycles. Our published cycles are based on worst-case conditions.

CLEARANCES

Values shown in inches and millimeters.

MODEL	GEAR END	FREE END	INTERLOBE	TIP-DOWEL	TIP-PORT
240C	.003 - .005 .08 - .13	.006 - .010 .15 - .25	CENTER TIMED	N/A	.0065-.0075 .165 - .190
400					
400C					
400BP					
540	.004 - .007 .10 - .18	.011 - .016 .28 - .41	CENTER TIMED	N/A	.006 - .011 .15 - .28
720					
720C					
720BP					
850	.004 - .007 .10 - .18	.011 - .016 .28 - .41	CENTER TIMED	.007 - .012 .18 - .30	.011-.016 .28-.41
1600 & C-face		.017 - .022 .43 - .56			
2000 & C-face		.021 - .026 .53 - .66			
2700		.025 - .030 .64 - .76		.008 - .013 .20 - .33	.012-.017 .30 - .43

TORQUE CHART

Values shown in foot-pounds (ft.-lbs) and Newton-meters (N-m).

PART DESCRIPTION	200	540	850
	400	720	1600 2000 2700
ROTOR SHAFT FLAT HEAD SCREW	35 47	35 47	90 122
1/4" CAP SCREW	10 13	—	—
5/16" CAP SCREW	17 23	21 28	—
3/8" CAP SCREW	—	42 56	42 56
1/2" CAP SCREW	—	—	90 122
TIMING GEAR SHAFT NUT	—	110 149	140 190
GEAR END BEARING RETAINER CAP SCREW	—	23 31	23 31
DRIVE SHAFT FLAT HEAD SCREW	—	35 47	35 47
BEARING RETAINER BUTTON HEAD SCREW	3 4	—	—

BYPASS MODELS - KMBD-400BP & KMBD-720BP

PUMP MODEL		KMBD-400BP	KMBD-720BP
Displacement	CFM	400	720
Inlet/Outlet	NPT	2	2
Motor	HP	3	5
Bypass valve		2	1-1/2
Valve item #		520356 B000	520357 B000
Tubing item #		520366 B000	520365 B000
Cracking pressure		50 Torr	50 Torr
Max. Pressure Diff.		75 Torr	75 Torr

These models are designed for applications such as vacuum packaging, where there is rapid cycling of evacuation of small volumes. They are similar to standard slinger seal models except that smaller suction and discharge connections are used and a bypass valve is fitted.

The smaller port sizes minimize the volume of the piping and results in the fastest possible evacuation of small volumes.

The purpose of the valve is to protect the booster from temporary fault conditions. The valve limits the pressure rise across the booster and thus shaft power and gas temperature rise.

To remove the valve loosen the two screws on the tube clamp below the valve and slide it clear of the gap in the bypass tube. Unscrew the valve from the top fittings.

Inspect the valve for contamination by process particulates or deposits. Disk (item 5), should move freely in guide (item 9). Mark the location of the cap before dismantling. It must be in the same position when the valve is reassembled. The caps (item 9), position sets the spring compression, and thus the valve cracking pressure.

NOTES: _____

KMBD-200 AND KMBD-300 PARTS LIST

ITEM NO.	PART DESCRIPTION	MECHANICAL SEAL	SLINGER SEAL
1	Rotor	2	2
3	Housing	1	1
4	End Plate	2	2
6	Drive End Cover	1	1
7	Free End Cover	1	1
8	Timing Gear Set	1	1
9	Bearing	2	2
10	Bearing	2	2
14	Bearing Retainer	4	4
16	Timing Gear Shim	1	1
17	Spacer	1	1
18	Spacer	1	1
19	Shims	2	2
20	Oil Slinger	1	1
21	Oil Slinger Assembly	1	1
22	Dowel Pins	6	6
23	Drive Shaft Key	1	1
24	Gear Key	2	2
25	Rotor Shaft Washer	4	4
26A	Cap Screw	12	12
26B	Cap SCrew	12	12
29	Flat Socket Screw	4	4
30	Socket Screw	12	12
31	Magnetic Pipe Plug	2	2
38	Port Fitting	1-0	1-0
40	Hex Head Cap Screw	AR	AR
45	Drive Shaft	1	1
48	Port Fltting	1	1
49	Lock Wire	1	1
50	Bearing	1	1
51	Labyrinth Seal	4	—
54	Mechanical Seal	4	—
57	Spacer	3	3
66	Screw	2	2
67	Spacer	2	2
74	Spacer	1	1
75	O-Ring	1	1

ITEM NO.	PART DESCRIPTION	MECHANICAL SEAL	SLINGER SEAL
76	Mechanical Seal	1	1
77	Spacer	1	1
79	Oil Retainer	—	4
82	Washer	1	1
83	Locknut	1	1
85	Pipe Plug	AR	AR
91	Seal Adapter Housing	1	1
92	O-ring	1	1
93	Screw	4	4
94	Cooling Coils	2	—
98	Pipe Plug	AR	AR
118	Shim	1	1
120	Bushing	4	—
121	Pipe Plug	2	2
123	Bearing Spacer	2	2
127	Socket Screw	—	2
129 *	Sleeve	—	4
137	Oil Deflector	—	1
140	O-ring	1	1
152	Elbow	1	—
165	Connector	4	—
166	Connector	3	—
174	Pipe Plug	2	2
180	Elbow	AR	—
181	Hose	1	—
238*	Slinger	—	4
241	Socket Screw	12	12
242	Sight Glass Frame	2	2
243	Sight Glass Window	2	2
244	Window Gasket	2	2
245	Frame Gasket	2	2
271	Pipe Plug	AR	—
272	Elbow	AR	—
273	Hose End	1	—
274	Hose	1	—

* Items 129 and 238 are now manufactured as a single part. Use item number 238 to order.
Parts kits are available, consult factory.

KMBD-540 AND KMBD-720 PARTS LIST

ITEM NO.	PART DESCRIPTION	MECHANICAL SEAL	SLINGER SEAL
1	Rotor	2	2
3	Housing	1	1
4	End Plate	2	2
6	Drive End Cover	1	1
7	Free End Cover	1	1
8	Timing Gear Set	1	1
9	Bearing	3	3
10	Bearing	2	2
14	Bearing Retainer	2	2
15	Oil Retainer Ring	4	4
16	Timing Gear Shim	1	1
21	Oil Slinger Assembly	1	1
22	Dowel Pins	6	6
23	Drive Shaft Key	1	1
24	Gear Key	2	2
25	Rotor Shaft Washer	4	4
26	Cap Screw	28	28
29	Flat Socket Screw	1	1
30	Socket Screw	4	4
31	Magnetic Pipe Plug	2	2
35	Gear Locknut	2	2
36	Gear Lockwasher	2	2
38	Port Fitting	2	2
40	Hex Head Cap Screw	AR	AR
45	Drive Shaft	1	1
51	Labyrinth Seal	4	—
54	Mechanical Seal	4	—
61	Lockplate	2	2
62	Cap Screw	8	8
65	Lockplate	2	2
66	Screw	4	4
68	Oil Slinger Pin	1	1
69	Flat Socket Screw	1	1
74	Spacer	1	1
75	O-Ring	1	1
76	Mechanical Seal	1	1
77	Spacer	1	1
79	Oil Retainer	—	4

ITEM NO.	PART DESCRIPTION	MECHANICAL SEAL	SLINGER SEAL
82	Washer	1	1
83	Locknut	1	1
85	Pipe Plug	AR	AR
86	Shim	1	1
87	Sleeve	1	1
88	O-ring	1	1
89	Spacer	1	1
90	Screw	2	2
91	Seal Adapter Housing	1	1
92	O-ring	1	1
93	Screw	4	4
94	Cooling Coils	2	—
95	O-ring	1	1
96	O-ring	4	—
97	Manifold Screw	4	—
98	Pipe Plug	AR	AR
121	Pipe Plug	2	2
123	Bearing Spacer	2	2
127	Socket Screw	—	2
137	Oil Deflector	—	1
140	O-ring	1	1
152	Elbow	1	—
166	Connector	3	—
174	Pipe Plug	2	2
180	Elbow	AR	—
181	Hose	1	—
238	Slinger	—	4
241	Socket Screw	12	12
242	Sight Glass Frame	2	2
243	Sight Glass Window	2	2
244	Window Gasket	2	2
245	Frame Gasket	2	2
271	Pipe Plug	1-0	—
272	Elbow	1-0	—
273	Hose End	1	—
274	Hose	1	—
Parts kits are available, consult factory.			

KMBD-850, 1600, 2000, AND 2700 PARTS LIST

ITEM NO.	PART DESCRIPTION	MECHANICAL SEAL	SLINGER SEAL
1	Rotor	2	2
3	Housing	1	1
4	End Plate	2	2
6	Drive End Cover	1	1
7	Free End Cover	1	1
8	Timing Gear Set	1	1
9	Bearing	2	2
10	Bearing	2	2
14	Bearing Retainer	4	4
16	Timing Gear Shim	1	1
21	Oil Slinger Assembly	1	1
22	Dowel Pins	6	6
23	Drive Shaft Key	1	1
24	Gear Key	2	2
25	Rotor Shaft Washer	1	1
26	Cap Screw	28	28
29	Flat Socket Screw	1	1
30	Socket Screw	6	6
31	Magnetic Pipe Plug	2	2
35	Gear Locknut	2	2
38	Port Fitting	1-2	1-2
40	Hex Head Cap Screw	AR	AR
45	Drive Shaft	1	1
48	Port Fitting	1-0	1-0
50	Bearing	1	1
51	Labyrinth Seal	4	—
54	Mechanical Seal	5	—
57	Spacer	1	1
61	Lockplate	6	6
62	Cap Screw	12	12
65	Lockplate	6	6
66	Screw	4	4
68	Oil Slinger Pin	1	1
69	Flat Socket Screw	1	1
74	Spacer	1	1
75	O-Ring	1	1
76	Mechanical Seal	—	1
77	Spacer	1	1
79	Oil Retainer	—	4
80	Washer	0-1	0-1

ITEM NO.	PART DESCRIPTION	MECHANICAL SEAL	SLINGER SEAL
82	Washer	1	1
83	Locknut	1	1
85	Pipe Plug	AR	AR
86	Shim	1	1
87	Sleeve	1	1
88	O-ring	1	1
89	Spacer	1	1
90	Screw	2	2
91	Seal Adapter Housing	1	1
92	O-ring	1	1
93	Screw	4	4
94	Cooling Coils	2	—
95	O-ring	4	—
96	O-ring	4	—
97	Manifold Screw	4	—
98	Pipe Plug	AR	AR
123	Bearing Spacer	2	2
129*	Sleeve	—	4
140	O-ring	1	1
152	Elbow	1	—
166	Connector	3	—
174	Pipe Plug	AR	AR
180	Elbow	AR	—
181	Hose	1	—
238*	Slinger	—	4
241	Socket Screw	12	12
242	Sight Glass Frame	2	2
243	Sight Glass Window	2	2
244	Window Gasket	2	2
245	Frame Gasket	2	2
271	Pipe Plug	AR	—
272	Elbow	AR	2
273	Hose End	1	—
274	Hose	1	—
500	Thermoswitch	1	1
* Items 129 and 238 are now manufactured as a single part. Use item number 238 to 28 order. Parts kits are available, consult factory.			

ASSEMBLY PRINTS FOR KMBD-200 AND 400
CUTAWAY VIEW

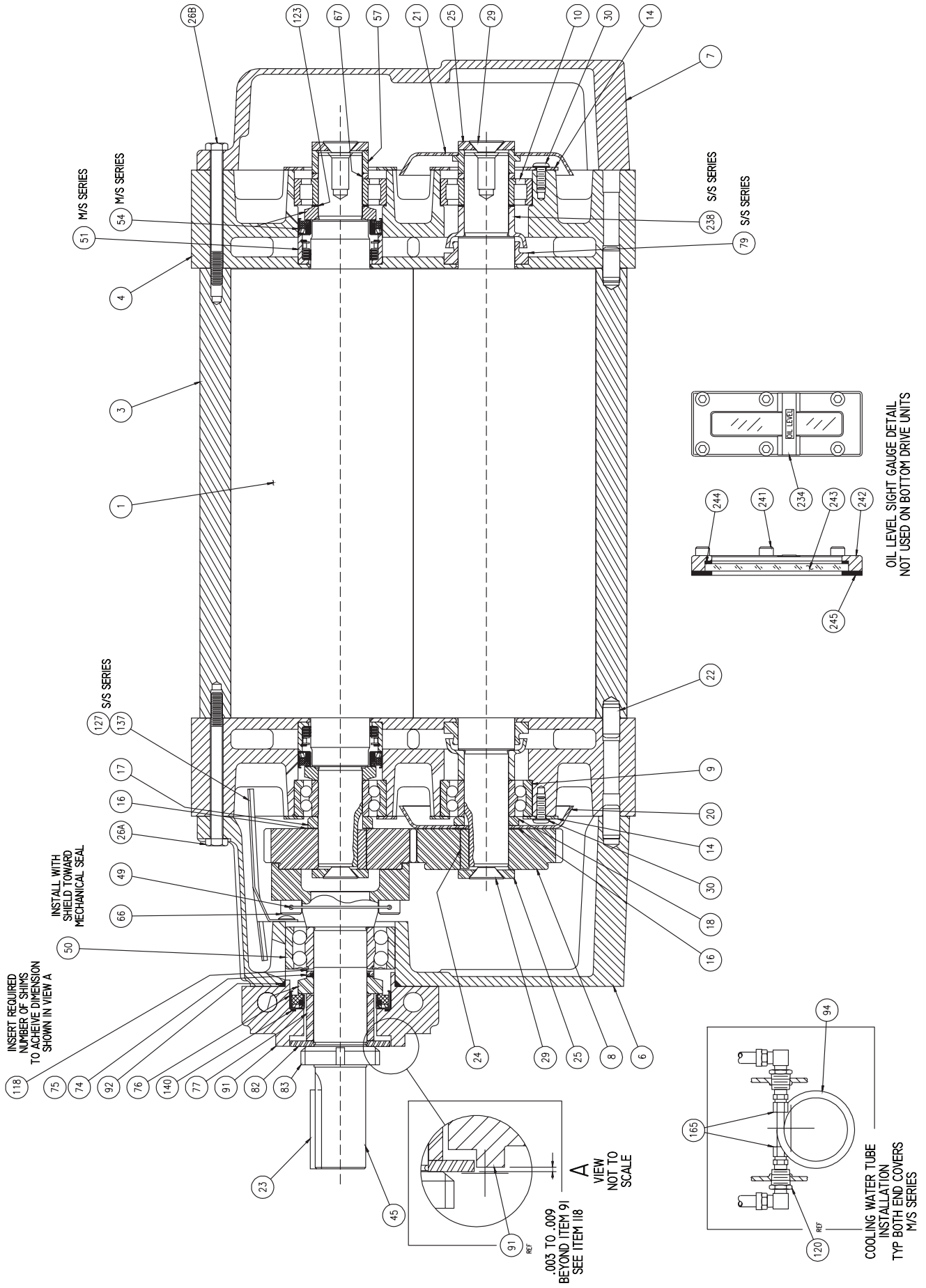

ASSEMBLY PRINTS FOR KMBD-200 AND 400
SIDE AND END VIEWS

VERTICAL FLOW - MECHANICAL SEAL

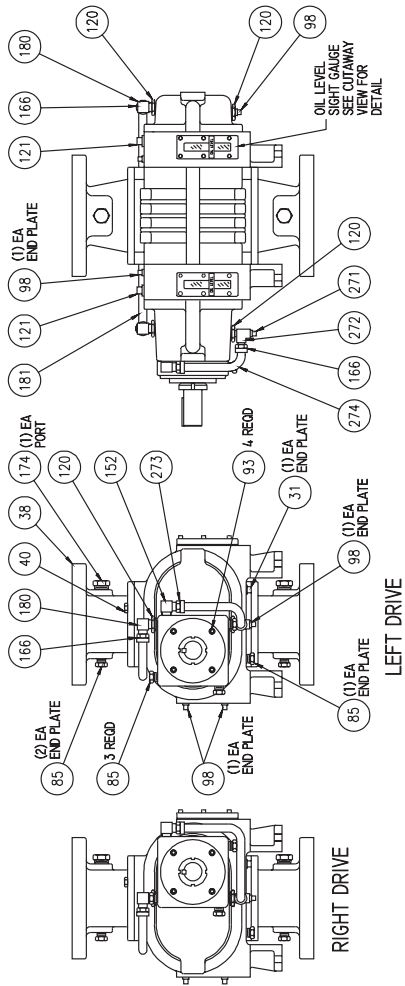

VERTICAL FLOW - SLINGER SEAL

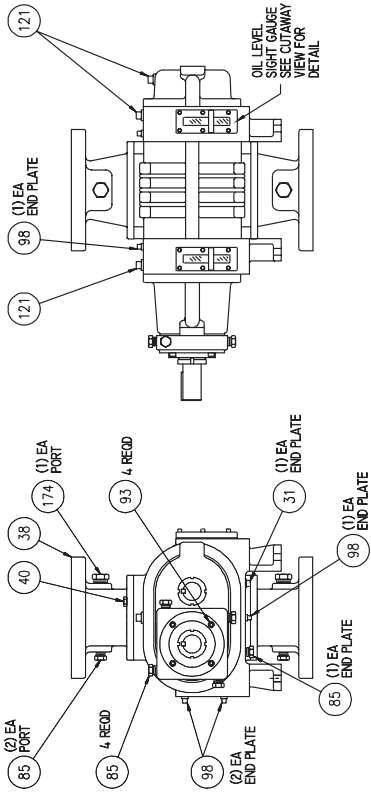

HORIZONTAL FLOW - MECHANICAL SEAL

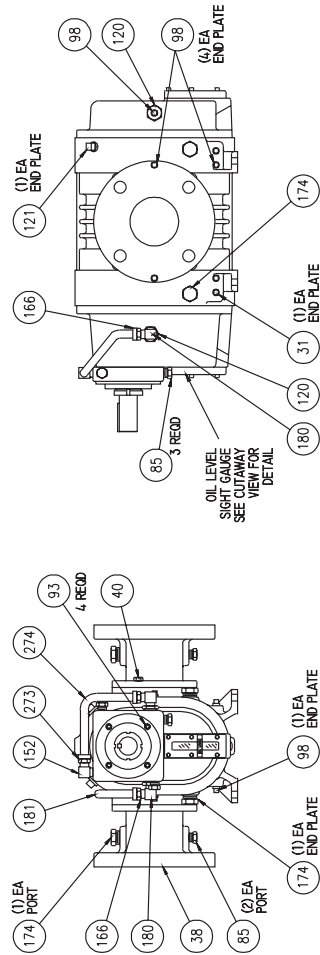

HORIZONTAL FLOW - SLINGER SEAL

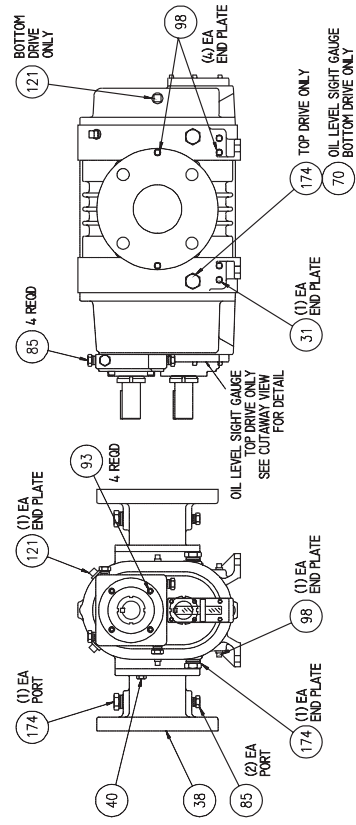

ASSEMBLY PRINTS FOR KMBD-540 AND KMBD-570 CUTAWAY VIEW

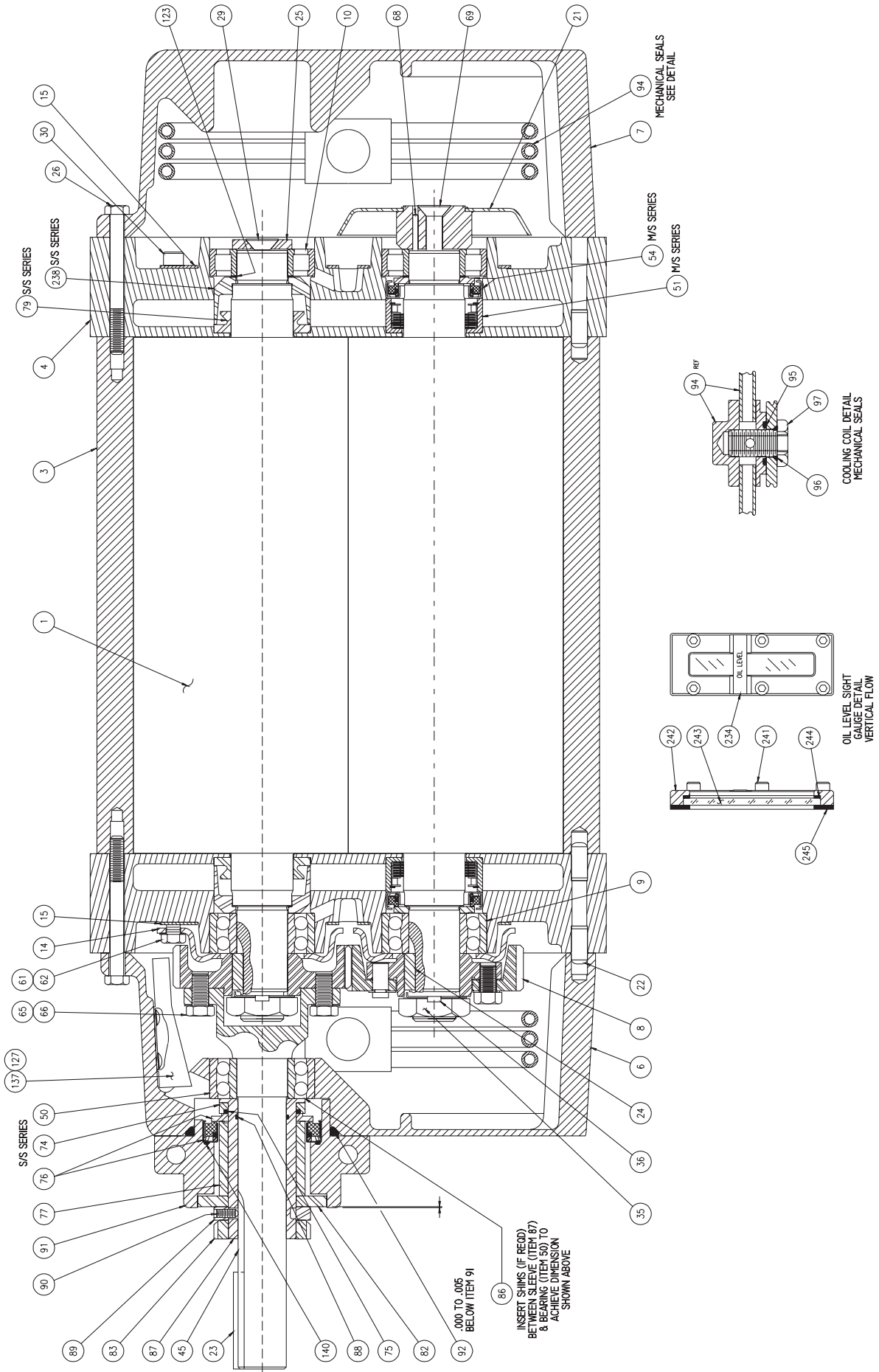

ASSEMBLY PRINTS FOR KMBD-540 AND KMBD-570
SIDE AND END VIEWS

VERTICAL FLOW - MECHANICAL SEAL

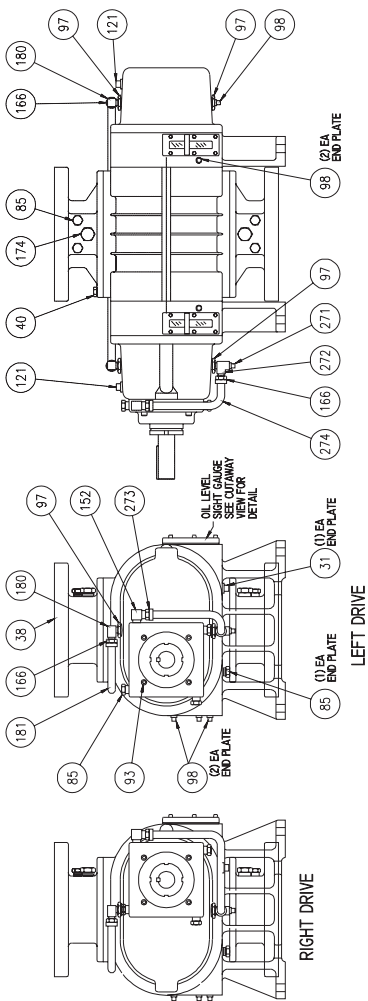

VERTICAL FLOW - SLINGER SEAL

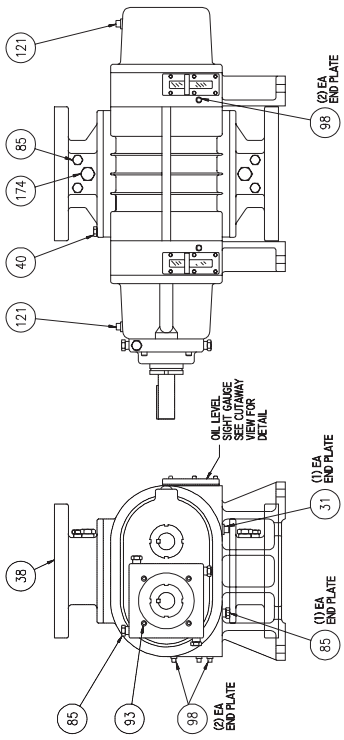

HORIZONTAL FLOW - MECHANICAL SEAL

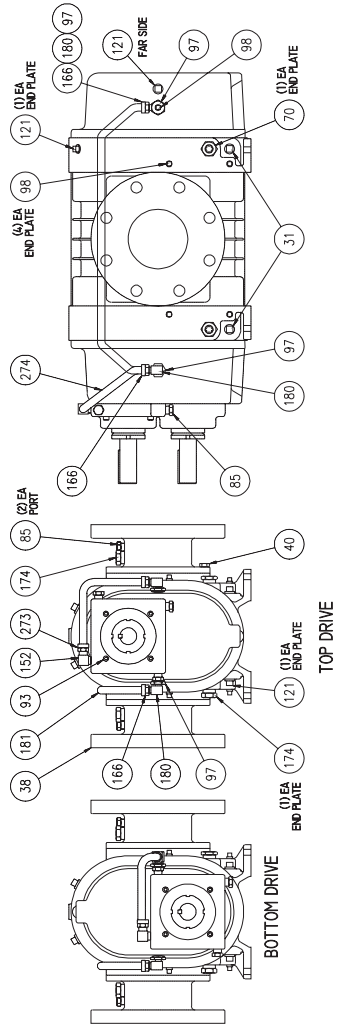

HORIZONTAL FLOW - SLINGER SEAL

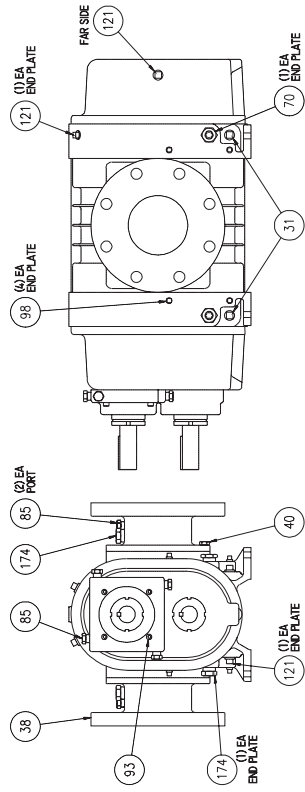

ASSEMBLY PRINTS FOR KMBD-850, 1600, 2000, AND 2700
CUTAWAY VIEW

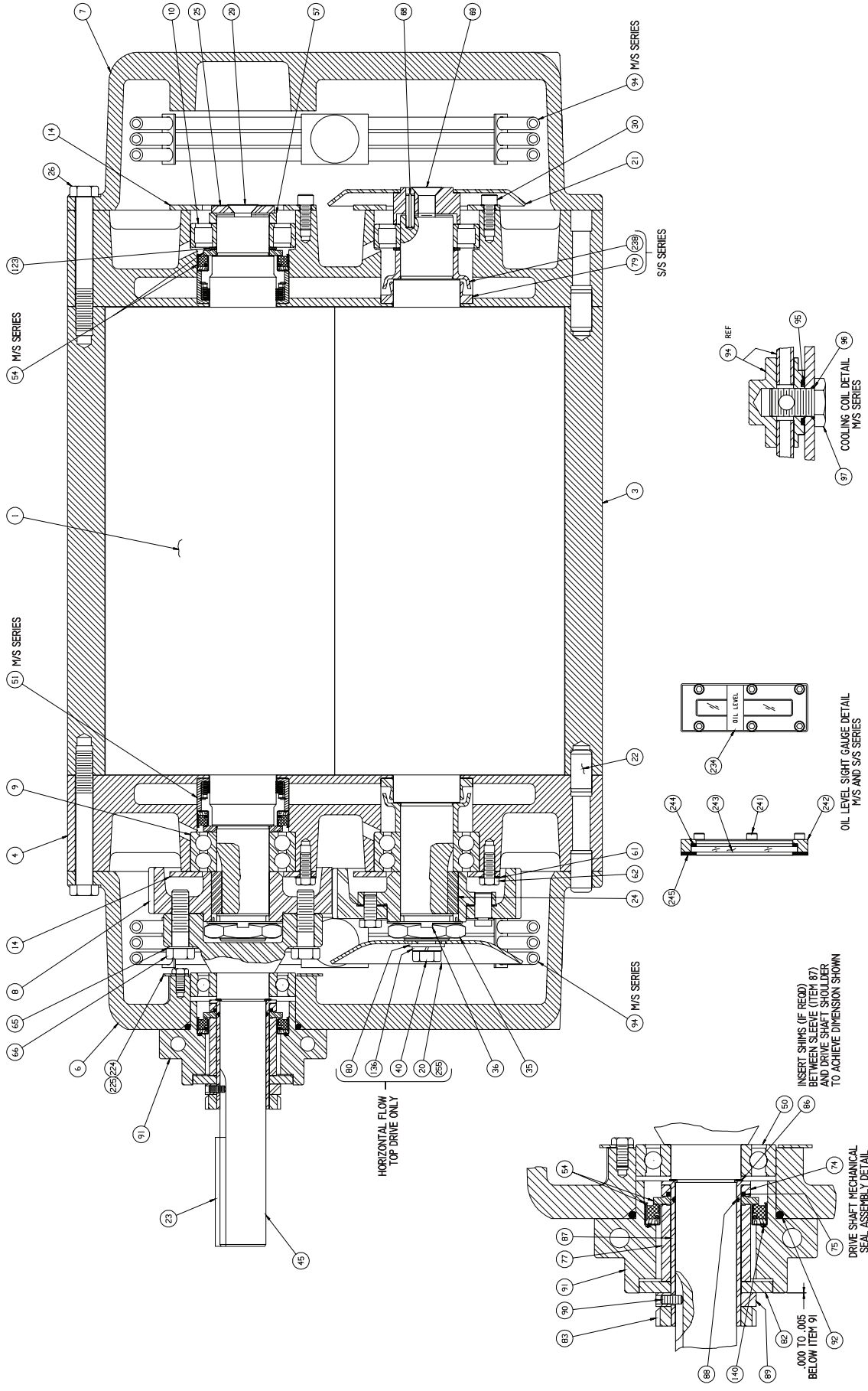

ASSEMBLY PRINTS FOR KMBD-850, 1600, 2000, AND 2700
SIDE AND END VIEWS

VERTICAL FLOW - MECHANICAL SEAL

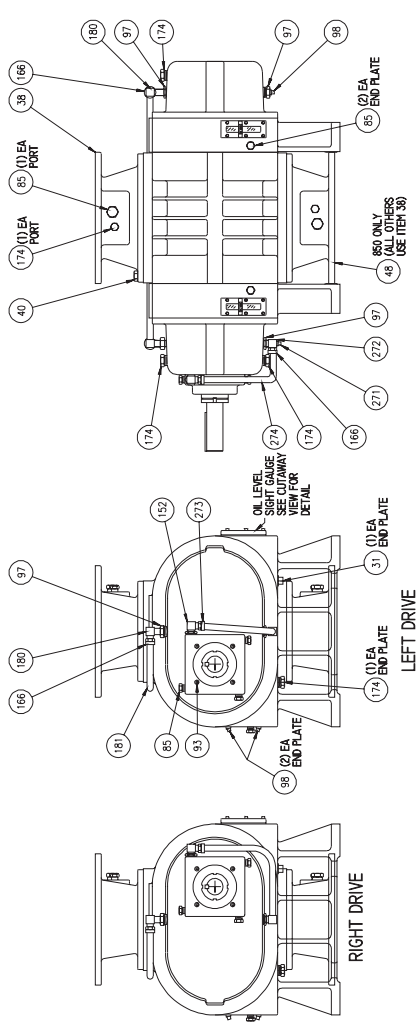

VERTICAL FLOW - SLINGER SEAL

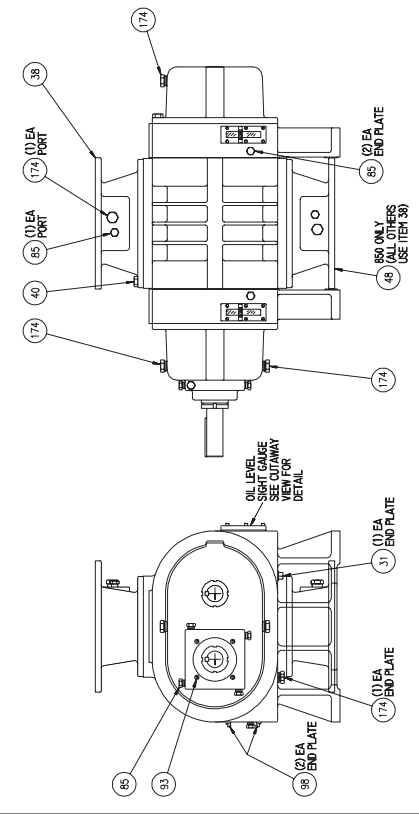

HORIZONTAL FLOW - MECHANICAL SEAL

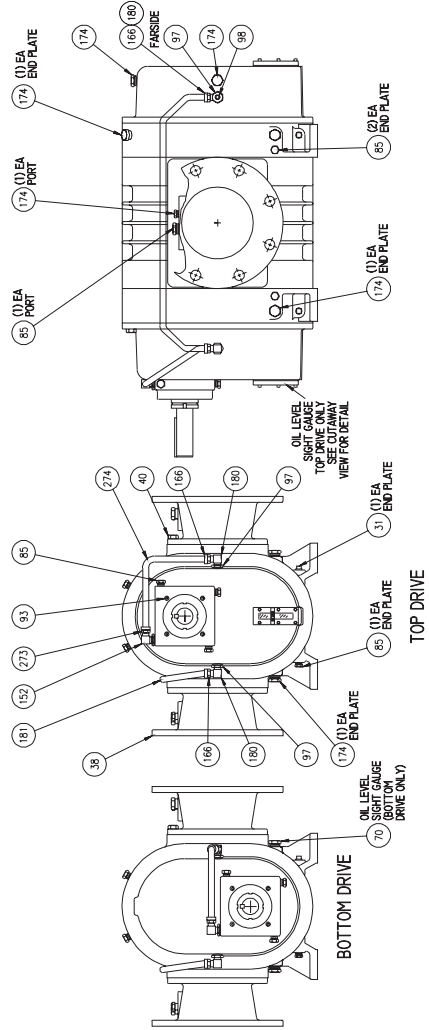

HORIZONTAL FLOW - SLINGER SEAL

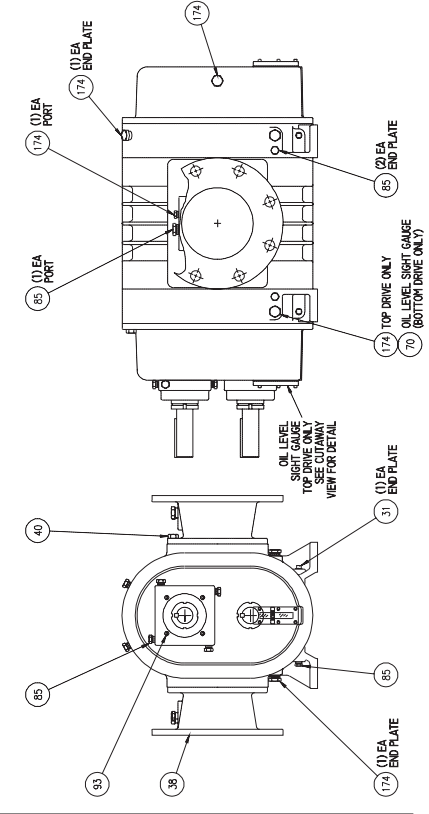

**KMBD-240 AND KMBD-400
SEAL PRESSING TOOL
T32018-1**

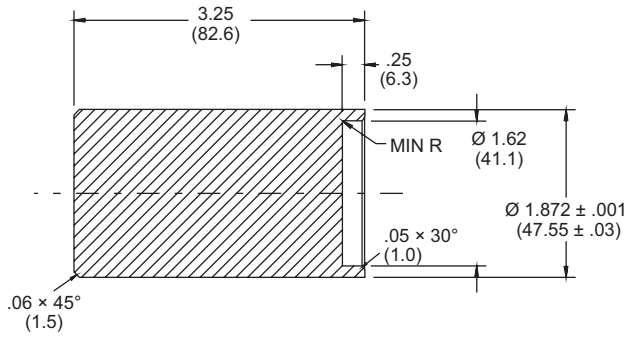

MATL P/N: CR1018R0-0200 × 3.50 (88.9) LG
MATL: COLD ROLLED 1018, 2.00 (50) OD × 3.50 (90) LONG

TOLERANCES

ENGLISH	METRIC
.XX = ± .01	.XX = ± .03
.XXX = ± .005	.XXX = ± .05
ANGULAR = ± .005	ANGULAR = °

NOTE:
DIMENSIONS SHOWN IN INCHES
DIMENSIONS IN () ARE IN UNITS OF MILLIMETERS
TOOLS T32018-1 & T32018-2 ARE USED TO INSTALL
MECHANICAL SEAL, LABRYINTH SEAL AND LIP SEAL
USED ON MODELS KMBD-240 AND 400 ROTOR SHAFTS.

**KMBD-240 AND KMBD-400
SEAL PRESSING TOOL
T32018-2**

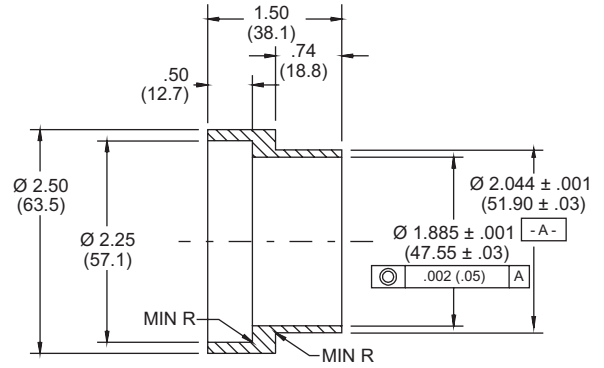

MATL P/N: CR1026T0-250050 × 1.75 (44.5) LG
MATL: COLD ROLLED 1026 TUBE, 2.50 (65)
OD × .50 (15) WALL × 1.75 (45) LONG

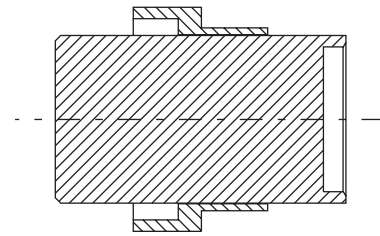

TOOL ASSEMBLY FOR END PLATE LAB SEAL, END PLATE LIP SEAL AND END PLATE MECHANICAL SEAL INSTALLATION

**KMBD-540 AND KMBD-720
MECHANICAL SEAL TOOL
T11549**

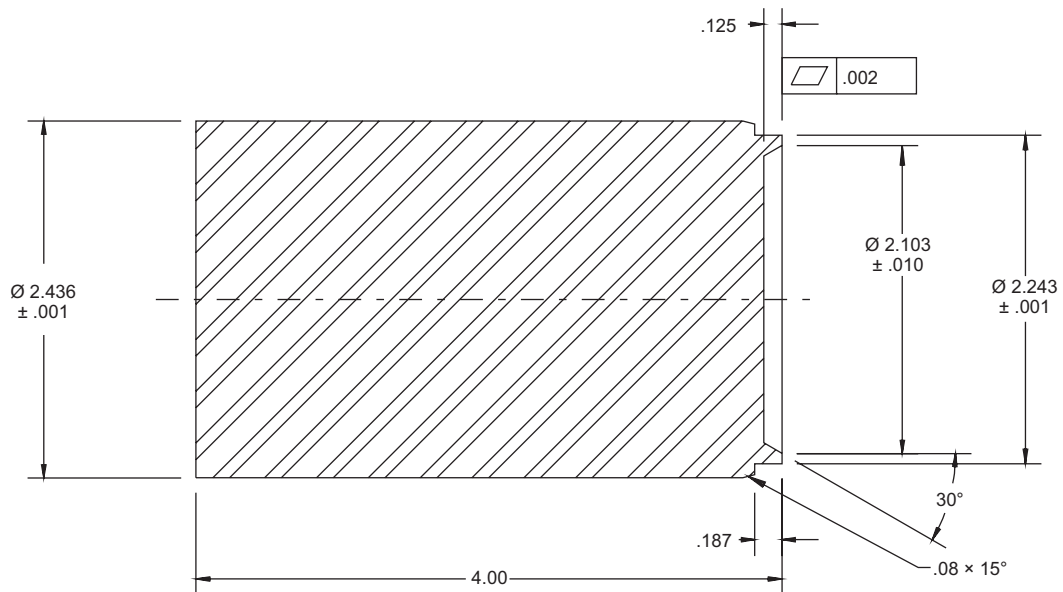

MATL P/N: CR1215R0-0250 × 4.25 (88.9) LG
MATL: COLD ROLLED STEEL BAR, Ø 2.50 (63.5) OD × 4.25 (107.95) LG

TOLERANCES

ENGLISH
.XX = ± .01
.XXX = ± .005
CHAMFERS = ± 2°

**KMBD-850, 1200, 1600, 2000, 2700
SEAL PRESSING TOOL
T11449-1**

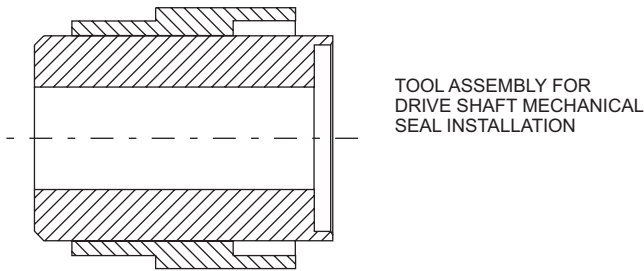
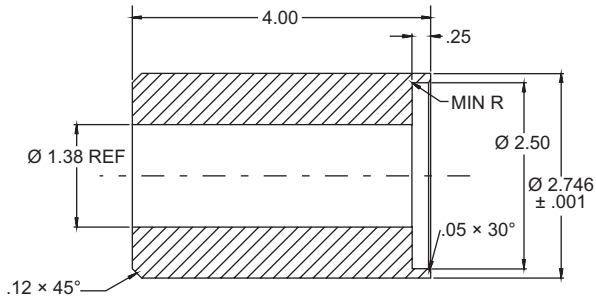

TOOL ASSEMBLY FOR
DRIVE SHAFT MECHANICAL
SEAL INSTALLATION

MATL P/N: CR1026T0-287075 x 4.25 LG
MATL: COLD ROLLED 1026 TUBE, 2.875 OD x 4.25 LONG

TOLERANCES

.XX = ± .01
.XXX = ± .005
CHAMFERS = ± 2°

**KMBD-850, 1200, 1600, 2000, 2700
SEAL PRESSING TOOL
T11449-2**

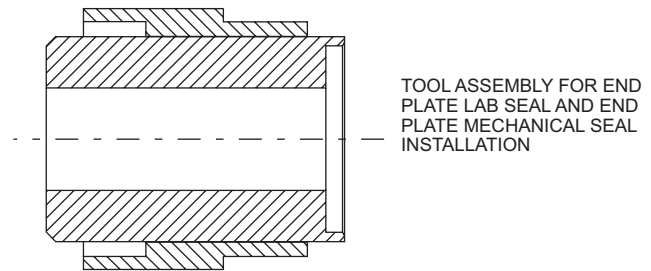
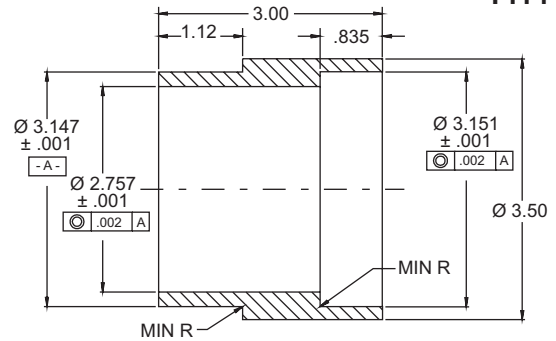

TOOL ASSEMBLY FOR END
PLATE LAB SEAL AND END
PLATE MECHANICAL SEAL
INSTALLATION

MATL P/N: CR1026T0-350050 x 3.25 LG
MATL: COLD ROLLED 1026 TUBE, 3.50 OD x .50 WALL x 3.25 LONG

NOTE:

TOOLS T11449-1 & T11449-2 ARE USED TO INSTALL MECHANICAL SEAL AND LABRYINTH SEAL USED ON MODELS KMBD-850, 1200, 1600, 2000 AND 2700 ROTOR SHAFTS. MECHANICAL SEAL USED ON MODELS KMBD-850, 1200, 1600, 2000 AND 2700 DRIVE SHAFTS AND MECHANICAL SEAL USED ON MODELS KMBD-540 AND 720 VACUUM BOOSTER DRIVE SHAFT.

**KMBD-540 AND KMBD-720
DRIVE SHAFT SEAL ASSEMBLY FIXTURE
T22179**

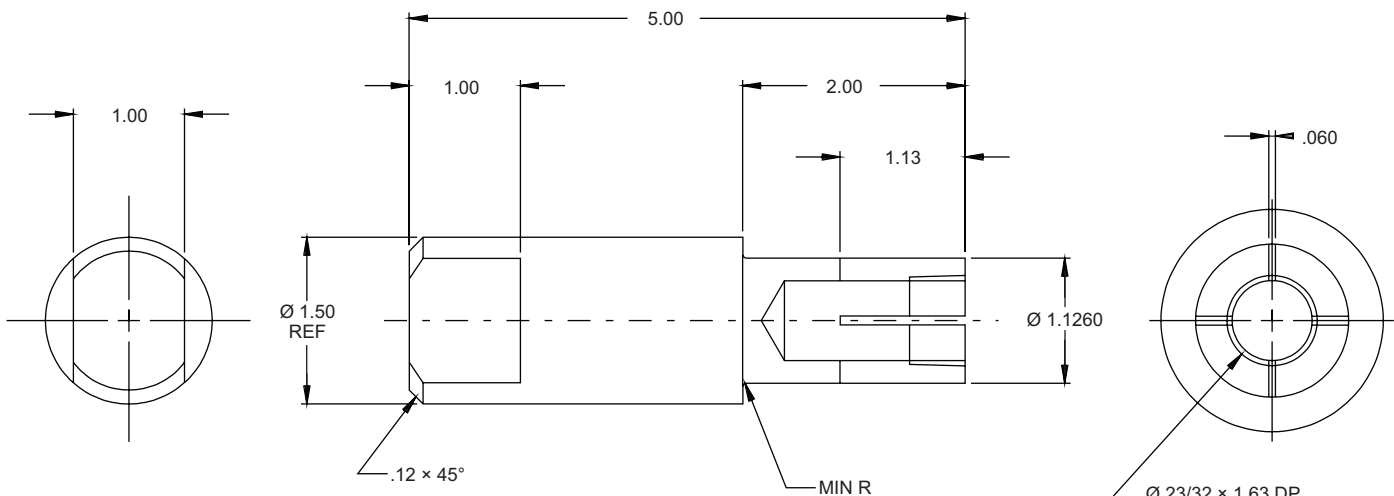

MATL P/N: CR1215R0-0150 x 5.25 (133.35) LG
MATL: COLD ROLLED STEEL BAR, Ø 1.50 (38.10) OD x 5.25 (133.35) LG

NOTES:

DIMENSIONS SHOWN IN INCHES
DIMENSIONS IN () ARE IN UNITS OF MILLIMETERS

FURNISH ONE M-D P/N 90094-050
1/2 NPT SOCKET HEAD PIPE PLUG

TOLERANCES

.XX = ± .01
.XXX = ± .005
.XXXX = ± .0005
CHAMFERS = ± 2°

**KMBD-850, 1200, 1600, 2000, 2700
DRIVE SHAFT SEAL
ASSEMBLY FIXTURE
T22180**

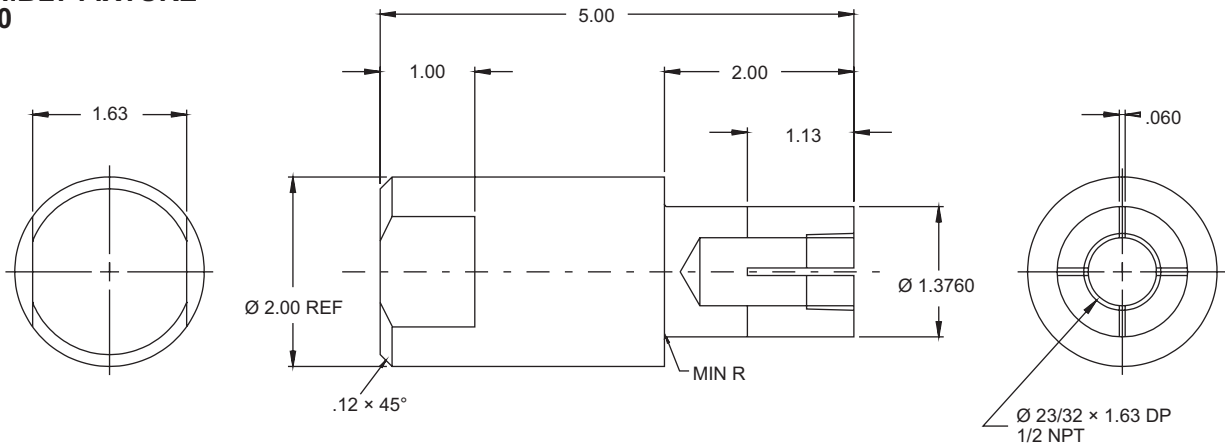

MATL P/N: CR1215R0-0200 x 5.25 LG
MATL: COLD ROLLED STEEL BAR, Ø 2.00 OD x 5.25 LG

NOTE:
FURNISH ONE (1) M-D P/N 90094-050
1/2 NPT SOCKET HEAD PIPE PLUG

TOLERANCES
.XX = ± .01
.XXX = ± .005
.XXXX = ± .0005
CHAMFERS = ± 2°

**KMBD-240 AND KMBD-400
SEAL INSTALLATION TOOLS
T27563-1**

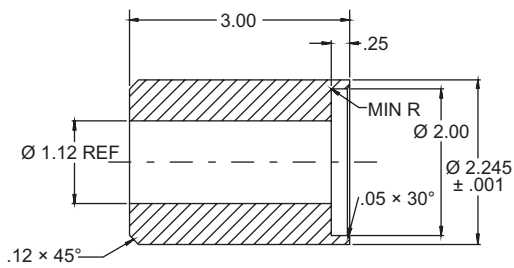

MATL P/N: CR1026T0-237062 x 3.25 LG
MATL: COLD ROLLED 1026 TUBE,
2 3/8 OD x 5/8 WALL x 3 1/4 LG

NOTE:
TOOLS T27563-1 & T27563-2 ARE USED TO INSTALL MECHANICAL SEAL USED ON MODELS KMBD-240 AND KMBD-400 VACUUM BOOSTER DRIVE SHAFT.

**KMBD-240 AND KMBD-400
SEAL INSTALLATION TOOLS
T27563-2**

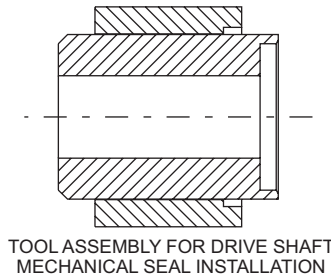

TOLERANCES
.XX = ± .01 .XXX = ± .005
ANGULAR = ± 2° CHAMFERS = ± 2°

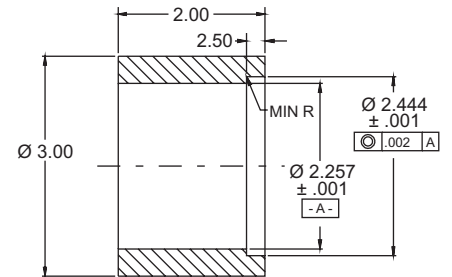

MATL P/N: CR1026T0-300050 x 2.25 LG
MATL: COLD ROLLED 1026 TUBE,
3 OD x 1/2 WALL x 2 1/4 LONG

**KMBD-240 AND KMBD-400
GEAR AND EP TOOL
T29603**

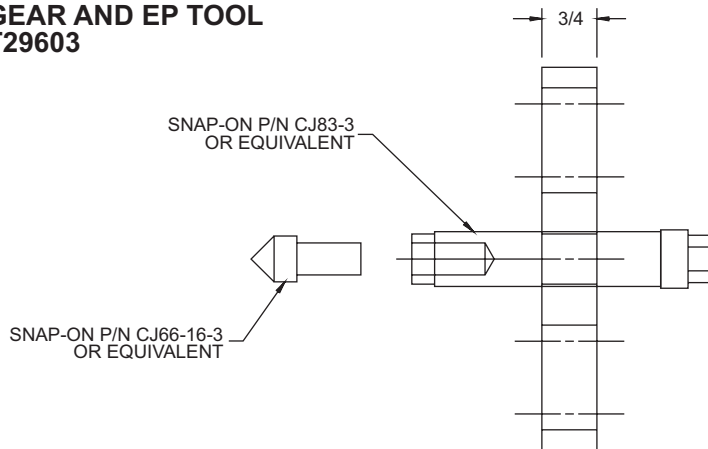

MATL P/N: CR1018B0-200075 x 5.50 LG
MATL: COLD ROLLED 1018 BAR, 2 3/4 x 5 1/2 LONG

TOLERANCES
FRACTIONAL = ± .0005
CHAMFERS = ± 2°

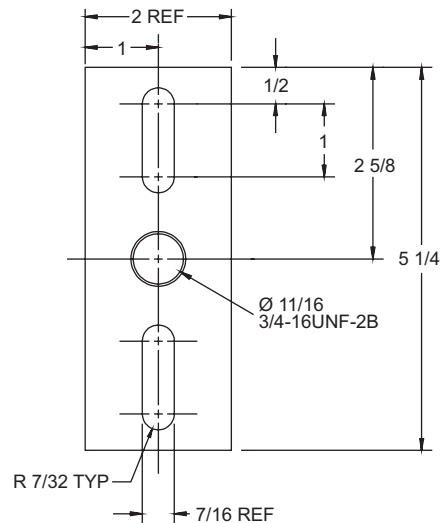

WARRANTY – VACUUM PRODUCTS

Subject to the terms and conditions hereinafter set forth and set forth in General Terms of Sale, Tuthill Vacuum & Blower Systems (the seller) warrants products and parts of its manufacture, when shipped, and its work (including installation and start-up) when performed, will be of good quality and will be free from defects in material and workmanship. This warranty applies only to Seller's equipment, under use and service in accordance with seller's written instructions, recommendations and ratings for installation, operating, maintenance and service of products, for a period as stated in the table below. Because of varying conditions of installation and operation, all guarantees of performance are subject to plus or minus 5% variation. (Non-standard materials are subject to a plus or minus 10% variation).

PRODUCT TYPE	WARRANTY DURATION
New	15 months after date of shipment or 12 months after initial startup date, whichever occurs first
Repair	6 months after date of shipment or remaining warranty period, whichever is greater
Remanufactured	9 months after date of shipment or 6 months after initial startup date, whichever occurs first

THIS WARRANTY EXTENDS ONLY TO BUYER AND/OR ORIGINAL END USER, AND IN NO EVENT SHALL THE SELLER BE LIABLE FOR PROPERTY DAMAGE SUSTAINED BY A PERSON DESIGNATED BY THE LAW OF ANY JURISDICTION AS A THIRD PARTY BENEFICIARY OF THIS WARRANTY OR ANY OTHER WARRANTY HELD TO SURVIVE SELLER'S DISCLAIMER.

All accessories furnished by Seller but manufactured by others bear only that manufacturer's standard warranty.

All claims for defective products, parts, or work under this warranty must be made in writing immediately upon discovery and, in any event within one (1) year from date of shipment of the applicable item and all claims for defective work must be made in writing immediately upon discovery and in any event within one (1) year from date of completion thereof by Seller. Unless done with prior written consent of Seller, any repairs, alterations or disassembly of Seller's equipment shall void warranty. Installation and transportation costs are not included and defective items must be held for Seller's inspection and returned to Seller's Ex-works point upon request.

THERE ARE NO WARRANTIES, EXPRESSED, IMPLIED OR STATUTORY WHICH EXTEND BEYOND THE DESCRIPTION ON THE FACE HEREOF, INCLUDING WITHOUT LIMITATION, THE IMPLIED WARRANTIES OF MERCHANTABILITY AND FITNESS OF PURPOSE.

After Buyer's submission of a claim as provided above and its approval, Seller shall at its option either repair or replace its product, part, or work at the original Ex-works point of shipment, or refund an equitable portion of the purchase price.

The products and parts sold hereunder are not warranted for operation with erosive or corrosive material or those which may lead to build up of material within the product supplied, nor those which are incompatible with the materials of construction. The Buyer shall have no claim whatsoever and no product or part shall be deemed to be defective by reason of failure to resist erosive or corrosive action nor for problems resulting from build-up of material within the unit nor for problems due to incompatibility with the materials of construction.

Any improper use, operation beyond capacity, substitution of parts not approved by Seller, or any alteration or repair by others in such manner as in Seller's judgment affects the product materially and adversely shall void this warranty.

No employee or representative of Seller other than an Officer of the Company is authorized to change this warranty in any way or grant any other warranty. Any such change by an Officer of the Company must be in writing.

The foregoing is Seller's only obligation and Buyer's only remedy for breach of warranty, and except for gross negligence, willful misconduct and remedies permitted under the General Terms of Sale in the sections on CONTRACT PERFORMANCE, INSPECTION AND ACCEPTANCE and the PATENTS Clause hereof, the foregoing is BUYER'S ONLY REMEDY HEREUNDER BY WAY OF BREACH OF CONTRACT, TORT OR OTHERWISE, WITHOUT REGARD TO WHETHER ANY DEFECT WAS DISCOVERED OR LATENT AT THE TIME OF DELIVERY OF THE PRODUCT OR WORK. In no event shall Buyer be entitled to incidental or consequential damages. Any action for breach of this agreement must commence within one (1) year after the cause of action has occurred.

December, 2002

OPERATING DATA

It is to the user's advantage to have the requested data filled in below and available in the event a problem should develop in the blower or the system. This information is also helpful when ordering spare parts.

Model No. _____ V-Belt Size: _____ Length: _____
Serial No. _____ Type of Lubrication: _____
Startup Date _____
Pump RPM _____ Operating Vacuum _____
Pump Sheave Diameter: _____ Any other special accessories supplied or in use:
Motor Sheave Diameter: _____
Motor RPM _____ HP _____

NOTES: _____

IMPORTANT

All mechanical vacuum boosters manufactured by Tuthill Vacuum & Blower Systems are date coded at time of shipment. In order to assure you of the full benefits of the product warranty, please complete, tear out and return the product registration card below, or you can visit our product registration web page at:

<http://www.tuthillvacuumblower.com/index.cfm/contact-us/product-registration/>

IMPORTANT				
All KINNEY® vacuum pumps manufactured by Tuthill Vacuum & Blower Systems are date coded at time of shipment. In order to assure you of the full benefits of the product warranty, please complete, tear out and return this product registration card.				
Company _____				
Location _____				
	City	State/Province	ZIP/Postal Code	Country
Telephone :	() _____			
E-mail:	_____			
Model:	_____			
Serial Number:	_____			
Date of Purchase:	_____			
Date of Startup:	_____			
PLEASE CHECK ONE				
	Vacuum Furnace		<input type="checkbox"/>	
	Vacuum Coating		<input type="checkbox"/>	
	Pharmaceutical		<input type="checkbox"/>	<input type="checkbox"/>
	Semiconductor/Electronics		<input type="checkbox"/>	
	Food/Meat Packing		<input type="checkbox"/>	
	Gas/Petrochemical		<input type="checkbox"/>	
	Other	_____		



NO POSTAGE
NECESSARY
IF MAILED
IN THE
UNITED STATES

BUSINESS REPLY MAIL

FIRST-CLASS MAIL PERMIT NO. 2912 SPRINGFIELD MO

POSTAGE WILL BE PAID BY ADDRESSEE

ATTN. CUSTOMER SERVICE – VACUUM PRODUCTS
TUTHILL VACUUM & BLOWER SYSTEMS
PO BOX 2877
SPRINGFIELD MO 65890-2150

