

**STOKES<sup>®</sup>**  
**VACUUM** Inc.  
EST. 1895

## VANE PUMP INSTRUCTIONS

### ROTARY VANE PUMP

MODEL  017 (37 CFM)  
 023 (55 CFM)

SPECIAL SERVICE

SERIAL NO. \_\_\_\_\_

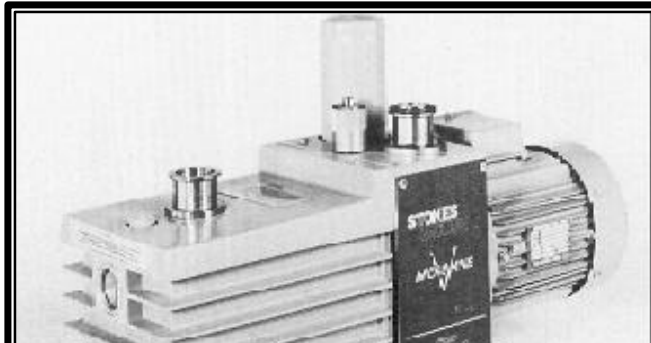

FOR SALES AND SERVICE PLEASE CALL:

**PTB SALES** T :: 866.332.0500  
F :: 626.334.2151  
[www.ptbsales.com](http://www.ptbsales.com)

DATE SERVICED: \_\_\_\_\_

**VIEW OUR INVENTORY**



Copyright © 2000  
All Rights Reserved  
Revision 1.0  
8/00



THANK YOU FOR YOUR PURCHASE OF A STOKES ROTARY VANE PUMP. WHEN CALLING WITH QUESTIONS OR PARTS ORDERS PLEASE CHECK THE NAMEPLATE OF YOUR PUMP AND HAVE THE MODEL NUMBER, LOT NUMBER AND/OR SERIAL NUMBER. ALSO PLEASE SPECIFY IF YOUR PUMP IS BEING USED FOR SPECIAL SERVICE PUMPING.

**STANDARD SERVICE VANE PUMPS**

MODEL: 009-2 (11 CFM)  
013-2 (20 CFM)  
017-2 (37 CFM)  
023-2 (55 CFM)

**STANDARD SERVICE VANE PUMPS WITH REED TYPE EXHAUST VALVE**

MODEL: 017-3 (37 CFM)  
017-4 (37 CFM)  
023-4 (55 CFM)  
023-5 (55 CFM)

**SPECIAL SERVICE VANE PUMPS**

MODEL: 009-241 (11 CFM)  
013-241 (20 CFM)  
017-241 (37 CFM)  
023-241 (55 CFM)

**SPECIAL SERVICE VANE PUMP WITH REED TYPE EXHAUST VALVE**

MODEL: 017-441 (37 CFM)  
017-444 (37 CFM)  
023-441 (55 CFM)  
023-445 (55 CFM)

# **NOTE:**

***“THE INFORMATION HEREIN SHALL BE TREATED IN THE STRICTEST CONFIDENCE, AND SHALL NOT BE DISCLOSED TO ANY THIRD PARTY WITHOUT THE PRIOR WRITTEN PERMISSION OF STOKES VACUUM INC.***

***THE INFORMATION SHALL BE USED SOLELY FOR THE PURPOSE FOR WHICH IT HAS BEEN SUPPLIED AND FOR NO OTHER PURPOSE WHATSOEVER.”***

***STOKES VACUUM INC., PHILADELPHIA, PA.***

# WARNING

IF THIS PUMP HAS BEEN USED TO PUMP TOXIC, CORROSIVE, EXPLOSIVE, FLAMMABLE OR OTHER TYPES OF HAZARDOUS PROCESS GASES AND MATERIALS, BEFORE SERVICING, PRECAUTIONS MUST BE TAKEN TO PREVENT SERIOUS PERSONAL INJURY TO PERSONNEL.

BEFORE HANDLING OR ATTEMPTING TO SERVICE, SERVICE PERSONNEL MUST CONSULT THE USER TO DETERMINE THE TYPES OF PROCESS MATERIAL PUMPED AND THE NAZARDS INVOLVED. THE USER MUST BE REQUESTED TO RENDER THE PROCESS MATERIAL HARMLESS OR INSTRUCT THE SERVICE PERSONNEL IN SUCH PROCESS AND THE PRECAUTIONS TO BE TAKEN.

PROTECT CLOTHING AND RESPIRATORY APPARATUS MUST BE USED. SERVICE MUST BE PERFORMED IN A PROPERLY VENTILATED AND PROTECTED AREA.

EPA, OSHA, OTHER STATUATORY REGULATIONS MUST BE FOLLOWED IN HANDLING THE PUMP AND DISPOSING OF THE PROCESS MATERIALS AND CONTAMINATED PUMP FLUID.

ALL PARTS AND OPENINGS IN THE PUMP SHOULD BE SEALED FOR HANDLING AND WHEN TRANSPORTING.

# HAZARDS

DO NOT OBSTRUCT THE EXHAUST. EXHAUST PRESSURE SHOULD NOT EXCEED 2 PSIG. EXCESSIVE PRESSURE CAN DAMAGE PUMP OR RESULT IN PERSONAL INJURY.

CONTINUOUS HIGH INLET PRESSURE, ABOVE 5 TORR, WILL CAUSE INCREASED SMOKE OR MIST. THIS FINELY ATOMIZED OIL VAPOR SHOULD BE VENTED TO THE OUTDOORS IF PUMP IS TO BE OPERATED FOR PROLONGED PERIODS UNDER THESE CONDITIONS TO PREVENT LUNG IRRITATION.

FOR THOSE PUMPS PROVIDED WITH A FILTER, DO NOT REMOVE OIL FILTER WHEN PUMP IS RUNNING. WHEN TOXIC, FLAMMABLE, EXPLOSIVE, OR OTHER HAZARDOUS SUBSTANCES ARE COLLECTED IN THE FILTER PRECAUTIONS APPROPRIATE TO SUBSTANCE BEING COLLECTED MUST BE EXERCISED IN SERVICING TO PREVENT SERIOUS PERSONAL INJURY.

SPECIAL PRECAUTIONS MUST BE OBSERVED WHEN PUMPING TOXIC, OXYDIZING OR EXPLOSIVE GASES.

(SEE SECTION 3.1.5) REF. VANE PUMP MANUAL AND SUPPLEMENTARY DATA PUMPING HAZARDOUS GASES

## **SAFETY PRECAUTIONS**

WHEN OPERATING AND SERVICING THIS EQUIPMENT IT IS IMPORTANT THAT ALL PERSONNEL OBSERVE SAFETY PRECAUTIONS TO MINIMIZE THE CHANCES OF INJURY. THE FOLLOW CONSIDERATIONS SHOULD PARTICULARLY BE NOTED.

DO NOT REACH INTO ANY OPENING IN THE PUMP WHILE IT IS OPERATING, OR WHILE SUBJECT TO ACCIDENTAL STARTING.

PUMP CASING AND ASSICIATED PIPING AND ACCESSORIES MAY BECOME HOT ENOUGH TO CAUSE SKIN BURNS ON CONTACT.

DISCONNECT POWER BEFORE DOING ANY WORK ON PUMP. WHEN PUMPING HAZARDOUS OR TOXIC GASES, OR WHEN DRAINING OIL OR SERVICING THE PUMP, CARE MUST BE TAKEN TO PREVENT SKIN CONTACT WITH FLUID OR BREATHING THE GASES.

**STOKES CARE . . . JUST THE RIGHT KIND . . . AT THE RIGHT TIME**

**INSIST ON STOKES GENUINE PARTS AND LUBRICANTS**



**QUALITY PARTS REPAIR FIELD SERVICE WE CARE**



TO YOU, OUR VALUABLE CUSTOMER, YOUR COMPLETE SATISFACTION IS OUR GOAL. USE STOKES GENUINE OEM PARTS, PREVENTIVE MAINTENANCE AND OIL REQUIREMENTS TO ASSURE YOUR SATISFACTION AND WARRANTY.

**CONTACT STOKES FOR ALL YOUR SERVICE NEEDS**

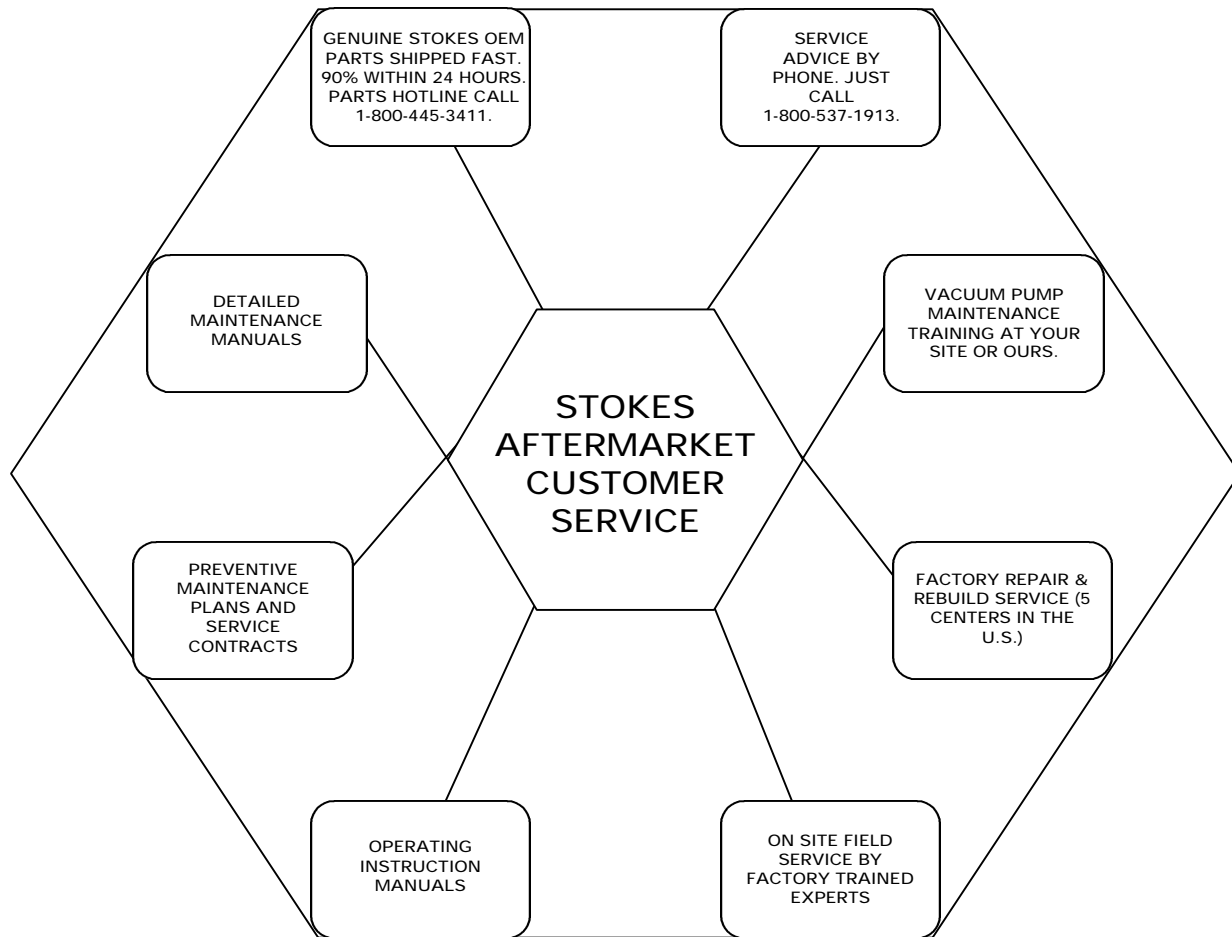

**USE YOUR INSTRUCTION MANUAL.** YOU WILL FIND A PREVENTIVE MAINTENANCE CHECKLIST, THE TYPE OF LUBRICANTS TO BE USED, A RECOMMENDED SPARE PARTS LIST, ACCESSORIES FOR OUR VACUUM PUMPS AND BLOWER AND OTHER HELPFUL INFORMATION.

STOKES VACUUM INC. HAS BEEN A WORLD RENOWNED MANUFACTURER OF HIGH QUALITY VACUUM EQUIPMENT FOR OVER 100 YEARS.

STOKES VACUUM INC., 5500 TABOR ROAD, PHILADELPHIA, PA. 19120 USA 215-831-5400 FAX 215-831-5420 <http://www.stokesvacuum.com>

## CONTENTS

<b>1.0</b>	<b>DESCRIPTION.....</b>	<b>1-1</b>
1.1	INTRODUCTION.....	1-1
1.2	FEATURES OF STOKES VANE PUMPS.....	1-1
<b>2.0</b>	<b>INSTALLATION.....</b>	<b>2-1</b>
2.1	GENERAL.....	2-1
2.2	LOCATION.....	2-1
2.3	CONNECTING TO THE SYSTEM.....	2-1
2.4	ELECTRICAL.....	2-1
2.5	LUBRICATING OIL.....	2-1
<b>3.0</b>	<b>OPERATION.....</b>	<b>3-1</b>
3.1	GENERAL.....	3-1
3.2	START-UP-RUNNING.....	3-1
3.3	GAS BALLAST OPERATION (STANDARD).....	3-1
3.4	GAS BALLAST OPERATION (OPTIONAL).....	3-2
3.5	SHUT-DOWN PROCEDURES.....	3-2
<b>4.0</b>	<b>MAINTENANCE.....</b>	<b>4-1</b>
4.1	PREVENTIVE MAINTENANCE.....	4-1
<b>5.0</b>	<b>SERVICING.....</b>	<b>5-1</b>
5.1	GENERAL.....	5-1
5.2	MINOR SERVICING.....	5-1
5.3	MAJOR SERVICING.....	5-2
5.4	MODULE REPLACEMENT.....	5-7
5.5	TROUBLESHOOTING GUIDE.....	5-9
<b>6.0</b>	<b>VACUUM SYSTEM INSTALLATION.....</b>	<b>6-1</b>
<b>7.0</b>	<b>VACUUM SYSTEM ACCESSORIES.....</b>	<b>7-1</b>
7.1	INLET FILTERS.....	7-1
7.2	INLET TRAPS.....	7-1
7.3	OILS.....	7-1
7.4	EXHAUST OIL MIST ELIMINATOR:.....	7-1
7.5	OIL FILTERING SYSTEMS:.....	7-1
7.6	ISO - VACUUM FITTINGS.....	7-2
7.7	SPECIAL OIL LEVEL INDICATOR.....	7-2
7.8	HIGH VACUUM BLOWERS.....	7-2

## 1.0 DESCRIPTION

### 1.1 INTRODUCTION

This manual provides data and information, which should be helpful to you in operating and maintaining your pump. Installation information and general vacuum system design data are provided to help you realize the pumps fullest capability. If additional assistance is needed, contact Stokes Vacuum Inc.

### 1.2 FEATURES OF STOKES VANE PUMPS

#### 1.2.1 GENERAL

Stokes vane pumps are ruggedly built, highly efficient units with positive oil circulation, built-in filter (in some models), with full gas ballast and anti-suck back devices. Materials of construction were selected for chemical process service. Blank-off pressure is .5 microns or lower.

#### 1.2.2 MATERIALS OF CONSTRUCTION

The pumps, as constructed, are essentially chemical service pumps. Copper and copper-bearing materials have been avoided. Cast iron is used extensively and, with the exception of the aluminum oil reservoir, all metallic parts including the bushings are ferrous materials. All springs are stainless steel. With this construction, the potential for erosion due to galvanic action is drastically reduced. To resist the effects of abrasion, the shaft segments that run in the seals are hardened. All elastomeric parts in contact with the process gas are Viton. The vane plastic material was selected for its chemical resistance.

#### 1.2.3 OIL CIRCULATION PUMP

A positive displacement, shaft-driven, gear pump with relief valve assures a continuous flow of lubricating and sealing oil at all pump inlet pressures. On pump models with an integral oil filter, the oil pump also feeds oil to the filter.

Oil from the pump is fed to the filter by the oil circulation pump. Filtered oil is fed back to the pump assuring a continuous supply of clean oil for pump operation. A relief valve in the filter bypasses oil when the filter is plugged. Periodic inspection of the filter is recommended.

For exceptionally dirty applications, where the capacity of the integral filter is inadequate requiring frequent changes, an optional adapter and large capacity external oil filter can be supplied.

#### 1.2.4 GAS BALLAST VALVE

The gas ballast valve arrangement provides for full flow when open and a hermetic shut-off when closed. Construction is such that when open, air is admitted only through the valve inlet port. This is important for those systems that cannot tolerate air gas ballast. The inlet port is threaded to facilitate connection to a gas source. When using a pressurized gas source, pressure must be limited to one PSIG.

#### 1.2.5 GAS PURGE PORT

An auxiliary gas purge port is provided on the reservoir to facilitate connecting to a purge gas supply. In processes where a reaction with air may result in corrosive and/or explosive conditions, it has become common practice to use a non-reactive purge gas. When using the reservoir purge port, pressure should be limited to one PSIG. Where warranted and where conditions permit, inert gases are sometimes admitted to the suction intake, gas ballast and reservoir purge ports simultaneously.



### *1.2.6 ANTI-SUCKBACK*

When the pump is stopped the oil-feed port is closed off preventing oil from leaking back into the pumping module where it could make for hard starting and, in extreme cases, leak back into the vacuum system and break vacuum. It is good practice, however, to valve off the pump and break vacuum when the pump is stopped.

### *1.2.7 INLET AND OUTLET PORTS*

These ports are adapted for ISO type quick clamp fittings for ease of assembly. The inlet port is supplied with a screen to minimize the possibility of damage by particle ingestion.

### *1.2.8 MAINTENANCE - MODULAR CONSTRUCTION*

Stokes vane pumps have been designed for ease of maintenance. Assembly and disassembly can be accomplished with tools readily found in most shops. Minor and major repair kits are available. The minor repair kit provides parts that can be changed without pump disassembly. A combination of the minor and major kits provides parts for a major rebuild.

For those who do not want to rebuild, the pumping module may be easily removed and exchanged for a new or rebuilt unit. Stokes offers an attractive exchange program for pumping modules.

## **2.0 INSTALLATION**

### **2.1 GENERAL**

On receipt of pump, check for any damage that may have occurred during transit. Report any shipping damage or missing parts to carrier within 15 days and to Stokes promptly.

### **2.2 LOCATION**

The pump is provided with rubber mounts and need not be bolted down. The rubber mounts can be removed and the pump bolted in place, should this be required. Under those circumstances a level, flat, smooth mounting surface must be provided. It should be horizontally mounted and located to provide adequate cooling and ventilation for the motor and finned oil reservoir.

### **2.3 CONNECTING TO THE SYSTEM**

REMOVE AND DISCARD THE PROTECTIVE COVERS AND DESICCANT PACKETS FROM THE INLET AND EXHAUST PORTS.

Inlet and outlet connections are ISO-NW flanges. To minimize line losses, the pump should be connected as close as possible to the system. The connecting tubing should have an inside diameter at least as large as the inside diameter of the pump inlet fit-ting.

A centering ring with "O" ring and wire mesh filter are provided for the inlet line.

The pump outlet must be unobstructed to prevent build-up of pressure in the reservoir, which can be dangerous.

A flexible connection should be located in the pipe from the pump to the system.

Molecular Sieve Fore line traps and Coaxial Fore line traps are available for mounting at the inlet. (See Stokes Accessory catalog for additional information).

The exhaust line minimum I.D. should be the same as the I.D. of the exhaust port. Slope away from the pump to prevent condensable vapors from condensing and returning to the pump. To provide removal of oil mist from the exhaust an Oil Mist Separator can be fitted to the pump outlet. (See Stokes Accessory catalog for additional information).

### **2.4 ELECTRICAL**

The electrical motor power supply should match nameplate specifications. In making the motor connections insure that everything is grounded properly, and that fuses, and starters with motor overloads, are provided to protect the pump motor.

Connect the terminals as shown on the nameplate or in the terminal box. Unless otherwise stated, the motor is wired to operate at the lower nameplate voltage.

Pump rotation should be counter-clockwise when viewed from the motor end of the unit. Observe fan on end of motor. Jog pump after connecting to determine rotation. Change any two wires if not correct.

### **2.5 LUBRICATING OIL**

Standard pumps are shipped with a full charge of oil. It is necessary to add oil only if the level is below the oil level line on the oil sight glass. To add oil, remove the oil fill plug at the oil sight glass end of the reservoir and add sufficient oil to fill to the middle of the sight glass with pump in operation or, for those pumps with a filter, ¼" above middle of gauge with pump stopped.

### 3.0 OPERATION

#### 3.1 GENERAL

- 3.1.1 Always check to be sure that the pump oil is visible in sight glass. Insufficient oil will cause improper operation and possible damage to the pump. Normal level is determined when the pump is running blanked-off (at ultimate vacuum).
- 3.1.2 Use only Stokes approved mechanical pump oils for pump operation. Pumps are shipped with full charge of Stokes V-Lube "J" for standard service. See section 3.1.5 for use of special oils.
- 3.1.3 All pumps have wire mesh filters in the inlet port. All possible care should be taken to prevent any foreign particles from entering the pump inlet.
- 3.1.4 Minimum pump cold start-up temperature is 50°F (10°C).
- 3.1.5 Oxygen Service or Special Service

When pumping gas with an oxygen concentration of greater than 20%, or explosive or flammable gases, or process gases, which attack hydrocarbon oil, special inert fluids must be used to avoid explosions. Two such fluids are "Fomblin" Y06/6 and "Krytox" 1506.

**WARNING** DO NOT mix hydrocarbon oil with the special fluids used for oxygen service or special service, otherwise an explosion may result. Oxygen service or special service pumps may be identified by the numerals "41, 44 or 45" following the model number on the pump nameplate.

#### 3.2 START-UP-RUNNING

- 3.2.1 Gas Ballast Valve should be in closed position.
- 3.2.2 Energize pump with system shut-off valve, by customer, closed. The pump will emit a gurgling sound for a short time (depending on the volume being evacuated), but the sound will disappear as the pressure is reduced.
- 3.2.3 When starting the pump cold or after changing the oil, the pump may be run for ½ hour or more with open gas ballast to purge the oil of possible contaminants. (See Gas Ballast Operation).

#### 3.3 GAS BALLAST OPERATION (STANDARD)

- 3.3.1 During the compression cycle, gases (usually water vapor) may condense and mix with oil. This may cause a rise in the attainable blank-off-off pressure. Opening the gas ballast valve introduces ambient air to the compression cycle of the second stage preventing condensation and thus allowing condensibles to pass through the pump as vapor. After pumping appreciable quantities of condensable vapors, it is recommended that the pump be allowed to run with the gas ballast valve fully open ½ hour or more to purge the oil. During gas ballasting, increased oil mist discharge is normal. Greater attention should be given to maintaining proper oil level while operating under these conditions. One should not assume that gas ballasting eliminates the need for timely oil changes.

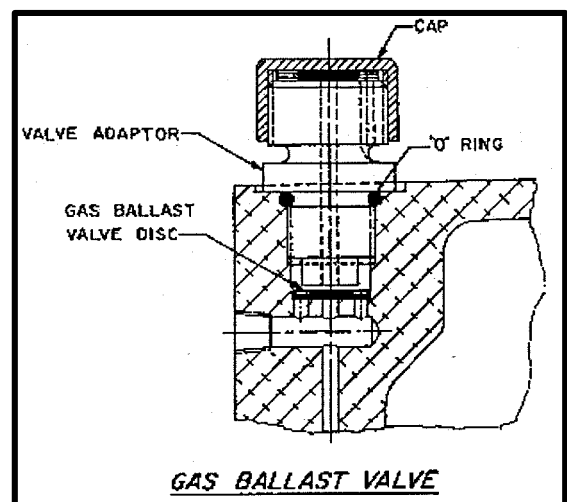

### 3.4 GAS BALLAST OPERATION (OPTIONAL)

*THIS GAS BALLAST IS OPTIONAL ON THE STANDARD UNIT BUT IS STANDARD ON SPECIAL SERVICE UNITS.*

- 3.4.1 During the compression cycle, gases (usually water vapor) may condense and mix with oil. This may cause a rise in the attainable blank-off-off pressure. Opening the gas ballast valve introduces ambient air, or other inert gas or nitrogen, when explosive or corrosive vapors are being pumped, to the compression cycle of the second stage preventing condensation and thus allowing condensable to pass through the pump as vapor. Where air is not compatible with the process gases, inert gas may be used for gas ballasting. After pumping appreciable quantities of condensable vapors, it is recommended that the pump be allowed to run with the gas ballast valve fully open ½ hour or more to purge the oil. During gas ballasting, increased oil mist discharge is normal. Greater attention should be given to maintaining proper oil level while operating under these conditions. One should not assume that gas ballasting eliminates the need for timely oil changes.

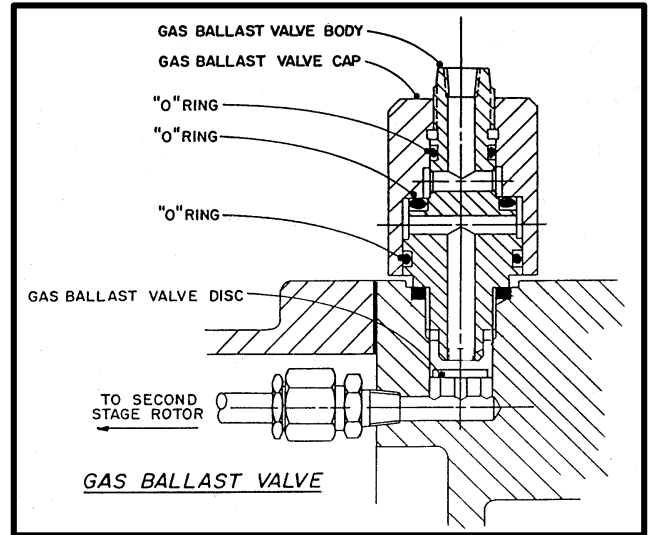

### 3.5 SHUT-DOWN PROCEDURES

- 3.5.1 Isolate the pump by closing the System Shut-off Valve.
- 3.5.2 Turn off the motor.
- 3.5.3 Stokes pumps are equipped with an anti-suck back device to prevent hydraulic loading. However, it is good practice to vent the pump during shutdown.
- 3.5.4 If the pump is not to be used for an extended period, (two weeks or longer, this will vary with applications), drain, with oil hot, and refill with fresh oil to help prevent corrosion due to contaminated oil. Gas ballast at start-up to degass oil.

## 4.0 MAINTENANCE

### 4.1 PREVENTIVE MAINTENANCE

4.1.1 The oil level in the reservoir should be checked daily, and should be at the middle of the sight glass when pump is operating.

4.1.2 The oil should be changed on the following schedule:

- a) When contaminated - Oil is dark or appears dirty, has "burned" odor.
- b) When the oil is cloudy (with condensate) which will not turn clear when the pump is run on gas ballast for two (2) hours.
- c) Unable to attain Low Pressure Bank-off.
- d) When the pump will not be run for an extended period (2 weeks or more).

4.1.3 Check condition of exhaust valves every 3 months when pump is operated continuously. Replace the valve if the sealing surface shows signs of wear. Clean out any dirt accumulation in the reservoir.

Precautions must be taken if the pump was used to pump hazardous gases or materials. See Warning Sheets at rear of manual.

*NOTE:* An oil change schedule ultimately depends upon the operating conditions of the pump. Frequent checks of the oil must be made and the oil changed as necessary. For corrosive or very dirty applications, a high capacity external oil filtration system is recommended. (See Stokes accessory catalog for additional information).

4.1.4 Oil Change - *Always while pump is hot.*

Isolate pump. Shut gas ballast valve, if open. Stop the pump and break vacuum. Open fill plug slightly. Place container under plug and remove drain plug to empty reservoir.

Should the oil removed be very dirty, the pump should be flushed with clean oil as follows:

- a) Disconnect vacuum line at inlet flange.
- b) Turn pump on and SLOWLY pour a complete change of fresh oil (equal to the reservoir capacity) through inlet. Be sure drain plug is installed.
- c) Run pump for 5 minutes.
- d) Stop pump and drain oil through drain plug.
- e) Re-connect vacuum line and replace drain plug.
- f) For pumps with filters, fill pump to ¼" over midpoint of sight glass with fresh oil with pump not running. Fill pumps without filters to midpoint of sight glass.

4.1.5 The inlet filter screen should be cleaned at each oil change or as experience dictates. To clean inlet screen:

- a) Disconnect vacuum line at inlet flange.
- b) Remove inlet screen and clean with a suitable solvent such as chlorethene.
- c) Replace inlet screen and "O" ring.

d) Connect vacuum line.

4.1.6 For pumps with filters on the pump, the oil filter should be changed at each oil change or as necessary.

To Change Filter:

a) Stop pump.

b) Unscrew oil filter.

c) Clean area under oil filter and inspect relief valve spring under filter for dirt. Clean the spring, if necessary, by removing the spring retainer and spring. Replace after cleaning.

d) Install new filter. Tighten  $\frac{1}{4}$  turn after gasket contact.

*NOTE:* This filter is selected to be compatible to the functioning of the pump. Use of a standard automotive filter may result in damage to the pump. Refer to Parts List for proper filter.

4.1.7 Lubricate motor every six (6) months with high quality Lithium Base #2 grease.

**5.0 SERVICING**

**5.1 GENERAL**

5.1.1 For servicing the pump beyond routine preventative maintenance, Stokes has available two levels of repair kits, as well as complete module replacement.

5.1.2 The first level repair kit contains those items which can be installed on the pump without major disassembly of the pump module. This includes such items as "O" rings, gaskets and exhaust valves and springs.

5.1.3 The second level kit consists of items which require extensive disassembly of the pump module to replace.

This would include such items as the vanes and their springs, oil seals and bushings.

5.1.4 Required tools:

MODEL	ALLEN KEYS	OPEN WRENCHES	SCREWDRIVER
017	4,5,6,8 MM	10, 17 MM, 7/16" 3/4", 7/8"	YES
023	4,5,6,8 MM	10, 17 MM, 7/16" 3/4", 7/8"	YES

**5.2 MINOR SERVICING**

**STOP PUMP AND DISCONNECT POWER TO THE PUMP BEFORE SERVICING**

**5.2.1 "O" ring - Fill Plug**

Remove fill plug, remove and replace "O" ring.

**5.2.2 "O" ring - Drain Plug**

Remove drain plug and drain oil into container. Remove and replace "O" ring.

**5.2.3 "O" ring - Gas Ballast Seal**

Remove gas ballast cap. Remove and replace "O" ring seal that is the middle "O" ring on the gas ballast body. Replace gas ballast cap.

**5.2.4 Gas Ballast Check Disc**

Remove gas ballast cap. Unscrew gas ballast assembly from support housing using the wrench flats on the body. Remove check disc from counter bore in support housing and replace with new disc. Replace gas ballast body and cap.

## STOKES VACUUM ROTARY VANE PUMP

### 5.2.5 Reservoir Gasket

Drain oil. Remove oil reservoir by removing the two side covers, then the four hex socket screws holding the reservoir to the support housing. Remove and replace gasket. Replace reservoir and side covers.

**WARNING:** Failure to replace side covers could result in personal injury from rotating machinery.

### 5.2.6 Exhaust Valves and Springs

**NOTE:** Reed Valve for Models 17 & 23 Vane pumps shown on 2nd Stage Stator.

To gain access to the exhaust valves and springs, the oil reservoir must be removed (5.2.5), and the Exhaust Valve Cover.

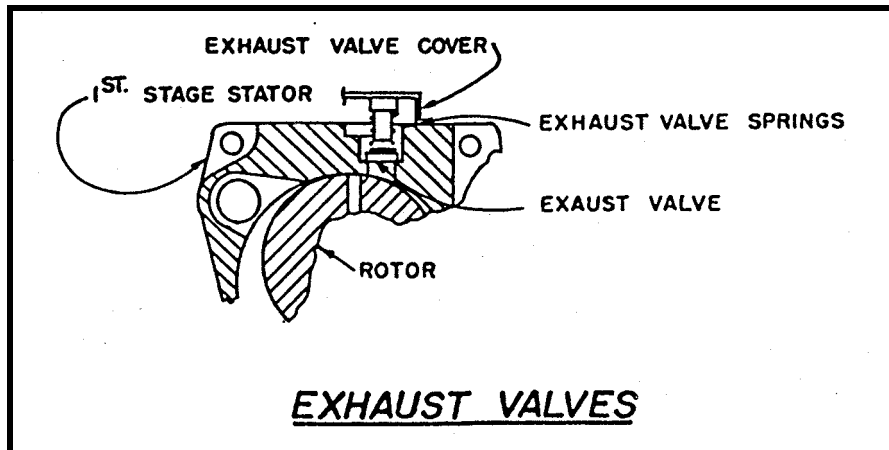

## 5.3 MAJOR SERVICING

**STOP PUMP AND DISCONNECT POWER TO THE PUMP BEFORE SERVICING**

### 5.3.1 "O" ring - inlet flange

Disconnect vacuum line at inlet flange. Unscrew flange or remove four (4) hex head cap screws holding inlet flange to support housing. Remove and replace "O" ring. Reassemble flange to support housing.

### 5.3.2 Oil seals, front plate and end plate

Drain oil. Remove reservoir (5.2.5) Remove pump module:

- a) Remove gas ballast and oil tubing if provided. Remove valve cover and exhaust valve and springs.
- b) Loosen setscrew in pump end of coupling.
- c) Loosen pump module by unscrewing the two socket head cap screws (or hex nuts) which hold the module to the support-upper left and lower right corners when viewed from the pump end.
- d) Remove pump module from support housing, separating the pump coupling half and key from the pump shaft if necessary.

Place pump module vertically on clean surface, using supports to keep weight off pump shaft.



## STOKES VACUUM ROTARY VANE PUMP

Loosen front plate from module by unscrewing the two diagonally opposite socket head cap screws, or the four socket head cap screws. Remove front plate using two brass wedges at the pry slots on each side of the pumps. Take care not to scratch the sealing surfaces of the plates. Damage to these surfaces will cause poor pump performances.

a) Using a wood block to protect the surface and to act as a pivot point, pry the shaft seal from the front plate with a screwdriver.

b) Repeat for rear shaft seal on other side of front plate.

Before installing new oil seals, clean front plate and apply a thin film of lubricating fluid to the oil seals. Press seals in place being careful not to cock the seals.

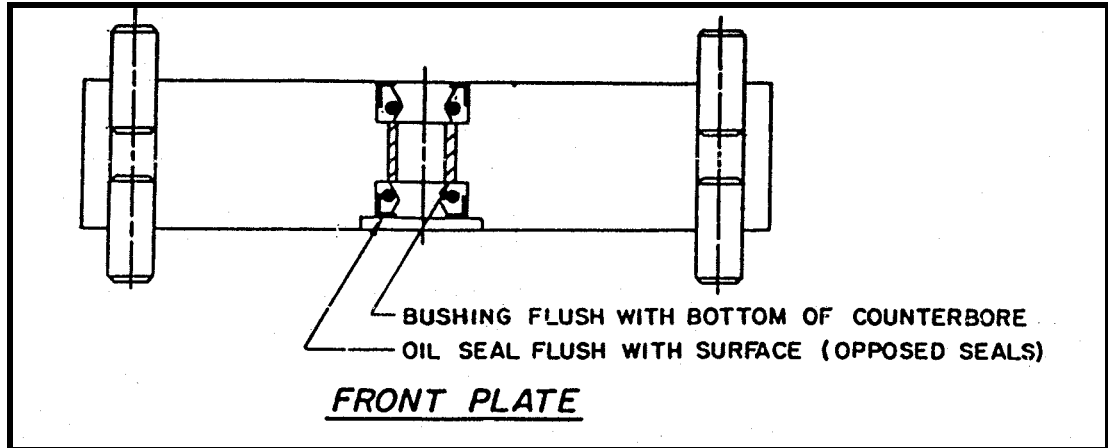

Reassemble front plate to pump taking care not to damage oil seals. The shaft keyway should be covered with a layer of masking tape to prevent cutting the seals. Torque front plate bolts to torque listed in torque table.

To replace end plate oil seals, position pump vertically, drive shaft down, on a clean surface. Use supports to keep weight off pump shaft.

Unscrew and remove bolts holding the Gerotor plate to the end plate. Remove the Gerotor plate.

Remove inner Gerotor element and drive pin. Remove the bolts holding the end plate to the first stage stator. Remove end plate using two brass wedges at the pry slots on each side of the pump. Use care not to scratch the sealing surfaces at the pump. Damage to these surfaces will cause poor pump performance.

Remove Gerotor pump elements from the plate.

Remove end plate oil seal:

a) Using a wood block to protect the surface and to act as a pivot point, pry the oil seal from the plate with a screwdriver.

Before installing new seal, clean the end plate and apply a thin film of lubricating fluid to the seal. Press seal into place being careful not to cock it.

## STOKES VACUUM ROTARY VANE PUMP

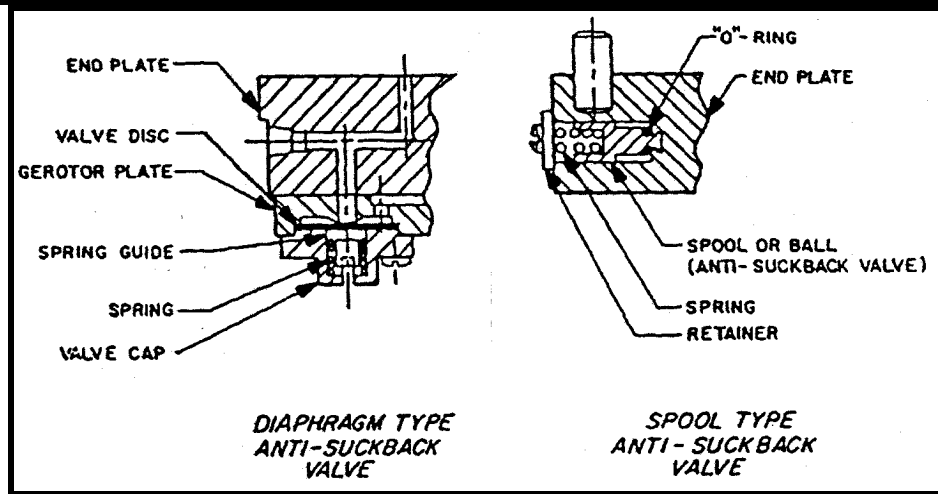

Reassemble end plate to pump with torque listed in torque table.

Install Gerotor drive pin and inner element on pump shaft, lining up the square keyway in the element with the small diameter of the drive pin in the shaft.

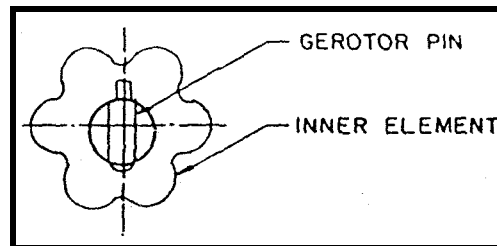

Install outer Gerotor element in the end plate counter bore.

Reassemble Gerotor plate to end plate.

### 5.3.3 Bushing, Front Plate

Follow the procedure for changing oil seals as described in 5.3.2.

After prying out the oil seals, press the bushing out of the front plate, or, if no press is available, tap the bushing out using a hammer and a round bar slightly smaller than the bushing outside diameter.

Install the new bushing:

- Clean the front plate and apply a thin film of lubricating fluid to outside of the bushing.
- Press bushing into front plate. Be sure bushing does not extend into the oil seal counter bores at either end.
- Install replacement oil seals as described in 5.3.2.

### 5.3.4 Bushing, End Plate

Follow procedure for removing end plate oil seals described in 5.3.3.

Press bushing out of end plate, from Gerotor counter bore end, using a round bar slightly larger than the bushing inner diameter.

Install new bushing:

- a) Clean the end plate and apply a thin film of oil to bushing.
- b) Press bushing into end plate from oil seal end, taking care that bearing does not bottom on the shoulder in bearing bore and does not project into the oil seal counter bore.

Install seal as described in 5.3.2.

### 5.3.5 *Bushing Interstage Plate*

Remove end plate as described in 5.3.2.

Remove second stage rotor, taking care not to lose the Gerotor drive pin in the rotor shaft.

Remove second stage stator.

Remove interstage plate.

Press bushing out of interstage plate using a round bar slightly larger than the bushing inner diameter.

Install the new bushing:

- a) Clean the interstage plate and apply a thin film of lubricating fluid to the bushing.
- b) Press bushing into interstage plate, taking care that it does not extend into counter bore on either side of the plate.

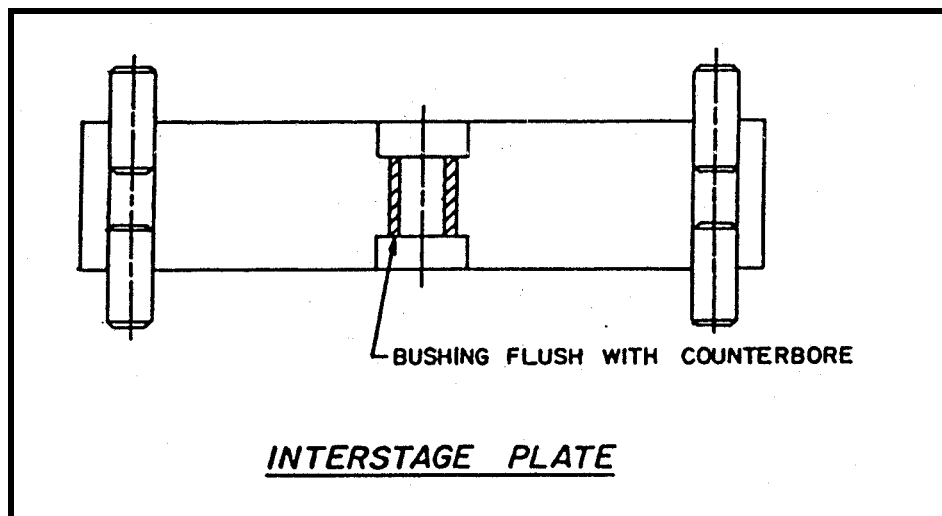

Reassemble interstage plate and second stage stator.

### 5.3.6 *Vanes - First and Second Stage*

Remove gas ballast and oil tubing, if provided.

Remove exhaust valve cover, exhaust valves and springs.

## STOKES VACUUM ROTARY VANE PUMP

Remove pump module by unscrewing the upper left and lower right bolts holding the module to the support housings. (or two shoulder bolts on some pumps). Loosen setscrew in pump half of coupling and slide coupling off shaft as module is removed from support housing.

Place pump vertically on clean supports to keep weight of pump off pump shaft.

Remove Gerotor plate and Gerotor with drive pin (5.3.2) Remove end plate.

Remove second stage rotor by lifting it off the first stage rotor tang.

Remove second stage stator, and then interstage plate. First stage rotor is now exposed.

Lift rotor, with vanes, out of stator. Clean and inspect rotor and stator for scoring. Lightly oil new vanes and install, with springs, into rotor slot. If damaged, return the module to Stokes for repair.

Before installing the rotor into the stator wind a layer of masking tape paper around the shaft at the keyway to protect the oil seals as the shaft is inserted through them.

Liberalily oil the first stage stator with lubricating fluid.

Slightly compress the vane springs and lower the rotor into the stator and through the oil seals being careful to align the rotor against the stator seal as the shaft passes through the front plate oil seals. Do not cock the vanes or damage to springs will result. Install interstage plate over first stage rotor shaft.

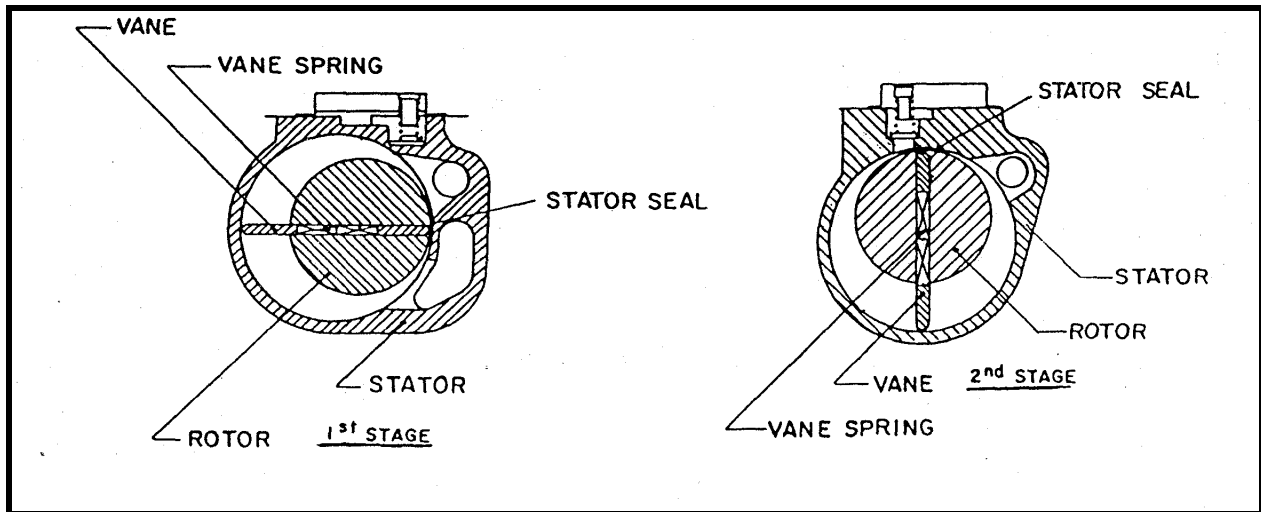

1<sup>st</sup> Stage Model 017-2, 023,2

2<sup>nd</sup> Stage Model 013-2, 017-2, 023-2

## STOKES VACUUM ROTARY VANE PUMP

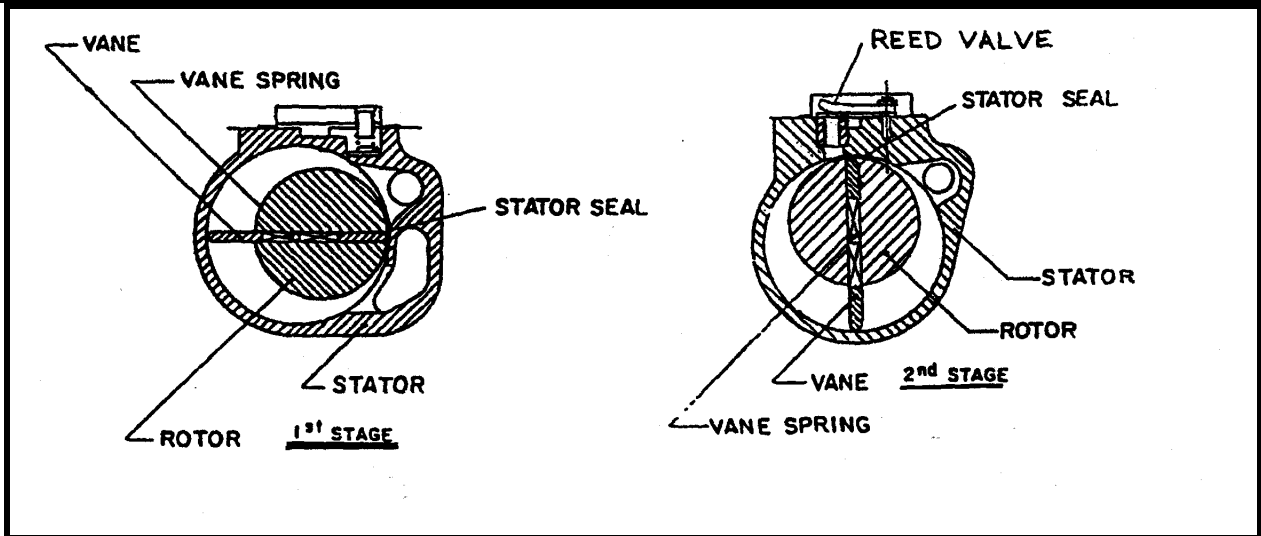

1 <sup>st</sup> Stage	017-3 & 017-4 023-4 & 023-5	2 <sup>nd</sup> Stage	017-3 & 017-4 023-4 & 023-5
-----------------------	--------------------------------	-----------------------	--------------------------------

Clean and inspect second stage stator and rotor for scoring or other damage. Install second stage stator. If damaged, return module to Stokes for repair.

Install lightly oiled vanes, with springs, into second stage rotor slots.

Slightly compress vane springs and install rotor into stator, aligning the rotor against the stator seal and the clevis on the shaft to the tang on the first stage shaft.

Apply lubricating fluid liberally to the second stage stator before installing the end plate over the shaft of the rotor. Tighten end plate bolts to torques listed in bolt torque table.

Install Gerotor drive pin in shaft and slide inner Gerotor element over shaft so that the square keyway in the Gerotor aligns with the small diameter or the pin. (5.3.3)

Install outer Gerotor element in end plate. Install Gerotor plate on end plate. Rotate pump shaft to check for binding.

If pump does not rotate, disassemble to find and correct the cause of the trouble.

Remount the module on the support housing, sliding the coupling, with key onto the shaft as the module is installed. Do not tighten coupling setscrew, but allow coupling half to shaft so that no axial load is applied to push against the pump shaft.

Bolt module to support housing at torques listed in torque table. Slide pump shaft coupling half into engagement with the motor half coupling so that no axial load is transmitted to the pump start. Tighten coupling setscrew.

Install exhaust valves and springs. Install valve cover. Connect gas ballast and oil tubing.

Replace reservoir.

### 5.4 MODULE REPLACEMENT

5.4.1 a) Drain oil. Remove reservoir (5.2.5)

## STOKES VACUUM ROTARY VANE PUMP

- b) Remove gas ballast and oil tubing.
  - c) Loosen set screw in pump end of coupling.
  - d) Loosen pump module by unscrewing the two socket head cap screws (hex nuts) which hold the module to the support housing - upper left and lower right corners when viewed from the pump end, or the two shoulder bolts on some models.
  - e) Remove pump module from support housing, separating the pump coupling half and key from the pump shaft if necessary.
- 5.4.2
- a) Install replacement module to support housing taking care the mating surfaces of the module and support housing are clean and have a light coat of fluid on them.
  - b) Install key and coupling to pump shaft and tighten coupling setscrew.
  - c) Install gas ballast and oil tubing.
  - d) Replace reservoir.

TORQUE TABLE
M6 Soc Head Cap Screw - 104"#
M6 Hex Head Screws - 104"#
M8 Soc Head Cap Screw - 200"#
M8 Hex Head Screws - 200"#
M10 Soc Head Cap Screw - 450"#
M10 Hex Head Screws - 450"#

## STOKES VACUUM ROTARY VANE PUMP

### 5.5 TROUBLESHOOTING GUIDE

CAUSE	SOLUTION
<i>POOR ULTIMATE PRESSURE</i>	
<i>BEFORE ATTEMPTING TO LOCATE THE CAUSE OF POOR ULTIMATE PRESSURE, CHECK THE ACCURACY OF THE VACUUM GAUGES ON THE SYSTEM</i>	
DIRTY FLUID	APPLY FULL GAS BALLAST FOR 2 HOURS AND ALLOW PUMP TO COOL DOWN, THEN RECHECK BLANK-OFF. IF NO IMPROVEMENT, DRAIN, FLUSH AND FILL WITH CLEAN FLUID.
CLOGGED INLET STRAINER	INSPECT AND CLEAN
GAS BALLAST VALVE OPEN. GAS BALLAST TUBE FITTING NOT TIGHT	CLOSE GAS BALLAST VALVE. TIGHTEN NUTS ON FITTING.
LEAKY SEAT OR "O" RING IN GAS BALLAST VALVE	INSPECT AND REPLACE AS REQUIRED.
LEAK IN SYSTEM	LEAK TEST SYSTEM
LEAKING EXHAUST VALVE	INSPECT AND REPLACE VALVES AS REQUIRED.
LEAKING SHAFT SEAL	REPLACE OIL SEAL
<i>RISE IN PUMP NOISE LEVEL</i>	
LOW OIL LEVEL	ADD OIL
LEAKING SHAFT SEAL	REPLACE OIL SEAL
LEAKY SEAT OR "O" RING IN GAS BALLAST VALVE	INSPECT AND REPLACE AS REQUIRED
LEAKING EXHAUST VALVE	REPLACE VALVE
BROKEN VANE OR VANE SPRING	REMOVE MODULE AND REPLACE VANES AND SPRINGS
<i>PUMP STALLS OR STOPS</i>	
MOTOR OVERHEATING	REMOVE PUMP TO COOLER ENVIRONMENT AND TEST

## STOKES VACUUM ROTARY VANE PUMP

BROKEN OR BINDING COUPLING	REMOVE SUPPORT HOUSING SIDECOVER AND INSPECT COUPLING. REPLACE IF NECESSARY.
SEIZED ROTOR	RETURN FOR REPAIR
BROKEN VANE OR FOREIGN OBJECT INGESTED	REMOVE MODULE AND REPLACE OR DISASSEMBLE AND REPAIR PUMP IF POSSIBLE.
<i><b>PUMP FAILS TO START</b></i>	
LOW VOLTAGE OR OVERLOAD	CHECK VOLTAGE AND OVERLOADS
PUMP TOO COLD	WARM PUMP TO AT LEAST 50 DEG. F. (10 DEG. C)
ANTI-SUCK BACK VALVE FAILED TO CLOSE WHEN PUMP STOPPED	CHECK FIT OF VALVE AND REPAIR
BROKEN OR BINDING COUPLING	REMOVE SUPPORT HOUSING SIDECOVER AND INSPECT COUPLING. REPLACE IF NECESSARY.
SEIZED ROTOR	RETURN FOR REPAIR
BROKEN VANE OR FOREIGN OBJECT INGESTED	REMOVE MODULE AND REPLACE OR DISASSEMBLE AND REPAIR PUMP IF POSSIBLE.



## 6.0 VACUUM SYSTEM INSTALLATION

A properly sized pump capable of producing the desired operating pressure in the optimum time is but one of the criteria for a satisfactory installation. In addition to insuring that the pump can handle the gas load and any contaminants present, basic installation procedures should be followed if optimum system performance is to be achieved.

This illustration shows a general installation arrangement in which good engineering practices have been observed. Some components are required only in special situations but most are applicable in a good installation. Adequate space should be provided for access to pump and components for maintenance and service.

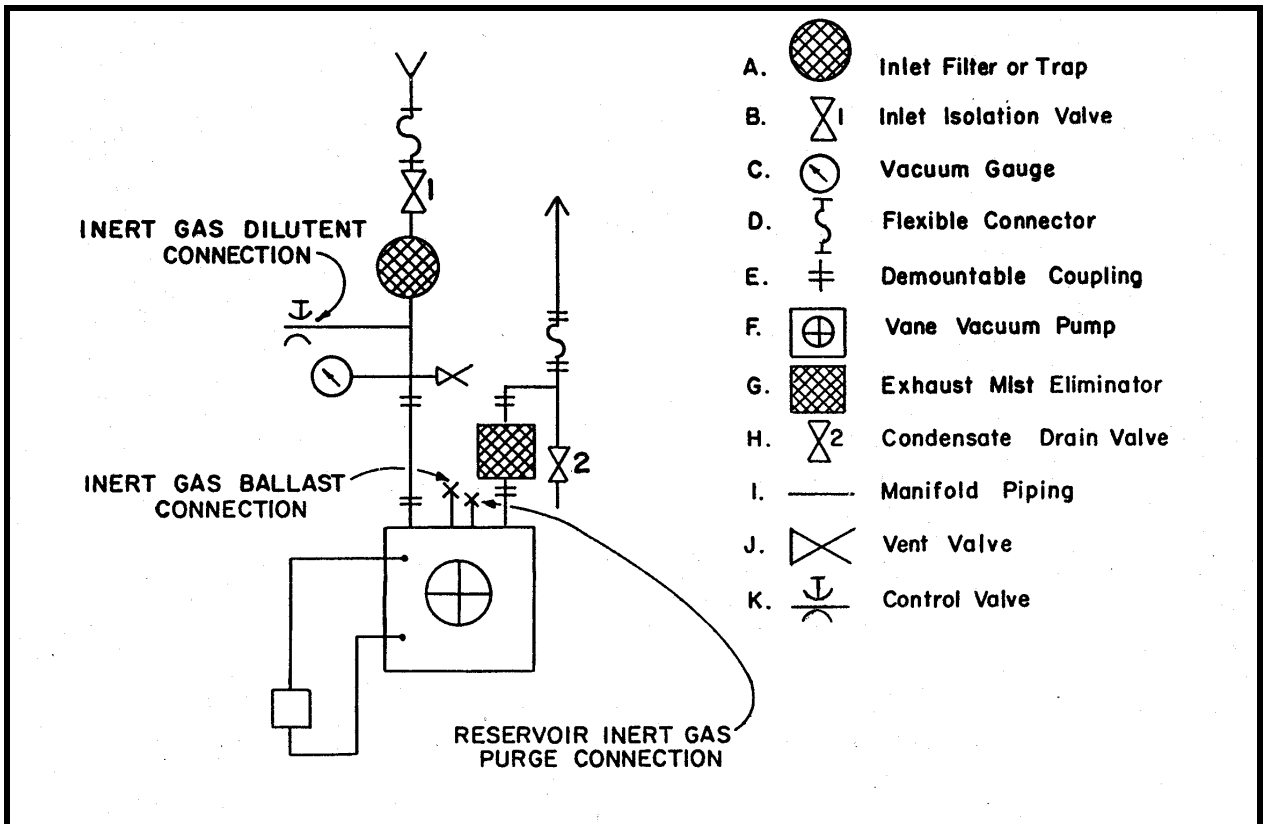

## **7.0 VACUUM SYSTEM ACCESSORIES**

### **7.1 INLET FILTERS**

Processes that have large amounts of particulate matter require filters in the vacuum line between the process and the pump to prevent the particulate from entering the pumps. These filters will reduce pump wear and can decrease oil change intervals and maintenance requirements. Stokes in-line filters can be secured with polyester elements of 4 and 10 micron capacity and 3 micron fiberglass element. For technical information, ask for bulletin 48.

### **7.2 INLET TRAPS**

For processes that require positive means of preventing pump oil from back streaming to the process, Stokes offers two types of inlet traps.

Molecular Sieve Traps prevent the oil from back streaming, but they also remove the moisture from the gas stream. Due to loading with moisture, they require baking to remove water vapor. Bulletin - 44 contains information on these traps.

Stokes also offers Coaxial Traps with wire mesh stainless elements that prevent oil from back streaming to the process. These traps are not sensitive to moisture, and have some ability to remove particulate matter from the process gases. The element can also be furnished in copper. Bulletin 45 contains information on these traps.

### **7.3 OILS**

The vane pumps are furnished with V-Lube "J" oil as standard. This is a general purpose hydrocarbon oil with excellent lubricating qualities and low vapor pressure characteristics that will provide low pump back streaming.

For pumps that are exposed to corrosive environments such as those found in the semi-conductor processes V-Lube "L" has longer service life and will better resist oil breakdown caused by the reactive gases and heat. V-Lube "L" can be ordered from Stokes in sizes from 1 qt. to 55 gal. drums.

For processes that have oxygen-enriched (more than 20% by Vol) exhaust gases synthetic fluids that have no flash or fire point and are inert must be used. These fluids are Fomblin Y06/6 and Krytox 1506. Since these fluids are inert, they can also be used for corrosive applications where an inert oil is required (i.e., Uranium hexafluoride, HCl, BCl<sub>3</sub>, etc). The pump should be purchased cleaned for use with these synthetic fluids.

### **7.4 EXHAUST OIL MIST ELIMINATOR:**

Oil vapors are discharged with the exhaust gases from the pump. The quantity of oil vapors discharged is directly proportional to the pump inlet pressure, the higher the pressure the greater the oil vapor discharged. To remove the oil vapors from the exhaust gases requires that an oil mist eliminator be used. It is attached to the pump exhaust and will remove 99% of the oil vapor in the exhaust gases. For technical information, ask for Bulletin 41.

### **7.5 OIL FILTERING SYSTEMS:**

The vane pump is furnished with an integral automotive type oil filter as part of the pump. This filter has limited holding capacity and will only remove particles 10 microns and larger. For very dirty processes, it is recommended that an external oil filtering system be used. The Stokes 042-2 oil filtering system will remove particles to 0.1 micron and also have the capacity to remove water vapor and acids from the oil. When Fomblin or Krytox is used, oil filtering system 042-013

## STOKES VACUUM ROTARY VANE PUMP

should be used as they are specifically designed for these oils. For very dirty semiconductor applications such as LPCVD or CVD, a large capacity oil filtering system, 330-151 will lengthen the time between oil and filter element changes. All oil filtering systems will lengthen oil and filter element change intervals, reduce pump maintenance and wear, and increase pump life. For technical information on oil purification and filtering systems request Bulletin - 42.

### **7.6 ISO - VACUUM FITTINGS**

Stokes Vane pumps and all the accessories are furnished with ISO Vacuum fittings on the pump inlet and exhaust. Stokes has a full line of fittings from flexible bellows, to elbows, tees, and crosses to connect the pump to the vacuum system and connect the pump to the exhaust system. Bulletin 49 contains information on ISO-KF Vacuum Connectors.

### **7.7 SPECIAL OIL LEVEL INDICATOR**

The standard oil level indicator furnished on the pump is glass. Some processes generate HF acid that will etch the glass. Stokes has available oil level indicators made from polycarbonate that will resist etching by HF, these can be secured from Stokes on special order for field installation.

### **7.8 HIGH VACUUM BLOWERS**

The pumping speed of the vane pump can be increased by placing a high vacuum blower in front of the vane pump. Available sizes are 125, 245 and 400 cfm displacement. The addition of the blower will result in faster pump down to working pressure and the ability to handle large gas loads at low pressures.

STOKES VACUUM ROTARY VANE PUMP

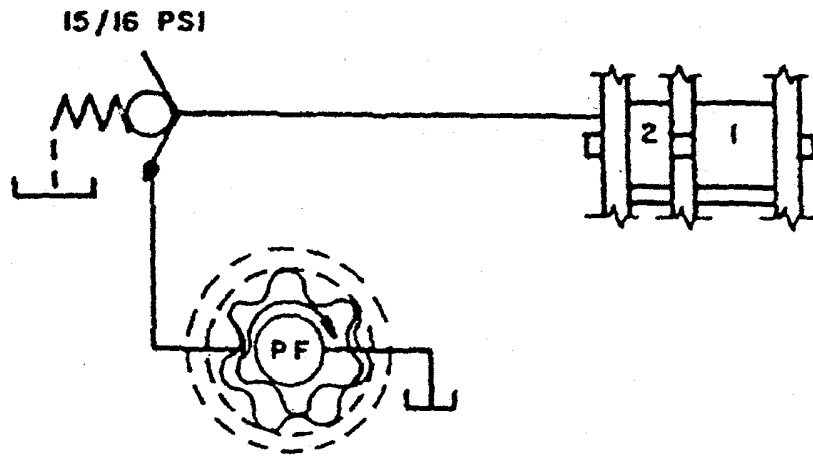

HYDRAULIC DIAGRAM  
(A-428-133-4)  
900-009-2

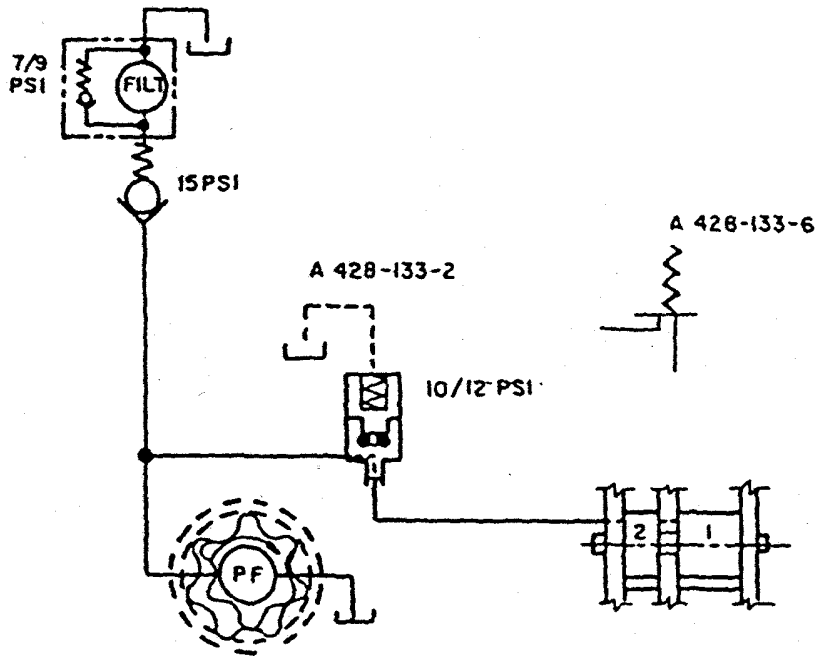

HYDRAULIC DIAGRAM  
(A-428-133-2) (A-428-133-6)

**MODEL 17-3 (37 CFM) ROTARY VANE TYPE VACUUM PUMP W/REED  
 TYPE EXHAUST VALVE**  
**MODEL 17-441 (37 CFM) SPECIAL SERVICE ROTARY VANE TYPE  
 VACUUM PUMP W/REED TYPE EXHAUST VALVE**  
**17-3 LOT NO. SC-78925 TO**  
**17-441 LOT NO. SC-79028 TO**

SYM	PART NO.	DESCRIPTION	REF. DWG/ COMP. LIT.	QTY	UM	RSP
NOTE FOR -441 PUMPS ONLY: When ordering parts for your Rotary Vane Pump, please specify that your pump is being used for Special Service						
	424-078-002	MINOR SERVICING REPLACEMENT PARTS KIT CONSISTS OF:		1	EA	
1	429-345-001	EXHAUST VALVE		3	EA	
2	429-314-001	EXHAUST VALVE SPRING		3	EA	
3	085-037-672	O RING (FILL/DRAIN PLUG)		2	EA	
4	085-039-252	O RING (GAS BALLAST)		1	EA	
5	427-716-001	GAS BALLAST VALVE DISC		1	EA	
6	085-039-191	O RING (INLET SCREEN)		1	EA	
7	427-749-001	RESERVOIR GASKET	OLD STYLE NO LONGER USED	1	EA	
7A	085-040-225	RESERVOIR GASKET O RING TYPE VITON	CURRENT STYLE	1	EA	
7B	085-042-506	<b>REED VALVE ASSEMBLY CONSISTING OF:</b>		1	EA	
	085-045-870	SPL. STL. REED		1	EA	
	085-045-871	STL. RETAINER		1	EA	
	085-045-872	CAP SCREW		1	EA	
	085-045-873	WASHER		1	EA	
7C	085-047-237	ROLL PIN		1	EA	

RSP = RECOMMENDED SPARE PART  
 UM = UNIT OF MEASURE

**MODEL 17-3 (37 CFM) ROTARY VANE TYPE VACUUM PUMP W/REED  
TYPE EXHAUST VALVE**

**MODEL 17-441 (37 CFM) SPECIAL SERVICE ROTARY VANE TYPE  
VACUUM PUMP W/REED TYPE EXHAUST VALVE**

**17-3 LOT NO. SC-78925 TO  
17-441 LOT NO. SC-79028 TO**

SYM	PART NO.	DESCRIPTION	REF. DWG/ COMP. LIT.	QTY	UM	RSP
NOTE FOR -441 PUMPS ONLY: When ordering parts for your Rotary Vane Pump, please specify that your pump is being used for Special Service						
	424-079-001	MAJOR SERVICING REPLACEMENT PARTS KIT CONSISTS OF:		1	EA	
8	428-217-001	BUSHING (END PLATE)		1	EA	
9	085-039-263	OIL SEAL (END PLATE)		1	EA	
10	428-219-001	BUSHING (FRONT PLATE)		1	EA	
11	085-039-187	OIL SEAL (FRONT PLATE)		2	EA	
12	428-218-001	BUSHING (INTERSTAGE PLATE)		1	EA	
13	085-027-613	O RING (GAS BALLAST)		1	EA	
14	085-040-204	O RING (GAS BALLAST)		1	EA	
15	085-037-672	O RING (GAS BALLAST)		1	EA	
16	085-039-235	O RING (SUPPORT HOUSING)		1	EA	
17	085-018-635	O RING (INLET FLANGE)		1	EA	
18	427-647-002	GEROTOR DRIVE PIN		1	EA	
19	085-040-351	BALL FILTER RELIEF VALVE		1	EA	
20	427-649-001	ROTOR KEY		1	EA	
21	429-925-001	VALVE DISC		1	EA	
23	085-040-224	SPRING		1	EA	
24	085-039-279	SPRING FILTER RELIEF VALVE		1	EA	
25	427-607-007	1ST STAGE VANE		2	EA	
26	427-608-005	2ND STAGE VANE		2	EA	
27	085-039-280	SPRING (1ST & 2ND STAGE VANE)		6	EA	
29	085-040-605	HYTRELL SPIDER		1	EA	

RSP = RECOMMENDED SPARE PART  
UM = UNIT OF MEASURE

MODEL 17-3 (37 CFM) ROTARY VANE TYPE VACUUM PUMP W/REED  
TYPE EXHAUST VALVE

MODEL 17-441 (37 CFM) SPECIAL SERVICE ROTARY VANE TYPE  
VACUUM PUMP W/REED TYPE EXHAUST VALVE

17-3 LOT NO. SC-78925 TO  
17-441 LOT NO. SC-79028 TO

SYM	PART NO.	DESCRIPTION	REF. DWG/ COMP. LIT.	QTY	UM	RSP
NOTE FOR -441 PUMPS ONLY: When ordering parts for your Rotary Vane Pump, please specify that your pump is being used for Special Service						
30	428-654-001	SYNTHETIC FLUID MODLE ASSEMBLY		1	EA	
31	427-297-004	SUPPORT HOUSING		1	EA	
31A	427-295-001	MOTOR ADAPTER		1	EA	
31B	600-640-002	SUPPORT HOUSING FOOT RH		1	EA	
31B	600-640-003	SUPPORT HOUSING FOOT LH		1	EA	
32	085-039-018	RUBBER BUMPER		4	EA	
33	427-272-003	FRONT PLATE		1	EA	
34	427-273-003	1ST STAGE STATOR		1	EA	
35	427-274-003	INTERSTATE PLATE		1	EA	
36	427-275-005	2ND STAGE STATOR		1	EA	
37	427-276-005	END PLATE		1	EA	
38	427-285-003	RESERVOIR		1	EA	
39	427-706-001	FAN - 6-1/2 DIA.		1	EA	
40	427-643-002	COUPLING (MOTOR DRIVE)		1	EA	
41	600-058-001	ROTOR, 1ST STAGE		1	EA	
42	600-059-001	ROTOR, 2ND STAGE		1	EA	
43	085-039-267	GEROTOR ASSEMBLY		1	EA	
44	429-926-002	GEROTOR COVER		1	EA	
45	427-717-006	SIDE COVER		2	EA	
46	429-639-001	OIL FILTER		1	EA	✓
47	427-725-001	OIL FILTER THREADED TUBE		1	EA	
48	427-636-001	INLET SCREEN ASSEMBLY		1	EA	
49	427-645-001	INLET FLANGE		1	EA	

RSP = RECOMMENDED SPARE PART  
UM = UNIT OF MEASURE

**MODEL 17-3 (37 CFM) ROTARY VANE TYPE VACUUM PUMP W/REED  
TYPE EXHAUST VALVE  
MODEL 17-441 (37 CFM) SPECIAL SERVICE ROTARY VANE TYPE  
VACUUM PUMP W/REED TYPE EXHAUST VALVE  
17-3 LOT NO. SC-78925 TO  
17-441 LOT NO. SC-79028 TO**

SYM	PART NO.	DESCRIPTION	REF. DWG/ COMP. LIT.	QTY	UM	RSP
<b>NOTE FOR -441 PUMPS ONLY: When ordering parts for your Rotary Vane Pump, please specify that your pump is being used for Special Service</b>						
50	428-224-001	EXHAUST FLANGE		1	EA	
51	427-734-004	EXHAUST VALVE COVER ASSEMBLY		1	EA	
52	428-116-001	GAS BALLAST VALVE CAP		1	EA	
53	428-117-001	GAS BALLAST VALVE BODY		1	EA	
54	428-226-001	GAS BALLAST TUBE		1	EA	
55	429-486-001	OIL TUBE		1	EA	
56	429-923-003	VALVE CAP		2	EA	
57	429-924-001	SPRING TUBE (GUIDE)		1	EA	
58	075-033-472	PLUG (FILL)		1	EA	
59	075-033-472	PLUG (DRAIN)		1	EA	
60	427-700-001	OIL SLINGER		1	EA	
61	085-037-922	SIGHT GLASS GAUGE, WINDOW TYPE		1	EA	
61A	085-039-900	SIGHT GLASS (POLYCARBONATE)		1	EA	
	601-868-001	REED VALVE BUSHING		1	EA	
	429-345-001	VALVE, EXHAUST CAM		3	EA	
	427-995-001	MOTOR KEY (NOT SHOWN)		1	EA	
	085-039-402	OIL, V-LUBE J	STANDARD SERVICE USE ONLY	1	GAL	✓
	085-039-403	OIL V-LUBE J	STANDARD SERVICE USE ONLY	1	QT	✓

RSP = RECOMMENDED SPARE PART  
UM = UNIT OF MEASURE



**MODEL 17-3 (37 CFM) ROTARY VANE TYPE VACUUM PUMP W/REED  
TYPE EXHAUST VALVE  
MODEL 17-441 (37 CFM) SPECIAL SERVICE ROTARY VANE TYPE  
VACUUM PUMP W/REED TYPE EXHAUST VALVE  
17-3 LOT NO. SC-78925 TO  
17-441 LOT NO. SC-79028 TO**

SYM	PART NO.	DESCRIPTION	REF. DWG/ COMP. LIT.	QTY	UM	RSP
NOTE FOR -441 PUMPS ONLY: When ordering parts for your Rotary Vane Pump, please specify that your pump is being used for Special Service						
	085-045-742	OIL, Y LUBE 25/6	SPECIAL SERVICE USE ONLY	1	GAL	✓
	085-042-506	REED VALVE ASSEMBLY		3	EA	✓
REFERENCE DRAWINGS						
	A-428-133-006 B-0-329	HYDRAULIC DIAGRAM EXPLODED VIEW				

RSP = RECOMMENDED SPARE PART  
UM = UNIT OF MEASURE

**MODEL 17-4 (37 CFM) ROTARY VANE TYPE VACUUM PUMP W/REED  
 TYPE EXHAUST VALVE**  
**MODEL 17-444 (37 CFM) SPECIAL SERVICE ROTARY VANE TYPE  
 VACUUM PUMP W/REED TYPE EXHAUST VALVE**  
**17-4 LOT NO. 79068 TO**  
**17-444 LOT NO. 79069 TO**

SYM	PART NO.	DESCRIPTION	REF. DWG/ COMP. LIT.	QTY	UM	RSP
NOTE FOR -444 PUMPS ONLY: When ordering parts for your Rotary Vane Pump, please specify that your pump is being used for Special Service						
	424-078-002	MINOR SERVICING REPLACEMENT PARTS KIT CONSISTS OF:		1	EA	
1	429-345-001	EXHAUST VALVE		3	EA	
2	429-314-001	EXHAUST VALVE SPRING		3	EA	
3	085-037-672	O RING (FILL/DRAIN PLUG)		2	EA	
4	085-039-252	O RING (GAS BALLAST)		1	EA	
5	427-716-001	GAS BALLAST VALVE DISC		1	EA	
6	085-039-191	O RING (INLET SCREEN)		1	EA	
7A	085-040-225	RESERVOIR GASKET O RING TYPE VITON		1	EA	
7B	085-042-506	<b>REED VALVE ASSEMBLY CONSISTING OF:</b>		1	EA	
	085-045-870	SPL. STL. REED		1	EA	
	085-045-871	STL. RETAINER		1	EA	
	085-045-872	CAP SCREW		1	EA	
	085-045-873	WASHER		1	EA	
7C	085-047-237	ROLL PIN		2	EA	
		MAJOR SERVICING REPLACEMENT PARTS KIT CONSISTS OF:		1	EA	
8	428-217-001	BUSHING (END PLATE)		1	EA	
9	085-039-263	OIL SEAL (END PLATE)		1	EA	
10	428-219-001	BUSHING (FRONT PLATE)		1	EA	

RSP = RECOMMENDED SPARE PART  
 UM = UNIT OF MEASURE

**MODEL 17-4 (37 CFM) ROTARY VANE TYPE VACUUM PUMP W/REED  
TYPE EXHAUST VALVE  
MODEL 17-444 (37 CFM) SPECIAL SERVICE ROTARY VANE TYPE  
VACUUM PUMP W/REED TYPE EXHAUST VALVE  
17-4 LOT NO. 79068 TO  
17-444 LOT NO. 79069 TO**

SYM	PART NO.	DESCRIPTION	REF. DWG/ COMP. LIT.	QTY	UM	RSP
NOTE FOR -444 PUMPS ONLY: When ordering parts for your Rotary Vane Pump, please specify that your pump is being used for Special Service						
11	085-039-187	OIL SEAL (FRONT PLATE)		2	EA	
12	085-051-074	BUSHING (INTERSTAGE PLATE)		1	EA	
13	085-027-613	O RING (GAS BALLAST)		1	EA	
14	085-040-204	O RING (GAS BALLAST)		1	EA	
15	085-037-672	O RING (GAS BALLAST)		1	EA	
16	085-039-235	O RING (SUPPORT HOUSING)		1	EA	
17	085-018-635	O RING (INLET FLANGE)		1	EA	
18	427-647-002	GEROTOR DRIVE PIN		1	EA	
19	085-040-351	BALL FILTER RELIEF VALVE		1	EA	
20	427-649-001	ROTOR KEY		1	EA	
21	429-925-001	VALVE DISC		1	EA	
23	085-040-224	SPRING		1	EA	
24	085-039-279	SPRING FILTER RELIEF VALVE		1	EA	
25	427-607-007	1ST STAGE VANE		2	EA	
26	427-608-005	2ND STAGE VANE		2	EA	
27	085-039-280	SPRING (1ST & 2ND STAGE VANE)		6	EA	
29	085-040-605	HYTRELL SPIDER		1	EA	
30		MODLE ASSEMBLY		1	EA	
31	427-297-004	SUPPORT HOUSING		1	EA	
31A	427-295-001	MOTOR ADAPTER		1	EA	
31B	600-640-002	SUPPORT HOUSING FOOT RH		1	EA	
31B	600-640-003	SUPPORT HOUSING FOOT LH		1	EA	

RSP = RECOMMENDED SPARE PART  
UM = UNIT OF MEASURE

**MODEL 17-4 (37 CFM) ROTARY VANE TYPE VACUUM PUMP W/REED  
TYPE EXHAUST VALVE  
MODEL 17-444 (37 CFM) SPECIAL SERVICE ROTARY VANE TYPE  
VACUUM PUMP W/REED TYPE EXHAUST VALVE  
17-4 LOT NO. 79068 TO  
17-444 LOT NO. 79069 TO**

SYM	PART NO.	DESCRIPTION	REF. DWG/ COMP. LIT.	QTY	UM	RSP
<b>NOTE FOR -444 PUMPS ONLY: When ordering parts for your Rotary Vane Pump, please specify that your pump is being used for Special Service</b>						
32	085-039-018	RUBBER BUMPER		4	EA	
33	427-272-003	FRONT PLATE		1	EA	
34	427-273-003	1ST STAGE STATOR		1	EA	
35	427-274-004	INTERSTATE PLATE		1	EA	
36	427-275-005	2ND STAGE STATOR		1	EA	
37	427-276-005	END PLATE		1	EA	
38	427-285-003	RESERVOIR		1	EA	
39	427-706-001	FAN - 6-1/2 DIA.		1	EA	
40	427-643-002	COUPLING (MOTOR DRIVE)		1	EA	
41	600-058-004	ROTOR, 1ST STAGE		1	EA	
42	600-059-004	ROTOR, 2ND STAGE		1	EA	
43	085-039-267	GEROTOR ASSEMBLY		1	EA	
44	429-926-002	GEROTOR COVER		1	EA	
45	427-717-006	SIDE COVER		2	EA	
46	429-639-001	OIL FILTER		1	EA	✓
47	427-725-001	OIL FILTER THREADED TUBE		1	EA	
48	427-636-001	INLET SCREEN ASSEMBLY		1	EA	
49	427-645-001	INLET FLANGE		1	EA	

RSP = RECOMMENDED SPARE PART  
UM = UNIT OF MEASURE

**MODEL 17-4 (37 CFM) ROTARY VANE TYPE VACUUM PUMP W/REED  
TYPE EXHAUST VALVE  
MODEL 17-444 (37 CFM) SPECIAL SERVICE ROTARY VANE TYPE  
VACUUM PUMP W/REED TYPE EXHAUST VALVE  
17-4 LOT NO. 79068 TO  
17-444 LOT NO. 79069 TO**

SYM	PART NO.	DESCRIPTION	REF. DWG/ COMP. LIT.	QTY	UM	RSP
NOTE FOR -444 PUMPS ONLY: When ordering parts for your Rotary Vane Pump, please specify that your pump is being used for Special Service						
50	428-224-001	EXHAUST FLANGE		1	EA	
51	427-734-004	EXHAUST VALVE COVER ASSEMBLY		1	EA	
52	428-116-001	GAS BALLAST VALVE CAP		1	EA	
53	428-117-001	GAS BALLAST VALVE BODY		1	EA	
54	428-226-001	GAS BALLAST TUBE		1	EA	
55	429-486-001	OIL TUBE		1	EA	
56	429-923-003	VALVE CAP		2	EA	
57	429-924-001	SPRING TUBE (GUIDE)		1	EA	
58	075-033-472	PLUG (FILL)		1	EA	
59	075-033-472	PLUG (DRAIN)		1	EA	
60	427-700-001	OIL SLINGER		1	EA	
61	085-037-922	SIGHT GLASS GAUGE, WINDOW TYPE		1	EA	
61A	085-039-900	SIGHT GLASS (POLYCARBONATE)		1	EA	
	601-868-001	REED VALVE BUSHING		1	EA	
	429-345-001	VALVE, EXHAUST CAM		3	EA	
	427-995-001	MOTOR KEY (NOT SHOWN)		1	EA	
	085-039-402	OIL, V-LUBE J	STANDARD SERVICE USE ONLY	1	GAL	✓

RSP = RECOMMENDED SPARE PART  
UM = UNIT OF MEASURE



**MODEL 23-4 (55 CFM) ROTARY VANE TYPE VACUUM PUMP W/REED  
 TYPE EXHAUST VALVE**  
**MODEL 23-441 (55 CFM) SPECIAL SERVICE ROTARY VANE TYPE  
 VACUUM PUMP W/REED TYPE EXHAUST VALVE**  
**23-4 LOT NO. SC-79044 TO**  
**23-441 LOT NO. SC-79045 TO**

SYM	PART NO.	DESCRIPTION	REF. DWG/ COMP. LIT.	QTY	UM	RSP
NOTE FOR -441 PUMPS ONLY: When ordering parts for your Rotary Vane Pump, please specify that your pump is being used for Special Service						
	424-078-002	MINOR SERVICING REPLACEMENT PARTS KIT CONSISTS OF:		1	EA	
1	429-345-001	EXHAUST VALVE		3	EA	
2	429-314-001	EXHAUST VALVE SPRING		3	EA	
3	085-037-672	O RING (FILL/DRAIN PLUG)		2	EA	
4	085-039-252	O RING (GAS BALLAST)		1	EA	
5	427-716-001	GAS BALLAST VALVE DISC		1	EA	
6	085-039-191	O RING (INLET SCREEN)		1	EA	
7	427-749-001	RESERVOIR GASKET	OLD STYLE NO LONGER USED	1	EA	
7A	085-040-225	RESERVOIR GASKET O RING TYPE VITON	CURRENT STYLE	1	EA	
7B	085-042-506	<b>REED VALVE ASSEMBLY CONSISTING OF:</b>		1	EA	
	085-045-870	SPL. STL. REED		1	EA	
	085-045-871	STL. RETAINER		1	EA	
	085-045-872	CAP SCREW		1	EA	
	085-045-873	WASHER		1	EA	
7C	085-047-237	ROLL PIN		1	EA	

RSP = RECOMMENDED SPARE PART  
 UM = UNIT OF MEASURE

**MODEL 23-4 (55 CFM) ROTARY VANE TYPE VACUUM PUMP W/REED  
TYPE EXHAUST VALVE  
MODEL 23-441 (55 CFM) SPECIAL SERVICE ROTARY VANE TYPE  
VACUUM PUMP W/REED TYPE EXHAUST VALVE  
23-4 LOT NO. SC-79044 TO  
23-441 LOT NO. SC-79045 TO**

SYM	PART NO.	DESCRIPTION	REF. DWG/ COMP. LIT.	QTY	UM	RSP
NOTE FOR -441 PUMPS ONLY: When ordering parts for your Rotary Vane Pump, please specify that your pump is being used for Special Service						
	424-079-001	MAJOR SERVICING REPLACEMENT PARTS KIT CONSISTS OF:		1	EA	
8	428-217-001	BUSHING (END PLATE)		1	EA	
9	085-039-263	OIL SEAL (END PLATE)		1	EA	
10	428-219-001	BUSHING (FRONT PLATE)		1	EA	
11	085-039-187	OIL SEAL (FRONT PLATE)		2	EA	
12	428-218-001	BUSHING (INTERSTAGE PLATE)		1	EA	
13	085-027-613	O RING (GAS BALLAST)		1	EA	
14	085-040-204	O RING (GAS BALLAST)		1	EA	
15	085-037-672	O RING (GAS BALLAST)		1	EA	
16	085-039-235	O RING (SUPPORT HOUSING)		1	EA	
17	085-018-635	O RING (INLET FLANGE)		1	EA	
18	427-647-002	GEROTOR DRIVE PIN		1	EA	
19	085-040-351	BALL FILTER RELIEF VALVE		1	EA	
20	427-649-001	ROTOR KEY		1	EA	
21	429-925-001	VALVE DISC		1	EA	
23	085-040-224	SPRING		1	EA	
24	085-039-279	SPRING FILTER RELIEF VALVE		1	EA	
25	427-607-007	1ST STAGE VANE		2	EA	
26	427-608-005	2ND STAGE VANE		2	EA	
27	085-039-280	SPRING (1ST & 2ND STAGE VANE)		6	EA	
29	085-040-605	HYTRELL SPIDER		1	EA	

RSP = RECOMMENDED SPARE PART  
UM = UNIT OF MEASURE



**MODEL 23-4 (55 CFM) ROTARY VANE TYPE VACUUM PUMP W/REED  
TYPE EXHAUST VALVE  
MODEL 23-441 (55 CFM) SPECIAL SERVICE ROTARY VANE TYPE  
VACUUM PUMP W/REED TYPE EXHAUST VALVE  
23-4 LOT NO. SC-79044 TO  
23-441 LOT NO. SC-79045 TO**

SYM	PART NO.	DESCRIPTION	REF. DWG/ COMP. LIT.	QTY	UM	RSP
NOTE FOR -441 PUMPS ONLY: When ordering parts for your Rotary Vane Pump, please specify that your pump is being used for Special Service						
30	428-654-001	SYNTHETIC FLUID MODLE ASSEMBLY		1	EA	
31	427-297-004	SUPPORT HOUSING		1	EA	
31A	427-295-001	MOTOR ADAPTER		1	EA	
31B	600-640-002	SUPPORT HOUSING FOOT RH		1	EA	
31B	600-640-003	SUPPORT HOUSING FOOT LH		1	EA	
32	085-039-018	RUBBER BUMPER		4	EA	
33	427-272-003	FRONT PLATE		1	EA	
34	427-273-003	1ST STAGE STATOR		1	EA	
35	427-274-003	INTERSTATE PLATE		1	EA	
36	427-275-005	2ND STAGE STATOR		1	EA	
37	427-276-005	END PLATE		1	EA	
38	427-285-003	RESERVOIR		1	EA	
39	427-706-001	FAN - 6-1/2 DIA.		1	EA	
40	427-643-002	COUPLING (MOTOR DRIVE)		1	EA	
41	600-058-001	ROTOR, 1ST STAGE		1	EA	
42	600-059-001	ROTOR, 2ND STAGE		1	EA	
43	085-039-267	GEROTOR ASSEMBLY		1	EA	
44	429-926-002	GEROTOR COVER		1	EA	
45	427-717-006	SIDE COVER		2	EA	
46	429-639-001	OIL FILTER		1	EA	✓
47	427-725-001	OIL FILTER THREADED TUBE		1	EA	
48	427-636-001	INLET SCREEN ASSEMBLY		1	EA	
49	427-645-001	INLET FLANGE		1	EA	

RSP = RECOMMENDED SPARE PART  
UM = UNIT OF MEASURE

**MODEL 23-4 (55 CFM) ROTARY VANE TYPE VACUUM PUMP W/REED  
TYPE EXHAUST VALVE  
MODEL 23-441 (55 CFM) SPECIAL SERVICE ROTARY VANE TYPE  
VACUUM PUMP W/REED TYPE EXHAUST VALVE  
23-4 LOT NO. SC-79044 TO  
23-441 LOT NO. SC-79045 TO**

SYM	PART NO.	DESCRIPTION	REF. DWG/ COMP. LIT.	QTY	UM	RSP
<b>NOTE FOR -441 PUMPS ONLY: When ordering parts for your Rotary Vane Pump, please specify that your pump is being used for Special Service</b>						
50	428-224-001	EXHAUST FLANGE		1	EA	
51	427-734-004	EXHAUST VALVE COVER ASSEMBLY		1	EA	
52	428-116-001	GAS BALLAST VALVE CAP		1	EA	
53	428-117-001	GAS BALLAST VALVE BODY		1	EA	
54	428-226-001	GAS BALLAST TUBE		1	EA	
55	429-486-001	OIL TUBE		1	EA	
56	429-923-003	VALVE CAP		2	EA	
57	429-924-001	SPRING TUBE (GUIDE)		1	EA	
58	075-033-472	PLUG (FILL)		1	EA	
59	075-033-472	PLUG (DRAIN)		1	EA	
60	427-700-001	OIL SLINGER		1	EA	
61	085-037-922	SIGHT GLASS GAUGE, WINDOW TYPE		1	EA	
61A	085-039-900	SIGHT GLASS (POLYCARBONATE)		1	EA	
	601-868-001	REED VALVE BUSHING		1	EA	
	429-345-001	VALVE, EXHAUST CAM		3	EA	
	427-995-001	MOTOR KEY (NOT SHOWN)		1	EA	
	085-039-402	OIL, V-LUBE J	STANDARD SERVICE USE ONLY	1	GAL	✓
	085-039-403	OIL V-LUBE J	STANDARD SERVICE USE ONLY	1	QT	✓

RSP = RECOMMENDED SPARE PART  
UM = UNIT OF MEASURE

**MODEL 23-4 (55 CFM) ROTARY VANE TYPE VACUUM PUMP W/REED  
TYPE EXHAUST VALVE**

**MODEL 23-441 (55 CFM) SPECIAL SERVICE ROTARY VANE TYPE  
VACUUM PUMP W/REED TYPE EXHAUST VALVE**

**23-4 LOT NO. SC-79044 TO  
23-441 LOT NO. SC-79045 TO**

SYM	PART NO.	DESCRIPTION	REF. DWG/ COMP. LIT.	QTY	UM	RSP
<b>NOTE FOR -441 PUMPS ONLY: When ordering parts for your Rotary Vane Pump, please specify that your pump is being used for Special Service</b>						
	085-045-742	OIL, Y LUBE 25/6	SPECIAL SERVICE USE ONLY	1	GAL	✓
	085-042-506	REED VALVE ASSEMBLY		3	EA	✓
<b>REFERENCE DRAWINGS</b>						
	A-428-133-006 B-0-329	HYDRAULIC DIAGRAM EXPLODED VIEW				

RSP = RECOMMENDED SPARE PART  
UM = UNIT OF MEASURE

**MODEL 23-5 (55 CFM) ROTARY VANE TYPE VACUUM PUMP W/REED  
 TYPE EXHAUST VALVE**  
**MODEL 23-445 (55 CFM) SPECIAL SERVICE ROTARY VANE TYPE  
 VACUUM PUMP W/REED TYPE EXHAUST VALVE**  
**23-5 LOT NO. 79070 TO**  
**23-445 LOT NO. 79071 TO**

SYM	PART NO.	DESCRIPTION	REF. DWG/ COMP. LIT.	QTY	UM	RSP
NOTE FOR -444 PUMPS ONLY: When ordering parts for your Rotary Vane Pump, please specify that your pump is being used for Special Service						
	424-078-002	MINOR SERVICING REPLACEMENT PARTS KIT CONSISTS OF:		1	EA	
1	429-345-001	EXHAUST VALVE		3	EA	
2	429-314-001	EXHAUST VALVE SPRING		3	EA	
3	085-037-672	O RING (FILL/DRAIN PLUG)		2	EA	
4	085-039-252	O RING (GAS BALLAST)		1	EA	
5	427-716-001	GAS BALLAST VALVE DISC		1	EA	
6	085-039-191	O RING (INLET SCREEN)		1	EA	
7A	085-040-225	RESERVOIR GASKET O RING TYPE VITON		1	EA	
7B	085-042-506	<b>REED VALVE ASSEMBLY CONSISTING OF:</b>		1	EA	
	085-045-870	SPL. STL. REED		1	EA	
	085-045-871	STL. RETAINER		1	EA	
	085-045-872	CAP SCREW		1	EA	
	085-045-873	WASHER		1	EA	
7C	085-047-237	ROLL PIN		2	EA	
		MAJOR SERVICING REPLACEMENT PARTS KIT CONSISTS OF:		1	EA	
8	428-217-001	BUSHING (END PLATE)		1	EA	
9	085-039-263	OIL SEAL (END PLATE)		1	EA	
10	428-219-001	BUSHING (FRONT PLATE)		1	EA	

RSP = RECOMMENDED SPARE PART  
 UM = UNIT OF MEASURE

**MODEL 23-5 (55 CFM) ROTARY VANE TYPE VACUUM PUMP W/REED  
TYPE EXHAUST VALVE  
MODEL 23-445 (55 CFM) SPECIAL SERVICE ROTARY VANE TYPE  
VACUUM PUMP W/REED TYPE EXHAUST VALVE  
23-5 LOT NO. 79070 TO  
23-445 LOT NO. 79071 TO**

SYM	PART NO.	DESCRIPTION	REF. DWG/ COMP. LIT.	QTY	UM	RSP
NOTE FOR -444 PUMPS ONLY: When ordering parts for your Rotary Vane Pump, please specify that your pump is being used for Special Service						
11	085-039-187	OIL SEAL (FRONT PLATE)		2	EA	
12	085-051-074	BUSHING (INTERSTAGE PLATE)		1	EA	
13	085-027-613	O RING (GAS BALLAST)		1	EA	
14	085-040-204	O RING (GAS BALLAST)		1	EA	
15	085-037-672	O RING (GAS BALLAST)		1	EA	
16	085-039-235	O RING (SUPPORT HOUSING)		1	EA	
17	085-018-635	O RING (INLET FLANGE)		1	EA	
18	427-647-002	GEROTOR DRIVE PIN		1	EA	
19	085-040-351	BALL FILTER RELIEF VALVE		1	EA	
20	427-649-001	ROTOR KEY		1	EA	
21	429-925-001	VALVE DISC		1	EA	
23	085-040-224	SPRING		1	EA	
24	085-039-279	SPRING FILTER RELIEF VALVE		1	EA	
25	427-607-007	1ST STAGE VANE		2	EA	
26	427-608-005	2ND STAGE VANE		2	EA	
27	085-039-280	SPRING (1ST & 2ND STAGE VANE)		6	EA	
29	085-040-605	HYTRELL SPIDER		1	EA	
30		SYNTHETIC FLUID MODLE ASSEMBLY		1	EA	
31	427-297-004	SUPPORT HOUSING		1	EA	
31A	427-295-001	MOTOR ADAPTER		1	EA	
31B	600-640-002	SUPPORT HOUSING FOOT RH		1	EA	
31B	600-640-003	SUPPORT HOUSING FOOT LH		1	EA	

RSP = RECOMMENDED SPARE PART  
UM = UNIT OF MEASURE

**MODEL 23-5 (55 CFM) ROTARY VANE TYPE VACUUM PUMP W/REED  
TYPE EXHAUST VALVE  
MODEL 23-445 (55 CFM) SPECIAL SERVICE ROTARY VANE TYPE  
VACUUM PUMP W/REED TYPE EXHAUST VALVE  
23-5 LOT NO. 79070 TO  
23-445 LOT NO. 79071 TO**

SYM	PART NO.	DESCRIPTION	REF. DWG/ COMP. LIT.	QTY	UM	RSP
<b>NOTE FOR -444 PUMPS ONLY: When ordering parts for your Rotary Vane Pump, please specify that your pump is being used for Special Service</b>						
32	085-039-018	RUBBER BUMPER		4	EA	
33	427-272-003	FRONT PLATE		1	EA	
34	427-273-003	1ST STAGE STATOR		1	EA	
35	427-274-004	INTERSTATE PLATE		1	EA	
36	427-275-005	2ND STAGE STATOR		1	EA	
37	427-276-005	END PLATE		1	EA	
38	427-285-003	RESERVOIR		1	EA	
39	427-706-001	FAN - 6-1/2 DIA.		1	EA	
40	427-643-002	COUPLING (MOTOR DRIVE)		1	EA	
41	600-058-004	ROTOR, 1ST STAGE		1	EA	
42	600-059-004	ROTOR, 2ND STAGE		1	EA	
43	085-039-267	GEROTOR ASSEMBLY		1	EA	
44	429-926-002	GEROTOR COVER		1	EA	
45	427-717-006	SIDE COVER		2	EA	
46	429-639-001	OIL FILTER		1	EA	✓
47	427-725-001	OIL FILTER THREADED TUBE		1	EA	
48	427-636-001	INLET SCREEN ASSEMBLY		1	EA	
49	427-645-001	INLET FLANGE		1	EA	

RSP = RECOMMENDED SPARE PART  
UM = UNIT OF MEASURE

**MODEL 23-5 (55 CFM) ROTARY VANE TYPE VACUUM PUMP W/REED  
TYPE EXHAUST VALVE  
MODEL 23-445 (55 CFM) SPECIAL SERVICE ROTARY VANE TYPE  
VACUUM PUMP W/REED TYPE EXHAUST VALVE  
23-5 LOT NO. 79070 TO  
23-445 LOT NO. 79071 TO**

SYM	PART NO.	DESCRIPTION	REF. DWG/ COMP. LIT.	QTY	UM	RSP
NOTE FOR -444 PUMPS ONLY: When ordering parts for your Rotary Vane Pump, please specify that your pump is being used for Special Service						
50	428-224-001	EXHAUST FLANGE		1	EA	
51	427-734-004	EXHAUST VALVE COVER ASSEMBLY		1	EA	
52	428-116-001	GAS BALLAST VALVE CAP		1	EA	
53	428-117-001	GAS BALLAST VALVE BODY		1	EA	
54	428-226-001	GAS BALLAST TUBE		1	EA	
55	429-486-001	OIL TUBE		1	EA	
56	429-923-003	VALVE CAP		2	EA	
57	429-924-001	SPRING TUBE (GUIDE)		1	EA	
58	075-033-472	PLUG (FILL)		1	EA	
59	075-033-472	PLUG (DRAIN)		1	EA	
60	427-700-001	OIL SLINGER		1	EA	
61	085-037-922	SIGHT GLASS GAUGE, WINDOW TYPE		1	EA	
61A	085-039-900	SIGHT GLASS (POLYCARBONATE)		1	EA	
	601-868-001	REED VALVE BUSHING		1	EA	
	429-345-001	VALVE, EXHAUST CAM		3	EA	
	427-995-001	MOTOR KEY (NOT SHOWN)		1	EA	
	085-039-402	OIL, V-LUBE J	STANDARD SERVICE USE ONLY	1	GAL	✓

RSP = RECOMMENDED SPARE PART  
UM = UNIT OF MEASURE





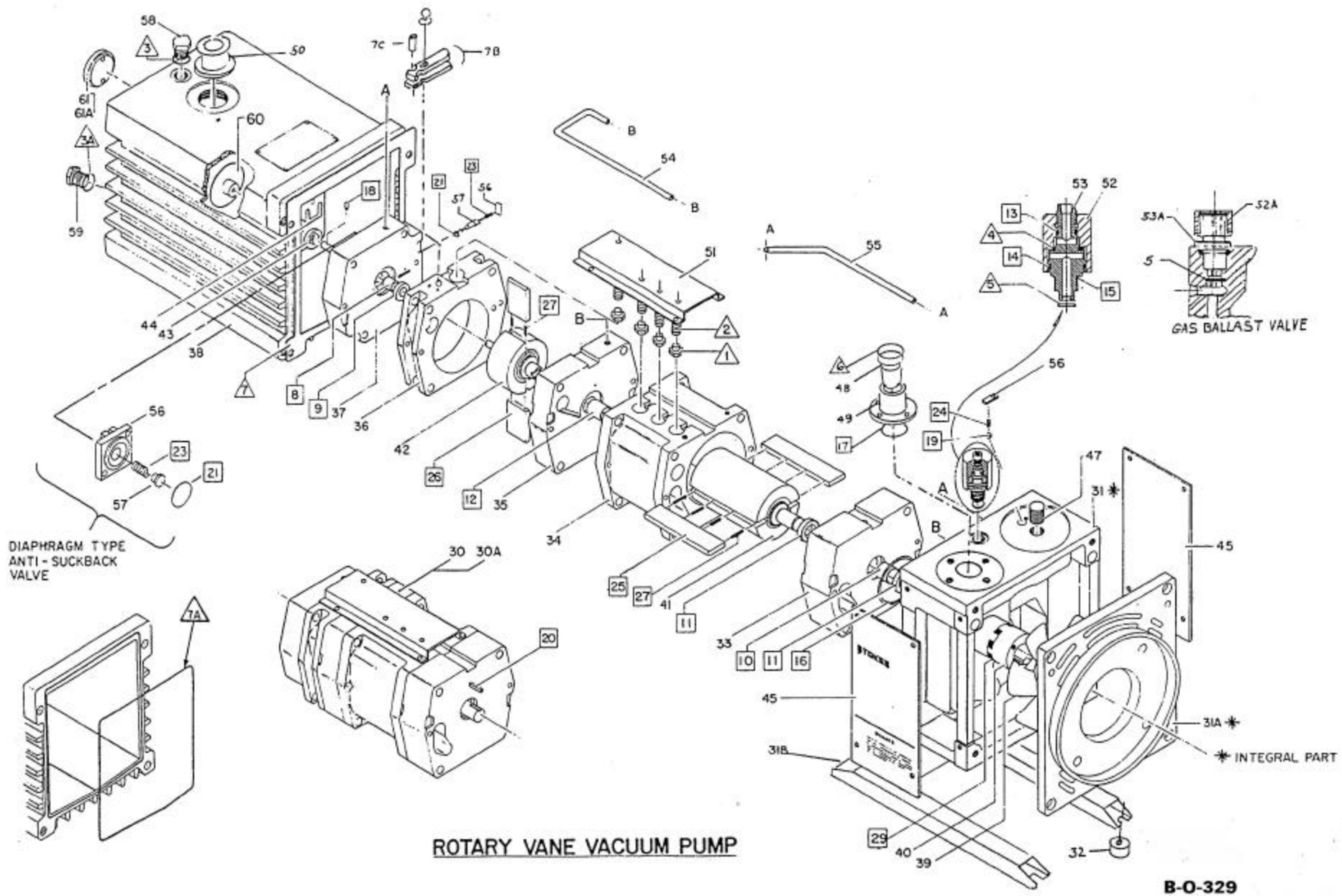

For **FAST** Part's Sales and Service  
for your Stokes Vacuum  
Equipment, call the office nearest  
you!!!

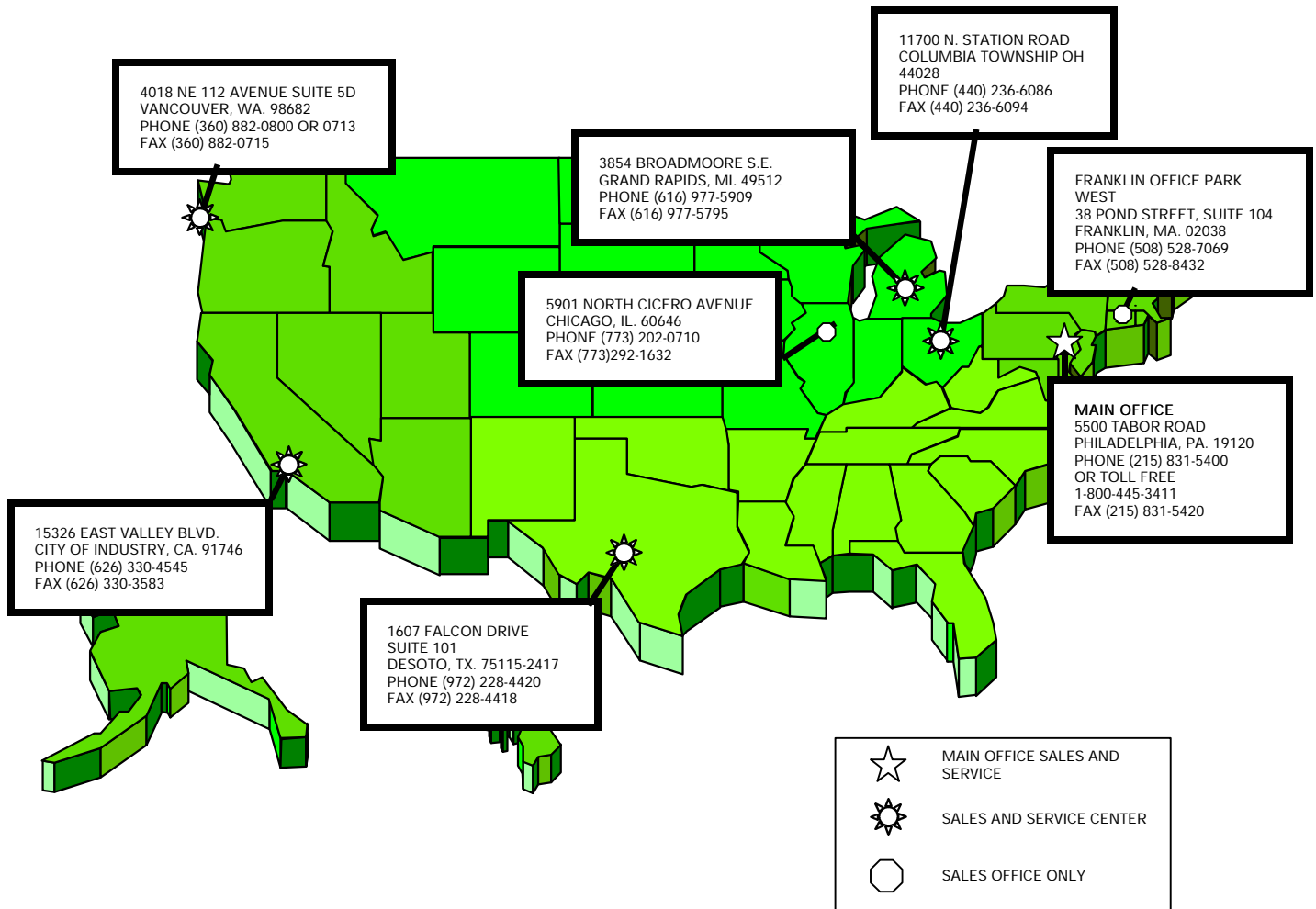

## PARTS ORDERING INFORMATION

The Stokes Customer Service Department is organized to assist you in keeping your equipment operating and to provide necessary parts as spares for your critical inventory as well as replacement parts as needed.

For faster service when ordering parts, please observe the following procedure:

- ✓ Order by part number shown on the parts list.
- ✓ Always include the model, lot and serial number of the equipment. These numbers can be found on the nameplate.
- ✓ Use the same nomenclature as shown on reference drawings and parts list. Also refer to drawing numbers and parts list symbol numbers whenever possible.
- ✓ When ordering electrical parts and solenoid operated valves, be sure to specify voltage, cycles and phase as well as the part number.

<http://www.stokesvacuum.com>

**For *FAST* Part's Sales and Service  
for your Stokes Vacuum  
Equipment, call the office nearest  
you!!!**

**FOR THE INTERNATIONAL SALES AND SERVICE CENTER  
NEAREST YOU PLEASE CALL 1-800-445-3411 AND ASK FOR  
OUR INTERNATIONAL CUSTOMER SERVICE DEPARTMENT.**

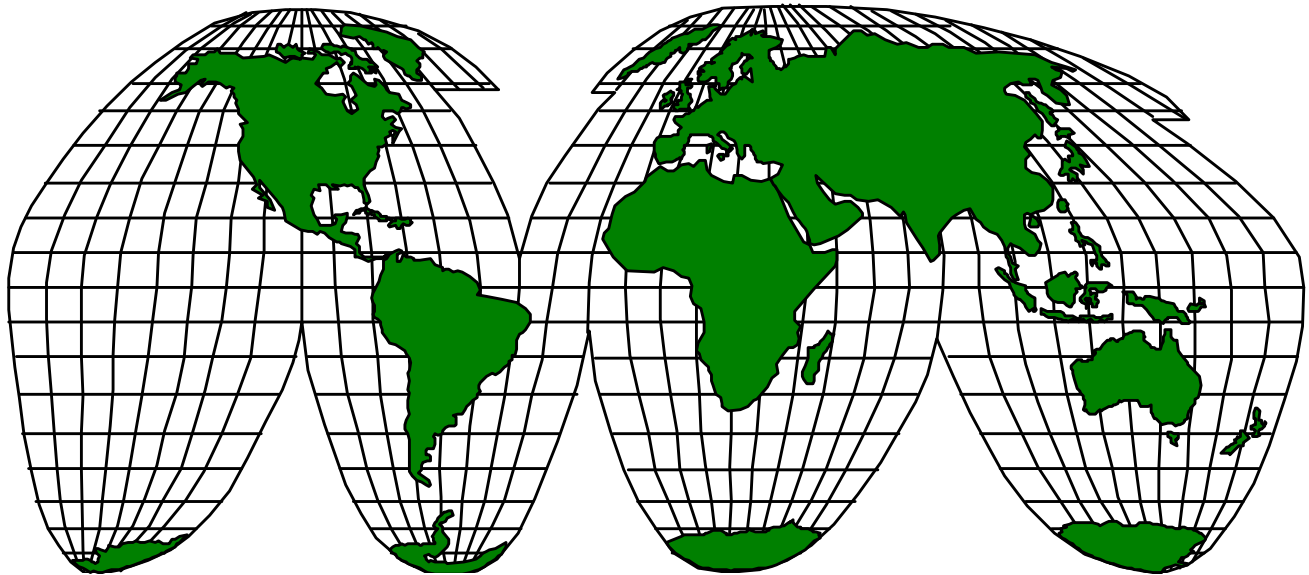

### **PARTS ORDERING INFORMATION**

The Stokes Customer Service Department is organized to assist you in keeping your equipment operating and to provide necessary parts as spares for your critical inventory as well as replacement parts as needed.

For faster service when ordering parts, please observe the following procedure:

- ✓ Order by part number shown on the parts list.
- ✓ Always include the model, lot and serial number of the equipment. These numbers can be found on the nameplate.
- ✓ Use the same nomenclature as shown on reference drawings and parts list. Also refer to drawing numbers and parts list symbol numbers whenever possible.
- ✓ When ordering electrical parts and solenoid operated valves, be sure to specify voltage, cycles and phase as well as the part number.



## PARTS ORDERING INFORMATION

The Stokes Customer Service Department is organized to assist you in keeping your equipment operating and to provide necessary parts as spares for your critical inventory as well as replacement parts as needed.

A wide range of critical and wear parts are stocked for your convenience. Special parts, not normally replaced, are not always stocked and Stokes is prepared to manufacture these on a priority basis.

In spite of our very effective Inventory Control System, unusual demands may find us out of stock on critical items and we strongly recommend that you carry an inventory of critical parts, as well as those special parts relative to your equipment. Wear items, those recommended for your inventory, are noted on the Parts List by an asterisk (\*). Having these parts readily available will assure maximum "Up-Time" for your equipment and minimum loss of production.

Those parts, marked by a plus sign (+) in the quantity column, are normally stocked in Philadelphia, with smaller quantities in our Service Centers around the country, (Dallas, Chicago, Los Angeles). If your parts list is not clear or seems to be incomplete, please contact the Stokes Customer Service Department, 5500 Tabor Road Philadelphia Pa. 19120, for an updated or clarified list.

For faster service when ordering parts, please observe the following procedure:

- 1) Order by part number shown on the parts list.
- 2) Always include the model, lot and serial number of the equipment. These numbers are listed in the instruction manual, on the parts list, and also stamped on the nameplate of the machine.
- 3) Use the same nomenclature as shown on reference drawings and parts list. Also refer to drawing numbers and parts list symbol numbers whenever possible.
- 4) When ordering electrical parts and solenoid-operated valves, be sure to specify voltage, cycles and phase as well as the part number.
- 5) For faster service send parts orders directly to Stokes Vacuum Inc., Customer Service Dept., 5500 Tabor Road, Philadelphia, Pa. 19120 or contact Customer Service Dept. at 1-800-445-3411.

## Warranty and Field Service Policy

### INTRODUCTION

The following describe Stokes warranty and service policies. These, in connection with the operating instructions attached, were produced for your benefit.

Maximum results can only be achieved if your technical staff thoroughly familiarizes itself with all features of Stokes equipment, many of which are unique. For this purpose Stokes will provide demonstration and instruction services whenever necessary and will gladly answer any questions that may arise.

Please read the following subject matter for further details of services that are available and provisions under which they can be supplied.

### DEMONSTRATION OF NEW EQUIPMENT

1. With certain Stokes equipment, demonstration service is included for the purpose of checking the installation and operation of the equipment. These services include one round trip from the factory or district service office and include traveling and living expenses. The specified time will be on the basis of an eight hour day (Monday through Friday), holidays excluded.
2. If additional demonstration services are required, a charge will be made for the additional time and expenses.
3. Stokes equipment is shipped with a normal amount of disassembly. It is the responsibility of the purchaser to provide suitable foundations and have the equipment fully assembled, and to have all wiring and piping completed in accordance with Stokes installation instructions before requesting demonstration. At least one week advance notice is requested in order to insure having qualified personnel available.
4. Stokes' responsibility extends only to the equipment it has supplied. In the event that ancillary or auxiliary items are added, the operation of these items by Stokes' Service Personnel will be at the Purchaser's risk.

### GENERAL SERVICE POLICY

1. Stokes provides the serviceperson, upon request, for the purpose of checking machines, recommending replacement parts, overhauling, rebuilding, etc. The customer will be charged for time and expense.
2. On courtesy calls, initiated by Stokes, minor adjustments will be made and instructions given free of charge. Should the customer request service beyond what might reasonably

- be defined as "major adjustments and instructions", a charge will be made for the additional time required. Should the request for additional service involve an unscheduled overnight stop-over or other unanticipated expense, the customer will also be billed for the added expenses involved.
3. Stokes servicepersons are specialists. Their primary functions are to demonstrate, to identify sources of trouble and to instruct customers' operating and maintenance personnel in methods of prevention and correction. To obtain maximum utilization of the servicepersons, customers should provide all necessary assistance in the form of movers, mechanics, operators, etc. Customers should also provide any standard tools and facilities that may be required and that cannot readily be carried by a serviceperson such as lifting equipment, electric drills, etc.

#### REBUILDING, REPAIRING AND MODIFYING STOKES EQUIPMENT

Customers interested in major overhaul and/or repair work on their existing machines should first consider the age and general condition of the equipment under consideration, the current cost of comparable new equipment and comparable design features. If it is deemed advisable to rebuild rather than replace, the equipment should be returned to the Stokes factory.

Pumps being rebuilt are thoroughly disassembled, cleaned and reassembled with new parts. The rebuilt pump is put on the test block and checked for performance. Only when acceptable performance is demonstrated, is the pump released for shipment.

Pumping units are available for rental, subject to availability, by customers who need additional pumping capacity for short periods or to fill in while the regular equipment is being repaired or rebuilt.

The cost of disassembling, cleaning and inspection is included in the price. The parts for the major repair kit used are included in the parts section of this manual. If the additional parts required or if repairs are found to be so extensive that rebuilding is considered uneconomical and the project is dropped, the customer will be invoiced a previously established fixed fee.

#### PUMPING HAZARDOUS GASES

Pumping certain gases or gaseous mixtures is hazardous. Consequently, we cannot assume responsibility for the operational safety of our pumping components. We can only alert you to this hazard and suggest procedures to minimize the possibility of an explosion.

1. The mechanical pump should be located in a safe area so that the reactive gas is unlikely to be present in the atmosphere surrounding the unit.

2. It is essential that the vacuum system, including discharge line, be free of air leaks, so that gases will not leak into or out of the system.
3. The pump should be purged with nitrogen (or other suitable inert gas) prior to, during and after operation. Purge port connections should be made at two locations: Port A - to be at the pump inlet on the pump side of the inlet line valve; Port B - to be in the discharge of the pump.

Port A (at inlet) is to be used with the inlet valve closed, but with the pump in operation. This will help reduce the percentage of reactive gas present in the unit and the discharge. When the inlet valve is open, Port A should be closed. After the evacuation is complete, the inlet valve should be closed and Port A reopened to purge the pump and to fill all voids in the pump and discharge line.

Port B (discharge) is to be used while the unit is in operation, with inlet valve open (but with Port A closed). This will assure a continuous positive flow of inert gas through the pump's discharge section to safely carry off the reactive gas being evacuated from the system. The inert gas flow must be sufficient to prevent exhaust gases from back diffusing through the exhaust line into the pump.

4. The discharge line from the vacuum pump should be vented to a suitable safe area outside of any building where it is unlikely that the reactive gas could accumulate. The work area around the pumping equipment should also be ventilated to avoid the possibility of reactive gas accumulations.
5. A suitable flame arrester should be placed in the discharge line. The discharge pipe should be marked to avoid the possibility of workmen welding, or working near the area with open flames or dangerously hot equipment.
6. While it is normally unlikely that the reactive gas will be present in the work area, insurance regulations in a given locality may require special electrical components. Where stricter electrical specifications are dictated, the main control panel for the pump(s) can be located outside the hazardous area with only the vacuum switch with its associated time delay and control relays located on the mechanical booster pump. These small electrical components do not require a very large housing and can be assembled directly on the pump in a safe enclosure. The various motor and control leads can then be fed to the pumps from a safe remote location.



# STOKES EQUIPMENT WARRANTY

PRODUCT	MICROVAC PUMP	VACUUM BLOWER	MICROVANE PUMP	DRY PUMP
NUMBER OF WARRANTY YEARS	TWO YEAR	TWO YEAR	ONE YEAR	ONE YEAR
PARTS CONSIDERED EXPENDABLE	EXHAUST VALVE AND GAS BALLAST SPRINGS; SOLENOID VALVE COIL; SHAFT SEALS; "V" BELTS; GASKETS.	"O" RINGS; SHAFT SEALS	SOLENOID VALVE COIL; SHAFT SEALS; GASKETS; "O" RINGS, SHAFT SLEEVE, VALVE SPRINGS, EXHAUST VALVES, VANES	SOLENOID VALVE COIL; SHAFT SEALS; GASKETS; "O" RINGS, SHAFT SLEEVE

Stokes Vacuum Inc warrants every Stokes product against defects in material and workmanship for a period stated above (number of warranty years) from the date of shipment, as described in our "Condition of Sale."

Every part is covered by the warranty except normally replaceable parts that are considered expendable; their life expectancy being determined by the type of service to which the pump is subjected. However, repair or replacement of any part will be made F.O.B. seller or supplier's plant, if the part in question was defective at the time of delivery.

Stokes Vacuum Inc will honor this warranty for the period stated above (number of warranty years) from the date of shipment, when the user demonstrates that the following basic conditions have been met:

- ❑ The equipment must be properly installed and operated in accordance with the established procedures outline in the Instruction Manual supplied with the equipment.
- ❑ The equipment must be protected to prevent dirt, foreign materials and corrosive vapors from entering the intake and causing damage to the working parts.
- ❑ Service the equipment at proper intervals consistent with its usage. Use the proper grade and quality of recommended oil. Stokes "V" Lube is available in several grades to assure you of meeting the latter requirements.
- ❑ Follow preventive maintenance schedule as outlined in the Operating Instruction Manual.

Our Engineering-Advisory Services are available, at no charge, to assist the user and to insure that the user obtains the maximum performance and operating life from the "tried and proven" Stokes Vacuum Equipment. Use this service for advice regarding special or unusual applications of your equipment.



# Quality Survey

**Thank you** for purchasing your equipment from Stokes Vacuum Inc. In our pursuit of complete customer satisfaction we would appreciate your comments on the usefulness and readability of this manual. Please fax (215) 831-5420 or mail this sheet to Stokes Vacuum Inc 5500 Tabor Road, Philadelphia, PA. 19120 Attn: Technical Publications Department. Your cooperation is greatly appreciated.

Thank you again,

Robert J. Landis  
Manager, Technical Publications

Stokes Model Number \_\_\_\_\_ Stokes Order Number \_\_\_\_\_

Revision Date of Manual \_\_\_\_\_

Please Rate the Following Items

**Compared to similar manuals, this manual is...**     **Good**     **Fair**     **Poor**

**Ease of reading is ...**     **Good**     **Fair**     **Poor**

**Level of information is ...**     **Good**     **Fair**     **Poor**

**Photographs and/or Illustrations are ...**     **Good**     **Fair**     **Poor**

**The amount of information was ...**     **Good**     **Fair**     **Poor**

**Comments?**

---

---

---

---

---