

# CHAIN SAWS

MONTGOMERY  
**WARD**

## owner's guide

and PARTS LIST

MODEL NO.

TMY-24066B

TMY-24068B

FORM NO. 89-SAW-3B\*

*BAR # McCulloch  
026-MC 214236*

TMY-24066B

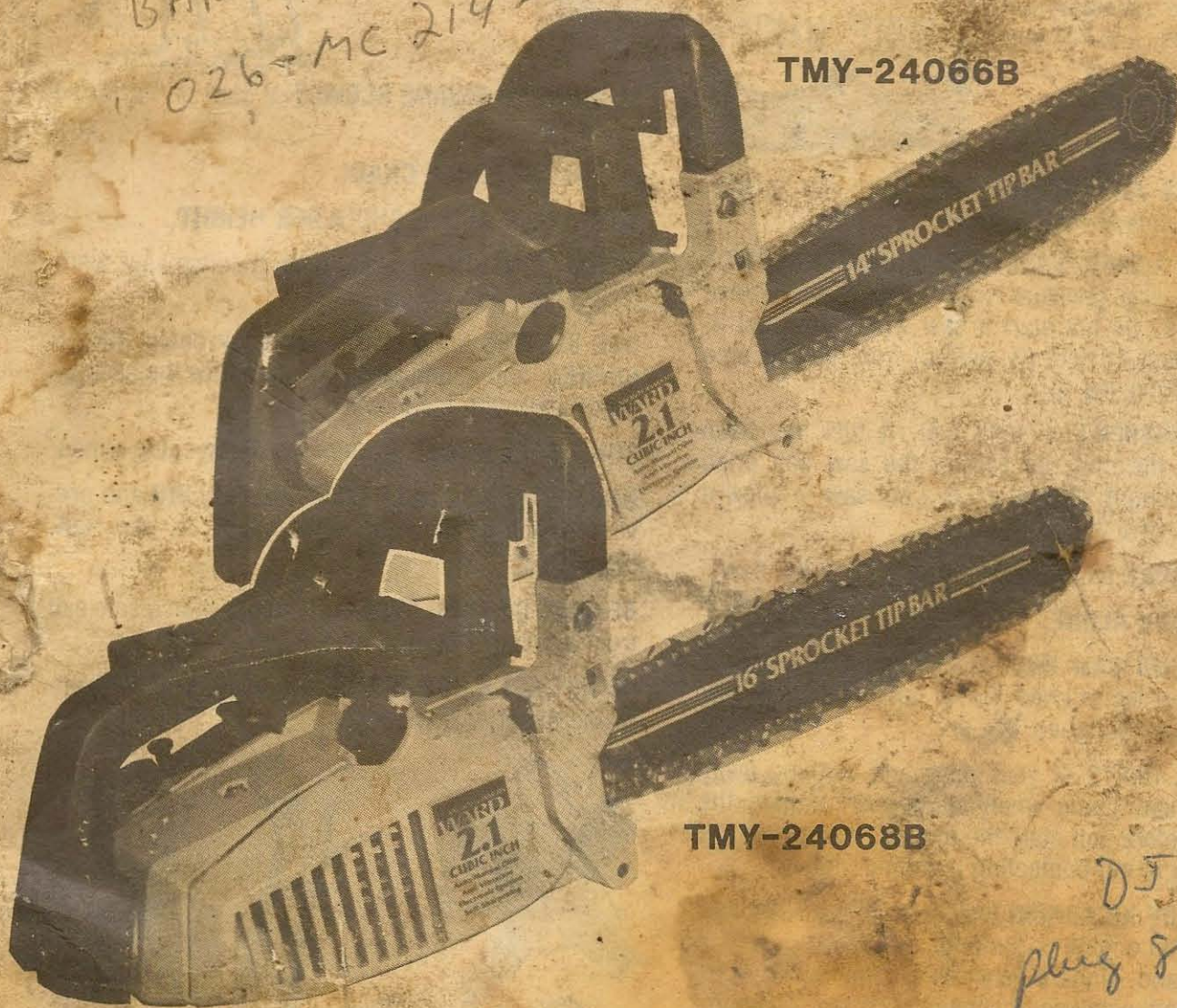

TMY-24068B

*DJ85  
plug saw  
25 thousandth*

READ THIS OWNER'S GUIDE COMPLETELY BEFORE OPERATING SAW.

## SAFETY INSTRUCTIONS

**READ YOUR OWNER'S GUIDE AND ALL SUPPLEMENTS** (if any enclosed) thoroughly before operating your saw. (Fig. 1)

Operation of a chain saw should be restricted to mature, properly instructed individuals. **DO NOT ATTEMPT OPERATIONS BEYOND YOUR CAPACITY OR EXPERIENCE.**

**WEAR CLOSE FITTING AND PROTECTIVE WORK CLOTHING** that is made to give protection, such as (A) safety hat, (B) safety shield, safety goggles or safety glasses, (C) safety work shoes, (D) heavy duty work gloves, and (E) good grade ear plugs or sound barriers. (Fig. 2)



**DON'T USE ANY OTHER FUEL** than that recommended in this Owner's Guide.

**REFUEL IN A SAFE PLACE. OPEN FUEL CAP SLOWLY** to release any pressure which may have formed in fuel tank. Do not start a saw where you fuel it, move at least 10 feet (3 meters) from fueling area before starting. (Fig. 3)

**DO NOT OVERFILL** or spill fuel. If fuel has been spilled on the unit, be certain the saw has dried before starting it. Do not refuel a hot saw — allow it to cool off. (Fig. 3)

**DON'T SMOKE** while fueling or operating the saw.

**DON'T WORK ALONE.**

(Fig. 4)

**START YOUR SAW WITHOUT HELP.** Don't start a saw on your leg or knee. Never operate a chain saw when you are fatigued. (Fig. 5)

**KEEP ALL PARTS** of your body and clothing away from the saw chain when starting or running the engine. Before you start the engine, make sure the saw chain is not contacting anything. (Fig. 6)

**BEWARE OF KICKBACK!** Hold saw firmly with both hands when engine is running; use a firm grip with thumbs and fingers encircling the chain saw handles and watch carefully what you cut. Kickback (saw jumps or jerks, up or backward) can be caused by:

- **STRIKING LIMBS** or other objects accidentally with the tip of the saw while the chain is moving.
- **STRIKING METAL**, cement, or other hard material near the wood, or buried in the wood.

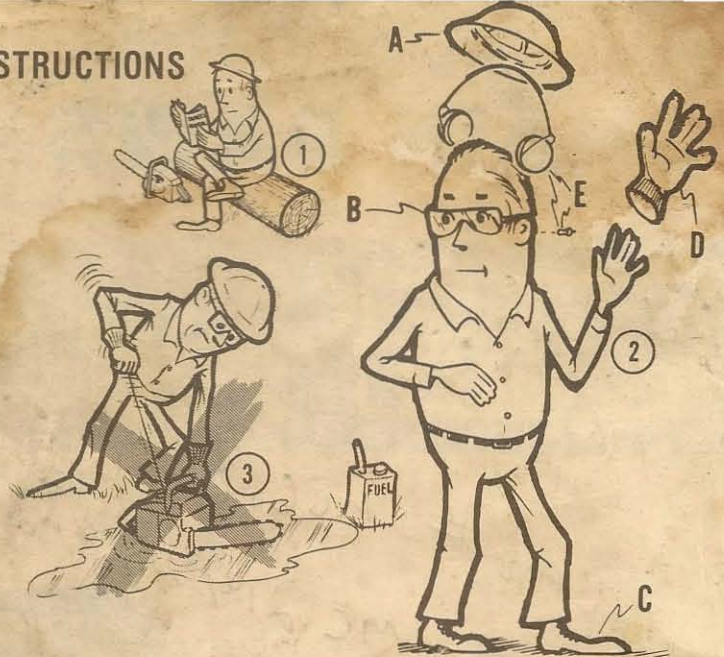

- **RUNNING ENGINE SLOWLY** at start of, or during cut.
- **DULL** or **LOOSE CHAIN.**
- **CUTTING ABOVE SHOULDER HEIGHT.**
- **INATTENTION** in holding or guiding saw while cutting.

**USE DEVICES** such as low kickback chain, **CHAIN BRAKES**, and handguards which reduce the hazards associated with kickback.

**DON'T FELL A TREE** during high or changing winds.

**USE WEDGES TO HELP CONTROL FELLING** and prevent binding the bar and chain in the cut. (Fig. 7)

**BE SURE OF YOUR FOOTING** and pre-plan a safe exit from a falling tree or limbs. (Fig. 7)

**DO NOT SET A HOT SAW DOWN** in areas where flammable material is present.



**WE STRONGLY RECOMMEND** you do not attempt to operate the saw while **IN A TREE, ON A LADDER or ON ANY OTHER UNSTABLE SURFACE.** If you elect to do so, be advised that these positions are **EXTREMELY DANGEROUS.** (Fig. 8)

**DON'T CUT IN AWKWARD POSITIONS** (off-balance, out-stretched arms, one-handed, etc.).

**WHEN CUTTING A LIMB THAT IS UNDER TENSION** be alert for springback so that you will not be struck when the tension is released. (Fig. 9)

**USE EXTREME CAUTION** when cutting small size brush and saplings because slender material may catch the saw chain and be whipped toward you, or pull you off balance. (Fig. 9)

**VIBRATION** — Avoid prolonged operation of your chain saw and rest periodically, especially if your hands or arms start to have a loss of feeling, swell or become difficult to move. These conditions can

reduce your ability to control a saw.

**EXHAUST FUMES** — Do not operate your chain saw in confined or poorly vented areas.

**OBSERVE ALL LOCAL FIRE PREVENTION REGULATIONS.** We recommend that you keep a fire extinguisher and shovel close at hand whenever you cut in areas where dry grass, leaves or other flammable materials are present.

**NOTE:** Your chain saw is equipped with a spark arrester screen which meets all current standards for spark emissions. The spark arrester screen must be inspected daily to ensure that it has not become plugged or damaged. Check local fire regulations for your special requirements.

**NEVER OPERATE YOUR CHAIN SAW WITHOUT A MUFFLER.**

**DO NOT CARRY THE SAW BY THE CHAIN BRAKE LEVER.**

**WHEN TRANSPORTING YOUR CHAIN SAW,** use the appropriate guide bar scabbard.

**TURN OFF YOUR SAW WHEN MOVING BETWEEN CUTS** and before setting it down. Always carry the chain saw with the engine stopped, the guide bar and saw chain to the rear, and the muffler away from your body. (Fig. 10)

**DON'T TOUCH** or try to stop a moving chain with your hand. (Fig. 11)

**DON'T ALLOW ANY OTHER PERSON or ANIMAL CLOSE** to a running saw or where a tree is being cut down. (Fig. 12)

**DON'T TOUCH** or let your hand come in contact with a hot muffler, spark arrester, or a spark plug wire. Don't run the saw without a muffler, exhaust stack, or a spark arrester. Keep screens and baffles clean. (Fig. 13)

**KEEP THE CHAIN SHARP and SNUG** on the **GUIDE** bar. (Fig. 14)

**DON'T ALLOW DIRT, FUEL or SAWDUST** to build up on the engine or outside of the saw.

**KEEP ALL SCREWS and FASTENERS TIGHT.** Never operate a chain saw that is damaged, improperly adjusted, or is not completely and securely assembled. Be sure that the saw chain stops moving when the throttle control trigger is released. Keep the handles dry, clean and free of oil or fuel mixture. (Fig. 15)

**DON'T OPERATE YOUR CHAIN SAW** unless the chain stops when the engine idles. (Have corrected.)



# GENERAL CUTTING INSTRUCTIONS

Before using your saw, you should review the safety precautions listed in your Owner's Guide, and all local regulations for the operation of your saw. These precautions and regulations are for your protection.

For all types of cutting, always hold saw firmly with both hands, with thumbs and fingers encircling saw handles.

Cut at high engine speeds (full throttle) only. Don't run the engine slowly at the start or during the cut.

Pre-plan a safe exit from a falling tree or limbs.

Cut wood only.

Test the operation of the CHAIN BRAKE before cutting.

## FELLING

Direction of fall is controlled by the undercut. Type "A" is easy to make and is commonly used for small trees. Type "B" leaves butt end of log cut squarely across. Type "C" is a variation of Type "A". The notch should be about 1/3 diameter of the tree. On felling cut, do not cut through to notch. Uncut band of wood parallel to notch serves as a hinge. Make cuts in order shown — 1, 2, 3 on "A". (Fig. 16)

When diameter of wood being cut is greater than bar length, make two cuts as shown. (Fig. 17)

## BUCKING

When bucking on a slope, always stand on the up hill side.

**LOG SUPPORTED ALONG ENTIRE LENGTH:** Cut from top (overbuck), being careful to avoid cutting earth. (Fig. 18)

**LOG SUPPORTED ON ONE END:** First cut from bottom (underbuck) 1/3 diameter of log to avoid splintering. Second, overbuck to meet first cut and avoid pinching. (Fig. 19)

**LOG SUPPORTED ON BOTH ENDS:** First overbuck 1/3 diameter of log to avoid splintering. Second, underbuck to meet first cut and avoid pinching. (Fig. 20)

## LIMBING

Keep the log off the ground. Do not remove supporting limbs until after the log is bucked into lengths. (Fig. 21)

This consumer chain saw is intended for general homeowner use, and such general applications as clearing, pruning, and cutting firewood.

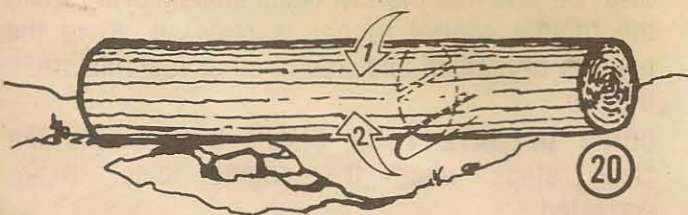
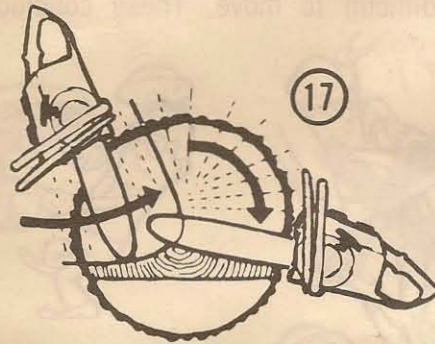
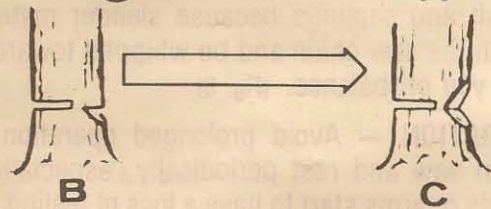
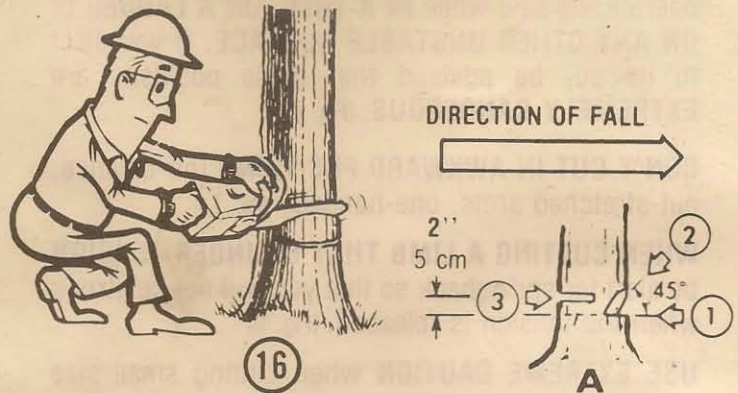

# TABLE OF CONTENTS

SAFETY INSTRUCTIONS ..... 2

GENERAL CUTTING INSTRUCTIONS ..... 4

IDENTIFICATION ..... 5

FUEL AND LUBRICATION ..... 6

    Fuel

    Fuel Mixture Table

    Mixing Fuel

    Chain and Bar Lubrication

INSTALLATION INSTRUCTIONS ..... 6

    Guide Bar, Saw Chain and CHAIN BRAKE

    QUIK-SHARP Installation

OPERATING INSTRUCTIONS ..... 9

    CHAIN BRAKE Operation

    Starting and Stopping

    Carburetor Adjustment

    QUIK-SHARP Operation

    Breaking in a New Engine

    Storing a Chain Saw

    Removal from Storage

MAINTENANCE ..... 13

    Spark Plug

    Fuel Cap Vent

    Fuel Tank Filter

    Air Filter

    Starter Cover and Cooling Fins

    Muffler and Exhaust Port

    CHAIN BRAKE Maintenance

    Sprocket, Clutch, and Clutch Drum

    Automatic Oiler Adjustment

    Guide Bar Maintenance

CHAIN MAINTENANCE ..... 17

    Chain Tension

    New Chain Break-In

    Chain Lubrication

    Chain Sharpening

    Lowering Depth Gauges

    Touch Up Hand Filing

    QUIK-SHARP Grinding Stone

PREVENTIVE MAINTENANCE ..... 20

FEATURES AND SPECIFICATIONS ..... 20

ACCESSORIES ..... 21

    Carrying Case

    Chain, Bar and Sprocket Oil

PARTS LIST AND DIAGRAM ..... 22

# IDENTIFICATION

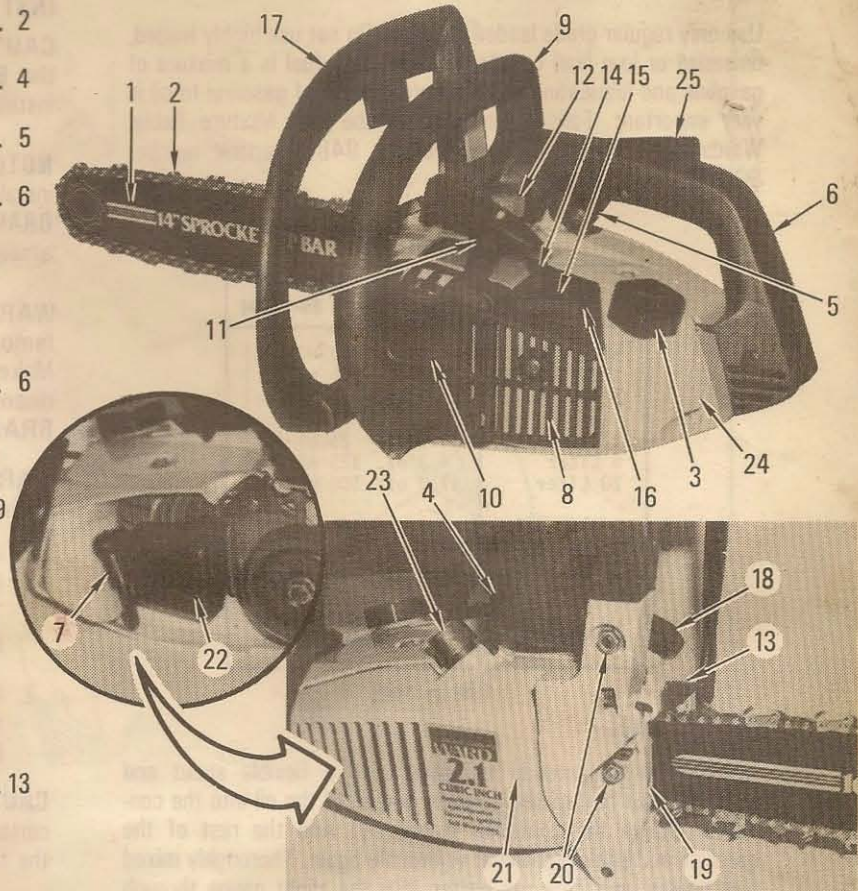

- |                          |  |
|--------------------------|--|
| 1. Guide Bar             | 14. Throttle Latch Knob                |
| 2. Saw Chain             | 15. Carburetor Controls                |
| 3. Fuel Tank Cap         | 16. Choke Knob                         |
| 4. Manual Oiler Knob     | 17. CHAIN BRAKE Lever/Handguard        |
| 5. Throttle Trigger      | 18. Oil Tank Cap                       |
| 6. Rear Handle           | 19. Saw Chain Tension Adjustment Screw |
| 7. Spark Plug Cover      | 20. CHAIN BRAKE Retaining Nuts         |
| 8. Air Cleaner Cover     | 21. CHAIN BRAKE                        |
| 9. Front Handle          | 22. Muffler                            |
| 10. Starter Cover        | 23. QUIK-SHARP (TMY-24068B)            |
| 11. Starter Handle       | 24. Fan Housing                        |
| 12. Ignition/Stop Switch | 25. Safety Trigger                     |
| 13. Spike (TMY-24068B)   |  |

**NOTE:** Many threaded fasteners on your saw are metric. For replacement see your Wards Service Center to obtain correct metric or American standard sizes. Metric tools can be used on these fasteners in many cases, so tool sizes are shown in both metric and American standard.

The model number and serial number are stamped on the model plate attached to the bottom of the saw. You should record these numbers for future reference in the space provided.

Model Number:
Serial Number:

## FUEL AND LUBRICATION

### FUEL

Use only regular grade leaded gasoline. Do not use highly leaded, unleaded or low lead gasolines. Chain saw fuel is a mixture of gasoline and lubricating oil. The correct ratio of gasoline to oil is very important. Follow the ratios in the Fuel Mixture Table. Wards 40:1 Engine Oil, part number 94884 article number 89-24194, is recommended.

FUEL MIXTURE TABLE

Gasoline	Wards 40:1 Engine Oil Article Number 89-24194
½ U.S. Gal.	1.6 oz. 48 ml (cc)
1 U.S. Gal.	3.2 oz. 95 ml (cc)
5 U.S. Gal.	16.0 oz. 475 ml (cc)
1 Liter	0.9 oz. 25 ml (cc)
5 Liter	4.3 oz. 125 ml (cc)
20 Liter	17.0 oz. 500 ml (cc)
1 Imp. Gal.	4.3 oz. 125 ml (cc)
2 Imp. Gal.	8.6 oz. 250 ml (cc)
5 Imp. Gal.	21.4 oz. 625 ml (cc)
<b>Mixing Ratio</b>	<b>40 parts gasoline to 1 part lubricant</b>

1 ml = 1cc

### MIXING FUEL

Mix fuel in a container equipped with a flexible spout and strainer. Pour half of the gasoline and all of the oil into the container. Shake the container vigorously! Add the rest of the gasoline and shake container vigorously again. Thoroughly mixed fuel makes your saw run better. Use the slight gauge through the fan housing for determining your fuel supply.

**CAUTION:** Fuel additives or special starting fluids should not be used because seals and other rubber composition parts may be damaged.

### CHAIN AND BAR LUBRICATION

Always refill the chain oil tank each time the fuel tank is refilled. We recommend using Wards Chain, Bar and Sprocket Oil, part number 94886, article number 89-24195, which contains additives to reduce friction and wear and to assist in the prevention of pitch formation on the bar and chain. If Wards Chain, Bar and Sprocket Oil is not available, use SAE 30 non-additive motor oil at temperatures above 40°F (5°C) and SAE 10 non-additive motor oil at lower temperatures.

## INSTALLATION INSTRUCTIONS

### GUIDE BAR, SAW CHAIN AND CHAIN BRAKE INSTALLATION

**CAUTION:** Do not attempt to start or run the engine until the **BAR, SAW CHAIN** and **CHAIN BRAKE** have been installed.

**NOTE:** **QUIK-SHARP** must be removed from the saw before installing or removing the **BAR, SAW CHAIN** and **CHAIN BRAKE**. This is necessary only when the **QUIK-SHARP** is assembled on the unit (TMY-24068B).

**WARNING:** Handle the **CHAIN BRAKE** carefully when it is removed from the saw because the lever is under tension. Make certain the **CHAIN BRAKE** lever is pulled back to the disengaged position when installing or removing the **CHAIN BRAKE**.

**WARNING:** Always wear protective gloves when handling chain.

1. Remove the upper retaining nut and bolt, and the lower retaining nut. Remove the **CHAIN BRAKE**. This is only necessary when the **CHAIN BRAKE** is assembled on the unit. (Fig. 22)
2. Place the bar pad spacer over the bar bolt and onto the bar pad. If a spike is to be used, **DO NOT** use the bar pad spacer. (Fig. 23)

**CAUTION:** When installing the bar pad spacer or spike, be certain the chain oil slot is at the top so that chain oil can enter the top oil passage in the guide bar. (Fig. 23)

3. When using a spike, place it over the bar bolt and ensure a snug fit against the bar pad. (Fig. 23)

**CAUTION:** You must use a bar pad spacer or spike but not both; this will ensure correct alignment of the sprocket and bar. (Fig. 23)

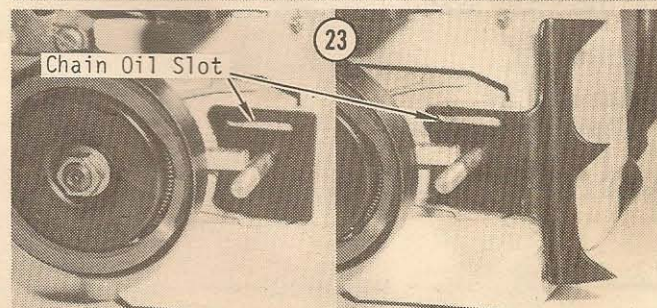
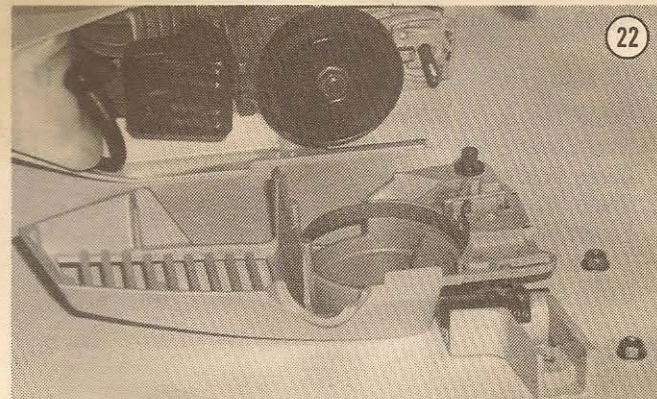

4. Slide the slotted end of the bar over the bar mounting bolt and push it back toward the sprocket as far as it will go. (Fig. 24)
5. Spread the chain out in a loop with the cutting edges of the chain pointing clockwise around the loop. (Fig. 25)
6. Tilt the top of the chain away from you so that you can slide it edgewise over the top of the drum (under the saw housing and bracket). (Fig. 26)
7. Guide the chain around and behind the drum (between the drum and the muffler) and onto the sprocket. (Fig. 27)
8. Move the chain back and forth to make sure it is in proper mesh with the sprocket and lined up with the bar groove. (Fig. 27)
9. Guide the chain center links into the bar groove all the way around the bar. Pull the nose of the bar out to take up all the slack in the chain. (Fig. 28)
10. Make certain the **CHAIN BRAKE** lever is pulled back to the disengaged position (chain can move). (Fig. 29)
11. Install the **CHAIN BRAKE**, being certain the ridge at the bottom rear of the brake housing is positioned between the fuel tank and the spark plug wire, the brake band is fitted carefully around the outside of the clutch drum, and the **CHAIN BRAKE** lever is set properly onto the **CHAIN BRAKE**. (Figs. 30, 31)

**CAUTION: THE CHAIN BRAKE CAN BE CRACKED OR BROKEN** if carelessly installed. The chain tension adjustment nut (tang) must be properly positioned in the adjustment hole in the bar before tightening the lower retaining nut. There should be no large gaps between the **CHAIN BRAKE** and the saw housing, and the front should fit snug against the bar. (Fig. 31)

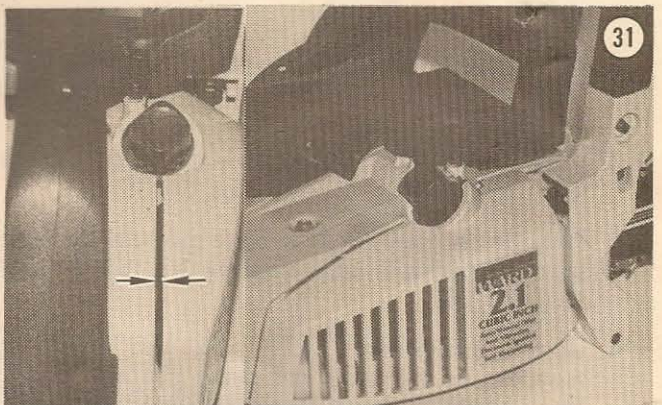
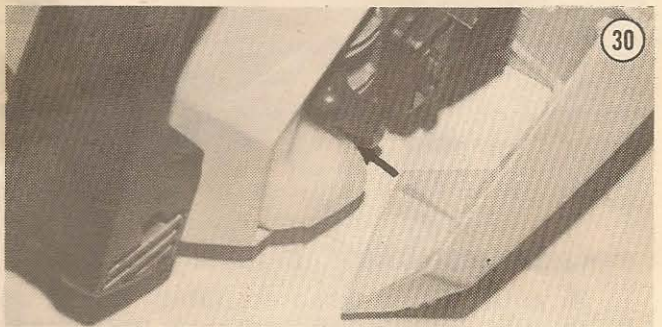
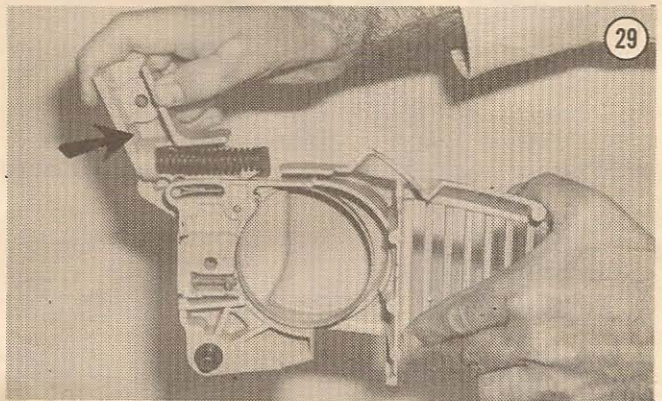
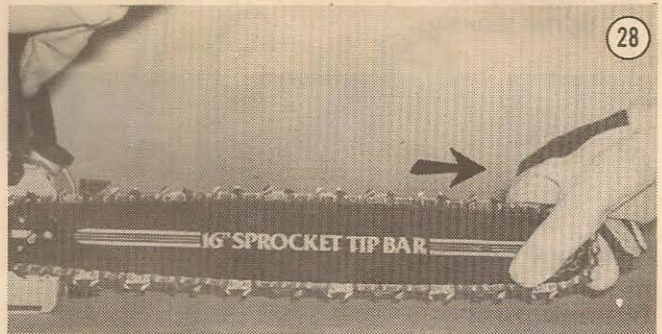
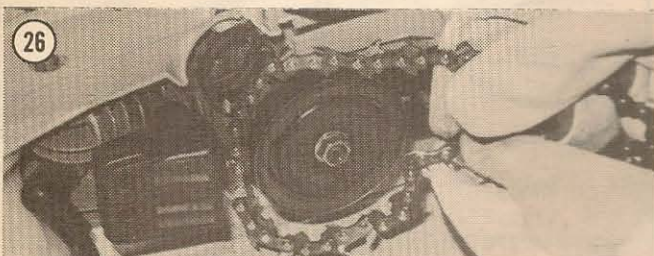
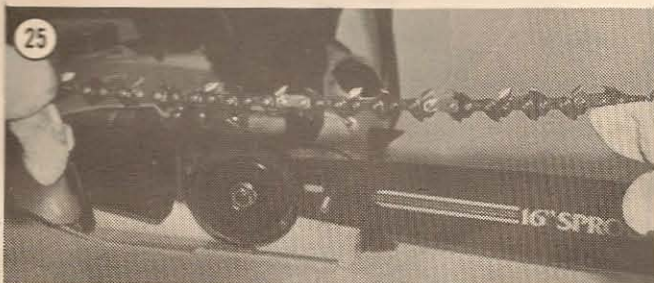
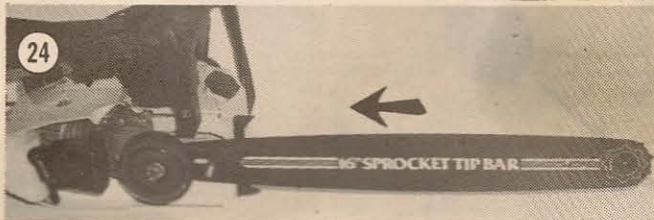

12. Turn the chain tension adjustment screw in or out to align the nut with the bar hole. (Fig. 32)
13. Install the lower retaining nut finger tight.
14. Hold the nose of the bar up and turn the adjustment screw clockwise to tension the chain. It should be a snug fit all around the bar. (Fig. 33)
15. Holding the nose of the bar up, tighten the lower retaining nut securely.
16. Install the retaining bolt and nut to the brake lever and tighten securely.

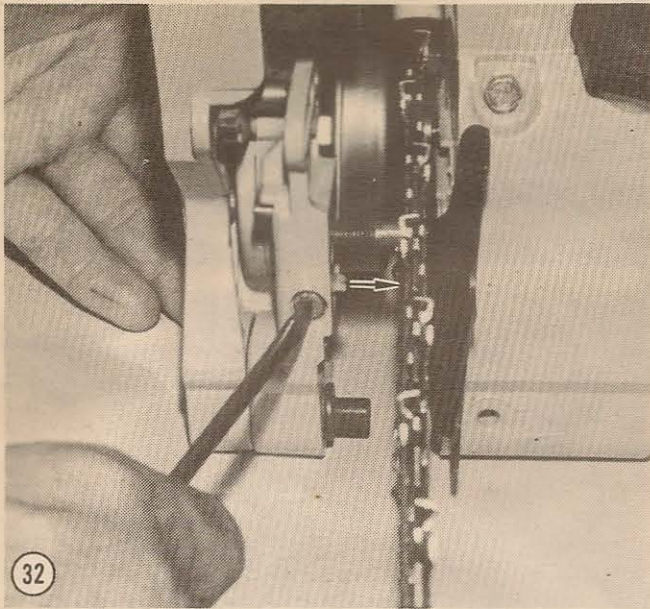

#### QUIK-SHARP INSTALLATION (TMY-24068B)

1. Be certain the bar, chain and **CHAIN BRAKE** are correctly installed before installing the **QUIK-SHARP** assembly.
2. Remove the **QUIK-SHARP** assembly from its package. Rotate the knob clockwise until it separates from the body. (Fig. 34)
3. Align the ears on the assembly with the slots in the mounting bracket on the unit. (Figs. 34, 35)
4. Push the assembly firmly in place and turn the entire assembly clockwise approximately 1/4 turn or until snug. (Fig. 36)
5. Using a screwdriver, place in notch and engage the serrations on the body and gently continue turning the assembly clockwise approximately 1.6 to 2.4 mm

(1/16 to 3/32 inch) until fully engaged. **DO NOT APPLY TOO MUCH FORCE.** (Fig. 37)

6. Place the two hooked ends of the bail in two serrations, exactly opposite one another, also ensuring they are set through the bracket. (Fig. 38)
7. Holding the looped portion of the bail, swing it up and over the body. (Fig. 38)
8. Snap the bail over the side of the body into its final position. (Fig. 39)
9. To attach the knob onto the body, engage the ratchet teeth, depress the knob and turn counterclockwise a few turns until the knob and body "catch". Now, gently continue turning the knob until it will no longer turn; you are now ready to use the **QUIK-SHARP**.

**DO NOT FORCE THE KNOB BEYOND THIS POINT.**

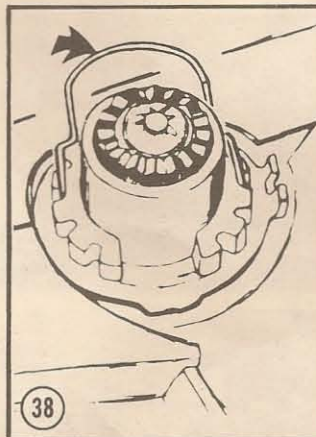
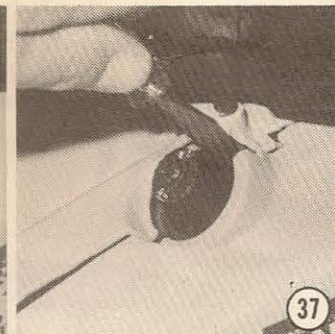
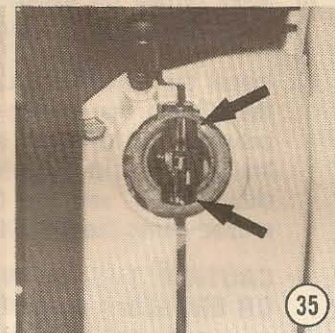
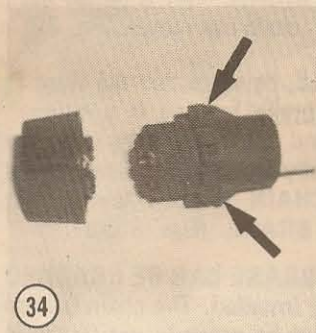

# OPERATING INSTRUCTIONS

## CHAIN BRAKE OPERATION

Your chain saw is equipped with a **CHAIN BRAKE** that reduces the possibility of injury due to "kickback." The brake is actuated if pressure is applied against the brake lever when, as in the event of "kickback," the operator's hand strikes the lever. When the brake is actuated, chain movement stops abruptly.

**CAUTION:** Purpose of the **CHAIN BRAKE** is to reduce the possibility of injury due to "kickback" but it cannot provide the measure of protection intended if the saw is operated carelessly.

The **CHAIN BRAKE** is disengaged (the chain can move) when the brake lever is pulled back and locked. (Fig. 40)

The **CHAIN BRAKE** is engaged (chain is stopped) when the brake lever is in the forward position. (Fig. 41)



When the brake lever has been tripped, the chain stops. Immediately release the throttle trigger to prevent damage to engine or clutch.

If the **CHAIN BRAKE** has been actuated and the engine is idling, grasp the brake lever firmly and pull back to the locked position while controlling the saw with a hand grasping the rear handle. Be careful not to squeeze the throttle trigger.

**NOTE:** Do not attempt to start or operate the engine with the brake engaged (chain is stopped). Do not allow the engine to idle for long periods of time when the brake is engaged as this tends to build up heat in the sprocket bearing.

Before cutting with your saw, test the **CHAIN BRAKE** as follows:

1. Place the saw on a clear, firm and flat surface.
2. Follow the correct procedures to start the engine.
3. Grasp the rear handle firmly with the right hand. (Fig. 42)
4. With the left hand, hold the front handle (not the **CHAIN BRAKE** lever) firmly. (Fig. 42)
5. Squeeze the throttle trigger so that the chain begins to move, then activate (push forward) the **CHAIN BRAKE** lever. (Fig. 42)

**CAUTION:** Activate the **CHAIN BRAKE** SLOWLY

and **DELIBERATELY**. Be careful to keep chain from touching surface: don't let saw tip forward.

6. The chain should stop abruptly. When it does, release the throttle trigger immediately.

**NOTE:** If the chain does not stop, turn off the engine and check to be sure the **CHAIN BRAKE** is properly installed. If the installation is correct, take the saw to your Wards Service Center for repair or replacement of the **CHAIN BRAKE** assembly.

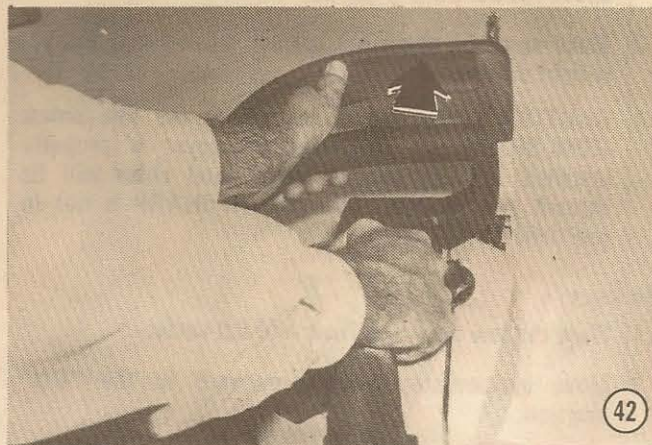

The **CHAIN BRAKE** lever/handguard provides the best protection against kickback when the saw is held at the top of the front handle. As the left hand moves around the front handle (toward the bottom of the saw) the **CHAIN BRAKE** requires increasingly more force to activate. However, the **CHAIN BRAKE** lever will act as a hand-guard if the saw is being held at any point on the front handle. (Figs. 43, 44)

**DO NOT HOLD THE SAW BY THE CHAIN BRAKE LEVER.**



## STARTING AND STOPPING

### Pre-Start Checks

1. Fill the fuel tank with correct fuel mixture. Be certain not to spill fuel on the saw and, if you do, allow saw to dry out thoroughly before attempting to start or operate.
2. Fill the chain oil tank with the correct chain oil and pump manual oiler until oil is seen at top of bar, above the bar bolt. (Figs. 45, 46)
3. Make sure the chain has correct tension and the bar is tight on saw.
4. **CAUTION:** Never start or operate the saw unless **QUIK-SHARP** or **QUIK-SHARP** cover is properly installed because sawdust and wood chips will be thrown out of the hole if **QUIK-SHARP** is not in position.

### To Start

1. Place the saw on a clear, firm and flat surface.
2. Move ignition/stop switch rearward to the "ON" position.
3. Pull the choke knob out (cold engine only).
4. Depress the safety trigger with the palm of your hand. Squeeze throttle trigger and lock the throttle latch by pulling the knob up and then releasing the throttle trigger. (Fig. 47)
5. Release trigger.
6. Grip the front handle firmly. (Fig. 48)

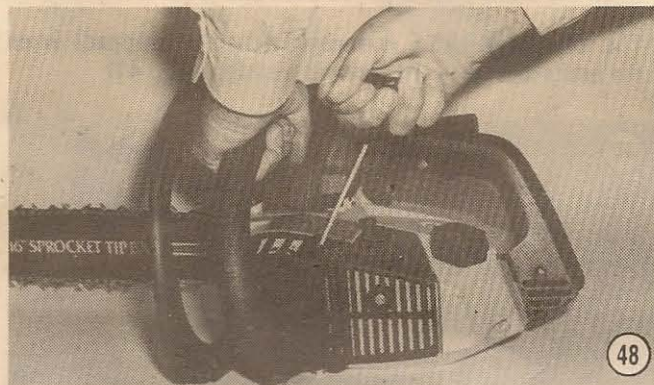
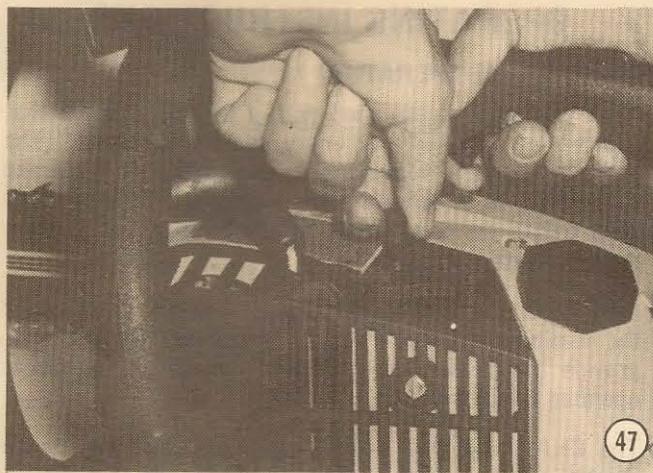
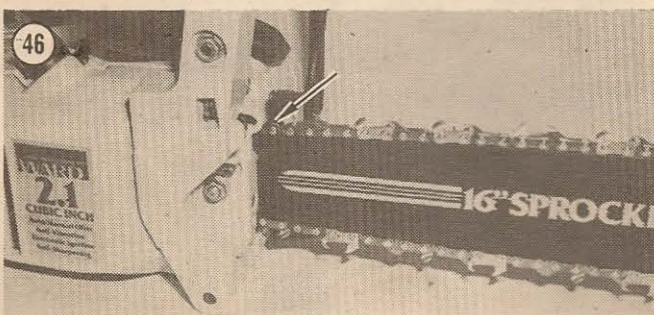

7. Pull the starter handle slowly until you feel the starter engage, then give a smooth, rapid and short pull. Allow the starter rope to rewind slowly. Never let the starter rope snap back from the extended position. Repeat until the engine first fires. (Fig. 48)
8. Push the choke knob in after the engine first fires. Pull the starter. If the engine fires and does not continue to run, pull the choke knob out and pull the starter until the engine starts. Then push the choke knob in.
9. Squeeze the throttle trigger slightly to release the throttle latch button.
10. Use the choke and throttle trigger to keep the engine running until it is warmed up. Do not run the engine at full throttle unless you are cutting wood.

### To Stop

1. Release the throttle trigger and allow the engine to return to idle speed.
2. Place the saw on a clear, firm and flat surface.
3. Move the ignition/stop switch to the "STOP" position.  
**CAUTION:** When it is necessary to stop the saw immediately, simply move the ignition/stop switch to the "STOP" position.

### CARBURETOR ADJUSTMENT (Fig. 49)

Carburetor adjustment is critical and if done carelessly can damage the carburetor and engine.

**NOTE:** Before making any adjustments make sure the air filter is clean. Very often a dirty air filter will make the engine operate as though the carburetor needed adjustment.

For best results, we suggest you have your Wards Service Center make required carburetor adjustments. They have the training, experience, and tools necessary to properly prepare your saw to meet factory performance specifications. However, if it becomes necessary for you to make carburetor adjustments yourself, be certain to observe the following.

1. Carefully turn the low and high speed mixture needles clockwise until resistance is felt. Do not turn the needles in too tight or you can damage the needle tips and their seats. Then open (turn counterclockwise) each needle 1 turn.
2. Start the engine and let it warm up at low speed. If the engine will not idle without stopping, turn the idle speed screw clockwise until it does.
3. Accelerate the engine several times, adjusting the low speed mixture needle to obtain a smooth, rapid acceleration without hesitation or falter. If the needle is turned in too far, the engine will hesitate or falter when accelerated. If the needle is turned out too far, the engine will run rough and smoke heavily when accelerated.
4. Adjust the high speed needle for best power under load. Do not judge by the sound; judge by the way the saw cuts. Final position of the high speed needle will usually be about 1 turn open.
5. Check idle operation again. It may be necessary to re-adjust slightly for smooth idle and acceleration.

**CAUTION:** Engine performance is determined by the cutting speed and ease of operation under load. Therefore, do not adjust the carburetor for maximum sound level as this is likely to result in a lean condition which can cause engine damage.



### QUIK-SHARP OPERATION (TMY-24068B)

Your Wards Chain Saw is equipped with a **QUIK-SHARP** Assembly which allows you to sharpen your saw chain automatically. The **QUIK-SHARP** system requires the use of Wards AS370G saw chain. The **QUIK-SHARP** system will not work with any other type saw chains.

**QUIK-SHARP.** Attempting to operate **QUIK-SHARP** with a loose chain can damage the sharpening stone and/or the chain.

1. Start the engine on a clear, firm and flat surface and allow it to warm up.
2. Grasp the rear handle firmly with the left hand and adjusting knob with the fingers of the right hand. Keep hand and fingers away from the hot rear portion of the **CHAIN BRAKE**. (Fig. 50)
3. While running the engine between 1/2 and 2/3 throttle (the correct engine speed for sharpening the chain), press down on the adjusting knob and turn clockwise one click at a time until you see sparks, hold down for 10 or 15 seconds. (Fig. 50)
4. Release the knob and stop the engine.
5. If the grinding stone has been properly adjusted, the entire top edge of the cutter will be shiny. If any portion of the top edge is not shiny or does not reflect a sharpened condition, the adjusting knob must be pushed down and turned one or more clicks until the entire edge is sharpened. (Fig. 51)



The amount of sparks which fly out during the sharpening operation is an indication of correct adjustment of the stone. A light flow of sparks indicates proper adjustment; no sparks or heavy flow of sparks indicates wrong adjustment.



## BREAKING IN A NEW ENGINE

Breaking in a new chain saw engine is very important. Run your engine for its first few minutes at one-third throttle. Increase speed to about half-throttle and run for a few minutes longer. Cut a few limbs or small logs at first. Check chain tension frequently and use the manual oiler button 2 or 3 times a minute.

It is advisable to use a slightly richer fuel mixture during the break-in period. Turn the high speed mixture needle about one-eighth turn counterclockwise from the normal preliminary starting position. After about an hour's operation, turn the adjusted needle back one-eighth turn clockwise.

## STORING A CHAIN SAW

Ideally the saw should be operated for a short period of time (5 minutes) every 30 days. When storing the saw for short periods or transporting it with fuel in the tank, always keep the saw level and with the fuel cap up to avoid leakage from the tank or cap vent.

Never store a chain saw for over 30 days without performing the following procedures.

1. Drain the fuel tank in a safe area. (Fig. 52)
2. Start the saw and run at idle speed until the engine stops. This will remove most of the fuel from the fuel system.
3. Remove the spark plug with a spark plug wrench and pour a teaspoonful of oil through the spark plug hole into the combustion chamber. Pull the starter rope slowly several times to distribute the oil throughout the engine. Replace the spark plug tightly.
4. Remove and clean the bar and chain (use gloves when handling chain). (Fig. 53)

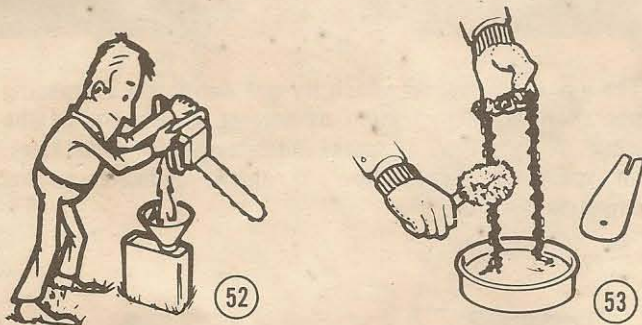

5. Store the chain in a container with oil covering the chain.
6. Apply a heavy film of oil over the entire bar including the groove for the chain. Cover with heavy paper, cloth or plastic.
7. Clean the outside surfaces of the saw.
8. Place a light, protective cloth or plastic covering over the saw, and store the saw and bar in a dry place.

**CAUTION:** The covering should be loose to allow for proper ventilation. Always store away from possible sources of ignition such as furnaces, heaters, etc.

## REMOVAL FROM STORAGE

Remove the spark plug with a spark plug wrench. Pull the starter rope briskly to clear the cylinder of excess oil. Clean and gap the spark plug or install a new spark plug. Fill the fuel tank with the correct fuel mixture and fill the chain oil tank with Wards Chain, Bar and Sprocket Oil.

### A Hint For Easier Starting

A newly manufactured saw or one which has been in storage may sometimes be difficult to start. This is because for shipping purposes one of the manufacturing processes removes all fuel from the fuel tank, fuel lines and carburetor after the engine is tested. Proper storage and long storage periods also result in removing or evaporating all fuel from the engine.

Under these circumstances, it can be easier to start the engine in the following manner. Remove the air filter cover and air filter. Prime the engine by injecting about half a teaspoon of the proper fuel mixture through the carburetor air intake, using an oil can filled with the proper fuel mixture. Take care not to flood the engine and do not spill fuel into the airbox. It usually takes two or three pulls of the starter rope to draw the fuel into the combustion chamber and start the engine. It may be necessary to start the engine two or three times in this manner before the engine will run on its own fuel system. As soon as the engine is running on its own fuel system, stop the engine and replace the air filter and air filter cover. Never do any cutting with the air filter and air filter cover off the engine. (Fig. 54)

**NOTE: DO NOT USE THIS METHOD FOR REGULAR STARTING!**

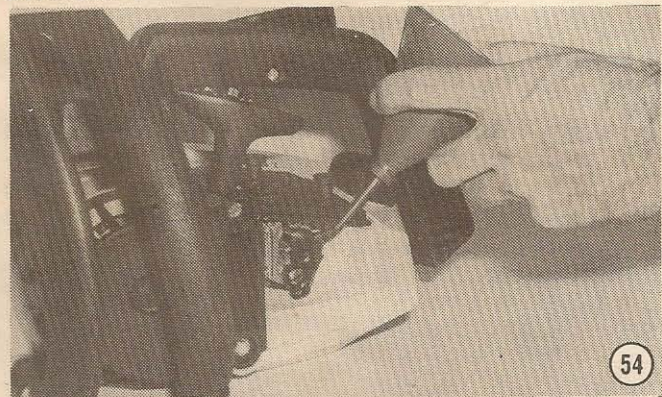

## MAINTENANCE

All chain saw service, other than the items listed here in your Owner's Guide maintenance instructions, should be performed by your authorized Wards Service Center.

Keep the saw, bar and chain clean. Do not allow the filters, muffler, and cylinder fins to become plugged or covered with sawdust, dirt or other foreign material. Never put dirty fuel or chain oil into the saw.

### SPARK PLUG

For efficient operation of the saw engine, the spark plug must be kept clean and properly gapped.

1. Move ignition/stop switch to "STOP" position.
2. Remove the **CHAIN BRAKE**.
3. Disconnect the black rubber connector on end of the wire from the spark plug by twisting and pulling at the same time. (Fig. 55)
4. Remove spark plug with spark plug wrench. Do not use any other tool.
5. Clean electrodes with emery cloth or fine sandpaper. Blow all dust away. Do not use a grit-type cleaning machine. **WEAR EYE PROTECTION DURING THIS OPERATION** (Fig. 56).
6. Adjust the electrode air gap to 0.635 mm (0.025 in.) by bending side electrode only. (Fig. 57)
7. Re-install spark plug and black rubber spark plug wire assembly.
8. For replacement spark plugs see your Wards Service Center.

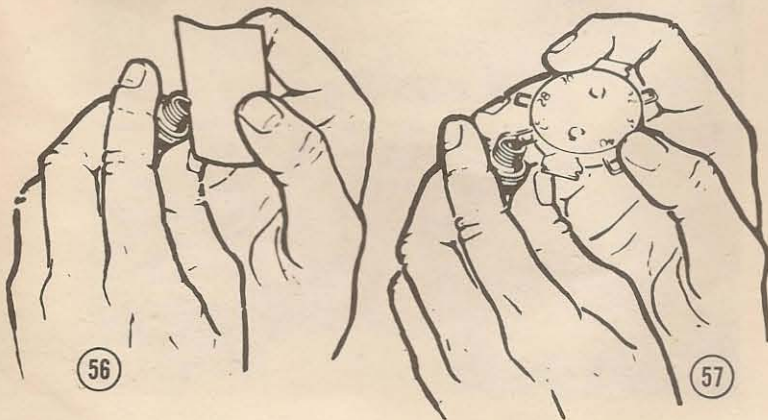

### FUEL CAP VENT

The fuel tank cap is vented to prevent build-up of either pressure or vacuum in the tank. Both conditions will affect operation of the engine. The vent can become plugged through the use of dirty fuel or dirt falling into the fuel tank during refueling operations. If pressure or vacuum develops, have your Wards dealer service the saw.

### FUEL TANK FILTER

The fuel tank filter prevents dirt from entering the fuel line to the carburetor. After a while, dirt will build up on the filter and will cut down the flow of fuel. Or, if water is permitted to enter the fuel tank, the water will get into the filter and prevent the flow of fuel to the carburetor. If any condition affects the filter, install a new filter.

1. Remove the fuel tank cap and lift out the free end of the fuel line.
2. Pull the filter off with a twisting motion. (Fig. 58)
3. Replace the filter. Never operate the saw without the fuel filter!

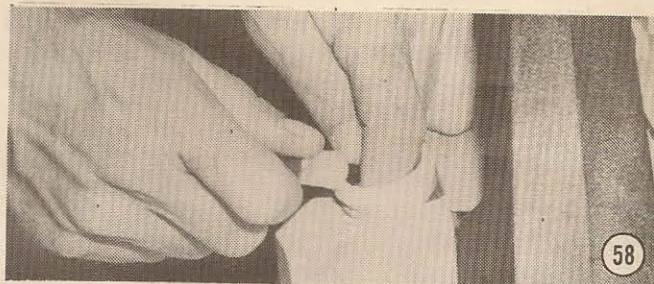

### AIR FILTER

Never operate the saw without the air filter, or dust and dirt will be sucked into the engine and damage it. The air filter must be kept clean. To clean the air filter:

1. Remove the air filter cover by loosening the screw. Then lift off the air filter. (Fig. 59)
2. Wearing eye protection, blow the filter clean with low air pressure or wash it in a clean solvent. Dry it in the open air and away from any open flame. Follow the solvent manufacturer's instructions.
3. Re-install the air filter and cover, being certain the top edge of the cover fits onto the retaining ridge on the air box cover. Make sure the cover is secure. When cutting under dusty conditions, it is advisable to carry several clean filters and change the filter as needed throughout the working day.

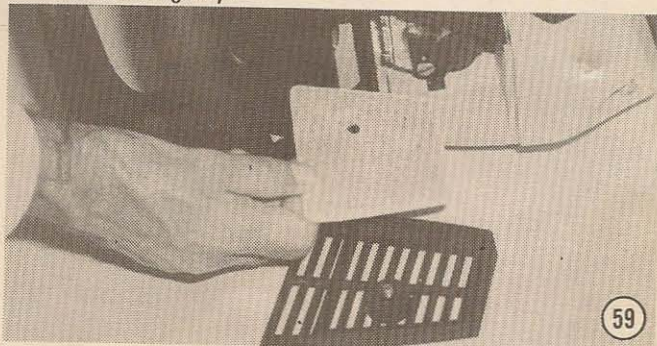

## STARTER COVER AND COOLING FINS

The air inlet openings of the starter cover and the cylinder cooling fins must be kept clean or the engine will become overheated during cutting operations. Cleaning can easily be accomplished by removing the starter cover and then the **CHAIN BRAKE** in order to clean the air inlet openings.

1. Remove the starter cover and use a small wooden scraper to remove dirt and sawdust packed into the openings. Use a soft bristle brush to finish cleaning the cover. Make sure the starter pulley turns freely and easily. (Fig. 60)
2. Clean the vanes on the flywheel and the other parts of the engine that became visible when the starter cover was removed.
3. Remove the **CHAIN BRAKE**, chain and bar. Scrape all dirt, grass, wood chips, etc. from the cooling fins on the cylinder head. Use a thin scraper or stiff brush. (Fig. 61)
4. Re-install the bar, chain, and **CHAIN BRAKE**.
5. When re-installing the starter cover, ensure that the starter pawls are aligned at the top and bottom of the saw. Slide the cover into position lining up the screw holes and making sure that the retaining guide overlaps the housing at the front of the saw. (Fig. 62)

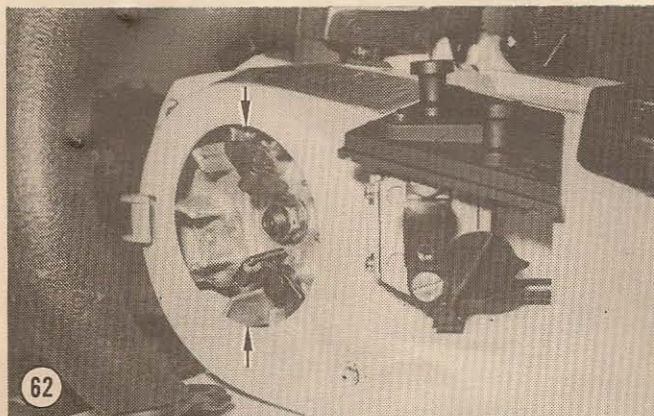
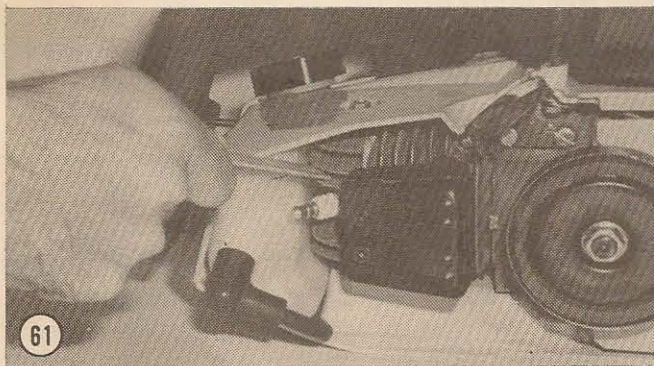
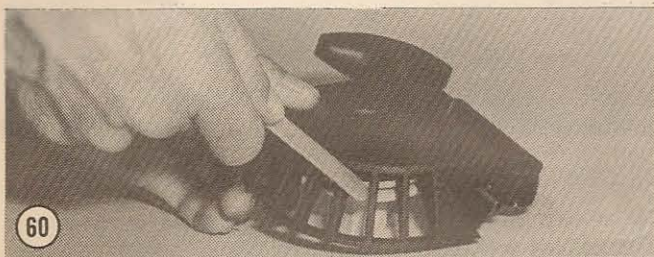

## MUFFLER AND EXHAUST PORT

Operating the saw with a dirty or faulty muffler can lead to damage of the engine. Never run the engine without a muffler.

After each 50 hours of operation, it is advisable to remove, clean and inspect the muffler. At the same time, any carbon should be removed from the exhaust port.

It is also recommended that the spark arrester screen be inspected daily. If wear or corrosion is observed, the screen should be replaced. If the openings are plugged, the screen should be cleaned.

**WARNING:** Always ensure that the saw is cool before maintenance is performed on the muffler.

1. Remove the **CHAIN BRAKE**.
2. Use a 4 mm (5/32 inch) allen wrench to remove the two screws which hold the exhaust deflector onto the muffler. Then remove the screw from the middle of the spark arrester screen. (Fig. 63)
3. Remove the remaining two allen head screws and separate the muffler from the cylinder. (Fig. 63)
4. Clean away all carbon deposits with a scraper blade, wire brush, or by washing with a good solvent. Replace any broken or damaged element.
5. While the muffler and spark arrester are removed from the saw, examine the exhaust port for evidence of carbon around the port. Clean the port as follows:
  - A. Pull the starter rope slowly until the piston covers the port completely.
  - B. Use a wooden scraper and clean in and around the port. Do not use any metal or sharp-edged tool that might slip and scratch the piston rings. (Fig. 64)
  - C. After cleaning, turn the saw exhaust side down and blow loose particles away with compressed air.**WARNING:** Wear eye protection during this operation.



## CHAIN BRAKE MAINTENANCE

The clutch drum and **CHAIN BRAKE** should be kept as clean and free of sawdust as possible to allow free movement and full contact of the brake band. And, as the thickness of the brake band is important to the effectiveness of the **CHAIN BRAKE**, it should be inspected daily for any signs of measurable wear or for any noticeable variation in the thickness of the band. The inspection can be part of the daily preventive maintenance program of rotating the guide bar for longest service life (See Preventive Maintenance Schedule). If such wear is noted, the brake band should be replaced by your Wards Service Center. (Fig. 65)

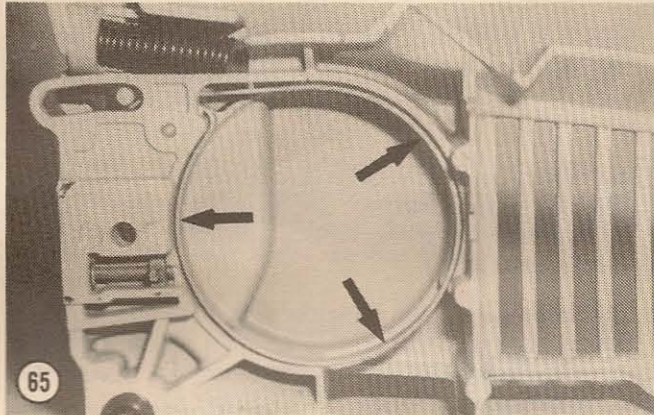

## SPROCKET, CLUTCH AND CLUTCH DRUM

You should always install a new sprocket when a new chain is installed. A damaged or worn sprocket must be replaced with a new one. The saw should never be operated with excessive clutch slippage.

Evidence of slippage is shown when the chain moves very slowly or stops when the engine is running at full throttle.

This will result in a rapid and damaging heat build-up in the clutch and the clutch drum. If the clutch begins to slip, the saw should be taken to a Wards Service Center for servicing.

The clutch and clutch drum should be kept as clean and free of sawdust as possible. If sawdust is allowed to build up the clutch may drag causing the chain to move while the saw is idling.

### Sprocket Replacement:

1. Remove the **CHAIN BRAKE** assembly, bar and chain, and the starter housing:
2. Disconnect spark plug wire.
3. Remove spark plug using spark plug wrench.
4. Sight the flywheel by looking over the clutch drum. Pull the starter handle until a hole appears in the flywheel. Insert a 4 mm (5/32 inch) rod, which is at least 75 mm (3 inches) long, along the channel (seen above the clutch and cylinder) and into the flywheel locking it in place. Care should be taken not to pinch the wires in that area. Loosen the clutch nut using a 13 mm (1/2 inch)\* socket wrench. (Fig. 66)



5. Remove the clutch nut by turning it clockwise, then remove the dust plate and clutch.
6. Remove the sprocket and drum assembly. Lubricate the bearing with a good grade of non-fibrous chassis grease whenever replacing the sprocket and drum assembly.
7. Install the sprocket and drum assembly, the clutch, the dust plate and clutch nut.
8. Lock the crankshaft as explained in step 4 above. Tighten the clutch nut securely by turning it in a counter-clockwise direction.

\*13 mm socket is .012 inches larger than 1/2 inch.

## AUTOMATIC OILER ADJUSTMENT

The automatic oiler is adjusted at the factory for average cutting conditions. Oil flow may be adjusted, however, for special conditions or individual requirements. Turn the adjustment screw clockwise to reduce oil flow and counter-clockwise to increase it. (Fig. 67)

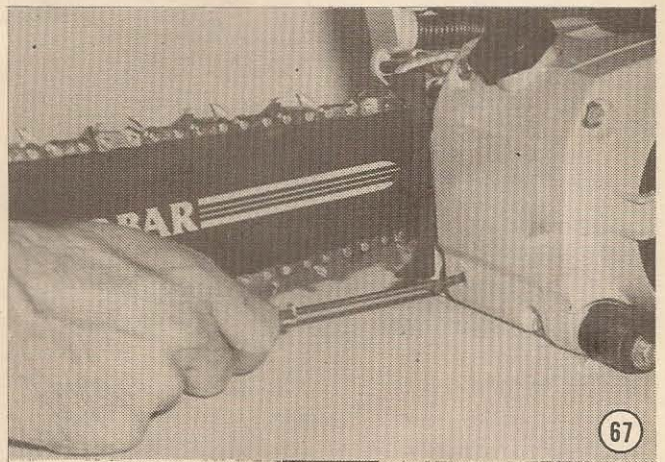

Do not turn the adjustment screw more than 1/4 turn at a time. Check oil flow after each adjustment. When more oil is needed for short periods, it is better to use the manual oiler as a supplement and make no adjustment to the automatic oiler screw.

## GUIDE BAR MAINTENANCE

**Bar wear:** Turn bar over frequently (at regular intervals) to ensure even wear on top and bottom of bar.

**Bar groove:** Bar groove should be cleaned every time chain is removed. Run depth gauge tang or similarly sized instrument along the groove until all residue is cleared. (Fig. 68)

**Oil Passages:** Oil passages at base of bar should be cleaned periodically to ensure proper lubrication of chain and bar groove. This can be done with depth gauge tang or any instrument small enough to insert into passages. (Fig. 69)

The condition of the oil passages should be checked before each use of the saw. While running the saw, press manual oiler button a few times. If passages are clear, the chain will give off a spray of oil with a momentary acceleration of the throttle.

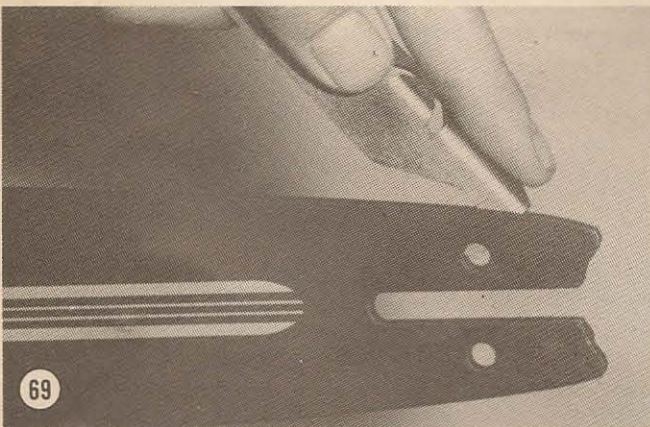
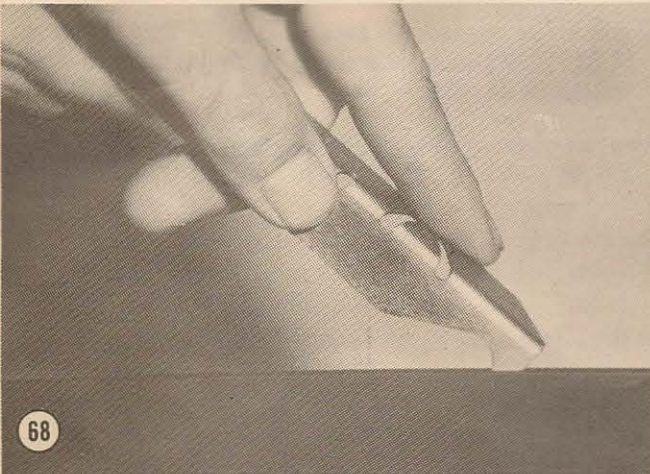

**Lubrication of Sprocket Tip:** For most non-professional usage the sprocket tip will not require lubrication. However, lubrication is necessary for professional usage and under the following circumstances.

1. Continuous cutting of dry or highly abrasive wood.
2. Continuous boring cuts.
3. Continuous cutting with the bar tip.
4. Continuous cutting in wet or snowy conditions.

Under these circumstances lubrication is recommended after every hour of hard usage or after three (3) tanks of gas are consumed.

**NOTE:** Thoroughly clean bar tip before lubrication.

Three methods of lubrication for the sprocket tip may be used.

1. **Needle Nose Grease Gun:** Clean lubricant of No. 1 consistency, force grease into lubrication on one side of bar while covering the lubrication hole on the other side. Rotate sprocket and apply grease until it appears at edge sprocket. Repeat on other side of bar. (Fig. 70)

**NOTE:** Lubri-Gun, part number 68090, is recommended for applying grease to sprocket tip. Its small nozzle is necessary for efficient application of grease to sprocket tip.

2. **Oil Can:** Squirt the appropriate weight motor oil (SAE10 in cold weather, SAE30 in hot weather) into lubrication hole while turning sprocket. Repeat on other side of bar.

3. **Oil Soak:** Fill a small container with clean oil and submerge bar tip in oil. Rotate sprocket several revolutions by hand. Bar tip may be submerged overnight for maximum lubrication.

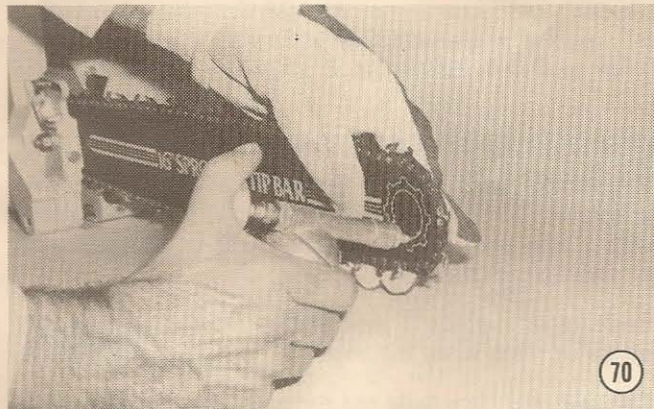

## CHAIN MAINTENANCE

How you care for your saw chain determines the kind of service you will get from it.

The use of a Wards Depth Gauge Tool and a Wards File Guide is recommended.

Chain should be kept clean and sharp for maximum cutting efficiency.

**CAUTION:** Always wear protective gloves when handling chain.

### CHAIN TENSION

Check the chain tension frequently and adjust as often as necessary to keep chain snug on the bar, but loose enough to be pulled around the bar by hand.

Over a period of time, the moving parts of saw chain become worn which results in what is referred to as "chain stretch." When it is no longer possible to obtain the correct chain tension adjustment, a link will have to be removed to shorten the chain. See your Wards Service Center to have this repair performed.

**CAUTION:** Never have more than three (3) links removed from a chain. This could cause damage to the sprocket.

### NEW CHAIN BREAK-IN

1. Run chain at low speed without cutting for 5 minutes. Push manual oiler button every 10 to 15 seconds to provide extra oil.
2. After 5 minutes, shut off engine and recheck and adjust chain tension.
3. Keep the chain well lubricated.
4. Restart and after 10 minutes, shut off engine and check chain tension. Adjust if necessary. Repeat chain tension check often during the first few hours of cutting.

### CHAIN LUBRICATION

Make sure manual and automatic oiler are working. Keep oiler tank filled with clean Wards Chain, Bar and Sprocket Oil.

Use plenty of oil on chain when cutting. Never let chain run dry on the bar. In abrasive wood, use extra oil.

### CHAIN SHARPENING (FOR SAWS WITHOUT QUIK-SHARP) (Fig. 71)

Wards saw chain is a precision manufactured cutting attachment and requires regular inspection and care to maintain peak cutting efficiency. Touch up sharpening may be required once or twice during a day's wood cutting. In some areas where sand or other abrasives have become embedded in the bark of trees, cutter teeth dull more rapidly and more frequent sharpening may be required.

**NOTE:** The **CHAIN BRAKE** can be used to hold the chain in position for sharpening with the engine stopped. Carefully push the brake lever forward until it releases and the brake is engaged.

1. Chain can be sharpened on saw by placing the bar in a bench vise while resting the saw on the bench.

2. Use a 3.9 mm (5/32 inch) round file and a file guide marked for a 30° top filing angle.

**NOTE:** If filing without the file guide, place file on tooth to be sharpened with one-seventh of the file above the top plate edge. Avoid holding the file too low or too high and causing a "hook" or a "backslope." Always file toward the outside of the chain. (Figs. 72, 73)

3. Hold the file at a 30° top filing angle, apply pressure against the face of the tooth, and push the file toward the outside of the tooth. Release pressure on the cutting edge on the return stroke. (Figs. 74, 75)

4. Repeat sharpening stroke until tooth is sharp. Drop file into gullet and clean out with a few light strokes. Do not touch cutting edge of the tooth.

5. Sharpen all teeth on one side of chain before sharpening teeth on the other side. Use same number of strokes on each tooth to help keep all teeth the same length.

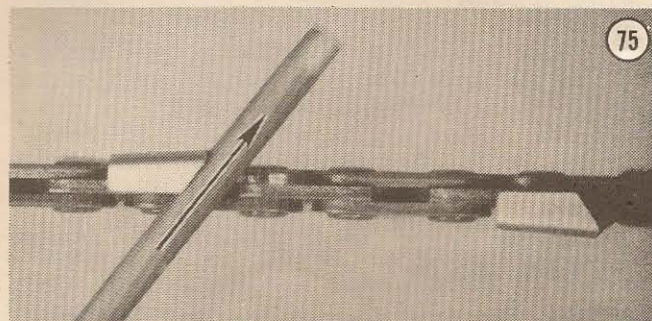
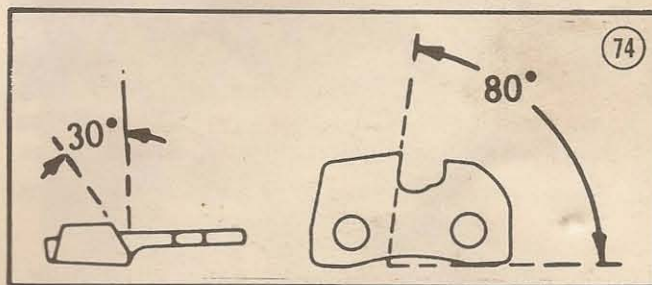
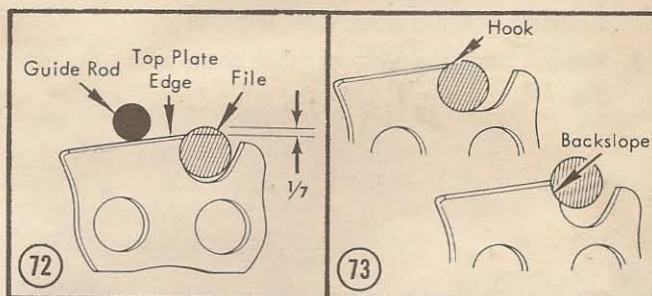
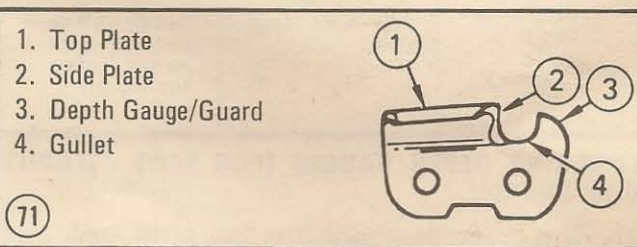

## FILING HINTS

### Proper Cutter Profile

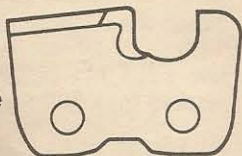

### Common Filing Errors

All of the errors shown must be corrected by refiling.

CUTTER FAULT	CAUSE	RESULT
<p>Hook</p>	(a) File too small. (b) Handle held too high.	Dulls quickly and will not cut smoothly.
<p>Backslope</p>	(a) File too large. (b) Handle held too low.	Cuts slowly and requires extra pressure.
<p>Depth Gauges Too High</p>	Not filed down.	Cuts slowly, requires extra pressure and leads to cutter damage.
<p>Depth Gauges Too Low</p>	Too much filing.	Rough cutting, requires more power (cuts too deep).

### LOWERING DEPTH GAUGES (FOR SAWS WITHOUT QUIK-SHARP)

- Place depth gauge tool over two cutter teeth with depth gauge on first cutter projecting through desired clearance of depth gauge tool. (Fig. 76)
- Remove projecting part of depth gauge with a flat file. (Fig. 76)

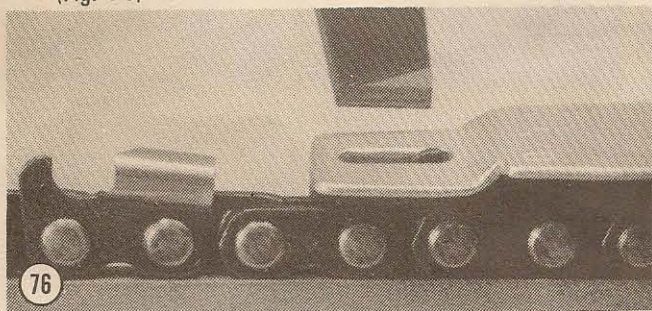

- After lowering all depth gauges, round off their leading edges. Maintain same profile as on original depth gauge.
- Always place depth gauge to be filed at same place on bar when lowering depth gauges.

### TOUCH UP HAND FILING (FOR SAWS WITH QUIK-SHARP) (Fig. 77)

While the QUIK-SHARP system will reduce hand filing to a minimum, the chain will require occasional touch up with a file:

- When the side plate projects approximately 1.6 mm (1/16 inch) ahead of the top plate. (Fig. 78)
- When the cutting edge of the side plate becomes rounded. (Fig. 79)

**CAUTION:** Wear tough gloves whenever handling chain.

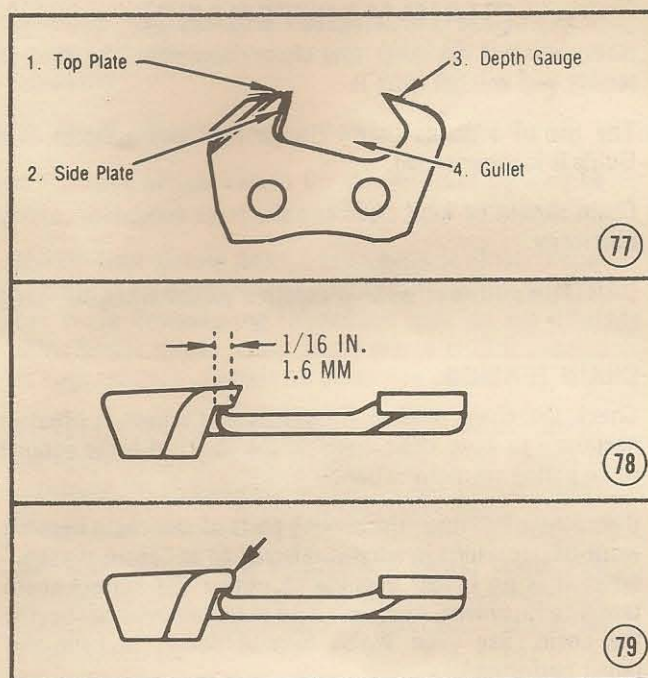

To properly hand file the QUIK-SHARP chain, use a 5/32 inch round file and file guide marked for a 22° filing angle.

**NOTE:** The CHAIN BRAKE can be used to hold the chain in position for sharpening with the engine stopped. Carefully push the brake lever forward until it releases and the brake is engaged.

- Tighten chain on bar so it cannot lean over under filing pressure. After each cutter is filed, move chain so that cutters are always filed at middle of bar.
- Place the file guide on top of cutter so it rests on top plate and depth gauge and 22 degree guide line on file guide is parallel to chain. This gives proper side plate angle of 22 degrees. Never touch the top of teeth with file. Hold file level. (Figs. 80, 81)
- File from the inside of the cutter toward the outside, making light strokes forward and releasing pressure on the file on the back stroke until edge of side plate is sharp. Use same number of strokes on the other cutters.
- Always leave at least .8 mm (1/32 inch) of side plate projecting ahead of top plate or chain will not cut properly. In the event the side plate projection is less than .8 mm (1/32 inch) it can be corrected by sharpening chain with QUIK-SHARP. (Fig. 82)
- Touch up file all cutters on one side before filing cutters on other side.
- Do not let file cut into the chrome underside of the top plate or it will become dull faster.

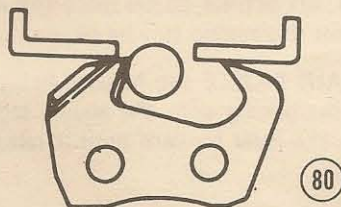

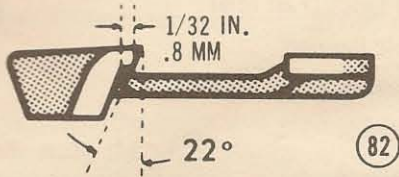
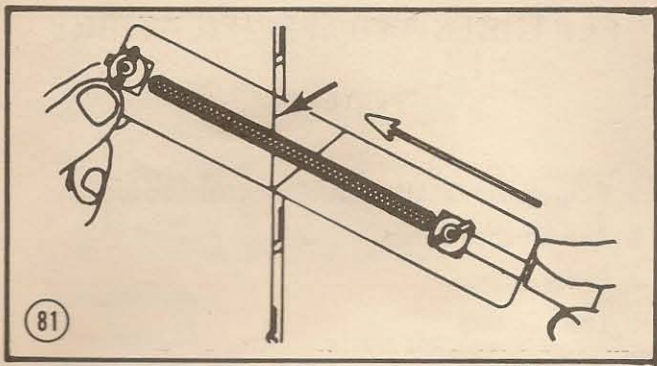

### QUIK-SHARP GRINDING STONE (Fig. 83)

Wards recommends a new grinding stone with each new chain installation. The **QUIK-SHARP** feature is designed to sharpen your chain until you can no longer adjust the knob without it separating from the assembly. When this occurs, it is time to replace the grinding stone.

1. To replace the **QUIK-SHARP** grinding stone, the **QUIK-SHARP** assembly must be removed.
2. The knob is already separated from the assembly, or can be by rotating the knob clockwise until it separates from the assembly. (Fig. 84)
3. Remove the bail wire by snapping it up and over the **QUIK-SHARP** body until it separates.
4. Remove the **QUIK-SHARP** body from the saw by turning it counterclockwise out of the bracket.
5. With a pair of pliers "grab" the retaining washer and squeeze. This buckles or breaks the retainer so it can be readily removed. Wear eye protection during this procedure. (Fig. 85)
6. Remove the grinding stone and discard.
7. Before installing the new grinding stone, make certain upper and lower bushings are in place. (Fig. 83)

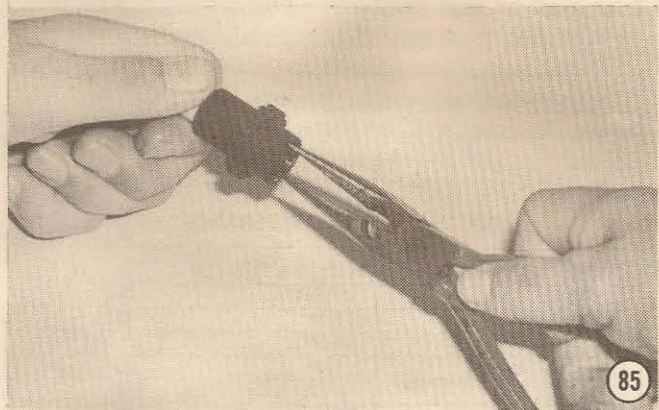
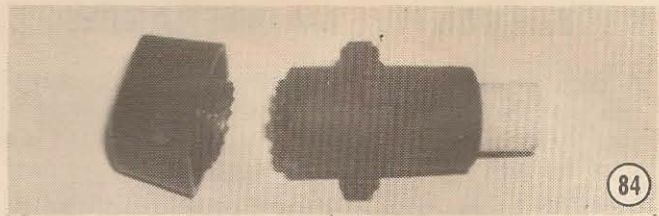
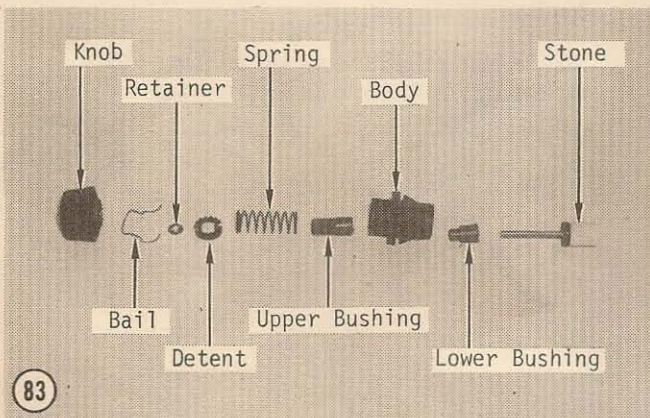

8. Install a new stone and place spring in position. (Fig. 86)
9. Install detent with teeth up onto the upper bushing making certain the detent matches the flats on the upper bushing. (Fig. 87)
10. Compress the spring with detent and push the retaining washer which is supplied with new stone onto the spindle until it bottoms out on the upper bushing. (Fig. 88)
11. Grinding stone should rotate freely, but not have up and down movement.
12. Replace **QUIK-SHARP** body on saw, followed by the bail and adjustment knob. Adjust for subsequent sharpenings.

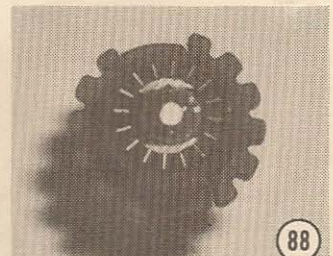
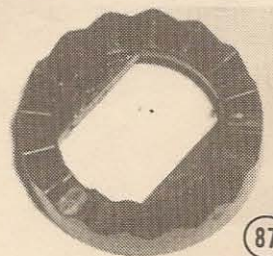
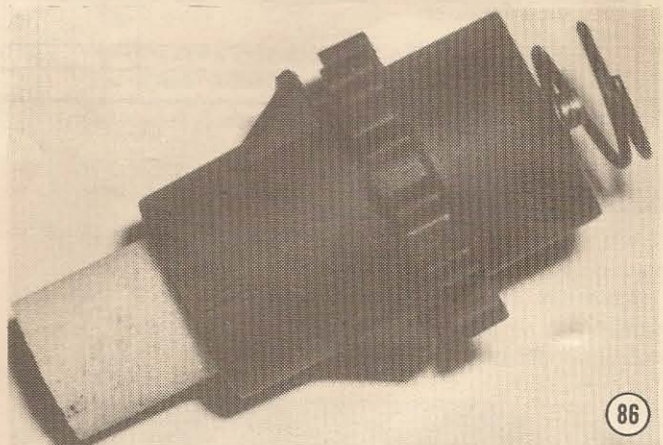

## PREVENTIVE MAINTENANCE

A good preventive maintenance program of regular inspection and care will increase life and improve performance of your Wards chain saw. This maintenance check chart is a guide for such a program. Cleaning, adjustment, and parts replacement may, under certain conditions be required at more frequent intervals than those indicated. The chain oiler must be kept constantly in good operating condition and the chain must be kept snug on the bar.

PREVENTIVE MAINTENANCE CHECK CHART		FREQUENCY			
ITEM	MAINTENANCE	DAILY	WEEKLY	MONTHLY	AS REQD
SCREWS, NUTS, BOLTS	INSPECT & TIGHTEN	●			
CONTROLS	INSPECT	●			
AIR FILTER	CLEAN	●			
	REPLACE		●		
SAWDUST GUARD	CLEAN	●			
CHAIN	INSPECT & SHARPEN	●			
CHAIN BRAKE	INSPECT BAND	●			
BAR	CLEAN & TURN	●			
SHOCK MOUNTS	INSPECT	●			
	REPLACE*				●
SPROCKET	INSPECT	●			
	REPLACE				●
FUEL FILTER	REPLACE				●
OIL SCREEN	CLEAN		●		
MUFFLER	CLEAN			●	
MUFFLER SCREEN	CLEAN	●			
	INSPECT & REPLACE				●
SPARK PLUG	CLEAN & ADJUST		●		
	REPLACE				●
CYLINDER FINS	CLEAN			●	
STARTER ROPE	INSPECT		●		
	REPLACE*				●
CARBURETOR	CLEAN*			●	
FUEL TANK	CLEAN			●	
CARBURETOR BOOT	CLEAN			●	
LAMINATION GAP	CLEAN & ADJUST*			●	
EXHAUST PORTS	CLEAN*			●	
FUEL, OIL & PRESSURE HOSES	CHECK*	●			●
CARBURETOR DIAPHRAGM	REPLACE ONCE A YEAR*				
CRANKSHAFT SEALS	REPLACE ONCE A YEAR*				

\*Recommended for maintenance by a Wards Service Center.

## FEATURES AND SPECIFICATIONS

### FEATURES

1. Wrap-around CHAIN BRAKE Lever/Handguard
2. Anti-vibration Design
3. Safety Trigger
4. Chain Catcher
5. Muffler Shield
6. Throttle Latch (Fast Idle)
7. Electronic Ignition
8. Easy Starting
9. Metric Design
10. Good Balance
11. Light Weight
12. Easy to Service
13. QUIK-SHARP (TMY-24068B)
14. Automatic & Manual Oilers

### SERVICE SPECIFICATIONS

Displacement: 35 cc (2.1 cu. in.)  
 Bore & Stroke: 38 mm x 30 mm (1.5 x 1.2 in.)  
 Sparkplug: CH RDJ8, AC CS 45T  
 Main Bearings: Needle  
 Connecting Rod Bearings: Needle  
 Intake System: Third Port  
 Fuel Tank Capacity: 330 cc (11.2 oz.)  
 Oil Tank Capacity: 100 cc (3.4 oz.)  
 Clutch Engagement Speed: 3800 RPM  
 Idle Speed: 2700 to 2900 RPM  
 Ignition: Electronic  
 Weight TMY-24066B: 4.49 kg (10.0 lbs)  
 Weight TMY-24068B: 4.54 kg (10.1 lbs)

## ACCESSORIES

### CARRYING CASE

(Order Catalogue Article Number 89-30054)

The design of Wards carrying cases permits the bar guard portion of the case to separate from the main body of the case. When the chain saw is lifted out of the case, the bar guard is in its protective position on the bar. (Fig. 89)

Both the carrying case and bar guard are made of heavy-duty plastic for long life and rugged use. The case is double-walled for maximum protection of the saw. Plenty of room inside for accessories and tools.



### CHAIN, BAR and SPROCKET OIL

(Order Catalogue Article Number 89-24195)

For special lubrication properties, we recommend use of Wards Chain, Bar and Sprocket Oil. The dependable and safe operation of your rugged Wards Chain Saw can be enhanced by continued use of this oil, available at your Wards Service Center.

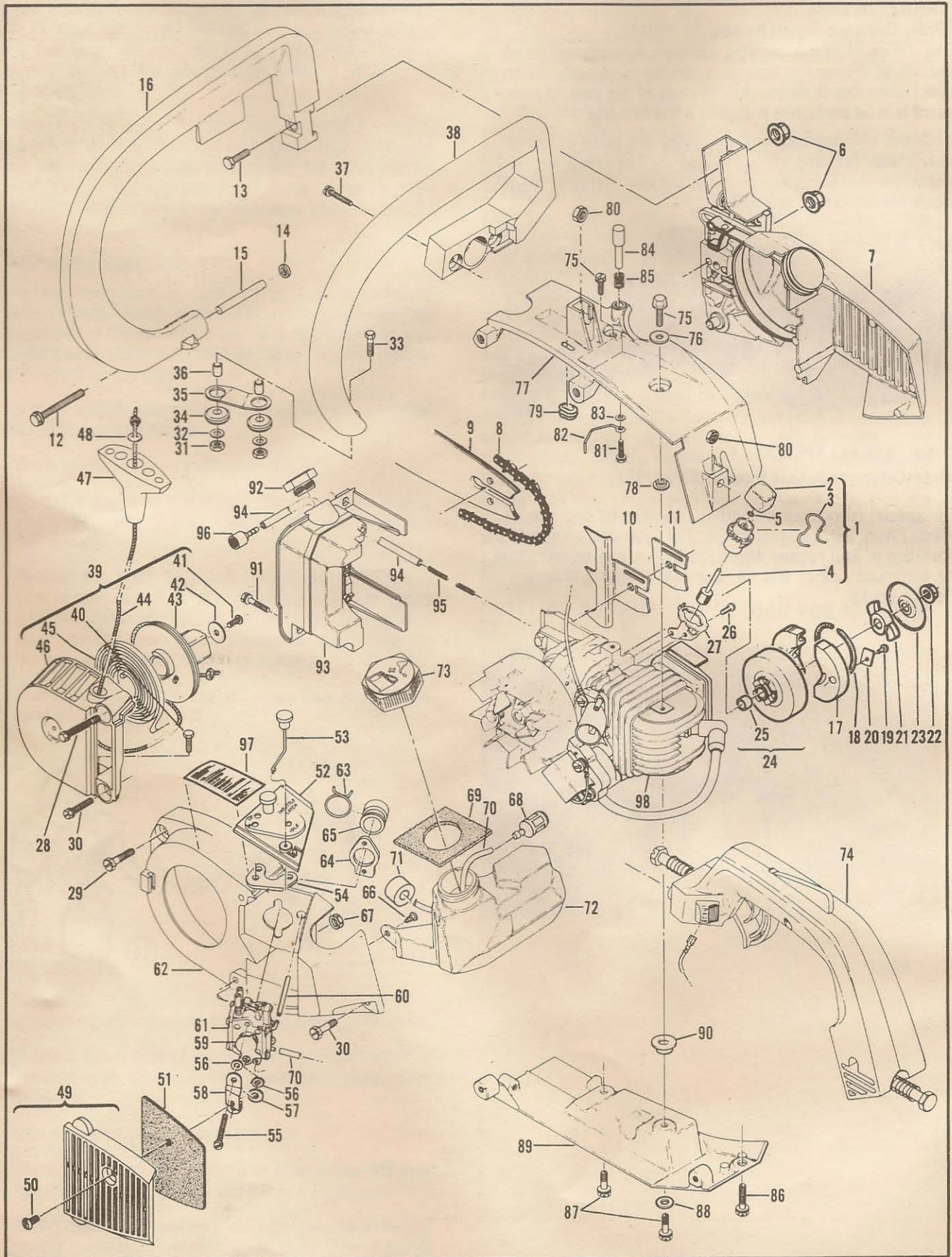

Figure 1. General

FIGURE 1. GENERAL

ITEM NO.	PART NUMBER	DESCRIPTION	UNITS PER ASY.
1	95700	① Grinder Asy-QUIK SHARP	1
2	92582	① . Knob	1
3	94024	① . Bail-QUIK SHARP	1
4	95168	① . Wheel Asy-Grinding	1
5	110968	① . Ring - Retaining	1
6	120029	Nut-Hx Flg. M6.3 x 1.0	2
7		CHAIN BRAKE Asy (Fig. 2)	
8		Chain (Below)	1
9		Bar (Below)	1
10	93157	① Spike	1
11	93148	② Spacer-Bar pad	1
12	120094	Screw-Hx M5 x 50 ST (SEMS)	1
13	120028	Screw-Hx M6.3 x 20	1
14	120045	Washer-M5	1
15	93153	Spacer-Wraparound	1
16	93021A	Lever-Wraparound	1
17	213277	Clutch Asy	1
18	93608	. Spring Asy-Clutch	1
19	110957	. Rivet-FL 1/8 x .547	2
20	85064	. Plate-Clutch shoe	2
21	94242	. Rotor-Clutch	1
22	94244	Nut-Clutch	1
23	94243	Plate-Dust	1
24	95197	Drum/Spkt/Brg. Asy	1
25	91222	. Bearing	1
26	120025	① Screw-Pan M5 x 10	2
27	93095	① Bracket-QUIK SHARP	1
28	120096	Screw-WH M5 x 55 ST	1
29	120095	Screw-WH M5 x 20 ST	2
30	120098	Screw-WH M5 x 18	1
31	120044	Nut-Hx M5 Lock	2
32	120045	Washer-M5	2
33	120041	Screw-Hx M5 x 22	1
34	110989	Grommet	2
35	93152	Link	1
36	93057	Spacer-Mount	2
37	120036	Screw-Pan M4 x 25 (SEMS)	2
38	92983A	Frame	1
39	213258	Starter Asy	1
40	120041	. Screw-Hx M5 x 22	1
41	110041	. Screw-Pan 8-32 x .5	1
42	68497	. Washer	1
43	213261	. Drum/Rope Asy	1
44	83203	. . Rope-Starter	1
45	83078	. Spring-Starter rewind	1
46	94606	. Housing Asy-Starter	1
47	91255	Kit-Starter handle	1
48	105490	. Washer-Starter handle	1

ITEM NO.	PART NUMBER	DESCRIPTION	UNITS PER ASY.
49	94610	Cover Assembly - Air filter	1
50	93626	. Screw - Pan M5 x 10	1
51	94970	Filter - Air	1
52	94608	Cover Assembly - Air box	1
53	214316	. Rod Assembly - Choke	1
54	94721	. Seal - Air	1
55	120049	Screw - Pan M5 x 40	2
56	94902	Washer - Choke	2
57	111037	Washer - Wavey	1
58	94904	Bracket - Choke	1
59	94903	Plate - Choke	1
60	93151	Hose - Pulse	1
61		Carburetor (Figs. 3, 4)	
62	94604	Housing - Fan	1
63	94302	Clip - Spring	1
64	92747	Flange - Carburetor mounting	1
65	92746	Boot - Carburetor	1
66	111002	Screw - Pan 10-16 x .5	1
67	94501	Nut - Hx M5 x 0.8 Thin	1
68	93720	Pickup - Fuel	1
69	94491	Seal - Fuel vent	1
70	93997	Hose - Fuel	1
71	90869	Filter - Vent	1
72	95301	Kit - Fuel tank	1
73	95300	. Cap Assembly - Fuel	1
74		Handle Assembly (Fig. 5)	
75	213369	Screw - Hx M6 x 1 Wh	2
76	213370	Washer - Insulating	1
77	214153	Kit - Top shroud	1
78	214350	. Insulator	1
79	94192	Grommet	1
80	120034	Nut - Hx M6 .3 x 1.0	2
81	110999	Screw - Hx 6-20 x 5/8 WH	1
82	94540	Rod - Oiler	1
83	100001	Washer - Plain	1
84	93304A	Knob - Oiler	1
85	93634A	Spring - Compression	1
86	120095	Screw - Wh M5 x 20 ST	1
87	213369	Screw - Hx hd M6 x 1 Wh	2
88	213370	Washer - Insulating	1
89	214155	Kit - Button shroud	1
90	214350	. Insulator	1
91	120095	Screw - WH M5 x 20 ST	2
92	93274	Cap - Oil	1
93	94613	Tank Assembly - Oil	1
94	94405	. Hose - Oil pickup	1
95	93998	. Spring - Oil hose	1
96	92465	. Pickup - Oil	1
97	95847	Plate - Name (TMY-24066B)	1
97	95846	Plate - Name (TMY-24068B)	1
98		Powerhead Assembly (Fig. 6)	

① Used on TMY-24068B models.  
② Used on TMY-24066B models.

BAR & CHAIN

TMY-24066B		
ARTICLE NUMBER	PART NUMBER	DESCRIPTION
89-24245	94640	Bar Asy - 14" Spkt. Tip
	91-49C	Chain Assembly
	90167	Chain Repair Kit

TMY-24068B		
ARTICLE NUMBER	PART NUMBER	DESCRIPTION
89-24289	94630	Bar Asy - 16" Spkt. Tip
	24539-54C	Chain Assembly
	92605	Chain Repair Kit

Part numbers which have one or more dots (.) preceding their descriptions may be ordered individually, but they are also included in the kit or assembly whose description begins directly above the dot(s).

FIGURE 2. CHAIN BRAKE ASSEMBLY

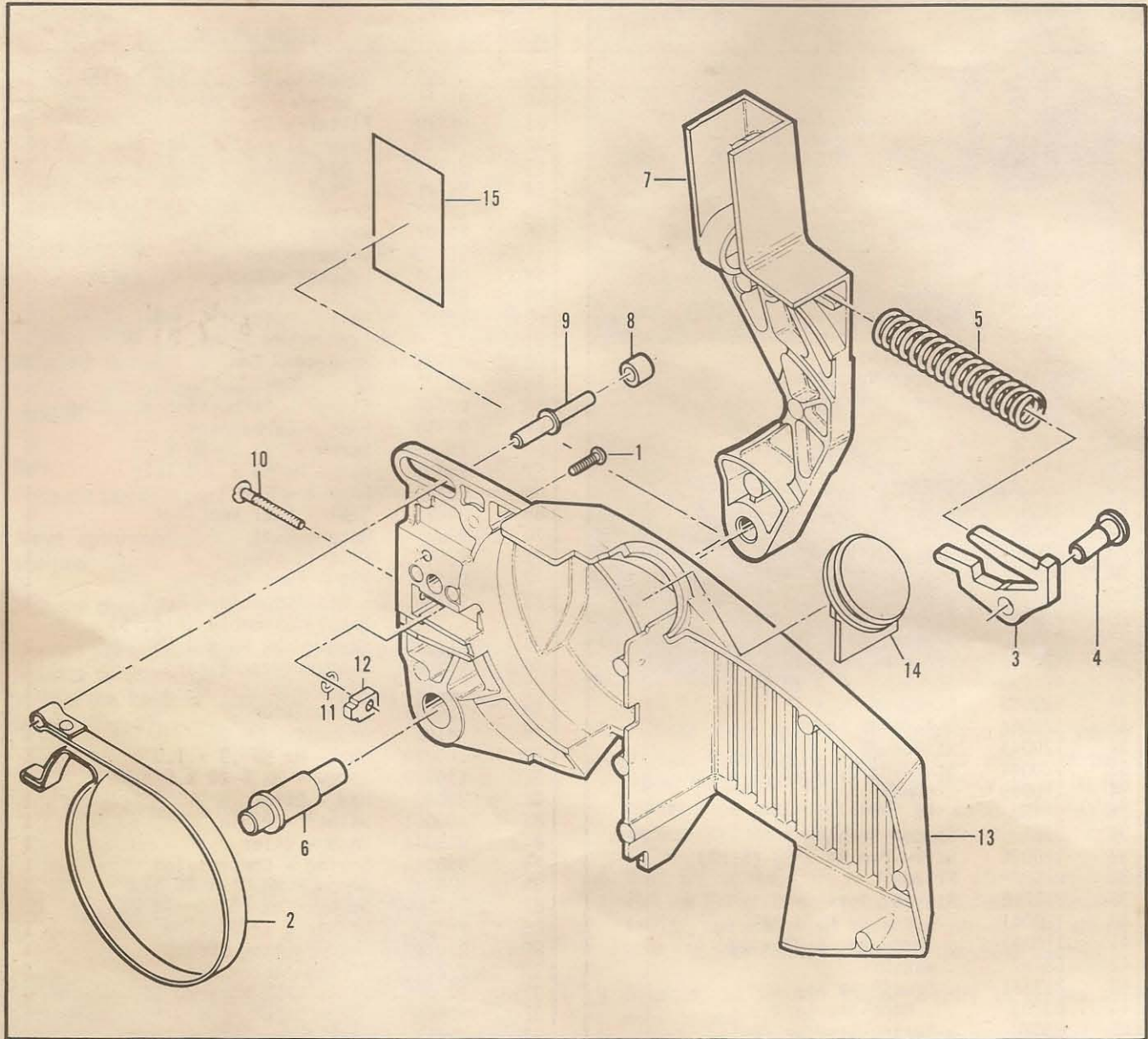

ITEM NO.	PART NUMBER	DESCRIPTION	UNITS PER ASY.
	214369	CHAIN BRAKE Assembly	1
1	111047	. Screw-Pan 8-32 x 5/8	1
2	94709	. Band-Brake	1
3	94006	. Latch	1
4	93602	. Pivot-Latch	1
5	94007	. Spring-Compression	1
6	92482	. Pivot-Lever	1
7	94617	. Lever-Actuating	1
8	214368	. Bearing-Roller	1

ITEM NO.	PART NUMBER	DESCRIPTION	UNITS PER ASY.
9	213907	. Pin-Roller	1
10	90658	. Screw-Adjusting	1
11	110907	. Ring-Retaining	1
12	84929	. Nut-Bar Adjusting	1
13	94616	. Housing-Brake	1
14	93528A	① Cover-QUIK SHARP	1
15	94634	Plate-Name (TMY-24066B)	1
15	94619	Plate-Name (TMY-24068B)	1

① Used on TMY-24066B models.

Part numbers which have one or more dots (.) preceding their descriptions may be ordered individually, but they are also included in the kit or assembly whose description begins directly above the dot(s).

FIGURE 3. CARBURETOR ASSEMBLY

One of two carburetors alternately used. Identify carburetor make (stamped on pump cover assembly, item 7) before ordering parts.

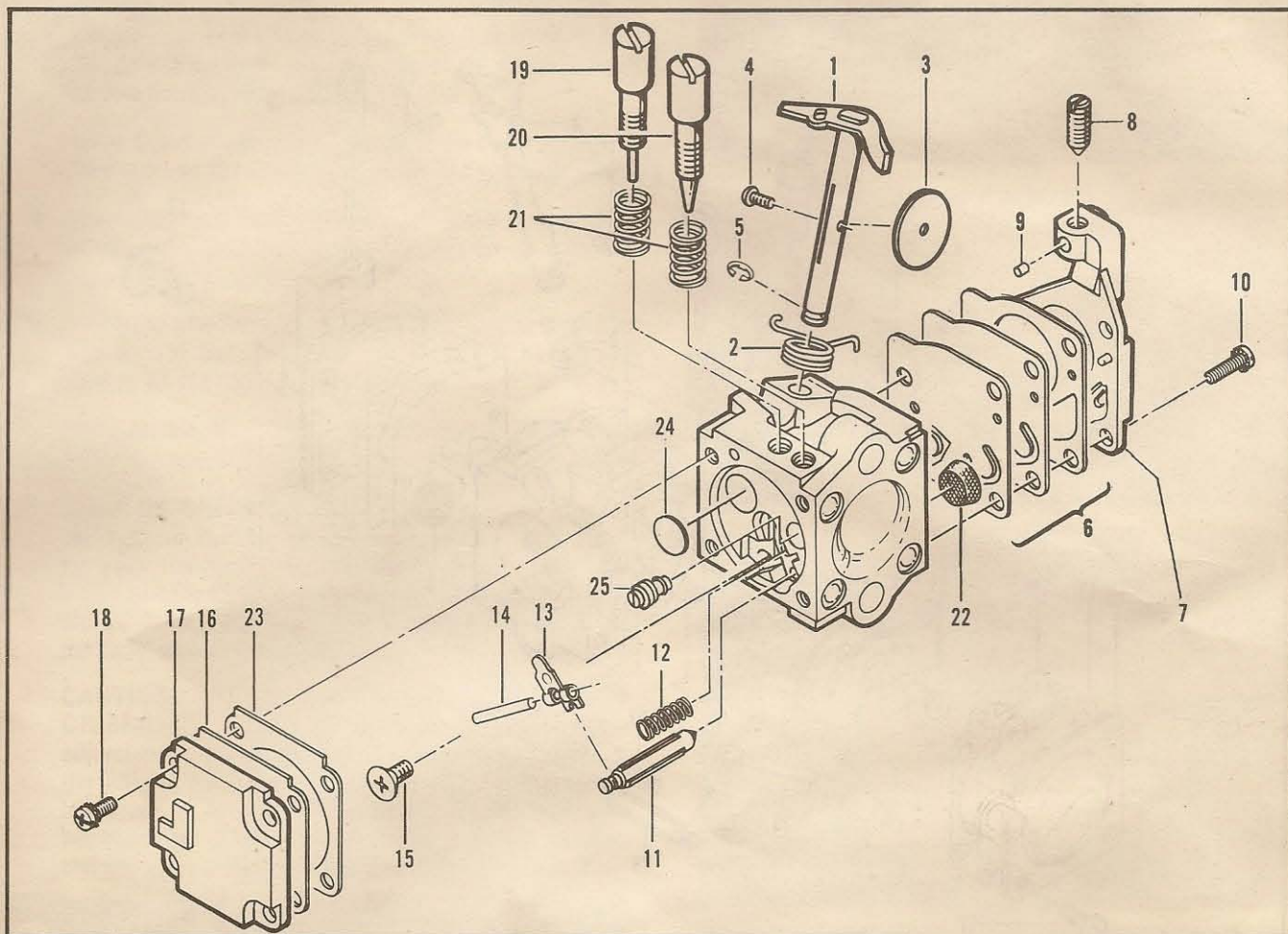

ITEM NO.	PART NUMBER	DESCRIPTION	UNITS PER ASY.
	93524A	① Carburetor Asy (Zama)	1
1	94205	. Shaft Asy - Throttle	1
2	91802	. Spring - Throttle return	1
3	91803	. Plate - Throttle	1
4	91804	. Screw - Plate	1
5	91805	. "E" Ring	1
6	91824	②. Kit - Diaphragm & Gaskets	1
7	94206	. Cover Assembly - Pump	1
8		. . Screw - Idle speed	1
9		. . Insert - Friction	1
10	91809	. Screw - Pump cover	4
11	91810	②. Needle - Inlet	1
12	91811	②. Spring - Lever	1

ITEM NO.	PART NUMBER	DESCRIPTION	UNITS PER ASY.
13	91812	②. Lever - Inlet needle	1
14	91813	②. Pin - Lever	1
15	91814	. Screw - Lever pin	1
16	91815	②. Diaphragm Asy - Metering	1
17	91816	. Cover - Diaphragm	1
18	91817	. Screw - Diaphragm cover	4
19	94209	. Screw - Idle adjust	1
20	94208	. Screw - Main adjust	1
21	91819	②. Spring - Needle	2
22	91820	②. Screen - Filter	1
23	91821	②. Gasket - Metering diaphragm	1
24	92097	. Welsh Plug	1
25	93950	. Orifice - Main fuel	1

① One of two carburetors used. Identify carburetor before ordering parts.

② Contained in Repair Kit, P/N 94210.

Part numbers which have one or more dots (.) preceding their descriptions may be ordered individually, but they are also included in the kit or assembly whose description begins directly above the dot(s).

FIGURE 4. CARBURETOR ASSEMBLY

One of two carburetors alternately used. Identify carburetor make (stamped on pump cover assembly, item 13) before ordering parts.

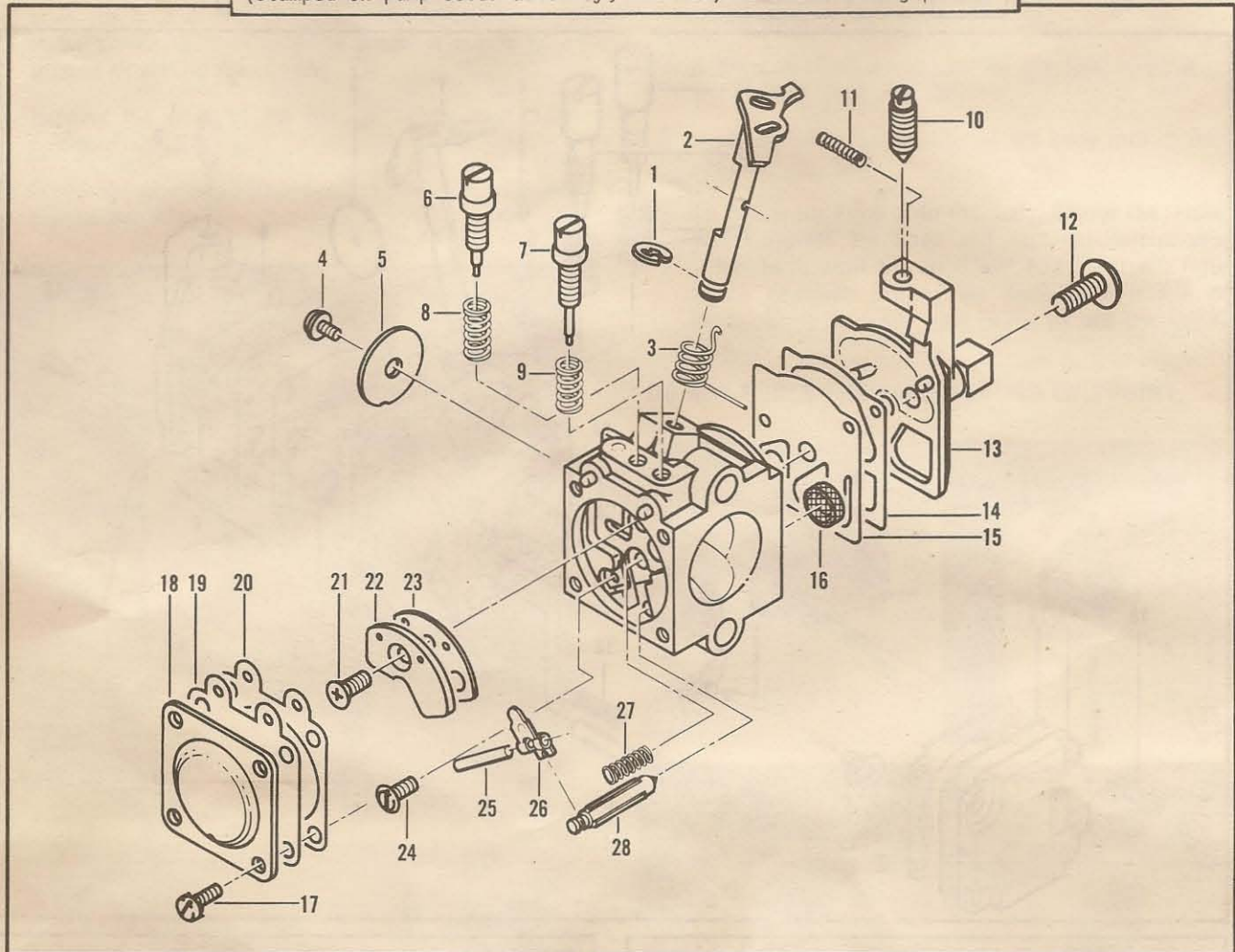

ITEM NO.	PART NUMBER	DESCRIPTION	UNITS PER ASY.
	94411	① Carburetor Asy-Walbro (WA-52)	1
1	94749	. Ring-Shaft retainer	1
2	94752	. Shaft Asy - Throttle	1
3	*94765	. Spring-Throttle return	1
4	*68565	. Screw - Valve	1
5	94753	. Valve - Throttle	1
6	*94766	. Needle - Idle adjust	1
7	*94767	. Needle - Hi speed	1
8	*94763	. Spring - Idle needle	1
9	*67502	. Spring-Hi speed needle	1
10	94762	. Screw - Idle adjust	1
11	*67504	. Spring - Friction	1
12	*94760	. Screw - Pump cover	1
13	94751	. Cover - Pump	1

ITEM NO.	PART NUMBER	DESCRIPTION	UNITS PER ASY.
14	**94754	. Gasket - Pump	1
15	**94758	. Diaphragm - Pump	1
16	*94769	. Screen - Inlet	1
17	*80529	. Screw-Diaphragm cover	4
18	94750	. Cover-Metering diaphragm	1
19	**94759	. Diaphragm Asy-Metering	1
20	**94755	. Gasket - Metering diaphragm	1
21	*94761	. Screw-Circuit plate	1
22	*94771	. Plate - circuit	1
23	**94756	. Gasket - circuit	1
24	*67500	. Screw-Metering lever	1
25	*94770	. Pin-Metering lever	1
26	*94772	. Lever - Metering	1
27	*94764	. Spring-Metering lever	1
28	*67491	. Valve - Inlet needle	1
	*94775	Kit-Gasket/Diaphragm	1

① One of two carburetors used. Identify carburetor before ordering parts.

\* Contained in Repair Kit, P/N 94774.

\*\* Contained in Gasket/Diaphragm Kit, P/N 94775.

Part numbers which have one or more dots (.) preceding their descriptions may be ordered individually, but they are also included in the kit or assembly whose description begins directly above the dot(s).

FIGURE 5. HANDLE ASSEMBLY

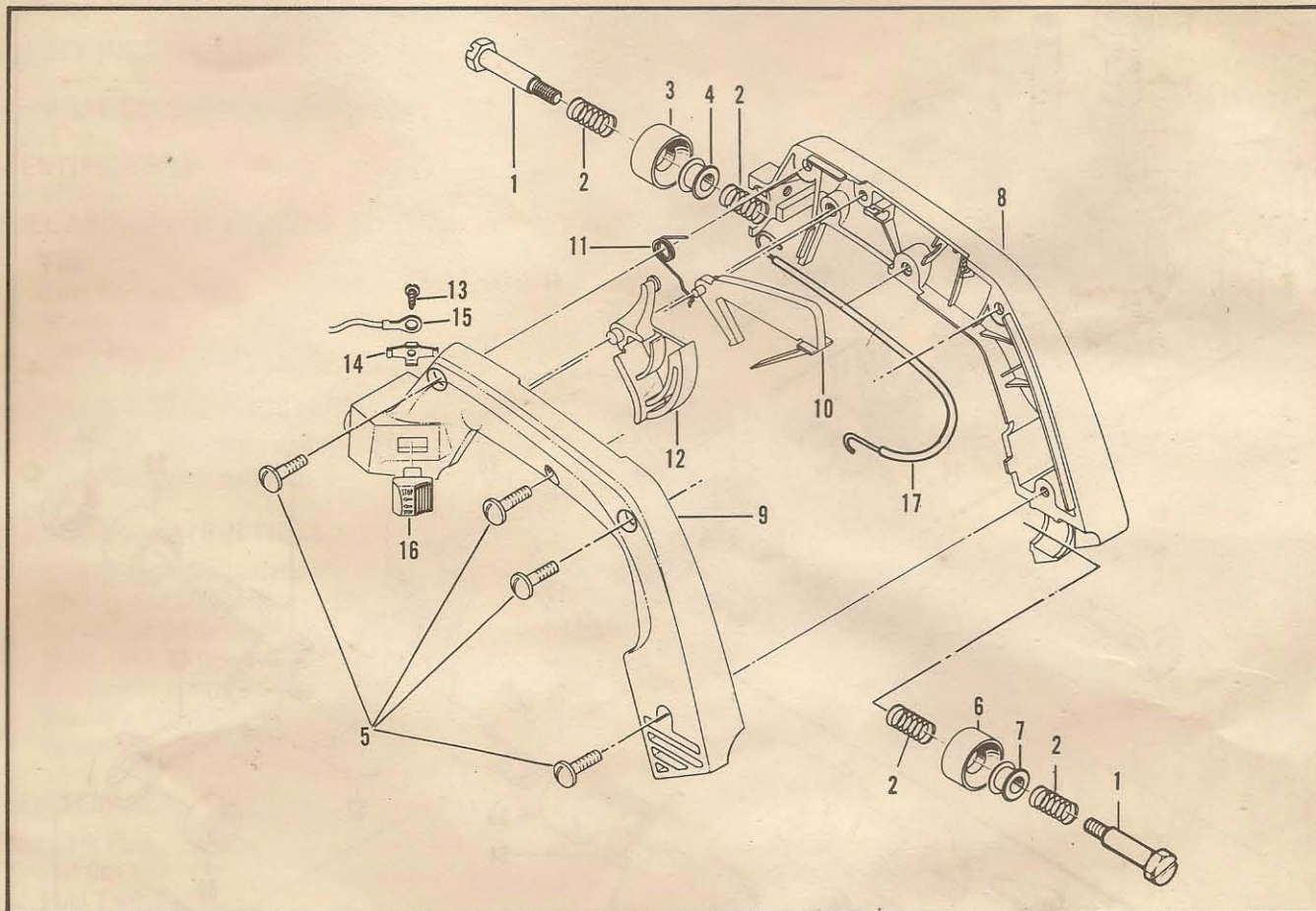

ITEM NO.	PART NUMBER	DESCRIPTION	UNITS PER ASY.
1	93529	Bolt-Shoulder	2
2	93530A	Spring-Mount	4
3	92704	Mount	1
4	94038	Hub-Mount	1
	213230	Handle Asy	
5	111032	. Screw - Pan 10-16 x 5/8	4
6	92704	. Mount	1
7	94038	. Hub - Mount	1
8	213229	. Handle - Right half	1

ITEM NO.	PART NUMBER	DESCRIPTION	UNITS PER ASY.
9	213228	. Handle-Left half	1
10	93310	. Trigger-Safety	1
11	93515	. Spring-Trigger	1
12	213232	. Trigger-Throttle	1
13	110706	. Screw-Pan 8-18 x .50	1
14	62451	. Contact-Ignition switch	1
15	93505A	. Wire Asy-Stop switch	1
16	68846	. Button-Stop switch	1
17	213234	. Wire Asy-Throttle	1

Part numbers which have one or more dots (.) preceding their descriptions may be ordered individually, but they are also included in the kit or assembly whose description begins directly above the dot(s).

TMY-24066B

TMY-24068B

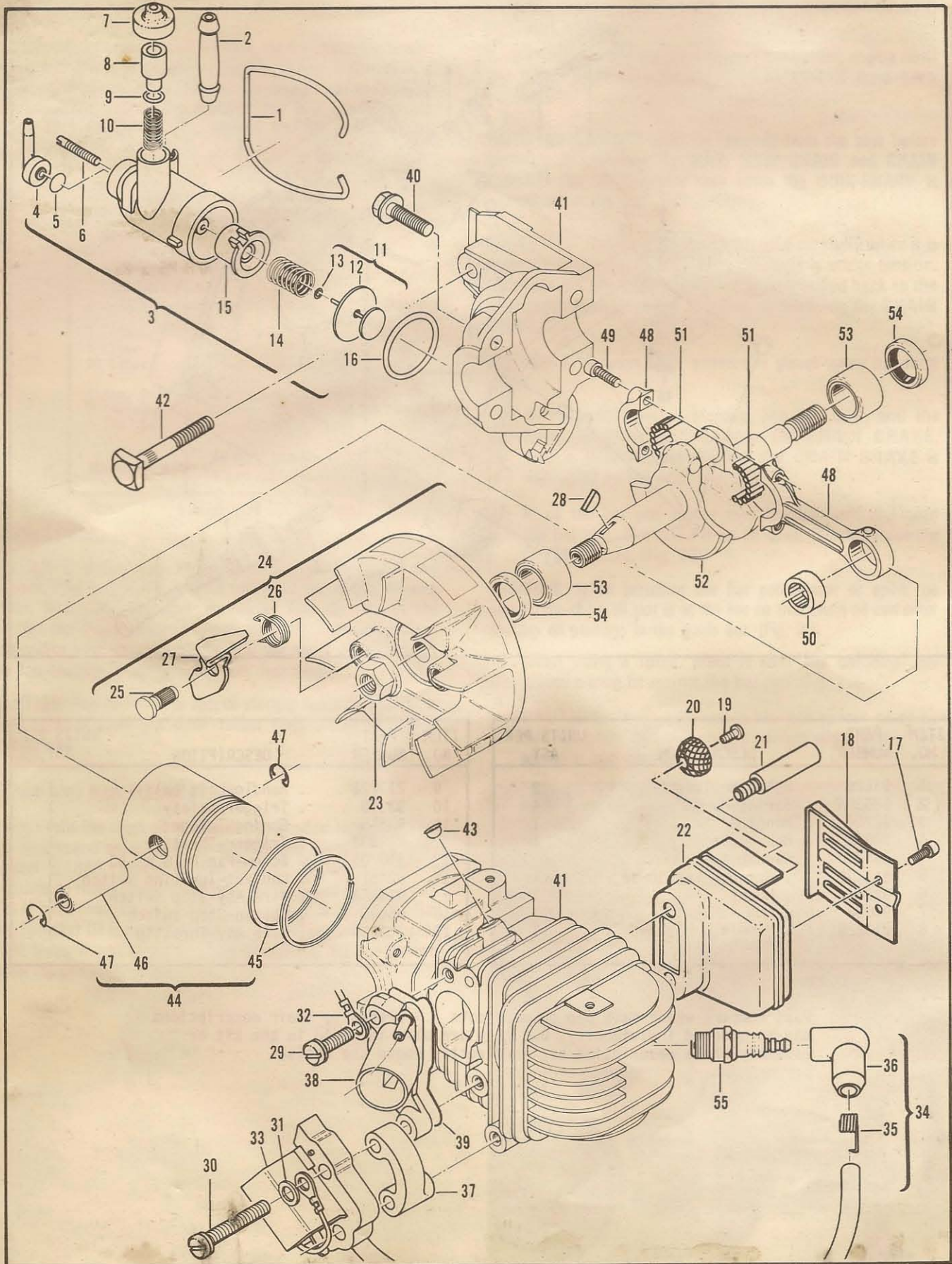

Figure 6. Powerhead Assembly

FIGURE 6. POWERHEAD ASSEMBLY

ITEM NO.	PART NUMBER	DESCRIPTION	UNITS PER ASY.
1	93150	Bail	1
2	83898	Connector-Outlet	1
3	93503	Pump Asy-Chain oiler	1
4	93630	. Connector-Hose	1
5	94115	. Valve-Oiler	1
6	93639	. Screw-6-40 x .800	1
7	62262	. Cap-Oil pump	1
8	93301	. Plunger-Oil pump	1
9	105614	. "O" Ring-.239 x .070	1
10	93632	. Spring	1
11	92204	. Piston Asy-Oiler	1
12	85769	. . Ring-Oil pump piston	1
13	105603	. . "O" Ring-.114 x .070	1
14	83891	. Spring-Return	1
15	83890	. Sleeve-Oil pump	1
16	110653	"O" Ring	1
17	110681	Screw-Skt 10-24 x 1/4	2
18	92961	Deflector-Exhaust	1
19	101987	Screw-Rd 6-32 x 1/4	1
20	83407	Screen-Spark Arrester	1
21	213327	Screw-Special M5	2
22	213346	Body-Cover	1
23	120043	Nut-Hx Flg. M8 x 1.25	1
24	94513	Flywheel and Pawl Asy	1
25	68796	. Pin-Starter pawl	2
26	67814	. Spring-Pawl	2
27	94493	. Pawl-Starter	2
28	102164	Key-Woodruff	1

ITEM NO.	PART NUMBER	DESCRIPTION	UNITS PER ASY.
29	120027	Screw - Pan M5 x 18 (SEMS)	1
30	120112	Screw - Skt M5 x 40	2
31	24236	Washer - Special	2
32	93514A	Wire Assembly - Ground	1
33	93131A	Electronic Ignition Assembly	1
34	95273	. Wire Assembly - Spark plug	1
35	102556	. . Connector - Spark plug	1
36	95266	. . Boot - Spark plug	1
37	93173	Spacer - Coil	1
38	214353	Insulator - Carburetor	1
39*	94869	Sealant - Adhesive	1
40	120097	Screw - Hx W/H M5 x 25	4
41	214150	Cyl/Crankcase Assembly	1
42	92777	. Bolt - Bar mounting	1
43	110914	. Plug - Cup	4
44	94660	Piston Assembly	1
45	94136	. Ring Set	1
46	92836	. Pin - Piston	1
47	111026	. Ring - Snap	2
48	94135	Connecting Rod Assembly	1
49	94654	. Screw - Connecting rod	2
50	110984	. Bearing - Needle	1
51	68095	. Roller - Needle (set of 20)	1
52	92750	Crankshaft	1
53	213282	Bearing - Crankshaft	2
54	83859	Seal - Crankshaft oil	2
55	94882	Spark Plug	1

\* A 2.8 oz. tube of adhesive sealant which must be applied in a 1/8" bead between the carburetor insulator and the cylinder/crankcase assembly. This tube contains enough sealant for many applications.

## TOOLS &amp; ACCESSORIES

ARTICLE NUMBER	PART NUMBER	DESCRIPTION
	94640	Bar Asy-14" Spkt. Tip .375P, .050G (TMY-24066B)
	94630	Bar Asy-16" Spkt. Tip .375P, .050G (TMY-24068B)
89-24245	91-49C	Chain Asy (TMY-24066B)
89-24289	24539-54C	Chain Asy (TMY-24068B)
89-24337	21830	Tool-Depth gauge
89-24339	23597	File-Flat (For 21830 Tool)
89-24333	17518	Chain Breaker Tool
89-24330	23577	File-Round, 5/32"
89-24334	21906	Guide (For 23577 File)
89-24331	23820	File Guide-Clamp-on
	93157	Spike
	94972	Srench
	93797	Wrench-Screwdriver
	91226	Holder-Flywheel
89-30054	94877	Case - Carrying
	90533	Tool-Pressure test
	94416	Adapter-Intake (cylinder)
	94415	Adapter-Intake (air box)
	68917	Adapter-Exhaust

ARTICLE NUMBER	PART NUMBER	DESCRIPTION
	63094	Driver-Wrist pin
	68911	Block-Piston holding
89-24326	94882	Spark plug
89-24194	94884	Engine oil, 6 oz. can
	94885	Engine oil, case of 48, 6 oz. cans
89-24195	94886	Chain, Bar & Spkt. Oil, 1 qt. can
	94887	Chain, Bar & Spkt. Oil, case of 12, 1 qt. cans
	68090	Lubri-Gun
	94930	Lube Gun-Disposable
	67537	Loctite
	69794	Locquic
	110083	R.T.V. Sealant
	110706	Tool-Handle/Throttle trigger screw
	501334	Ignition tester
	94355	Kit-Woodcutter
	94356	Kit-Tool

ARTICLE NUMBER	PART NUMBER	DESCRIPTION
1		
2		
3		
4		
5		
6		
7		
8		
9		
10		
11		
12		
13		
14		
15		
16		
17		
18		
19		
20		
21		
22		
23		
24		
25		
26		
27		
28		
29		
30		
31		
32		
33		
34		
35		
36		
37		
38		
39		
40		
41		
42		
43		
44		
45		
46		
47		
48		
49		
50		
51		
52		
53		
54		
55		
56		
57		
58		
59		
60		
61		
62		
63		
64		
65		
66		
67		
68		
69		
70		
71		
72		
73		
74		
75		
76		
77		
78		
79		
80		
81		
82		
83		
84		
85		
86		
87		
88		
89		
90		
91		
92		
93		
94		
95		
96		
97		
98		
99		
100		

ARTICLE NUMBER	PART NUMBER	DESCRIPTION
1		
2		
3		
4		
5		
6		
7		
8		
9		
10		
11		
12		
13		
14		
15		
16		
17		
18		
19		
20		
21		
22		
23		
24		
25		
26		
27		
28		
29		
30		
31		
32		
33		
34		
35		
36		
37		
38		
39		
40		
41		
42		
43		
44		
45		
46		
47		
48		
49		
50		
51		
52		
53		
54		
55		
56		
57		
58		
59		
60		
61		
62		
63		
64		
65		
66		
67		
68		
69		
70		
71		
72		
73		
74		
75		
76		
77		
78		
79		
80		
81		
82		
83		
84		
85		
86		
87		
88		
89		
90		
91		
92		
93		
94		
95		
96		
97		
98		
99		
100		

TOOLS & ACCESSORIES

ARTICLE NUMBER	PART NUMBER	DESCRIPTION
1		
2		
3		
4		
5		
6		
7		
8		
9		
10		
11		
12		
13		
14		
15		
16		
17		
18		
19		
20		
21		
22		
23		
24		
25		
26		
27		
28		
29		
30		
31		
32		
33		
34		
35		
36		
37		
38		
39		
40		
41		
42		
43		
44		
45		
46		
47		
48		
49		
50		
51		
52		
53		
54		
55		
56		
57		
58		
59		
60		
61		
62		
63		
64		
65		
66		
67		
68		
69		
70		
71		
72		
73		
74		
75		
76		
77		
78		
79		
80		
81		
82		
83		
84		
85		
86		
87		
88		
89		
90		
91		
92		
93		
94		
95		
96		
97		
98		
99		
100		

ARTICLE NUMBER	PART NUMBER	DESCRIPTION
1		
2		
3		
4		
5		
6		
7		
8		
9		
10		
11		
12		
13		
14		
15		
16		
17		
18		
19		
20		
21		
22		
23		
24		
25		
26		
27		
28		
29		
30		
31		
32		
33		
34		
35		
36		
37		
38		
39		
40		
41		
42		
43		
44		
45		
46		
47		
48		
49		
50		
51		
52		
53		
54		
55		
56		
57		
58		
59		
60		
61		
62		
63		
64		
65		
66		
67		
68		
69		
70		
71		
72		
73		
74		
75		
76		
77		
78		
79		
80		
81		
82		
83		
84		
85		
86		
87		
88		
89		
90		
91		
92		
93		
94		
95		
96		
97		
98		
99		
100		

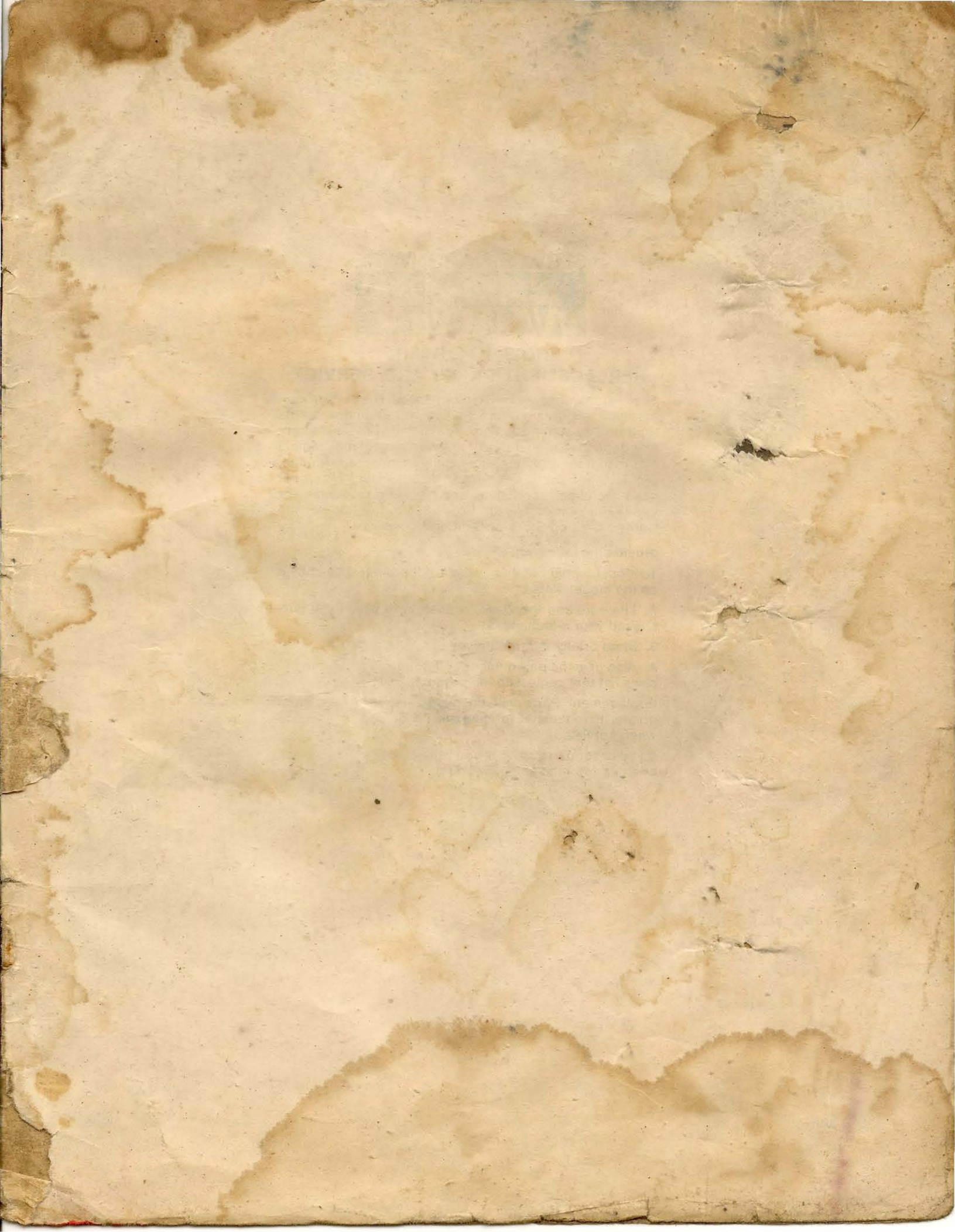

SERVICE NATIONWIDE



**HOW TO OBTAIN  
REPLACEMENT PARTS AND SERVICE**

The merchandise you have purchased from us has been carefully engineered and manufactured under Wards rigid quality standards and should give you satisfactory and dependable operation. However, like all mechanical merchandise, it may occasionally require adjustment, replacement parts or maintenance. Should you ever need technical assistance or parts, please contact or write your nearest Wards Retail Store, Central Service Center, Catalog Store or Catalog House.

**provide the following:**

1. Model, serial number and all of the other data shown on the model plate.
2. The date and the Wards branch from which you purchased your merchandise.
3. State briefly the trouble you are having.
4. Also give the part number or numbers as shown in the parts list that came with the product.

Replacement Parts will be made available at current prices. If requested, prices will be quoted in advance when not listed.

If you order parts by mail, you will pay the transportation charges from the shipping point.