

*Operating Instructions*

***TMH 1600 / TMU 1600***  
***TMH 1600 C / TMU 1600 C***

---

*Turbomolecular Drag Pumps  
Standard Version And For Corrosive  
Gas Processes*



FOR SALES AND SERVICE PLEASE CALL:

**PTB SALES** T :: 866.332.0500  
F :: 626.334.2151  
www.ptbsales.com

DATE SERVICED: \_\_\_\_\_

***VIEW OUR INVENTORY***



	Page		Page
<b>1. Safety Precautions .....</b>	<b>3</b>	<b>5. What To Do In Case Of Breakdowns ?.....</b>	<b>11</b>
<b>2. Understanding The Pumps TMH/TMU 1600 / TMH/TMU 1600 C .....</b>	<b>4</b>	<b>6. Maintenance.....</b>	<b>12</b>
2.1. Main Features.....	4	6.1. Changing The Lubricant.....	12
2.2. Differences Between The Pump Types.....	4	6.2. Cleaning And Changing The Bearing On The Lubricant Pump .....	12
2.3. For Your Orientation.....	4	<b>7. Technical Data.....</b>	<b>14</b>
<b>3. Installation .....</b>	<b>5</b>	7.1. Dimensions .....	15
3.1. Preparations For Installation.....	5	<b>8. Service.....</b>	<b>16</b>
3.2. Installing The Pump, Connecting The High Vacuum Side .....	5	<b>9. Accessories .....</b>	<b>17</b>
Directly Flanging The Pump .....	5	9.1. Lubricant .....	18
Flanging The Pump Via The Bellows .....	5	<b>10. Spare Parts.....</b>	<b>18</b>
Fitting The Splinter Shield.....	6	<b>Declaration Of Contamination.....</b>	<b>21</b>
3.3. Connecting The Fore-Vacuum Side .....	6	<b>Manufacturer's Declaration.....(last page)</b>	
3.4. Connecting The Cooling Unit.....	6		
Water Cooling.....	6		
Air Cooling (Accessory) .....	7		
3.5. Connecting The Venting Valves.....	8		
3.6. Connecting The Electronic Drive Unit .....	8		
3.7. Connecting The Sealing Gas Valve.....	8		
<b>4. Operations .....</b>	<b>9</b>		
4.1. Lubricant Filling .....	9		
4.2. Switching ON.....	9		
4.3. Operational Characteristics Under Gas Load .....	10		
4.4. Heating (optional).....	10		
4.5. Circulatory Lubrication.....	10		
4.6. Switching OFF And Venting.....	10		
4.7. Shutting Down For Longer Periods .....	11		

# 1. Safety Precautions

- ☞ Read and follow all the instructions in this manual.
- ☞ Inform yourself regarding:
  - Hazards which can be caused by the pump;
  - Hazards which can arise in your system;
  - Hazards which can be caused by the medium being pumped.
- ☞ Avoid exposing any part of your body to vacuum.
- ☞ Comply with all safety and accident prevention regulations.
- ☞ Check regularly that all safety requirements are being complied with.
- ☞ Do not operate the pump with open high vacuum flange.
- ☞ Do not carry out any unauthorised conversions or modifications on the pump.
- ☞ When returning the pump to us please note the shipping instructions.
- ☞ Use at least 6 bracket screws to connect the high vacuum flange.
- ☞ Fix down the pump in accordance with the instructions on installation.
- ☞ Do not disconnect the pump cable during operations.
- ☞ When the pump is open, disconnect the electronic drive unit from the mains.
- ☞ After switching off the pump, disconnect the electronic drive unit only once the rotor is at rest.
- ☞ When working on the pump, only open the high vacuum flange once the rotor is at rest.
- ☞ When using sealing gas, the pressure in the hose connection should be limited to 2 bar via the overpressure valve.

## Pictogram-Definitions:



Danger of burns from touching hot parts.



Danger of an electric shock.



Danger of personal injury.



Danger of damage to the pump or system.



Danger of injury from rotating parts.

Modifications reserved.

## 2. Understanding The Pumps

### TMH/TMU 1600 / TMH/TMU 1600 C

#### 2.1. Main Features

##### Turbomolecular Drag Pumps TMH/U 1600

- 1 High vacuum flange
- 2 Fore-vacuum flange
- 3 Cooling water connection
- 5 Electrical connection
- 9 Locking screw/sealing gas connection
- 71 Lubricant filler screw
- 72 Lubricant drain screw
- 73 Sight glass



- TMH/TMU 1600 Standard version
- TMH/TMU 1600 C Corrosive gas processes version

##### Cooling

Standard: Water cooling.  
 Alternative: For the TMH/TMU 1600 air cooling as an accessory (permissible ambient temperature  $\leq 35^\circ\text{C}$ ).

Integrated excess temperature safety feature:  
 Electronic drive unit reduces motor current to zero.

##### Please note:

The TMH/U 1600 C, designed for corrosive gas processes, must be water cooled.

##### Bearings

High vacuum side: Wear free permanent magnetic bearing.  
 Fore-vacuum side: Oil circulatory lubricated bearings with ceramic balls.

##### Proper use

- The Turbomolecular Pumps may only be used for the purpose of generating vacuum.
- The Turbomolecular Pumps may only be operated with a PFEIFFER Electronic Drive Unit and relevant cables.
- The turbopumps must be connected to a backing pump as per Section 3.3.

##### Improper use

Certain types of use are regarded as improper, e.g.:

- Pumping explosive gases.
- Operating the pump in areas where there is a danger of explosions.
- Using accessories not named in this manual and/or not authorised by the manufacturer.

Improper use will cause any rights regarding liability and guarantees to be forfeited.

#### 2.2. Differences Between The Pump Types

- TMH/TMU 1600 Standard version
- TMH/TMU 1600 C Corrosive gas processes version

Feature	TMH 1600 TMH 1600 C	TMU 1600 TMU 1600 C
HV-flange	ISO-K	CF-F
HV-Seal	Viton	Metal
Attainable final pressure	$< 1 \cdot 10^{-8}$ mbar (without baking out)	$< 1 \cdot 10^{-10}$ mbar (with baking out)

#### 2.3. For Your Orientation

##### Instruction in the text

➔ Working instruction: Here, you have to do something.

##### Symbols used

The following symbols are used throughout in the illustrations:

- High vacuum flange
- Fore-vacuum flange
- Sealing gas connection
- Cooling water connection
- Electrical connection
- Venting connection

##### Position numbers

Identical pump and accessory parts have the same position numbers in all illustrations.

## 3. Installation

### 3.1. Preparations For Installation



Do not carry out any unauthorised conversions or modifications on the turbopump.

- Only remove blank flanges on the high and fore-vacuum side just before connecting.
- The turbopumps must not be transported when filled with lubricant.
- Appropriate shielding must be provided (available on request) if magnetic fields > 3 mT are involved.
- If the pump is baked out, the heating sleeve and the body of the pump must be insulated to prevent burning.

### 3.2. Installing The Pump, Connecting The High Vacuum Side

#### Important:

Maintain the utmost cleanliness when fitting all high vacuum parts. Unclean components prolong the pumping time.

#### Use of the splinter shield

A splinter shield in the high vacuum flange protects the pump against foreign particles emanating from the vacuum chamber but it does reduce the pumping speed of the pump by approx. 15%.

For fitting please refer to "Fitting The Splinter Shield".

The high vacuum side can be flanged onto the vacuum chamber either directly or via a bellows.

#### Directly Flanging The Pump

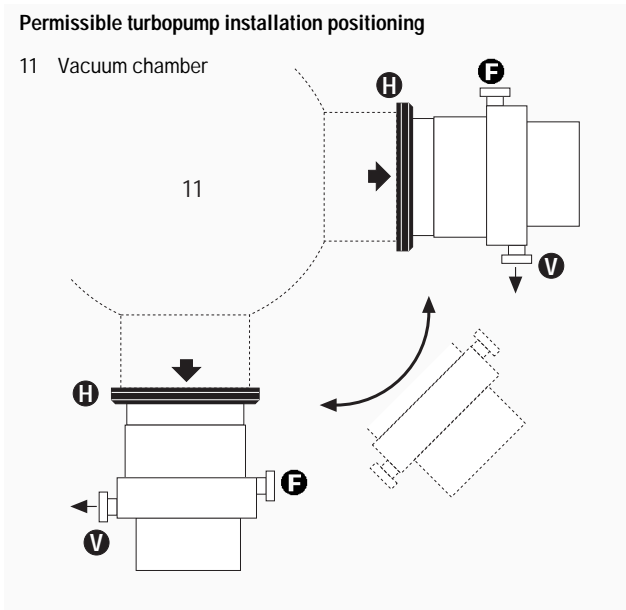

Maximum high vacuum flange axial loading capacity 2000 N (corresponds to 200 kg). No asymmetrical loading on the high vacuum flange.

Where the turbopump is installed horizontally: The fore-vacuum flange of the turbopump must point vertically downwards (maximum deviation  $\pm 15^\circ$ ); otherwise the turbopump could become contaminated and the lubricant pump not properly function.

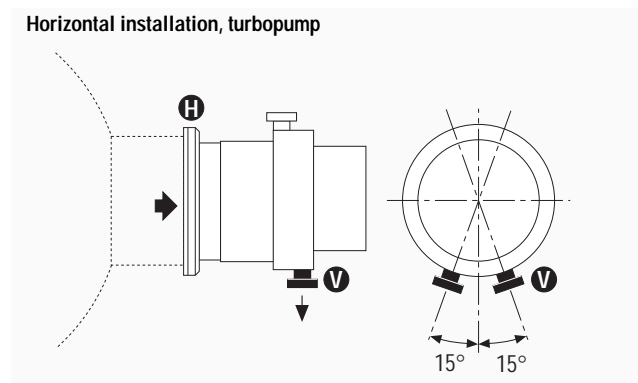

#### Flanging The Pump Via The Bellows

Advantage: Reduced vibration transmission.

The pump must be mechanically bolted onto a holder.

- ➔ Remove the stopper from the threaded hole on the underside (standing surface). Bolt the pump securely onto a holder with M8 screws.

#### Anchoring points on the underside of the turbopump

6 Stoppers (4x)

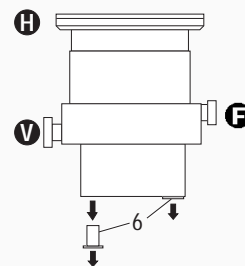

No forces must be transmitted from the pipe system to a pump which is anchored. Support or suspend all pipelines to the pump.

## Fitting The Splinter Shield

Insert the splinter shield in the high vacuum flange so that the recesses in the splinter shield (three pieces, 120° staggered) are positioned over the bar on the casing.

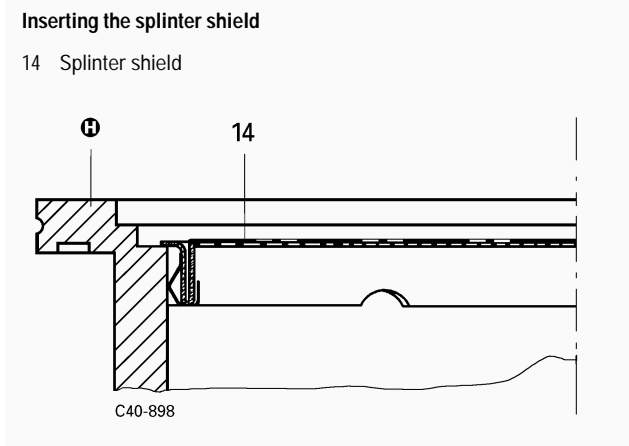

### 3.3. Connecting The Fore-Vacuum Side

Backing pump: Fore-vacuum pressure  $\leq 5$  mbar  
 Recommendation: Oil free Diaphragm Pump MD 4T or rotary vane pump from the PFEIFFER product range (note installation position of the turbopump, see Section 3.2.).

#### Connecting the backing pump

All fore-vacuum line connections: With normal small flange components.



Exhaust gases from the backing pump must be conducted away safely. Ensure the full width of the fore-vacuum flange is not restricted by following components. Exhausted process gases and vapours can be hazardous to health and harmful to the environment.

- ➔ Fit the vacuum safety valve in the fore-vacuum line (in PFEIFFER rotary vane vacuum pumps already integrated as standard). This prevents vacuum chamber venting via the backing pump.
- ➔ With rigid pipe connections: Fit bellows in the connecting line to reduce vibration.
- ➔ Backing pump electrical connection: see operating instructions for the electronic drive unit.

#### Connecting the backing pump

- 1 High vacuum connection
- 2 Fore-vacuum connection, turbopump
- 20 Backing pump
- 21 Intake connection, backing pump
- 22 Vacuum safety valve
- 23 Fore-vacuum line

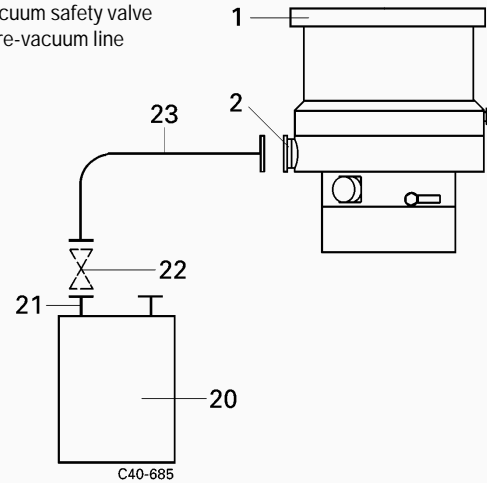

### 3.4. Connecting The Cooling Unit

The Turbopumps TMH/TMU 1600 have been designed to be water cooled as standard.

Air cooling, as an accessory, may only be used where the ambient temperature is  $\leq 35$  °C.

The Turbopumps TMH/TMU 1600 C **must** be water cooled.

#### Water Cooling

Cooling water either

- From the mains or
- From Recycled Water Cooling Unit TZK with closed circuit.

#### Cooling from the water mains:

Mechanically clean, optically clear, no turbidity, no sediment, chemically neutral.

#### Minimum cooling water requirements:

Mechanically clean, optically clear, no turbidity, no sediment, chemically neutral, temperature  $>$  dew point.

Oxygen content:	max.	4	mg/kg
Chloride content:	max.	100	mg/kg
Carbonate hardness:	max.	10°	dH
Consumption of potassium permanganate:	max.	10	mg/kg
Carbon dioxide:			Undetectable
Ammonia:			Undetectable
pH-value:			7-9
Max. fore-line over pressure:	max.	6	bar
Minimum flow rate:			100 l/h at 15°C

#### Connecting to the cooling water mains

- ➔ Fit dirt trap (accessory) in the fore-line.
- ➔ Using circlips, connect fore-line to one of the two cooling water connections.
- ➔ Connect Cooling Water Monitor TCW 002 (accessory) in the return line.
- ➔ Connect return line to the other cooling water connection of the turbopump.
- ➔ Tighten all circlips and ensure hose lines are seated firmly.

### Cooling from the water mains

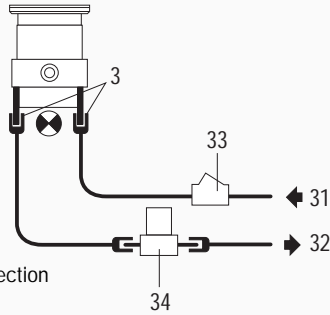

- 3 Cooling water connection
- 31 Fore-line
- 32 Return line
- 33 Dirt trap
- 34 Cooling Water Monitor TCW 002

### Cooling with the Recycled Water Cooling Unit TZK

#### Connecting to the TZK

A dirt trap in the pipeline is not permissible.  
All other steps: As for connection to the water mains.

#### Cooling with the Recycled Water Cooling Unit TZK

- 3 Cooling water connection
- 34 Cooling Water Monitor TCW 002 in the return line
- 35 Recycled Water Cooling Unit TZK

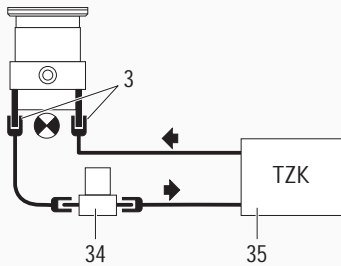

### Air Cooling (Accessory)



Air cooling is only permissible in respect of the standard version TMH/U 1600 and if the ambient temperature  $\leq 35^\circ\text{C}$ .  
Ensure adequate air circulation and ventilation.

#### Fitting the air cooling

- ➔ Drain lubricant as described in Section 6.1.
- ➔ To fit the air cooling unit, position the turbopump horizontally with the fore-vacuum flange pointing down.



The pump must not be stood on its high vacuum flange because this could cause contamination from the lubricant.

- ➔ Remove the stoppers from the threaded holes on the base of the pump.
- ➔ Screw the complete air cooling to the holder with 4 screws and screw spring washers onto the turbo pump.
- ➔ Fill in approximately  $65\text{ cm}^3$  of lubricant in accordance with Section 6.1.

#### Electric connection, air cooling

The electrical connection should be carried out as per the following diagram.

Connection diagram, air cooling

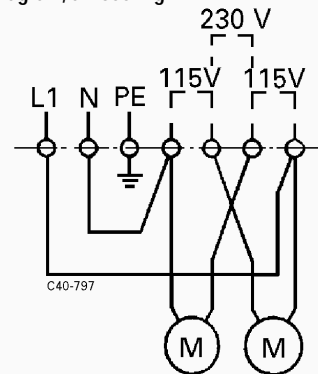

#### Fitting the air cooling

- 1 High vacuum flange
- 2 Fore-vacuum flange
- 4 Venting screw
- 9 Locking screw/sealing gas connection
- 36 Ventilator
- 36a Finger protector
- 36b Buffer
- 37 Holder
- 38 M5 screw and spring washers (4x)
- 64 Lubricant reservoir

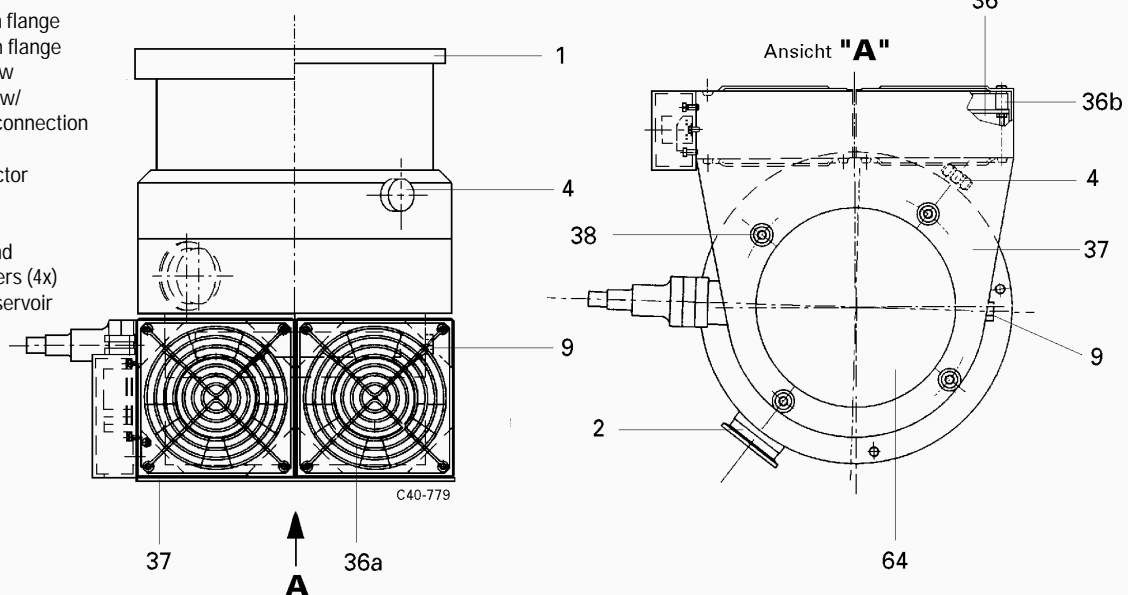

### 3.5. Connecting The Venting Valves

- Manual venting to atmospheric pressure:  
With venting screw (condition on delivery) in the venting connection.
- Automatic venting on switching off and power failure:  
Connection of a venting valve (Accessory).

Venting Valve	Control Unit	Electronic Drive Unit	Venting Procedure After Switching Off Or A Power Failure
TSF 010	not required	immaterial	immediate; venting valve remains open
TSF 012	not required	TCP 380/600	delayed (venting begins at approx. 20% of the nominal rotation speed); venting valve remains open
TVF 012	TCF/TCV 103	TCP 380/600  TCP 380 TCP 600	delayed; 1-30 min.; venting valve closes, delayed, 1-30 min. with TCS 304 with TCS 130/603

#### Fitting the venting valves

See the operating instructions for the respective unit.

- Connect venting valve with G1/8" connecting thread directly.
- Where flange size DN 10-KF is involved, use Adapter PM 033 737-T.

#### Connecting the venting valve

- 4 Venting connection
- 41 Valve control unit
- 42 Venting valve
- 43 Connection hose
- 44 Drying Unit TTV 001

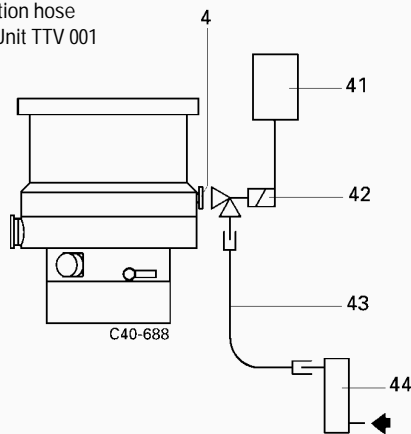

#### Electrical connections, venting valves

Electrical connections should be carried out in accordance with the operating instructions for the respective unit and pertinent electronic drive unit.

### 3.6. Connecting The Electronic Drive Unit



Voltages of >100 V can be present on the open electrical contacts on a running down pump. There is danger of an electrical shock if the contacts are touched.

Disconnect the plug to the electronic drive unit only once the pump is completely at rest and the electronic drive unit has been disconnected from the mains.

- ➔ Plug in connecting cable (accessory) between the electronic drive unit and the turbopump. For details please see the operating instructions for the electronic drive unit.

### 3.7. Connecting The Sealing Gas Valve

Inert sealing gas can be connected to the turbopump to protect the bearing, lubricant and drive. In this case, a sealing gas valve will be required (see "Accessories").

- ➔ Setting the volume of sealing gas (please refer to the operating instructions for the sealing gas valve).
- ➔ Unscrew locking screw from the sealing gas connection of the pump.
- ➔ Screw in sealing gas valve with seal.
- ➔ Remove the protective cap from the sealing gas valve.
- ➔ Flange on hose nipple (DN 16 ISO-KF-10; Accessory).
- ➔ Make hose connection from the pressure reducer to the sealing gas valve.

#### Connecting the sealing gas valve

- 66 Sealing gas valve
- 67 Hose nipple
- 68 Hose connection
- 69 Pressure reducer
- 70 Gas canister

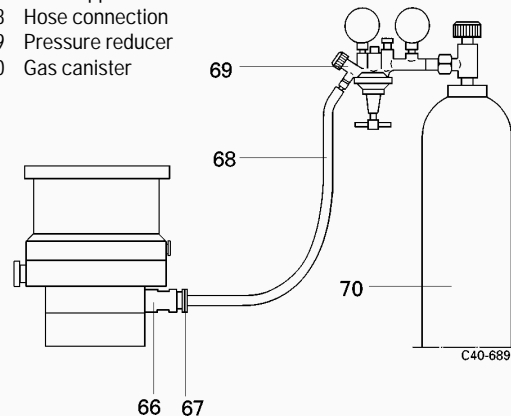

## 4. Operations

### 4.1. Lubricant Filling



Pumps must be filled with lubricant before being operated.  
If possible fill in the lubricant in the fitting position of the pump.

Pumps are designed to operate with Lubricant "TL 011" or "F3" (see rating plate).

For pumps which have been designed to operate with "TL 011" a pack of "TL 011" is supplied with the pump.  
For pumps which have been designed to operate with "F3", no lubricant is supplied with the pump. The lubricant must be ordered separately (see Section 9.1.).



If "F3" is heated above 300 °C, toxic vapours which can harm the airways are given off. Do not allow "F3" to come into contact with tobacco products (danger of poisoning when ignited). The precautions necessary in the handling of chemicals must be observed.



Pumps designed to operate with "TL 011" must not be modified to operate with "F3" and vice versa.

#### Filling the lubricant

- ➔ Unscrew lubricant filler screw and, using the syringe provided, inject approximately 65 cm<sup>3</sup> of lubricant.
- ➔ Screw back in lubricant filler screw with the O-ring.

#### Please note:

If the pump is to be operated in the vertical position, the sight glass should be approximately half full with lubricant.  
If the pump is to be operated in the horizontal position, (fore-vacuum flange pointing down), the sight glass should be filled with lubricant up to the upper edge.

### 4.2. Switching ON



Turbopump rotors rotate at high speed. When the high vacuum flange is open there is a danger of injury and of damage to the pump caused by objects falling into the pump. Therefore never operate the pump with open high vacuum flange.

#### Before switching ON:

- ➔ With water cooling: Open cooling water supply and check flow.
- ➔ If air cooling is connected it is switched on automatically in accordance with Section 3.4.

#### Switching ON:

- ➔ Switch on the turbopump with switch S1 on the electronic drive unit.
- ➔ If a sealing gas valve is involved, open the sealing gas supply. For pressures greater than 1000-1400 mbar check the setting of the sealing gas valve (see sealing gas valve operating instructions).

#### The electronic drive unit switches (schematically)

S1 On/Off switch, turbopump  
S2 On/Off switch, heating  
S3 Reset

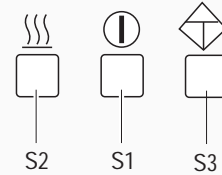

- When Pumping Station Controller TCS 130/603/303/304 is in use, the turbopump, the backing pump and the recycled water cooling unit (if fitted) are started at the same time with switch S1.
- The pump starts running automatically. The time taken to attain the rotation speed switchpoint depends on the electronic drive unit, the size of the vacuum chamber and the backing pump.
- Turbopump heating (if fitted) is switched on by activating switch S2 on the electronic drive unit once the rotation speed switchpoint has been exceeded.

#### Reset

When switching on for the first time or after a lubricant change the contact in the lubricant pump can be opened by the degassification of the lubricant. In such cases the electronic drive unit, as in other malfunction situations, switches off the pump. Re-starting is carried out with switch S3 "Reset" on the electronic drive unit (perhaps several times).

The reset function is activated by:

- Activating switch S3 on the electronic drive unit.
- Removing mains voltage for  $\geq 2$  seconds, for example with switch S1 on the electronic drive unit.
- Activating an externally connected reset switch S6 for  $\geq 2$  seconds.
- Serial Interface RS 232C.



Take care when pumping hazardous gases. Comply with all the gas manufacturer's safety instructions.

### 4.3. Operating Characteristics under Gas Load



Water cooling is required if the pumps are to be operated with gas load.

Without gas load, the turbopump takes up little current at the nominal rotation speed. As the gas load increases, the take-up of current increases up to the maximum value (maximum gas throughput). The maximum gas throughput level is dependent on the pumping speed of the backing pump.

At the nominal rotation speed the turbopump may only be operated up to the maximum gas throughputs (see Section 7. Technical Data).

Where higher throughputs or fore-vacuum pressures are involved, gas friction on the rotor disks cause the permissible operating temperature to be exceeded. With higher gas throughputs it is essential to work with reduced rotation speeds.

If the pressure and the gas throughput are regulated separately, a component to throttle the pumping speed must be fitted. This can be achieved by either pre-switching a conductance value regulator or by using the Electronic Drive Unit TCP 600 with rotation speed regulation (rotation speed setting module option). In the latter case it is sensible to reduce the nominal rotation speed to approximately 50%.

### 4.4. Heating (optional)

Heating turbopumps and vacuum chambers accelerates the attainment of final pressures.

The heating period is dependent on the level of contamination and the required final pressure. Heat for at least four hours.

- ➔ Switch on turbopump heating via switch S2 on the electronic drive unit.



High temperatures are generated when turbopump or vacuum chamber are baked out. Contact with hot parts can cause burns, even when the heating has been switched off.

Heating sleeves, pump casing and vacuum chamber should all be insulated when fitting.

Do not touch heating sleeves, pump casing and vacuum chambers during baking out.



If the vacuum chamber itself is heated the temperature of the high vacuum flange must not exceed 120 °C.

If the vacuum chamber is heated to 200 °C plus, heat radiation shielding must be fitted to the pump rotor.

### 4.5. Circulatory Lubrication

The ball bearing on the fore-vacuum side is supplied with lubricant via the lubricant pump.

The circulation of the lubricant is monitored via a switching contact. If there is insufficient lubricant, the electronic drive unit switches off the turbopump. Monitoring is active only from 45% of the final rotation speed.

If, at a rotation speed of > 45% of the final rotation speed (for example through the degassification of the lubricant), the contact opens for  $\geq 2$  minutes, the electronic drive unit assumes a lubricant deficiency and switches off the turbopump.

- ➔ Check the filling level of the lubricant.
- ➔ Re-start the turbopump with the reset (Switch S3 on the electronic drive unit).

### 4.6. Switching OFF And Venting

To avoid contamination occurring when switching off, the pump should be vented with dry venting gas before shut-down.

- ➔ After a process involving corrosive gas has been completed, continue to operate the turbopump with sealing gas for at least 15 minutes.
- ➔ Close sealing gas supply.
- ➔ Close the vacuum safety valve in the fore-vacuum line.
- ➔ Switch off both turbopump and the electronic drive unit at the same time with switch S1.
- ➔ Open venting screw or venting valve with venting connection (with PFEIFFER venting valves and pertinent control units the turbopump is vented automatically).
- ➔ Shut off water supply.

#### 4.7. Shutting Down For Longer Periods



Vacuum pumps are sometimes used to pump aggressive or hazardous gases. There is a danger of personal injury resulting from coming into contact with process gases. Before removing a turbopump from the system, first:

- Vent the turbopump with a neutral gas or dry air.
- Ensure that there is no residual process gas in the system nor in the feeder lines.

If the turbopump is to be shut down for more than a year:

- ➔ Remove turbopump from the system.
  - ➔ Change the lubricant (see Section 6.1.).
- Please note:** Lubricant TL 011 must no longer be used after **2 years** of non-operations.

- ➔ Close the high vacuum flange and evacuate the turbopump via the fore-vacuum flange.
- ➔ Vent turbopump via the venting connection with nitrogen or dry air.
- ➔ Close fore-vacuum and venting connection by blank flanging.
- ➔ Place the pump vertically on its rubber feet.
- ➔ In rooms with moist or aggressive atmospheres, the turbopump must be air-sealed in a plastic bag together with a bag of desiccant, e.g. silicagel.

**Important:**

If the pump has been shut down for **3 years** a bearing change must be carried out (please get in touch with PFEIFFER Service).

## 5. What To Do In Case Of Breakdowns?

Problem	Possible Causes	Remedy
Pump doesn't start	<ul style="list-style-type: none"> <li>• Power supply interrupted</li> </ul>	<ul style="list-style-type: none"> <li>• Check fuse in the electronic drive unit</li> <li>• Check plug contacts on the pump and the electronic drive unit</li> <li>• Check feeder lines</li> </ul>
Pump doesn't attain nominal rotation speed  Pump cuts out during operations	<ul style="list-style-type: none"> <li>• Fore-vacuum pressure too high</li> <li>• Leak or too much gas</li> <li>• Rotor sluggish caused by defective bearing</li> <li>• The switchpoint in the electronic drive unit TCP is set too high</li> <li>• Thermal overloading caused by               <ul style="list-style-type: none"> <li>- Insufficient water flow</li> <li>- Insufficient air supply</li> <li>- Fore-vacuum pressure too high</li> <li>- Ambient temperature too high</li> </ul> </li> <li>• Leak or too much gas load</li> <li>• Lubricant or lubricant pump dirty</li> <li>• Lubricant deficiency</li> </ul>	<ul style="list-style-type: none"> <li>• Check backing pump function</li> <li>• Check seals</li> <li>• Seek leak and repair</li> <li>• Check bearing (noises ?): Request PFEIFFER Service to replace</li> <li>• Lower the switchpoint</li> <li>• Ensure free flow</li> <li>• Ensure adequate air supply</li> <li>• Reduce fore-vacuum pressure</li> <li>• Reduce ambient temperature</li> <li>• Seek leak in the system and repair</li> <li>• Reduce process gas feed</li> <li>• Carry out lubricant change as per Section 6.1. or clean the lubricant pump as per Section 6.2.</li> <li>• Check lubricant and replace as necessary</li> </ul>
Pump doesn't attain final pressure	<ul style="list-style-type: none"> <li>• Pump dirty</li> <li>• Leak in vacuum chamber, lines or pump</li> </ul>	<ul style="list-style-type: none"> <li>• Bake out pump</li> <li>• If seriously contaminated: Request PFEIFFER Service to clean</li> <li>• Seek leak starting with vacuum chamber</li> <li>• Repair leak</li> </ul>
Unusual operating noises	<ul style="list-style-type: none"> <li>• Bearing damaged</li> <li>• Rotor damaged</li> <li>• Splinter shield (if fitted) not seated firmly</li> </ul>	<ul style="list-style-type: none"> <li>• Inform PFEIFFER Service of need for repair</li> <li>• Inform PFEIFFER Service of need for repair</li> <li>• Check seat of splinter shield (see Section 3.2.)</li> </ul>

## 6. Maintenance

### Important!

No liability for personal injury nor material damage will be accepted for damages and operational interruptions which have been caused by improper maintenance; in addition, all guarantees become invalid.

You can change the lubricant yourself. Your pump can be cleaned on the spot if it is not very dirty. Your local PFEIFFER Service can advise you regarding cleaning procedures and any other maintenance and service work.

### 6.1. Changing The Lubricant

The lubricant should be replaced at least once a year. Where extreme operating conditions or unclean processes are involved, the replacement interval should be checked with your PFEIFFER Service Center.



Drain of and fill in the lubricant in the fitting position if possible. If it is absolutely necessary to dismantle the pump to change the lubricant, this may only be carried out in the position shown in Section 3.2. otherwise the lubricant could contaminate the pump.

- ➔ Switch off the turbopump, vent to atmospheric pressure (see Section 4.6.) and allow to cool as necessary.
- ➔ If necessary, remove the turbopump from the system. The lubricant can be changed in both vertical and horizontal attitudes.
- ➔ Unscrew lubricant drain screw and drain lubricant into a suitable container.
- ➔ Screw back in lubricant drain screw with the O-ring.
- ➔ Unscrew lubricant filler screw. Using the syringe provided inject approximately 65 cm<sup>3</sup> of lubricant as per the rating plate (please see Section 4.1. for the lubricant level).
- ➔ Screw in lubricant filler screw with the O-ring.



Lubricants can contain toxic substances from the medium pumped. Lubricant must be disposed of in accordance with the respective regulations.

### 6.2. Cleaning And Changing The Bearing On The Lubricant Pump

If, following a malfunction, the pump does not accelerate to its operational rotation speed on account of a deficiency in the lubricant, the lubricant pump must be cleaned.

- ➔ Drain lubricant and dispose of as described in Section 6.1.

Detach the lubricant pump as follows and drain the remaining lubricant.

- ➔ Unscrew the four screws 82 and remove flanges 81 and 100.
- ➔ Disconnect plug 83 with connecting cable from the lubricant pump.
- ➔ Using a dismantling mandrel (see "Accessories") force out lubricant pump 77 from the side of flange 100 out of the lubricant reservoir 64 until it is easy to draw it out. Take care not to damage the connecting cable.
- ➔ Clean the lubricant pump and boring in the lubricant reservoir using a clean, fluff-free cloth.
- ➔ Dismantle the lubricant pump in accordance with the following diagram and clean.
- ➔ Force out pin 80 in order to remove floater 79. When re-fitting, the floater head should point to the pin.
- ➔ Check the radial ball bearing 78 for free movement.
- ➔ If the bearing is defective, it should be replaced. Before fitting, the new bearing should be cleaned in pure alcohol and then moistened with lubricant; push onto the shaft manually.
- ➔ Re-assemble lubricant pump; take care with O-ring 74.
- ➔ The groove on the lubricant pump must be positioned in the centering pin in lubricant reservoir 64.
- ➔ Re-fit the flanges 81 and 100.
- ➔ Screw in lubricant drain screw 72 with O-ring 75.
- ➔ Fill in approximately 65 cm<sup>3</sup> of lubricant in accordance with Section 6.1.

Lubricant Pump

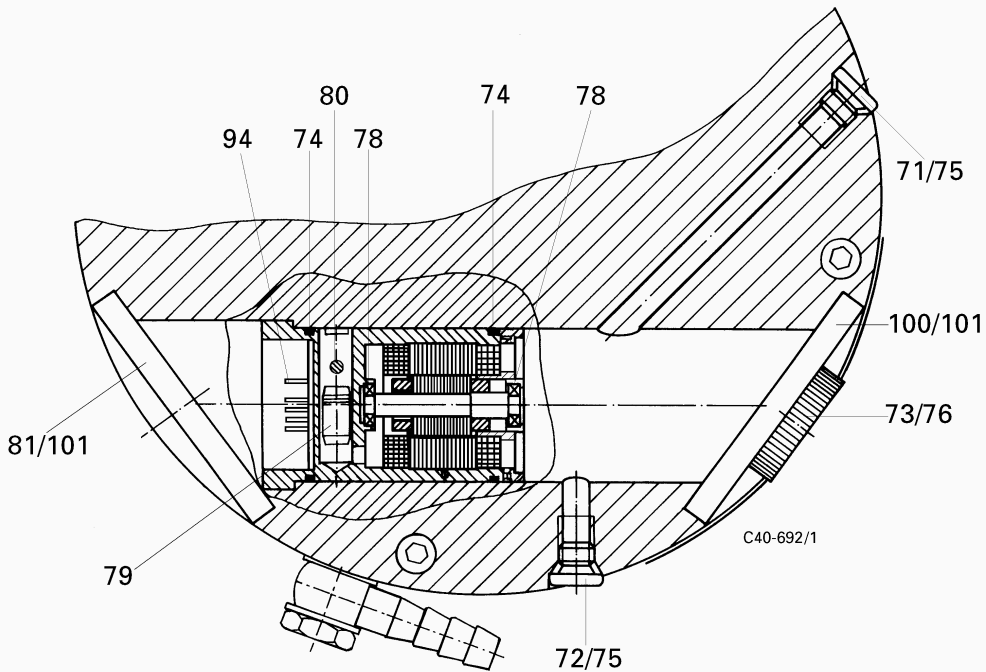
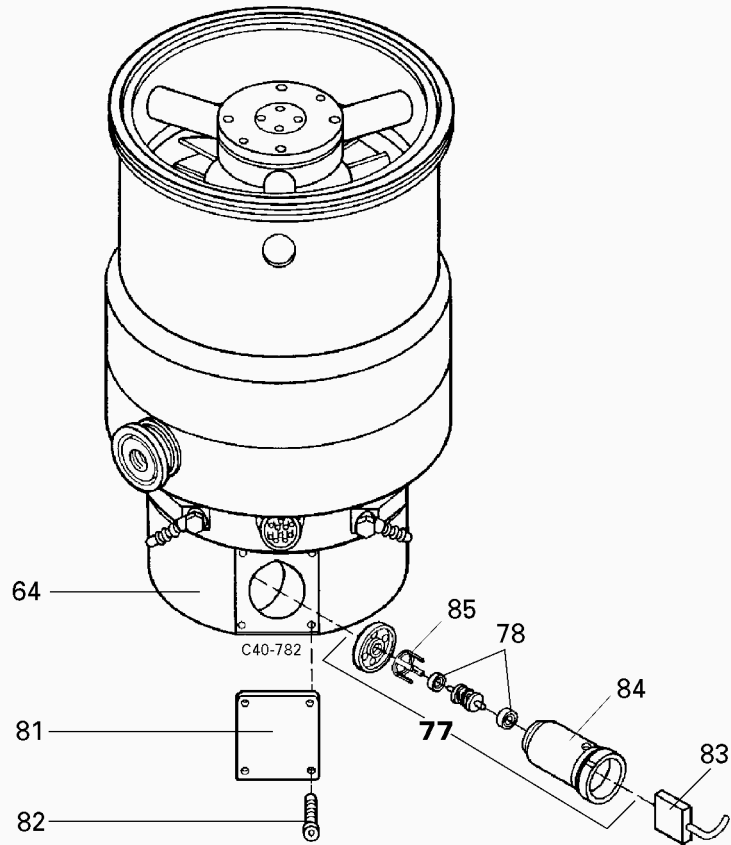

- |                           |                   |
|---------------------------|-------------------|
| 64 Lubricant reservoir    | 80 Pin            |
| 71 Lubricant filler screw | 81 Flange         |
| 72 Lubricant drain screw  | 82 Securing screw |
| 73 Sight glass            | 83 Plug           |
| 74 O-ring                 | 84 Casing         |
| 75 O-ring                 | 85 Cage           |
| 76 O-ring                 | 94 Contact        |
| 77 Lubricant pump         | 100 Flange        |
| 78 Radial ball bearing    | 101 Seal          |
| 79 Floater                |                   |

## 7. Technical Data

Feature	Unit	TMH 1600 TMU 1600		TMH 1600 C TMU 1600 C	
Connection nominal diameter					
Inlet		DN 200 ISO-K DN 200 CF-F	DN 250 ISO-K DN 250 CF-F	DN 200 ISO-K DN 200 CF-F	DN 250 ISO-K DN 250 CF-F
Outlet		DN 40 ISO-KF/G 1/4" G 1/8"		DN 40 ISO-K/G 1/4" G 1/8"	
Venting connection					
Electronic Drive Unit		TCP 380/TCP 600		TCP 600	
Nominal rotation speed	1/min	36 000		36 000	
Stand-by rotation speed	1/min	24 000		24 000	
Run-up time (up to 90% of the nominal rotation speed, fore-vacuum pressure $\leq 0.1$ mbar)	min	21/7		7	
Volum flow rate for					
Nitrogen N <sub>2</sub>	l/s	1100	1500	1100	1500
Helium He	l/s	1320	1450	1320	1450
Hydrogen H <sub>2</sub>	l/s	1050	1150	1050	1150
Argon Ar	l/s	-	-	1050	1400
Tetraflourmethan CF <sub>4</sub>	l/s	-	-	850	1100
Compression ratio for					
N <sub>2</sub>		$> 10^{12}$		$> 10^{12}$	
He		$> 1 \cdot 10^8$		$> 1 \cdot 10^8$	
H <sub>2</sub>		$3 \cdot 10^6$		$3 \cdot 10^6$	
Ar		$> 10^{12}$		$> 10^{12}$	
CF <sub>4</sub>		$> 10^{12}$		$> 10^{12}$	
Maximum fore-vacuum pressure					
N <sub>2</sub>	mbar l/s	12		12	
He	mbar l/s	10		10	
H <sub>2</sub>	mbar l/s	4		4	
Ar	mbar l/s	12		12	
CF <sub>4</sub>	mbar l/s	12		12	
Max. gas throughput					
N <sub>2</sub>	mbar l/s	5 <sup>1)</sup> (10)		17 <sup>2)</sup> (10)	
He	mbar l/s	5 <sup>1)</sup> (14)		-	
H <sub>2</sub>	mbar l/s	4 <sup>1)</sup> (17)		-	
Ar	mbar l/s	-		14,5 <sup>2)</sup> (5,5)	
CF <sub>4</sub>	mbar l/s	-		15 <sup>2)</sup> (8)	
Recommended backing pump					
Rotary vane pump		DUO 010 M		DUO 010 M	
Diaphragm vacuum pump		MD 4T		MD 4TC	
Dry three stage backing pump		UniDry <sup>TM</sup>		UniDry <sup>TM</sup>	
Final pressure with					
DUO 010 M	mbar	$< 1 \cdot 10^{-10}$		$< 1 \cdot 10^{-10}$	
MD 4T/MD 4TC	mbar	$< 1 \cdot 10^{-10}$		$< 1 \cdot 10^{-10}$	
UniDry <sup>TM</sup>	mbar	$< 1 \cdot 10^{-10}$		$< 1 \cdot 10^{-10}$	
Lubricant					
Type <sup>3)</sup>		TL 011 or F3		F3	
Filling volume	cm <sup>3</sup>	65		65	
Max. cooling water consumption with water at 15°C <sup>4)</sup>	l/h	100		100	
Cooling water temperature	°C	5 - 25		5 - 25	
Permissible ambient temperature with air cooling	°C	0 - 35		not permissible	
Permissible magnetic field	mT	3		3	
Heating power consumption	W	170		170	
Weight	kg	49/51	51/53	51	51/53
Noise level	dB (A)	< 47		< 47	

- 1) Measured with a rotary vane pump 1.5 m<sup>3</sup>/h; Values in brackets with a backing pump > 5 m<sup>3</sup>/h.
- 2) With a backing pump 16 m<sup>3</sup>/h in standby operations; values in brackets at nominal rotation speed.
- 3) See rating plate.
- 4) With maximum gas throughput.

### 7.1. Dimensions

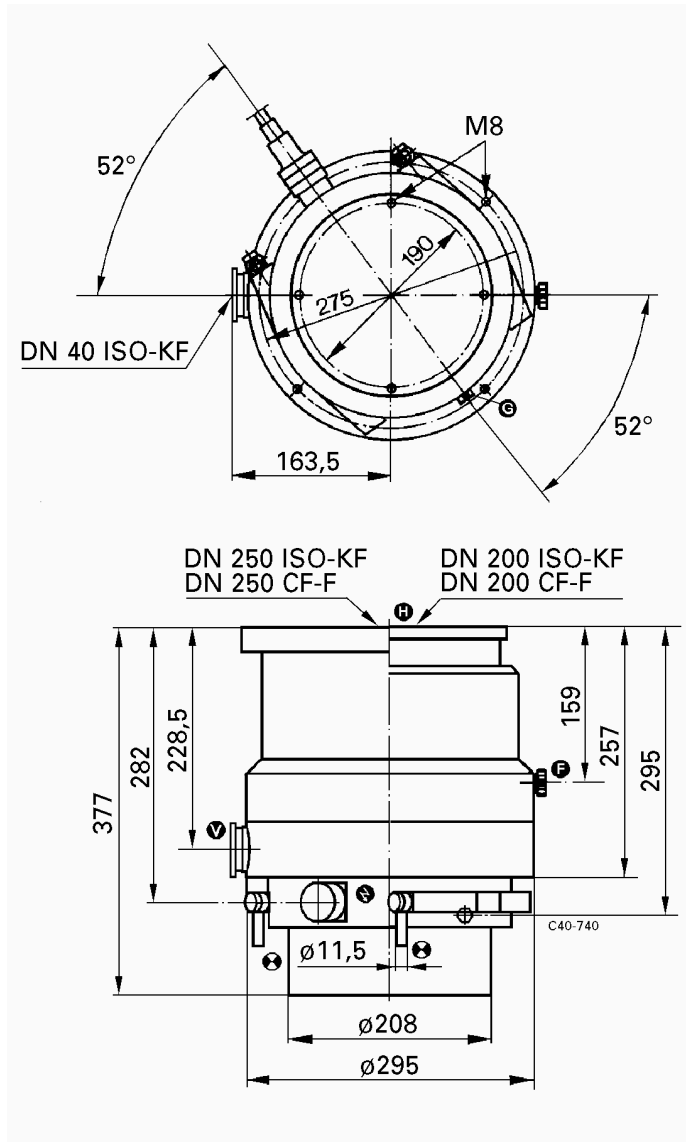

## 8. Service

### Do Make Use Of Our Service Facilities

In the event that repairs are necessary a number of options are available to you to ensure any system down time is kept to a minimum:

- Have the pump repaired on the spot by our PFEIFFER Service Engineers;
- Return the pump to the manufacturer for repairs;
- Replace with a new value pump.

Local PFEIFFER representatives can provide full details.

### Before Returning:

- ➔ Please attach a clearly visible notice "Free of harmful substances" (both on the unit and also on the delivery note and any accompanying letters).

"Harmful substances" are substances and preparations as defined in the current, local, dangerous substances regulations; in the U.S.A. as

"materials in accordance with the Code of Federal Regulations (CFR) 49 Part 173.240 Definition and Preparation".

We will carry out the decontamination and invoice this work to you if you have not attached this note. This also applies where the operator does not have the facilities to carry out the decontamination work. Units which are contaminated microbiologically, explosively or radioactively cannot be accepted as a matter of principle.

### Fill Out The Declaration Of Contamination

- ➔ In every case the "Declaration of Contamination" must be completed diligently and truthfully.
- ➔ A copy of the completed declaration must accompany the unit; any additional copies must be sent to your local PFEIFFER Service Center.

Please get in touch with your local PFEIFFER representatives if there are any questions regarding contamination.



Decontaminate units before returning or possible disposal. Do not return any units which are microbiologically, explosively or radioactively contaminated.

### Returning Contaminated Units

If contaminated have to be returned for maintenance/repair, the following instructions concerning shipping must be followed:

- ➔ Neutralise the pump by flushing with nitrogen or dry air.
- ➔ Seal all openings to the air.
- ➔ Seal pump or unit in suitable protective foil.
- ➔ Ship units only in appropriate transport containers.

### Please Note:

Repair orders are carried out according to our general conditions of sale and supply. If repairs are necessary, please send the pump to your nearest PFEIFFER Service Center.

### Contact Addresses And Telephone Hotline

Contact addresses and telephone numbers can be found on the back cover of these operating instructions.



## 9.1. Lubricant

Lubricant	Amount	Order Number
TL 011	0,25 l	PM 006 034 AT
	0,5 l	PM 006 032 AT
	1 l	PM 006 033 AT
F3	0,05 l	PM 006 336 -T
	0,25 l	PM 006 313 -T

## 10. Spare Parts

Pos.	Description	Pieces	Size	Number	Comments	Ordering Quantity
	<b>Spare parts TMH/TMU 1600</b> <b>TMH/TMU 1600 C</b> Set of sealsz	1		PM 053 460 -T		
16	USIT-ring	4	MS-NBR U 12,7/18x1,5	P 3529 142		
17	QUAD-ring	1	VI 10,82x1,78	P 4081 630 C		
71	Lubricant filler screw	1		N 3191 382 X		
72	Lubricant drain screw	1		N 3191 382 X		
73	Sight glass	1		PM 003 251		
74	O-ring	2	36 x 2	P 4070 594 PV		
75	O-ring	2	6 x 2,2	P 4070 088 PV		
76	O-ring	2	22 x 3	P 4070 384 PV		
77	Lubricant pump	1	(for F3)	PM 053 530 -U		
77	Lubricant pump	1	(for TL 011)	PM 043 790 -U		
78	Radial ball bearing	2	5/11 x 3	P 4009 212 DB		
79	Floater	1		PM 033 306 -X		
87	O-ring	1	44 x 3	P 4070 703 PV		
101	O-ring	2	59 x 3	P 4070 874 PV		
	Spare parts pack 1 (bearing change)	1	(for F3)	PM 588 010 -T		
	Spare parts pack 1 (bearing change)	1	(for TL 011)	PM 578 010 -T		
	<b>Spare parts, air cooling</b> <b>only for the TMH/TMU 1600</b> Air cooling set	1	115/230 V 50/60 Hz	PM Z01 225		
36	Fan	2	115/230 V	P 5099 251 R1		
36a	Finger protector	4		P 5099 251 Z4		
36b	Buffer	8	10 x 10 B M4/10	P 0991 099		

When ordering accessories and spare parts please be sure to state the full part number. When ordering spare parts please state additionally the unit type and unit number (see rating plate). Please use this list as an order form (by taking a copy).

Spare parts

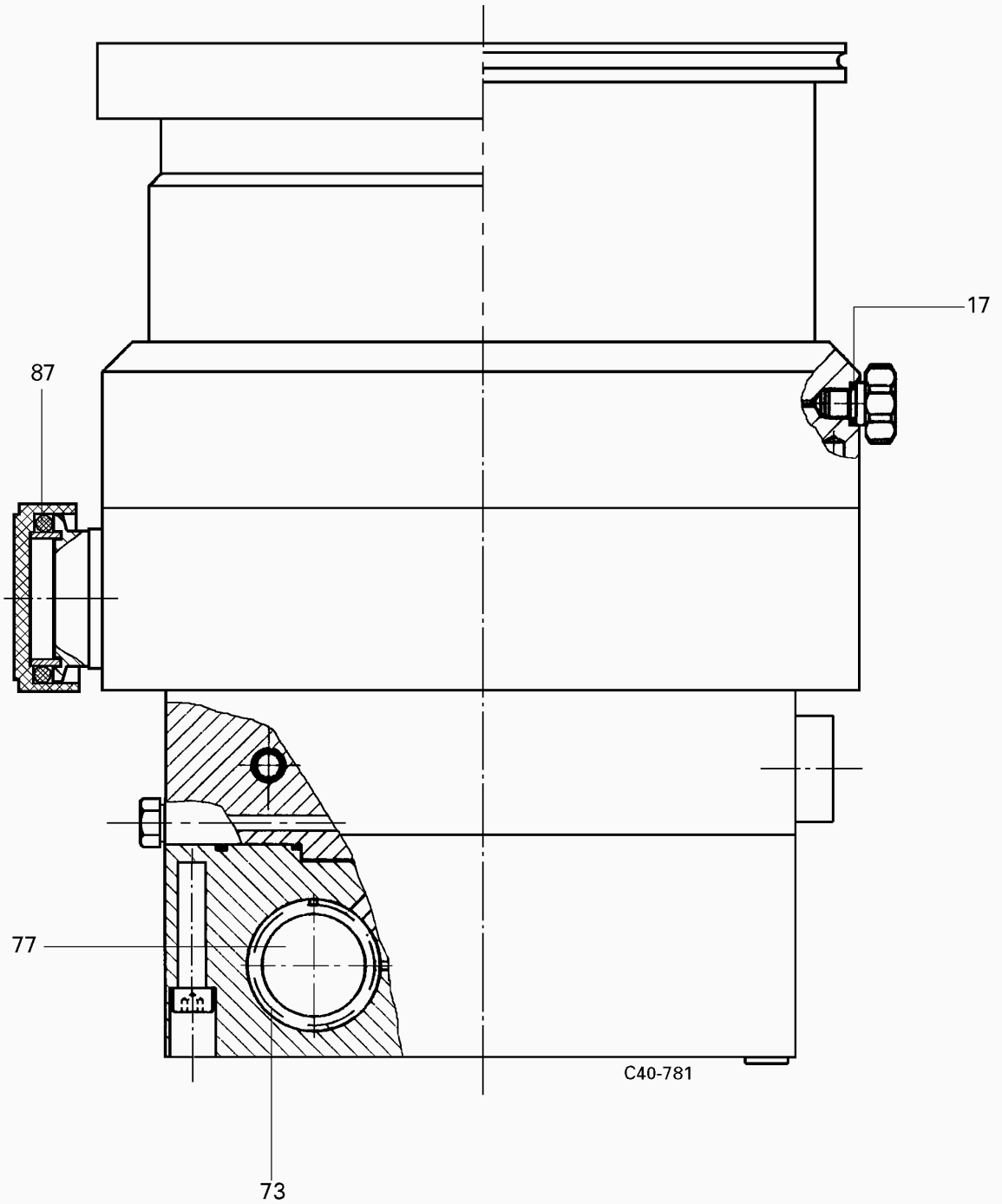

Spare parts

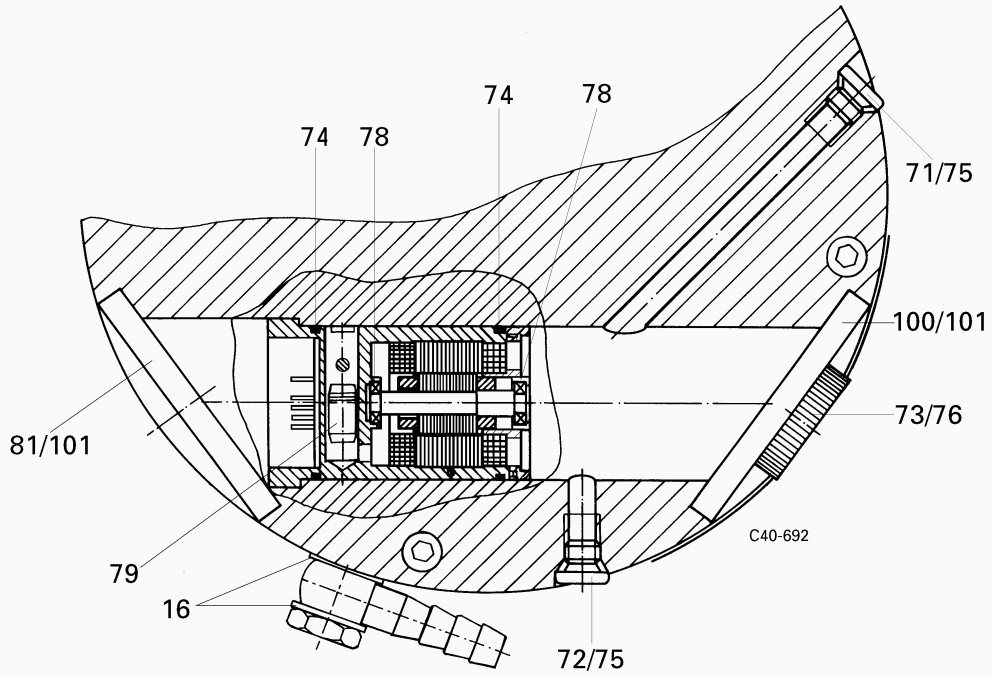

Spare parts, air cooling

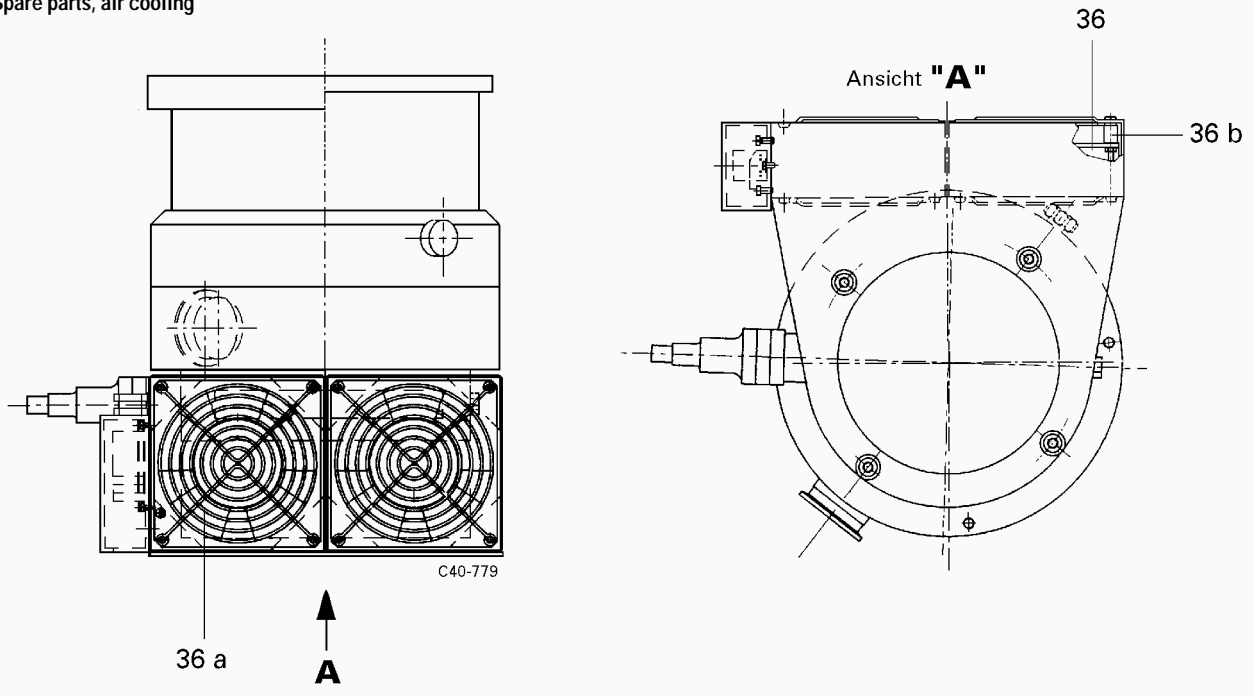

## Declaration of Contamination of Vacuum Equipment and Components

The repair and/or service of vacuum components will only be carried out if a correctly completed declaration has been submitted. Non-completion will result in delay.

The manufacturer could refuse to accept any equipment without a declaration.

**This declaration can only be completed and signed by authorised and qualified staff:**

**1. Description of component:**

- Equipment type/model: \_\_\_\_\_
- Code No.: \_\_\_\_\_
- Serial No.: \_\_\_\_\_
- Invoice No.: \_\_\_\_\_
- Delivery Date: \_\_\_\_\_

**2. Reason for return:**

\_\_\_\_\_

\_\_\_\_\_

\_\_\_\_\_

\_\_\_\_\_

**3. Equipment condition**

- Has the equipment been used?  
yes  no
- What type of pump oil was used?  
\_\_\_\_\_
- Is the equipment free from potentially harmful substances?  
yes  (go to section 5)  
no  (go to section 4)

**4. Process related contamination of equipment**

- toxic yes  no
- corrosive yes  no
- microbiological hazard\*) yes  no
- explosive\*) yes  no
- radioactive\*) yes  no
- other harmful substances yes  no

\*) We will not accept delivery of any equipment that has been radioactively or microbiologically contaminated without written evidence of decontamination!

Please list all substances, gases and by-products which may have come into contact with the equipment:

Tradename Product name Manufacturer	Chemical name (or Symbol)	Danger class	Precautions associated with substance	Action if spillage or human contact
1.				
2.				
3.				
4.				
5.				

### 5. Legally Binding Declaration

I hereby declare that the information supplied on this form is complete and accurate. The despatch of equipment will be in accordance with the appropriate regulations covering Packaging, Transportation and Labelling of Dangerous Substances.

Name of Organisation: \_\_\_\_\_

Address: \_\_\_\_\_ Post code: \_\_\_\_\_

Tel.: \_\_\_\_\_

Fax: \_\_\_\_\_ Telex: \_\_\_\_\_

Name: \_\_\_\_\_

Job title: \_\_\_\_\_

Date: \_\_\_\_\_ Company stamp: \_\_\_\_\_

Legally binding signature: \_\_\_\_\_

⇒ **DE, AT**

**Herstellereklärung im Sinne folgender EU-Richtlinien:**

- Maschinen 89/392/EWG
- Elektromagnetische Verträglichkeit 89/336/EWG
- Niederspannung 73/23/EWG

Hiermit erklären wir, daß das unten aufgeführte Produkt zum Einbau in eine Maschine bestimmt ist und daß deren Inbetriebnahme so lange untersagt ist, bis festgestellt wurde, daß das Endprodukt den Bestimmungen der EU-Richtlinie 89/392/EWG, Anhang II B entspricht.

Wir bestätigen Konformität mit der EU-Richtlinie über elektromagnetische Verträglichkeit 89/336/EWG und der EU-Niederspannungsrichtlinie 73/23/EWG. Die angewandten Richtlinien, harmonisierten Normen, nationalen Normen und Spezifikationen sind unten aufgeführt.

⇒ **GB, IE**

**Manufacturer's declaration pursuant to the following EU directives:**

- Machinery Directive 89/392/EEC
- Electromagnetic Compatibility Directive 89/336/EEC
- Low Voltage Directive 73/23/EEC

We hereby certify that the product specified below is intended for installation in a machine which is forbidden to be put into operation until such time as it has been determined that the end product is in accordance with the provision of EU Directive 89/392/EEC, Annex II B.

We certify conformity with EU Electromagnetic Compatibility Directive 89/336/EEC and EU Low Voltage Directive 73/23/EEC.

The guidelines, harmonized standards, national standards and specifications which have been applied are listed below.

⇒ **BE, FR**

**Déclaration du constructeur conformément aux directives CE suivantes:**

- directive machine CE 89/392/CEE
- directive CE 89/336/CEE concernant la compatibilité électromagnétique
- directive CE 73/23/CEE concernant la basse tension

Nous déclarons par la présente que le produit mentionné ci-dessous est prévu pour le montage sur une machine et que sa mise en service est interdite tant qu'il n'a pas été déterminé que le produit final répond bien aux dispositions de la directive CE 89/392/CEE, appendice II B.

Nous confirmons la conformité du produit avec la directive CE 89/336/CEE concernant la compatibilité électromagnétique et la directive CE 73/23/CEE concernant la basse tension. Les directives appliquées, normes harmonisées et les normes et spécifications nationales appliquées figurent ci-dessous.

⇒ **IT**

**Dichiarazione del costruttore ai sensi delle seguenti direttive UE:**

- Macchinari 89/392/CEE
- Compatibilità elettromagnetica 89/336/CEE
- Bassa tensione 73/23/CEE

Si dichiara che il prodotto qui menzionato è destinato al montaggio in una macchina e che la sua messa in funzione è vietata sin quando non è stato accertato che il prodotto finale non rispetta le disposizioni della direttiva UE 89/392/CEE, Appendice II B.

Attestiamo la conformità con la direttiva UE sulla compatibilità elettromagnetica 89/336/CEE e la direttiva UE sulla bassa tensione 73/23/CEE.

Sono riportate in basso le direttive applicate, le norme standardizzate nonché le norme e le specifiche nazionali utilizzate.

⇒ **ES**

**Declaración del fabricante al tenor de las siguientes Directivas de la UE:**

- Maquinarias 89/392/MCE
- Compatibilidad Electromagnética 89/336/MCE
- Baja Tensión 73/23/MCE

Por la presente declaramos que el producto mencionado más abajo está previsto para ser incorporado en una máquina y que la puesta en servicio de la misma queda prohibida en tanto que no se haya verificado que el producto final concuerda con las disposiciones resultantes de la Directiva 89/392/MCE de la UE, Apéndice II B.

De nuestra parte certificamos la conformidad con la Directiva 89/336/MCE de la UE sobre Compatibilidad Electromagnética y la Directiva 73/23/MCE de la UE sobre Baja Tensión.

Las directivas aplicadas, normas armonizadas y las normas y especificaciones nacionales aplicadas se mencionan abajo.

⇒ **NL**

**Verklaring van de fabrikant in de zin van de volgende EU-richtlijnen:**

- machinerichtlijn 89/392/EEG
- richtlijn over elektromagnetische compatibiliteit 89/336/EEG
- richtlijn over laagspanning 73/23/EEG

Hiermee verklaren wij dat het hieronder genoemde product is bedoeld om te worden ingebouwd in een machine en dat de ingebruikneming hiervan zolang verboden is, totdat is vastgesteld dat het eindproduct voldoet aan de bepalingen van EU-richtlijn 89/392/EEG, appendix II B.

Wij bevestigen de conformiteit met de EU-richtlijn over elektromagnetische compatibiliteit 89/336/EEG en de EEG-richtlijn over laagspanning 73/23/EEG

De toegepaste richtlijnen, geharmoniseerde normen en de toegepaste nationale normen en specificaties zijn hierna aangegeven.

⇒ **DK**

**Producenterklæring i henhold til følgende EU-direktiver:**

- Maskiner 89/392/EWG
- Elektromagnetisk kompatibilitet 89/336/EWG
- Lavspænding 73/23/EWG

Hermed erklærer vi, at det nedenstående produkt er beregnet til indbygning i en maskine og at dennes idriftsættelse er forbudt, indtil det er fastslået, at slutproduktet er i overensstemmelse med EU-direktiv 89/392/EWG tillæg II B.

Vi attesterer konformitet med EU-direktiv vedrørende elektromagnetisk kompatibilitet 89/336/EWG og med EU-lavspændingsdirektiv 73/23/EWG.

De anvendte direktiver, harmoniserede standarder og de anvendte nationale standarder og specifikationer er angivet nedenfor.



### Tillverkarens förklaring enligt följande EG-direktiv:

- Maskindirektiv 89/392/EEC
- Elektromagnetisk tolerans 89/336/EEC
- Lågspänning 73/23/EEC

Härmed förklarar vi, att den nedan nämnda produkten är avsedd för inmontering i en maskin och att denna maskin inte får tas i drift förrän det har konstaterats, att slutprodukten stämmer överens med EG's direktiv 89/392/EEC, annex II B.

Vi bekräftar konformitet med EG's-direktiv om elektromagnetisk tolerans 89/336/EEC och EG's lågspänningsdirektiv 73/23/EEC.

De riktlinjer, anpassade standarder, nationella standarder och specifikationer som har blivit accepterade, anges här nedan.



### Valmistajan vakuutus seuraavien EU-direktiivien mukaisesti:

- konedirektiivi 89/392/ETY
- sähkömagneettinen siedettävyyss 89/336/ETY
- pienjännite 73/23/ETY

Vakuutamme täten, että allamainittu tuote on tarkoitettu asennettavaksi koneeseen ja sen käyttöönotto on kielletty kunnes on todettu, että lopullinen tuote vastaa EU-direktiivin 89/392/ETY vaatimuksia.

Vahvistamme vaatimustenmukaisuuden EU-direktiivin sähkömagneettinen siedettävyyss 89/336/ETY ja EU-pienjännitedirektiivin 73/23/ETY kanssa.

Soveltamamme suuntaviitat, harmonisoidut standardit, kansalliset standardit ja rakennemääräykset on lueteltu alempana.



### Declaração do fabricante, de acordo com as seguintes Directivas CE:

- Máquinas, na redacção 89/392/CEE
- Compatibilidade electromagnética, na redacção 89/336/CEE
- Baixa tensão, na redacção 73/23/CEE

Com a presente, declaramos que o produto abaixo indicado se destina à montagem numa máquina e que é proibida a colocação em serviço da mesma antes de se ter declarado, que o produto final está em conformidade com o disposto na Directiva CE, na redacção 89/392/CEE, Apêndice II B.

Certificamos haver conformidade com o disposto na Directiva CE sobre compatibilidade electromagnética, na redacção 89/336/CEE, e o disposto na Directiva CE sobre baixa tensão, na redacção 73/23/CEE.

Abaixo, dá-se indicação das directivas aplicadas, das normas harmonizadas e das normas e especificações aplicadas no respectivo país.



Δήλωση κατασκευαστή κατά το νόημα των εχής οδηγιών της ΕΕ:

- περί μηχανών 89/392/Ε.Ο.Κ.
- περί ηλεκτρομαγνητικής συμβατότητας 89/336/Ε.Ο.Κ.
- περί χαμηλής τάσης 73/23/Ε.Ο.Κ.

Με την παρούσα δήλωση βεβαιώνουμε ότι το κατωτέρω αναφερόμενο προϊόν προορίζεται για την προσαρμογή σε μία άλλη μηχανή, και ότι η έναρξη λειτουργίας της απαγορεύεται μέχρις ότου διαπιστωθεί, ότι το συνολικό συγκρότημα ανταποκρίνεται στους ισχύοντες κανονισμούς της οδηγίας της Ε.Ε. 89/392/Ε.Ο.Κ., παράρτημα II Β.

Οι εφαρμοσθέντες κανονισμοί, οι εναρμονισμένες προδιαγραφές και οι εφαρμοσθείσες εθνικές προδιαγραφές και τεχνικές προδιαγραφές αναφέρονται κατωτέρω:

Produkt/Product/Produit/Prodotto/Producto/Produkt/Produkt/Producto/ Προϊόν:

TMH/TMU 1600

TMH/TMU 1600 C

Angewendete Richtlinien, harmonisierte Normen und angewendete, nationale Normen in Sprachen und Spezifikationen:

Guidelines, harmonised standards, national standards in languages and specifications which have been applied:

Les directives appliquées, normes harmonisées et les normes nationales appliquées en langues et spécifications:

Direttive applicate, norme standardizzate e norme nazionali utilizzate in lingue e specifiche:

Directivas aplicadas, normas armonizadas y normas nacionales aplicadas en idiomas y especificaciones:

Toegepaste richtlijnen, geharmoniseerde normen en toegepaste nationale normen met betrekking tot talen en specificaties:

Anvendte direktiver, harmoniserede standarder og de anvendte nationale standarder med sprog og specifikationer:

Directivas aplicadas, normas harmonizadas e normas aplicadas na linguagem e nas especificações do respectivo país:

Εφαρμοσθέντες κανονισμοί, εναρμονισμένες προδιαγραφές και εφαρμοσθείσες εθνικές προδιαγραφές σε γλώσσες και τεχνικές προδιαγραφές:

EN 292-1

EN 61 010

EN 292-2

EN 1012-2

EN 294

Unterschriften/Signatures/Signature/Firme/Firmas/Handtekening/Underskrifter/Underskrift/ Allekirjoitukset/Assinaturas/ Υπογραφές:

Geschäftsführer (W. Dondorf)

Managing Director

Gérant d'affaires

Gerente

Διευθύνων Σύμβουλος

Administrerende Direktör

Verkställande Direktör

Directeur

**Zentrale/Headquarters**

Pfeiffer Vacuum GmbH

Emmeliusstrasse 33  
D-35614 Asslar

Telefon 06441/802-0

Telefax 06441/802-202

Hotline 06441/802-333

Internet:

<http://www.pfeiffer-vacuum.de>**Argentina**ARO S.A., Casilla de Correo 4890,  
1000 Buenos Aires, telephone 0054 / 1 331 3918,  
telefax 0054 / 1 331 3572**Australia**Balzers Australia Pty. Ltd., Level 1,  
3, Northcliff Street, Milsons Point, NSW 2061,  
telephone 0061 / 2 9954 1925, telefax 0061 / 2 9954 1939**Austria**Pfeiffer Vacuum Austria GmbH  
Diefenbachgasse 35, A-1150 Wien,  
telephone 0043 / 1 8941 704, telefax 0043 / 1 8941 707  
Service Hotline: 0043 / 1 8941704**Belgium / Luxembourg**Pfeiffer Vacuum Belgium N.V./S.A.  
Minervastraat 14, B-1930 Zaventem  
telephone 0032 / 2 725 0525, telefax 0032 / 2 725 0873  
Service Hotline: 0032 / 2 725 3545**Brazil**Elmi Tec  
Assistencia Técnica e Representação S/C Ltda.  
Rua Bernadino de Compos, 551  
CEP 04620-002 São Paulo, SP - Brasil  
telephone 0055 / 11 532 0740  
telefax 0055 / 11 535 3598**Chile**BERMAT S.A., Coyancura 2283, piso 6  
Providencia, P.O. Box 9781, Santiago  
telephone 0056 / 2 231 8877,  
telefax 0056 / 2 231 4294**Colombia**Arotec Colombiana S.A., Carrera 15 No.38-17  
P.O. Box 050 862, Santafe de Bogota / D.C.  
telephone 0057 / 1 288 7799, telefax 0057 / 1 285 3604**Denmark**Pfeiffer Vacuum Scandinavia AB, Vesterengen 2,  
DK-2630 Taastrup, telephone 0045 / 43 52 38 00,  
telefax 0045 / 43 52 38 50**France**Pfeiffer Vacuum France SAS  
47, rue d'Arthelon, BP 18 F-92190 Meudon Cedex  
telephone 0033 / 1 4623 7070, telefax 0033 / 1 4534 4441**Germany**Pfeiffer Vacuum Vertriebs GmbH,  
Emmeliusstrasse 33, D-35614 Asslar  
telephone 0049 / 6441 802 400  
telefax 0049 / 6441 802 399  
Service Hotline: 0049 / 6441 802 333**Great Britain**Pfeiffer Vacuum Ltd.  
Bradbourne Drive, Tilbrook,  
Milton Keynes, MK7 8AZ, United Kingdom  
telephone 0044 / 1 908 373 333  
telefax 0044 / 1 908 377 776**Greece**Analytical Instruments S.A., 1 Mantzarou St.,  
GR-15451 Athens,  
telephone 0030 / 1 674 8973, telefax 0030 / 1 674 8978**India**Pfeiffer Vacuum India Ltd.  
25-E Nicholson Road, Tarbund  
Secunderabad 500 009,  
telephone 0091 / 40 775 0014, telefax 0091 / 40 775 7774**Israel**Eastronics Ltd., 11 Rozanis Street, P.O. Box 39 300,  
Tel Aviv 61392,  
telephone 00972 / 3 6458 777,  
telefax 00972 / 3 6458 666**Italy**Pfeiffer Vacuum Italia S.p.a.  
Via San Martino, 44 I-20017 RHO (Milano)  
telephone 0039 / 2 93 99 051, telefax 0039 / 2 93 99 05 33**Japan**Hakuto Co. Ltd., C.P.O. Box 25,  
Vacuum & Scientific Instruments Division  
Tokyo Central 100-91,  
telephone 0081 / 3 32 258 910,  
telefax 0081 / 3 32 259 009**Korea**Pfeiffer Vacuum Korea Ltd., 3F Haein Building 453,  
Dokok-Dong, Kang Nam-Ku, Seoul, 135-270  
telephone 0082 / 2 3461 0671,  
telefax 0082 / 2 3461 0676**Netherlands**Pfeiffer Vacuum Nederland BV  
Veldzigt 30a, NL-3454 PW De Meern,  
telephone 0031 / 30 6666050, telefax 0031 / 30 6662794**Peru**Ing. E. Brammert S.C.R.L., José Pardo 182,  
Apartado 173, PE-18 Miraflores,  
telephone 0051 / 1 445 8178  
telefax 0051 / 1 445-1931**Poland**Softrade Sp.z.o.o, ul. Malwowa 35,  
PL-60-175 Poznan, telephone 0048 / 61 8677 168,  
telefax 0048 / 61 8677 111**Portugal**Unilaser Lda, Taguspark  
Núcleo Central, sala nº 268, Estrada Cacém-  
Porto Salvo, P-2780 Oeiras  
telephone 00351 / 1 421 7733,  
telefax 00351 / 1 421 7744**Singapore**APP Systems Services Pte. Ltd, 2 Corporation Road  
06-14 Corporation Place, Singapore 618494,  
telephone 0065 / 268 2024, telefax 0065 / 268 6621**Spain**Tecnovac  
Tecnologia de Vacío S.L., Ronda de Poniente, 6 Bajo F  
Centro Empresarial Euronova  
E-28760 Tres Cantos (Madrid)  
telephone 0034 / 91 804 11 34,  
telefax 0034 / 91 804 30 91**Sweden**Pfeiffer Vacuum Scandinavia AB  
Magasinsgatan 35, Box 10412  
S-43424 Kungsbacka  
telephone 0046 / 300 710 80  
telefax 0046 / 300 172 85  
Service Hotline: 0046 / 300 710 85**Switzerland**Pfeiffer Vacuum Schweiz S.A.  
Förrlibuckstraße 30, CH-8005 Zürich  
telephone 0041 / 1 444 2255,  
telefax 0041 / 1 444 2266  
Service Hotline: 0041 / 1 2730119**South Africa**Labotec Pty Ltd., P.O. Box 6553,  
Halfway House  
1685 Midrand  
telephone 0027 / 11 315 5434,  
telefax 0027 / 11 315 5882**Taiwan**Heli-Ocean Engineering and Trading Co., Ltd.  
6th Floor, No. 67, Shyr Pin Road,  
Hsinchu 300, Taiwan R.O.C.,  
telephone 00886 / 3 5725 848, telefax 00886 / 3 5725 849**Thailand**Thai Unique Co. Ltd., 80-82 Prachathipathai Road,  
Bangkok 10200,  
telephone 00662 / 282 97 49, telefax 00662 / 280 1788**U.S.A.**Pfeiffer Vacuum Technology, Inc.  
24 Trafalgar Square  
Nashua, NH 03063-1988  
USA  
telephon 001/ 603 578 6500  
telefax 001/ 603 578 6550**Venezuela**Secotec S.A., Apartado 3452, Caracas 1010-A,  
telephone 0058 / 2 573 8687  
telefax 0058 / 2 573 1932**Other countries**AVI - Applied Vacuum Industries GmbH  
Leginglenstrasse 17A; CH-7320 Sargans  
Switzerland

telephon 0041 / 81 710 03 80

telefax 0041 81 710 03 81

**Scope of represented countries**Armenia, Azerbaijan, Bangladesh, Belarus, Bulgaria,  
Cambodia, Estonia, Georgia, Hong Kong, Kazakhstan,  
Kingdom of Nepal, Kirghizia, Latvia, Lithuania,  
Maldavia, Philippines, P.R. China, Rumania, Russia,  
Tajikistan, Turkmenistan, Ukraine, Uzbekistan, Vietnam**A.E.M.S.**Advanced Equipment Materials and Systems  
P.O. Box 25  
Föhrenweg 18

FL-9496 Balzers

telephon 0041 / 75 380 0550

telefax 0041 / 75 380 0551

**Scope of represented countries**Bahrain, Egypt, Iraq, Jordan, Kuwait, Lebanon,  
Lybia, Oman, Pakistan, Saudi-Arabia, Sudan, Syria,  
Turkey, United Arab Emirates, Yemen