

# marantz®

## Model MA-9S1 User Guide

---

Monaural Power Amplifier

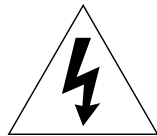
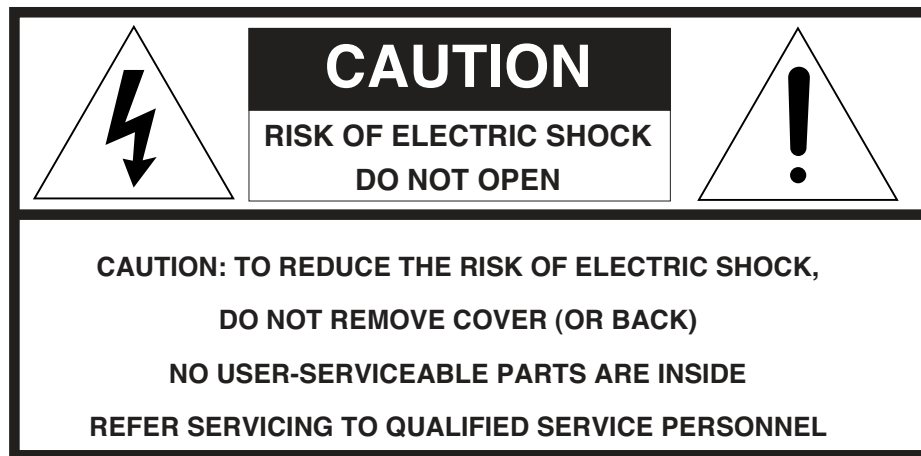

The lightning flash with arrowhead symbol within an equilateral triangle is intended to alert the user to the presence of uninsulated “dangerous voltage” within the product’s enclosure that may be of sufficient magnitude to constitute a risk of electric shock to persons.



The exclamation point within an equilateral triangle is intended to alert the user to the presence of important operating and maintenance (servicing) instructions in the literature accompanying the product.

## WARNING

**TO REDUCE THE RISK OF FIRE OR ELECTRIC SHOCK,  
DO NOT EXPOSE THIS PRODUCT TO RAIN OR MOISTURE.**

**CAUTION: TO PREVENT ELECTRIC SHOCK, MATCH THE  
WIDE BLADE OF THE PLUG TO THE WIDE SLOT, AND  
FULLY INSERT.**

# IMPORTANT SAFETY INSTRUCTIONS

## READ BEFORE OPERATING EQUIPMENT

This product was designed and manufactured to meet strict quality and safety standards. There are, however, some installation and operation precautions which you should be particularly aware of.

1. Read Instructions – All the safety and operating instructions should be read before the product is operated.
2. Retain Instructions – The safety and operating instructions should be retained for future reference.
3. Heed Warnings – All warnings on the product and in the operating instructions should be adhered to.
4. Follow Instructions – All operating and use instructions should be followed.
5. Cleaning – Unplug this product from the wall outlet before cleaning. Do not use liquid cleaners or aerosol cleaners. Use a damp cloth for cleaning.
6. Attachments – Do not use attachments not recommended by the product manufacturer as they may cause hazards.
7. Water and Moisture – Do not use this product near water-for example, near a bath tub, wash bowl, kitchen sink, or laundry tub, in a wet basement, or near a swimming pool, and the like.
8. Accessories – Do not place this product on an unstable cart, stand, tripod, bracket, or table. The product may fall, causing serious injury to a child or adult, and serious damage to the product. Use only with a cart, stand, tripod, bracket, or table recommended by the manufacturer, or sold with the product. Any mounting of the product should follow the manufacturer's instructions, and should use a mounting accessory recommended by the manufacturer.
9. A product and cart combination should be moved with care. Quick stops, excessive force, and uneven surfaces may cause the product and cart combination to overturn.



10. Ventilation – Slots and openings in the cabinet are provided for ventilation and to ensure reliable operation of the product and to protect it from overheating, and these openings must not be blocked or covered. The openings should never be blocked by placing the product on a bed, sofa, rug, or other similar surface. This product should not be placed in a built-in installation such as a bookcase or rack unless proper ventilation is provided or the manufacturer's instructions have been adhered to.
11. Power Sources – This product should be operated only from the type of power source indicated on the marking label. If you are not sure of the type of power supply in your home, consult your product dealer or local power company. For products intended to operate from battery power, or other sources, refer to the operating instructions.
12. Do not defeat the safety purpose of the polarized or grounding-type plug. A polarized plug has two blades with one wider than the other. A grounding type plug has two blades and a third grounding prong. The wide blade of the third prong is provided for your safety. If the provided plug does not fit into your outlet, consult an electrician for replacement of the obsolete outlet.

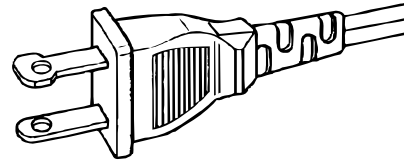

AC POLARIZED PLUG

13. Power-Cord Protection – Power-supply cords should be routed so that they are not likely to be walked on or pinched by items placed upon or against them, paying particular attention to cords at plugs, convenience receptacles, and the point where they exit from the product.
14. Protective Attachment Plug – The product is equipped with an attachment plug having overload protection. This is a safety feature. See the Instruction Manual for replacement or resetting of the protective device. If replacement of the plug is required, be sure the service technician has used a replacement plug specified by the manufacturer that has the same overload protection as the original plug.
15. Outdoor Antenna Grounding – If an outside antenna or cable system is connected to the product, be sure the antenna or cable system is grounded so as to provide some protection against voltage surges and built-up static charges. Article 810 of the National Electrical Code, ANSI/NFPA 70, provides information with regard to proper grounding of the mast and supporting structure, grounding of the lead-in wire to an antenna discharge unit, size of grounding conductors, location of antenna-discharge unit, connection to grounding electrodes, and requirements for the grounding electrode. See Figure 1.
16. Lightning – For added protection for this product during a lightning storm, or when it is left unattended and unused for long periods of time, unplug it from the wall outlet and disconnect the antenna or cable system. This will prevent damage to the product due to lightning and power-line surges.
17. Power Lines – An outside antenna system should not be located in the vicinity of overhead power lines or other electric light or power circuits, or where it can fall into such power lines or circuits. When installing an outside antenna system, extreme care should be taken to keep from touching such power lines or circuits as contact with them might be fatal.
18. Overloading – Do not overload wall outlets, extension cords, or integral convenience receptacles as this can result in a risk of fire or electric shock.
19. Object and Liquid Entry – Never push objects of any kind into this product through openings as they may touch dangerous voltage points or short-out parts that could result in a fire or electric shock. Never spill liquid of any kind on the product.
20. Servicing – Do not attempt to service this product yourself as opening or removing covers may expose you to dangerous voltage or other hazards. Refer all servicing to qualified service personnel.
21. Damage Requiring Service – Unplug this product from the wall outlet and refer servicing to qualified service personnel under the following conditions:
  - a. When the power-supply cord or plug is damaged.
  - b. If liquid has been spilled, or objects have fallen into the product.
  - c. If the product has been exposed to rain or water.
  - d. If the product does not operate normally by following the operating instructions. Adjust only those controls that are covered by the operating instructions as an improper adjustment of other controls may result in damage and will often require extensive work by a qualified technician to restore the product to its normal operation.

# Table of Contents

<b>1. Instruction for use</b> .....	<b>2</b>
Foreword .....	2
Equipment mains setting .....	2
Copyright .....	2
Precautions .....	2
<b>2. Accessories</b> .....	<b>2</b>
<b>3. Main features of this product</b> .....	<b>3</b>
<b>4. Connections</b> .....	<b>4</b>
<b>Connection 1 Stereo Bi-wiring Connection</b> .....	<b>4</b>
Bi-Wiring .....	5
Wiring the speaker system .....	5
Wiring speaker cable .....	5
<b>Connection 2 Stereo Bi-Amp Connection</b> .....	<b>6</b>
Bi-Amp (wiring) .....	7
Wiring the speaker system .....	7
<b>Connection 3 Stereo complete Bi-Amp Connection</b> .....	<b>8</b>
Complete Bi-Amp Connection .....	9
Balanced terminal .....	9
<b>Installing the SACD multi-channel audio speakers</b> .....	<b>10</b>
<b>Connection 4 5.1ch multi channel Connection</b> .....	<b>11</b>
Wiring speaker system .....	11
<b>5. Name and function</b> .....	<b>12</b>
<b>6. Specification</b> .....	<b>13</b>
<b>7. Block diagram</b> .....	<b>13</b>
<b>8. Trouble shooting</b> .....	<b>14</b>
About the Protective Circuit .....	14
<b>9. Maintenance</b> .....	<b>14</b>

# 1. Instruction for use

## ■ Foreword

This section must be read before any connection is made to the mains supply.

## ■ Equipment main AC power setting

Your Marantz product has been prepared to comply with the household power and safety requirements that exist in your area.

MA 9S1/N1G can be powered by 230 V AC only.

MA 9S1/U1G can be powered by 120 V AC only.

## ■ Copyright

Recording and playback of any material may require consent. For further information refer to the following:

- Copyright Act 1956
- Dramatic and Musical Performers Act 1958
- Performers Protection Acts 1963 and 1972
- any subsequent statutory enactments and orders

## ■ Precautions

The following precautions should be taken when operating the equipment.

### ● General Precautions

When installing the equipment ensure that:

- the ventilation holes are not covered;
- air is allowed to circulate freely around the equipment
- it is on a vibration free-surface;
- it will not be exposed to interference from an external source;
- it will not be exposed to excessive heat, cold, moisture or dust;
- it will not be exposed to direct sunlight;
- it will not be exposed to electrostatic discharges

Never place heavy objects on the equipment.

If a foreign body or water does enter the equipment, contact your nearest dealer or service center.

Do not pull out the plug by pulling on the mains lead, pull from the plug itself. It is advisable when leaving the house, or during a thunderstorm, to disconnect the equipment from the mains supply.

# 2. Accessories

After opening the cover of the packing box, check that the following accessories are included.

- AC Power Cable

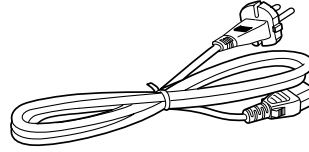

(MA 9S1/N1G)

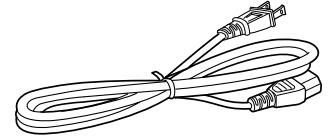

(MA 9S1/U1G)

- Instruction Manual (this Copy)

# 3. Main features of this product

---

## ● The concept : Instantaneous current delivery capability

Even if amplifiers have the same power specifications, their performance may not be the same due to a difference in current delivery capability.

The delivery capability of power amplifiers depends on how instantaneous the current supply is.

That's why the power supply for the MA-9S1 was completely revamped to give it a truly instantaneous current supply capability that has been increased three times as much compared to any Marantz product designed before.

## ● Fully balanced monaural power amp

To minimize the influence of strong "return current" occurring from the loudspeaker system, the circuit for the power amp consists of two amplifiers giving a voltage gain amp of 23dB, in a push-pull balanced construction, for the final buffer amp of 6dB.

## ● HDAM SA

The feedback impedance of the Current Feedback circuit was reduced to its minimum to make it faster.

We developed a new High Definition Amplifier Module (HDAM), a separated module operating as a buffer for the amplifier.

## ● Choke input system

The power supply of the voltage gain amplifier's adopted choke input system has few ripples and is durable with load changes.

This can prevent noise from the amplifier as well as reduce noise from the primary winding, resulting in a clean power supply.

## ● Ultra low impedance amplifier

The buffer amplifier's power supply block, which supports the high current delivery capability, uses a capacitance input system to realize very low impedance.

The Super Ring Power transformer, the low impedance electrolytic capacitors, the very large gauge internal wiring, and the thick pattern PCB all contribute in supplying the required power.

# 4. Connections

## Connection 1 Stereo Bi-wiring Connection

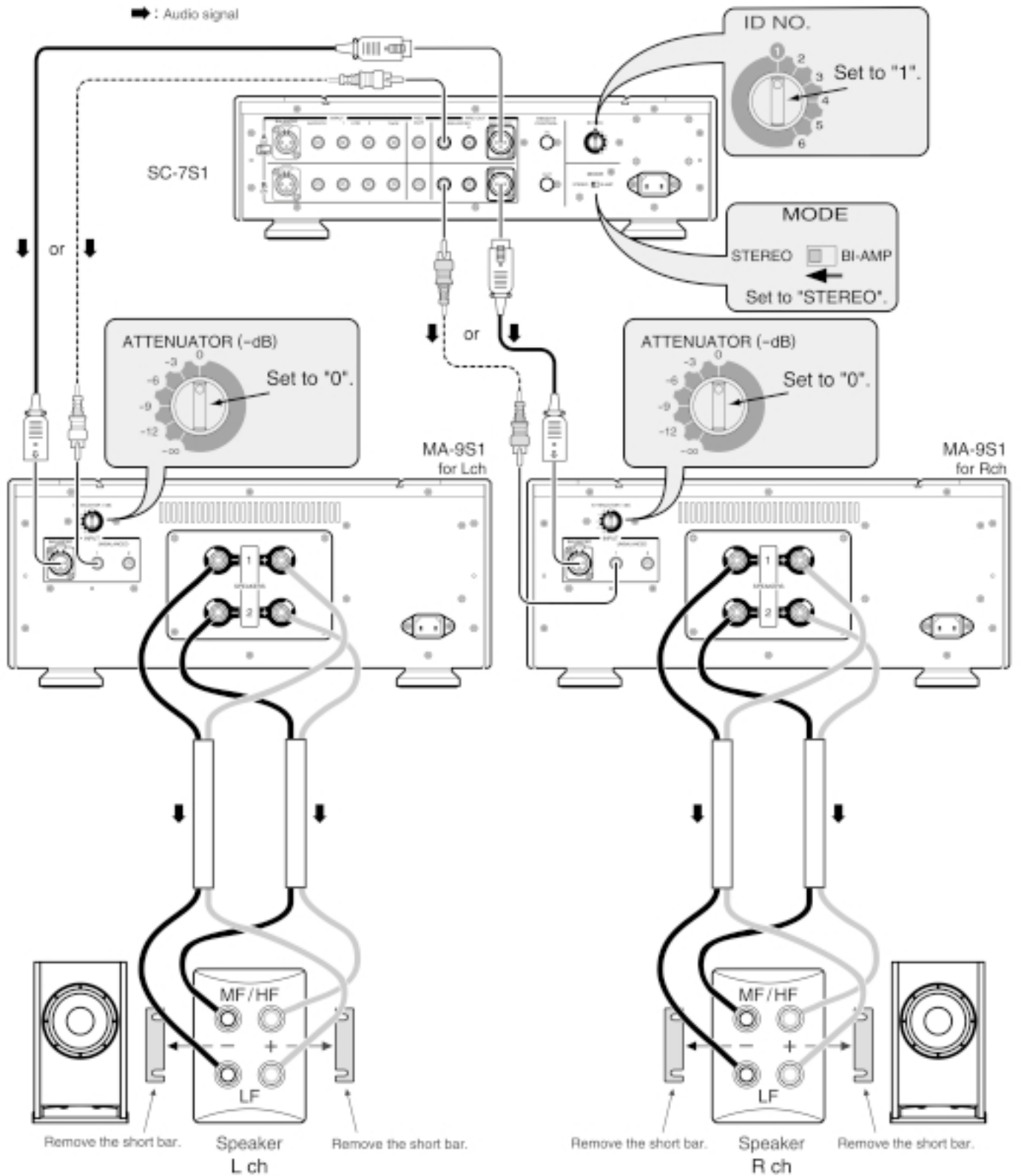

This connection can have options i.e. You may connect the units using either balanced or unbalanced cables.

**Connection 1 - 4 are recommended by Marantz for the SC-7S1 with Marantz MA-9S1s.**  
**All Connections are based on speaker systems that are capable of Bi-Wiring.**  
**Please read the instruction manual for the SC-7S1 for use. Name and Function → P12**

### ■ Bi-Wiring

The method is to improve sound quality, by connecting speaker cable respectively to each terminal for Bass and Mid/High speakers. This method will reduce interference caused by the bass speaker and the Mid/High speaker unit being powered by the same amplifier.

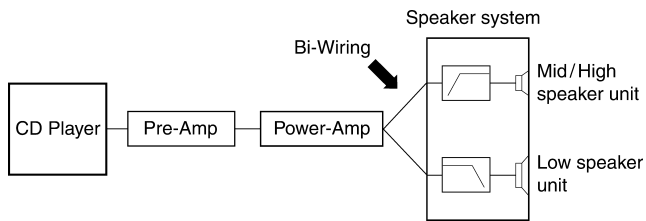

### ■ Wiring the speaker system

#### ● Speaker system doesn't comply with the Bi-Wiring

Please connect either of the speaker terminals 1 or 2. And please use a speaker system whose impedance is for 4 - 16Ω. If impedance is lower than 4Ω, the protection circuit will be engaged during play. This will result in no output of the Amplifier.

#### ● Speaker system complies with the Bi-Wiring

Please connect both of the speaker terminals 1 and 2. And please use a speaker system whose impedance is for 4 - 16Ω. If impedance is lower than 4Ω, protection circuit will be engaged during play. This will result in no output of the Amplifier.

#### ● Polarity of Speaker output terminal

Speaker terminals have positive (+ : Red) and negative (- : White) polarity and speaker wires also have (+ & -) polarity. In wiring, be sure to connect the terminals with the same polarity (+ and +, - and -).

### ■ Wiring the speaker

#### CAUTION:

When connecting two pairs of speaker systems simultaneously, the impedance of each speaker system should be no less than 8 ohm .

Connecting a speaker system with a lower impedance than 8 ohm may activate the protection circuitry and make normal stereo reproduction impossible.

- Be careful not to short circuit or touch the speaker cables to each other.
- Peel off the coating or insulation of the speaker cable as shown below.

- Wiring with speaker cable.

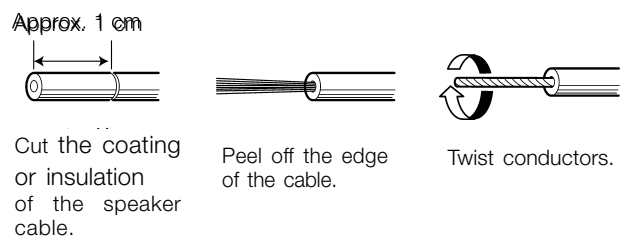

- Wiring with "Y" style terminal

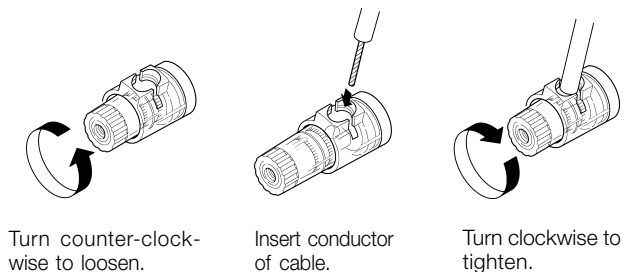

### Connection 2 Stereo Bi-Amp connection.

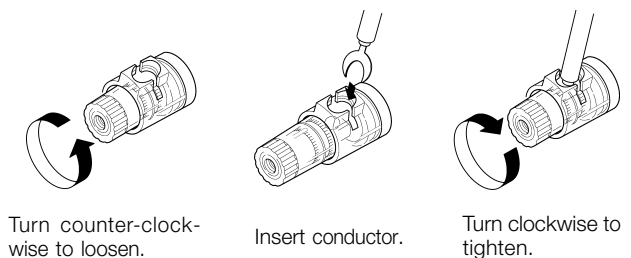



# 4. Connections

## Connection 2 Stereo Bi-Amp connection.

(Make sure your speakers are designed for Bi Amp capabilities)

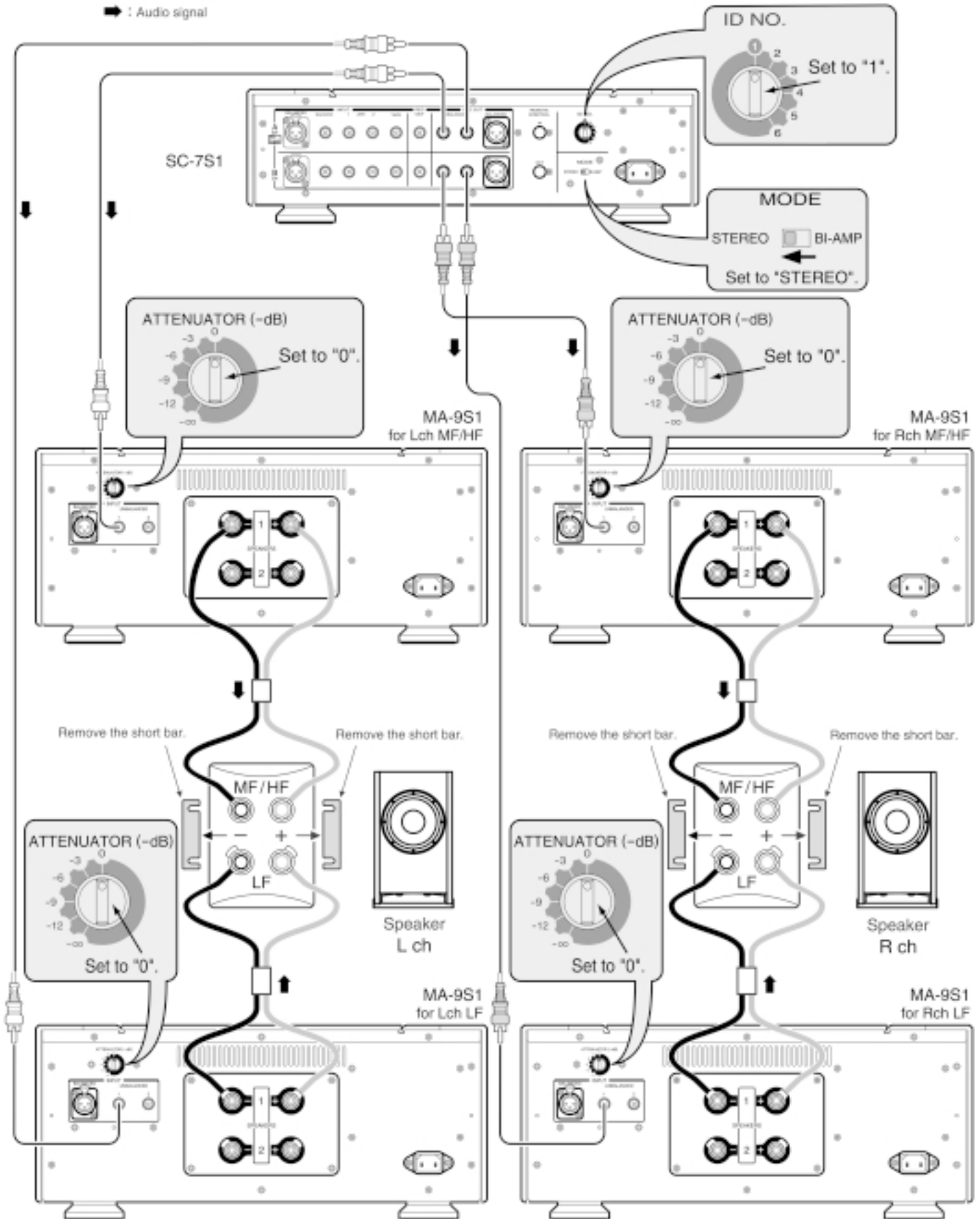

Enhance connection 1 to Bi-Amp connection, and drive the bass speaker and Mid / High Frequency speakers with separate power Amplifiers.

### ■ Bi-Amp (connection)

The benefits of Bi-Wiring; drive the bass speaker and Mid / High speakers with separate power Amplifiers. Bi-Amping will lessen the burden of Power Amp impedance, so that back electromotive force between the Low and Mid/High signal can be lessened. We can expect drastic improvement of sound quality.

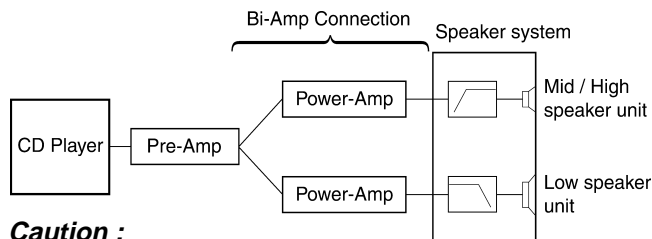

#### **Caution :**

In the event of this connection (Control Amp SC-7S1 is <Stereo>mode), SC-7S1 and MA-9S1 can be wired by Unbalanced only.

### ■ Wiring the speaker system

- Please remove short bar of the speaker terminal.  
If the short bar, has not been removed, it will damage the power amplifier.
- Please use speaker systems whose impedance are for 4 - 16Ω.  
If impedance is lower than 4Ω, the protection circuit will be engaged during play.
- Make sure your speakers are designed for Bi Amp capabilities. If they don't the protection circuit will be engaged and there will be no output. Or it will damage the power amplifier.

# 4. Connections

**Connection 3 Stereo complete Bi-Amp connection.**  
 (Make sure your speakers are designed for Bi Amp capabilities)

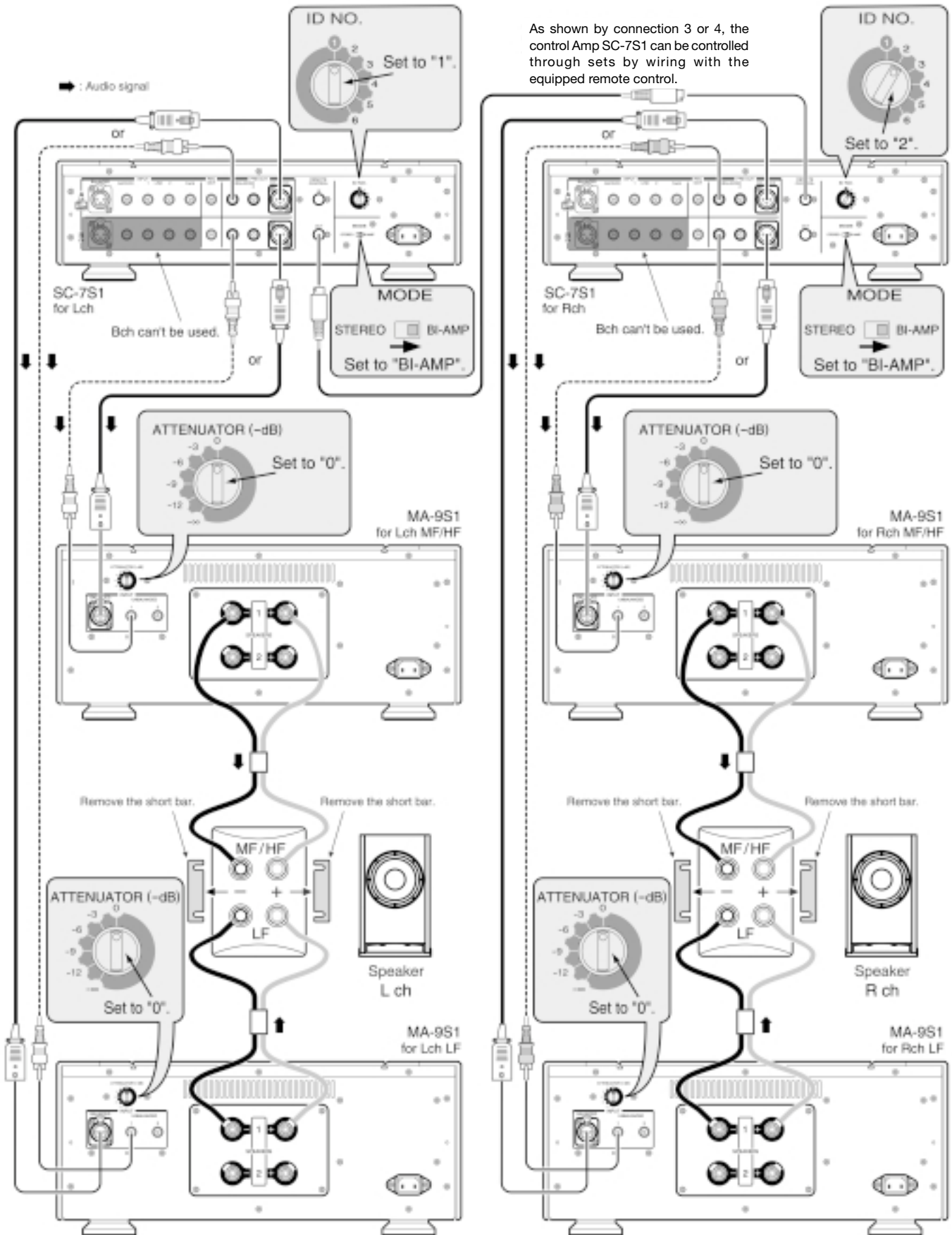

**This connection can have options i.e. You may connect the units using either balanced or unbalanced cables. But, you have to use the same cables per SC 7S1.**

### ■ Complete Bi-Amp Connection

Enhance connection 2, by having one more control Amp. SC-7S1. This is a Complete Bi-Amp connection which separates Mid / High signal and Low signal from the Pre-Amp section.

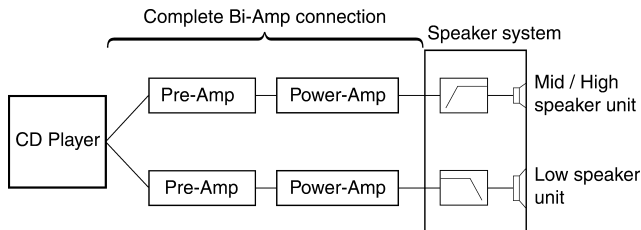

In this event, the SC-7S1 is using Monaural Amps. And separate Left/Right channels from the output terminal of CD players. As a result, influences between L channel and R channel Mid / High signal and Low signal will be eliminated.

A maximum of 6 SC-7S1s, can be connected to each other, via remote cables.

#### **Caution**

In the event of setting the mode switch as <Bi-Amp>, B channel input terminals can't be used.

### ■ Balanced terminal

- ① The balanced output connector uses a XLR connector.
- ② The XLR connector is internally wired in either of the following two systems.

1. USA system (Pin 2 = COLD, Pin 3 = HOT)

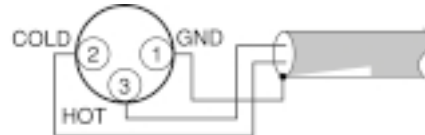

2. European system (Pin 2 = HOT, Pin 3 = COLD)

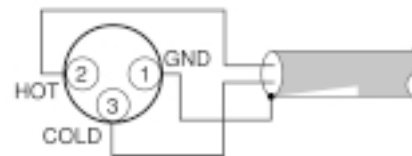

- ③ The MA-9S1 uses the USA system of 1.

When a preamp or main amplifier adopting the European system is connected using a cable with XLR balanced connectors, the reproduced signal may be inverted of phase.

In this case, correct the wiring of the one of the XLR connectors on the extremities of the cable to the USA system by exchanging the connections of pins 2 and 3. This will make it possible to play the signal with the correct phase.

## 4. Connections

### ■ Installing the SACD multi-channel audio speakers

In order to enjoy SACD multi-channel sound with the best possible acoustics, it is recommended that the speaker systems be laid out in compliance with the ITU-R BS.775-1 recommendation which is a standard formulated by the International Telecommunication Union (ITU).

SACD multi-channel discs are recorded and mixed in such a way that they will achieve the optimum effects when the speaker systems are laid out as per the ITU-R BS.775-1 recommendation.

- On SACD multi-channel discs, the music signals are basically recorded using 5 channels (or 3, 4 or 6 channels in some cases). In some instances, however, LFE (for the sub woofer) is recorded as a sixth channel.

Each disc indicates how many channels have been recorded on it.

- The basic settings are 3 speakers for front and 2 for back since multi-channel discs have basically 5 channels

The 2-front, 1-center, and 2-surround speakers should be set on the circle from the listening point as shown below.

When you use different sizes of speakers, please adjust the volume balances.

- The location of the sub-woofer in the picture is just an example. The Sub-woofer can be located any place in your room. (See the users manual of your sub-woofer.)

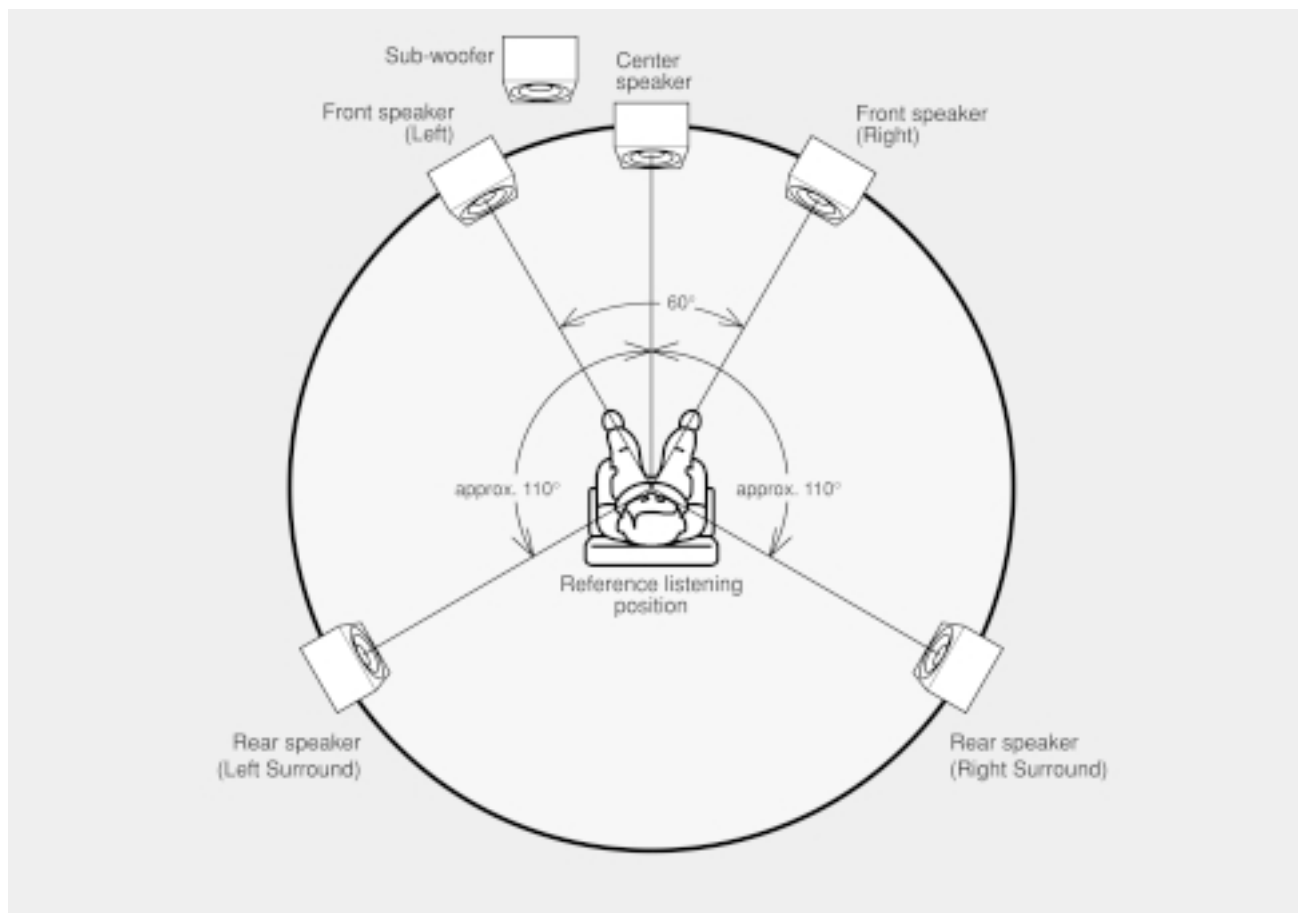

## 4. Connections

### Connection 4 5.1ch multi-channel connection

Below is the standard connection for a Multi-channel sound source. This will enable you to experience the high quality sound acoustic for the professional Home theatre and pure multi channel SACD. The complete 5.1 system is controlled using 3 SC-7S1 Stereo Control Amplifiers.

The system can be enhanced to

- <3 SC-7S1s + 10 MA-9S1s + Active sub-woofer>
- <6 SC-7S1s + 10 MA-9S1s + Active sub-woofer>

This connection can have options i.e. You may connect the units using either balanced or unbalanced cables. But, you have to use the same cables per SC 7S1.

### ■ Wiring speaker system

Please refer to <Wiring speaker system> p.5 of connection 1.

#### Caution

- If you use an Active (powered) sub-woofer for LFE, please refer to the Users manual of the Active sub-woofer for set up instructions. LFE (Low Frequency Effect) is the channel for Low Frequency only.
- If you use a Passive sub-woofer for LFE, a Monaural power Amp such as the MA-9S1 can be used to drive it.

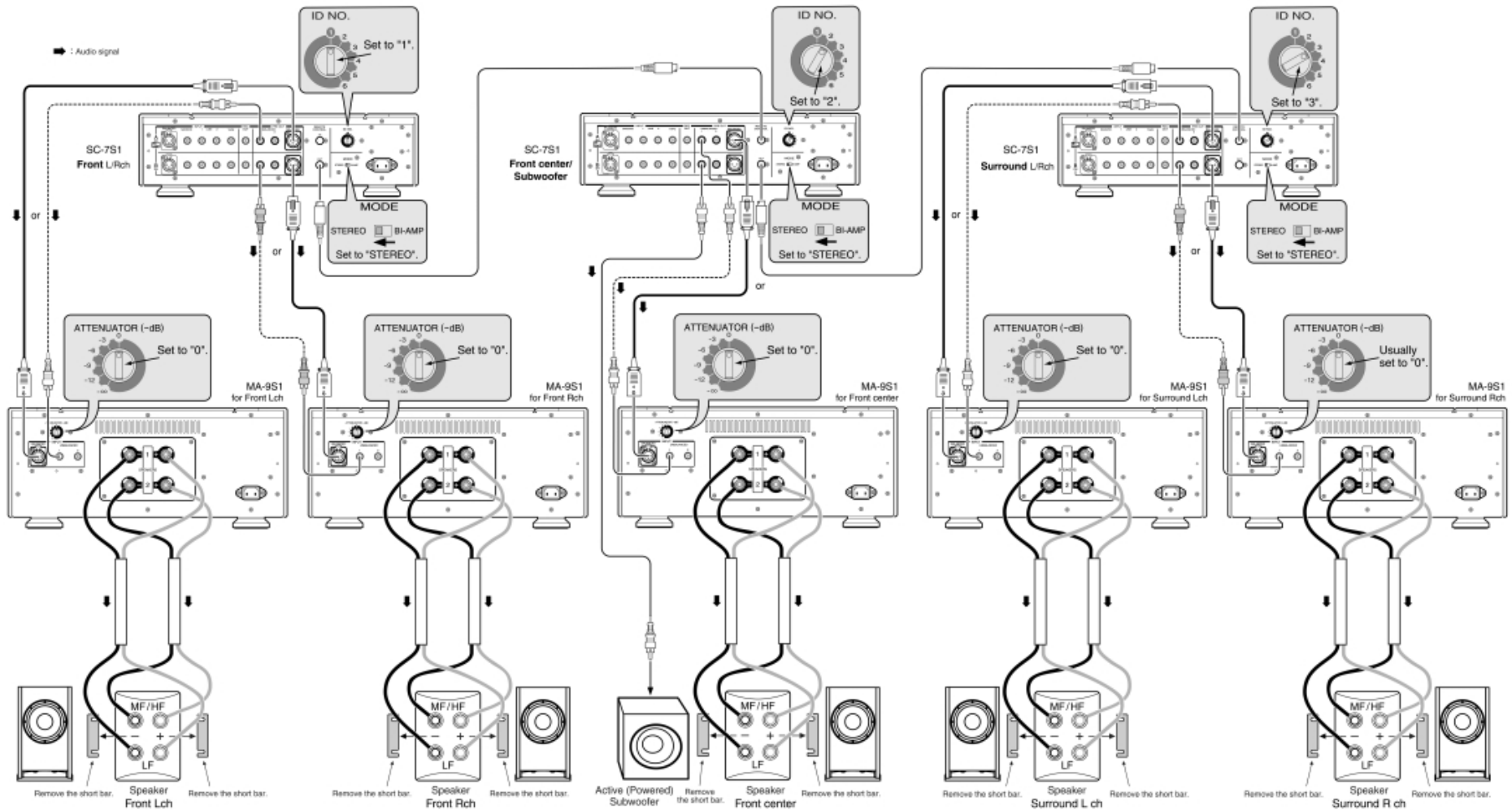

## 5. Name and function

### Front panel

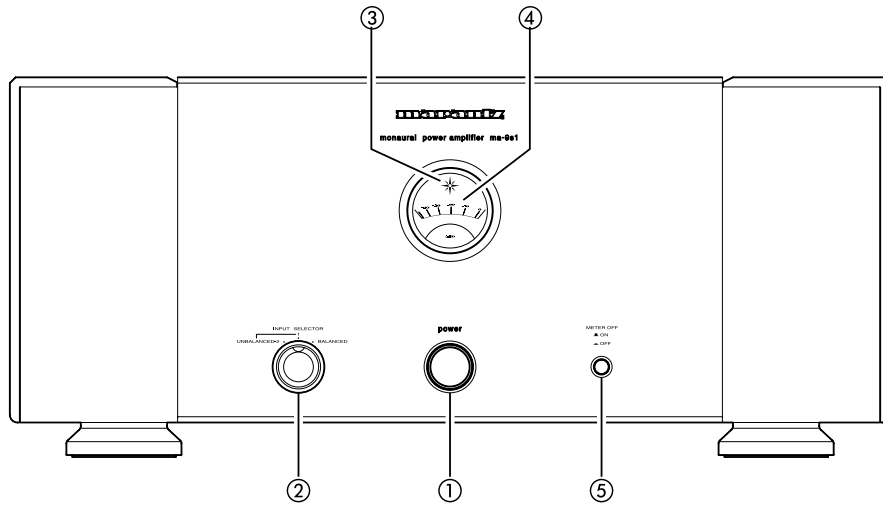

#### ① Power switch

Press the power switch to turn the power on/off. When the power is on, the power indicator 3 will be illuminated.

#### ② Input selector

This knob is to select the input source from the Pre-Amp.

#### ③ Power indicator

The power indicator is illuminated while the power switch is on.

#### ④ Level meter

This meter is used to check the output power.

#### Meter indication vs Output power

Indicated level (dB)	8ΩLoad(W)	4ΩLoad(W)
0	300	600
-10	30	60
-20	3	6
-30	0.3	0.6
-40	0.03	0.06

#### ⑤ Meter off switch

This switch is used to turn on/off the level meter and the internal light of the level meter.

### Rear panel

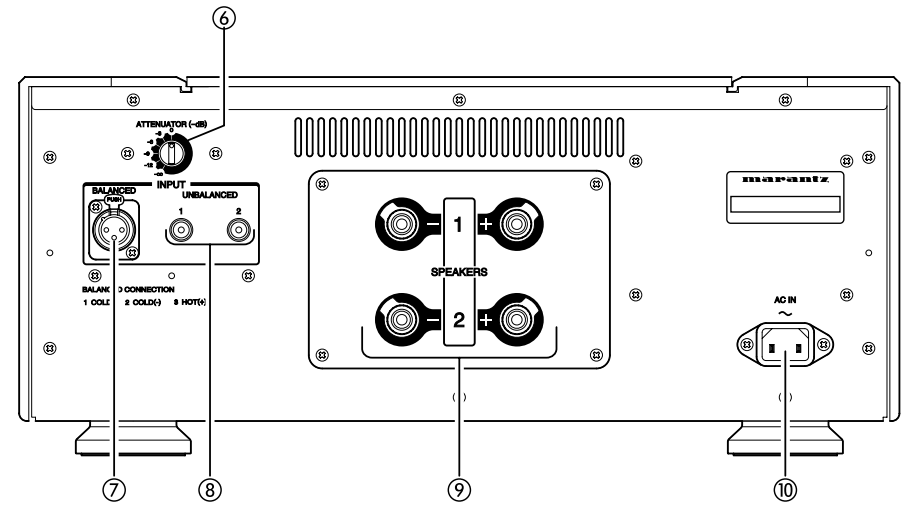

#### ⑥ ATT (Attenuator)

The knob is to attenuate the input level. Initial set up is 0dB.

#### ⑦ Balanced input terminal

Connect to the Balanced output terminal of the Pre-Amp.

#### ⑧ Unbalanced input terminal 1, 2

Connect to the Unbalanced output terminal of the Pre-Amp.

#### ⑨ Speaker output terminal

Connect your speaker system to these terminals. Speaker cable wiring → p.5

#### ⑩ AC IN socket

Connect to a household power outlet.

# 6. Specification

## ■ Specification

Power Output (20Hz - 20kHz) .....	300W (8Ω Load)
	600W (4Ω Load)
T.H.D. (20Hz - 20kHz, 8Ω Load) .....	0.01%
Frequency response (1W, 8Ω Load) .....	3 Hz - 120 kHz
	(+0, -3dB)
Damping factor .....	200
(20Hz - 20kHz, 8Ω Load)	
Input sensitivity/ Input impedance .....	1.7V / 20kΩ (Balanced)
	1.7V / 20kΩ (Unbalanced)
S/N (IHF-A) .....	120 dB (Balanced)
	120 dB (Unbalanced)
Attenuation .....	0, -3, -6, -9, -12, -∞ dB
Power requirement (MA 9 S1/N1G) .....	AC 230V 50Hz
(MA 9S1/U1G) .....	AC 120V 60Hz
Power Consumption (MA 9S1/N1G) .....	500 W (3.2 A)
(MA 9S1/U1G) .....	500 W (5.8 A)
	1200 W (Output: 4Ω, 600W)
Dimensions .....	Width 459 mm
	Height 198 mm
	Depth 451 mm
Weight .....	35.8 kg

\* All specifications, dimensions and weights are subject to change without notice.

## ■ Dimensions Unit : mm

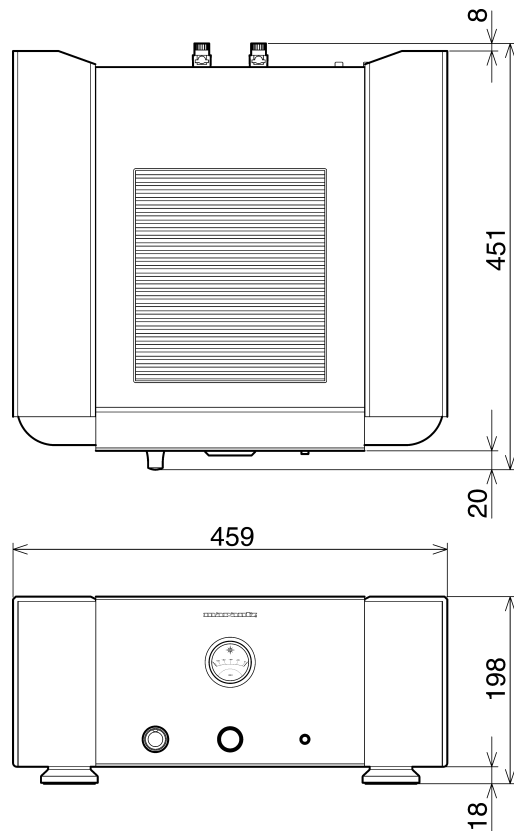

# 7. Block diagram

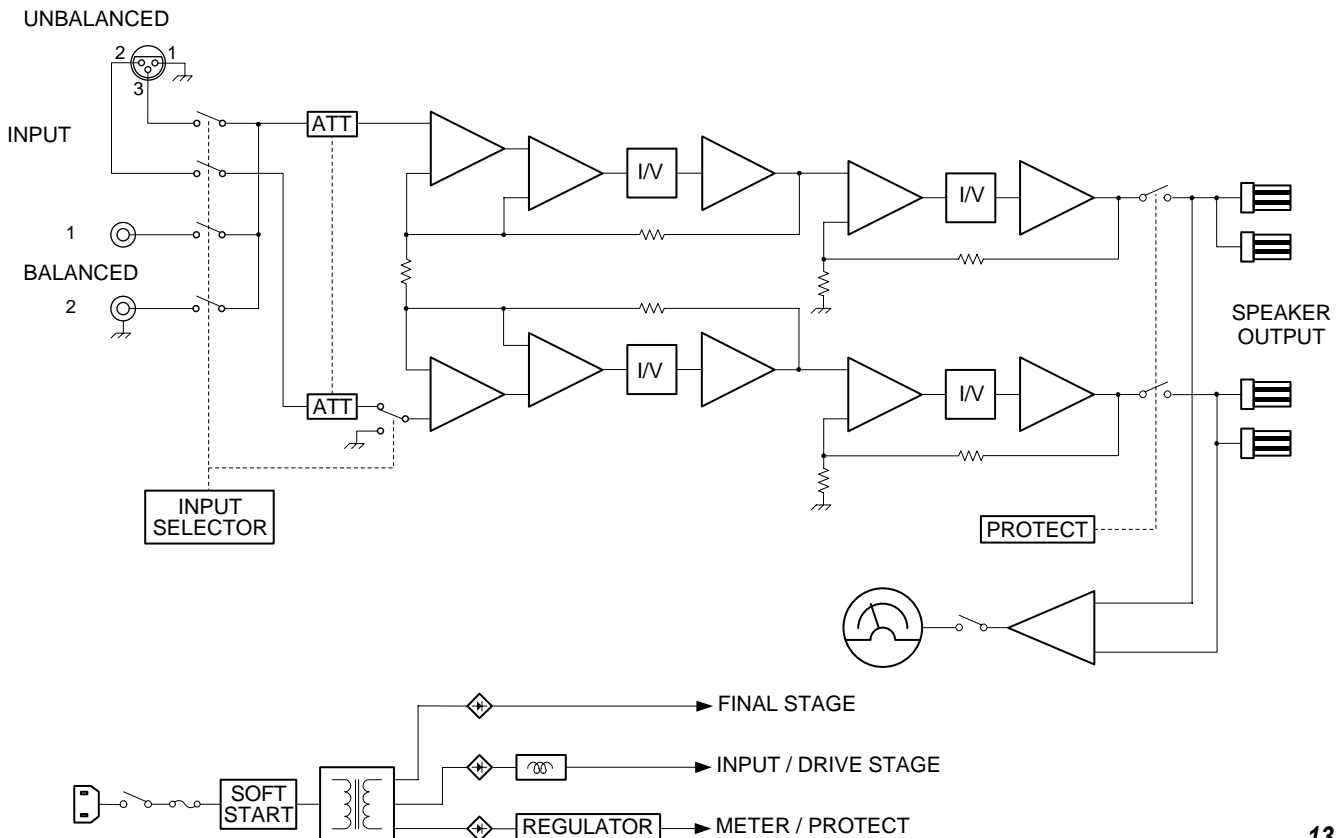



## 8. Trouble shooting

Should faults occur, in many cases it is not necessary to consult your dealer or a Marantz technical service department. On the basis of the following checks you will be able to rectify a number of faults yourself without difficulty.

If the fault cannot be remedied after the following checks, please consult your dealer or nearest Marantz service agent.

### The unit does not turn ON

1. Is the power cable securely plugged into an AC outlet?

### Sound is not coming from the speakers

1. Has the wrong input source been selected with the INPUT SELECTOR on the front panel?
2. Is the ATTENUATOR switch set to  $-\infty$  on the rear panel?
3. Are speaker cables properly connected to the speaker system?
4. Is the connection cable properly connected to the control (pre) amplifier?
5. Is the control (pre) amplifier or input source wrongly set?
6. Are you using the player in the wrong way?
7. The protective circuit of this unit may have worked. Shut power OFF, wait 1 minute or more, then reactivate the power.

## ■ About the Protective Circuit

This unit incorporates a protective circuit that protects the amplifier circuit and speaker system against damage. If the protective circuit works, the meter lights shut off and the sound is muted. (Pressing the METER OFF switch also shuts off the meter lights.) This protective circuit works in the following cases.

### ● At power ON

When power is activated, the protective circuit works and mutes the sound for about 8 seconds until the amplifier circuit stabilizes. Once the amplifier circuit stabilizes, the protective circuit releases and muting is canceled. At the same time, the meter lights turn ON.

### ● If overcurrent flows to the amplifier circuit (Overcurrent protection)

If overcurrent flows to the amplifier circuit because of excessive signal input or if the unit is used with speakers of less than  $4 \Omega$  impedance connected to it, overcurrent is detected and the protective circuit will engage. The protective circuit also will engage if the speaker cables are accidentally shorted. If the protective circuit engages, the meter lights shut off, therefore you will know whether or not that is the problem by checking the meter lights.

If it has engaged, shut the power OFF, wait 1 minute or more, then reactivate the power.

### ● If the amplifier overheats

In the following cases, the amplifier will overheat and the protective circuit will engage.

- If the unit is used with the ventilation blocked or obstructed
- If speakers of less than  $4 \Omega$  impedance are used
- If the unit is used for an extended period of time under excessive signal input.

## 9. Maintenance

The section describes the care and maintenance tasks that must be performed to optimize the operation of your Marantz equipment.

### ● Cleaning of equipment external surfaces

The exterior finish of your unit will last indefinitely with proper care and cleaning. Never use scouring pads, steel wool, scouring powders or harsh chemical agents (e.g., lye solution), alcohol, thinner, benzene, insecticide or other volatile substances as these will mar the finish of the equipment. Likewise, never use cloths containing chemical substances. If the equipment gets dirty, wipe the external surfaces with a soft, lint-free cloth.

If the equipment becomes heavily soiled:

- dilute some washing liquid in water, in a ratio of one part detergent to six parts water.
- dip a soft, lint free cloth in the solution and wring until it is damp.
- wipe the equipment with the damp cloth.
- dry the equipment by wiping it with a dry cloth.



### ● Repairs

Only the most competent and qualified service technicians should be allowed to service your unit. The factory-trained warranty station personnel have the knowledge and special facilities needed for repair and calibrate this precision equipment. After the warranty period has expired, repairs will be performed for a charge.

In the event of difficulty, refer to your dealer or write directly to the nearest location to you that is listed on the Marantz Authorized Service Station list. If writing, please include the model and serial number of the equipment together with a full description of what you think is abnormal about the equipment's behavior.

## **WARRANTY**

For warranty information, contact your local Marantz distributor.

## **RETAIN YOUR PURCHASE RECEIPT**

Your purchase receipt is your permanent record of a valuable purchase. It should be kept in a safe place to be referred to as necessary for insurance purposes or when corresponding with Marantz.

## **IMPORTANT**

When seeking warranty service, it is the responsibility of the consumer to establish proof and date of purchase. Your purchase receipt or invoice is adequate for such proof.

## **FOR U.K. ONLY**

This undertaking is in addition to a consumer's statutory rights and does not affect those rights in any way.

# **CE MARKING**



The MA9S1/N1G is in conformity with the EMC directive and low-voltage directive.

## **WARNINGS**

- Do not touch the top of the enclosure during operation.
- Do not expose the equipment to rain or moisture.
- Do not remove the cover from the equipment.
- Do not insert anything into the equipment through the ventilation holes.
- Do not handle the mains lead with wet hands.
- Do not cover the ventilation with any items such as tablecloths, newspapers, curtains, etc.
- No naked flame sources, such as lighted candles, should be placed on the equipment.
- When disposing of used batteries, please comply with governmental regulations or environmental public instruction's rules that apply in your country or area.
- Do not place anything about 1 meter above the top panel.
- Make a space of about 0.2 meter around the unit.

**[www.marantz.com](http://www.marantz.com)**

You can find your nearest authorized distributor or dealer on our website.

---

**U.S.A.**      Marantz America, Inc.      1100 Maplewood Drive, Itasca, IL 60143, U.S.A.

---

**marantz**<sup>®</sup> is a registered trademark.



**For U.S.A.**

# marantz®

## Limited Warranty

**Marantz America, Inc. ("Marantz") warrants the following Marantz Products for the periods indicated:**

1. The following Marantz Audio/Video components, have a 3 year warranty for both Parts & Labor, from the original purchase date:

**Amplifiers, Pre Amplifiers, Pre Amplifier-Processor-Tuners, Integrated Amplifiers, Tuners, Receivers, DVD Players, CD-Recorders, CD Players, Audio Cassette Decks, Learning Remote Control Devices & DLP front Projectors.**

2. **VCR's, Wallvisions, Plasma TVs, LCD TVs & HDD Products** have a 1 year warranty for parts and labor from the original purchase date.
3. **Rear Projection TVs** have a 2 year warranty for parts and labor from the original purchase date.
4. **DLP lamps** have a 90 day warranty for parts and labor from the original purchase date.

### **What is covered and what is not covered**

Except as specified below, this warranty covers parts and labor to correct all defects in materials and workmanship. The following are not covered by the warranty:

1. Damage, deterioration, malfunction or failure to meet performance specifications resulting from:
  - a) Accident, acts of nature, misuse, abuse, neglect or unauthorized product modification.
  - b) Improper installation, removal or maintenance, or failure to follow instructions supplied with the product.
  - c) Repair or attempted repair by anyone not authorized by Marantz to repair the product.
  - d) Any shipment of the product (claims must be presented to the carrier).
  - e) Any cause other than a product defect.
2. Cleaning, initial set-up, check-ups with no defects found, or charges incurred for installation, removal or reinstallation of the product.
3. Any product on which the serial number has been defaced, modified or removed.
4. Batteries.
5. Accessories, including but not limited to, batteries, cables, mounting hardware and brackets, cleaning accessories, antenna and detachable power cords.
6. Warranty is void if purchase was made from any one other than an authorized Marantz dealer.

## **Marantz America, Inc.**

1100 Maplewood Drive,  
Itasca, IL 60143  
Phone. 630-741-0300 Fax. 630-741-0301

### **Who may enforce the warranty**

This warranty may be enforced only by the original purchaser.

### **What we will pay for**

We will pay for all labor and material expenses for items covered by the warranty. Payment of shipping charges is discussed in the next section of this warranty.

### **How you can get service**

1. If your unit needs service, contact Marantz service referral by calling toll-free **1-800-270-4533**. We will advise you of the name and location of one or more authorized Marantz service stations from which service can be obtained. Please do not return your unit to the factory without prior authorization.
2. You must pay any shipping charged if it is necessary to ship the product for service. However, if the necessary repairs are covered under warranty, we will pay the return shipping charges to any destination within the United States, its possessions or territories.
3. Whenever warranty service is required, you must present the original dated sales receipt or other proof of date of purchase.

### **Limitation of implied warranties**

All implied warranties, including warranties of merchantability and fitness for a particular purchase, are limited in duration to the length of this warranty.

### **Exclusion of damages**

Marantz liability for any defective product is limited to repair or replacement of the product at Marantz's option. Marantz shall not be liable for damage to other products caused by any defects in Marantz products, damages based upon inconvenience or loss of use of the product, or any other damages, whether incidental, consequential, or otherwise.

### **How state law relates to the warranty**

Some states do not allow limitations on how long an implied warranty lasts and/or do not allow the exclusion or limitation of incidental or consequential damages, so the above limitations or exclusions may not apply to you.

This warranty gives you specific legal rights, and you may also have other rights which vary from state to state.