

9.user operation instruction

operation instructions for this system are contained in the motor cycle's user manual,from which the portions related to the system are transcribed below:

-This motor cycle is equipped with an immobilizer system.

-The immobilizer system is designed to disable the engine unless a registered key dedicated to your motor cycle is used,and it can prevent unauthorized use of the vehicle.

-Operation procedure:

each key incorporates an unique identification code. When a key is inserted into the ignition switch and turned to the "ON" position,the engine controller installed on the vehicle receives the code from the inserted key and judges whether the inserted key is a registered one or not. The engine can be activated only when the result of the judgement is "OK".

The driver can see the result of the judgement shown in the indicator in the instrument Panel. In the case that the inserted key is a registered one,the indicator light stays on for 2 seconds,whereas for an unregistered key, after the initial 2 seconds the indicator blinks as long as the ignition switch is in the "ON" position.

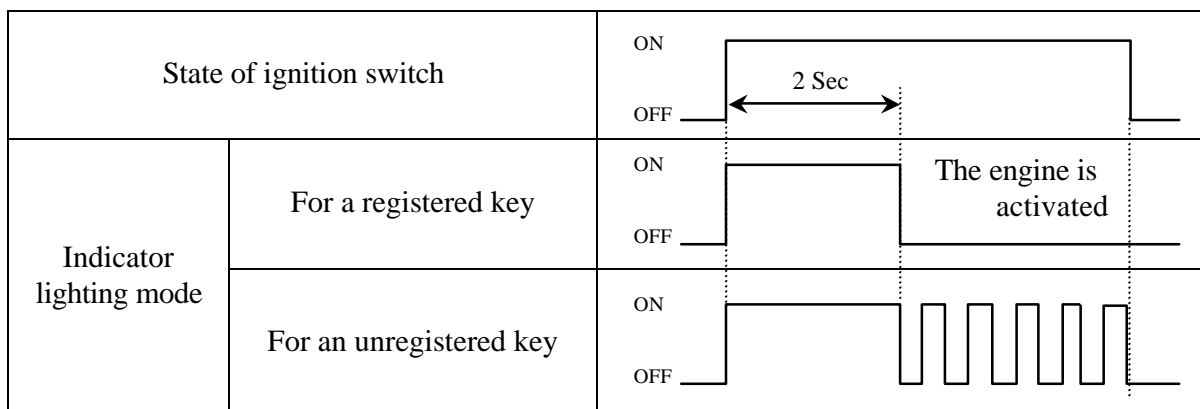

-notice on handling:

The key should not suffer ant strong impact also do not leave it in a high-temperature Environment,since electronic devices are incorporated within the key.

If you lose your key,see your HONDA dealer immediately,and bring with you all of the Remaining keys you have,the key number plate supplied with your key and you vehicle.

Care should be taken not to lose all of keys,as in such a case the ignition unit will Have to be replaced totally.

A duplicated key cannot be used unless the code-registering procedure is performed.

A maximum of four keys can be registered. If you want to have additional keys other than those you have been supplied with, follow the same procedure as required when you lose a key.

Never make a change nor a modification on the immobilizer system, as it may result in disabling the engine.

Changes or modifications not expressly approved of by the manufacturer for compliance could void the user's authority to operate the device.

FCC WARNING

Changes or modifications not expressly approved by the party responsible for compliance could void the user's authority to operate the equipment.

NOTICE

This device complies with Part 15 of the FCC Rules. Operation is subject to the following two conditions:

- (1) this device may not cause harmful interference, and
- (2) this device must accept any interference received, including interference that may cause undesired operation.