

UHF BAND DIVERSITY IN-EAR MONITOR SYSTEM

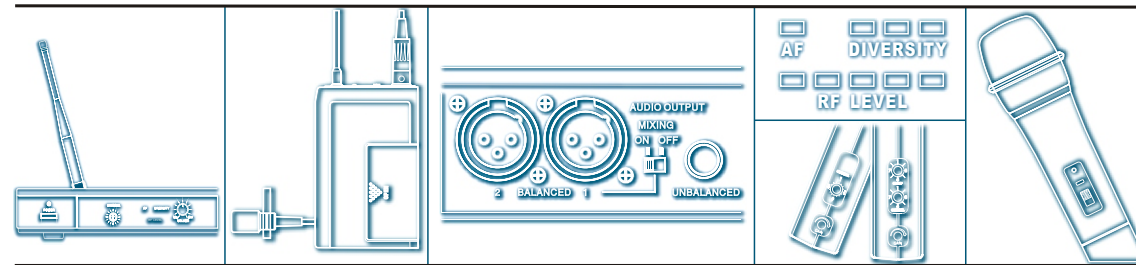

1. Introduction

Thank you for purchasing our product. This in-ear monitor system operates in UHF band frequency with Phase Locked Loop (PLL) synthesizer controlled. The system with 16 or 64 selectable frequencies via PLL circuitry makes it easy to choose non-interfered channels. Please read this instruction manual carefully before operating the system. This manual covers the function and operation of the in-ear monitor system.

2. Safety

- Do not spill liquid on the appliance and do not drop it on a hard surface.
- Do not place the appliance near heat sources, such as radiators, amplifier, etc.. Do not expose it directly to sunlight, extremely dust, excessive moisture, or vibration.
- Unplug the power if the appliance has been not used for a long period. This will avoid the damage resulted by surge electricity.

3. Feature

- IEM-168 is a Low-Power FM broadcasting transmitter. At the same time, it can send out stereo music (work with CD player, MP3, etc.) and vocal broadcasting (works with wired or wireless microphone system).
- There are up to 16 or 64 selectable channels to set up a multi-channels broadcasting system and to avoid the frequency inference. Also, the LED displayer gives us a clear channel indication. And, user can select channels or groups easily by using rotary switch.
- The stereo audio signal (works with CD player, MP3, etc.) can be input easily through the RCA jack.
- The wired microphone can be connected to the 6.3 Φ jack or to the XLR connector.
- The Peak LED indicator can help avoiding the audio distortion.
- User can plug a headphone into the headphone jack on the front panel to monitor the sending out audio signal.
- IEM-168's antenna is a high efficiency antenna. The service area can be improved when the antenna is placed at higher location.
- IEM-168 can combine with a RF power booster (AB-168, which is 1Watt max) to used for an over 1 km area service.

4. Product Description

1. Power: push bottom to power on and push again to power off.
2. Group Rotary: adjust rotary to select frequency group.
3. Channel Rotary: adjust rotary to select frequency channel.
4. Channels LED display: indicate the current channel number. The number would show up when the power is on.
5. MIC Volume Control: adjust the volume of MIC input level.
6. Line Volume Control: adjust the volume of Line In input level.
7. Monitoring Headphone Volume Control: adjust the volume of monitoring headphone.
8. Peak Indicator: indicate the input audio signal is too high and may cause distortion.
9. Headphone Jack: 6.3 Φ headphone jack stereo type.
10. Antenna Socket: TNC socket for antenna.
11. MIC IN: 6.3 Φ / XLR jack for wired microphone.
12. Stereo/Mono Switch: switch the stereo or mono mode of audio signal.
13. Line IN: RCA jack for stereo audio input.
14. DC Power Jack: DC input connector for the supplied AC adapter.

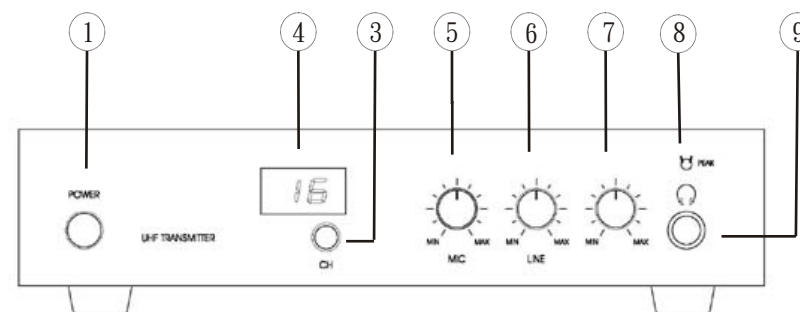

Fig. 1 16 channels model
Front panel

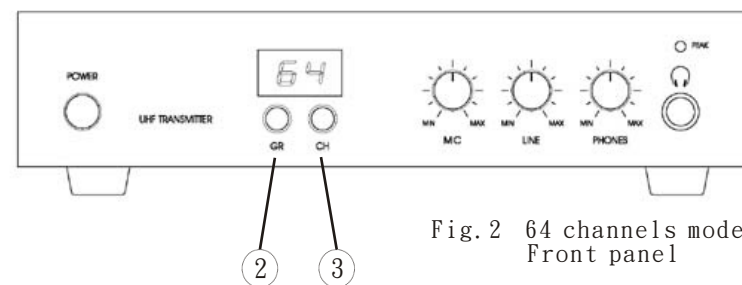

Fig. 2 64 channels model
Front panel

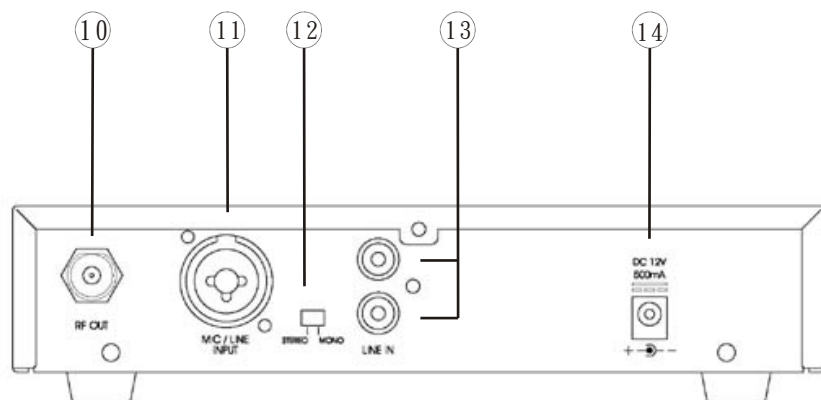

Fig. 3 rear panel

5. Setting-Up

NOTICE: Prior to setting up, please make sure the microphone and the receiver are turned to the same frequency. Two or above wireless microphones operating in the same frequency can not be used at the same time and area. So please select the different frequencies which can be used simultaneously at the same area.

5.1 Connecting the transmitter to power

- Attach the UHF antenna to the TNC connector on the rear panel.
- Please check the voltage of the supplied AC adapter conforms to the voltage available in local area. Using the wrong AC adapter may cause irreparable damage to the unit.
- Plug the feeder cable of the supplied AC adapter into DC IN socket on the transmitter. Then plug the AC adapter into a power outlet.

5.2 Setting up the transmitter

- Connect 6.3 Φ plug or XLR plug of the wired microphone in MIC IN jack on the transmitter rear panel. Turn the MIC Volume Control on the transmitter clockwise to set the transmitter input to receiver level.
- Use the RCA plug to connect the Audio In jack on the transmitter rear panel. Turn the Line Volume control on the transmitter clockwise to set the transmitter input to receiver level.
- For monitoring purpose, plug the headphone into the monitoring headphone jack on the front panel of transmitter. Turn the Monitoring Headphone Volume on the transmitter clockwise to set the headphone volume.

5.3 Setting up the frequency

- For 16 channels model, adjust channel rotary to select channel to set up frequency.
- For 64 channels model, frequency is divided into 8 groups, which there are 8 channels in each group. Adjust group rotary to setup group number. Adjust channel rotary to setup channel number.

THIS DEVICE COMPLIES WITH PART 15 OF THE FCC RULES. OPERATION IS SUBJECT TO THE FOLLOWING TWO CONDITIONS: (1) THIS DEVICE MAY NOT CAUSE HARMFUL INTERFERENCE AND (2) THIS DEVICE MUST ACCEPT ANY INTERFERENCE RECEIVED, INCLUDING INTERFERENCE THAT MAY CAUSE UNDESIRE OPERATION.

Notice : The changes or modifications not expressly approved by the party responsible for compliance could void the user's authority to operate the equipment.

IMPORTANT NOTE: To comply with the FCC RF exposure compliance requirements, no change to the antenna or the device is permitted. Any change to the antenna or the device could result in the device exceeding the RF exposure requirements and void user's authority to operate the device.

TROUBLE-SHOOTING

6. Trouble-shooting

Problem	Solution
No sound	<ul style="list-style-type: none"> ● Check the power supply of the transmitter and receiver. ● Check that the transmitter and receiver are turned to the same frequency. ● Check whether the Hi-Fi appliance is switched on and the transmitter output is connected to mixer or amplifier input. ● Check whether receiver is too far away from transmitter. ● Check whether transmitter is located too near metal object or there are obstructions between transmitter and receiver.
Sound interference	<ul style="list-style-type: none"> ● Check the antenna location. ● When using 2 or above transmitters simultaneously, make sure that the chosen frequencies are not interfered. ● Check whether the interference comes from other wireless microphone, TV, radio and etc..
Distortion	<ul style="list-style-type: none"> ● Check the volume control for transmitter is adjusted too high or too low. ● Check whether the interference comes from other wireless microphone, TV, radio and etc..

SPECIFICATION

7. Environment

When disposing the equipment, remove the screws, separate the case, circuit boards, and cables, and dispose of all components according to local waste disposal rules.

8. System Specification

Frequency range	UHF 630 ~ 806MHz
RF power output	10mW or 100mW
Frequency stability	±0.005%
Maximum deviation	±48KHz with limiting compressor
Spurious emission	>60dB below carrier frequency
T.H.D.	<1% (at 1KHz)
Power supply	DC12 ~18V
Tone key	32.768 KHz
Current consumption	85mA ±10mA(10mW) ; 140mA ±10mA(100mW)
Dimension(mm)WxHxD	211x44x180