

UHF

PLL SYNTHESIZED

USER'S MANUAL

UHF BAND WIRELESS MICROPHONE SYSTEM

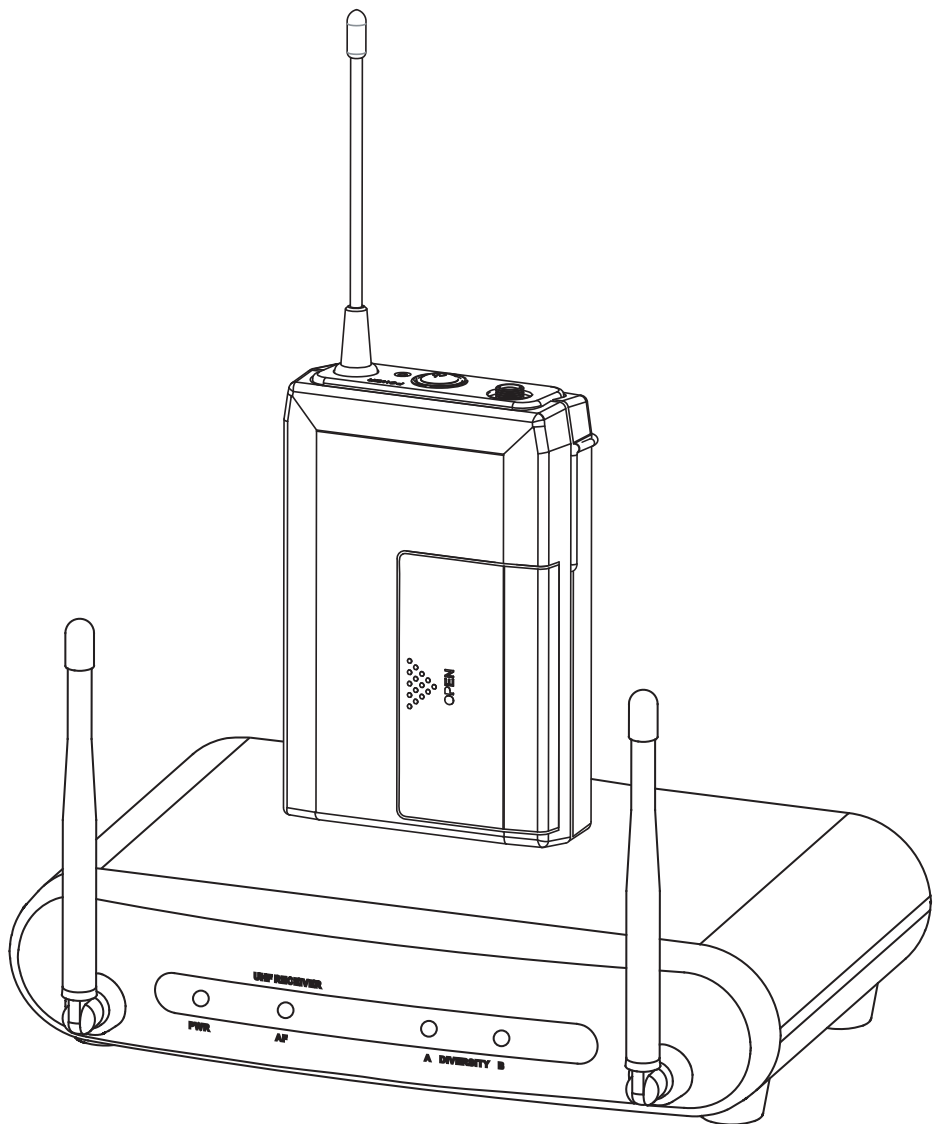
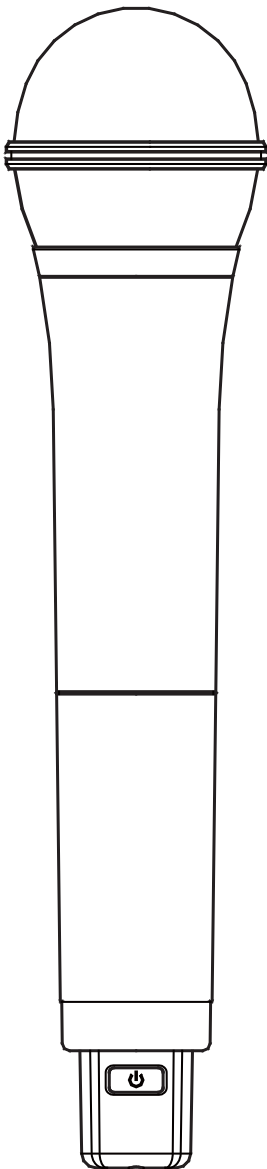

WIRELESS MICROPHONE SYSTEM

Table of contents	Page
● Introduction	1
- FCC Statement	
- Safety	
- Environment	
● Product Description	2
- Receiver	
- Handheld Microphone	
- Bodypack transmitter	
● System Operation	6
- Connecting the Receiver	
- Set up the Handheld Microphone / Bodypack transmitter	
● Trouble Shooting	8
● System Feature	8
● System Specification	9

● Introduction

Thank you for purchasing our product. This PLL synthesized wireless microphone system operates in UHF band frequency with 16 selectable channels. Please read this instruction manual carefully before operating the system. This manual covers the function and operation of the wireless microphone system.

◆ FCC Statement

This device complies with part 15 of the FCC rules. Operation is subject to the following two conditions: (1) This device may not cause harmful interference and (2) This device must accept any interference received, including interference that may cause undesired operation

Notice : The changes or modifications not expressly approved by the party responsible for compliance could void the user's authority to operate the equipment.

IMPORTANT NOTE: To comply with the FCC RF exposure compliance requirements, no change to the antenna or the device is permitted. Any change to the antenna or the device could result in the device exceeding the RF exposure requirements and void user's authority to operate the device.

◆ Safety

- Do not spill liquid on the appliance and do not drop it on a hard concrete floor.
- Do not place the equipment near heat sources such as radiators, heating ducts, amplifier, etc.
- Do not expose the equipment to direct sunlight, extremely dust, excessive moisture, rain, mechanical vibrations, or shock.
- Take out the battery from transmitter, if the appliance has been not used for a longer period. This will avoid the damage resulting from a defective leaking battery.
- If the equipment is not going to be used for a long time, disconnect the AC adapter from the power outlet. Please note that if you turn the equipment off while leaving the AC adapter plugged in, it is not fully isolated from the power supply.
- **WARNING:** To reduce the risk of fire or electric shock, do not use the products near water and do not expose them to rain or moisture.
- No guarantee claims for the equipment and no liability for any resulting personal damage or material damage will be accepted if the equipment are used for other purpose than originally intended, if the equipment are not correctly connected or operated, or if the equipment are not repaired in an expert way.

◆ Environment

- Do not throw used batteries into a fire or garbage bin with domestic rubbish. Be sure to dispose of used batteries in accordance with local waste disposal rules.
- When disposing the equipment, remove the batteries, separate the case, circuit boards, and cables, and dispose of all components in accordance with local waste disposal rules.

● Product Description

➤ Receivers

The receivers are used with our 16-channel selectable channels transmitters. (The number of frequency channels depends on local regulations.) The receiver operates in UHF band frequency with PLL synthesized control. Powered by 12V DC.

➤ Single Channel

Switching Diversity, Front Fixed Antenna

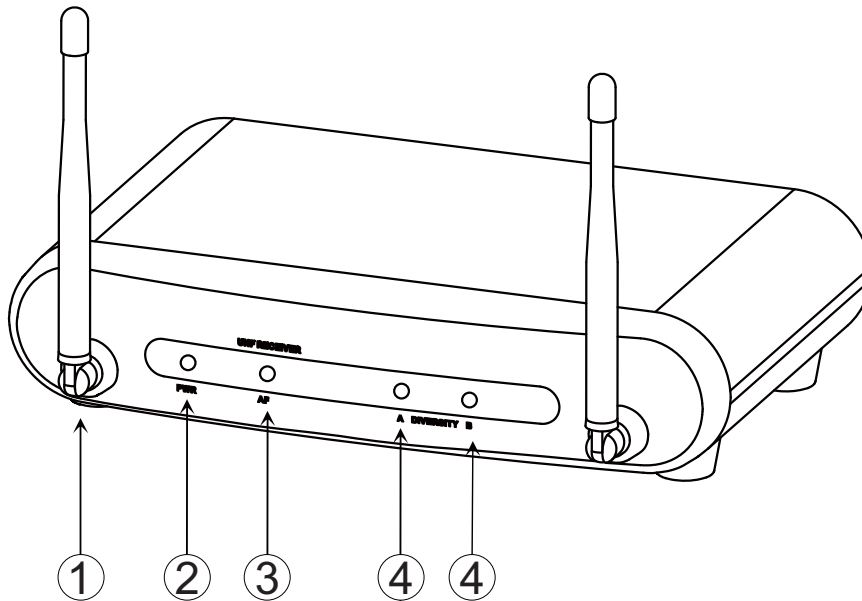

1. Antenna

2. **Power Indicator:** The LED lights up to show the receiver is ready to operate.

3. **AF Indicator:** The LED lights up to show the reception of AF signal.

4. **Diversity A/B Indicator:** The LED lights up to show the reception of RF signal.

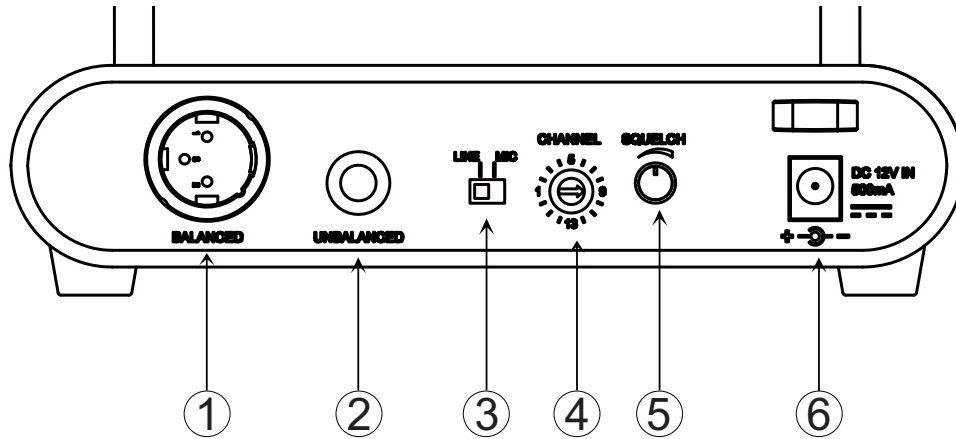

1. **Balanced XLR Audio Output**
2. **Unbalance 6.35mm Audio Output**
3. **MIC/LINE Switch:** Use this to adjust the audio output level for MIC level (-20dB) or LINE level (0dB).
4. **Squelch:** Turn the switch to adjust or decrease the noise floor level.
5. **Power Adapter Connector**

➤ **Handheld Microphone**

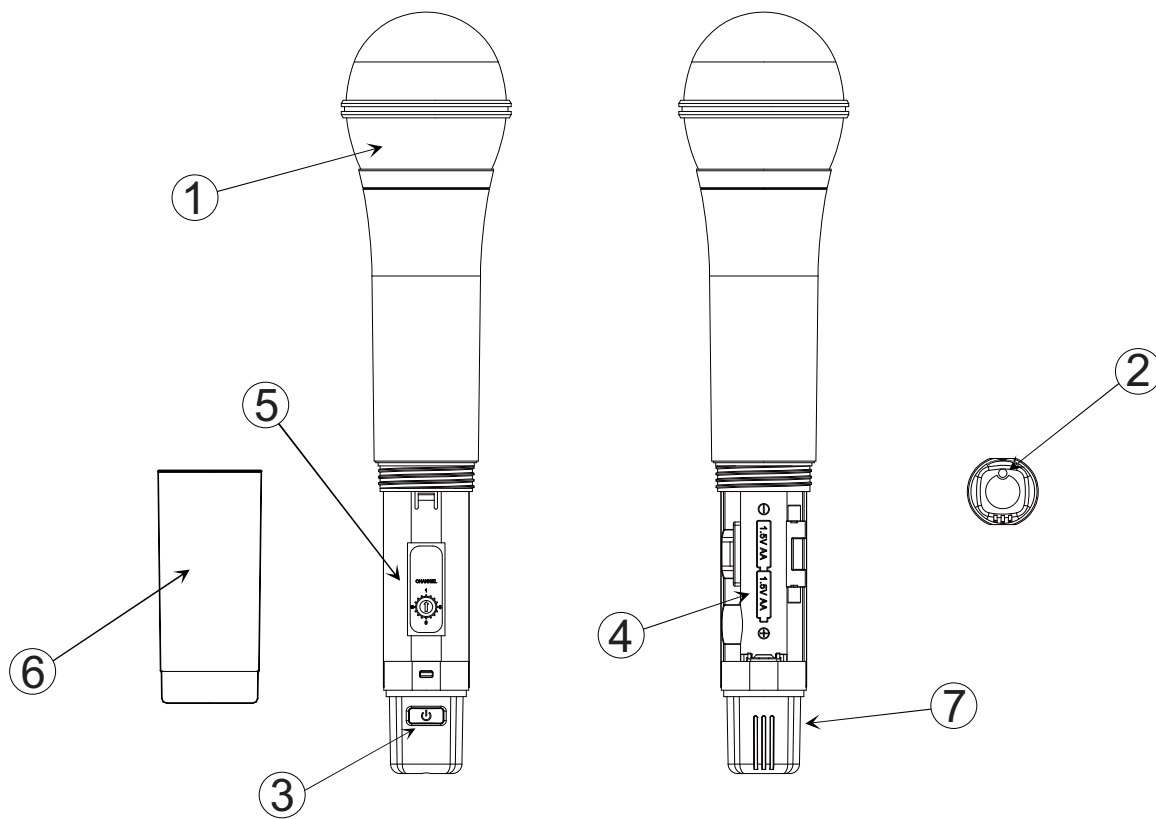

1. **Grille:** Protects the microphone capsule and helps reduce breath sounds and wind noise. The grille for the various microphone capsules differ in appearance.
2. **Power LED:** Indicate the power / low battery level status.

LED Indicator	Status
Red	Ready
Flashing Red	Low Battery power when less than 10 minutes operation

3. **Power:** Press for 2 seconds to turn transmitter on or off.
4. **Battery Compartment:** Insert two AA dry or rechargeable batteries into the compartment and make sure that the polarity of batteries is correct.
5. **Channel Selector:** 16 different selectable frequencies.

➤ **Bodypack Transmitter**

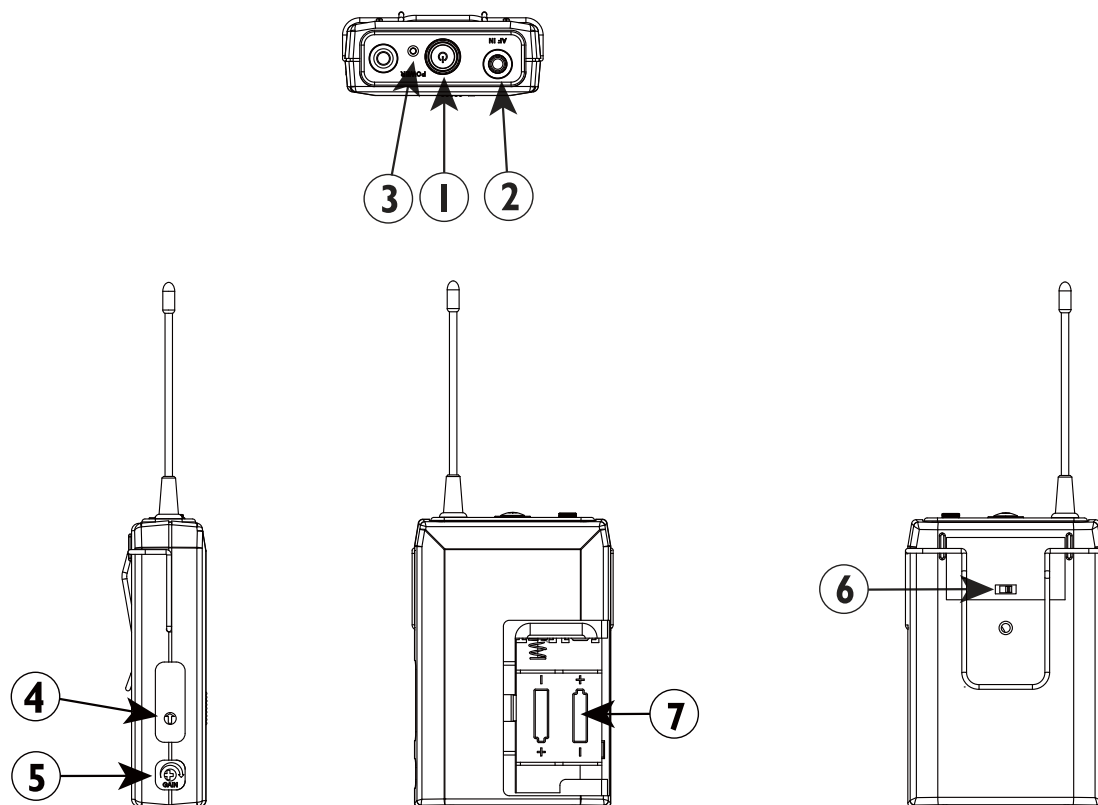

1. **Power / MUTE Button:** Press for 2 seconds to power the microphone on or off. With the transmitter on, a slight press for button will toggle between mute and unmute function.
2. **3.5Ø Connector:** connect to the lapel microphone or headset microphone.
3. **Power / MUTE LED:** Indicate the power / mute / low battery level status.

LED Indicator	Status
Red	Ready
Flashing Red	Low Battery power when less than 10 minutes operation
Blue	MUTE
Flashing Blue	MUTE on and low battery power when less than 10 minutes operation

4. **Channel Selector:** Changes the transmitter Channel setting.
5. **Gain Switch:** The rotary control adjusts the input audio level of the transmitter. The gain adjustment range is 10dB.
6. **MIC/LINE Switch:** The switch set the audio input to MIC level or LINE level.
7. **Battery component:** Insert two AA dry or rechargeable batteries into the compartment and make sure that the polarity of batteries is correct.

● **Connecting the receiver**

Prior to setting up, please check that the transmitter and receiver are tuned to the same frequency or channel. Two or more transmitters operating in the same frequency can not be used at the same time and area.

1

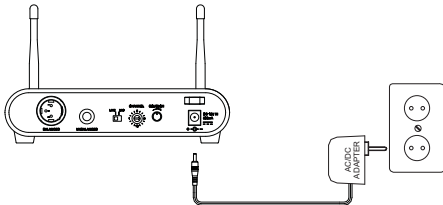

- Connected the provided DC power supply to the receiver power input with an appropriate AC power source. The power LED display will light and the receiver is on.

2

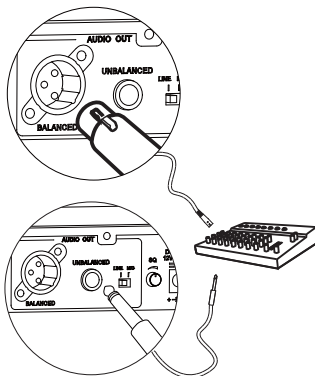

- Using a standard audio cable with 3-pin XLR connectors or 6.3mm phone plugs to connect the mixer or amplifier.
- ✧ Never use the balanced and unbalanced audio outputs at the same time! This may cause signal loss or increased noise.

3

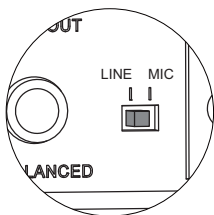

- Set the audio output level for
MIC: -20dB
LINE: 0dB

4

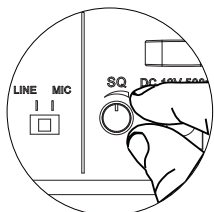

- Use squelch to avoid reproducing noise when the receiver does not receive enough signal from the transmitter.
 - Turn clockwise to increase squelch and reduce noise. When turning the squelch knob clockwise, it begins to eliminate background noise.
 - When the squelch is all the way to the left, the squelch is off and the ambient RF noise will be easily to receive.

● **Set up the handheld microphone / bodypack transmitter**

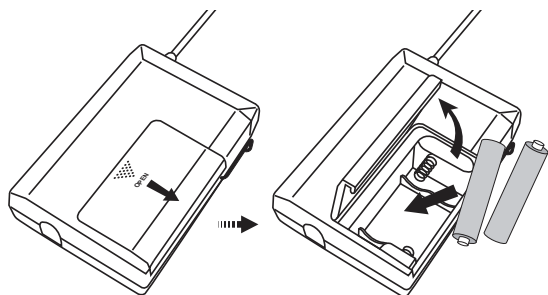

- Open the battery cover and insert batteries into the battery compartment conforming to the polarity (+)(-) marks.

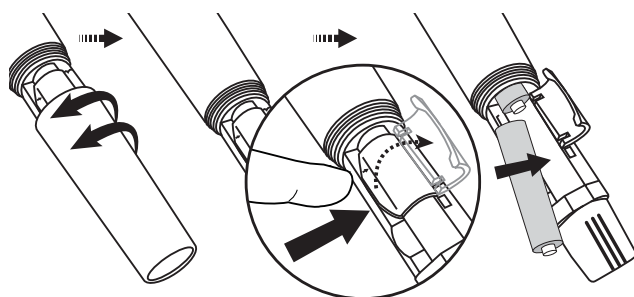

- Unscrew the handheld Mic and open the battery cover to insert the battery into the battery compartment and confirm the marks of the polarity (+) (-).

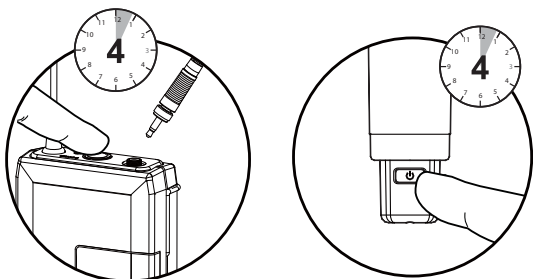

- Press for 4 seconds to turn the Handheld/ Bodypack transmitter on.
- ✧ If the LED stays flashing, it indicates that the battery will run out of power soon and should be changed.

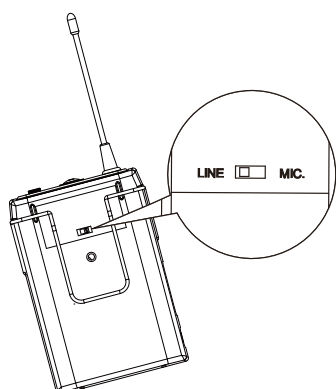

- Adjust the audio input level.
 - MIC : 0dB
 - LINE : -20dB

NOTE: When you don't use this device for a long term period, please switch the power switch to "off" mode to save more electric power.

● Troubleshooting

Problem	Solution
No sound	<ul style="list-style-type: none">➤ Check the power supply of the microphone and receiver.➤ Check that the transmitter and receiver are tuned to the same frequency.➤ Check whether the hi-fi appliance is switched on and the receiver output is connected to audio mixer or amplifier input.➤ Check whether transmitter is too far away from receiver or SQUELCH control set too high.➤ Check whether receiver is located too near metal object or there are obstructions between transmitter and receiver.
Sound interference	<ul style="list-style-type: none">➤ Check the antenna location.➤ When using 2 or above microphone sets simultaneously, make sure that the chosen frequencies are not interfered.➤ Check whether the interference comes from other wireless microphones, TV, radio and etc.
Distortion	<ul style="list-style-type: none">➤ Check the receiver volume level is set too high or too low.➤ Check whether the interference comes from other wireless microphones, TV, radio and etc.

● System Feature

- Operating in UHF band frequency with synthesizer controlled.
- The wireless microphone system with 16 selectable frequencies via Phase Locked Loop (PLL) circuitry makes it easy to choose non-interfered channels.
- Diversity with two antennas to ensure the reception quality.
- Super high sensitivity, extremely low noise transmission and reception.
- SMT assembled PCB module ensures the quality and stability.

● System Specification

Receiver

- Carrier Frequency Range : UHF 520 - 698MHz
- Case : Mini case
- Oscillator : PLL Synthesized
- Modulation : FM ± 20 KHz
- Frequency Stability : $\pm 0.005\%$
- S/N ratio : > 100 dB, at 20KHz deviation and 60dB μ V antenna input
- Image and Spurious Rejection : 80 dB minimum
- Receiving Sensitivity : At 3 μ V over 52dB/A S/N ratio
- Selectivity : > 50 dB
- AF Response : 80Hz to 18KHz
- T.H.D. : $< 1\%$ (at 1KHz)
- IF Frequency : 1st: 243.95MHz 2nd:10.7MHz
- Dynamic Range : > 100 dB
- Tone Signal : 32.768KHz
- Audio Output : Balanced & Unbalanced
- Power Supply : DC 12V
- Current Consumption : 120mA \pm 10mA
- Dimension (mm)W×H×D : 170×42×106

Handheld Microphone/Bodypack Transmitter

- Frequency Range : UHF 520 - 698 MHz
- Channel Select : Rotary switch
- RF Power Output : 10mW (MAX)
- Oscillator : PLL Synthesized
- Frequency Stability : $\pm 0.005\%$
- Deviation : ± 20 KHz with limiting compressor
- Spurious Emission : > 60 dB below carrier frequency
- T.H.D. : $< 1\%$ (at 1KHz)
- Battery : 1. DC 2.4V (1.2V x 2 AA size rechargeable batteries)
2. DC 3V (1.5V x 2AA size batteries)
- Tone Key : 32.768KHz
- Mic Unit : Handheld : Uni-directional dynamic unit
Uni-directional electret condenser unit
Bodypack : Lavalier Mic / Headset Mic
- Current Consumption : 120mA \pm 10mA
- Dimension (mm)W×H×D : Handheld : 237×56 ϕ
Bodypack : 65×100×27

DESIGN AND SPECIFICATIONS SUBJECT TO CHANGE WITHOUT NOTICE.

FCC Caution: To assure continued compliance, any changes or modifications not expressly approved by the party responsible for compliance could void the user's authority to operate this equipment. (Example - use only shielded interface cables when connecting to computer or peripheral devices).