

Mastercraft® MD

TABLE SAW WITH SLIDING TABLE

055-6742-8

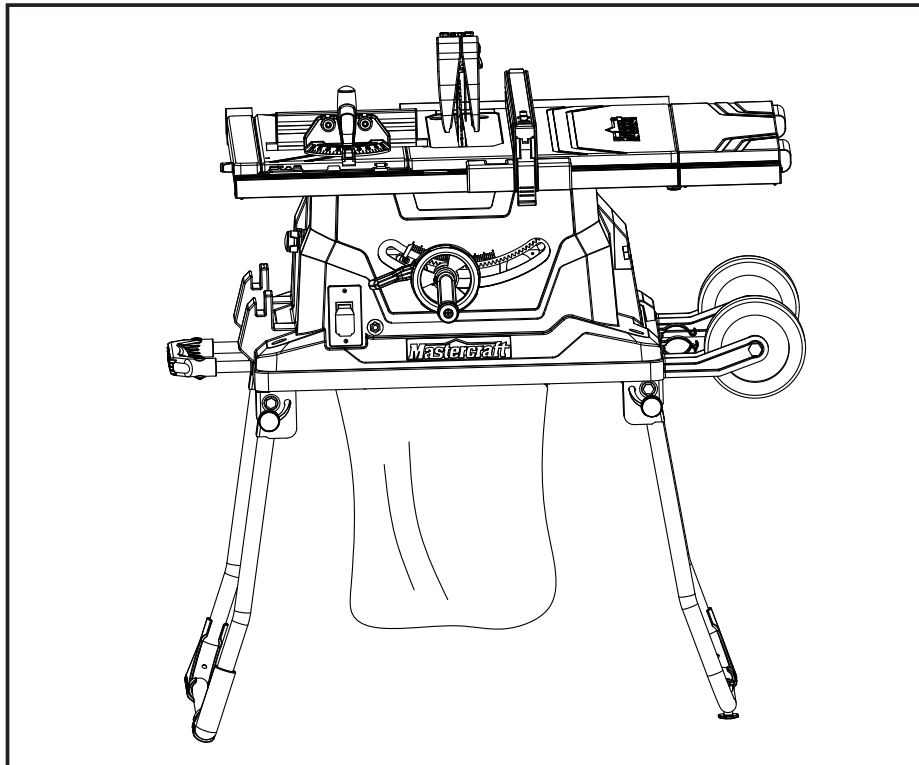

User Manual

**Toll-free helpline
1-800-689-9928**

Table of contents

SECTION	PAGE
I. Specifications.....	2
II. General safety guidelines	3
III. Electrical information	7
IV. Know your table saw.....	8
V. Assembly and adjustments.....	9
VI. Operating instructions	23
VII. Maintenance.....	30
VIII. Troubleshooting guide.....	32
IX. Warranty.....	33
X. Part list	34

I. Specifications

Motor:	120 V, 60 Hz, 15 A,
Speed:	4500 RPM (no load)
Blade:	10" (25.4 cm) carbide-tipped
Right extension table:	19 11/16 x 6 1/10" (50 x 15.5 cm)
Main table size:	26 1/2 x 19 11/16" (67.3 x 50 cm)
Rear table size:	26 1/2 x 2 1/2" (67.3 x 6.4 cm)
Sliding tale size:	8 2/3" x 19 11/16" (22 x 50 cm)
Laser:	Class IIIA
Laser wavelength:	630–665 nm
Laser outpower:	<5 mW
Net weight:	75 lb (34 kg)
Depth of cut at 90°:	3 9/64" (8 cm)
Depth of cut at 45°:	2 5/32" (5.5 cm)

II. General safety guidelines

WARNING: Read all the safety guidelines and instructions before you use this electric power tool!

WARNING! When using electrical power tools, the following essential safety measures have to be observed to prevent electric shocks, injury and fire hazards. Failure to adhere to the safety guidelines and instructions can cause electric shock, fire and/or severe injuries.

1. Store all safety guidelines and instructions for future use.
2. This device is not intended for use by people (including children) lacking experience with electrical power tools unless they have received instructions about how the device is to be used. Children have to be supervised to ensure that they do not play with the device.
3. Store the operating instructions so that they are always available to the user of the tool when it is being operated.
4. If you lend this device to other people, then always hand over these operating instructions to ensure safe use. Instruct inexperienced people in accordance with these safety instructions.
5. Keep your working area tidy. Untidiness in your work area can cause accidents.
6. Pay attention to the surrounding conditions. Do not expose the electric power tool to rain. Do not use electric power tools in damp or wet conditions. Ensure that the work area is well lit. Do not use electric power tools where there is a danger of fire or explosion.
7. Protect yourself against electric shocks. Avoid bodily contact with earthed parts (e.g. pipes, radiators, electric hobs or cooling appliances).
8. Keep other people away from the work area. Do not let other people, especially children, touch the electric power tool or the power cable. Keep them away from your work area.
9. Store unused electric power tools safely. Unused electric power tools should be stored in a dry, high-lying or locked place, out of the reach of children.
10. Do not overload your electric power tool. It works better and more securely within the stated output range.
11. Use the correct electric power tool. Do not use inefficient machines for heavy work. Do not use the electric power tool for purposes which it was not intended for. For example, do not use circular saws to cut wooden masts or logs.
12. Wear suitable clothing. Do not wear baggy clothing or jewellery, as they can be caught by moving parts. When working outdoors, anti-slip shoes are recommended. If you have long

II. General safety guidelines(continued)

hair, wear a hair net.

13. Wear safety equipment. Wear safety goggles. If the work creates dust, wear a dust mask.
14. Attach the dust extraction unit. If there are connections for dust extraction and collection equipment, then make sure that the equipment is correctly attached and used.
15. Never use the cable for purposes which it is not intended for. Do not use the cable to pull the plug out of the power socket. Protect the cable from heat, oil and sharp edges.
16. Secure the workpiece, when necessary use clamping devices to secure the workpiece. The workpiece is thereby secured better than by hand.
17. Avoid taking abnormal stances. Make sure you stand securely and keep your balance at all times.
18. Look after your tool with care. Keep the cutting tool sharp and clean so that you are able to work better and safer with it. Observe the guidelines on lubrication and exchanging the tool. Check the power cable of the electric power tool regularly and in case of damage let a recognized specialist repair it. Check extension cables regularly and replace them if they are damaged. Keep the handles dry, clean and free of oil and grease.
19. Pull the plug out of the power socket when the electric power tool is not in use, before maintenance and when exchanging tools such as saw blades, drills and mills.
20. Do not leave keys in the device. Before you switch the device off, check that keys and setting tools have been removed.
21. Avoid starting-up the device accidentally. Make sure that when you insert the plug into the power socket, the power switch is turned off.
22. Use an extension cable when working outdoors. Only use extension cables outdoors which are authorized for outdoor use and are correspondingly marked.
23. Be attentive. Be careful what you do. Carry out your work sensibly.
24. Check the electric power tool for any sign of damage. Before continuing work with electric power tool, safety devices or easily damaged parts have to be carefully checked to ensure that they function properly and are not defective. Check that the moving parts are working properly and are not jammed, or whether the parts are damaged. All parts must be correctly assembled by an experienced individual, unless stated otherwise in the operating instructions, and meet all required conditions in order to guarantee that the electric power tool functions without a problem. Damaged switches have to be replaced by a qualified electrician. Do not use electric power tools if the power switch cannot be turned on and off.

II. General safety guidelines(continued)

25.**WARNING!**The use of other insertion tools and accessories can present a danger of injury to you.

26.Let a specialist electrician repair your electric power tool. This electric power tool corresponds to the applicable safety conditions. Repairs are only allowed to be carried out by a specialist electrician, using original replacement parts; otherwise accidents may occur.

Additional safety guidelines for circular table saws

27.No other people are allowed to stand in the direct vicinity of the machine when it is in use. People not operating the machine must maintain a suitable safe distance!

28.Never lay the power cable over the machine table!

29.Use the push rod to pass the workpiece safely into the saw blade! Do not come too close to the saw blade!

30.Make sure that the thickness of the material to be cut is less than the maximum possible cutting depth.

31.Never cut “hands-free”! The workpiece must always lie level on the machine table and be moved along the stop! The workpiece must always be pressed hard against the stop!

32.Never cut workpieces that are so small that they cannot be safety pressed against the stop and could turn!

33.Never cut workpieces that are so small that they cannot be moved by the push rod at a safe distance from the saw blade!

34.Only cut one workpiece at a time! Never cut several workpieces simultaneously! Workpiece are not allowed to be placed behind or on top of each other!

35.There is a danger of the workpiece “jamming” and slipping away!

36.Make sure that the workpiece cannot slip while cutting or get jammed in the saw blade!

37.Clean the working area and the workpiece after each cut.

Warning! Switch the device off, remove the plug from the power socket and let the machine come to a standstill! No foreign bodies are allowed to be on the workpiece or the machine table! Cut pieces of the workpiece can be caught by the rotating cutting disc and be flung away!

II. General safety guidelines(continued)

- 38.Never reach into the openings of the device! Never insert objects into the openings of the device (e.g. the saw blade casing, dust extraction adaptor). Danger of cuts!
- 39.Never remove the cutting piece if the machine is still switched on or running! Danger of cutting yourself!
- 40.Cut workpieces may have sharp edges, ridges or wooden splinters! Danger of cutting injuries!
- 41.Always switch the machine off and remove the power plug when your leave the machine.
- 42.Never expose the device to rain or extreme moisture!
- 43.Do not perform any cuts with this circular table saw, other than those described in these operating instructions! Seams and notches are not allowed to be sawn!
- 44.Circular saws are not allowed to be used for slitting (notches which end in the workpiece)!

KEEP THIS USER'S MANUAL IN A SAFE PLACE FOR FUTURE REFERENCE.

III. Electrical information

GUIDELINES FOR USING EXTENSION CORDS

WARNING: THIS TABLE SAW IS INTENDED FOR INDOOR USE ONLY. DO NOT EXPOSE IT TO RAIN OR USE IT IN DAMP LOCATIONS.

Make sure the extension cord is in good condition. When using an extension cord, be sure to use one that is heavy enough to carry the current that your product will draw. An undersized cord will cause a drop in line voltage, which will result in loss of power and overheating. The table below shows the correct size to be used according to cord length and nameplate ampere rating. When in doubt, use the next heavier gauge. The smaller the gauge number, the heavier the cord.

MINIMUM GAUGE FOR EXTENSION CORDS(AWG) (when using 120 V only)					
Ampere Rating		Total length of cord in feet (metres)			
More Than	Not More Than	25' (7.6 m)	50' (15.2 m)	100' (30.5 m)	150' (45.7 m)
0	6	18	16	16	14
6	10	18	16	14	12
10	12	16	16	14	12
12	16	14	12	Not Recommended	

Make sure your extension cord is properly wired and in good condition. Always replace a damaged extension cord, or have it repaired by a qualified person before using it. Protect your extension cords from sharp objects, excessive heat, and damp or wet areas.

Use a separate electrical circuit for your tools. This circuit must consist of not less than #12 wire with a 20 A time-delayed fuse or a #14 wire with a 15 A time-delayed fuse. Before connecting the motor to the power line, make sure the switch is in the OFF position and the electric current is rated the same as the current stamped on the motor nameplate. Running at a lower voltage will damage the motor.

WARNING: THIS TOOL MUST BE GROUNDED WHILE IN USE IN ORDER TO PROTECT THE OPERATOR FROM ELECTRIC SHOCK.

IV. Know your table saw

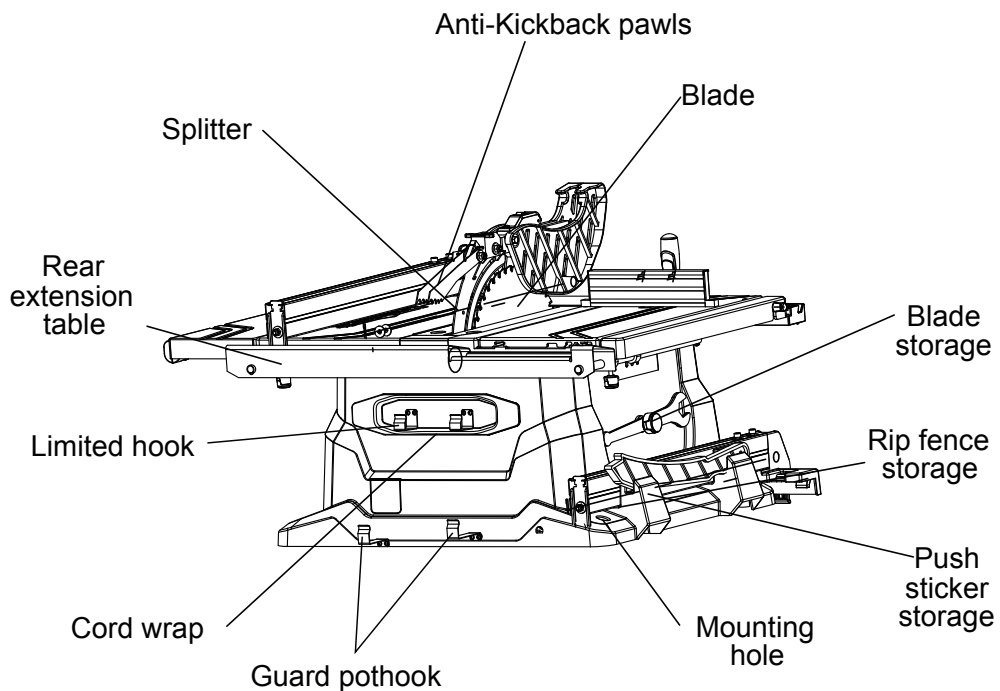
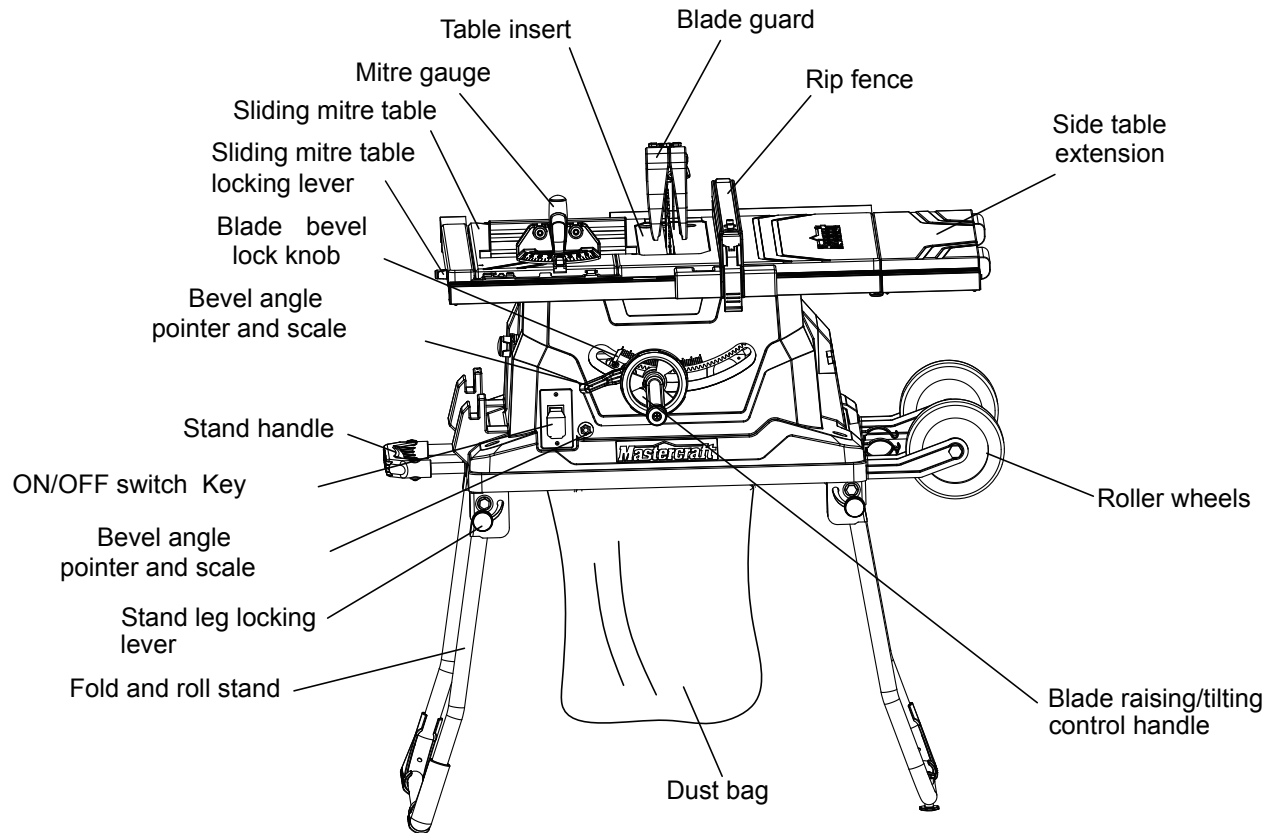

V. Assembly and adjustments

UNPACKING

1. Carefully remove the table saw from the carton.
2. Separate the parts.
3. Lay out all of the parts, and check them against the parts listed below. Examine all of the parts carefully.

WARNING:

- IF ANY PART IS MISSING OR DAMAGED, DO NOT PLUG THE TABLE SAW IN UNTIL THE MISSING OR DAMAGED PART HAS BEEN REPAIRED OR REPLACED.
- FOR MORE INFORMATION, CALL THE TOLL-FREE HELPLINE AT 1-800-689-9928.

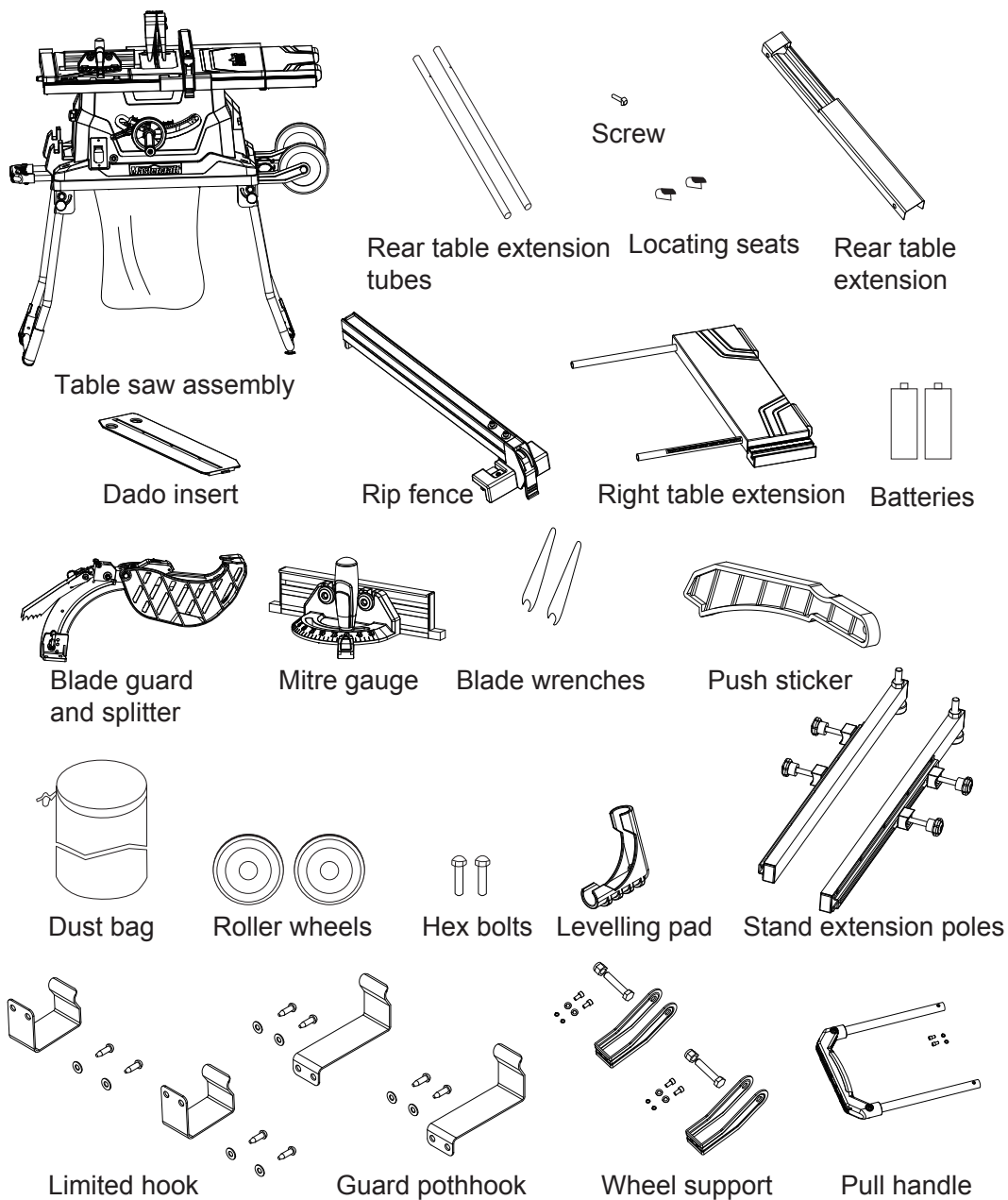

V. Assembly and adjustments (continued)

INSTALLING THE BATTERIES FOR THE LASER LINE (FIG. 1)

1. Uninstall the blade guard component by loosening the handle (1). Remove the locking screw (2) on the battery box cover with a screwdriver, and open the battery compartment.
2. Install two “AAA” batteries.
3. Install the battery box cover by closing the screw (2), tighten it securely.
4. Turn the switch (3) to the ON position in order to activate the laser cutting guide.

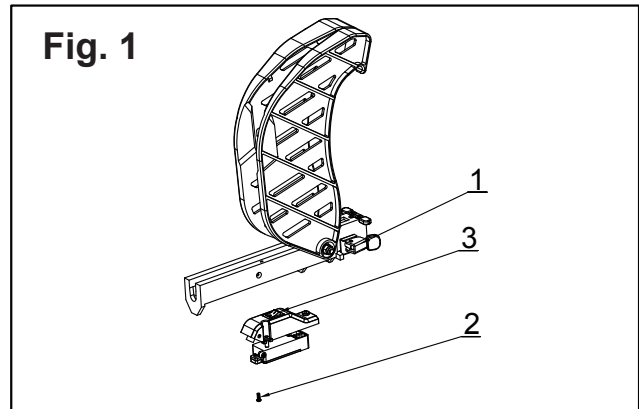

THE LASER LINE

This tool is equipped with a Hawkeye Laser Line, which is a battery-powered laser cutting guide. The laser line allows the operator to anticipate the path of the saw blade on the workpiece before beginning cutting.

WARNING: The laser beam is emitted when the laser line is turned on. Do not stare into the beam or view it directly using optical instruments. Do not remove the warning label that is affixed to the laser cover. Avoid aiming the laser beam directly into the eyes. Caution-use of controls or adjustments or performance of procedures other than those specified herein may result in hazardous radiation exposure.

CAUTION-The use of optical instruments with this product will increase eye hazard.

NOTE

- A laser beam is not a toy, and it should not be used by children. Misuse of the laser line can lead to irreparable eye damage.
- strongly recommend the use of laser protective eyewear for the specific wavelength of emitted light when working on or near reflective surfaces.
- Do not perform any adjustments that are intended to increase the power of the laser.
- When using the laser line, do not point the laser beam at people and/or reflecting surfaces. Even a low-intensity laser beam can cause eye damage. Do not look directly into the laser beam.
- If the laser line will not be used for more than three months, remove the batteries in order to avoid damage from possible leakage.
- The laser line does not include any user-serviceable components. Do not open the housing in an attempt to repair it.
- Repairs should only be carried out at a service centre or by an authorized service technician.



V. Assembly and adjustments(continued)

CAUTION LASER RADIATION.

Do not stare into the beam or view it directly using optical instruments.
Maximum output: <5 mW Wavelength: 630-665 nm Protection Class: IIIA

Keep Work Areas Clean

- Accumulated sawdust and wood chips can pose a safety hazard.
- Pick up and dispose of accumulated sawdust and debris before each cutting operation.

WARNING: KEEP THE WORK AREA CLEAN, UNCLUTTERED, AND WELL-LIT. DO NOT WORK ON A FLOOR SURFACE THAT IS SLIPPERY FROM ACCUMULATED SAWDUST, DEBRIS OR WAX.

ASSEMBLING THE BLADE RAISING/ TILTING CONTROL HANDLE (FIG. 2)

Attach the blade tilting wheel (1) into the fix pole (3). Assemble the height adjustment rock (2) to the height regulating bolt (3). Use the screw and washer to lock the height adjustment rock.

RIP FENCE (FIG. 3)

1. Lift the rip fence handle (1) until the rear holding clamp (2) is fully extended.
2. Place the rip fence on the saw table, lowering the front of the fence onto the table first.
3. Push down on the fence handle (1) in order to lock the rip fence in position.

Fig. 2

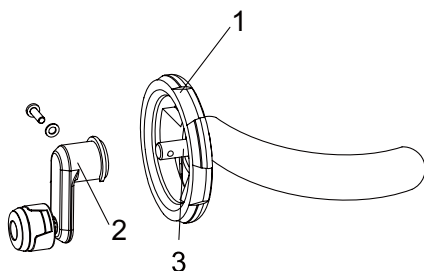
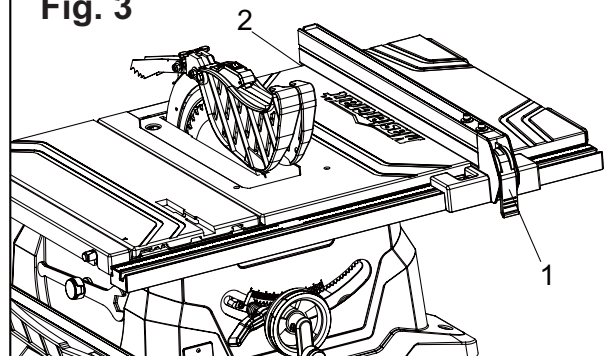

Fig. 3



WARNING: IN ORDER TO AVOID INJURY FROM AN ACCIDENTAL START-UP, VERIFY THAT THE POWER SWITCH IS IN THE "OFF" POSITION, THAT THE SAFETY KEY IS REMOVED, AND THAT THE POWER CORD IS NOT PLUGGED INTO THE OUTLET. IN ORDER TO AVOID SERIOUS INJURY, THE REAR OF THE TABLE INSERT MUST BE FLUSH WITH THE TABLE DURING ALL SAWING OPERATIONS. A RUBBER ADJUSTING SPACER IS PROVIDED UNDER THE REAR OF THE INSERT FOR THIS PURPOSE.

V. Assembly and adjustments(continued)

INSTALLING THE BLADE TO THE ARBOR (FIG. 4, 5, 6)

1. Remove the table insert(1)by inserting the finger into the hole (2&3) (see Fig.4).
2. Raise the saw blade arbor (4) to its maximum height by turning the blade raising control handle counter-clockwise. Remove the arbor nut (5) and the outer flange (6) from the saw arbor.
3. Place the saw blade onto the arbor, with the teeth of the blade pointing DOWN toward the front of the saw.
4. Place the flange (6) and the arbor nut (5) onto the arbor, and hand-tighten the nut. Verify that the saw blade is firmly seated against the inner flange (7) (Fig. 5).
NOTE: Verify that the large, flat surfaces of the flange and the nut face INWARD, toward the saw blade.
5. Place the open-ended blade wrench (8) on the flat of the outer flange (6) in order to prevent the arbor from turning while tightening. Tighten the arbor nut by turning it clockwise using the box-end blade wrench (9) (Fig. 6).

Fig. 4

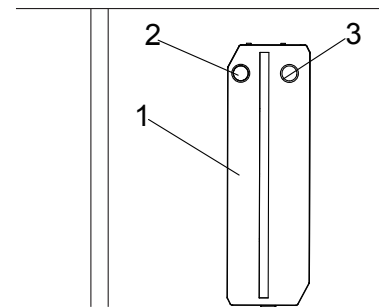

Fig. 5

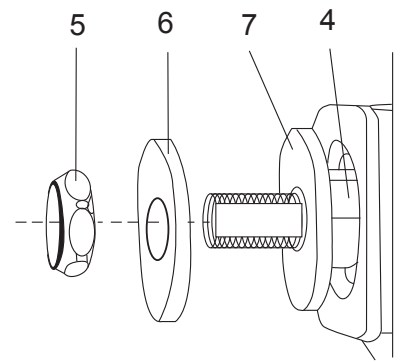
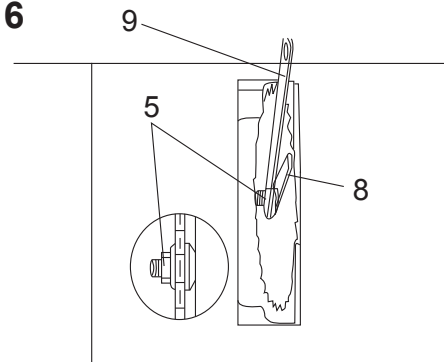

Fig. 6



WARNING: VERIFY THAT THE SAW BLADE, THE ARBOR FLANGE, AND THE NUT ARE PROPERLY SEATED, AND THAT THE ARBOR NUT IS TIGHTENED SECURELY.

WARNING: IN ORDER TO AVOID INJURY FROM AN ACCIDENTAL START-UP, VERIFY THAT THE POWER SWITCH IS IN THE "OFF" POSITION, AND THAT THE POWER CORD IS NOT PLUGGED INTO THE OUTLET.

V. Assembly and adjustments(continued)

ASSEMBLING THE BLADE GUARD (Fig. 7, 8 & 9)

VERIFY THAT THE SAW IS DISCONNECTED FROM THE OUTLET BEFORE INSTALLING THE BLADE GUARD AND SPLITTER ASSEMBLY.

1. Use the handwheel to set the blade to the maximum height and to set the tilt to 0° on the bevel scale. Lock the blade bevel locking knob.
2. After loosening the knob (6), press the device (5), the splitter (7) should be at the highest position (Fig. 7)
3. Insert the blade guard assembly (1) into the splitter bracket, as shown. (Fig. 8)
4. Using a straight edge (2), verify whether the blade guard splitter (3) is aligned with the saw blade (4), with the straight edge lying between the teeth of the blade. (Fig. 9)

NOTE: The blade guard and splitter must always be correctly aligned so that the cut workpiece will pass on either side of the splitter without binding or twisting to the side.

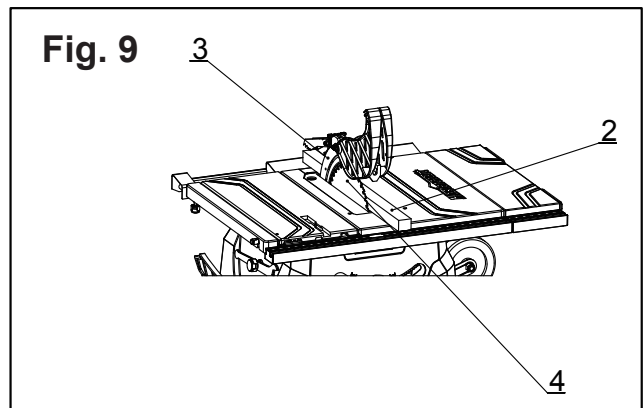
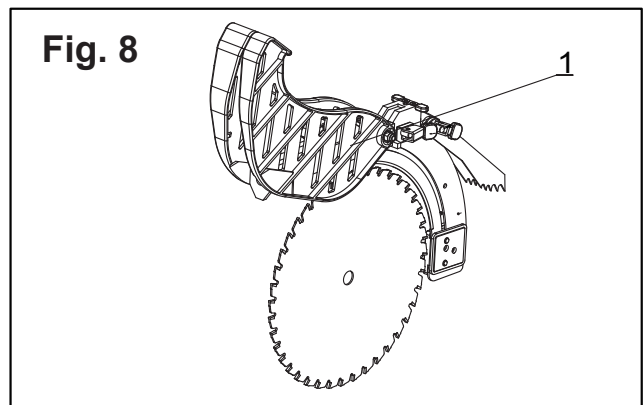
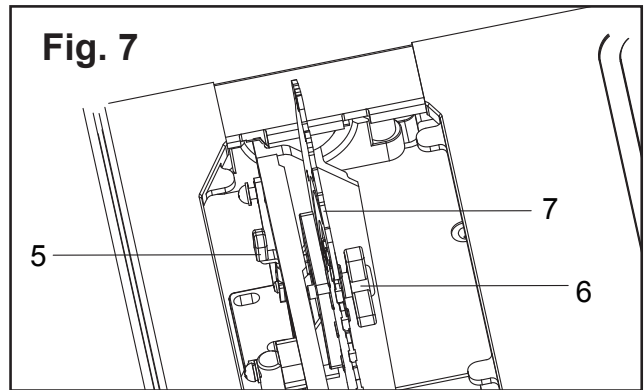

WARNING: Improper alignment of the splitter can cause “kickback” and serious injury.

V. Assembly and adjustments(continued)

ASSEMBLING THE TABLE EXTENSION WING (FIG. 10, 11)

NOTE:

- A. Install the extension component (1) (2) into the two holes at the side of the main table. (Fig. 10)
- B. Install the locking knobs (3) on the aluminum extension wing. (Fig. 11)

ADJUSTING THE TABLE EXTENSION WING (FIG. 11)

Follow these steps to adjust the position of the extension table

1. Unlock the locking knobs (3) on the two extension tube brackets.
2. Slide the extension tubes in or out, until the scale on the front tube is positioned at the desired distance. Lock the locking knobs (3)

Fig. 10

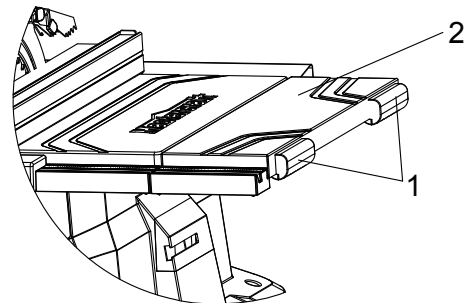
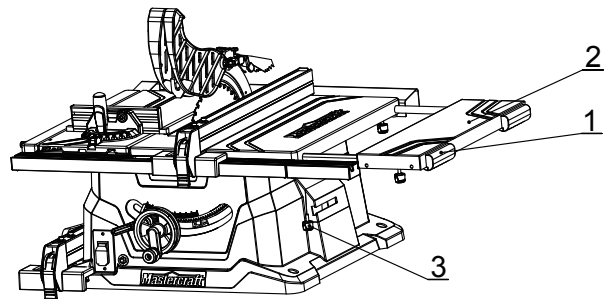

Fig. 11



WARNING:In order to avoid injury from an accidental start-up, verify that the power switch is in the "OFF" position, and that the power cord is not plugged into the outlet.

INSTALLING THE MITRE GAUGE (FIG. 12)

1. Position the mitre body (2) at 90°, and tighten the handle (3) in order to secure the mitre body in position.
2. Place the mitre gauge into the slot (4) of the sliding mitre table (5).
3. Release the locking bolt (1) before using the sliding mitre table.

Fig. 12

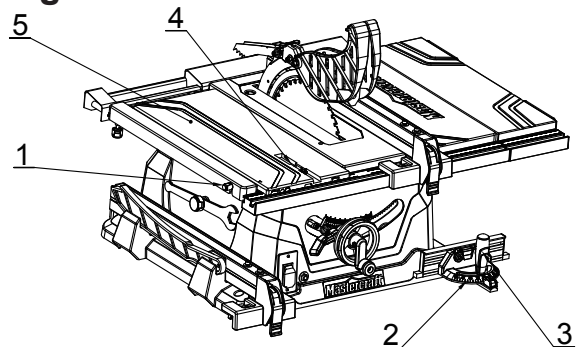

V. Assembly and adjustments(continued)

ADJUSTING THE MITRE GAUGE (FIG. 13)

1. Loosen the locking handle (1) in order to allow the mitre body (2) to rotate freely (Fig. 13). Position the mitre body at 90° so that the positive detent secures it in position. Tighten the locking handle in order to hold the mitre body securely in position.
2. If the pointer (3) requires adjustment, loosen the screw that is located under the pointer using a screwdriver. Adjust the pointer to 90° on the scale, and then tighten the adjusting screw firmly.
3. In order to change the angle of the mitre gauge, loosen the locking handle (1) and the rotate the mitre body to the desired angle, as indicated on the scale. Tighten the locking handle in order to hold the mitre body securely in position.

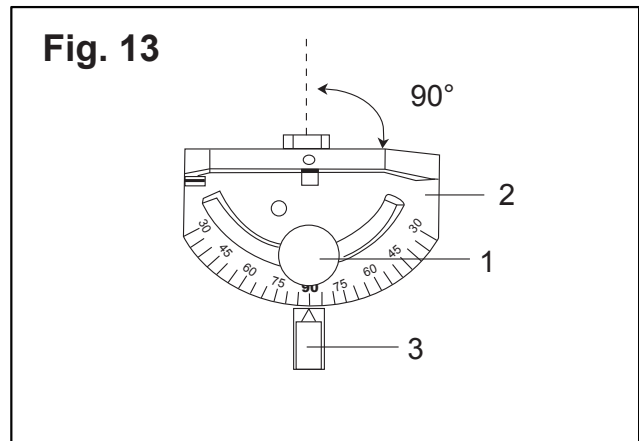

INSTALLING THE REAR TABLE EXTENSION (FIG. 14)

1. Place the rear table extension onto the two rear table extension tubes (1).
2. Snap the two locating seats (2) over the two rear table extension tubes (1). Verify that the locating pin in the locating seat fits into the corresponding hole in the extension tube.
3. Insert the rear table extension tubes (1) into the two holes in the rear of the saw table, and into the extension tube brackets that are located under the table. Position the rear table support so that the instruction labels are facing up.
4. Tighten one extension wing stop screw (4) on the end of the left rear table extension tubes (1). Verify that the screw is fully inserted into the corresponding hole (3) in the extension tube.

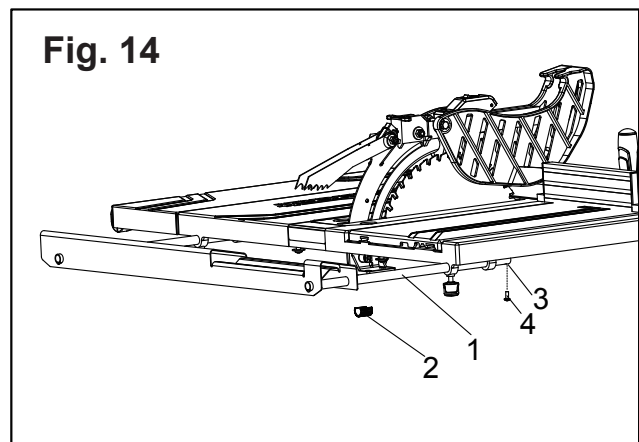

ADJUSTING THE REAR TABLE EXTENSION

1. When ripping a short workpiece, the rear extension table should be positioned as close to the rear of the main table as possible.
2. When ripping a long workpiece that requires extra support as the cut is completed, the rear extension table should be pulled out as far as possible, until the locating seat prevents it from moving out any further.

V. Assembly and adjustments(continued)

ADJUSTING THE RIP FENCE (FIG. 15)

1. Move the rip fence (1) by releasing the handle (2) and sliding the fence to the desired location. Push the handle down in order to lock the fence into position.
2. Position the fence on the right side of the table, and along the edge of the mitre gauge groove.
3. Lock the fence handle. The fence should be parallel to the mitre gauge groove.
4. If adjustment is required in order to make the fence parallel to the groove, follow these steps:
 - Loosen the two bolts (3), and release the handle (2).
 - Hold the fence bracket (4) firmly on the front of the working table. Move the fence until it is parallel to the mitre gauge groove.
 - Push the handle down, and tighten both screws.
5. If the fence is loose when the handle is in the locked (down) position, follow these steps:
 - Release the handle (2) and turn the adjusting nut (5) clockwise until the fence can be locked on the table.
 - Do not over-tighten the adjusting screw. Otherwise it will cause the fence to come out of the table.

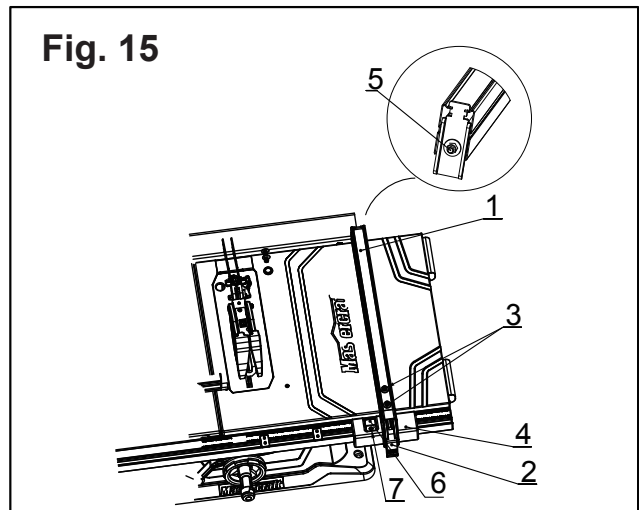

ADJUSTING THE RIP FENCE INDICATOR (FIG. 15)

1. The rip fence indicator (6) points to the measurement scale. The scale shows the distance from the side of the fence to near side of the blade.
2. Measure the actual distance using a ruler. If there is a difference between the measurement and the indicator, adjust the indicator (6).
3. Loosen the screw (7), and slide the indicator to the correct measurement on the scale. Tighten the screw, and re-measure using the ruler.

RAPID BLADE TILTING (FIG. 16)

1. Loosen the blade bevel locking knob (2).
2. Slide the entire control handle assembly (3) to the desired location.
3. Tighten the blade bevel locking knob (2). Verify that the locking knob is tightened securely before attempting a cut.

NOTE: The angle of the blade can be changed without changing the height of the blade,

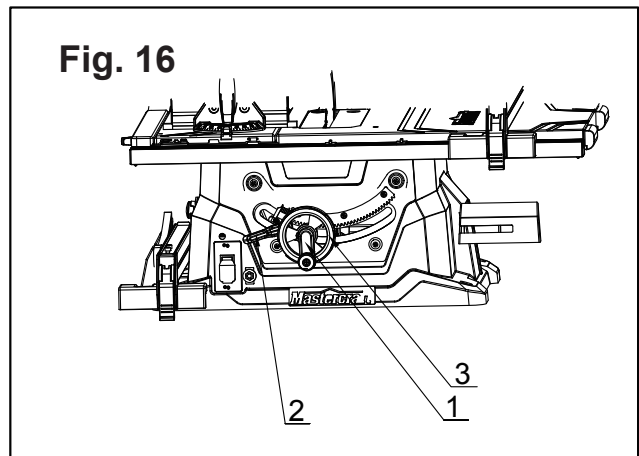

V. Assembly and adjustments(continued)

WARNING: THE BLADE BEVEL LOCKING KNOB (2) MUST BE TIGHTENED SECURELY AND LOCKED DURING ALL CUTTING OPERATIONS..

ADJUSTING THE BLADE HEIGHT (FIG. 16)

Turn the control handle (1) CLOCKWISE in order to raise the saw blade. Turn the control handle (1) COUNTER-CLOCKWISE in order to lower the saw blade.

NOTE: It is not necessary to loosen the blade bevel locking knob (2) in order to raise or lower the saw blade.

90°(0°) BEVEL STOP (FIG. 17)

1. Raise the blade to the maximum height by turning the control handle counter- clockwise.
2. Loosen the bevel angle locking knob.
3. Tilt the blade to the 90°(0°) bevel.
4. Using a square (1), verify that the blade is at a 90° (0°) angle to the table top.
5. If blade is not at a 90° (0°) angle to the table, back off the adjustment screw (2).
6. Loosen the bevel locking knob and square the blade 90° (0°) to the table.
7. Once the blade is at a 90° (0°) angle to the table top, tighten the bevel angle locking knob.
8. Carefully tighten the adjusting screw (2) until it touches the bevel stop. DO NOT OVERTIGHTEN.
9. Verify that the blade is still aligned at 90° (0°).

BEVEL POINTER ADJUSTMENT (FIG. 18)

Once the blade has been set at a 90° (0°) angle to the table top, as described in section above, the angle pointer (1) may require adjustment.

If it does, follow these steps:

1. Loosen the pointer screw (2), and move the pointer until it is aligned with 90° (0°) on the bevel scale.
2. Retighten the pointer screw.

45° BEVEL STOP (FIG. 19)

1. Raise the blade to the maximum height by turning the control handle counter- clockwise.
2. Loosen the bevel angle locking knob.
3. Tilt the blade to the 45° bevel.
4. Using a square (1), verify that the blade is at a 45° angle to the table top.

Fig. 17

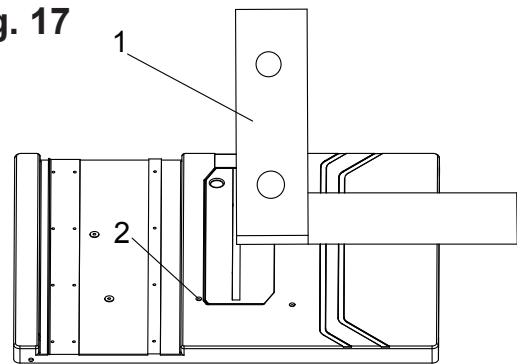

Fig. 18

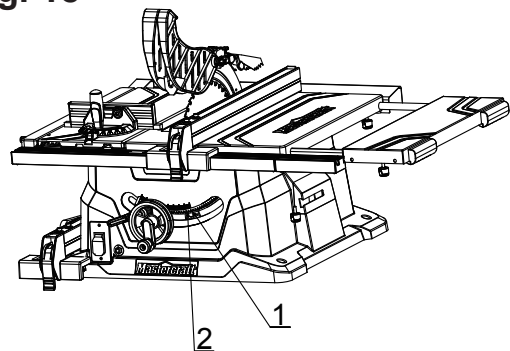
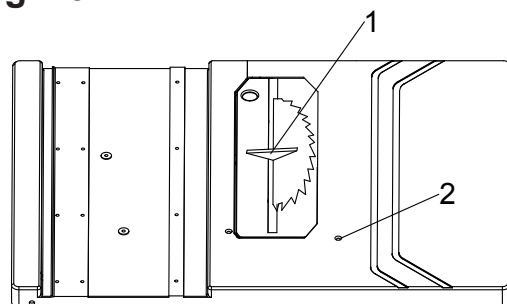

Fig. 19



V. Assembly and adjustments(continued)

5. If blade is not at a 45° angle to the table, back off the adjustment screw (2).
6. Loosen the bevel locking knob and set the blade at a 45° angle to the table.
7. Once the blade is at a 45° angle to the table top, tighten the bevel angle locking knob
8. Carefully tighten the adjusting screw (2) until it touches the bevel stop. DO NOT OVERTIGHTEN.
9. Verify that the blade is still aligned at 45°.

ADJUSTING THE LASER GUIDE (FIG. 20)

WARNING: The laser beam is emitted when the laser guide is turned on. Do not stare into beam or look directly at it using optical instruments. Do not remove the warning label that is affixed to the blade guard. Do not direct the laser into the eyes. strongly recommend the use of laser protective eyewear for the specific wavelength of emitted light when working on or near reflective surfaces.

NOTE: All of the adjustments for the operation of this machine have been carried out at the factory. Occasional readjustments may be necessary as a result of normal wear and use.

1. Turn the laser guide on. Place a straight edge or ruler against the right side of the blade.
2. Verify whether the laser line is flush against the right side of the blade, and against the straight edge or ruler.
3. If the laser line is not flush, loosen the two set screws (2) with a hex wrench, but do not remove them.
4. Using a hex wrench (not provided), adjust the laser unit (1) until the laser line is parallel with the blade.

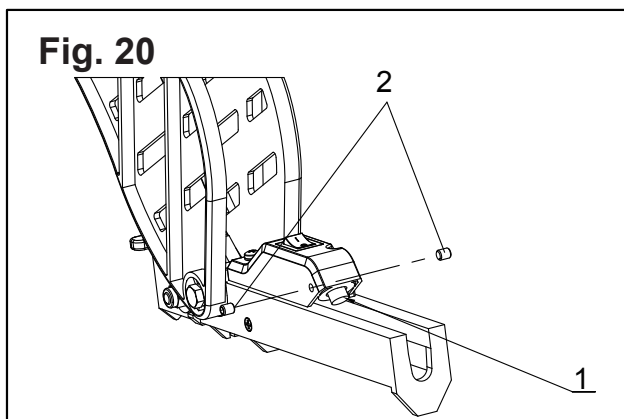

NOTE: Be careful not to over-rotate the laser unit. Do not rotate the laser more than 1/8 of a turn in either direction.

5. Adjust the set screw (2) on the left or right side in order to shift the laser line until it is flush with the right side of the blade. Once proper alignment has been achieved, tighten the set screw on the other side slowly, until it touches the laser, in order to lock the laser into position. Turn the laser guide off.

WARNING: DO NOT PLUG THE TABLE SAW INTO THE OUTLET UNTIL ALL INSTALLATIONS AND ADJUSTMENTS HAVE BEEN COMPLETED AND THE SAFETY AND OPERATIONAL INSTRUCTIONS IN THIS MANUAL HAVE BEEN READ CAREFULLY AND UNDERSTOOD FULLY.

V. Assembly and adjustments(continued)

UNFOLDING THE STAND (FIG. 21)

1. Release the knob (1)(2).
2. Lift the stand up, unfold the wider leg set (3) and unfold the narrower leg set (4).
3. Lock the locking knobs (1)(2).

NOTE: Verify that the stand is securely locked in position.

4. Attach the levelling pad (5) to the wider leg set (3) using the screw (6).

ASSEMBLING THE ROLLER WHEELS (FIG. 21)

Attach the roller wheels (7) to the roller wheel supports (12) using hex bolts (8) and nuts (9), as illustrated. Do not over tighten, because doing so will not allow the wheels to turn.

Leveling pad (5) the is installed at the four corners of stand by hex bolt. stand extension poles (10) is installed at the lateral of stand. align two tips of pull handle (11) to the holes in the stand bracket and tighten them.

Fig. 21

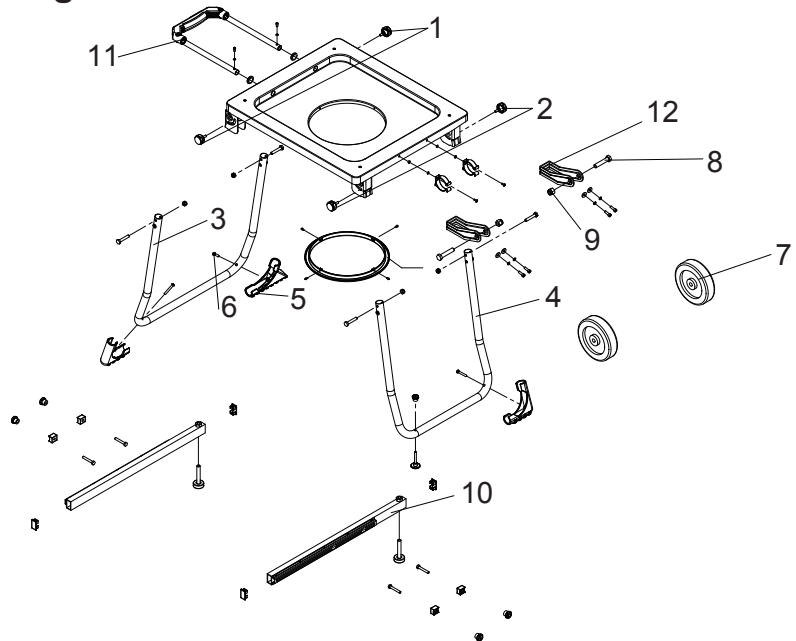

ATTACHING THE TABLE SAW TO THE STAND (FIG. 22)

1. Place the stand on a level surface, and adjust the right front adjustable stand pad (1) in order to level the stand to the floor.
2. Place the table saw on top of the stand (1), aligning the holes in the base with the holes in the stand.
3. Insert four hex bolts (2) through flat washers and through the holes in the base and the stand.
4. Tighten all four bolts. **NOTE:** Do not over tighten the bolts that hold the saw to the stand. Doing so may damage the saw base.

Fig. 22

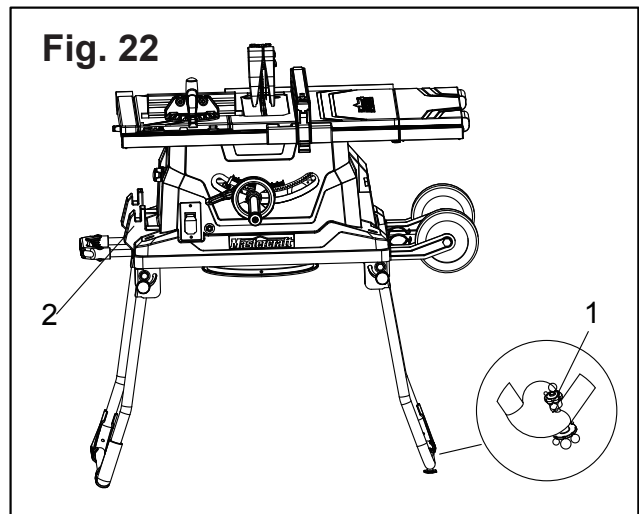

V. Assembly and adjustments(continued)

FOLDING THE TABLE SAW/STAND (FIG. 23)

1. Rotate the stand locking hook to the left. Lift up the two right-side stand locking levers in order to unlock, and lift the right side of the table saw up slightly off the floor (Fig. 23). Fold the leg set on the right side up to the base of the saw until it snaps into position with the spring clip (Fig. 23).
2. Slide the table extension toward the table until it rests against the saw table (Fig. 23-1).
3. Rest the right side of the saw onto the floor, release the two left-side stand locking levers, and tilt the saw on its right side. Fold the left-side leg set up to the base (Fig. 23).
4. Secure the legs into position by rotating the stand locking hook to the right.

SETTING UP THE TABLE SAW/STAND (FIG. 23)

1. Rotate the stand locking lever to the left. Unfold the leg set, and lock the stand locking levers in position by sliding the levers down the slots of the mounting brackets and pushing down in order to lock it in position.
2. Rest the left side of the saw on the floor, lift up the right side of the stand, and unfold the narrower right-side leg set (Fig. 23).
3. Secure the right-side legs in position by locking the stand locking levers in position, as described in step 1

NOTE:

Verify that the table saw is securely locked in position, and that the adjustable stand pad has stabilized the table saw before operation.

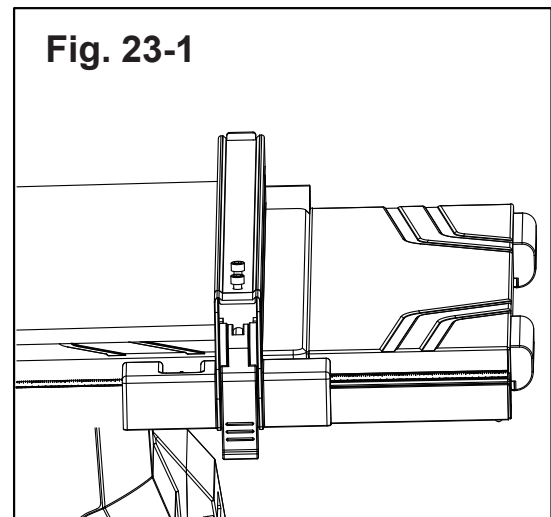
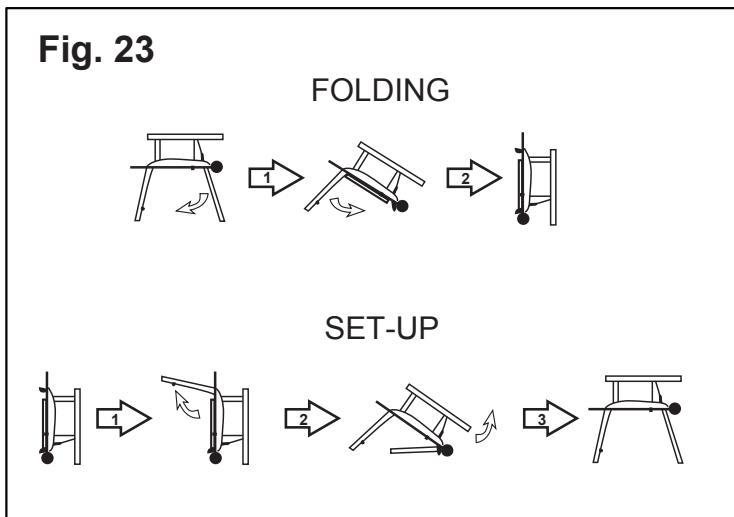

WARNING: Do not use this saw to cut metal. The hot chips or sparks may ignite sawdust or the material of the bag.

V. Assembly and adjustments(continued)

INSTALLING THE DUST BAG (FIG. 24)

1. Place the dust bag around the neck of the dust port. Tie the dust bag by pulling the drawstring tight, and secure it using the tie-clip.

MOUNTING THE TABLE SAW TO A WORKBENCH (FIG. 24-1)

1. If the stand will not be used, the table saw must be properly secured to a sturdy workbench using the four mounting holes on the base.
2. The workbench must have a hole that is large enough to allow for sawdust fall-through and removal.
3. Place the table saw in the centre of the workbench tabletop, and mark the location of the four 3/8" (9.5 mm) mounting holes (1) on the workbench tabletop.
4. Drill four 3/8" (9.5 mm) holes in the workbench tabletop.

NOTE: If there is not a hole that is large enough for sawdust removal and fall through,

proceed to step 5. If there is a hole that is large enough, proceed to step 7.

5. Mark a 11x11" (28x28 cm) square (2), centred between the four mounting holes (1).
6. Cut out and remove the square. This opening will allow sawdust to fall through the saw base.
7. Place the table saw on the workbench tabletop, and align the holes of the table saw with the holes that were drilled in the workbench tabletop. Fasten the table saw to the workbench using bolts and nuts.

IMPORTANT: When mounting the saw to the stand or workbench DO NOT over tighten the mounting bolts.

NOTE: If the stand or the workbench tends to move while the table saw is in use, the stand or workbench must be fastened to the floor.

WARNING: FAILURE TO PROVIDE THE SAWDUST FALL-THROUGH AND REMOVAL HOLE WILL CAUSE SAWDUST TO BUILD UP IN THE MOTOR AREA, WHICH MAY RESULT IN A FIRE HAZARD OR CAUSE DAMAGE TO THE MOTOR.

Fig. 24

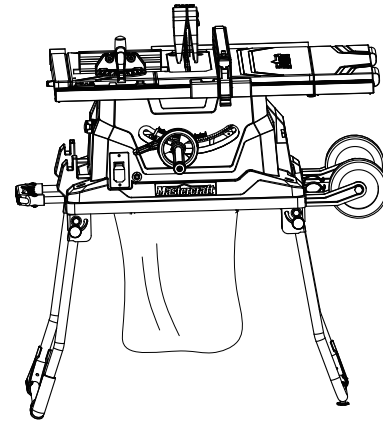
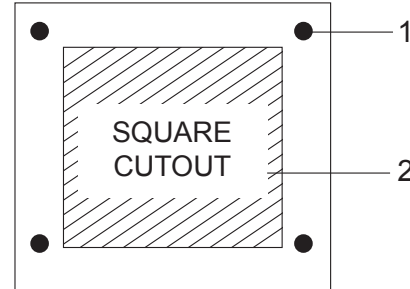

Fig. 24-1



V. Assembly and adjustments(continued)

LIMITED HOOKS AND GUARD PATHHOOKS (Fig. A)

1. Align the holes in the limited hooks (1) and the body of table saw.
2. insert head screw through flat washer and the holes in limited hooks.
3. Tighten the screws with cross screwdriver.
4. About guard pathhooks(2),pls follow the same assemble procedure of limited hooks.

Fig. A

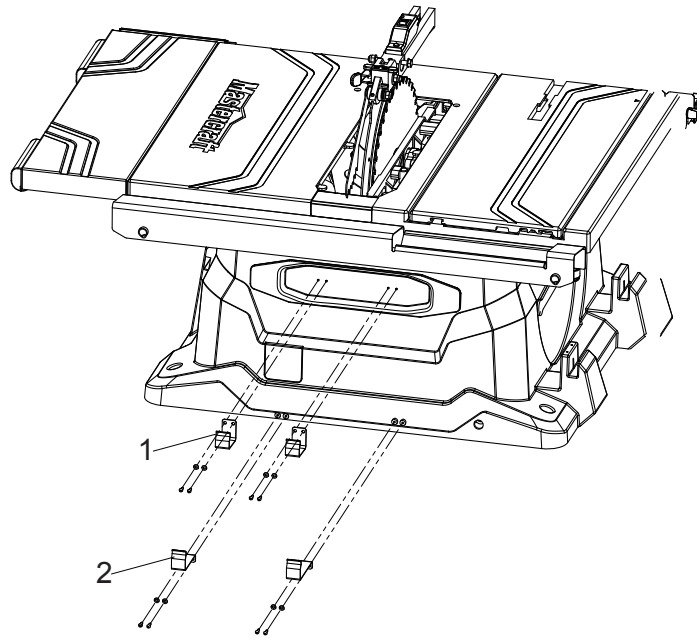

VI. Operating instructions

RAISING THE BLADE (FIG. 24-2)

Turn the blade raising control handle (1) COUNTER-CLOCKWISE in order to raise the blade.

NOTE: It is not necessary to loosen the blade tilting locking knob (2) when raising or lowering the saw blade.

TILTING THE BLADE (FIG. 24-2)

1. Loosen the blade bevel locking knob (2).
2. Slide the entire control handle assembly (1) to the desired location.
3. Tighten the blade bevel locking knob (2). Verify that the locking knob is fully tightened before attempting a cut.

ON/OFF PADDLE SWITCH (FIG. 24-3)

The ON/OFF paddle switch has a removable safety key. The saw cannot be turned on when the key is removed from the switch, which minimizes unauthorized use.

1. To turn the saw ON, insert the safety key (2) into the slot that is located above the switch, and then move the paddle switch (3) up to the ON position.
2. To turn the saw OFF, move the paddle switch (3) down. (Fig. 24-3)
3. To lock the saw in the OFF position, grasp the end of the safety key and pull it out.
4. The ON/OFF switch will not operate with the safety key removed.
5. If the safety key is removed while the saw is running, the saw can be turned OFF, but it cannot be restarted until the safety key (2) is reinserted.

OVERLOAD PROTECTION (FIG. 24-3)

This saw is equipped with a reset overload relay button (1) that will restart the motor after it shuts off due to overloading or low voltage. If the motor stops during operation, move the ON/OFF switch to the OFF position. Wait approximately five minutes for the motor to cool down, and then push the reset button (1) and move the switch to the ON position.

WARNING: IN ORDER TO AVOID INJURY AND PREVENT ACCIDENTAL START-UP WHEN THE RESET BUTTON IS PUSHED, THE ON/OFF PADDLE SWITCH SHOULD BE IN THE OFF POSITION, AND THE POWER CORD SHOULD BE UNPLUGGED FROM THE OUTLET WHILE THE SAW IS COOLING DOWN. OVERHEATING MAY BE CAUSED BY AN UNDER-SIZED EXTENSION CORD, AN EXTENSION CORD THAT IS TOO LONG, MISALIGNED PARTS, OR A DULL BLADE. INSPECT THE SAW FOR PROPER SET-UP BEFORE USING IT AGAIN.

Fig. 24-2

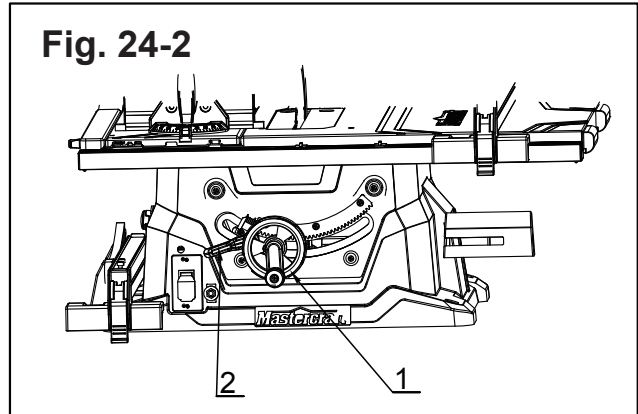
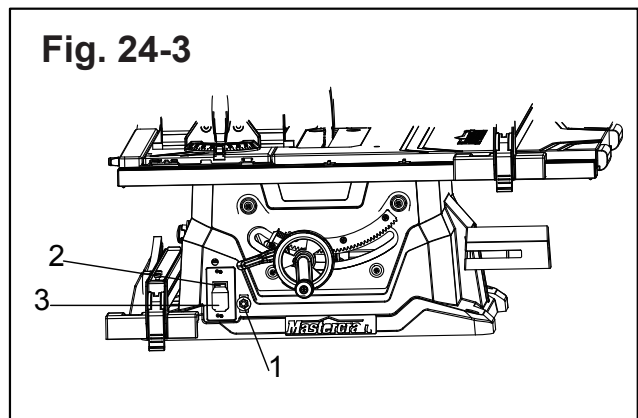

Fig. 24-3



VI. Operating instructions (continued)

USING THE TABLE EXTENSION WING (FIG. 25)

1. Unlock the table extension wing levers (2) on the two extension tube brackets.
2. Slide the extension tubes in or out until the scale on the front tube is positioned at the desired distance. Lock the table extension wing levers (2).
3. To adjust the position of the fence, loosen the locking handles (2), and place the auxiliary fence (1) in position.
4. Tighten the locking handles (2).

Fig. 25

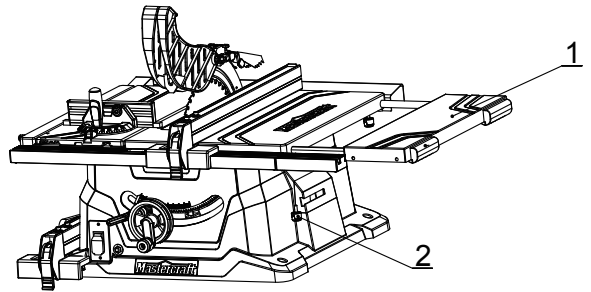

WARNING:FOR SAFETY REASONS, VERIFY THAT THE OPERATOR HAS READ THE SECTION ENTITLED GENERAL SAFETY GUIDELINES FOR THE TABLE SAW BEFORE OPERATING THIS SAW. VERIFY THE FOLLOWING BEFORE EVERY TIME THE TABLE SAW IS USED:

1. THE BLADE IS TIGHT.
2. THE BEVEL ANGLE LOCKING HANDLE IS LOCKED.
3. IF RIPPING, THE RIP FENCE LOCKING KNOB IS TIGHT, AND THE FENCE IS PARALLEL TO THE MITRE GAUGE GROOVE AND THE BLADE.
4. IF CROSSCUTTING, THE MITRE GAUGE KNOB IS TIGHT.
5. THE BLADE GUARD AND SPLITTER ARE IN PLACE, AND ARE WORKING PROPERLY.
6. SAFETY GLASSES ARE WORN.
7. FAILURE TO ADHERE TO THESE SAFETY RULES WILL GREATLY INCREASE THE CHANCES OF INJURY.

Before using the table saw, polish the tabletop with an automotive polishing wax in order to keep it clean, and to make it easier to slide the workpiece.

There are two basic types of table saw cuts: ripping and crosscutting. Ripping refers to cutting along the length of the grain and the workpiece. Crosscutting refers to either cutting across the width or across the grain of the workpiece. This distinction may be hard to make with man made materials. Therefore, cutting a piece of material to a different width is ripping, and cutting across the short dimension is crosscutting. Neither operation can be performed safely freehand: ripping requires the use of the rip fence, and crosscutting requires the use of the mitre gauge. Never use the rip fence and the mitre gauge at the same time during the cutting operation.

WARNING:Do not use more than one rip fence or a combination of a mitre gauge and a rip fence at the same time during a cutting operation.

VI. Operating instructions (continued)

RIPPING (FIG. 26, 26-1)

1. Remove the mitre gauge, and secure the rip fence to the table.
2. Raise the blade until it is approximately 1/8" (3.2 mm) above the top of the workpiece.
3. Place the workpiece flat on the table and against the fence so that the larger portion of the workpiece is between the blade and the fence. Keep the workpiece approximately 1" (2.5 cm) away from the blade.
4. Turn the saw ON, and wait for the blade to reach full speed.
5. Slowly feed the workpiece into the blade by pushing forward on the section of the workpiece that will pass between the blade and the fence (Fig. 26). the pattern that is provided in this manual. (Fig. 26-1)

Fig. 26

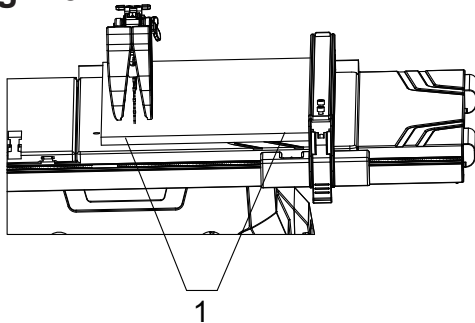
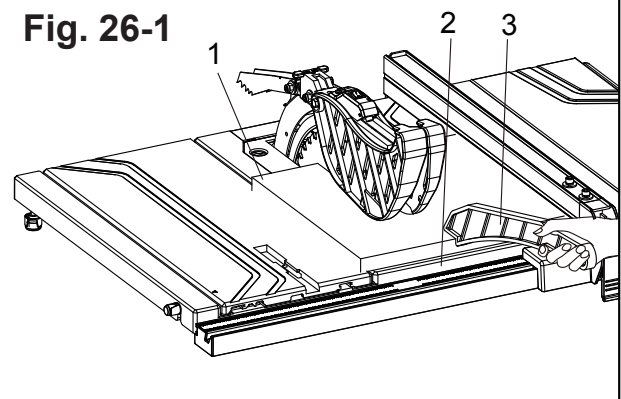

Fig. 26-1



CAUTION! To prevent serious injury:

- Do not allow frequent use of the table saw to cause complacency and careless mistakes. Remember that it only takes a fraction of a second of carelessness to cause a severe injury.
- Keep both hands away from the blade and the path of the blade.
- The workpiece must have a straight edge against the fence, and must not be warped, twisted, or bowed.

6. Do not place your thumbs on the table top. Always hold the workpiece (1) while the blade is turning. Do not let go of it in order to reach for the push stick. When both thumbs touch the front edge of the table (2), complete the cut using a push stick (3). Make a push stick using
7. Always use the push stick when performing ripping operations.
8. Continue to push the workpiece with the push stick until it passes the blade guard and clears the rear of the table.
9. Do not pull the workpiece backward while the blade is turning. Turn the switch OFF, and unplug the power cord. When the blade comes to a complete stop, raise the anti-kickback pawls on each side of the splitter, if necessary, and slide the workpiece out.

VI. Operating instructions (continued)

WARNING:

- DO NOT ATTEMPT TO PULL THE WORKPIECE BACKWARD WHILE THE BLADE IS TURNING. TURN THE SWITCH OFF, AND WAIT UNTIL THE BLADE HAS COME TO A COMPLETE STOP BEFORE CAREFULLY SLIDING THE WORKPIECE OUT.
- DO NOT PERFORM ANY OPERATION FREEHAND.
- AVOID KICKBACK BY KEEPING BLADES SHARP, VERIFYING THAT THE RIP FENCE IS PARALLEL TO THE SAW BLADE, AND KEEPING THE SPLITTER, ANTI-KICKBACK PAWLS, AND GUARDS IN PLACE, IN ALIGNMENT, AND FUNCTIONING PROPERLY.

BEVEL RIPPING

Bevel ripping is the same as ripping, except that the blade bevel angle is set to an angle other than "0".

CAUTION!THE WORKPIECE AND THE FENCE MUST BE ON THE RIGHT SIDE OF THE BLADE WHEN CUTTING.

RIPPING SMALL PIECES

CAUTION!AVOID INJURY CAUSED BY CONTACT WITH THE BLADE. DO NOT USE THIS SAW TO MAKE THROUGH-CUTS THAT ARE NARROWER THAN 1/2" (13 MM).

1. It is not safe to rip small pieces. Instead, rip a larger piece in order to obtain the size of the desired piece.
2. When ripping a small workpiece, it is not safe to place the hand between the blade and the rip fence. Use one or more push sticks to push the workpiece completely past the blade. (Fig. 26-1)

VI. Operating instructions (continued)

CROSSCUTTING (FIG. 27)

CAUTION! To prevent serious injury:

- Do not allow familiarity with or frequent use of the table saw to cause careless mistakes. Remember that even a fraction of a second of carelessness is enough to cause a severe injury.
- Keep both hands away from the blade and the path of the blade.
- Do not attempt to pull the workpiece backward during a cutting operation. This will cause kickback, and may result in serious injury to the operator.

1. Remove the rip fence, place the mitre gauge in the mitre gauge groove on the table, and release the sliding mitre blade locking lever (4).
2. Raise the blade until it is approximately 1/8" (3.2 mm) above the top of the workpiece.
3. Hold the workpiece firmly against the mitre gauge, with the path of the blade in line with the desired cutting line. Move the workpiece to within 1" (2.5 cm) of the blade.
4. Start the saw, and wait for the blade (1) to reach full speed. Do not stand directly in line with path of the saw blade. Instead, stand to the side of the blade, on the side where the cut is being made.
5. Keep the workpiece (2) against the face of the mitre gauge (3) and flat against the table. Slowly push the workpiece through the blade.
6. Do not attempt to pull the workpiece backward while the blade is turning. Turn the switch OFF, and wait until the blade has come to a complete stop before carefully sliding the workpiece out.

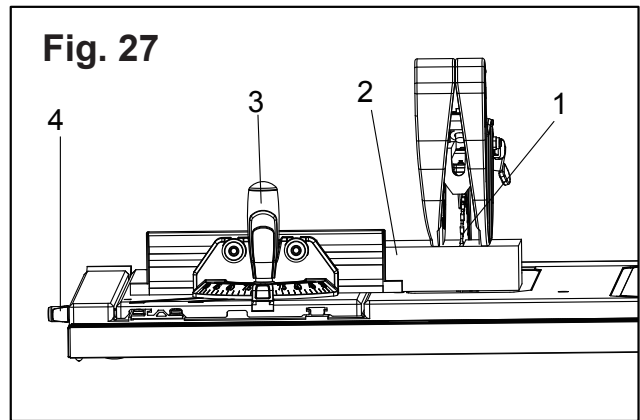

WARNING: In order to avoid instability, always place the larger surface of the workpiece on the table when crosscutting and/or bevel crosscutting.

VI. Operating instructions (continued)

BEVEL CROSSCUTTING (FIG. 28) 0° - 45° BLADE BEVEL & 90° MITRE ANGLE

This operation is the same as crosscutting, except that the blade is at a bevel angle other than 0°.

1. Adjust the blade (1) to the desired angle, and then tighten the blade bevel locking knob.
2. Tighten the mitre locking handle (3) at 90°.
3. Hold the workpiece (2) firmly against the face of the mitre gauge throughout the cutting operation.

Fig. 28

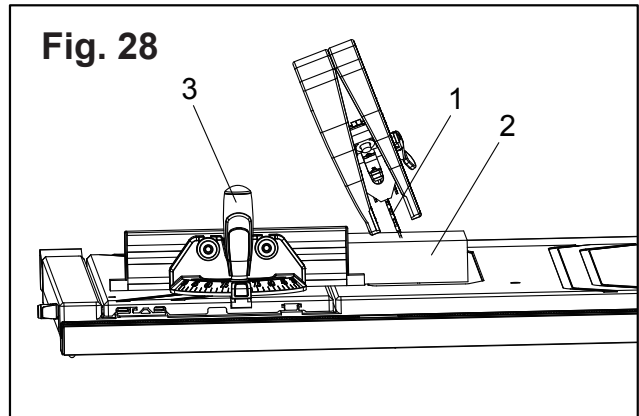

COMPOUND MITRE CROSSCUTTING (FIG. 29) 0° - 45° BLADE BEVEL & 0° - 45° MITRE ANGLE

This sawing operation combines a mitre angle with a bevel angle.

1. Set the mitre gauge (3) to the desired angle.
2. Set the blade (1) bevel to the desired bevel angle, and tighten the blade bevel locking knob.
3. Hold the workpiece (2) firmly against the face of the mitre gauge throughout the cutting operation.

Fig. 29

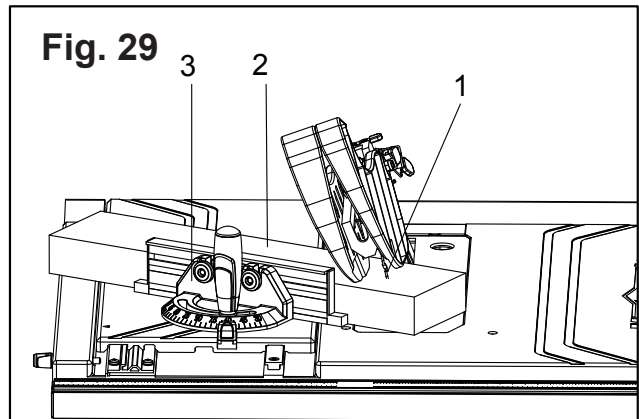

MITERING: 0° - 45° MITRE ANGLE (FIG. 30)

This operation is the same as crosscutting, except that the mitre gauge is locked at an angle other than 90°.

1. Set the blade (1) to a 0° bevel angle, and tighten the blade bevel locking knob.
2. Set the mitre gauge (3) to the desired mitre angle, and secure it in position by tightening the mitre gauge locking handle.
3. Hold the workpiece (2) firmly against the face of the mitre gauge throughout the cutting operation.

Fig. 30

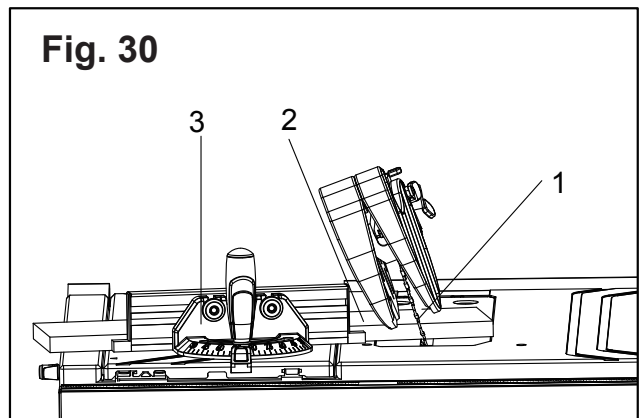

VI. Operating instructions (continued)

USING A WOOD FACING ON THE RIP FENCE (FIG. 31)

When performing certain cutting operations, it is necessary to add a wood facing to either side of the rip fence (2).

1. Use a smooth, straight, 3/4" (19 mm) thick wooden board (1) that is as long as the rip fence.
2. Attach the wood facing to the fence using wood screws (3). A wood facing should be used when ripping material such as thin paneling, in order to prevent the material from catching between the bottom of the fence and the table.

Fig. 31

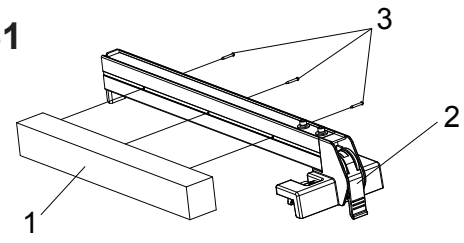

DADO CUTTING (FIG. 32)

CAUTION! Be very careful when the dado blade is running. There is no guard to protect the operator. Do not use adjustable or wobbling dado blades with this saw.

1. Unplug the power cord before removing and/or installing dado blades.
2. When making dado cuts, a dado insert plate must be installed in place of the regular table insert.
3. Instructions for operating the dado are packed with the dado set. (Purchased separately)
4. The arbor (1) of this saw restricts the maximum width of a dado cut to 1/2" (1.3 cm) (Fig. 32). The flange (2) must be installed prior to reinstalling and tightening the arbor nut (3).
5. **NOTE:** Verify that the arbor nut is tight and that at least one thread of the arbor sticks out past the nut.
6. After loosening the knob (5), press the device (4), the splitter (6) should be at the lowest position, the purpose is not intended to cut through the workpiece the splitter is on the middle position, the purpose is for non-through operations. Use only a stackable dado set, and keep the width to 1/2" (1.3 cm) or less. It will be necessary to remove the blade guard and kickback pawl when using the dado.
7. Use the correct number of round outside blades and chippers, as shown in the instruction manual for the dado set. The total width of the blades and chippers must be as follows: less than 1/2" (1.25 cm) and less than 8" (20.32 cm) in diameter.
8. Before starting the table saw, check to make sure the installed dado assembly will not strike the motor, table, or table saw base when in operation.

Fig. 32

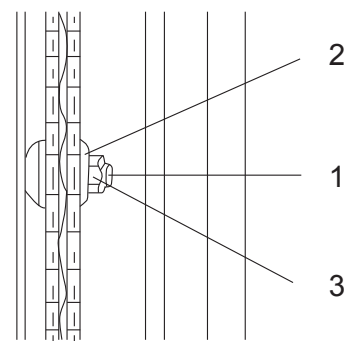
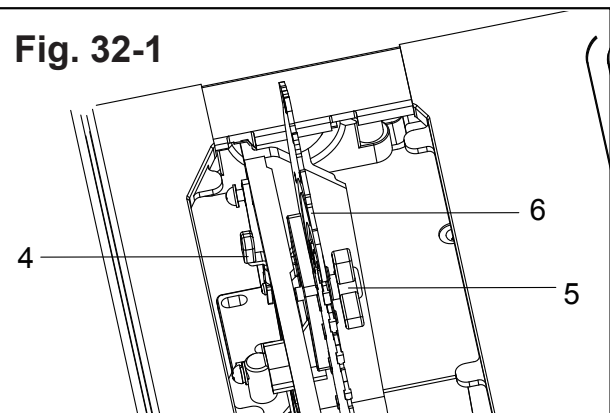

Fig. 32-1



VII. Maintenance

CAUTION! In order to avoid injury, always replace the blade, the blade guard assembly, and the table insert when once the dado cutting operation has been completed.

CAUTION: For safety reasons, turn the power switch OFF, remove the safety key, and unplug the saw from the outlet before performing any maintenance or lubrication.

DADO CUTTING

- Use a vacuum to clean out all sawdust that has accumulated inside the saw base and around the motor on a regular basis.
- Use an automotive wax to polish the saw table in order to keep it clean, and to make it easier to slide the workpiece.
- Clean the cutting blades using pitch and gum remover.
- Replace a worn, cut, or damaged power cord immediately.

CAUTION: Electrical and mechanical repairs must be performed by a qualified repair technician. Call the Tool-Free Helpline, at 1-800-689-9928. Use only identical replacement parts. Using substitute parts may create a hazard.

Use liquid dishwashing detergent and water to clean all plastic parts. **NOTE:** the use of certain cleaning chemicals may damage plastic parts.

Do not use the following cleaning chemicals or solvents on the table saw: gasoline, carbon tetrachloride, chlorinated solvents, ammonia, or household detergents that contain ammonia.

BLADE RAISING AND TILTING MECHANISM

The blade raising and tilting mechanisms should be checked for looseness, binding, or other abnormalities after every five hours of operation. Unplug the table saw from the outlet, and turn it upside down. Alternately pull up and down on the motor unit. Observe any movement in the motor mounting mechanism. (Fig. 33)

1. Turn the screw pole(1) in the fixed part(2) connection with the wheel.
2. The power will be transferred by the taper gear(3) and screw pole(4).
3. The pole (6) in the fixed part(5) will be moved up and down.

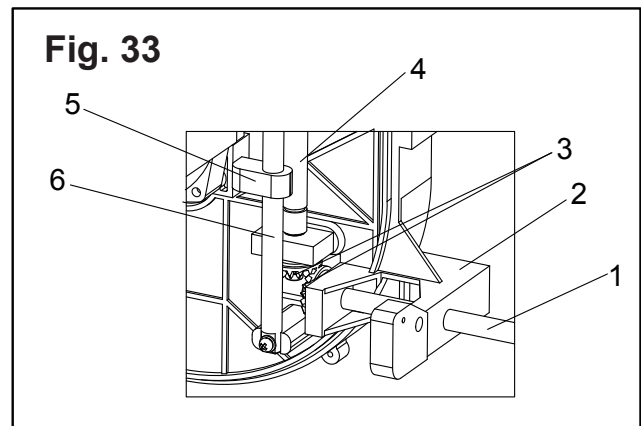

LUBRICATION

All motor bearings are permanently lubricated at the factory, and do not require any additional lubrication. Use graphite or silicone to lubricate all mechanical parts of the table saw where a pivot or threaded rod is present. Dry lubricants do not hold sawdust like oil or grease.

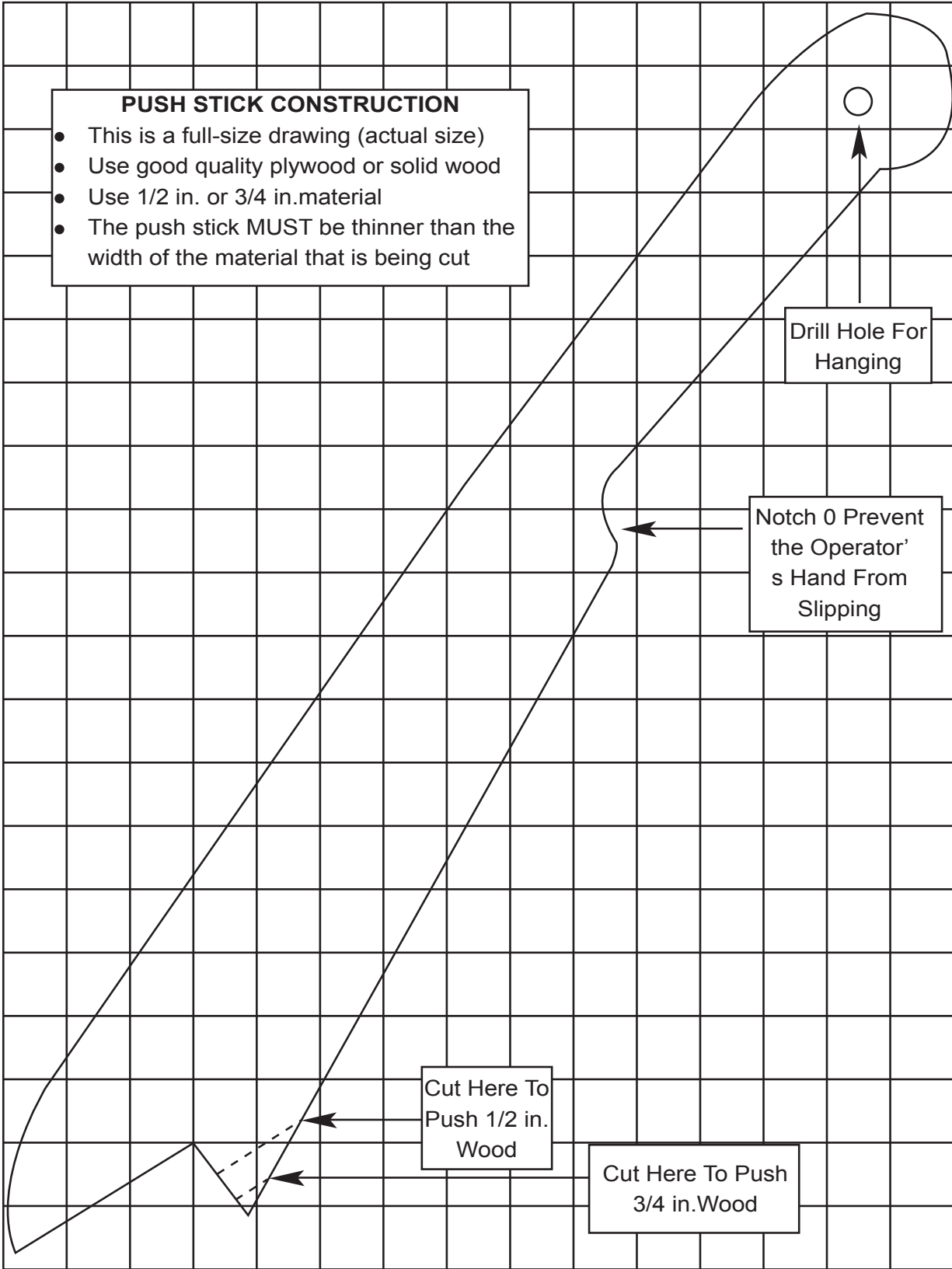

PUSH STICK CONSTRUCTION

- This is a full-size drawing (actual size)
- Use good quality plywood or solid wood
- Use 1/2 in. or 3/4 in. material
- The push stick **MUST** be thinner than the width of the material that is being cut

Drill Hole For Hanging

Notch To Prevent the Operator's Hand From Slipping

Cut Here To Push 1/2 in. Wood

Cut Here To Push 3/4 in. Wood

VIII. Troubleshooting guide

WARNING: In order to avoid injury from an accidental start-up, always turn the switch to the OFF position and unplug the table saw before moving the table saw or the blade, replacing the blade, or making adjustments to the table saw or the blade.

SYMPTOM	POSSIBLE CAUSES	CORRECTIVE ACTION
The saw will not start	<ol style="list-style-type: none"> 1. The saw is not plugged in. 2. The fuse has blown or the circuit breaker has tripped. 3. The cord is damaged. 	<ol style="list-style-type: none"> 1. Plug in the table saw. 2. Replace the fuse or reset the circuit breaker. 3. Have the cord replaced by a qualified electrician.
The saw does not make accurate 45° or 90° rip cuts	<ol style="list-style-type: none"> 1. The positive stop is not adjusted correctly. 2. The blade tilt pointer is not set correctly. 3. The rip fence is not properly aligned. 	<ol style="list-style-type: none"> 1. Check the blade with the square, and adjust the positive stop. 2. Check the blade with the square, and adjust the positive to zero. 3. Align the rip fence with the mitre gauge slot.
The material pinches the blade when ripping	<ol style="list-style-type: none"> 1. The rip fence is not aligned with the blade. 2. The wood is warped, or the edge that is against the fence is not straight. 	<ol style="list-style-type: none"> 1. Check and adjust the rip fence. 2. Select another piece of wood
The material binds on the splitter	<ol style="list-style-type: none"> 1. The splitter is not aligned correctly with the blade. 	<ol style="list-style-type: none"> 1. Check and align the splitter with the blade.
The saw makes unsatisfactory cuts	<ol style="list-style-type: none"> 1. The blade is dull. 2. The blade is mounted backwards. 3. There is gum or pitch on the blade. 4. The blade is not appropriate for the work that is being done. 5. There is gum or pitch on the table, causing erratic feeding. 	<ol style="list-style-type: none"> 1. Replace the blade. 2. Turn the blade around. 3. Remove the blade, and clean it with turpentine and coarse steel wool. 4. Change the blade. 5. Clean the table with turpentine and coarse steel wool, and apply a coat of automotive polishing wax.
The material kicks back from the blade	<ol style="list-style-type: none"> 1. The rip fence is out of alignment. 2. The splitter is not aligned correctly with the blade. 3. The workpiece is being fed without the rip fence. 4. The splitter is not in place. 5. The blade is dull. 6. The operator is letting go of the material before it has passed the saw blade. 7. The mitre angle locking knob is loose. 	<ol style="list-style-type: none"> 1. Align the rip fence with the mitre gauge slot. 2. Align the splitter with the blade. 3. Install and use the rip fence. 4. Install and use the splitter (with the guard). 5. Replace the blade. 6. Push the material all the way past the saw blade before releasing the workpiece. 7. Tighten the knob.
The blade does not raise or tilt freely	<ol style="list-style-type: none"> 1. There is sawdust and/or dirt in the raising and tilting mechanisms. 	<ol style="list-style-type: none"> 1. Brush or blow out any loose dust and dirt.
The blade does not reach full speed	<ol style="list-style-type: none"> 1. The extension cord is too light or too long. 2. The voltage from the outlet is too low. 	<ol style="list-style-type: none"> 1. Replace with the proper size of extension cord. 2. Contact the electricity supplier.
The saw vibrates excessively	<ol style="list-style-type: none"> 1. The saw is not mounted securely to the workbench. 2. The stand is on an uneven surface. 3. The blade is damaged. 	<ol style="list-style-type: none"> 1. Tighten all mounting hardware. 2. Reposition the table saw on a flat level surface. 3. Replace the blade.

IX. Warranty

This Mastercraft product carries a one (3) year repair warranty against defects in workmanship and materials. At its discretion, Mastercraft Canada agrees to have any defective part(s) repaired or replaced free of charge, within the stated warranty period, when returned by the original purchaser with proof of purchase. This product is not guaranteed against wear or breakage due to misuse and/or abuse.

This product is not guaranteed if used for commercial or industrial purposes.

X. Parts list

MASTERCRAFT TABLE SAW WITH SLIDING TABLE

When servicing this Mastercraft table saw, use only Mastercraft replacement parts. The use of any other parts may cause damage to the product. All servicing should be performed by a qualified service technician. To find the nearest technician, call the toll- free helpline, at 1-800-689-9928.

WARNING: ANY ATTEMPT TO REPAIR OR REPLACE ELECTRICAL PARTS ON THIS TABLE SAW MAY CREATE A HAZARD UNLESS THE REPAIRS ARE CARRIED OUT BY A QUALIFIED SERVICE TECHNICIAN.

No	Description	Qty	No	Description	Qty
1	Screw	1	34	Hex bolt M4×12	2
2	Locking ring	2	35	Guide (A)	1
3	Compaction shaft	1	36	Guide (B)	1
4	Bolt M4×10	13	37	Table insert	1
5	Flat washer 4	18	38	Hex bolt M6×20	2
6	Eccentricity handle	1	39	Main table	1
7	Bolt M4×8	4	40	Washer board	1
8	Compaction washer	2	41	Rear extension pole	2
9	Rip fence fix seat	1	42	Limited ring	2
10	Pointer	1	43	Rear extension table	1
11	Hex bolt M6×20	4	44	Screw M6×58	1
12	Spring washer 6	19	45	Blade guard (left)	1
13	Big washer 6	13	46	Laser switch	1
14	Rip fence pipe	1	47	Bolt M4×16	1
15	Rub washer		48	Laser seat	1
16	Compress spring	1	49	Hex bolt M5×6	2
17	Press board	1	50	Laser	
18	Locking nut M6	4	51	Washer (C)	3
19	Mitre bar insert	2	52	Compaction ring (A)	2
20	Mitre guide knob cover	1	53	Bolt ST2.9×8	2
21	Mitre guide knob	1	54	Hex bolt M4×15	2
22	Flat washer 6	25	55	Bolt M4×10	2
23	Mitre guide locking knob	2	56	Guard support board	1
24	Mitre guide pointer	1	57	Support board ring	3
25	Bolt ST2.9×8	4	58	Gasket	1
26	Washer 3	2	59	Guard support seat	1
27	Rip fence	1	60	Connect shaft (A)	1
28	Mitre guide	1	61	Battery dust cover	1
29	Screw M6×25	2	62	Battery box	1
30	Bevel bar	1	63	Battery	2
31	Sliding table	1	64	Battery cover	1
32	Bolt M5×10	12	65	Blade guard (right)	1
33	Washer 5	14	66	Circumgyrate wrench	2

X. Parts list(continued)

No	Description	Qty	No	Description	Qty
67	Spring pin 4×12	2	109	Orientation shaft (A)	2
68	Uncork ring 9	2	110	Rip knife press board	1
69	Limited piece	2	111	Rip knife locking knob	1
70	Spring pin 4×30	1	112	Up-down guide column	2
71	Compaction ring (B)	2	113	Up-down adjustment screw (B)	1
72	Limited support seat	1	114	Flat key 4×8	2
73	Spring	1	115	Up-down adjustment seat	1
74	Connect shaft (B)	1	116	Taper gear	2
75	Out handle	2	117	Ring for shaft 10	2
76	Hex bolt M14	2	118	Fix seat (B)	1
77	Inside handle	2	119	Angle pointer	1
78	Bolt ST4.2×12	12	120	Spring washer 4	1
79	Scale seat board (B)	2	121	Up-down adjustment screw (A)	1
80	Scale seat (B)	1	122	Bolt M6×16	4
81	Bolt ST4.2×8	8	123	Fix seat (B)	2
82	Scale seat board (A)	2	124	Screw M6×16	2
83	Scale label (B)	1	125	Clearance piece	2
84	Square screw M6×16	5	126	Hex bolt M5×20	2
85	Nut M6	5	127	Sliding piece	2
86	Scale extension pole (right)	1	128	Hex bolt M6×12	1
87	Scale label (C)	1	129	Body	1
88	Extension table	1	130	Dust insert	1
89	Extension pole (right)	1	131	Inside plywood	1
90	Extension pole knob	4	132	Blade	1
91	Bolt M6×20	8	133	Outside plywood	1
92	Scale label (A)	1	134	Thin nut M16	1
93	Scale seat (A)	1	135	Bolt ST2.9×10	10
94	Orientation pin	1	136	Limited hook	2
95	Locking compress spring	1	137	Hook for cord	1
96	Orientation block	1	138	Big washer 4	4
97	Orientation pin knob	1	139	Plug & cord	1
98	Bolt M3×18	1	140	Press wire block	1
99	Uncork ring 3.5	1	141	Cord inlet	1
100	Locking nut M3	1	142	Bolt ST4.2×16	2
101	Adjustment pole	1	143	Guard pothook (A)	1
102	Motor parts	1	144	Guard pothook (B)	1
103	Rip knife base	1	145	Insert	1
104	Compress spring	1	146	Hex bolt M8×35	4
105	Rip knife orientation pin	1	147	Washer 8	4
106	Rip knife	1	148	Miter guide board	1
107	Bolt M5×20	4	149	Locking nut M5	3
108	Spring washer 5	10	150	Reinforce side board	1

X. Parts list(continued)

No	Description	Qty	No	Description	Qty
151	Rack (B)	1	195	Wheel bolt	2
152	Bolt M5×16	3	196	Nut M12	2
153	Overloading protection	1	197	Bag clamp	2
154	Junction box groupware	1	198	Stand board groupware	1
155	Switch box cover	1	199	Hex bolt M5×8	2
156	Rubber ring	2	200	Stand pipe	2
157	Custer brand	1	201	Bolt M5×30	2
158	Wire block	2	202	Handle	1
159	Overloading nut	1	203	Bolt M5×35	4
160	Switch	1	204	Front cover	1
161	Bolt M5×8	4	205	Inside ring	1
162	Bolt M4×12	2	206	Bearing 6201-2Z	1
163	Switch board	1	207	Rotor	1
164	Overloading label	1	208	Bolt ST4.8×70	2
165	Case	1	209	Stator	1
166	Screw M8×30	1	210	Bearing 6001-2Z	1
167	Locking ring	1	211	Damping ring	1
168	Blade wrench	2	212	Brush cap	2
169	Blade knob	1	213	Brush	2
170	Push sticker	1	214	Brush holding	2
171	Main label	1	215	Press wire board	1
172	Washer ring	1	216	Bolt M5×8	2
173	Locking compress spring	1	217	Cover board	1
174	Compaction screw	1	218	Body	1
175	Nut M5	6	219	Oilness bearing	1
176	Locking handle	1	220	Ring for shaft 16	1
177	Hex bolt M5×12	1	221	Gear	1
178	Circumgyrate wheel	1	222	Output shaft	1
179	Circumgyrate handle	1	223	Half-round key 5×6.5×16	1
180	Circumgyrate knob	1	224	Ring for hole/shaft 35	1
181	Handle bolt	1	225	Bearing 6003-2Z	1
182	Bolt M5×16	1	226	Gear cover	1
183	Feet (A)	2	227	Bolt M5×16	3
184	Adjustment feet	1	228	Pipe bush	2
185	Locking knob (B)	1	229	Wheel support	2
186	Bolt M6×40	3	230	Hex bolt M6×10	4
187	Stand (A)	1	231	Hex wrench 5	1
188	Wheel	2	232	Switch board	1
189	Screw M8×45	4	233	Support board	4
190	Nut M8	4	234	Extension pole (B)	1
191	Dust collection ring	1	235	Adjustment screw	2
192	Rubber feet (B)	1	236	Extension pole (A)	1
193	Stand (B)	1	237	Screw M6×50	4
194	Stand knob	4	238	Stand washer	4

X. Parts list(continued)

No	Description	Qty	No	Description	Qty
239	Dado insert	1	241	hex wrench 5	1
240	hex wrench 5	1	242	bolt	1

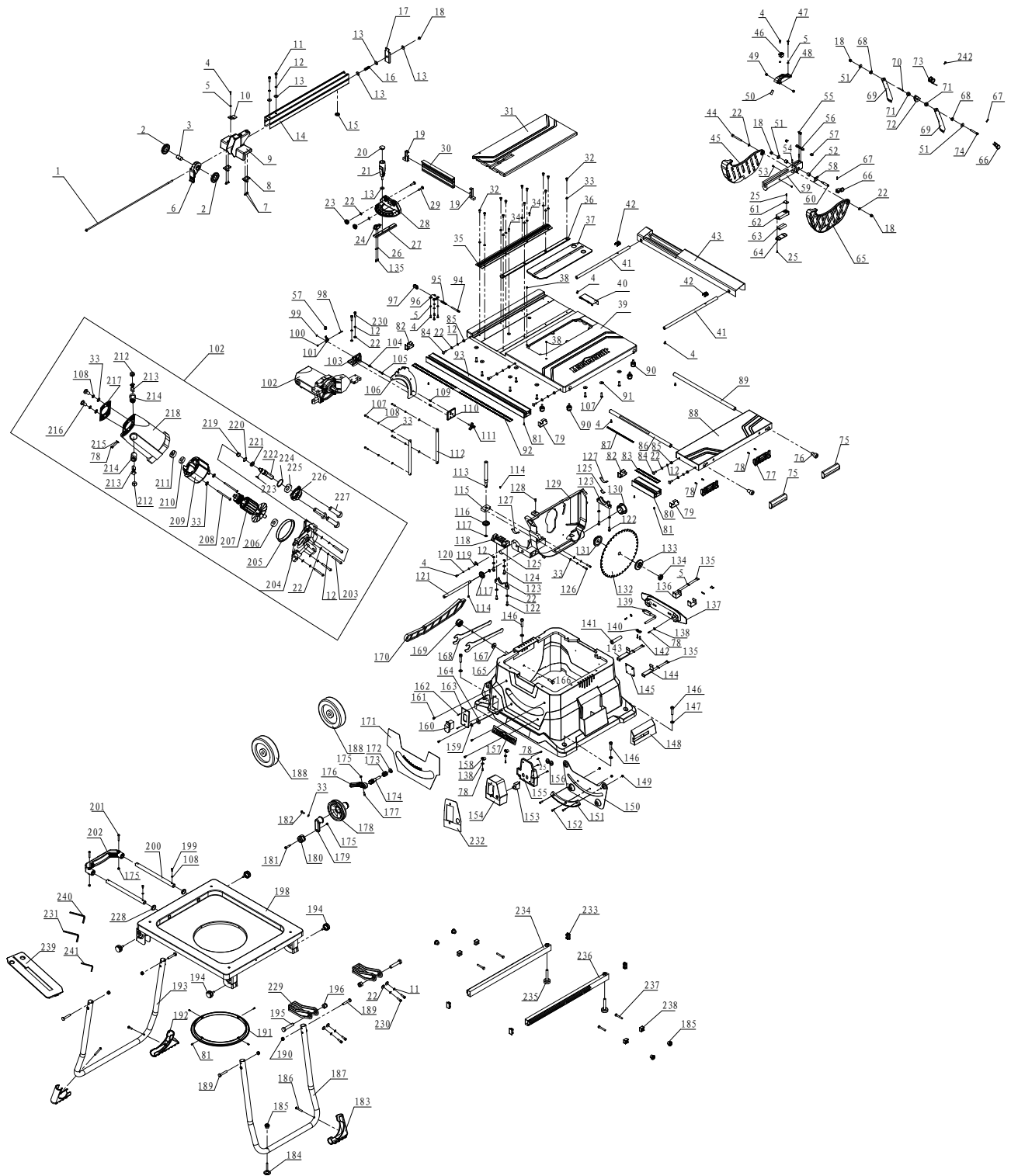

Imported by Mastercraft Canada Toronto, Canada M4S 2B8