

5 QUICK TIPS

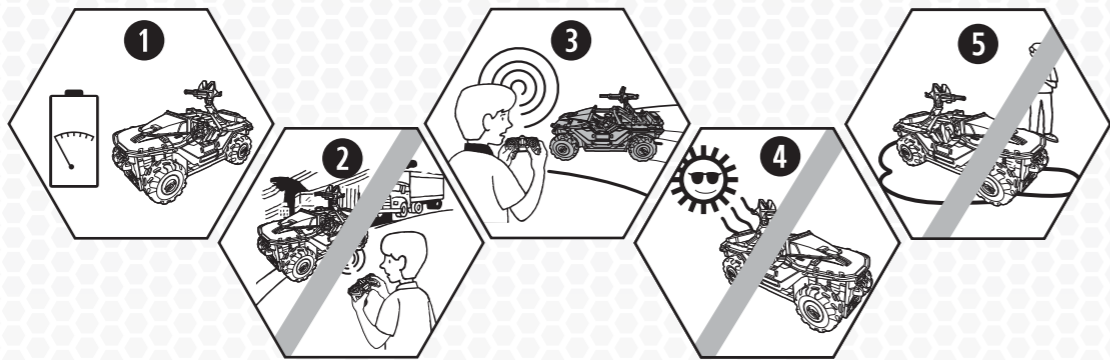

- When your vehicle starts to lose power, it may lose functionality or performance. It's time for fresh batteries. Your vehicle's running time may change depending on your driving style and driving environment.
- Radio interference can affect your vehicle's performance. Interference can be caused by other R/C vehicles running on the same frequency, electrical wires, large buildings or CB radios. Try to stay away from these!
- Point your transmitter up, not down toward your vehicle. If your vehicle gets too far away, it won't work properly.
- Don't store your vehicle near heat or in direct sunlight. Always turn switches OFF and remove all batteries for storage.
- Don't drive your vehicle in sand or through water or snow. Do not immerse in water. If your vehicle or transmitter does get wet, wipe it with a towel, remove batteries, and allow to dry completely overnight. Replace with fresh batteries before next use.
- When exposed to an electrostatic source, the product may malfunction. To resume normal operation, remove and re-install the batteries. This should reset your vehicle and let you resume normal operation.

6 CONSUMER INFORMATION

Note to Adults: To ensure that the child's play is both safe and fun, please review all operating instructions and safety rules with your child.

- NEVER drive your vehicle on streets! Streets are for real cars!
- DO NOT pick up the vehicle while it is in motion.
- Keep fingers, hair and loose clothing away from the wheels while the vehicle is switched ON.
- Adult supervision is recommended while this toy is being operated.
- When not in use, turn off the vehicle. To avoid accidental operation, remove all batteries.

BATTERY SAFETY INFORMATION

In exceptional circumstances batteries may leak fluids that can cause a chemical burn injury or ruin your product. To avoid battery leakage:

- Non-rechargeable batteries are not to be recharged.
- Rechargeable batteries are to be removed from the product before being charged.
- Rechargeable batteries are only to be charged under adult supervision.
- Do not mix alkaline, standard (carbon-zinc), or rechargeable (nickel-cadmium) batteries.
- Do not mix old and new batteries.
- Only batteries of the same or equivalent type as recommended are to be used.
- Batteries are to be inserted with the correct polarity.
- Exhausted batteries are to be removed from the product.
- The supply terminals are not to be short-circuited.
- Dispose of battery(ies) safely.
- Do not dispose of this product in a fire. The batteries inside may explode or leak.

Protect the environment by not disposing of this product with household waste (2012/19/EU). Check your local authority for recycling advice and facilities.

THIS DEVICE COMPLIES WITH PART 15 OF THE FCC RULES.

Operation is subject to the following two conditions: (1) This device may not cause harmful interference, and (2) this device must accept any interference received, including interference that may cause undesired operation.

This equipment has been tested and found to comply with the limits for a Class B digital device, pursuant to part 15 of the FCC rules. These limits are designed to provide reasonable protection against harmful interference in a residential installation. This equipment generates, uses and can radiate radio frequency energy and, if not installed and used in accordance with the instructions, may cause harmful interference to radio communications. However, there is no guarantee that interference will not occur in a particular installation. If this equipment does cause harmful interference to radio or television reception, which can be determined by turning the equipment off and on, the user is encouraged to try to correct the interference by one or more of the following measures:

- Reorient or relocate the receiving antenna.
- Increase the separation between the equipment and receiver.
- Connect the equipment into an outlet on a circuit different from that to which the receiver is connected.
- Consult the dealer or an experienced radio/TV technician for help.

NOTE: Changes or modifications not expressly approved by the manufacturer responsible for compliance could void the user's authority to operate the equipment.

4



INSTRUCTION SHEET SPECIFICATIONS	
Toy No.:	RC_Deluxe Warthog
Part No.:	DECCO
Item Size:	0970
Folded Size:	A4
Type of Fold:	
# colors:	Black
Paper Stock:	White Offset
Paper Weight:	70 lb.
EDM No.:	

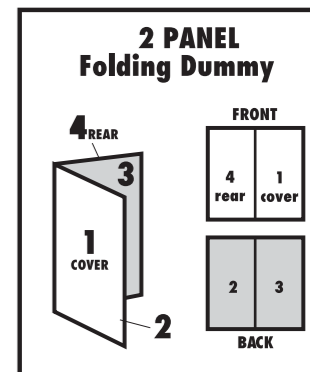

1 CONTENTS

CAUTION: To prevent entanglement, keep all hair away from the wheels.

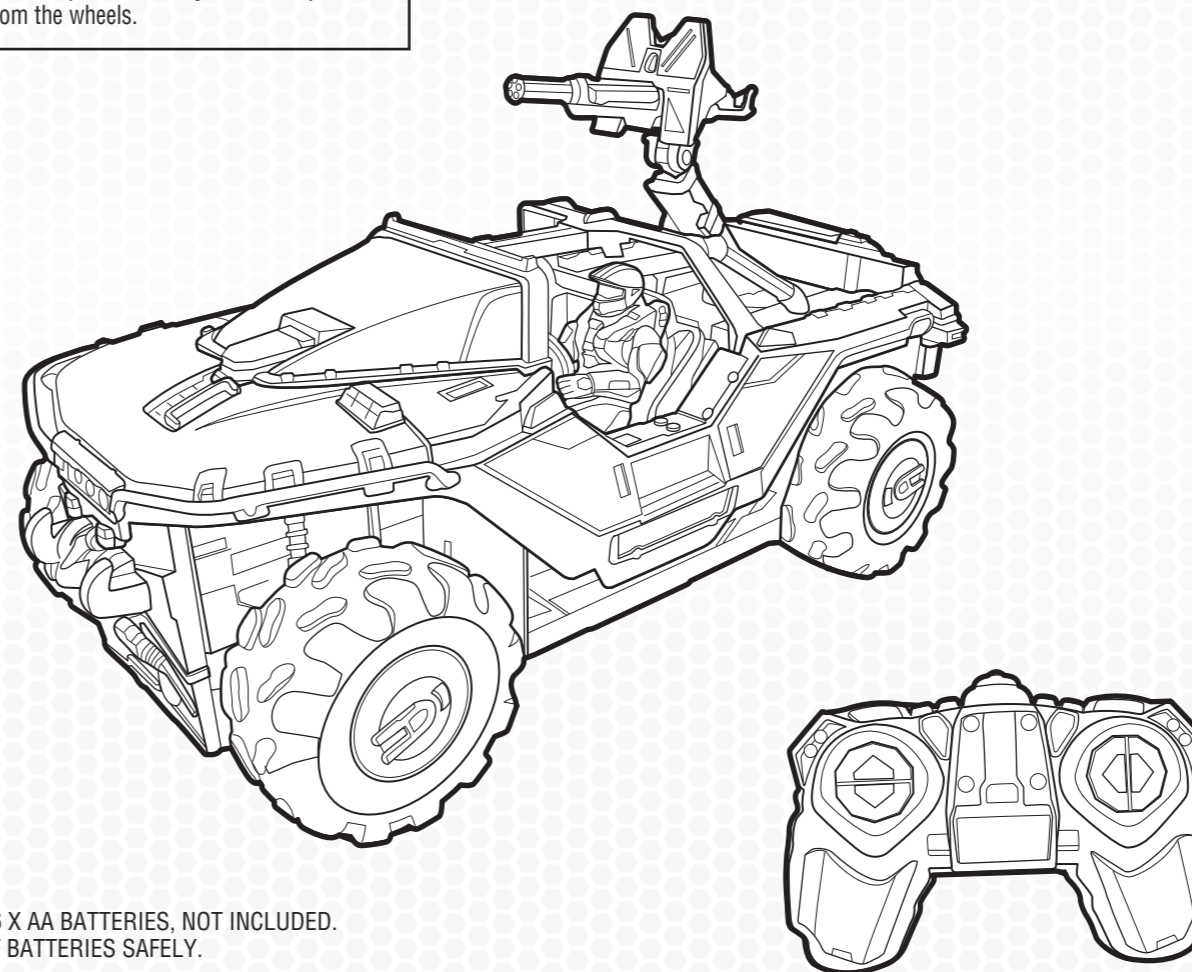

REQUIRES 6 X AA BATTERIES, NOT INCLUDED. DISPOSE OF BATTERIES SAFELY.

©2016 Mattel. All Rights Reserved. ® and ™ designate U.S. trademarks of Mattel, except as noted. Mattel, Inc., 636 Girard Avenue, East Aurora, NY 14052, U.S.A. Consumer Relations 1-800-524-8697. Mattel U.K. Ltd., Vanwall Business Park, Maidenhead SL6 4UB. Helpline 01628 500303. Mattel Australia Pty., Ltd., Richmond, Victoria. 3121. Consumer Advisory Service - 1300 135 312. Mattel East Asia Ltd., Room 503-09, North Tower, World Finance Centre, Harbour City, Tsimshatsui, HK, China. Diimport & Diedarkan Oleh: Mattel SEA Ptd Ltd.(993532-P) Lot 13.5, 13th Floor, Menara Lien Hoe, Persiaran Tropicana Golf Country Resort, 47410 PJ, Malaysia. Tel:03-78803817, Fax:03-78803867.

©2016 Microsoft Corporation. All Rights Reserved. Microsoft, 343 Industries, the 343 Industries logo, Halo, the Halo logo are trademarks of the Microsoft group of companies.

SERVICE.MATTEL.COM

Microsoft
Studios
343
INDUSTRIES

1

2 BATTERY INSTALLATION

Requires 4 AA (LR06) Alkaline batteries for the vehicle and 2 AA (LR06) Alkaline batteries for the transmitter. For longer life, use Alkaline batteries. Dispose of batteries safely.

VEHICLE

- Unscrew the battery cover with a Phillips head screwdriver (not included).
- Install 4 AA Alkaline batteries (not included) with polarity (+/-) as shown inside the battery compartment.
- Replace battery cover and tighten screw.

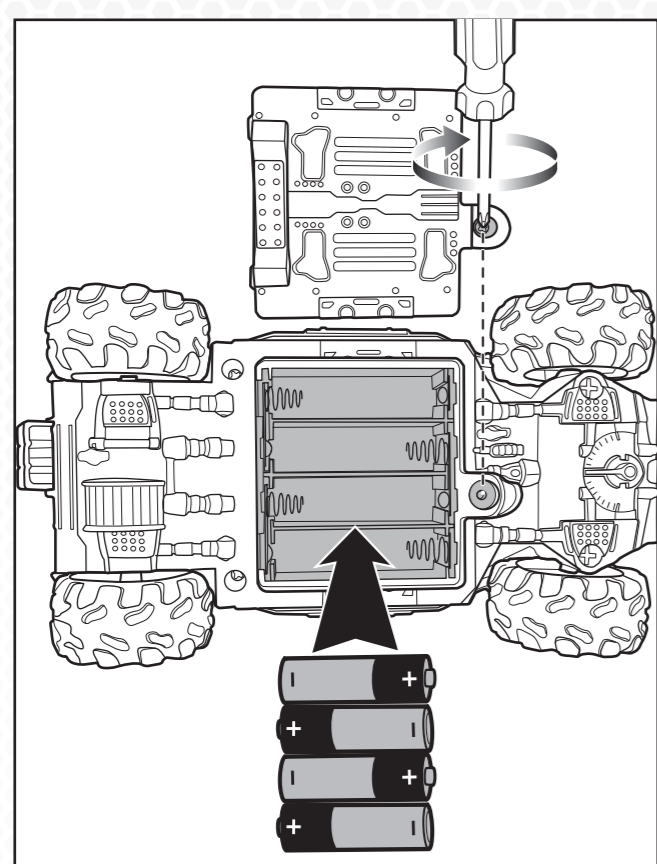

TRANSMITTER

- Unscrew the battery cover with a Phillips head screwdriver (not included).
- Install 2 AA Alkaline batteries (not included) with polarity (+/-) as shown inside the battery compartment.
- Replace battery cover and tighten screw.

NOTE: Once batteries are installed, the transmitter will always be "ON" and will work the moment you use it.

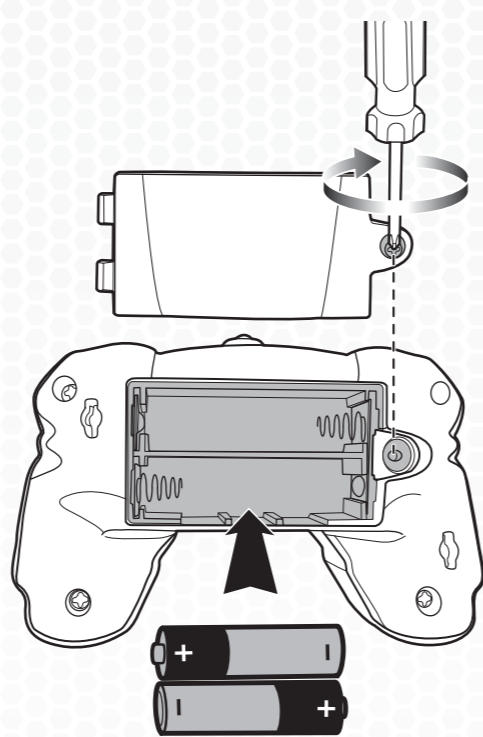

3 FEATURES

- ON (I) / OFF (O)
- BATTERY COVER
- STEERING ADJUSTER - Adjust, if necessary, to keep vehicle running straight

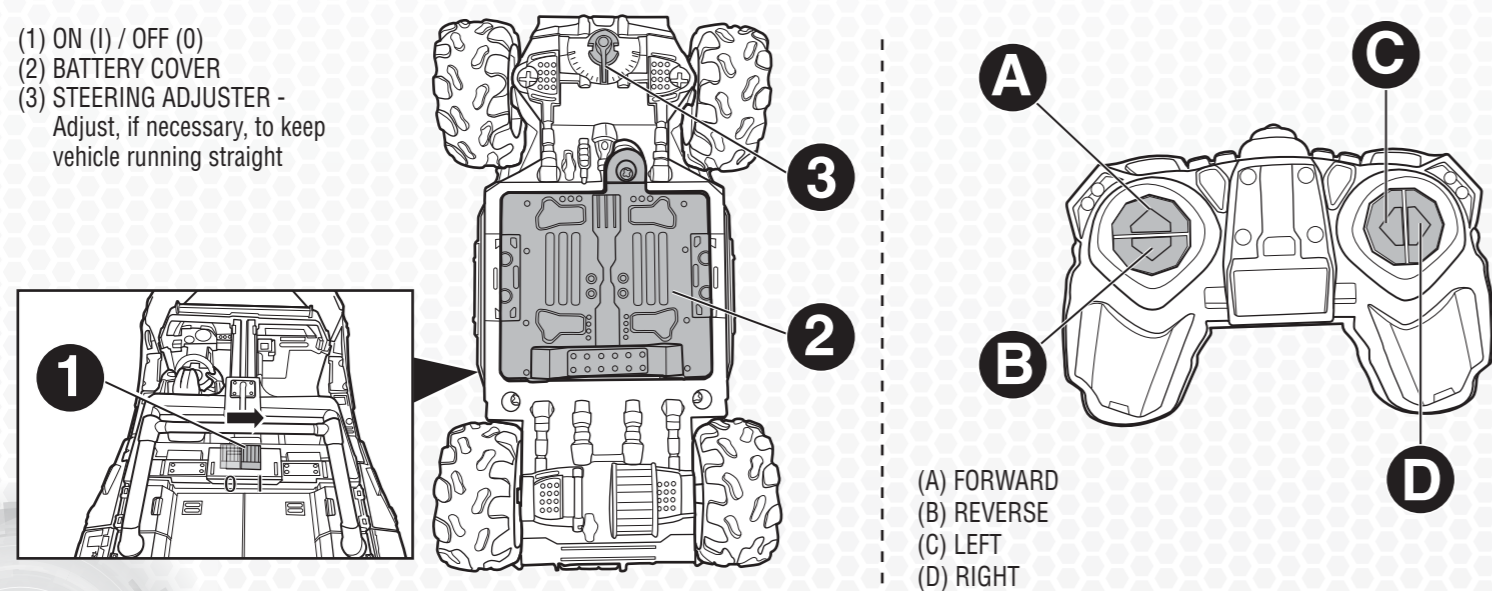

(A) FORWARD
(B) REVERSE
(C) LEFT
(D) RIGHT

2

4 OPERATIONS

NOTE: When playing with multiple vehicles, each set must be paired one at a time. Start with all vehicles turned OFF. Turn ON one vehicle. Press and release A on the corresponding transmitter to pair up. DO NOT START TO PLAY. Repeat these steps for each additional vehicle and transmitter. When all sets have been paired up, then you can start playing together.

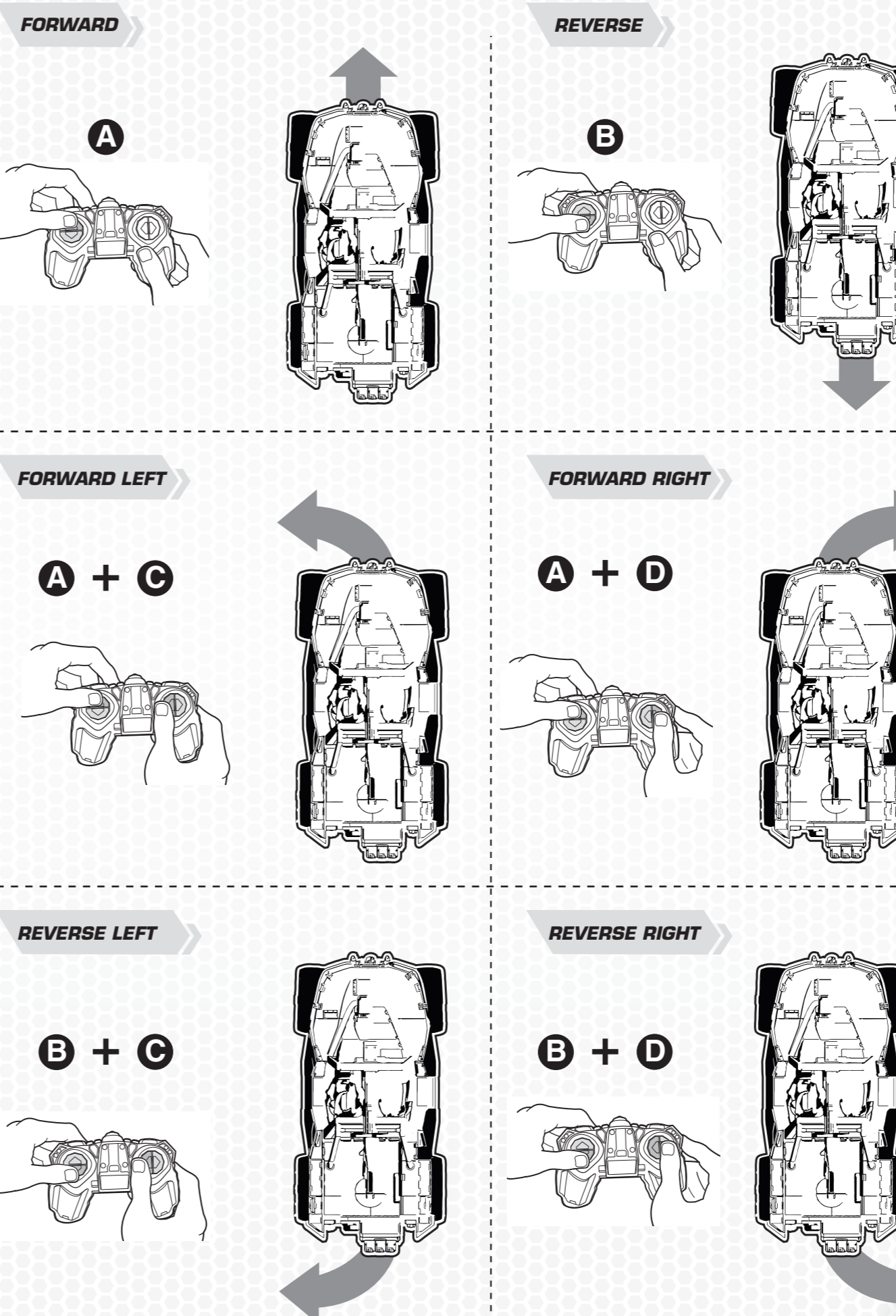

3