



Hot Wheels® R/C SUPPORT

Questions or problems with your product?
DON'T RETURN IT TO THE STORE!
 Just call us for help.

U.S. consumers may also register their products at this number.
1-888-557-8926

Asst.K9581
 K7237/38-0920

⚠ CAUTION: To prevent entanglement, keep hair away from wheels.

⚠ CAUTION: Surfaces may become hot and cause burns if electronics get wet. Do not operate vehicle through water or snow.

Keep these instructions for future reference as they contain important information. **IMPORTANT:** Please read all "Consumer Information" before operating your vehicle.

I. CONTENTS/ FEATURES

Vehicle
 Transmitter

Vehicle

Ⓐ Antenna

You will need to slip the loose antenna wire into the provided tube (it looks like a straw). Then push the straw (with wire already enclosed) firmly into the cylindrical opening on the chassis.

Ⓑ Steering adjuster

Turn with a screwdriver (not included) to keep vehicle running straight.

Ⓒ ON(I)/OFF(O) switch

Ⓓ Battery door

Ⓔ AA Battery adapter

Transmitter

⓫ Antenna

⓬ LED indicator(Light that indicates when your transmitter is turned on or off).

⓭ Steering knob: left / right control

⓮ Trigger: forward / reverse control

⓯ ON(I)/OFF(O) switch

⓶ Battery door

Just turn your vehicle ON. Then pull the trigger and you will be able to run and control your vehicle.

Pull trigger all the way back for that extra punch of power.

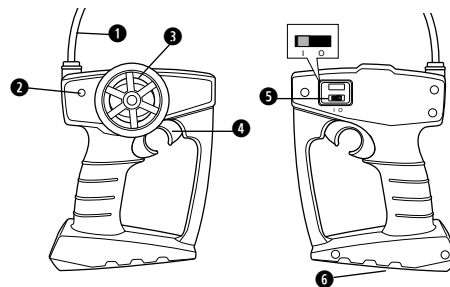
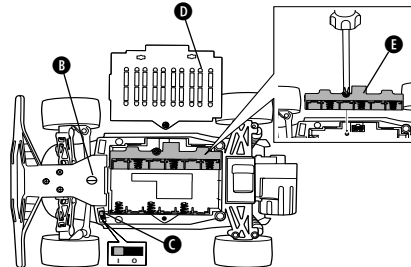
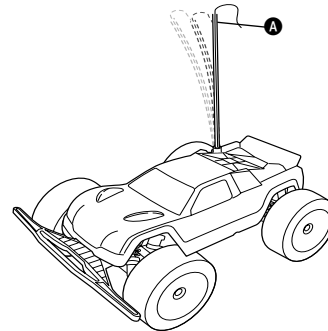

II. VEHICLE OPERATION

 If your vehicle doesn't move when you use the transmitter there's a good chance your vehicle's battery is ready for a recharge.

FORWARD

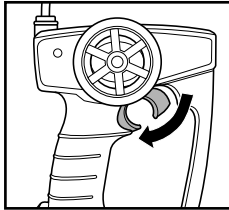

REVERSE

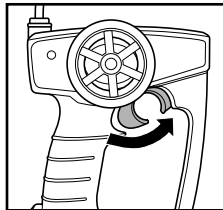

LEFT

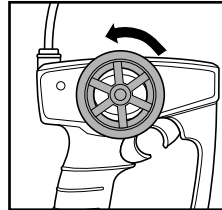

RIGHT

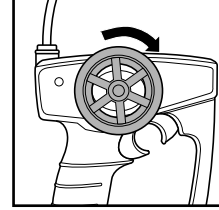

III. BATTERY INSTALLATION

Note: Your vehicle can be used with a Tyco® R/C 9.6V NiCd battery pack or 6 AA alkaline batteries.

Requires a Tyco® R/C 9.6V NiCd battery pack or 6 AA alkaline batteries for vehicle and 2 AA alkaline batteries for transmitter.

 Though your vehicle can run on both 9.6V or 6 x AA batteries it will run up to 30% faster when using a 9.6V rechargeable battery.

Vehicle

9.6V NiCd battery pack

1. Use a screwdriver (not included) to unscrew the battery cover.
2. Unscrew and remove the AA battery adapter. Store in a safe place for later usage.
3. Insert the 9.6V NiCd battery pack (not included), with polarity (+/-) as shown inside the battery compartment.
4. Plug the wire connector into the battery compartment as shown.
5. Replace the battery cover.

6 AA alkaline batteries

1. Use a screwdriver (not included) to unscrew the battery cover.
2. Make sure the AA battery adapter is firmly in place. If it's not, position the adapter in the box and fasten it with the screw.
3. Insert the 6 AA batteries (not included), with polarity (+/-) as shown inside the battery compartment.
4. Replace the battery cover.

Transmitter

1. Remove the battery cover as shown.
2. Install 2 AA batteries (not included), with polarity (+/-) as shown inside the battery compartment.
3. Replace the battery cover.

 If the transmitter's LED indicator does not light when the transmitter is switched ON, it's time to replace the transmitter batteries. Simply install fresh batteries as described above.

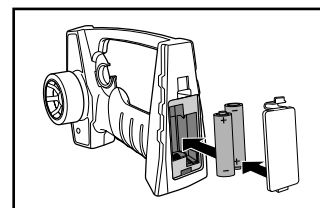
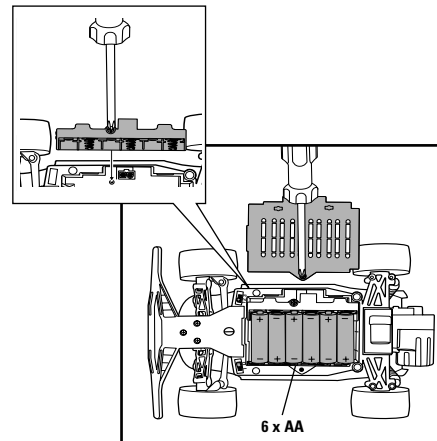
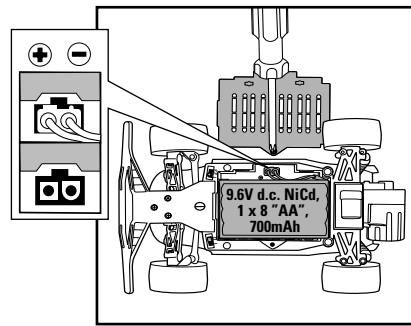

IV. QUICK TIPS

1. The best jumps are the ones where the rear wheels hit the ground first. It's important to give your vehicle just enough power as it leaves the ramp. Too much power and your nose will rise abruptly, too little and you'll land on the front wheels. When you do land, make sure all four wheels are on the ground before you accelerate. If you don't you may cause a wheelie, which may look really cool, but you'll lose time.
2. The vehicle was meant to fly high and land soft but just because you can doesn't mean you should – especially if you're in a race. Remember, the more time your vehicle spends in the air, the less time you'll have to accelerate. So stay low to win big!
3. Radio interference can affect your vehicle's performance. Interference can be caused by other R/C vehicles running on the same frequency, electrical wires, large buildings, CB radios or other wireless gear. Try to stay away from these!
4. Point your transmitter antenna up - not down toward your vehicle. If your vehicle gets too far away, it won't work properly.
5. Don't drive your vehicle through water or snow. If your vehicle does get wet, wipe it with a towel and allow it to dry completely.
6. Don't store your vehicle near heat or in direct sunlight. Always turn switches OFF and remove all batteries for storage.

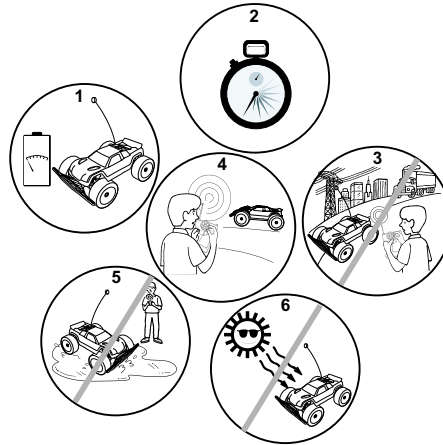

V. CONSUMER INFORMATION

Note to adults: To ensure that the child's play is both safe and fun, please review all operating instructions and safety rules with your child.

Safety Tips

- NEVER drive your vehicle on streets! They're for real cars!
- DO NOT pick up vehicle while in motion.
- Take your fingers off the transmitter trigger and then pick it up.
- Keep fingers, hair and loose clothing away from the tires and the wheel hubs while the vehicle is switched ON.
- Adult supervision is recommended when this vehicle is being operated.
- To avoid accidental operation, remove all batteries when not in use. Always turn the vehicle OFF before removing batteries.

BATTERY SAFETY INFORMATION

In exceptional circumstances batteries may leak fluids that can cause a chemical burn injury or ruin your product.

To avoid battery leakage:

- Non-rechargeable batteries are not to be recharged.
- Rechargeable batteries are to be removed from the product before being charged (if designed to be removable).
- Rechargeable batteries are only to be charged under adult supervision (if designed to be removable).
- Do not mix alkaline, standard (carbon-zinc), or rechargeable (nickel-cadmium) batteries.
- Do not mix old and new batteries.
- Only batteries of the same or equivalent type as recommended are to be used.
- Batteries are to be inserted with the correct polarity.
- Exhausted batteries are to be removed from the product.
- The supply terminals are not to be short-circuited.
- Dispose of battery(ies) safely.
- Do not dispose of this product in a fire. The batteries inside may explode or leak.

Battery Performance Note:

For the best possible performance use a 9.6V NiCd battery and get up to a 30% more speed. You can also use regular or high-performance alkaline batteries (where disposable batteries are called for). If your vehicle is supplied with standard (carbon-zinc) batteries for initial use and/or demonstration purposes, we recommend replacing them with alkaline batteries when necessary. Battery life may vary depending on battery brand.



Protect the environment by not disposing of this product with household waste (2002/96/EC). Check your local authority for recycling advice and facilities.

90 DAY LIMITED WARRANTY – Hot Wheels® R/C PRODUCTS

Mattel, Inc. warrants to the original consumer purchaser that this product will be free of defects in material and workmanship for ninety (90) days (unless specified in alternate warranties) from the date of purchase. Mattel will repair or replace the product, at our sole option, in the event of such a defect within the warranty period.

In the event of a defect covered under this warranty, first call the toll-free number listed below. Many problems can be solved in this manner. If necessary, you will be instructed to return the product, postage prepaid and insured, to the address below. Enclose your name, address, dated sales receipt, and a brief explanation of the defect. Repair or replacement, and return shipment, will be free of charge. Please return only the defective part or unit, packed securely.

This warranty does not cover damage resulting from unauthorized modification, accident, misuse or abuse. If the product is returned without a dated sales receipt, the product may be excluded from coverage under this warranty.

Mattel's liability for defects in material and workmanship under this warranty shall be limited to repair or replacement, at our sole option, and in no event shall we be responsible for incidental, consequential, or contingent damages (except in those states that do not allow this exclusion or limitation). This warranty is exclusive, and is made in lieu of any express or implied warranty. This warranty gives you specific legal rights and you may have other rights, which vary from state to state. Some states do not allow the exclusion of incidental or consequential damages, so the above exclusions or limitations may not apply to you.

TOLL-FREE NUMBER: 1-888-557-8926 - **Valid only in U.S.A.**

Hours: 8:00 A.M.-5:00 P.M. Eastern Time; Monday - Friday. Expect some delay in January following the holiday season. Please be patient and keep trying the toll-free number.

ADDRESS FOR RETURNS:
CONSUMER RELATIONS
636 GIRARD AVENUE
EAST AURORA, NY 14052

Valid only in U.S.A.

© 2006 Mattel, Inc., 333 Continental Blvd., El Segundo, CA 90245 U.S.A.
Consumer Relations 1-888-557-8926 **PRINTED IN CHINA** service.mattel.com.
• Mattel Canada Inc., Mississauga, Ontario L5R 3W2 • [Mattel U.K. Ltd. Vanwall](http://Mattel.U.K.Ltd.Vanwall)
[Business Park, Maidenhead SL6 4UB](http://Business.Park.Maidenhead.SL6.4UB), Helpline 01628500303 • Mattel Australia Pty, Ltd., Richmond, Victoria. 3121. Consumer Advisory Service - 1300 135 312.
• Mattel East Asia Ltd., Room 1106, South Tower, World Finance Centre, Harbour City, Tsimshatsui, HK, China. • Diimport & Diedarkan Oleh: Mattel SEA Ptd Ltd.(993532-P) Lot 13.5, 13th Floor, Menara Lien Hoe, Persiaran Tropicana Golf Country Resort, 47410 PJ. Tel:03-78803817, Fax:03-78803867.

COMPLIANCE WITH FCC REGULATIONS (VALID IN U.S. ONLY)

This device complies with part 15 of the FCC Rules. Operation is subject to the following two conditions: (1) This device may not cause harmful interference, and (2) this device must accept any interference received, including interference that may cause undesired operation. This device generates and uses radio frequency energy and if not used properly may cause interference to radio and television reception. It has been tested and found to comply with the limits set by the FCC which are designed to provide reasonable protection against such interference.

NOTE: Changes or modifications not expressly approved by the manufacturer responsible for compliance could void the user's authority to operate the equipment.