

FEATURES

- Multi function
- Available in 2 frequencies: 27 MHz and 49 MHz (refer to labels on transmitter & vehicle for frequency)
- Range up to 30'/9m

SIDE VIEW

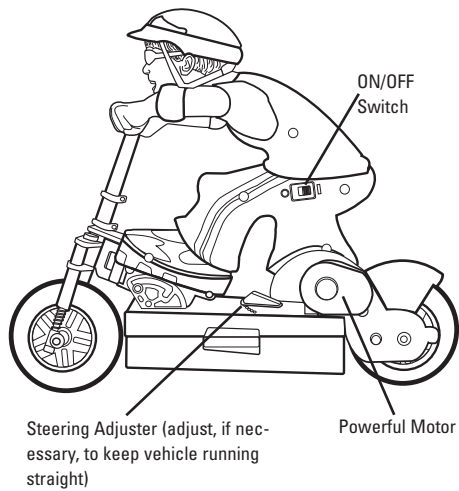

BOTTOM VIEW

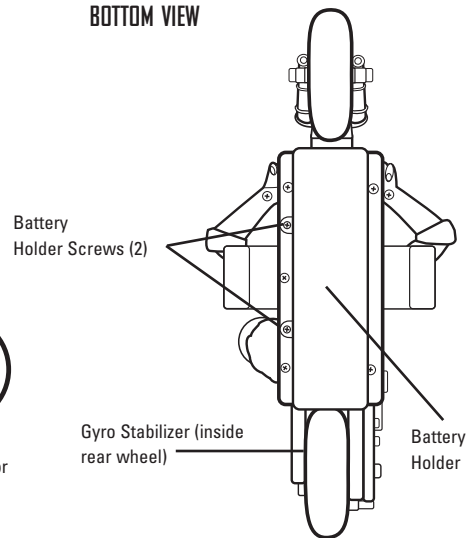

II. QUICK START

 Please read this Owner's Manual thoroughly.

1. Start with a fresh set of batteries.
2. Turn vehicle switch ON. Press transmitter controls to run and control your vehicle.
3. When you're done driving, turn vehicle switch OFF. Remove all batteries for storage.

III. OPERATING YOUR VEHICLE

FORWARD

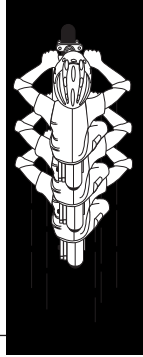

BRAKING

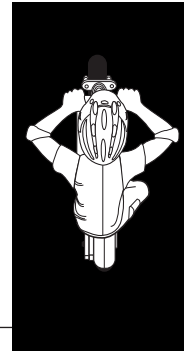

LEFT TURN



RIGHT TURN



IV. QUICK TIPS

- ∂ When your vehicle starts to lose power, it may lose functions or performance. It's time for fresh batteries. Your vehicle's running time may change depending on your driving style.
- Σ Radio interference can make your vehicle run badly. Interference can be caused by other R/C vehi-

cles running on the same frequency; electrical wires; large buildings; or CB radios. Try to stay away from these!

- Π Point your transmitter antenna up - not down toward your vehicle. If your vehicle gets too far away, it won't work properly.

- π Don't drive your vehicle in sand or through water or snow. If your vehicle does

get wet, wipe with a towel and allow to dry completely.

- ∫ Don't store your vehicle near heat or in direct sunlight. Always turn switch OFF and remove all batteries for storage.

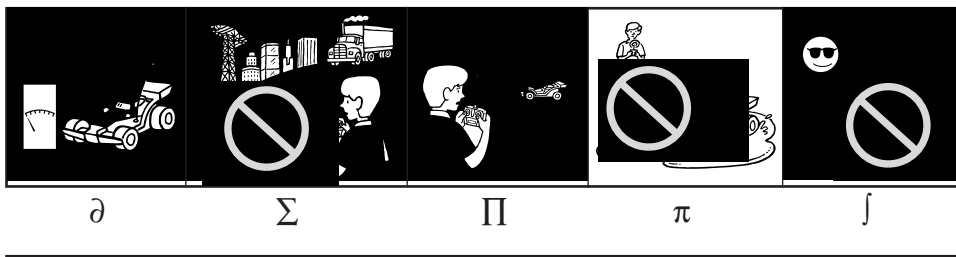

© 2001 Mattel, Inc., Mt. Laurel, NJ 08054 U.S.A. **PRINTED IN CHINA.** All Rights Reserved. ® and ™ designate U.S. trademarks of Mattel, Inc.

Retain this address for future reference: Mattel U.K., Ltd., Vanwall Business Park, Maidenhead SL6 4UB. Mattel Australia Pty., Ltd., Richmond, Victoria 3121 - Consumer Advisory Service: 1800 800 812 (valid only in Australia). Mattel East Asia Limited, 930 Ocean Centre, Harbour City, HK, China.

COMPLIANCE WITH FCC REGULATIONS

THIS DEVICE COMPLIES WITH PART 15 OF FCC RULES. OPERATION OF THIS DEVICE IS SUBJECT TO THE FOLLOWING TWO CONDITIONS:

- (1) THIS DEVICE MAY NOT CAUSE HARMFUL INTERFERENCE.
- (2) THIS DEVICE MUST ACCEPT ANY HARMFUL INTERFERENCE THAT MAY CAUSE UNDESIRED OPERATION.

This device generates and uses radio frequency energy and if not used properly may cause interference to radio and television reception. It has been tested and found to comply with the limits set by the FCC, which are designed to provide reasonable protection against such interference.



CAUTION: Changes or modifications not expressly approved by the manufacturer responsible for compliance could void the user's authority to operate the equipment.

**90-DAY LIMITED WARRANTY
TYCO® R/C PRODUCTS**

Mattel, Inc. warrants to the original consumer purchaser that this product will be free of defects in material and workmanship for ninety (90) days (unless specified in alternate warranties) from the date of purchase. Mattel will repair or replace the product, at our sole option, in the event of such a defect within the warranty period.

In the event of a defect covered under this warranty, first call the toll-free number listed below. Many problems can be solved in this manner. If necessary, you will be instructed to return the product, postage prepaid and insured, to the address below. Enclose your name, address, dated sales receipt, and a brief explanation of the defect. Repair or replacement, and return shipment, will be free of charge. Please return only the defective part or unit, packed securely.

This warranty does not cover damage resulting from unauthorized modification, accident, misuse or abuse. If the product is returned without a dated sales receipt the product may be excluded from coverage under this warranty.

Mattel's liability for defects in material and workmanship under this warranty shall be limited to repair or replacement, at our sole option, and in no event shall we be responsible for incidental, consequential, or contingent damages (except in those states that do not allow this exclusion or limitation). This warranty is exclusive, and is made in lieu of any express or implied warranty. **Valid only in U.S.A.** This warranty gives you specific legal rights and you may have other rights, which vary from state to state. Some states do not allow the exclusion of incidental or consequential damages, so the above exclusions or limitations may not apply to you.

TOLL-FREE NUMBER: 1-888-557-TYCO (8926) **(valid only in U.S.A.)**

Hours: 8:00 A.M. - 6:00 P.M. Eastern Time; Monday - Friday. Expect some delay in January following the holiday season. Please be patient and keep trying the toll-free number.

ADDRESS FOR RETURNS:

CONSUMER RELATIONS, 636 GIRARD AVENUE, EAST AURORA, NY 14052.