

Industrial II

19" Rackmount

Ultra 2 SCSI to IDE
Disk Array System

User's Guide

Version 8.21
July 2000

A9-8200

19" Rackmount

Ultra 2 SCSI to IDE
Disk Array System

User's Guide

Version 8.21
July 2000

***** USER'S MANUAL *****

FCC ID : NKF-IND II

Federal Communications Commission (FCC) Statement

This equipment has been tested and found to comply with the limits for a Class B digital device, pursuant to Part 15 of the FCC Rules. These limits are designed to provide reasonable protection against harmful interference in a residential installation. This equipment generates, uses and can radiate radio frequency energy and, if not installed and used in accordance with the instruction, may cause harmful interference to radio communications. However, there is no guarantee that interference will not occur in a particular installation. If this equipment does cause harmful interference to radio or television reception, which can be determined by turning the equipment off and on, the user is encouraged to try to correct the interference by one or more of the following measures:

- Reorient or relocate the receiving antenna.
- Increase the separation between the equipment and receiver.
- Connect the equipment into an outlet on a circuit different from that to which the receiver is connected.
- Consult the dealer or an experienced radio / TV technician for help.

Warning : A shielded-type power cord is required in order to meet FCC emission limits and also to prevent interference to the nearby radio and television reception. It is essential that only the supplied power cord be used.

Use only shielded cables to connect I/O devices to this equipment.

You are cautioned that changes or modifications not expressly approved by the party responsible for compliance could void your authority to operate the equipment.

Copyright Notice

© 2000 MaxTronic International Co., Ltd. All rights reserved.
No part of this written material may be reproduced, stored in a retrieval system, used in any form or by any means, electronic or mechanical, photocopying, recording, or otherwise, without the written permission of MaxTronic International CO., LTD.

Important ! Safety Instructions, Care and Handling



1. Before starting, take a few minutes to read this manual, read all of these instructions and save this manual for later reference.



2. Protect the Disk Array from extremely high or low temperatures. Let the Disk Array warm (or cool) to room temperature before using it.



3. Protect the Disk Array from being bumped or dropped. Do not place this product on an unstable cart, stand, or table. It may fall, causing serious damage to the product.



4. Keep the Disk Array away from magnetic forces.



5. Do not use this product near water.



6. Keep the Disk Array away from dust, sand, or dirt.



7. Gaps and openings in the cabinet and the back are provided for ventilation. To ensure reliable operation and to protect it from overheating, the gaps and openings should never be blocked or covered by placing the product on a bed, sofa, rug, or other similar surface.



8. Do not place this product near or over a radiator or heat register.



9. Refer to rating plate for voltage and check that the appliance voltage corresponds to the supply voltage.



10. The appliance must be grounded. This product is equipped with a 3wire grounding-type power cord, this power cord will only fit into a groundingtype power outlet.



11. If an extension cord or a power center is used with this product, make sure that the total of all products plug into the wall outlet does not exceed the ampere rating.



12. Do not place the Disk Array where the cord will be walked on.



13. Never push any kind of object into this product through cabinet gaps and openings, they may touch dangerous voltage points cause a risk of fire or electric shock.

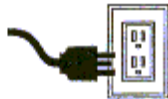

14. Unplug the power cord from the wall outlet before cleaning. Keep the Disk Array dry. Do not use liquid cleaners, aerosol cleaners, or a wet cloth. Use a damp cloth for cleaning.



15. Except as specifically explained in this User's Manual, please do not attempt to service this product by yourself. Opening or removing the covers may expose you to dangerous voltages.



16. Unplug this product from the wall outlet and refer servicing to qualified service personnel under the following conditions :
- If this product has been exposed to water or any liquid.
 - If the product has been dropped or the cabinet damaged.

Contents

Chapter 1 : Introduction

Features	1-2
General RAID concepts	1-4
RAID Level 0	1-5
RAID Level 1	1-7
RAID Level 3	1-8
RAID Level 5	1-10
Summary Comparison of RAID Levels	1-12
Supported RAID Levels	1-13
Multi-SCSI Format support	1-14

Chapter 2 : Getting Started

General Overview	2-1
Unpacking & Checklist	2-2
Choosing a place for Disk Array	2-3
Identifying Parts of Disk Array	
Front View	2-4
Rear View	2-5
Power Source	2-6
Installing the Hard Disk Drive	2-7
Host Linkage	2-10
Power-On & Self-Test	2-11
LED Display & Function Keys	
LED Display	2-12
Function Keys	2-13
LCD Status Panel	2-14

Chapter 3 : Configuration

General Overview	3-1
Configuration from the front Panel	3-2

Configuration Procedures	3-3
Starting the Configuration	3-4
Configuration from VT100 Terminal Mode	3-7
Configuration Procedures	3-8
Main Screen	3-9
Re-config RAID	3-10
Set RAID Level	3-11
Hot Spare Disk	3-12
Set SCSI ID#	3-13
Termination	3-14
Password	3-15
Save & Restart	3-16

Chapter 4 : Advanced Information

Memory Expansion	4-2
RAID Controller Block Diagram	4-5
Updating Firmware	4-6
Setting Up VT100 Terminal Emulation in Windows 95®	4-7
Start to Update Firmware	4-14

Chapter 5 : Hot Swap

Removing / Installing Hard Disk Drive	5-2
Removing / Installing Redundant Power Supply Unit	5-6
Removing / Installing Cooling Fan	5-9

Appendix :

Technical Specifications	A-1
--------------------------------	-----

Chapter 1 : " Introduction "

This chapter will introduce you to your new Disk Array's features and provide information on general RAID concept.

Features

This section provides an overview of the features. For more detailed information, please refer to the technical specifications appendix at the end of this manual .

Your Disk Array includes the following features :

Easy Operation

As everyone knows, conventional Disk Arrays are designed for experienced computer specialists. To solve complicated and time consuming operating procedures, we came up with a revolutionary idea :

-- Innovative Plug And Play RAID --

As compared to a conventional Disk Array's long-winded setup procedures, Arena can be ready to go after using the simple step by step built-in setup program.

Ultra High performance

Your Disk Array combines an extremely high speed microprocessor with the latest chip set, SCSI hardware technology , perfect firmware and an artistic design. The result is one of the fastest, most reliable Disk Array systems on the market.

- Supports virtually all popular operating systems ,platforms and network environments because it works independently from the O.S.
- Ultra 2 LVD SCSI channel interface to your Host computer, up to 80MB data transfer rate provides the processing and access power for you to handle complex and large files.
- Selective SCSI ID 0 ~ 15 , support with active termination.
- Tagged-command queuing : allows processing of up to 255 simultaneous data requests.
- Selective RAID levels 0, 1, 0+1, 3 or 5.
- Build-in 64MB cache memory, expandable up to 128MB.
- Serial communication port (Terminal Port) permits array controller operation through a standard VT100 terminal (or equivalent).

Solid reliability

- Automatic failed disk drive detection.
- Auto rebuild : when a replacement disk installed (or by using hot spare disk), The system provides automatic data rebuild without any commands or functions keyed in. (Transparent to Host)

Efficient maintenance

- An LCD status panel displays a comprehensive readout of the operating status, and the HDD LED indicators on each HDD tray display the individual HDD status.
- When disk failure occurs on a member disk of the disk array, the built-in buzzer sounds simultaneously and LCD status panel also points out the location of the failed hard disk drive. In the meantime the LED HDD status indicator will light up " Red "on the failed HDD tray , according the LED indicator on the HDD tray you can perform quick, efficient and correct maintenance.
- Hot Swap : allows you can remove and install the " Hot Swap " parts without interrupting data access while the system is on.
- The " Hot Swap " parts include the Hard Disk Drive, Redundant Power Supply Unit and Cooling Fan.

General RAID Concepts

Correct installation of the disk array requires an understanding of RAID technology and the concepts described in this section.

Definition

RAID is an acronym of Redundant Array of Independent Disks . A RAID is a Disk Array in which part of the storage capacity is used to record redundant information about the user data stored on the remainder of the storage capacity. The redundant information enables regeneration of user data in the event that one of the Array's member Disks or the access path to it fails.

Benefits of RAID

1. Secure Data

RAID is an emerging storage technology with the potential to revolutionize the data storage technology. A typical RAID unit contains a set of disk drives, typically two to six, which appear to the user to be equivalent to a single large capacity disk drive. The remarkable benefit of disk array is that if any single disk in the RAID fails, the system and array still continues to function without loss of data. This is possible because the redundancy data is stored on separate disk drives and the RAID can reconstruct the data that was stored on the failed disk drive.

2. Increases system performance

As the effective seek time for finding data on a disk can potentially be reduced by allowing multiple simultaneous access of different data on different disks. Utilizing parallel reads and writes of the data spread across the disks in the array, the data transfer rate can be increased significantly over that of a single disk.

3. Easy maintenance

RAID system maintenance is typically simplified because it is easy to replace individual disks and other components while the system continues to function. (Hot swap support)

RAID Levels

RAID Level 0 : " Disk Striping " High I/O Performance

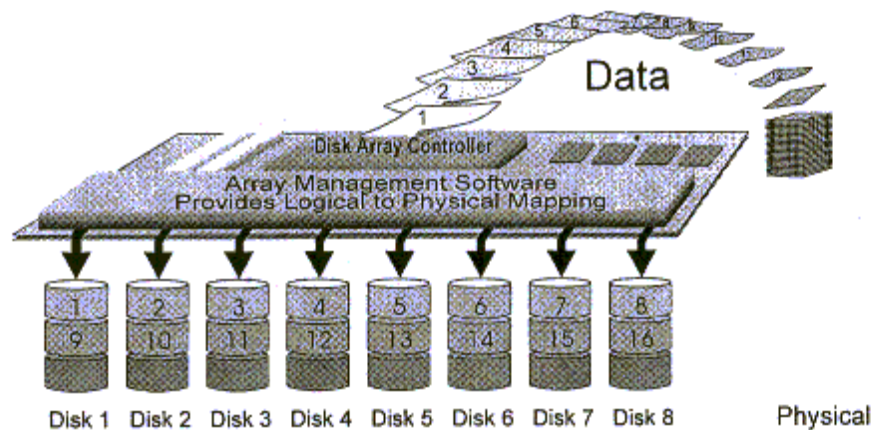

- Improved I/O performance is the major reason for using RAID level 0.

No protection is provided against data loss due to member disk failures. A RAID level 0 array by itself is thus an unsuitable storage medium for data that can not easily be reproduced, or for data that must be available for critical system operation. It is more suitable for data that can be reproduced or is replicated on other media.

A RAID level 0 array can be particularly useful for :

- Storing program image libraries or runtime libraries for rapid loading, these libraries are normally read only.
- Storing large tables or other structures of read only data for rapid application access. Like program images, the data should be backed up on highly reliable media, from which it can be recreated in the event of a failure.
- Collecting data from external sources at very high data transfer rates.

- RAID level 0 arrays are not particularly suitable for :
 - Applications which make sequential requests for small amount of data. These applications will spend most of their I/O time waiting for disks to spin, whether or not they use striped arrays as storage media.
 - Applications which make synchronous random requests for small amounts of data.

RAID Level 1 : " Disk Mirroring " High Data reliability

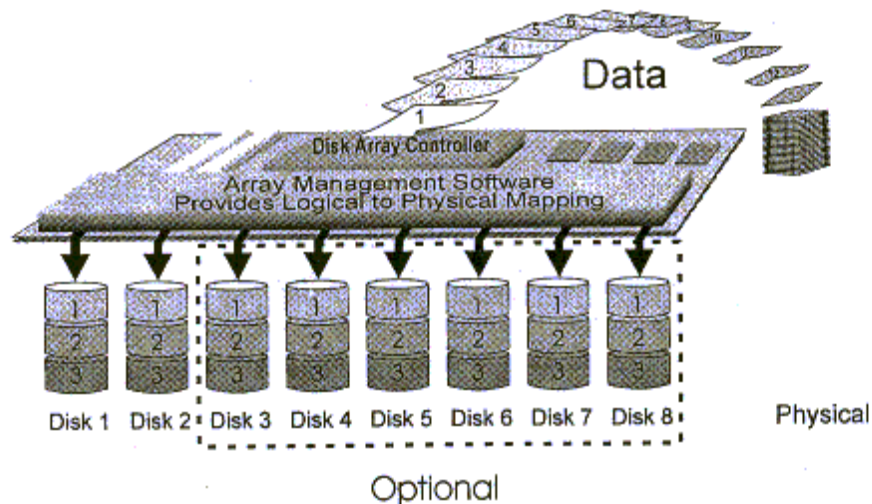

RAID level 1 provides both very high data reliability and continued data availability in the event of a failure of an array member. When a RAID level 1 member disk fails, array management software simply directs all application requests to the surviving member.

RAID level 1 is suitable for data for which reliability requirements are extremely high, or for data to which high performance access is required, and for which the cost of storage is a secondary issue.

RAID Level 3 :

" Parallel Transfer Disks with Parity "

High Data Reliability & Highest Transfer Capacity

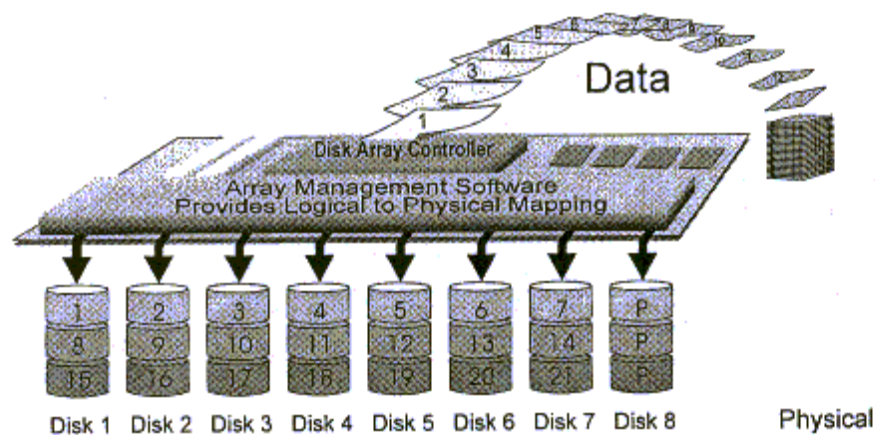

P : Parity

RAID Level 3 technology use a dedicated parity disk to store redundant information about the data on several data disks. RAID Level 3 is an excellent choice for applications which require single stream I/O with a high data transfer rate.

RAID Level 3 is optimal for applications in which large block of sequential data must be transferred quickly, these applications are usually of one of these types :

- They operate on large data objects such as graphical image processing, CAD/CAM files, and others.
- They are non-interactive applications that process large data sequentially.

They usually request a large amount of data (32KBytes or more) with each I/O request.

- The distinctive performance characteristics of RAID Level 3 :
 - RAID Level 3 provides excellent performance for data transfer-intensive applications.
 - RAID level 3 is not well suited for transaction processing or other I/O request-intensive applications.

RAID Level 5 :

" Independent Access Array with Rotating Parity "
High Data Reliability & Transfer Capacity

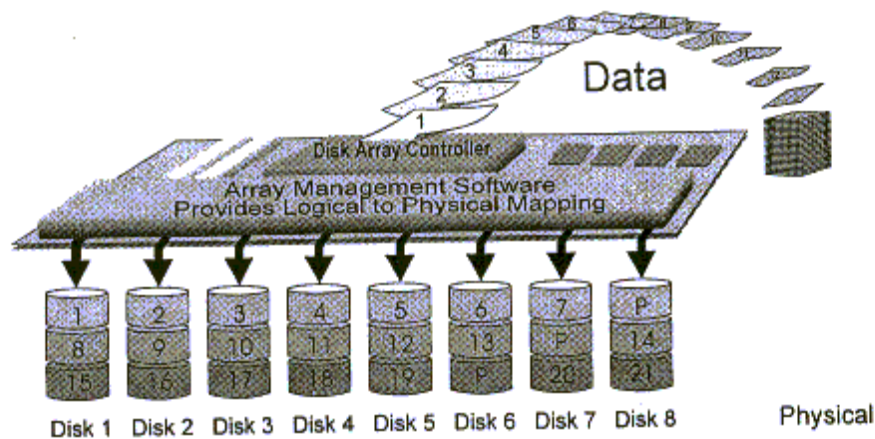

P : Parity

When RAID Level 5 technology is combined with cache memory to improve its write performance, the result can be used in any applications where general purpose disks would be suitable.

For read only or read mostly application I/O loads, RAID Level 5 performance should approximate that of a RAID Level 0 array. In fact, for a given user capacity, RAID Level 5 read performance should normally be slightly better because requests are spread across one more members than they would be in a RAID Level 0 array of equivalent usable capacity.

- A RAID level 5 array performs best in applications where data and I/O load characteristics match their capabilities :
 - Data whose enhanced availability is worth protecting, but for which the value of full disk mirroring is questionable.
 - High read request rates.
 - Small percentage of writes in I/O load.

- RAID level 5 arrays have unique performance characteristics :
 - The data can be recalculated or regenerated, using parity, when any drive in the array fails.
 - When the failed drive is replaced, either automatically if the subsystem contained a hot spare drive, or by user intervention during a scheduled maintenance period, the system will be restored its full data redundancy configuration by rebuilding all of the data that had been stored on the failed drive onto the new drive. This is accomplished using parity information and data from the other data disks. Once the rebuild process is complete, all data is again protected from loss due to any failure of a single disk drive.

Summary Comparison of RAID Levels

RAID Level	Common Name	Description	Array's Capacity	Data Reliability	Data Transfer Capacity
0	Disk Striping	Data distributed across the disks in the array. No redundant information provided.	(N) disks	Low	Very High
1	Mirroring	All data Duplicated	1*disk	Very High	High
3	Parallel Transfer Disks with Parity	Data sector is subdivided and distributed across all data disk. Redundant information stored on a dedicated parity disk.	(N-1) disks	Very High	Highest of all listed alternatives
5	Independent Access Array with Rotating Parity	Data sectors are distributed as with disk striping, redundant information is interspersed with user data.	(N-1) disks	Very High	Very High

Supported RAID Levels

Based on the needs of a Disk Array's capacity, data availability, and overall performance, you can select a proper RAID level for your Disk Array. The supported RAID levels are shown in below :

RAID Level	Function Description	Drives required	
		Min.	Max.
0	"Disk Striping" , block striping is used, which yields higher performance than with the individual disk drives. * There is no redundant function.	2	8
1	"Disk Mirroring" , Disk drives are mirrored , All data is 100% duplicated on each equivalent disk drives. * High Data Reliability	2	8
3	" Parallel Transfer Disks with Parity " , Data is striped across physical drives. Parity protection is used for data redundancy.	3	8
5	" Independent Access Array with Parity " , Data is striped across physical drives. Rotating Parity protection is used for data redundancy.	3	8
0+1	" Disk Striping " + " Disk Mirroring " Function.	4	8

Multi-SCSI Format support

The Disk Array provides one LVD Ultra 2 SCSI channel for connecting to your host system. With proper cabling, it may support Narrow or Wide; Standard, Fast or Ultra SCSI formats. (single ended)

Overall cable length

For secure data transfer , please refer to the cable length limitations as below :

- * Cable length = External Host cables length + Internal Host cable length
- * Standard Disk Array External cable length = 90cm (3 ft)
- * Standard Disk Array Internal cable length = 20cm

SCSI Type	Clock Rate	Data Rate	Maximum Cable Length	Cable Required	Remark
LVD Ultra 2 (16 bit)	40 MHZ	80 MB/sec	12m	HPD 68--- HPD 68 pin	
Ultra wide (16 bit)	20 MHZ	40 MB/sec	2m	HPD 68--- HPD 68 pin	
Ultra SCSI (8 bit)	20 MHZ	20 MB/sec	2m	HPD 68--- HPD 50 pin	
Narrow SCSI2 (8 bit)	10 MHZ	10 MB/sec	3m	HPD 68--- Cen. 50 pin	
SCSI1 (8 bit)	5 MHZ	5 MB/sec	5m	HPD 68--- Cen. 50 pin	

Chapter 2 : " Getting Started "

General Overview

This chapter helps you get ready to use the Disk Array. It gives you :

- Unpacking & Checklist
- Choosing a place for Disk Array
- Identifying Parts of Disk Array
- Power Source
- Installing the Hard Disk Drives
- Host Linkage
- Power-On and Self-test
- LED Display and Function Keys
- LCD Status Display

The following illustrations will help you read the further sections.

Unpacking & Checklist

Before unpacking your Disk Array , prepare a clean and stable place to put the contents of your Disk Array's shipping container on. Altogether, you should find the following items in the package :

- The Disk Array
- One AC power cord
- One External SCSI cable
- Keys (For HDD Trays)
- User Manual

Remove all the items from the carton. If anything is missing or broken , please inform your dealer immediately. Save the cartons and packing materials that came with the Disk Array. Use these materials for shipping or transporting the Disk Array.

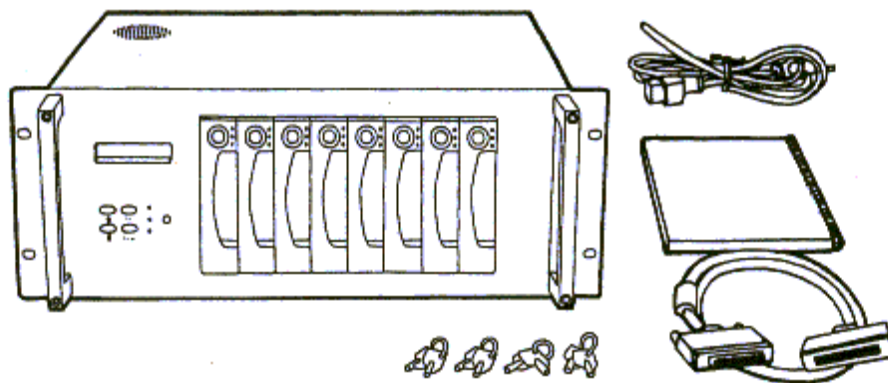

Figure : Checklist

Choosing a place for Disk Array

When selecting a place to set up your Disk Array, be sure to follow the guidelines as below:

- Place on a flat and stable surface.
- Use a stand that supports at least 50 kgs for this Disk Array. (HDD included)
- Place the Disk Array close enough to the computer for the Disk Array's External SCSI cable to reach it.
- Use a grounded wall outlet.
- Avoid an electrical outlet controlled by wall switches or automatic timers. Accidental disruption of the power source may wipe out data in the memory of your computer or Disk Array.
- Keep the entire system away from potential sources of electromagnetic interference, such as loudspeakers , cordless telephones, etc.
- **Caution !**
Avoid direct sunlight, excessive heat, moisture, or dust.

Identifying Parts of the Disk Array

Front View

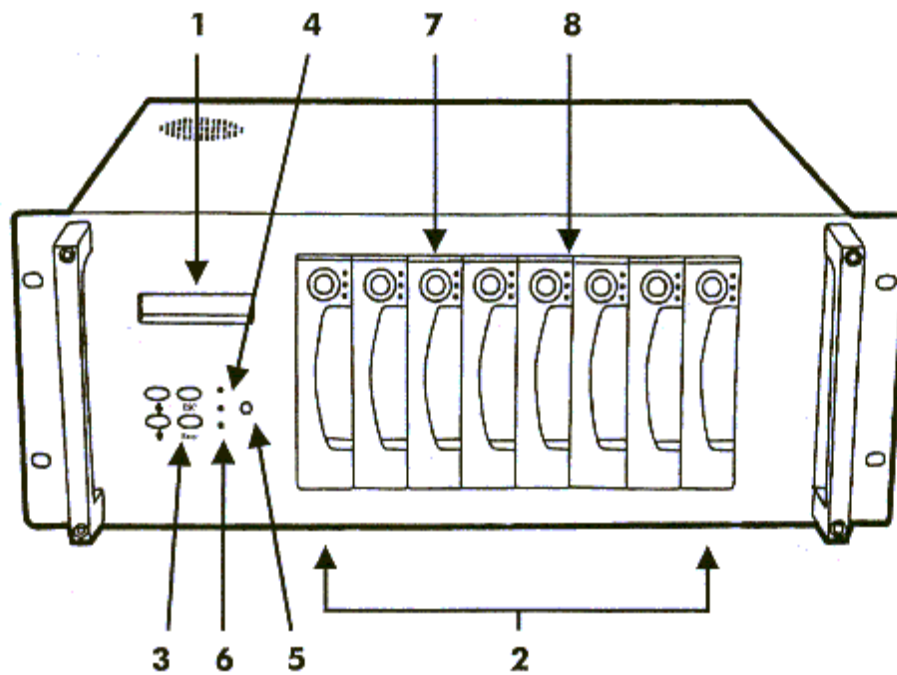

Figure : Front View

1. LCD Status Display Panel
2. HDD Trays 1 ~ 8
3. Function Keys (↑ , ↓ , Enter , ESC)
4. Power-On Indicator (PWR Unit 1 , PWR Unit 2)
5. Power Supply " Alarm " Reset
6. Host Computer Access Indicator
7. HDD Tray Lock (Lock / Unlock)
8. HDD Status Indicator
(From low to up: Error (Red), Access (Yellow), Power-On (Green))

REAR VIEW

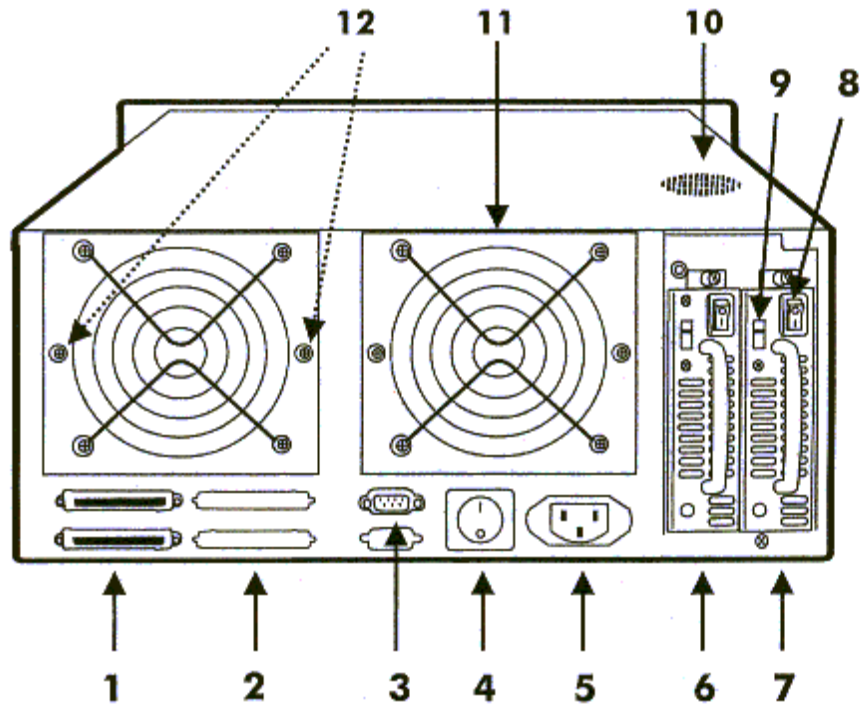

Figure : Rear View

1. Host Channel adaptor Port
2. Reserved #2 Host Channel port
3. RS-232 Adapter (Terminal Port)
4. Power Supply Main Switch (O / I)
5. AC Power Input Socket
6. Power Supply Unit 1
7. Power Supply Unit 2
8. Power Supply Unit Switch (O / I)
9. AC Voltage Select Switch (115V/230V)
10. Venthole for Power Supply
11. Cooling Fan
12. Fan Door Screws

Power Source

Choosing a Working Voltage

The system can run either on AC 110V (+/10%) or AC 220V (+/10%). Slide the AC voltage select switch on both of the two power supply units to the correct position which corresponds with the wall outlet supply voltage.

Warning !

Wrong AC Voltage input will harm the power supply and cause serious damage to the Disk Array.

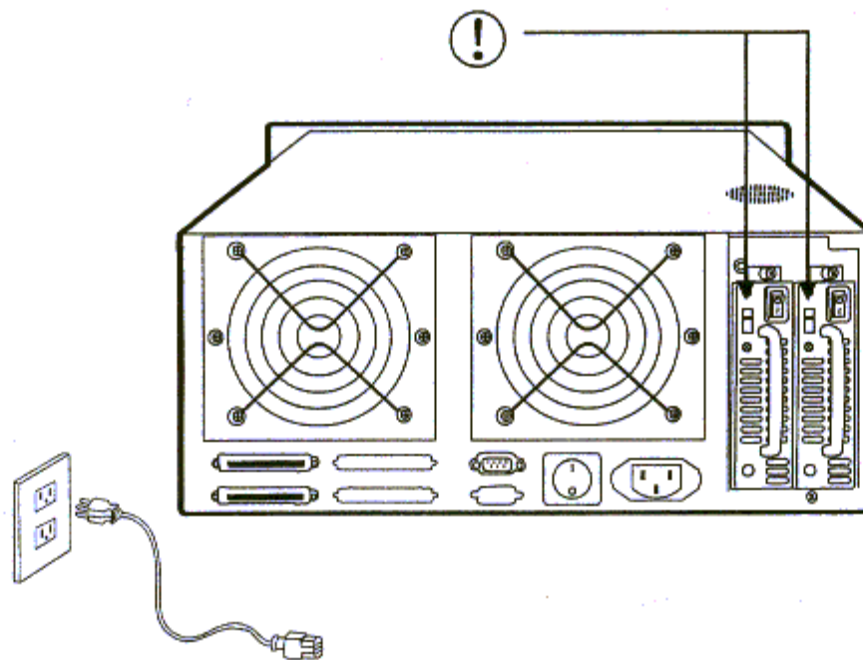

Figure : Power Source

This Disk Array must be grounded

This Disk Array is supplied with an AC power cord equipped with a 3-wire grounding type plug. This is a safety feature and it is important to only use a 3-wire grounded mains power cord.

Installing the Hard Disk Drives

- Step 1 : Unlock the HDD tray by turning the Key-lock to the correct position.
- Step 2 : Gently Pull out the HDD tray.

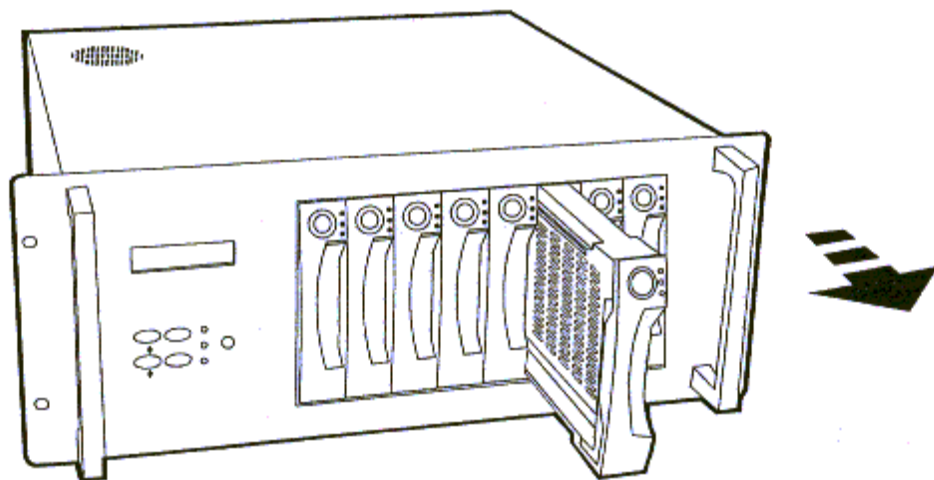

Figure : Installing HDD step 1, 2

Getting Started

Step 3 : Insert HDD into the tray

Step 4 : Screw in the hard drive.
(Use the correct size, type and thread)

Step 5 : Cabling, Connect the Data cable , SCSI ID cable
& Power cable.

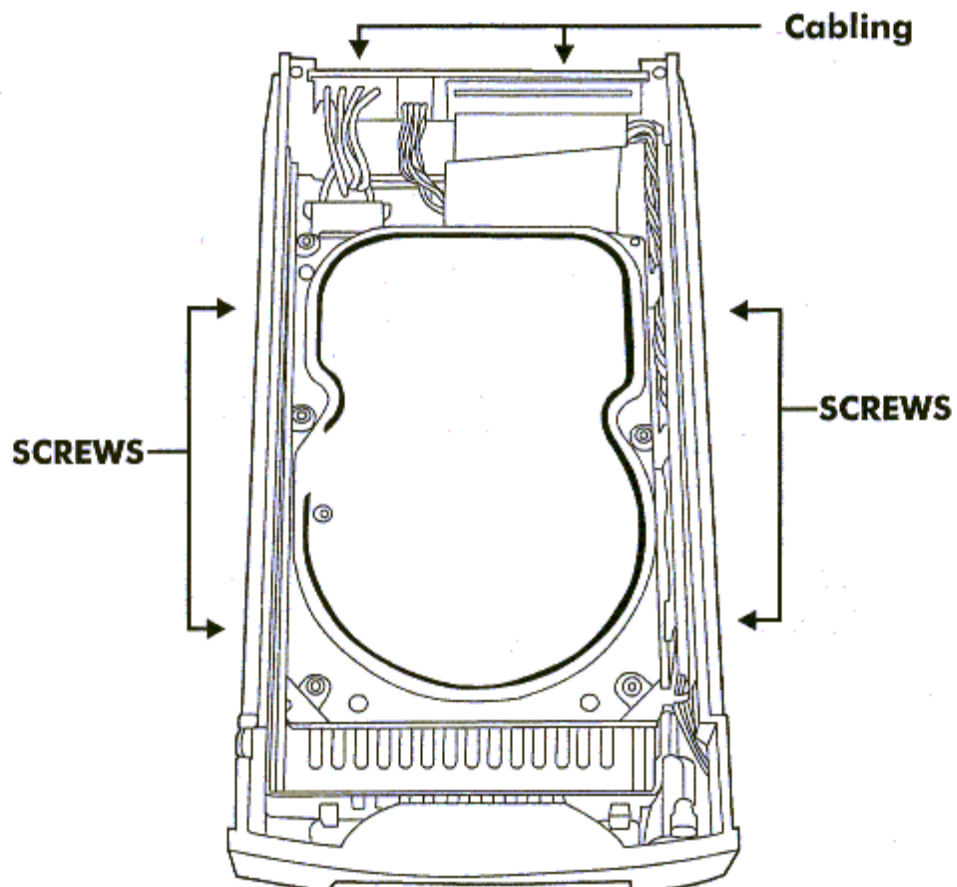

Figure : Installing HDD step 3, 4, 5

Getting Started

Step 6 : Gently slide in the HDD tray.

Step 7 : Lock the HDD tray. When powered on, the Green LED will light up.

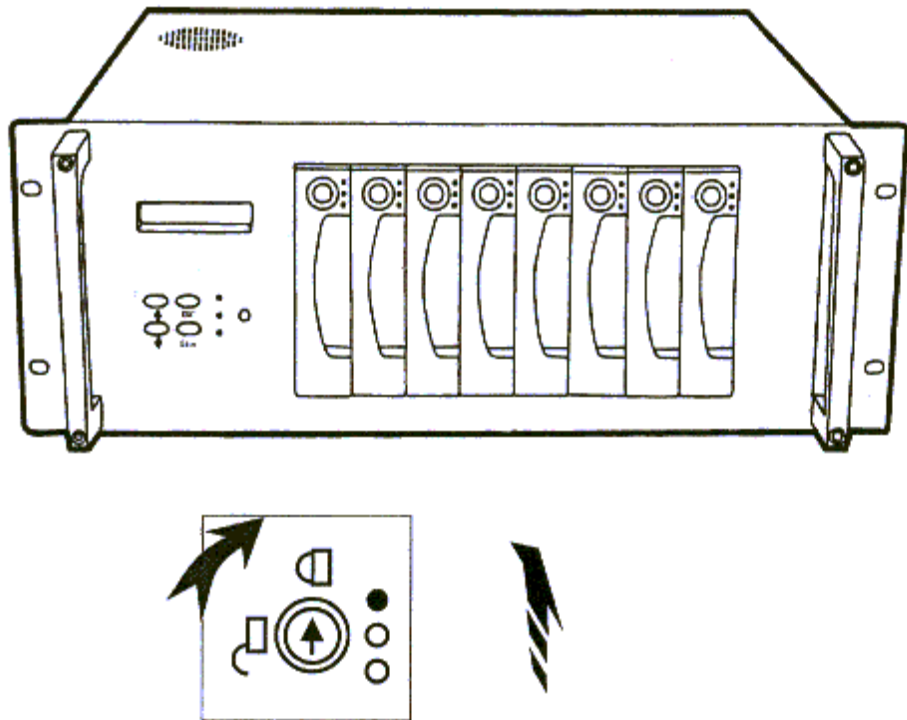

Figure : Installing HDD step 6, 7

Host Linkage

With the HDD(s) installed correctly, you are ready to connect the Disk Array to your Host computer.

Use a shielded twisted-pair SCSI cable to connect your Host computer to the Disk Array's built-in 68 pin SCSI adapter port.

Connect the Host computer as shown below :

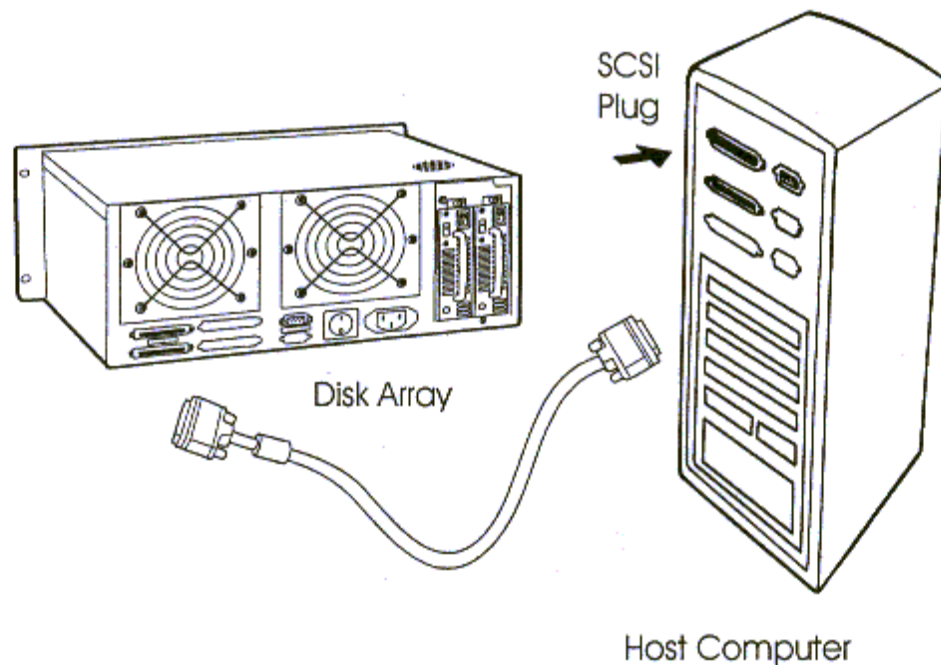

Figure : Host linkage

Caution !

For safety reasons, make sure the Disk Array and Host Computer are turned off when you plug-in the SCSI cable.

Power-On and Self-Test

When you connect the Disk Array to the Host computer, You should press the ON/OFF Power Supply Switch on both of the power supply Hot-Swap units and the Main Switch. It will turn the Disk Array on and the Self-Test will be started automatically.

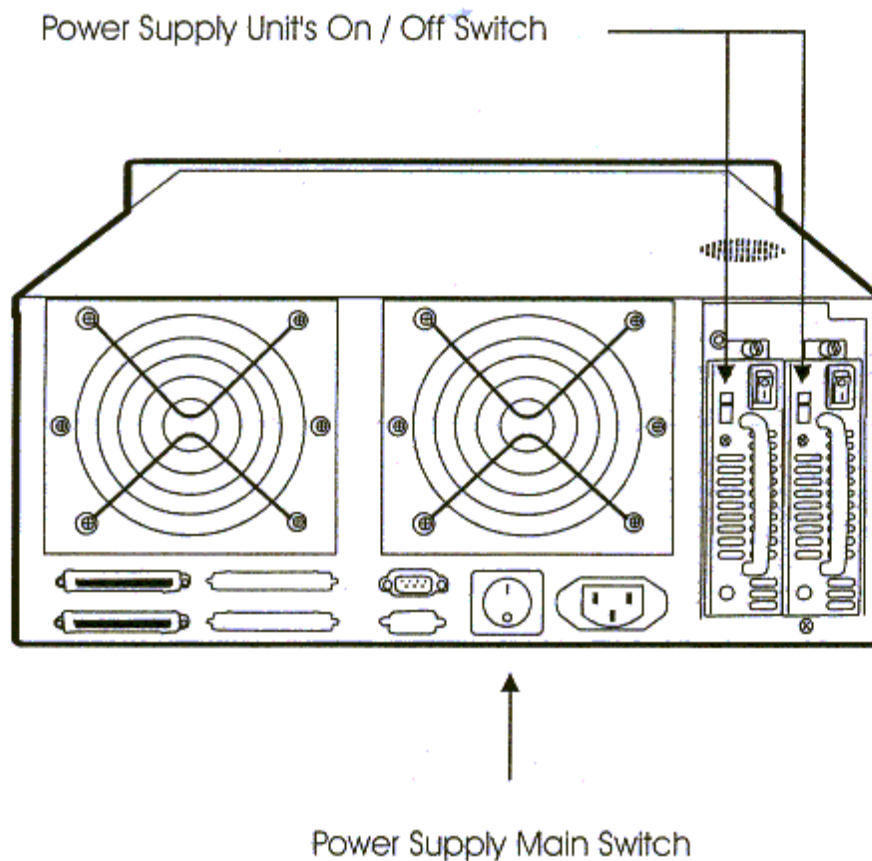

LED Display & Function Keys

LED Display

Shown below is the LED Display. Please refer to the illustration, the LEDs inform you of the Disk Array's current operating status. Upon activating a certain function, the corresponding LED indicator should turn on indicating that the feature is engaged.

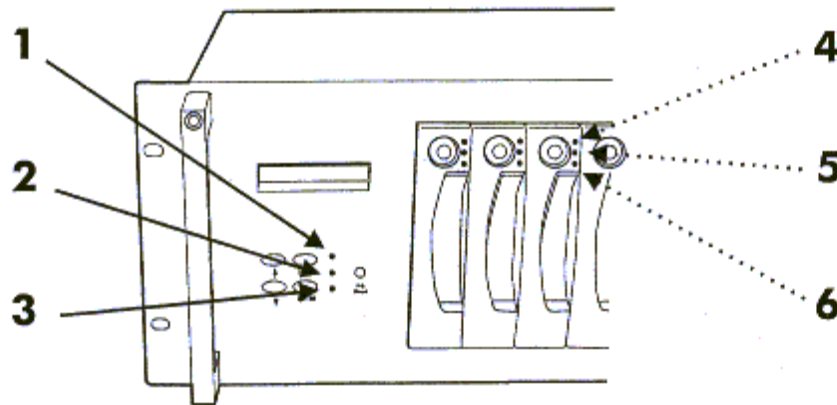

Figure : LED Display

LED	Descriptions
1. Power Unit 1 Indicator	light up : "Green" , it lights when the Power Unit 1 is plugged and operating functionally.
2. Power Unit 2 Indicator	light up : "Green" , it lights when the Power Unit 2 is plugged and operating functionally.
3. Host Computer Access Indicator	light up : "Yellow" , Indicates Host computer is currently accessing the Disk Array
4. HDD Power-On Indicator	light up : "Green" , It lights when the HDD frame is locked and Power-On
5. HDD Access Indicator	light up : "Yellow" , when HDD is accessed
6. HDD Error Indicator	light up : "Red" , when the HDD not installed or error.

Function Keys

The four function keys at the top of the front panel perform the following functions :

(↑) Up Arrow / Right Arrow	Use to scroll the cursor Upward / Rightward
(↓) Down Arrow / Left Arrow	Use to scroll the cursor Downward / Leftward
(Enter)	Use to confirm a selected item
(ESC)	Use to exit a selection

LCD Status Panel

Located the LCD panel, the LCD status panel informs you of the Disk Array's current operating status at a glance. Upon activating a certain function, a symbol or icon corresponding to that function will appear in the display window. The symbol will remain in the display window indicating the status of the Disk Array.

Identifying the status on the LCD

The following illustration shows the symbols (characters) been used and their representation.

A description of each of the symbols in LCD display window :

O	On-line and functional
R	Error occur
I	Identifying Disk Drive
S	Spare Disk Drive
X	Disk Drive not installed

Example of the LCD status display window :

OOOOOSXX R5 ID:0

This informs you :

- a. HDD 1 ~ HDD 5 : Online
- b. HDD 6 : It is a Spare disk drive
- c. HDD 7 ~ HDD 8 : Not installed
- d. RAID Level : In " RAID Level 5 "
- e. SCSI ID : In " ID# 0 "