

Chapter 5 : " Hot Swap "

This chapter explains how to remove and install the "Hot-Swap" parts without interrupting the data access while the disk array is on.

The "Hot-Swap" parts include :

- Hard Disk Drives
- Redundant Power Supply Units
- Cooling Fans

Follow the steps below and refer to the diagrams to remove and install the "Hot-Swap" parts.

Removing / Installing Hard Disk drives

a. Unlock the HDD tray

(When a HDD error occurs, the HDD LED indicator lights up "RED")

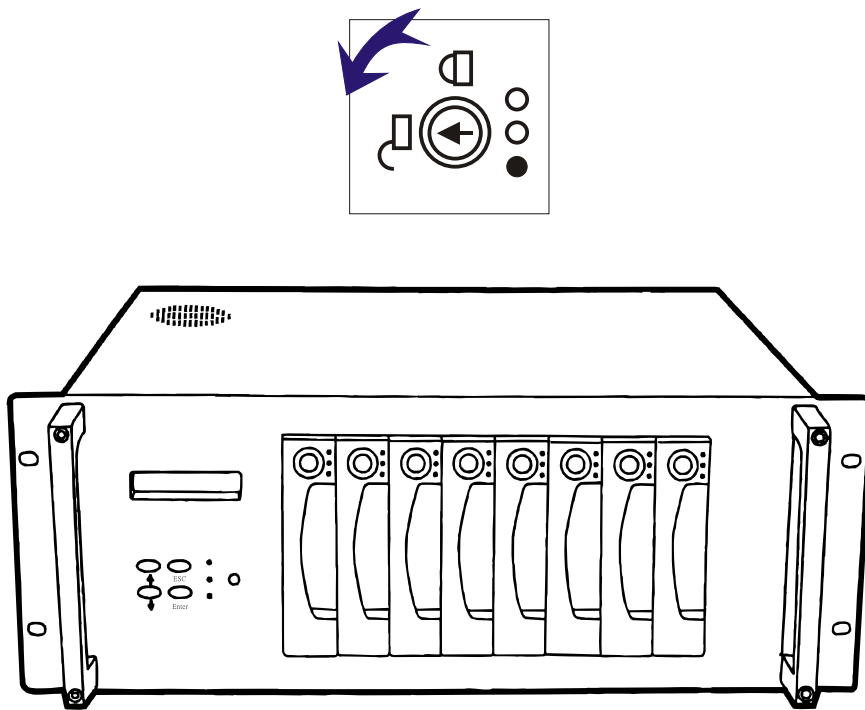

Figure : Swap HDD (Unlock)

b. Gently pull-out the HDD tray

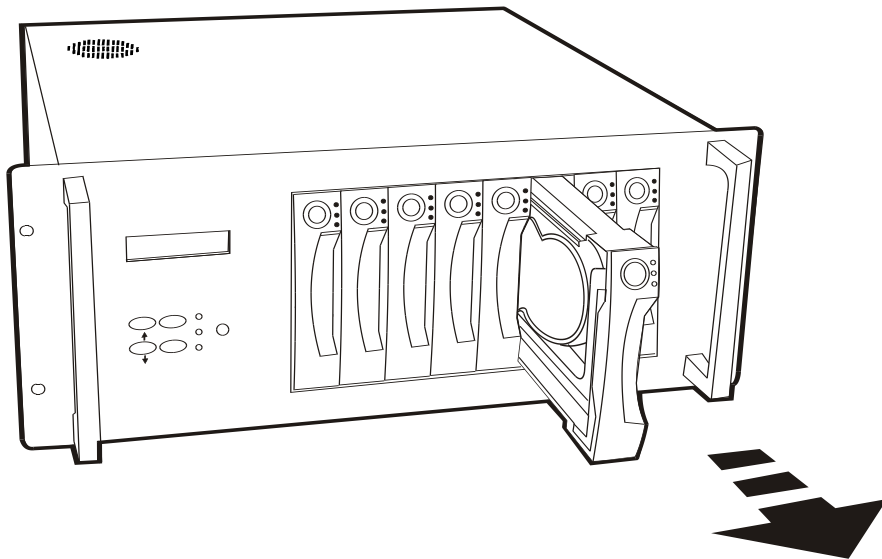

Figure : Swap HDD (Pull-out)

c. Unscrew and unplug the cables

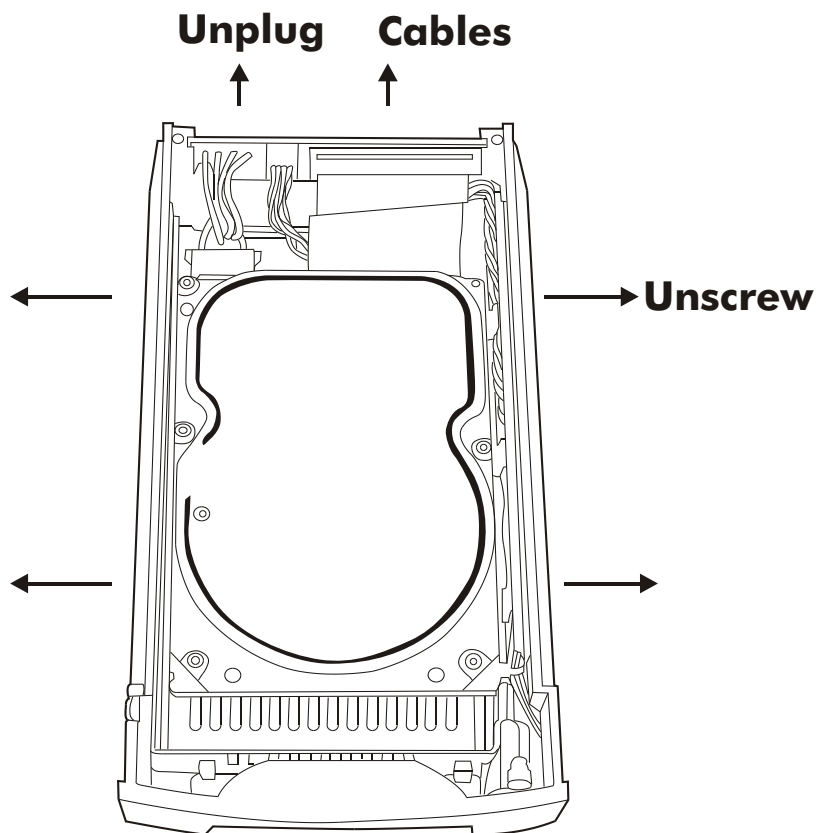

Figure : Swap HDD (Unplug cables)

d. Replace with a new Hard Disk Drive

It must be same capacity or greater than the faulty drive, if you replace with a Hard disk Drive of insufficient capacity, the Disk Array's built-in buzzer will sound and the intelligent Auto-Rebuild function will not be started.

- * For best performance, we recommend you swap with an identical Hard Disk Drive.

e. Gently Slide-in the HDD tray and lock up to start the Auto-Rebuild

When you have installed the replacement disk drive, screw in all the screws and plug in the cables, you may now gently slide in the HDD tray into the chassis and lock up it.

- * Data Auto-Rebuild will be started automatically when you lock up the HDD tray.

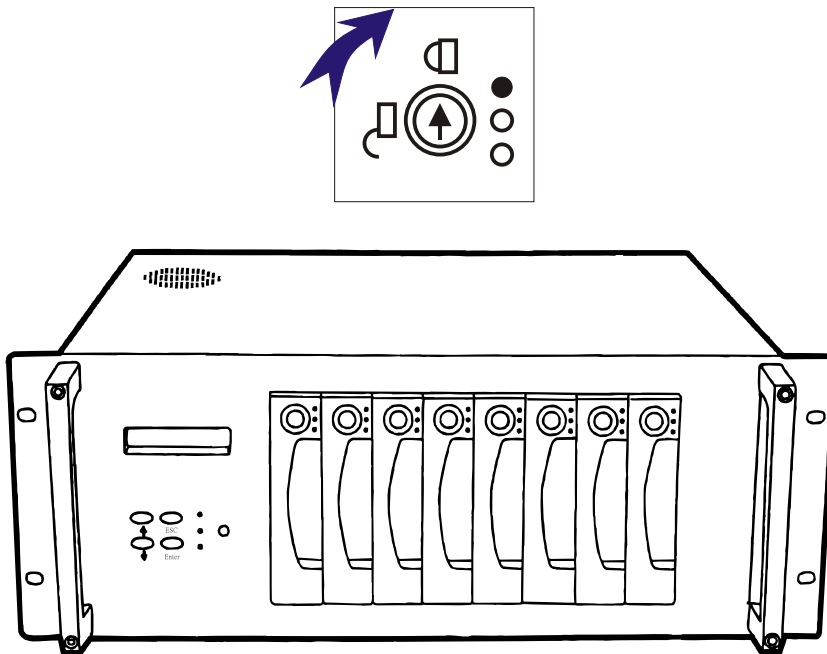

Figure : Swap HDD (Lock Up)

Removing / Installing the Redundant P/S Unit

There are two LED indicators on the front panel which display the status of the redundant power supplies. While the power supply is working properly the two LED indicators light up " Green ", if any one of them fail, the LED indicator will go off and the redundant power supply buzzer alarm will sound.

When you need to replace the redundant power supply unit , refer to the redundant power supply status LED indicator on the front panel to find the failed power supply unit and follow these steps to swap it.

a. Unscrew the faulty unit

(For Safety reasons, you should switch off the faulty unit's power switch)

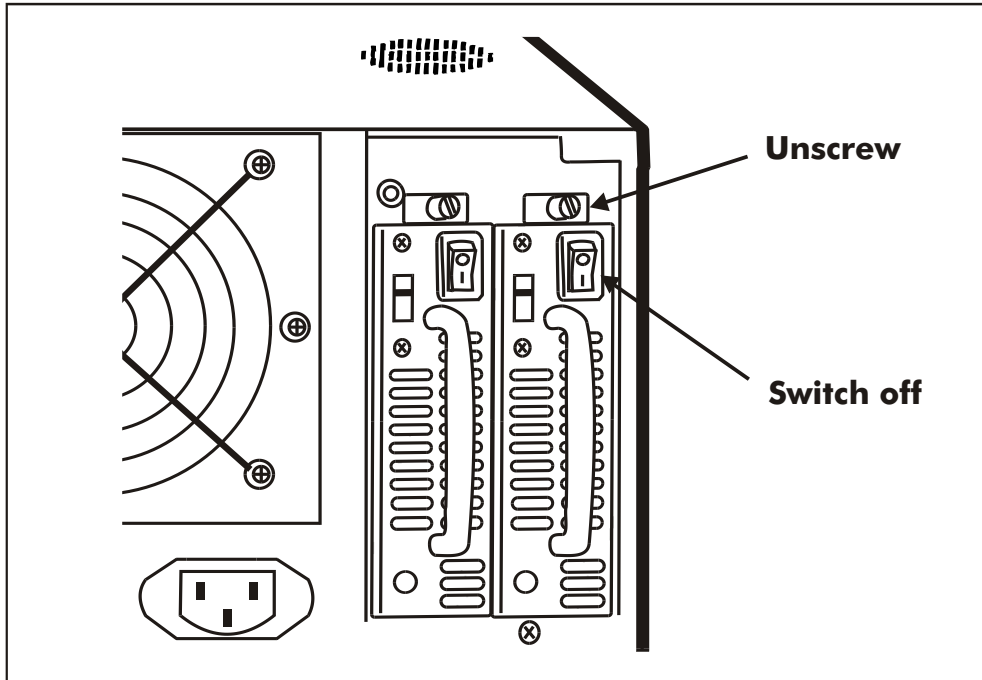

Figure : Swap P/S unit (Unscrew)

b. Replace with a new power supply unit

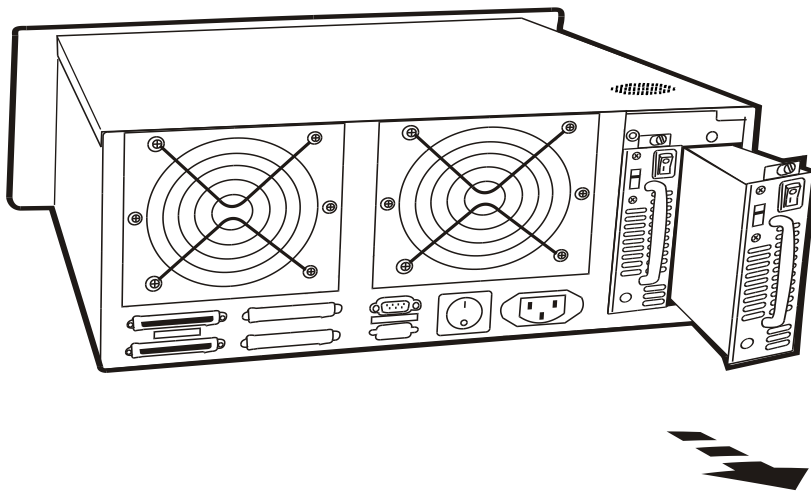

Figure : Swap P/S unit (swap with a new unit)

c. Press the Power Supply Reset switch

When you replace a new power supply unit, you should then push the power supply reset switch on the front panel to stop the buzzer alarm and link the two power supply units together.

- ⦿ The new power supply unit will link with the other unit immediately and will start working after you press the power supply reset switch, and the buzzer warning noise will stop.

- Reset from the front panel

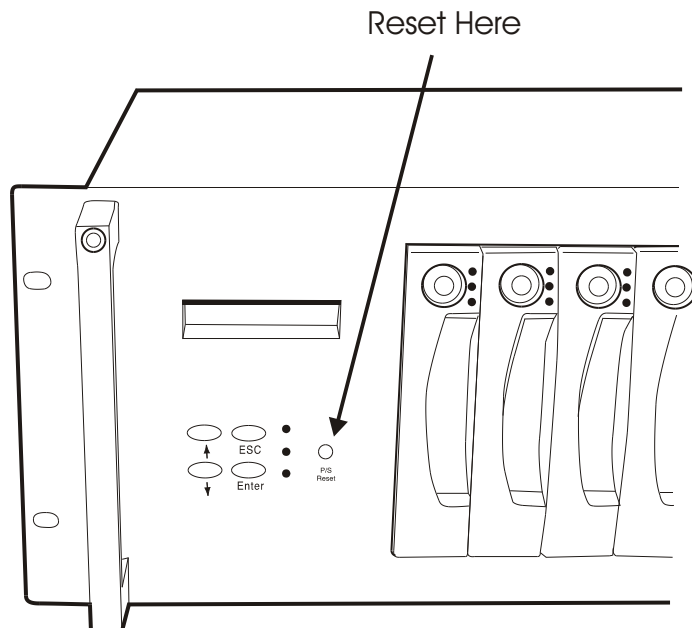

Removing / Installing Cooling Fans

- Unscrew the Fan door and open the door.

! Caution : Be careful , the high speed rotating fans may harm you. Don't touch the rotating Fans, If necessary, Unplug the Fan power connector first.

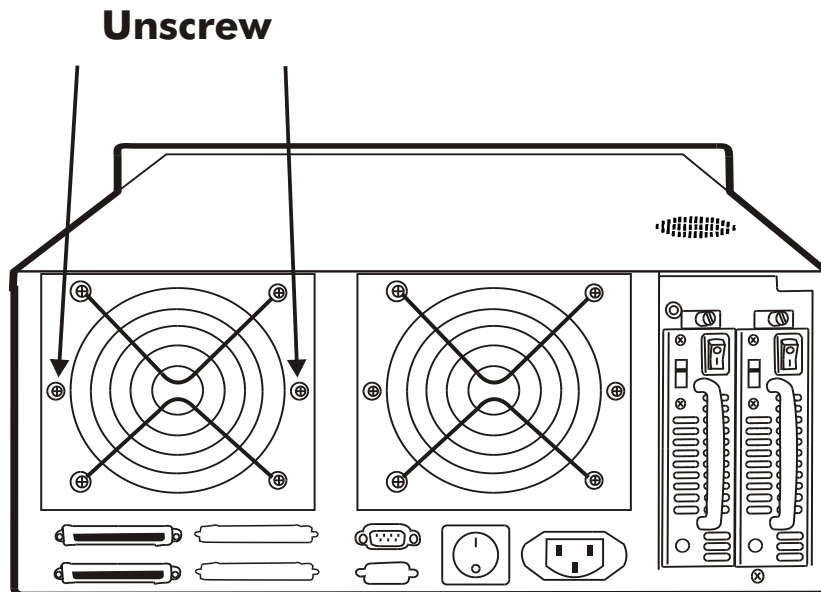

Figure : Swap cooling Fan (Unscrew the Fan Door)

- Unplug the Fan connector
 - Unscrew the faulty cooling fan and replace with a good one
 - ☆ **Important !** The cooling fan's air flow must point to the fan door, please refer to the label on the cooling fan.
 - Plug in the fan connector, close the fan door and screw it in
- ! Caution :** The cooling fan will rotate immediately when you plug in the fan power connector.

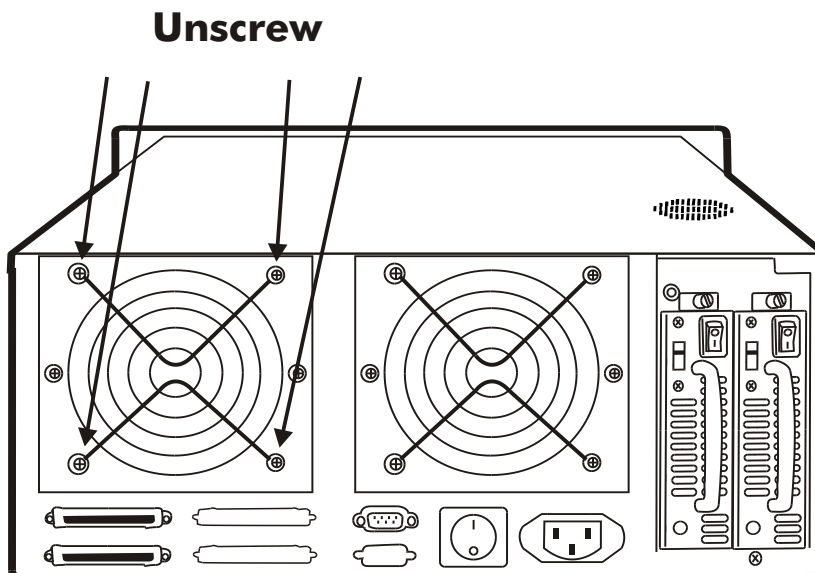

Figure : Swap Cooling Fan (swap with a new Fan)

Technical Specifications

Microprocessor	Intel i80303 (64-bit RISC processor)
Cache Memory	64MB* Maximum 512MB
DRAM Slots	One
Module Type	144 Pin DIMM
DRAM Type	SDRAM
DRAM Speed	PC100/133
RAS access time	
CAS access time	
Parity	Non-Parity
Read Cache	Read-Ahead
Write Cache	Write Back*
Firmware	Flash EEPROM ,256K x 8
SCSI I/O Processor	LSI SYM53C1010
Serial Port	1x RS232 (Asynchronous) Port
Ba ud Rate	115,200 (Bits Per Second)
Da ta Bits	8
Sto p Bit	1
Pari ty	None
RAID Levels	0 , 1 , 0+1, 3 or 5
Data Transfer Rate	Up to 160MB/s (Synchronous)
SCSI ID Assignment	0 ~ 14 (0*)
Tagged-command queuing	Up to 255 simultaneous data requests

Interface :	Host Channel	1* Ultra 160 LVD SCSI (68 pin)
	Disk Channels	8* EIDE ATA-100
Drives		Hot Swap, User Replaceable Up to Eight 3.5" drives (1" height)
Maximum Fault Tolerant Capacity		> 1TB
Drive MTBF		> 1,000,000 hrs
Host Requirement		Host Independent
Operating Systems		O/S Independent and Transparent
Data Rebuild		Automatic Data Regeneration
LCD Display Panel		2 x 16 Characters
Cooling Fans		12cm Ball Bearing Fan 2 Fans
Power Supply Capacity		Dual 300W Independent Power Supplies
AC Input Voltage		115 / 230V (+/-10%) , 60/50 Hz
Environmental		
	Relative Humidity	10% to 85% Non-condensing
	Temperature Operating :	5°C ~ 40°C
	Storage :	-25°C ~ 60°C
Safety testing		UL, CE and FCC Class B
Dimensions		483mm(W) * 445mm(D) * 175mm(H)
Weight		18 kgs (W/O Disk Drive)

" * " Default Settings

*** Various trademarks belong to their respective owners.