

Q

QS216

Thank you for choosing an MB Quart Q series component set for your car audio sound system. With proper installation, you are on the path to experiencing your music in a way you only imagined possible. Here at MB Quart, we call this "Sound In Every Detail."

The Q series has been designed for those unique individuals who settle for nothing but the best! Utilizing MB Quarts' proprietary acoustic technologies and over 30 years of experience developing and manufacturing speaker systems, the Q series makes the emotions of music so perceptible that the passion of the musician is in perfect harmony with the listener's feelings.





QS216

Side View Of QM216

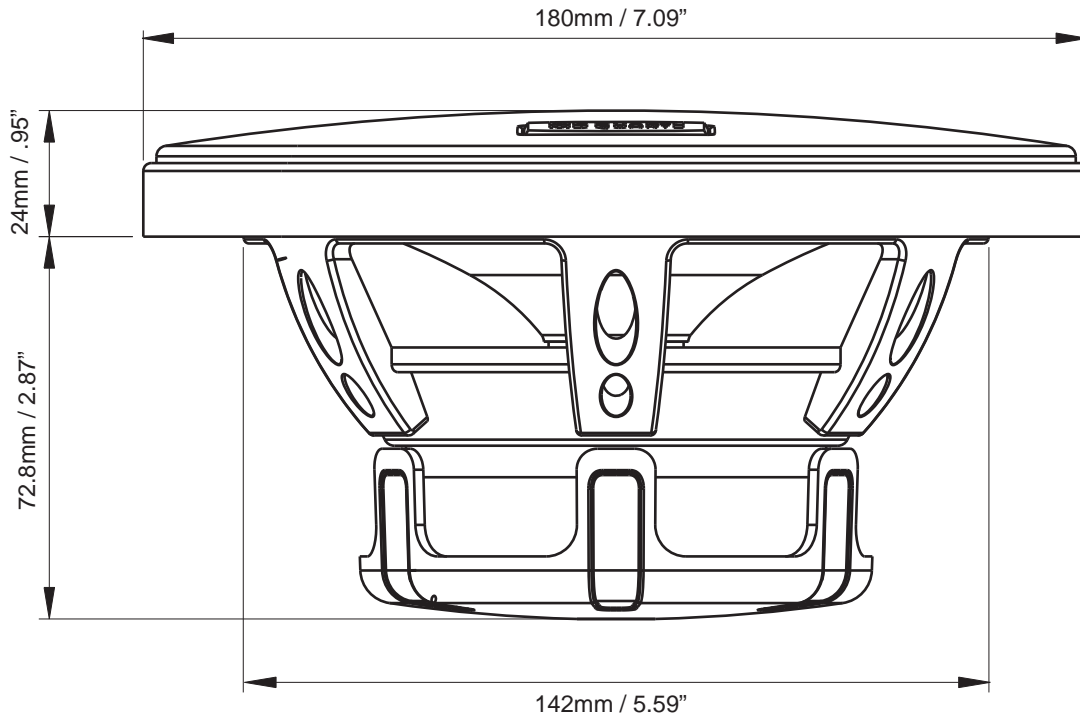

Side View Of QTW216

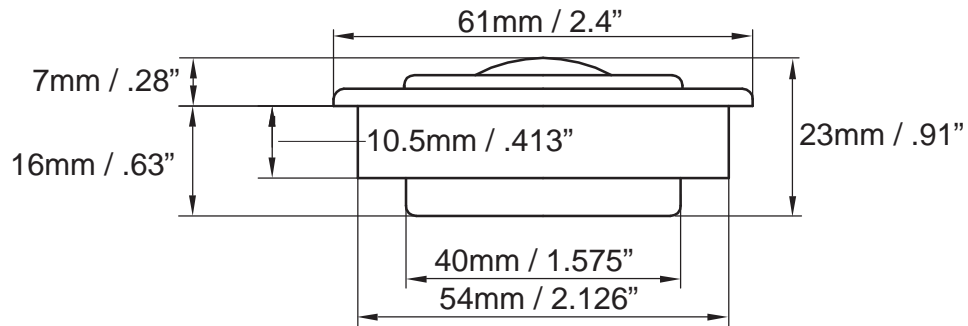

Top View Of QXO216

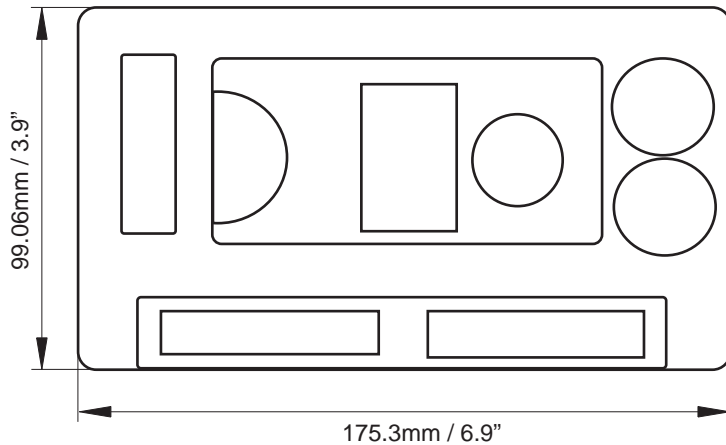

Side View Of QXO216

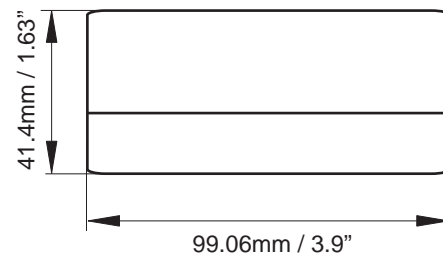



QS216

MBQUART
German Engineering

QXO216 Crossover:

- Bi-Amplifiable: Tweeters can be powered separate from Midrange by removing jumpers and providing power from independent channels.
- Tweeter Attenuation: Adjusts audible output of tweeter. Selectable settings of +1dB, 0 dB, -2dB and -4dB.
- Midrange Attenuation: Adjusts audible output of midrange. Selectable settings of 0dB, -3dB and -5dB.

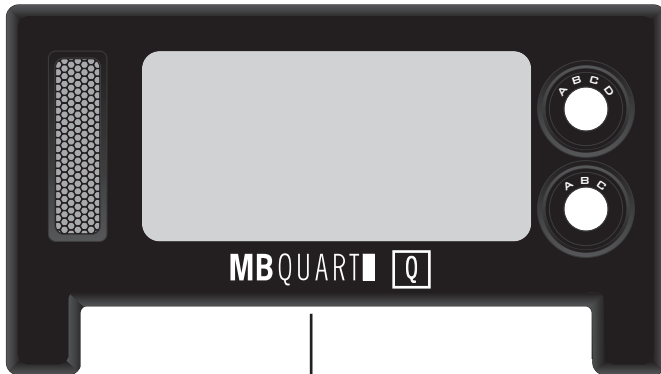

Removable Top

Jumpers:  x 2 per crossover

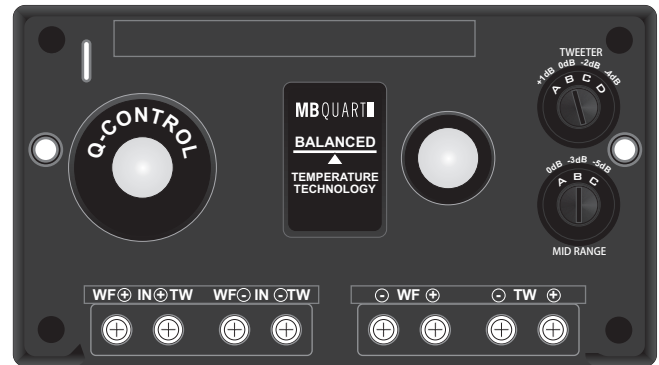

Input From Amp

WF: Output to Midrange
TW: Output to Tweeter

QS216 SPECIFICATIONS

Woofers: 6.5" Nomex PMI Composite material designed to be both light in weight and rigid. This combination allows for a flat linear response and incredible low frequency reproduction with high sensitivity.

Tweeters: 40mm Teteron Silk Composite material that allows for flawless reproduction of frequencies found in silk tweeters and improved durability from the Teteron blend.

Crossover

Networks: The High Definition Crossovers offer advanced "Q Control" for the tweeter and midrange with variable points of attenuation. Featuring MB Quarts' Balanced Temperature Control Technology, your music will never suffer through lengthy periods of high power listening.

Continuous Power Handling: 80 watts

Maxx Music Power: 170 watts

Frequency Response: 35Hz - 32,000Hz

Efficiency Q 1W/1M: 89 dB

Nominal Impedance: 4 Ohms

Included Components and Parts:

- Two QM216 6.5" (160mm) Woofers
- Two QTW216 1.575" (40mm) Tweeters
- Two QXO216 Crossover Networks
- Two Flush Mount Tweeter Fixtures
- Two Angle Mount Tweeter Fixtures
- Two Mesh Tweeter Grills
- Two Mesh Woofer Grills
- Two ABS Grill Trays
- Bag A:
 - 8 pcs M4x32 Black Screws For Speakers
 - 8 pcs Clips For Speakers
 - 4 pcs M4x12 Black Screws For Crossover
- Bag B:
 - 8 pcs Clips For Tweeters
- Bag C:
 - 6 pcs Nickel Plated Screws For Tweeters
 - 2 pcs Nickel Plated Flat Washers For Tweeters
 - 2 pcs Nickel Plated Spring Washers For Tweeters



QS216

We strongly recommend that you have your new Q series speakers installed by your authorized MB Quart dealer. The installation professionals employed by your dealer have the necessary tools and experience to disassemble your vehicle, install your new speakers and reassemble everything properly. If you prefer to perform your own installation, it is very important that you read the entire manual first.

GETTING STARTED:

- Turn off the audio system.
- Check clearance on both sides of mounting surface to ensure that there are no obstructions (windows, tracks, wiring etc).

CROSSOVER NETWORK INSTALLATION:

- Locate a dry location for mounting of your Q Crossover Networks. **DO NOT MOUNT IN DOORS!**
- Remove the cover of the crossover by squeezing either side. This exposes the mounting holes for securing the crossover to a flat surface. *Prior to pre-drilling pilot holes, ensure that you will not be drilling into wiring, gas tanks, fuel lines etc.*
- Once the crossover is mounted, snap the protective cover back in place.

WIRING DIAGRAMS FOR STANDARD WIRING AND BI-AMP WIRING

Standard Wiring Configuration: This wiring configuration is used when you want to power each crossover with a single amplifier channel. **It is important that you leave the jumper pins in the locations shown in the diagram labeled Standard.**

Bi-Amp Wiring Configuration: This wiring configuration is used when you want to power each crossover with a pair of amplifiers (Bi-Amp) or pair of channels (Bi-Wire). In this mode, the inputs to the woofer's low-pass filter and the tweeter's high-pass filter are electrically isolated. This configuration is shown in the diagram labeled **Bi-Amp.**

STANDARD

Crossover #1:

1. Connect Amplifier Channel 1 + to Crossover **WF + IN.**
2. Connect Amplifier Channel 1 - to Crossover **WF - IN.**
3. Connect Crossover **WF +** and - output to the corresponding + and - on midrange speaker #1.
4. Connect the Red tweeter wire to the output **TW +** on the Crossover.
5. Connect the Black tweeter wire to the output **TW -** on the Crossover.

Crossover #2:

1. Connect Amplifier Channel 2 + to Crossover **WF + IN.**
2. Connect Amplifier Channel 2 - to Crossover **WF - IN.**
3. Connect Crossover **WF +** and - output to the corresponding + and - on midrange speaker #2.
4. Connect the Red tweeter wire to the output **TW +** on the Crossover.
5. Connect the Black tweeter wire to the output **TW -** on the Crossover.

Bi-Amp

Crossover #1:

1. Connect Amplifier Channel 1 + to Crossover **WF + IN.**
2. Connect Amplifier Channel 1 - to Crossover **WF - IN.**
3. Connect Crossover **WF +** and - output to the corresponding + and - on midrange speaker #1.
4. Connect Amplifier Channel 3 + to Crossover **TW + IN.**
5. Connect Amplifier Channel 3 - to Crossover **TW - IN.**
4. Connect the Red tweeter wire to the output **TW +** on the Crossover.
5. Connect the Black tweeter wire to the output **TW -** on the Crossover.

Crossover #2:

1. Connect Amplifier Channel 2 + to Crossover **WF + IN.**
2. Connect Amplifier Channel 2 - to Crossover **WF - IN.**
3. Connect Crossover **WF +** and - output to the corresponding + and - on midrange speaker #2.
4. Connect Amplifier Channel 4 + to Crossover **TW + IN.**
5. Connect Amplifier Channel 4 - to Crossover **TW - IN.**
4. Connect the Red tweeter wire to the output **TW +** on the Crossover.
5. Connect the Black tweeter wire to the output **TW -** on the Crossover.



QS216

MBQUART
German Engineering

Standard Wiring Diagram

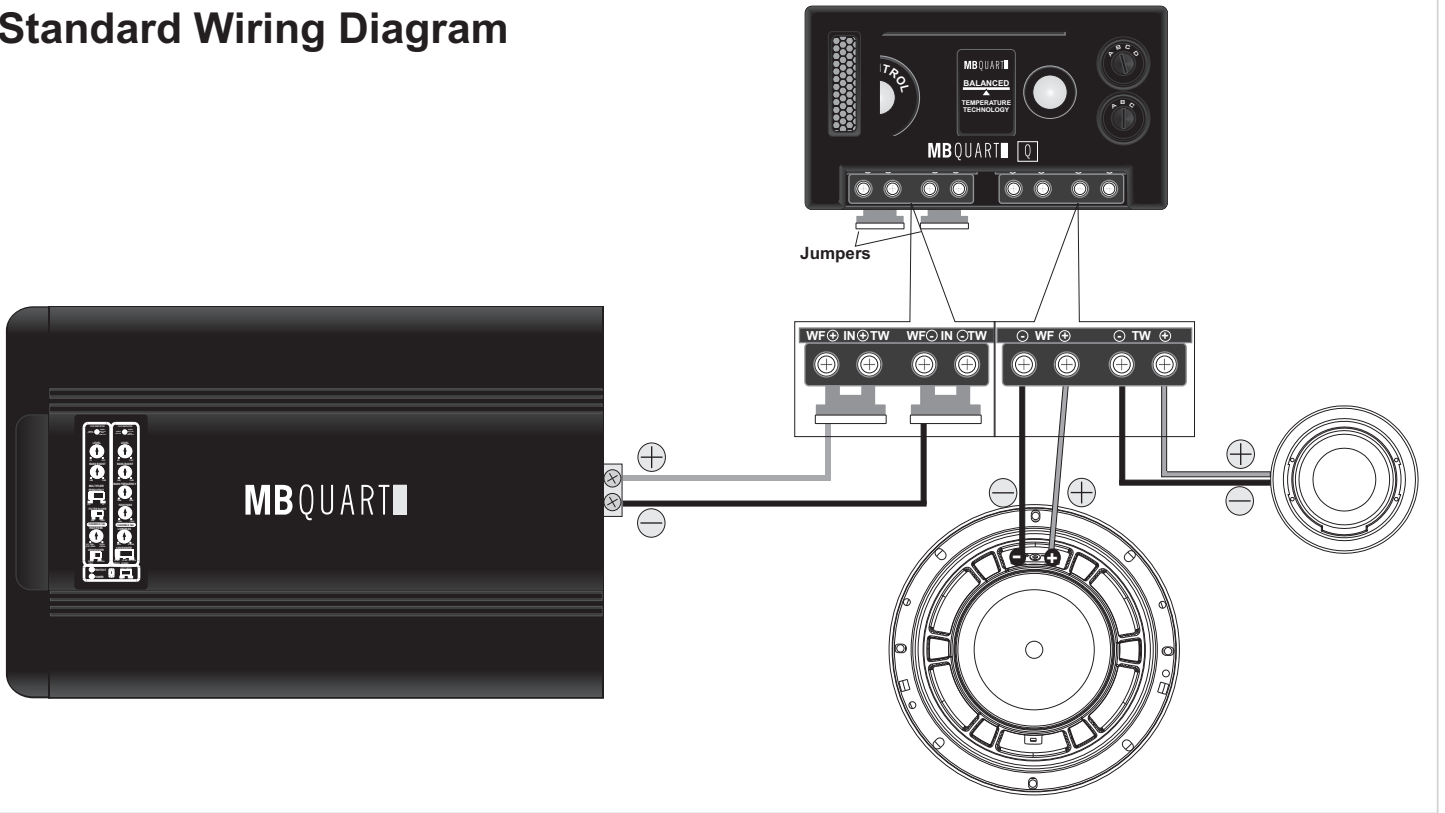

Bi-Amp Wiring Diagram

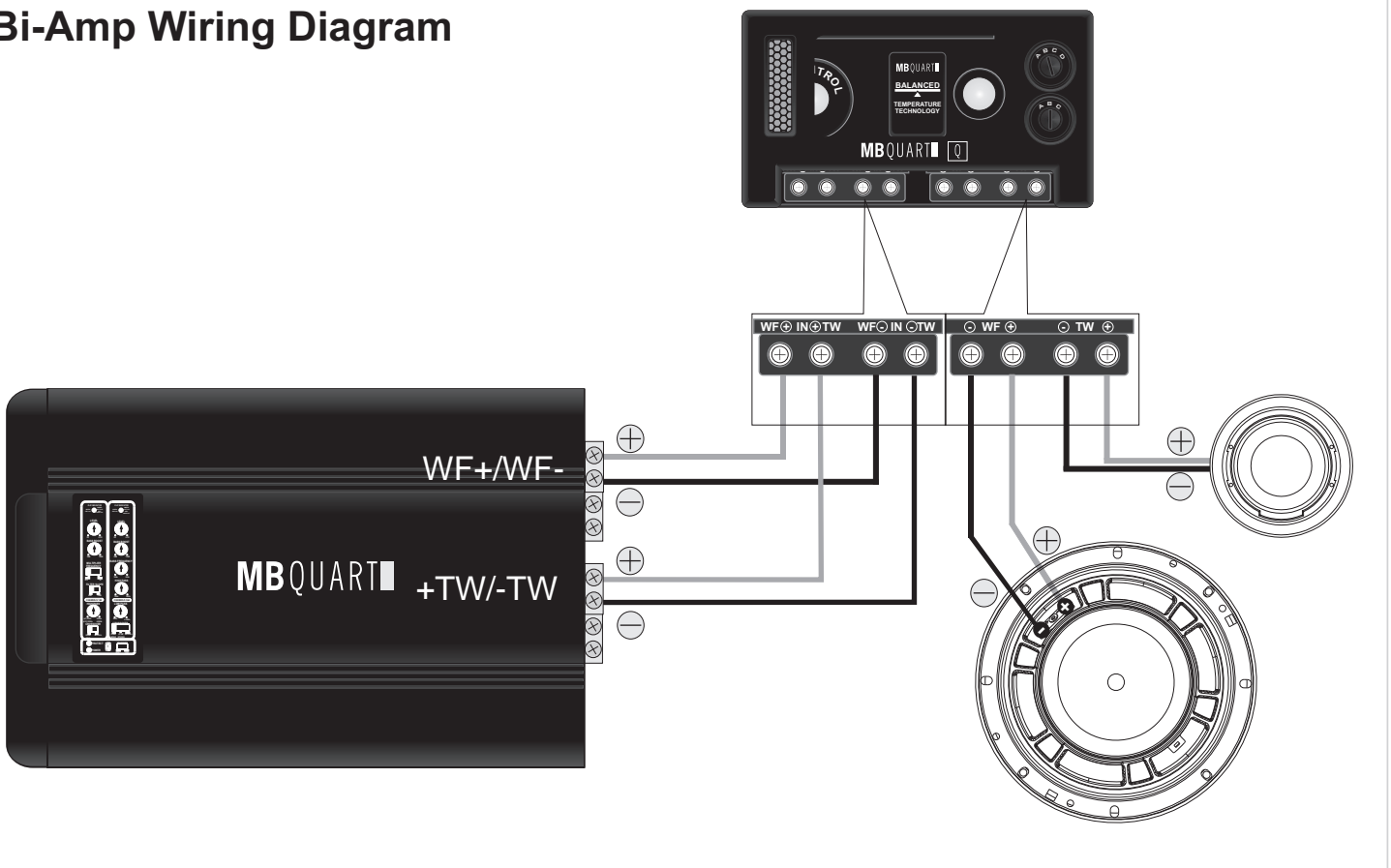



QS216

Tweeter Mounting Options

Flush Mount Method

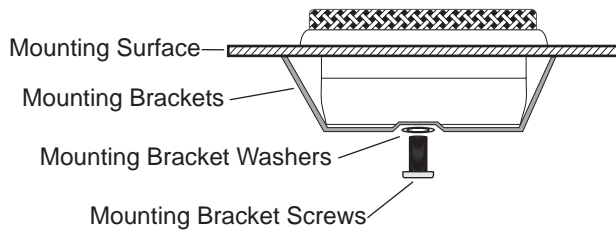

Top Mounted Method

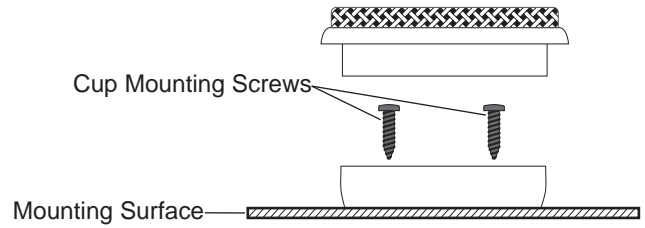

Surface Angle Mount Method

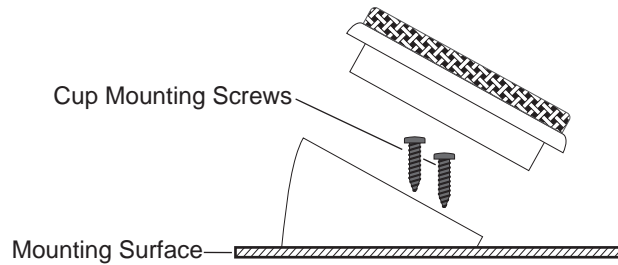

Woofer Mounting Options

Mounting With ABS Gasket And Grill

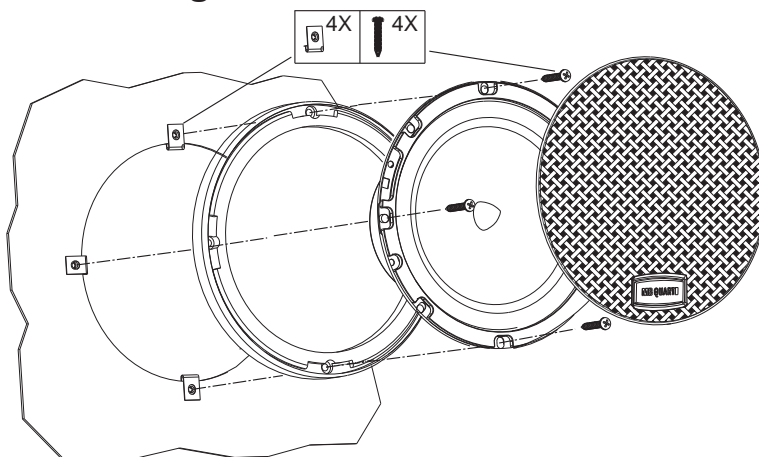

Mounting Without Grill

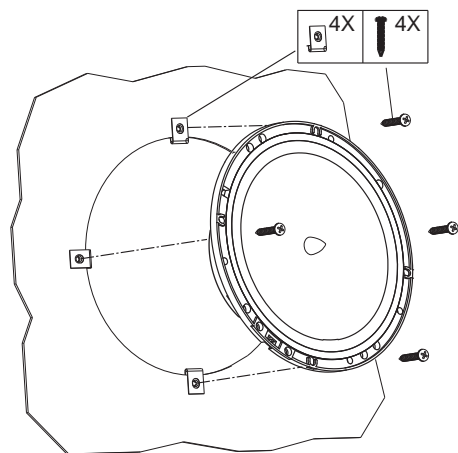

Speaker, Tweeter and Crossover Placement Options:

Factory sound systems vary greatly. Some systems have coaxials (tweeter fixed in the center of the midrange) in the door, while others have factory component (tweeter is separate from midrange) systems. If your system has the factory component offering then you will want to locate your factory tweeter mounting location and compare it to the diagram below. Some vehicles already have the tweeter in the ideal location, while others often position the tweeter in the top corner of the door pane which is less than ideal. A good rule of thumb is to try and mount the tweeter within 8 inches of the midrange woofer for optimal imaging and tonal balance. When selecting an optimal mounting location, ensure that you are clear of any obstructions within the door. Cutting or drilling into moving parts or electrical accessory wires can be very dangerous and costly.

Woofers should typically be installed in the factory locations. Simply ensure that the new woofer will not obstruct the window or other moving parts in the door.

The Crossover should **NEVER** be mounted in the shell of the door. This can damage the crossover through vibration and moisture which is **NOT** covered under warranty. The Crossover can be mounted in a kick panel, under a seat or in the trunk as long as the area is not located near any moving parts in the vehicle which could cut or pull the wires resulting in a short circuit.

All wiring to and from the crossover should avoid all moving parts in the vehicle which could potentially damage the wiring. Take great care when running wires through the door frame and into the door as wires can easily be cut. A rubber grommet should be used on both holes and wire loom should be wrapped around the exposed wires as shown in the diagram below.

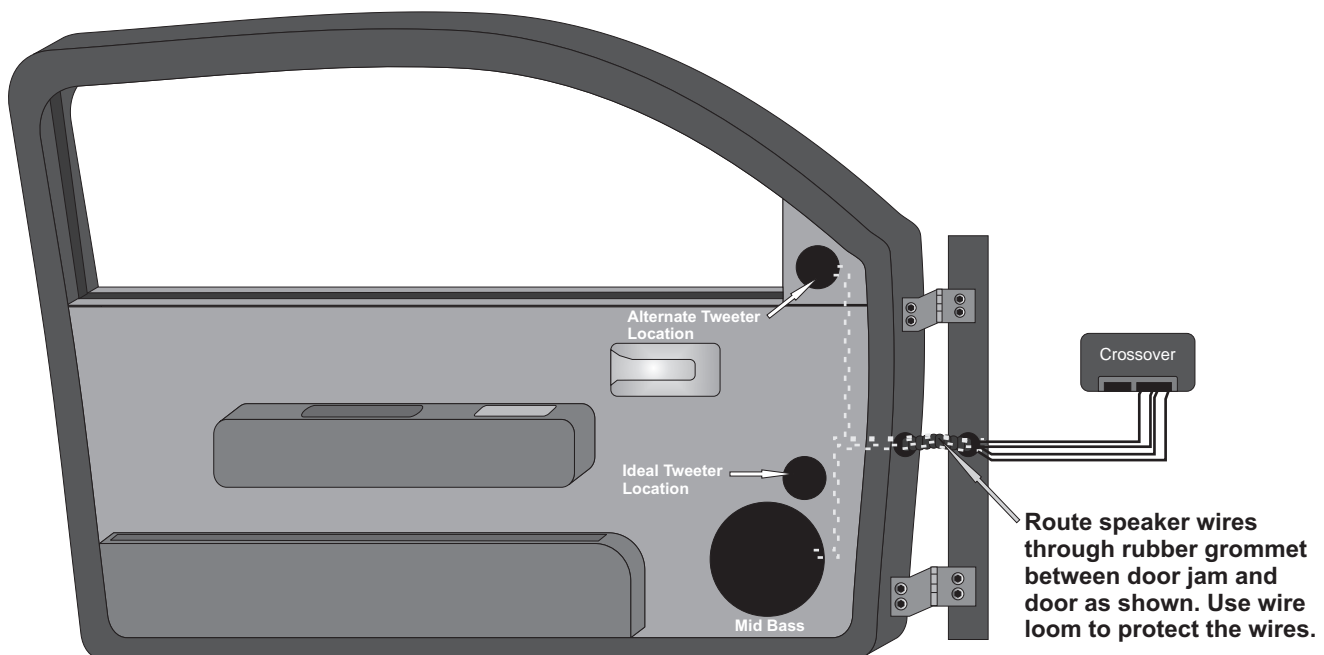

MBQUART

German Engineering

MAXXSONICS USA, INC.
1290 Ensell Road
Lake Zurich, Illinois 60047 USA
E-Mail info@maxxsonics.com
Website www.maxxsonics.com
www.mbquart.com



Q

QS216

WARRANTY

As the manufacturer of MB QUART car audio products, Maxxsonics USA Inc. warrants to the original consumer purchaser of the product to be free from defects in material and workmanship for one(1) year from the date of purchase.

This product meets the current EU minimum warranty requirements, if purchased in countries of the EU.

To ensure your warranty policy, keep your original receipt proving date of purchase.

All other parts and accessories sold with this product are warranted to be free from defects in materials and workmanship for one(1) year from the date of purchase. Maxxsonics will repair or replace at it's option and free of charge during the warranty period, any system component that proves defective in materials and workmanship under normal installation, use and service provided that the product is returned to the authorized MB QUART dealer from where it was purchased.

A photo copy of the original receipt must accompany the product being returned. In the absence of the above, the warranty is one(1) year from the date of manufacture.

There is no warranty for Unauthorized Internet Sales.

Any damage to the product as a result of misuse, abuse, accident, incorrect wiring, improper installation, alteration of the date code or bar code labels, revolution, natural disaster, or any sneaky stuff because someone messed up, repair or alteration outside of our factory or Authorized Service Centers and anything else you have done that you should not have done is NOT covered.

This warranty is limited to defective parts and specifically excludes any incidental damages connected therewith. This warranty is not construed as an insurance policy.

Warranty on installation labor, removal, re-installation and freight charges are not the responsibility of Maxxsonics USA Inc.

Please keep your purchasing slip for warranty reasons.
Bitte bewahren Sie Ihren Kaufbeleg für Garantiezwecke auf.
Veillez conserver le reçu de caisse pour la garantie.
Por favor conserve su comprobante de compra a efectos de garantía.
Conservate la ricevuta di acquisto ai fini della garanzia.
Сохраните, пожалуйста чек для случаев, требующих предоставления гарантии.

Warranty
Garantie
Garantie
Garantía
Garanzia
Срок Гарантии

1

years
Jahre
ans
años
anni
года



MAXXSONICS®
MBQUART® AUTOTEK®
HIFONICS® CRUNCH®