

# Instruction Manual

Telestar 60AZ-A

60mm (2.4") Altazimuth Refracting Telescope





## WARNING:

**NEVER USE A TELESTAR 60AZ-A TELESCOPE TO LOOK AT THE SUN!** LOOKING AT OR NEAR THE SUN WILL CAUSE INSTANT AND IRREVERSIBLE DAMAGE TO YOUR EYE. EYE DAMAGE IS OFTEN PAINLESS, SO THERE IS NO WARNING TO THE OBSERVER THAT DAMAGE HAS OCCURRED UNTIL IT IS TOO LATE. DO NOT POINT THE TELESCOPE OR ITS VIEWFINDER AT OR NEAR THE SUN. DO NOT LOOK THROUGH THE TELESCOPE OR ITS VIEWFINDER AS IT IS MOVING. CHILDREN SHOULD ALWAYS HAVE ADULT SUPERVISION WHILE OBSERVING.



## MEADE LIMITED WARRANTY

Every Telestar telescope, spotting scope, and telescope accessory is warranted by Meade Instruments Corporation ("Meade") to be free of defects in materials and workmanship for a period of ONE YEAR from the date of original purchase in the U.S.A. Meade will repair or replace a product, or part thereof, found by Meade to be defective, provided the defective part is returned to Meade, freight-prepaid, with proof of purchase. This warranty applies to the original purchaser only and is non-transferable. Meade products purchased outside North America are not included in this warranty, but are covered under separate warranties issued by Meade international distributors.

**RGA Number Required:** Prior to the return of any product or part, a Return Goods Authorization (RGA) number **must** be obtained from Meade by writing, or by calling (949) 451-1450. Each returned part or product must include a written statement detailing the nature of the claimed defect, as well as the owner's name, address, and phone number.

This warranty is not valid in cases where the product has been abused or mishandled, where unauthorized repairs have been attempted or performed, or where depreciation of the product is due to normal wear-and-tear. Meade specifically disclaims special, indirect, or consequential damages or lost profit which may result from a breach of this warranty. Any implied warranties which cannot be disclaimed are hereby limited to a term of one year from the date of original retail purchase.

This warranty gives you specific rights. You may have other rights which vary from state to state.

Meade reserves the right to change product specifications or to discontinue products without notice.

This warranty supersedes all previous Meade product warranties.



## TABLE OF CONTENTS

Introduction .....	.5
Standard Equipment .....	.5
Unpacking and Assembly .....	.5
Altazimuth Mount Movements and Lock .....	.5
Viewfinder Focusing and Alignment .....	.6
Using the Telescope .....	.6
Calculating Power .....	.7
Maintenance .....	.8
A Few Words About Power .....	.8
Specifications .....	.8
Optional Accessories .....	.8

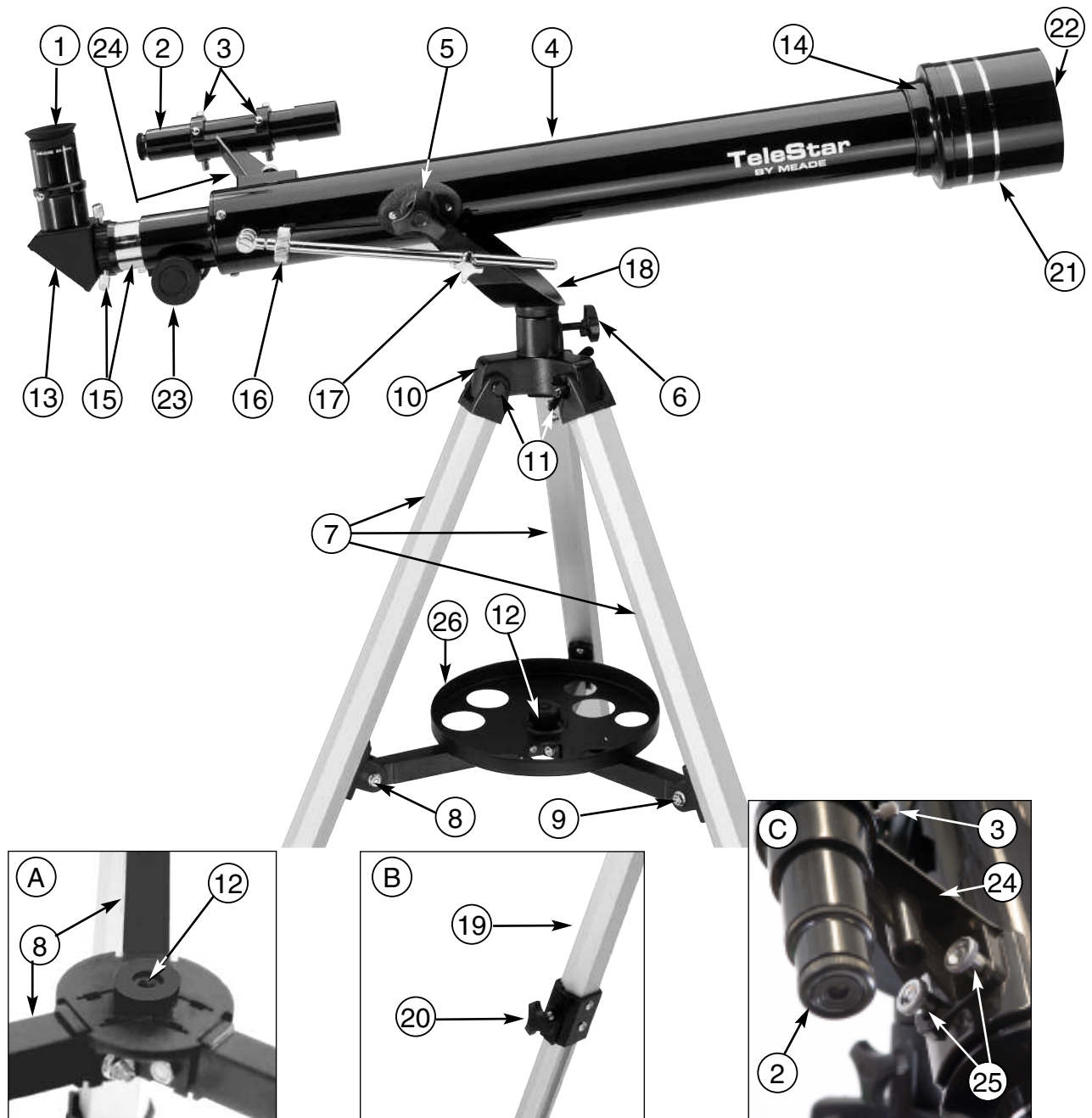

**Figure 1: Telestar 60AZ-A Altazimuth Refracting Telescope**

**Inset A: Accessory Tray Mounting Bolt Hole; Inset B: Tripod Leg; Inset C: Viewfinder Assembly**

- |   |  |
|---|--|
| 1. Eyepiece   | 14. Objective lens cell                              |
| 2. Viewfinder   | 15. Focuser drawtube and thumbscrews                 |
| 3. Viewfinder collimation screws                            | 16. Altitude rod slow motion fine adjustment control |
| 4. Optical tube assembly                                    | 17. Altitude rod coarse adjustment knob control      |
| 5. Vertical lock knobs                                      | 18. Altazimuth mount                                 |
| 6. Horizontal lock knob                                     | 19. Adjustable sliding center leg extension          |
| 7. Tripod legs  | 20. Tripod leg lock thumbscrew (see <b>inset B</b> ) |
| 8. Leg brace supports                                       | 21. Dew shield/lens shade                            |
| 9. Leg brace  | 22. Front lens cap                                   |
| 10. Mount base attachment                                   | 23. Focusing knob                                    |
| 11. Tripod attachment bolts and wing nuts                   | 24. Viewfinder bracket (see <b>inset C</b> )         |
| 12. Accessory tray mounting bolt hole (see <b>inset A</b> ) | 25. Viewfinder bracket mounting thumbscrews          |
| 13. Diagonal mirror   | 26. Accessory tray                                   |

## INTRODUCTION

Before you begin, we urge you to take a few minutes to completely read this manual so that you can get the best use of the equipment. This manual details the set-up, operation, specifications and optional accessories of the Telesstar 60-AZ-A altazimuth refracting telescope. Designed for both astronomical and terrestrial observing, the Telesstar 60-AZ-A will be your companion in exploring a universe of celestial and earthly objects.

## STANDARD EQUIPMENT (Refer to Fig. 1)

- Complete optical tube assembly (objective lens diameter = 60mm; focal length = 700mm)
- Full-length, fully adjustable, aluminum tripod and accessory tray.
- MA25mm (28X), MH9mm eyepieces (1.25" O.D. "Outside Diameter")
- 2x Barlow Lens (1.25" O.D.)
- Diagonal mirror (1.25" O.D.)
- 5 x 24mm viewfinder with bracket
- Altazimuth mount with micro-altitude control
- Hardware package: A. 3 bolts (2" long) with wing nuts and washers  
B. 3 screws (1/2" long) with nuts

**Note:** All other necessary hardware provided in place.

## UNPACKING AND ASSEMBLY

You will need a Phillips-head screwdriver to assemble the tripod.

1. Remove and identify the telescope's components, using the listing above.
2. Attach the 3 aluminum tripod legs (7, Fig. 1) to the base of the altazimuth mount (10, Fig. 1) with the 3 leg brace supports (8, Fig. 1) facing inward. Line up the holes of the tripod legs (11, Fig. 1) with the holes on the mount base attachment and thread the three included bolts through the holes. Thread the wing nuts over the bolts and hand-tighten to a firm feel. Stand the telescope upright and spread the tripod legs evenly apart so that the accessory tray can be positioned for attachment to the leg braces.
3. To attach the leg braces to the tripod, line up the holes in the leg braces (9, Fig. 1) with the holes in the leg brace supports (8, Fig. 1) and slide the the included 1/2" screws through the holes. Thread the included nuts over the end of the bolts and hand-tighten to a firm feel.
4. To attach the accessory tray (26, Fig. 1) to the leg braces (9, Fig. 1), place the round accessory tray over the over mounting bolt hole (12, Fig. 1). Thread the attachment knob into the mounting hole on top of the tray and turning the knob clockwise. Tighten to a firm feel, but do not overtighten—you need to remove the tray if you wish to collapse the tripod. To remove the tray, just rotate the knob counterclockwise and remove the knob. You can then lift and remove the tray.
5. Extend the sliding center portion of the adjustable height tripod leg (19, Fig. 1) to the desired length for all 3 legs. Lock the tripod legs by tightening the leg lock thumbscrew (20, Fig. 1) to a firm feel. See **Inset B**.
6. Remove the two vertical lock knobs (D, Fig. 2) from the optical tube assembly.
7. Place the optical tube between the forks of the azimuth mount (A, Fig. 2), oriented as shown in Fig. 2.
8. Slide the altitude rod (B, Fig. 2) into the hole in the altitude coarse adjustment control assembly (C, Fig. 2). Tighten to a firm feel.
9. Thread a vertical lock knob (D, Fig. 2) through each of the holes in the forks of the azimuth mount (A, Fig. 2) and tighten to a firm feel.
10. Attach the viewfinder bracket (2, Fig. 1) to the telescope using the 2 thumbscrews provided (25, Fig. 1). The thumbscrews fit through the 2 holes located at the base of the viewfinder bracket and thread into the main tube (see Fig. 1, Inset C).

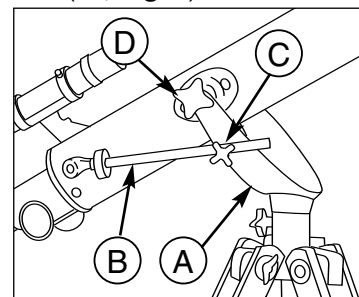

**Fig. 2 Mounting the optical tube assembly:** (A) azimuth mount; (B) altitude rod; (C) altitude coarse adjustment control; (D) vertical lock knob.

11. Insert the diagonal mirror (**13, Fig. 1**) into the focuser drawtube (**15, Fig. 1**) and the MA 25mm eyepiece (**1, Fig. 1**) into the diagonal mirror. Tighten the respective thumbscrews to a firm feel.
12. The telescope is now completely assembled. To move the telescope and point it from one object to another, first slightly loosen one of the chrome-lock (star-shaped) knobs (**5, Fig. 1**) which serve as a vertical lock, then loosen the azimuth (horizontal) lock (**6, Fig. 1**). Also, slightly loosen the altitude coarse adjustment lock knob (**17, Fig. 1**). Loosening these locks allows the telescope to be moved freely (vertically or horizontally) in any direction so that the telescope can be positioned to center a terrestrial or celestial object in the telescopic field. Once an object is found, the altitude lock knob (**17, Fig. 1**) can be tightened and the altitude slow-motion fine-adjustment control knob (**16, Fig. 1**) can then be used to make very smooth and accurate tracking in the vertical axis.

## VIEWFINDER FOCUSING AND ALIGNMENT

The 5 x 24mm viewfinder (**2, Fig. 1**) is a low-power, wide-field sighting device that, once aligned, will allow you to point the telescope with greater precision. **Note:** *When you look through the viewfinder, you will see a crosshair with images that will be upside-down; this is normal.*

To work properly, the viewfinder must first be aligned to the telescope's main optical tube. To align the viewfinder, follow these steps:

1. Remove the lens cap (**22, Fig. 1**) of the optical tube assembly. Insert the 25mm wide-field eyepiece into the diagonal mirror (**13, Fig. 1**). Point the optical tube assembly (**4, Fig. 1**) at a distant land object (e.g. a distant telephone pole). Make sure the detail of the distant object you have chosen is in sharp focus. Focusing is accomplished by turning the focusing knob (**23, Fig. 1**) until the sharpest possible image is attained.
2. Center the viewfinder (**2, Fig. 1**) in both the front and rear rings using the collimation screws (**3, Fig. 1**). Next, looking through the viewfinder, adjust the collimation screws on the rear ring until the object centered in the telescope's main tube is likewise positioned in the center of the viewfinder's crosshairs. Now it is possible to quickly sight an object in the wide-field viewfinder first, then find that object approximately centered in the narrower field of the 25mm eyepiece of the telescope.
3. If the viewfinder's infinity image is not in sharp focus, the knurled end of the eyepiece can be turned to fine tune the focus. Be sure to hold the viewfinder firmly between your fingers when making this adjustment.

## USING THE TELESCOPE

With the telescope assembled, you are ready to begin observations.

1. First, pick out an easy-to-find object. Observing land objects during the daytime is a good way to become accustomed to the operation of the telescope. At night, try observing the Moon at first (if it is visible) or a bright star.

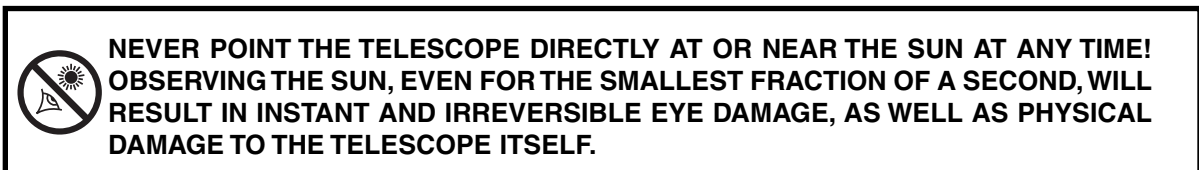

2. To center an object in the main telescope, first use the aligned viewfinder to find the object you wish to observe. If necessary, slightly loosen the vertical lock (**5, Fig. 1**) and the altitude rod lock knob (**17, Fig. 1**) to re-position the telescope so that the desired object can be centered in the viewfinder. When the object is centered in the viewfinder, it should then, also, be somewhere in the main telescope's field of view. Next, using the 25mm eyepiece, center the object in the main telescope's field of view, and sharply focus the image by turning the focus knob (**23, Fig. 1**).

The wide-field MA25mm eyepiece included as standard equipment is the best eyepiece to use for the initial finding and centering of an object. The low-power MA25mm eyepiece presents a bright, wide field of view, ideal for terrestrial and general astronomical observing of star fields, clusters of stars, nebulae, and galaxies. For lunar and planetary viewing, switch to a higher power eyepiece such as the MA9mm—if you have good viewing conditions. If the image starts to become fuzzy as magnification is increased, back down to a lower power; The atmosphere is not steady enough to support higher powers. **Note:** *Changing eyepieces changes power.*

3. If you are observing an astronomical object (the Moon, a planet, star, etc.) you will notice that the object will begin to move slowly through the telescopic field of view. This movement is caused by the rotation of the Earth and makes an object appear to be moving in the telescope's field of view. To keep astronomical objects centered in the field, simply move the telescope on one or both of its axes (vertical and/or horizontal) as appropriate. At higher powers, astronomical objects will seem to move through the field of view of the eyepiece more rapidly.

**Observing Tip:** Place the object to be viewed at the edge of the field and, without touching the telescope, watch it drift through the field to the other side before repositioning the telescope so that the object to be viewed is again placed at the edge of the field, ready to be further observed.

4. Avoid touching the eyepiece while observing through the telescope. Vibrations resulting from such contact will cause the image to move. Avoid observing sites where vibrations may introduce image movement. Viewing from the upper floors of a building may also introduce image movement.
5. Allow a few minutes for your eyes to become “dark adapted” prior to attempting any serious observations. Use a red-filtered flashlight to protect your night vision when reading star maps, or inspecting components of the telescope. **Tip:** You can make your own red filtered flashlight by taping red cellophane over a flashlight lens.
6. Avoid setting up the telescope inside a room and observing through an opened or closed window pane. Images may appear blurred or distorted due to temperature differences between inside and outside air. Also, it is a good idea to allow your telescope to reach the ambient (surrounding) outside temperature before starting an observing session.
7. Planets and other objects viewed low on the horizon often lack sharpness—the same object, when observed higher in the sky, will appear sharper and have greater contrast. Turbulent air in the atmosphere can cause images to “shimmer” in the eyepiece. Try reducing power (change your eyepiece) until the image steadies. Keep in mind that a bright, clear, but smaller image is more interesting than a larger, dimmer, fuzzy one.
8. Astronomical software or a good star atlas will assist you in locating many interesting celestial objects. These objects include:
  - The Moon, covered with craters, mountain ranges, and fault lines. The Moon is best observed during its crescent or half phase when Sunlight strikes the Moon's surface at an angle. It casts shadows and adds a sense of depth to the view. No shadows are seen during a full Moon, causing the bright Moon to appear flat and uninteresting.
  - Cloud belts across the surface of the planet Jupiter.
  - The 4 major moons of Jupiter, changing position each night.
  - Saturn and its famous ring system.
  - Deep-Space: Nebulae, galaxies, multiple star systems, star clusters—hundreds of such objects are visible through your Telestar telescope. If possible, observe under a dark sky, away from city lights—you will be able to observe more deep-space objects through your Telestar telescope.
  - Terrestrial objects: Your Telestar telescope may also be used for high-resolution land viewing. **Important Note:** Using the diagonal mirror results in an image which is reversed left-for-right, but which is correctly oriented up-and-down.  
Terrestrial observations should almost always be made using the 25mm low-power eyepiece for bright, sharp images. Observing horizontally through the Earth's atmosphere distorts images in higher-power eyepieces (such as 9mm).

## CALCULATING POWER

The power (magnification) at which a telescope is operating is calculated by dividing the focal length of the telescope by the focal length of the eyepiece. The focal length of the 60-AZ-A telescope is identified on the focuser label as being 700mm (F = 700mm). The focal length of the eyepiece is usually identified on the top of the eyepiece barrel.

For example, if you are using a 25mm eyepiece, the resulting power will be:

$$\text{Power} = 700\text{mm} \div 25\text{mm} = 28\text{X}.$$

For example, if you are using a 9mm eyepiece, the resulting power will be:

$$\text{Power} = 700\text{mm} \div 9\text{mm} = 78\text{X}.$$

The purpose of a Barlow lens is to increase the magnification possible with a given eyepiece. The 2x Barlow supplied with this telescope will double the normal eyepiece power. For example, the 25mm (28X) eyepiece, when used in conjunction with the 2x Barlow lens, yields 56X. The 9mm (78X) eyepiece yields 156X when used with the 2x Barlow lens.

To use the 2x Barlow lens, insert the 2x Barlow lens into the diagonal mirror (**13, Fig. 1**) followed by the 25mm eyepiece (**1, Fig. 1**). Refocus until the image is sharp.

## POWER AND EYEPIECES

The useful higher magnification with any 60mm diameter telescope is in the range of 80 to 120 power. The general rule to follow with any telescope, regarding power: Only use as much magnification as a steady, well-defined image supports. The stability of the air varies and is one reason why having various eyepieces is desirable. Higher powers are no guaranty of better images; in fact, the opposite is often true.

## MAINTENANCE

As with any quality optical instrument, lens surfaces should be cleaned as infrequently as possible. A little dust on the surface of the objective lens (**14, Fig. 1**) causes negligible degradation of image quality and should not be considered reason to clean the lens. When lens cleaning does become necessary, use a camel hair brush or compressed air to gently remove dust. Wipe only with a soft, clean cloth, applying as little pressure as possible to avoid scratching glass surfaces. **Note:** Gently pull off and remove the dew shield/lens shade (**21, Fig. 1**) to access the objective lens (**14, Fig. 1**).

## SPECIFICATIONS

Objective (main) lens focal length	.700mm
Objective lens diameter	.60mm (2.4")
Focal ratio	f/11.7
Mounting type	.Altazimuth

## OPTIONAL ACCESSORIES

**#928 45° Erecting Prism (1.25 O.D.):** Correctly orients the telescopic image during terrestrial observing and yields an image position at a 45° angle to the main telescope tube, resulting in a more comfortable observing position in most cases.

**Additional Eyepieces (1.25" barrel diameter):** For higher or lower magnifications with the telescopes that accommodate 1.25" eyepieces, Meade 3-element Modified Achromatic eyepieces, available in a wide variety of sizes, provide a high level of image resolution and color correction at an economical price. Also, at slightly higher prices, Meade 4-element Series 3000 Plössl eyepieces yield wider fields of view with excellent edge-of-field corrections and are available in a range of focal lengths including 5, 6.7, 9.5, 16, 25, and 40mm.



**MEADE®**

6001 Oak Canyon, Irvine, California 92618  
(949) 451-1450 ■ www.meade.com