

## Appendix A. CRU instructions

To replace the hard disk drive, do the following:

- ❶ Turn off the computer; then disconnect the AC adapter and all cables from the computer.
- ❷ Close the computer display, and then turn the computer over.
- ❸ Remove the battery pack.
- ❹ Remove the keyboard.

a. Remove the screws under the battery pack that secure the keyboard ❶.

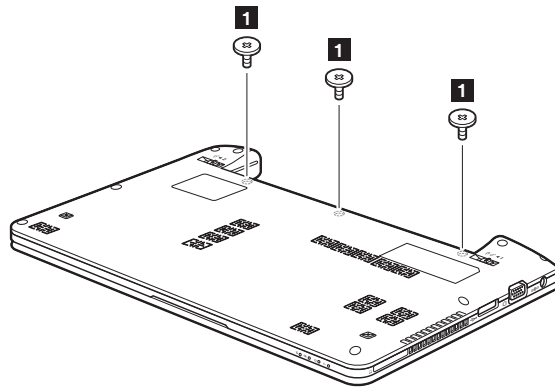

b. Remove the keyboard ❷.

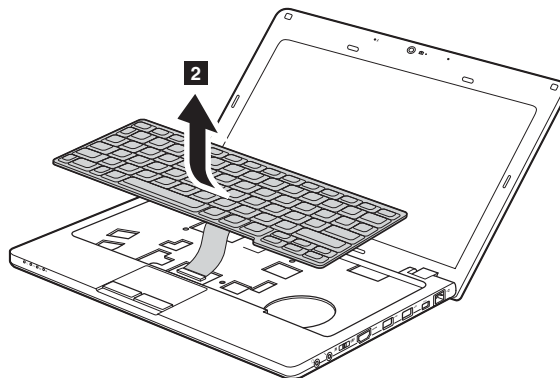

## Appendix A. CRU instructions

5 Remove the base cover.

a. Remove the screws that secure the base cover 3.

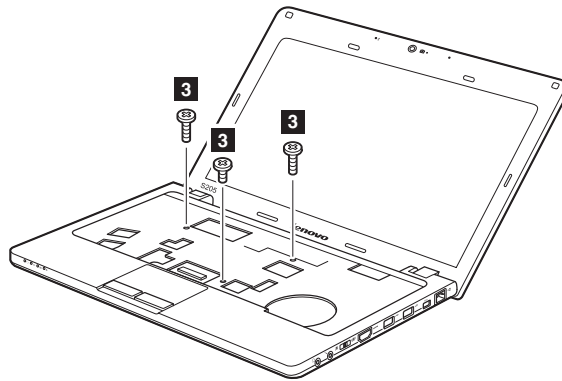

b. Remove the base cover 4.

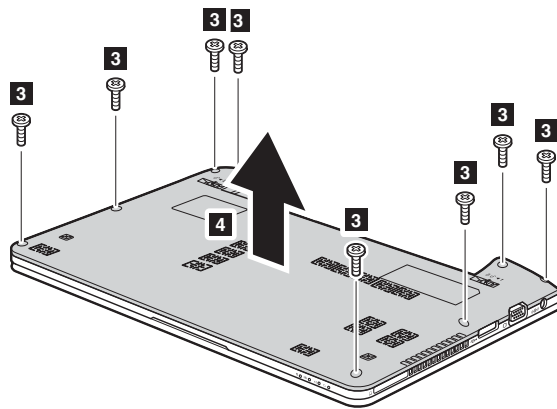

## Appendix A. CRU instructions

- 6 Remove the frame fixing screws.

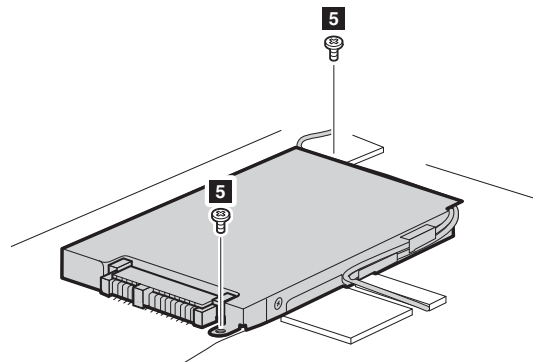

- 7 Release the cables from the cable guides of the hard disk drive frame and pull the tab in the direction shown by arrow 7.

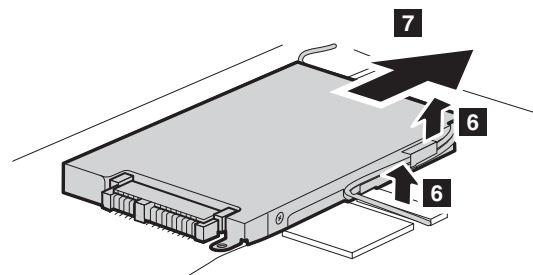

- 8 Take out the hard disk drive secured in the hard disk drive bay.
- 9 Remove the screws and detach the metal frame from the hard disk drive.
- 10 Attach the metal frame to a new hard disk drive; then tighten the screws.
- 11 Put the hard disk drive gently into the hard disk drive bay with the tab facing upwards and the connectors facing each other; then push it firmly into space.
- 12 Reinstall the frame fixing screws.
- 13 Reinstall the base cover and the keyboard.
- 14 Reinstall the battery pack.
- 15 Turn the computer over again. Connect the AC adapter and the cables to the computer again.

### ■ ■ Replacing memory

You can increase the amount of memory in your computer by installing a double-data-rate three synchronous dynamic random access memory (DDR3 SDRAM)-available as an option-in the memory slot of your computer. DDR3 SDRAMs are available in various capacities.

**Note:** Use only the memory types supported by your computer. If you incorrectly install optional memory, or install an unsupported memory type, a warning beep will sound when you try to start the computer.

To install a DDR3 SDRAM, do the following:

- ❶ Touch a metal table or a grounded metal object to reduce any static electricity in your body, which could damage the DDR3 SDRAM. Do not touch the contact edge of the DDR3 SDRAM.
- ❷ Turn off the computer. Disconnect the AC adapter and all cables from the computer.
- ❸ Close the computer display, and turn the computer over.
- ❹ Remove the battery again.
- ❺ Remove the keyboard.
  - a. Remove the screws under the battery pack that secure the keyboard ❶.

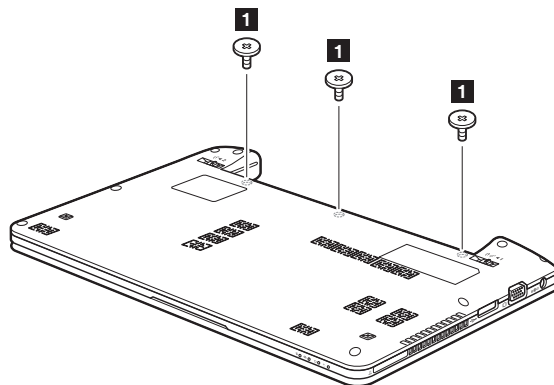

## Appendix A. CRU instructions

b. Remove the keyboard **2**.

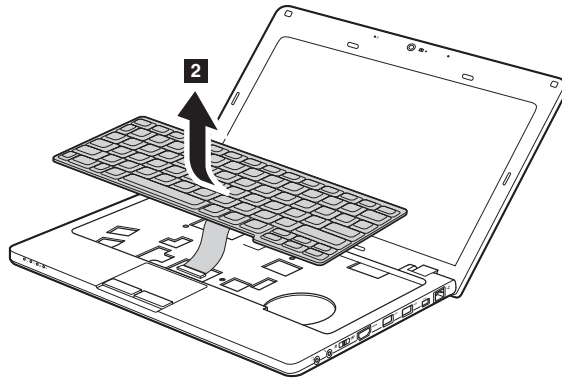

6 Remove the base cover.

a. Remove the screws that secure the base cover **3**.

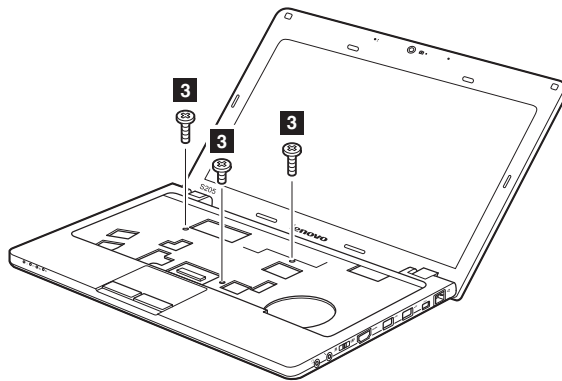

## Appendix A. CRU instructions

b. Remove the base cover **4**.

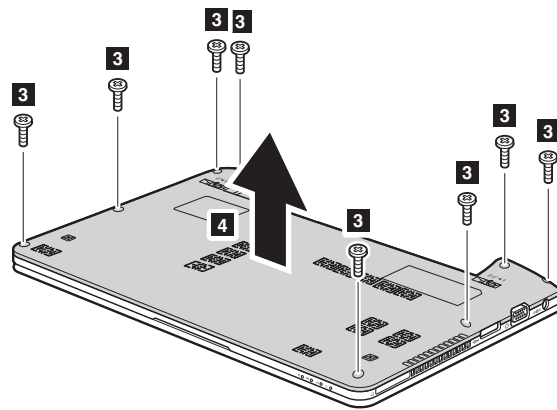

- 7 If two SO-DIMMs are already installed in the memory slot, remove one of them to make room for the new one by pressing out on the latches on both edges of the socket at the same time. Be sure to save the old SO-DIMM for future use.

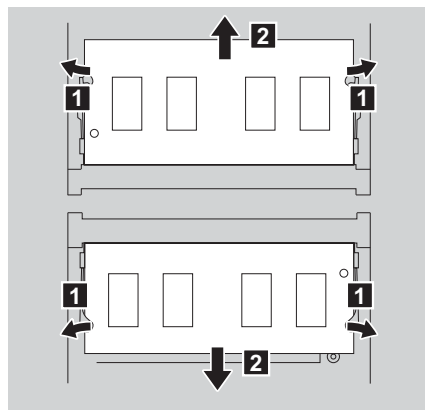

## Appendix A. CRU instructions

- ⑧ Insert the notched end of the DIMM into the socket.  
Press the DIMM firmly, and pivot it until it snaps into place. Make sure that it is firmly fixed in the slot and does not move easily.
- ⑨ Reinstall the base cover and the keyboard.
- ⑩ Reinstall the battery.
- ⑪ Turn the computer over, and reconnect the AC adapter and the cables to the computer.

To make sure that the SO-DIMM is installed correctly, do as follows:

- ① Turn the computer on.
- ② Hold **F2** during startup. The **BIOS Setup Utility** screen opens. The **Total Memory** item shows the total amount of memory installed in your computer.

## Appendix A. CRU instructions

The following table provides a list of CRUs (Customer Replaceable Units) for your computer, and informs you of where to find replacement instructions.

	Setup Poster	User Guide
AC adapter	○	
Power cord for AC adapter	○	
Battery	○	○
Bottom access doors		○
Hard disk drive		○
Memory		○
Optical drive		○



## Index

<b>A</b>		<b>O</b>	
AC adapter		OneKey Rescue System button.....	28
Using.....	9	<b>P</b>	
<b>B</b>		Password	
Battery		Using .....	20
Charging.....	9	<b>S</b>	
Bluetooth		Security .....	19
Connecting.....	16	SIM card .....	26
<b>C</b>		<b>T</b>	
Camera .....	1, 13	Touchpad .....	11
<b>E</b>		<b>U</b>	
ExpressCard/34 slot .....	15	USB port.....	3, 15
<b>F</b>		<b>V</b>	
Function key combinations.....	12	VeriFace	
<b>K</b>		Using .....	19
Keyboard			
Using.....	12		
<b>M</b>			
Memory card reader .....	14		
Microphone			
Built-in .....	1		



**lenovo**

New World. New Thinking.™  
[www.lenovo.com](http://www.lenovo.com)

©Lenovo China 2010

# Lenovo

Ideapad S205

Regulatory Notice v1.0

***lenovo***

## ■ ■ Lenovo regulatory notice for wireless modules

---

### ■ Read first — regulatory information

Please read this document before you use the Lenovo computer. Lenovo computer complies with the radio frequency and safety standards of any country or region in which it has been approved for wireless use. You must install and use your computer in strict accordance with the instructions as described hereafter.

You are prohibited to replace or remove the preinstalled Wireless LAN Mini PCI Express Card and the Bluetooth module in your computer, it is not a Customer Replaceable Unit (CRU). If one of your cards requires replacement or repair, Lenovo will request you to send your computer with the preinstalled card(s) to Lenovo so that Lenovo will repair it.

Veillez lire ce document avant d'utiliser l'ordinateur Lenovo. L'ordinateur Lenovo est conforme aux normes de sécurité et de radiofréquence du pays ou de la région où son utilisation sans fil est agréée. Vous devez installer et utiliser votre ordinateur en respectant scrupuleusement les instructions décrites ci-après.

Vous êtes interdit de remplacer la carte de réseau local sans fil Express mini-PCI et le module Bluetooth qui sont préinstallés dans votre ordinateur, ce ne sont pas des Unités remplaçables par l'utilisateur (CRU). Si l'une de votre carte a besoin d'être remplacée ou réparée, Lenovo va vous demander de lui envoyer votre ordinateur avec des cartes préinstallées, pour qu'il puisse le réparer.

### ■ USA — Federal Communications Commission (FCC)

#### **I. Factory preinstalled Wireless LAN/WiMAX module**

- FCC ID: PPD-AR5B95 (Model: AR5B95)
- FCC ID: VQF-RT3090-1T1R (Model: RT3090)

Wireless LAN Mini PCI Express Cards marketed in the USA and Canada do not support nor function in the extended channels (12ch, 13ch).

#### **i) The FCC RF Exposure compliance:**

The radiated energy from the auxiliary antenna connected to models AR5B95 and RT3090 conforms to the FCC limit of the SAR (specific absorption rate) requirement regarding 47 CFR Part 2 section 1093.

#### **ii) FCC ID of wireless module:**

On the bottom side of your Lenovo computer, you will find an indicator label of the format "Contains Transmitter Module: FCC ID XXXX", where XXXX represents the FCC ID that corresponds to your preinstalled Wireless LAN/WiMax module.

**iii) Radio Frequency interference requirements:**

- The devices have been tested and found to comply with the limits for a Class B digital device pursuant to FCC Part 15 Subpart B. Refer to “Electronic emission notices” on page 5. The models AR5B95 and RT3090 underwent the certification process with each respective FCC ID number listed in “I. Factory preinstalled Wireless LAN/WiMAX module” on page 1.
- Each device is restricted to indoor use due to its operation in the 5.15 to 5.25 GHz frequency range. FCC requires these products to be used indoors for the frequency range 5.15 to 5.25 GHz to reduce the potential for harmful interference to co-channel Mobile Satellite systems.
- High power radar are allocated as primary users of the 5.25 to 5.35 GHz and 5.65 to 5.85 GHz bands. These radar stations can cause interference with and/or damage this device.

**II. Preinstalled integrated *Bluetooth* module**

- FCC ID: QDS-BRCM1043 (Model: BCM92070MD\_REF)

**i) FCC ID and installation of the module:**

If you find an indication “Contains Transmitter Module: FCC ID: QDS-BRCM1043 on the label at the bottom side of your computer, your computer contains the Bluetooth transmitter module (Model: BCM92070MD\_REF). The *Bluetooth* module is preinstalled by Lenovo, and is not removable by users.

**ii) The FCC RF safety requirement:**

The radiated output power of the *Bluetooth* module is far below the FCC radio frequency exposure limits. Therefore, a 20 cm of separation between the *Bluetooth* antenna and human body is not required.

**iii) Radio Frequency interference requirements:**

The device has been tested and found to comply with the limits for both a Class B digital device regarding FCC Part 15 Subpart B and an intentional radiator regarding FCC Part 15 Subpart C; then it underwent the certification processes for both rules. Thus the FCC ID: QDS-BRCM1043 of this device includes both certifications of Part 15 Subpart B and C/E.

**III. Simultaneous use of RF transmitters**

Your Lenovo computer is approved for simultaneous use of the transmitters listed below:

- Wireless LAN adapter (FCC ID: PPD-AR5B95, VQF-RT3090-1T1R).
- *Bluetooth* module FCC ID: QDS-BRCM1043 (Model: BCM92070MD\_REF)

Please make sure of the following conditions on use of these wireless features:

1. When you use any other RF option device, all other wireless features including the above integrated devices in your Lenovo computer are required to be turned off.
2. Users must follow the RF Safety instructions on wireless option devices that are included in the RF option device’s user’s manual.

## ■ Canada — Industry Canada (IC)

### IC Certification number

#### I) Factory preinstalled Wireless LAN modules:

- IC: 4104A-AR5B95 (Model: AR5B95)
- IC: 7542A-RT30901T1R (Model: RT3090)

Wireless LAN Mini PCI Express Cards marketed in the USA and Canada do not support nor function in the extended channels (12ch, 13ch).

There is no certification number of Industry Canada for Mini PCI Express Card shown on the enclosure of your Lenovo computer. Instead you will find an indicator label pointing to the location of the IC Certification number on the bottom side of your Lenovo computer. This label will be of the format "Contains Transmitter Module: Canada IC: XXXX", where XXXX represents the IC ID that corresponds to your preinstalled WLAN module.

#### II) Preinstalled integrated *Bluetooth* module:

- IC: 4324A-BRCM1043 (Model: BCM92070MD\_REF)

If you find an indication "Contains Transmitter Module: Canada IC: 4324A-BRCM1043 on the label at the bottom side of your computer, your computer integrates the *Bluetooth* transmitter module. The *Bluetooth* module is preinstalled by Lenovo, and is not removable by users.

#### III) Low power license-exempt radiocommunication devices (RSS-210):

Operation is subject to the following two conditions:

1. This device may not cause interference, and
2. this device must accept any interference, including interference that may cause undesired operation of the device.

The transmitter devices have been designed to operate with the antennas integrated in Lenovo computer, and having a maximum gain of within 3 dBi.

The maximum antenna gain permitted for devices in the 5250-5350 MHz, 5470-5725 MHz, and 5725-5825 MHz bands complies with the e.i.r.p. limit in section A9.2 of RSS-210.

#### IV) Exposure of humans to RF fields (RSS-102):

Lenovo computers employ low gain integral antennas that do not emit RF field in excess of Health Canada limits for the general population; consult Safety Code 6, obtainable from Health Canada's Web site at [www.hc-sc.gc.ca/rpb](http://www.hc-sc.gc.ca/rpb)

The radiated energy from the antennas connected to the wireless adapters conforms to the IC limit of the RF exposure requirement regarding IC RSS-102, Issue 2 clause 4.2.

## **Numéro d'homologation IC**

### **I) Modules de réseaux local sans fil pré-installé à l'usine:**

- IC: 4104A-AR5B95 (Model: AR5B95)
- IC: 7542A-RT30901T1R (Model: RT3090)

Les cartes de réseau local sans fil Express mini-PCI commercialisées aux Etats-Unis et au Canada ne prennent pas en charge les canaux étendus (12ch, 13ch) et ne fonctionnent donc pas sur de tels canaux.

Le boîtier de votre ordinateur Lenovo ne comporte pas de numéro d'homologation IC (Industry Canada) pour la carte mini-PCI Express ; mais sous votre Lenovo, vous trouverez une étiquette indicatrice pointant vers l'emplacement du numéro d'homologation IC. L'étiquette se présente sous la forme "Contains Transmitter Module: Canada IC: XXXX" où XXXX représente l'ID IC qui correspond au module WLAN préinstallé.

### **II) Module *Bluetooth* intégré préinstallé:**

- IC: 4324A-BRCM1043 (Modèle: BCM92070MD\_REF)

Si la mention "Contains Transmitter Module: Canada IC: 4324A-BRCM1043" figure sur l'étiquette située au bas de votre ordinateur, cela signifie que ce dernier intègre le module de transmission *Bluetooth*. Le module *Bluetooth* est préinstallé par Lenovo et ne peut pas être retiré par les utilisateurs.

### **III) Remarque relative aux appareils de communication radio de faible puissance sans licence (CNR-210):**

Le fonctionnement de ce type d'appareil est soumis aux deux conditions suivantes:

1. Cet appareil ne doit pas perturber les communications radio, et
2. cet appareil doit supporter toute perturbation, y compris les perturbations qui pourraient provoquer son dysfonctionnement.

Les périphériques d'émission sont conçus pour fonctionner avec des antennes intégrées aux Lenovo et ayant un gain maximal de moins de 3 dBi.

Le gain d'antenne maximal pour les périphériques dans les bandes de fréquence 5250-5350 MHz, 5470-5725 MHz, et 5725-5825 MHz est conforme à la limite p.i.r.e énoncée dans la section A9.2 de la CNR-210.

### **IV) Exposition des êtres humains aux champs radioélectriques (RF) (CNR-102):**

L'ordinateur Lenovo utilise des antennes intégrales à faible gain qui n'émettent pas un champ électromagnétique supérieur aux normes imposées par le Ministère de la santé canadien pour la population. Consultez le Safety Code 6 sur le site Web du Ministère de la santé canadien à l'adresse "[www.hc-sc.gc.ca/rpb](http://www.hc-sc.gc.ca/rpb)".

L'énergie émise par les antennes reliées aux adaptateurs sans fil respecte la limite d'exposition aux radiofréquences telle que définie par Industrie Canada dans la clause 4.2 du document CNR-102.



## ■ Electronic emission notices

### Federal Communications Commission (FCC) Statement

**Note:** The compliance of the FCC Part 15 Subpart B for Models: AR5B95, RT3090 was proceeded by certification, thus the FCC ID: PPD-AR5B95, VQF-RT3090-1T1R respectively include both compliances of Part 15 Subpart B and C/E.

This equipment has been tested and found to comply with the limits for a Class B digital device, pursuant to Part 15 of the FCC Rules. These limits are designed to provide reasonable protection against harmful interference in a residential installation. This equipment generates, uses, and can radiate radio frequency energy and, if not installed and used in accordance with the instructions, may cause harmful interference to radio communications. However, there is no guarantee that interference will not occur in a particular installation. If this equipment does cause harmful interference to radio or television reception, which can be determined by turning the equipment off and on, the user is encouraged to try to correct the interference by one or more of the following measures:

- Reorient or relocate the receiving antenna.
- Increase the separation between the equipment and receiver.
- Connect the equipment into an outlet on a circuit different from that to which the receiver is connected.
- Consult an authorized dealer or service representative for help.

Lenovo is not responsible for any radio or television interference caused by unauthorized changes or modifications to this equipment. Unauthorized changes or modifications could void the user's authority to operate the equipment.

This device complies with Part 15 of the FCC Rules. Operation is subject to the following two conditions: (1) this device may not cause harmful interference, and (2) this device must accept any interference received, including interference that may cause undesired operation.

#### Responsible Party:

Lenovo (United States) Incorporated  
1009 Think Place - Building One  
Morrisville, NC 27560  
Telephone: 1-919-294-5900



#### *Industry Canada Class B Emission Compliance Statement*

This Class B digital apparatus complies with Canadian ICES-003.

#### *Avis de conformité à la réglementation d'Industrie Canada*

Cet appareil numérique de la classe B est conforme à la norme NMB-003 du Canada.

## ■ Europe — EU Declaration of Conformity

Products intended for sale within the European Union are marked with the Conformité Européenne (CE) Marking, which indicates compliance with the applicable Directives and European Norms, and amendments, identified below.

**For model: BCM92070MD\_REF**



**For model: AR5B95**



**For model: RT3090**



### English

Hereby, **Lenovo® (Singapore) Pte. Ltd.**, declares that the modem and wireless equipment listed in this section are in compliance with the essential requirements and other relevant provisions of Directive 1999/5/EC.

#### **EU Frequency band restriction for a wireless LAN Mini PCI Express Card**

- This device is restricted to indoor use in the band 2454 to 2483.5 MHz in France.
- Usage of this device is limited to indoor in the band 5150 to 5350 MHz (channels 36, 40, 44, 48, 52, 56, 60, 64).

### Bulgarian

С настоящето **Lenovo (Singapore) Pte. Ltd.** декларира, че модемът и безжичното оборудване, посочени в този раздел, са в съответствие с основните изисквания и другите уместни условия на Директива 1999/5/EC.

#### **Ограничение на честотна лента в ЕС за безжична LAN Mini PCI Express Card**

- Това устройство е ограничено за употреба на закрито в честотната лента от 2454 до 2483,5 MHz във Франция.
- Употребата на това устройство е ограничена на закрито в диапазона от 5150 до 5350 Mhz (канали 36, 40, 44, 48, 52, 56, 60, 64).

### **Czech**

Lenovo (Singapore) Pte. Ltd. tímto prohlašuje, že modem a bezdrátová zařízení uvedená v této části jsou ve shodě se základními požadavky a dalšími relevantními ustanoveními směrnice 1999/5/EC.

### **Omezení EU pro frekvenční pásma bezdrátové síťové karty LAN Mini PCI Express**

- Použití zařízení je ve Francii omezeno na vnitřní prostory a frekvenční pásmo 2454 až 2483,5 MHz.
- Použití zařízení je omezeno na vnitřní prostory a frekvenční pásmo 5150 až 5350 Mhz (kanály 36, 40, 44, 48, 52, 56, 60, 64).

### **Danish**

Lenovo (Singapore) Pte. Ltd. erklærer hermed, at modem og trådløst udstyr, der er nævnt i dette afsnit, overholder de væsentlige krav og andre relevante bestemmelser i EU-direktiv 1999/5/EC.

### **Restriktioner for frekvensbånd i EU for Mini PCI Express-kort til trådløst LAN**

- I Frankrig må denne enhed kun bruges indendørs i frekvensbåndet 2454 til 2483,5 MHz.
- Brug af denne enhed er begrænset til indendørs brug i frekvensbåndet 5150 til 5350 MHz (kanal 36, 40, 44, 48, 52, 56, 60, 64).

### **German**

Hiermit erklärt Lenovo (Singapur) Pte. Ltd., dass der Modem und die drahtlosen Geräte, die in diesem Abschnitt aufgeführt sind, die Voraussetzungen und andere relevanten Richtlinien der Direktive 1999/5/EC erfüllen.

### **EU-Frequenzbandeinschränkung für eine Wireless LAN Mini-PCI-ExpressCard**

- Dieses Gerät ist in Frankreich für die Verwendung im Innenbereich im Frequenzband von 2.454 bis 2.483,5 konzipiert.
- Die Verwendung dieses Geräts ist im Innenbereich auf das Frequenzband von 5.150 bis 5.350 MHz (Kanäle 36, 40, 44, 48, 52, 56, 60, 64) beschränkt.

### **Estonian**

**Lenovo (Singapore) Pte. Ltd. kinnitab selles jaotises nimetatud modemi ja traadita side seadmete vastavust direktiivi 1999/5/EÜ põhinõuetele ja nimetatud direktiivist tulenevatele muudele asjakohastele sätetele.**

### **EL-i sagedusvahemiku piirang raadiokohtvõrgu mini-PCI-ekspresskaardi kohta**

- Seade on Prantsusmaal lubatud kasutamiseks siseruumides sagedusalas 2454–2483,5 MHz.
- Seadet on lubatud kasutada siseruumides sagedusalas 5150–5350 MHz (kanalid 36, 40, 44, 48, 52, 56, 60, 64).

### **Spanish**

**En este documento, Lenovo (Singapore) Pte. Ltd., declara que el módem y el equipo inalámbrico que aparecen en esta sección cumplen los requisitos esenciales y otras exigencias relevantes de la Directiva 1999/5/EC.**

### **Restricción de banda de frecuencia de la UE para una Tarjeta Express Mini PCI de LAN inalámbrica**

- Este dispositivo está diseñado para ser utilizado en interiores en la banda de 2454 a 2483,5 MHz en Francia.
- La utilización de este dispositivo está limitada a interiores en la banda de 5150 a 5350 MHz (canales 36, 40, 44, 48, 52, 56, 60, 64).

### **Greek**

Η Lenovo (Singapore) Pte. Ltd. δηλώνει με την παρούσα ότι το modem και ο εξοπλισμός ασύρματης σύνδεσης που αναφέρονται σε αυτή την ενότητα συμμορφώνονται με τις ουσιώδεις απαιτήσεις και άλλες σχετικές διατάξεις της Οδηγίας 1999/5/EC της Ευρωπαϊκής Ένωσης.

### **Περιορισμός εύρους συχνοτήτων στην ΕΕ για LAN Mini PCI Express Card ασύρματης σύνδεσης**

- Η χρήση αυτής της συσκευής περιορίζεται σε εσωτερικούς χώρους, στο εύρος συχνοτήτων 2454 - 2483,5 MHz στη Γαλλία.
- Η χρήση αυτής της συσκευής περιορίζεται σε εσωτερικούς χώρους, στο εύρος συχνοτήτων 5150 - 5350 MHz (κανάλια 36, 40, 44, 48, 52, 56, 60, 64).

## French

Par la présente, **Lenovo (Singapore) Pte. Ltd.** déclare que le modem et le matériel sans fil répertoriés dans cette section sont conformes aux exigences essentielles ainsi qu'aux autres dispositions applicables de la Directive 1999/5/CE.

### **Restriction liée à la bande de fréquence pour une carte mini-PCI Express pour réseau local sans fil au sein de l'Union Européenne**

- En France, ce périphérique est destiné à être utilisé uniquement à l'intérieur, dans la bande de fréquence de 2454 à 2483,5 MHz.
- Ce périphérique doit être utilisé exclusivement à l'intérieur, dans la bande de fréquence de 5150 à 5350 MHz (canaux 36, 40, 44, 48, 52, 56, 60, 64).

## Icelandic

Hér með lýsir **Lenovo (Singapore) Pte. Ltd.** því yfir að mótdið og þráðlaus búnaðurinn sem getið er í þessum hluta uppfylla allar kröfur og önnur viðkomandi ákvæði tilskipunar 1999/5/EC.

### **ESB Takmarkanir á tíðnisviði þráðlauss LAN Mini PCI staðarnetkorts**

- Í Frakklandi er þetta tæki eingöngu ætlað til notkunar innanhúss á tíðnisviðinu 2454 til 2483,5 MHz.
- Notkun þessa tækis er takmörkuð við innanhússnotkun á tíðnisviðinu 5150 til 5350 MHz (rásir 36, 40, 44, 48, 52, 56, 60, 64).

## Italian

Hereby, **Lenovo (Singapore) Pte. Ltd.**, dichiara che l'equipaggiamento modem e wireless elencato in questa sezione è conforme ai requisiti essenziali e ad altre disposizioni rilevanti della direttiva 1999/5/EC.

### **Restrizioni UE sulla banda di frequenza per una scheda wireless LAN Mini PCI Express**

- In Francia questo dispositivo è destinato all'utilizzo in ambienti chiusi nella banda di frequenza compresa tra 2454 e 2483,5 MHz.
- L'utilizzo di questo dispositivo è limitato ad ambienti chiusi in banda compresa tra 5150 e 5350 MHz (canali 36, 40, 44, 48, 52, 56, 60, 64).

### **Latvian**

Ar šo uzņēmums Lenovo (Singapūra) Pte. Ltd. paziņo, ka modems un bezvadu aparatūra, kas minēta šajā sadaļā, atbilst Direktīvas 1999/5/EK pamatprasībām un citiem ar to saistītajiem noteikumiem.

### **ES frekvenču joslas ierobežojums bezvadu LAN Mini PCI Express kartei**

- Šī ierīce Francijā ir paredzēta izmantošanai telpās joslās no 2454 līdz 2483,5 MHz.
- Šī ierīce ir paredzēta izmantošanai iekštelpās joslās no 5150 līdz 5350 MHz (kanālos 36, 40, 44, 48, 52, 56, 60, 64).

### **Lithuanian**

Šiuo, „Lenovo (Singapore) Pte. Ltd.“, pareiškia, kad šiame skyriuje nurodytas modemas ir belaidė įranga atitinka svarbiausius 1999/5/EB direktyvos reikalavimus ir kitas susijusias nuostatas.

### **Belaidžio „LAN Mini PCI Express Card“ ES dažnių diapazono apribojimas**

- Šis įrenginys skirtas naudoti patalpose, Prancūzijos dažnių diapazone nuo 2454 iki 2483,5 MHz.
- Šio prietaiso veikimas patalpoje ribojamas dažnių diapazone nuo 5150 iki 5350 MHz (kanalai: 36, 40, 44, 48, 52, 56, 60, 64).

### **Dutch**

**Hierbij verklaart Lenovo (Singapore) Pte. Ltd., dat de modem en draadloze apparatuur die in dit gedeelte worden genoemd, voldoen aan de essentiële vereisten en andere relevante bepalingen van Directive 1999/5/EC.**

### **EU-beperking van frequentieband voor een draadloze LAN Mini PCI Express Card**

- Gebruik van dit apparaat is in Frankrijk beperkt tot binnenshuis gebruik in de band van 2454 tot 2483,5 MHz.
- Gebruik van dit apparaat is beperkt tot binnenshuis gebruik in de band van 5150 tot 5350 MHz (kanalen 36, 40, 44, 48, 52, 56, 60, 64).

### Norwegian

Lenovo (Singapore) Pte. Ltd. erklærer herved at modemmet og det trådløse utstyret er i samsvar med de viktigste kravene og andre relevante bestemmelser i EU-direktiv 1999/5/EØF.

### Begrensinger for frekvensbånd i EU for et Mini PCI Express-kort for trådløst lokalnett (LAN)

- Denne enheten er beregnet på innendørs bruk i frekvensbåndet 2454 til 2483,5 MHz i Frankrike.
- Denne enheten er begrenset til innendørs bruk i frekvensbåndet 5150 til 5350 MHz (kanal 36, 40, 44, 48, 52, 56, 60, 64).

### Hungarian

A Lenovo (Szingapúr) Pte. Ltd. ezúton is kijelenti, hogy a modem és az itt feltüntetett rádiós eszköz megfelel az 1999/5/EC direktívában megfogalmazott alapvető követelményeknek és vonatkozó ajánlásoknak.

### EU frekvencia-sáv korlátozás a vezeték nélküli LAN Mini PCI Express kártyához

- Franciaországba az eszköz használata beltérre korlátozódik a 2454 - 2483,5 MHz tartományban.
- Az eszköz használata beltérre korlátozódik az 5150 - 5350 Mhz tartományban (36, 40, 44, 48, 52, 56, 60, 64 csatornák).

### Polish

Lenovo (Singapore) Pte. Ltd. deklaruje niniejszym, że modem i urządzenia bezprzewodowe wymienione w tej sekcji są zgodne z zasadniczymi wymaganiami i postanowieniami dyrektywy 1999/5/EC.

### Ograniczenia dotyczące pasm częstotliwości w UE dla karty Mini-PCI Express bezprzewodowej sieci LAN:

- We Francji urządzenie to jest przeznaczone do użytkowania wyłącznie wewnątrz budynków, w pasmach częstotliwości 2454 do 2483,5 MHz.
- Urządzenie jest przeznaczone do użytkowania wewnątrz budynków, w pasmach częstotliwości 5,15 do 5,35 GHz (kanały 36, 40, 44, 48, 52, 56, 60 i 64).

### Portuguese

A Lenovo (Singapore) Pte. Ltd., declara por este meio que o modem e o equipamento sem fios listado nesta secção se encontram em conformidade com os requisitos essenciais e com outras provisões relevantes da Directiva 1999/5/EC.

#### **Restrição de frequência de bandas da EU para placas Mini PCI Express Card de rede local sem fios**

- Na França, este dispositivo destina-se apenas a utilização no interior na banda de 2454 a 2483,5 MHz.
- A utilização deste dispositivo está limitada à utilização no interior, na banda de 5150 a 5350 MHz (canais 36, 40, 44, 48, 52, 56, 60, 64).

### Romanian

Prin aceasta, Lenovo (Singapore) Pte. Ltd., declară că modemul și echipamentul wireless prezentate în această secțiune respectă cerințele esențiale și celelalte prevederi pertinente ale Directivei 1999/5/EC.

#### **Restricțiile UE privind banda de frecvență pentru un dispozitiv wireless LAN Mini PCI Express Card**

- În Franța, acest dispozitiv este restricționat la utilizarea în spații interioare, în banda 2454-2483,5 MHz.
- Utilizarea acestui dispozitiv este limitată la spațiile interioare, în banda 5150-5350 Mhz (canalele 36, 40, 44, 48, 52, 56, 60, 64).

### Slovenian

S tem Lenovo (Singapore) Pte. Ltd., izjavlja, da modem in brezžična oprema, opisana v tem razdelku, ustrezata bistvenim zahtevam in drugim določbam smernice 1999/5/EC.

#### **Omejitev frekvenčnega pasu v EU za brezžično kartico LAN Mini PCI Express Card**

- Ta naprava je v Franciji omejena na hišno uporabo v pasu od 2454 do 2483,5 MHz.
- Ta naprava je omejena na hišno uporabo v pasu od 5150 do 5350 Mhz (kanali 36, 40, 44, 48, 52, 56, 60, 64).



### **Slovakian**

Týmto spoločnosť Lenovo (Singapore) Pte. Ltd. prehlasuje, že modem a bezdrôtové zariadenia uvedené v tejto časti sú v súlade s nevyhnutnými kritériami a inými príslušnými požiadavkami Smernice 1999/5/EC.

### **Obmedzenie frekvenčného pásma pre bezdrôtové adaptéry Wireless LAN Mini PCI Express Card v rámci EÚ**

- Použitie tohto zariadenia je obmedzené na použitie v interiéroch v pásme 2 454 až 2 483,5 MHz vo Francúzsku.
- Použitie tohto zariadenia je obmedzené na použitie v interiéroch v pásme 5 150 až 5 350 Mhz (kanály 36, 40, 44, 48, 52, 56, 60, 64).

### **Finnish**

Lenovo (Singapore) Pte. Ltd. ilmoittaa täten, että tässä jaksossa mainittu modeemi ja langaton laitteisto ovat direktiivin 1999/5/EY pakollisten vaatimusten ja direktiivin muiden asiaankuuluvien määräysten mukaiset.

### **Taajuusalueita koskeva Euroopan unionin asettama rajoitus Wireless LAN Mini PCI Express -kortille**

- Ranskassa tämä laite on tarkoitettu käytettäväksi sisätiloissa taajuusalueella 2454 - 2483,5 MHz.
- Tämä laite on tarkoitettu käytettäväksi sisätiloissa taajuusalueella 5150 - 5320 MHz (kanavat 36, 40, 44, 48, 52, 56, 60 ja 64).

### **Swedish**

Härmed intygar Lenovo (Singapore) Pte. Ltd att det modem och den trådlösa utrustning som anges i detta avsnitt överensstämmer med väsentliga krav och andra relevanta bestämmelser i direktiv 1999/5/EG.

### **Frekvensområdesbegränsning inom EU för ett PCI Express-minikort för radio-LAN**

- I Frankrike är enheten avsedd för inomhusbruk i frekvensområdet 2454 till 2483,5 MHz.
- Enheten är avsedd för inomhusbruk i frekvensområdet 5150 till 5350 MHz (kanal 36, 40, 44, 48, 52, 56, 60, 64).

For model: BCM92070MD\_REF



Mathilda Place, Sunnyvale, CA 94086.

Tel: 408 543 3300, Fax 408 543 3399

### Declaration of Conformity

We

Broadcom Corporation  
190 Mathilda Place  
Sunnyvale, CA 94086  
USA

Contact: Daniel Lawless  
Tel: +1 408 922 5870  
Fax: +1 408 543 3399

Hereby declare under our sole responsibility that the product:

Product Name: Broadcom Bluetooth Transceiver Module  
Model No: BCM92070MD\_REF

To which this declaration relates, is in conformity with the following standards and/or other normative documents:

EN 300 328 V1.7.1 (2006-10)  
EN 301 489-17 V2.1.1 (2009-05)  
EN 60950-1:2006 + A11: 2009  
EN50371: 2002

We hereby declare that all essential radio test suites have been carried out and that the above named product is in conformity with all the essential requirements of Directive 1999/5/EC.

The conformity assessment procedure referred to in Article 10(5) and detailed in Annex IV of Directive 1999/5/EC has been followed with the involvement of the following Conformity Assessment Body:

Compliance Certification Services (ID# 0984)

June 21, 2010

A handwritten signature in black ink, appearing to read 'D. Lawless', is written over a horizontal line.

Daniel Lawless  
Senior Manager, Compliance Engineering  
Broadcom Corporation

For model: AR5B95



**Declaration of Conformity**

We, the undersigned,

<b>Company</b>	Atheros Communications, Inc.
<b>Address, City</b>	5480 Great America Parkway, Santa Clara, CA 95054
<b>Country</b>	U.S.A.
<b>Phone number</b>	1-408-773-5200
<b>Fax number</b>	1-408-773-9940

certify and declare under our sole responsibility that the following equipment:

<b>Product description / Intended use</b>	802.11n Wireless LAN PCIe Minicard
<b>EU / EFTA member states intended for use</b>	All Member Countries
<b>Member states with restrictive use</b>	See Enclosed User Instructions Regarding operation in 2.4GHz bands
<b>Manufacturer</b>	HON HAI Precision IND.CO.,LTD.
<b>Type</b>	AR5B95

is tested to and conforms with the essential requirements for protection of health and the safety of the user and any other person and Electromagnetic Compatibility, as included in following standards:

<b>Standard</b>	<b>Issue date</b>
EN 301 489-17	Version 2.1.1
EN 60950-1	2006 + A11 : 2009
EN 50385	2002

and is tested to and conforms with the essential radio test suites so that it effectively uses the frequency spectrum allocated to terrestrial/space radio communication and orbital resources so to as to avoid harmful interference, as included in following standards:

<b>Standard</b>	<b>Issue date</b>
EN 300 328	Version 1.7.1

and therefore complies with the essential requirements and provisions of the **Directive 1999/5/EC** of the European Parliament and of the council of March 9, 1999 on Radio equipment and Telecommunications Terminal Equipment and the mutual recognition of their conformity and with the provisions of Annex IV (Conformity Assessment procedure referred to in article 10). The device complies with the RF Exposure Requirement **1999/519/EC, COUNCIL RECOMMENDATION** of 12 July 1999 on the limitation of exposure of the general public to electromagnetic fields (0 Hz to 300 GHz).

The technical documentation as required by the Conformity Assessment procedure is kept at the following address:

<b>Company</b>	Atheros GmbH
<b>Address, City</b>	Braunschweiger Str. 8, 45886 Gelsenkirchen
<b>Country</b>	Germany
<b>Phone number</b>	+49-209-1550955
<b>Fax number</b>	+49 209 1550956
<b>Contact</b>	Peter Grabienski
<b>Email</b>	Peter.Grabienski@Atheros.com

<b>Technical File ref. nr.</b>	AR5B95
<b>Drawn up in</b>	Santa Clara
<b>Date</b>	8 Sep 2010

	
<b>Name and position</b>	Michael Green, Manager Global Product Compliance

Atheros Communications, Inc. 5480 Great America Parkway Santa Clara CA 95054  
t 408 773 5200 f 408-773-9940 www.atheros.com

**For model: RT3090**

## **R&TTE Directive Declaration of Conformity**

Date: August 16, 2010

We,

Ralink Technology Corporation,

Hereby, declare that our product with detail below has fully fulfilled the requirement of European

R&TTE directive 1999/5/EC. This device will be sold in the following countries:

Belgium, Denmark, Germany, Greece, Spain, France, Ireland, Italy, Luxemburg, Netherlands, Austria,  
Portugal, Finland, Sweden, UK, Switzerland, Norway, Iceland, Cyprus, Czech Republic, Estonia,  
Hungary, Latvia, Lithuania, Malta, Slovakia, Poland, Slovenia, Bulgaria, Romania.

**Product Name:** 11b/g/n 1T1R WLAN Mini Card

**Brand Name:** Ralink

**Model / Type Name:** RT3090

The following European standards for essential requirements have been followed:

**Spectrum :** EN 300 328 V1.7.1 (2006-10)

**EMC :** EN 301 489-1 V.1.6.1 (2005-09)/ EN 301 489-17 V.1.2.1 (2002-08)

**Safety (LVD) :** EN 60950-1:2006 + A11:2009

**Safety (EMF) :** EN 50392: 2002

COUNCIL RECOMMENDATION Directive 1999/519/EC.

Furthermore, the in-process quality control procedure as well as the manufacturing process has fulfilled the requirement defined in ISO.

The technical document as well as the test reports will be kept for a period at least 10 years after the last product has been manufactured at the disposal of the relevant national authorities of any Member State for inspection. Detail contact information for this declaration has been listed below as the window of any issues relevant for this product.

Manufacturer Contact

Importer Contact

Signature :



Company : Ralink Technology Corporation

Name/Title : Rex Huang

Address : 5F., No.36, Taiyuan St., Jhubei City,  
Hsinchu County 302, Taiwan, R.O.C.

Tel. No. : +886-3-5600868

Fax No. : +886-3-5600898

E-Mail : rex\_huang@ralinktech.com.tw

■ Notice for users in Croatia

For model: BCM92070MD\_REF



REPUBLIKA HRVATSKA  
**HRVATSKA AGENCIJA ZA  
 POŠTU I ELEKTRONIČKE KOMUNIKACIJE**  
 Jurišićeva 13, p.p. 162, 10 000 ZAGREB, MB: 01865862  
 Tel: (01) 4896 000, (01) 4673 579, Fax: (01) 4920 227, web: www.telekom.hr

---

Klasa: 344-01/09-02/228  
 Ur. broj: 376-10/MS-09-2

**POTVRDA O SUKLADNOSTI**  
 CERTIFICATE OF CONFORMITY

**Broj: 0237/09**  
 No.:

**Podnositelj zahtjeva: Broadcom Corporation**  
*Applicant: 190 Mathilda Place, Sunnyvale, CA 94086, USA*

**Vrsta opreme: Bluetooth radijski modul**  
*Equipment category: Bluetooth Radio Module*

**Tipska oznaka opreme: BCM92070MD\_REF**  
*Equipment type designation:*

**Proizvođač opreme: Broadcom Corporation**  
*Equipment manufacturer: 190 Mathilda Place, Sunnyvale, CA 94086, USA*

**Dostavljena dokumentacija:**  
*Submitted documentation:*

Norme Standards	Ispitni izvještaji ili certifikati Test reports or Certificates	Ispitni laboratorij Test laboratory
IEC 60950-1: 2001; EN 60950-1: 2001+ A11 : 2004;	08U12247-6;	<b>COMPLIANCE CERTIFICATION SERVICES;</b>
EN 301 489-17 v1.3.2; EN 301 489-1 v1.8.1;	08U12247-4 Rev A;	
EN 300 328 v1.7.1;	08U12247-14;	

Nakon što je razmotrena gore navedena dostavljena dokumentacija, utvrđeno je da je sukladnost gore navedene opreme s bitnim zahtjevima iz članka 4. Pravilnika o radijskoj opremi i telekomunikacijskoj opremi (NN 112/08) pravilno dokazana. Punu odgovornost za gore navedenu dostavljenu dokumentaciju preuzima podnositelj zahtjeva.  
 Having considered above mentioned submitted documentation, it is determined that conformity of the above mentioned equipment with essential requirements of Article 4. of Ordinance on radio equipment and telecommunications terminal equipment (OG 112/08) has been properly demonstrated. Full responsibility for above mentioned submitted documentation takes an applicant.

Zagreb, 24.03.2009.

---

**Mjesto i Datum**  
Place and Date



**Zig potpis**  
Signature Sign

For model: AR5B95



REPUBLIKA HRVATSKA  
HRVATSKA AGENCIJA ZA  
POŠTU I ELEKTRONIČKE KOMUNIKACIJE  
Jurišićeva 13, p.p. 162, 10 000 ZAGREB, MB: 01865862  
Tel: (01) 4896 000, (01) 4673 579, Fax: (01) 4920 227, web: www.telekom.hr

Klasa: 344-01/09-02/329  
Ur. broj: 378-10/MS-09-2

### POTVRDA O SUKLADNOSTI

CERTIFICATE OF CONFORMITY

Broj: 0469/09

No.:

Podnositelj zahtjeva: ISTRA-KONTROL d.o.o.  
Applicant: Istarska 3, 52212 Fažana

Vrsta opreme: IEEE 802.11n WLAN PCIe Mini kartica  
Equipment category: IEEE 802.11n WLAN PCIe MiniCard

Tipaska oznaka opreme: AR5B95  
Equipment type designation:

Proizvođač opreme: Atheros Communications, Inc.  
Equipment manufacturer: 5480 Great America Parkway, Santa Clara, CA 95054, USA

Dostavljena dokumentacija:  
Submitted documentation:

Norme Standards	Ispitni izvještaji ili certifikati Test reports or Certificates	Ispitni laboratorij Test laboratory
EN 60950-1:2001+A11:2004; IEC 60950-1:2001;	81029005-LV;	Compliance Certification Services Inc.;
ETSI EN 301 489-1 v1.6.1:2005; ETSI EN 301 489-17 v1.2.1:2002;	81029005-RE;	
ETSI EN 300 328 v1.7.1: 2006;	81029005-RT1;	

Nakon što je razmotrena gore navedena dostavljena dokumentacija, utvrđeno je da je sukladnost gore navedene opreme s bitnim zahtjevima iz članka 4. Pravilnika o radljakoj opremi i telekomunikacijskoj opremi (NN 112/08) pravilno dokazana. Punu odgovornost za gore navedenu dostavljenu dokumentaciju preuzima podnositelj zahtjeva.  
Having considered above mentioned submitted documentation, it is determined that conformity of the above mentioned equipment with essential requirements of Article 4. of Ordinance on radio equipment and telecommunications terminal equipment (OG 112/08) has been properly demonstrated. Full responsibility for above mentioned submitted documentation rests on applicant.

Zagreb, 15.06.2009.

Mjesto i Datum  
Place and Date



For model: RT3090



REPUBLIKA HRVATSKA  
**HRVATSKA AGENCIJA ZA  
POŠTU I ELEKTRONIČKE KOMUNIKACIJE**  
Jurističeva 13, p.p. 162, 10 000 ZAGREB, MB: 01865862  
Tel: (01) 4896 000, (01) 4673 579, Fax: (01) 4920 227, web: www.telekom.hr

Klasa: 344-01/09-02/288  
Ur. broj: 376-10/MS-09-2

POTVRDA O SUKLADNOSTI CERTIFICATE OF CONFORMITY		
<b>Broj: 0285/09</b> No.:		
<b>Podnošitelj zahtjeva:</b> Applicant:	ISTRA-KONTROL d.o.o. Istarska 3, 52212 Fažana  u ime/on behalf of:  Ralink Technology Corporation SF., No.36, Taiyuan St., Jhubel City, Hsinchu County 302, Taiwan, R.O.C.	
<b>Vrsta opreme:</b> Equipment category:	IEEE 802.11 b/g/n WLAN mini kartica IEEE 802.11 b/g/n WLAN Mini Card	
<b>Tipška oznaka opreme:</b> Equipment type designation:	RT3090	
<b>Proizvođač opreme:</b> Equipment manufacturer:	Ralink Technology Corporation SF., No.36, Taiyuan St., Jhubel City, Hsinchu County 302, Taiwan, R.O.C.	
<b>Dostavljena dokumentacija:</b> Submitted documentation:		
Norme Standards	Ispitni izvještaji ili certifikati Test reports or Certificates	Ispitni laboratorij Test laboratory
IEC 60950-1:2001; EN 60950-1:2001+A11:2004;	L&N2012L1000;	Sporton International Inc.;
EN 60392:2002;	EA8N2012;	
EN 301 488-1 v1.6.1:2005; EN 301 488-17 v1.2.1:2002;	EH8N2012;	
ETSI EN 300 328 v1.7.1:2006;	ER8N2012;	
<small>Nakon što je razmotrena gore navedena dostavljena dokumentacija, utvrđeno je da je sukladnost gore navedene opreme s bitnim zahtjevima iz članka 4. Pravilnika o radijskoj opremi i telekomunikacijskoj opremi (NN 112/08) pravilno dokazana. Punu odgovornost za gore navedenu dostavljenu dokumentaciju preuzima podnošitelj zahtjeva. Having considered above mentioned submitted documentation, it is determined that conformity of the above mentioned equipment with essential requirements of Article 4. of Ordinance on radio equipment and telecommunications terminal equipment (OG 112/08) has been properly demonstrated. Full responsibility for above mentioned submitted documentation takes an applicant.</small>		

Zagreb, 17.04.2009.

Mjesto i Datum  
Place and Date



■ Notice for users in Taiwan

For models: BCM92070MD\_REF, AR5B95, RT3090

低功率電波輻射性電機管理辦法

第十二條 經型式認證合格之低功率射頻電機，非經許可，公司、商號或使用者均不得擅自變更頻率、加大功率或變更原設計之特性及功能。

第十四條 低功率射頻電機之使用不得影響飛航安全及干擾合法通信；經發現有干擾現象時，應立即停用，並改善至無干擾時方得繼續使用。

前項合法通信，指依電信法規定作業之無線電通信。

低功率射頻電機須忍受合法通信或工業、科學及醫療用電波輻射性電機設備之干擾。



## Lenovo の内蔵アダプターを日本国内でご使用になる際の注意

### 日本国内で無線 LAN アダプターおよび Bluetooth アダプターをご使用になる場合の注意

本製品が装備する無線アダプターは電波法および電気通信事業法により技術基準認証を取得している下記の機器です。

#### 無線 LAN アダプターの場合

認証製品名 :	AR5B95	RT3090
認証申請者名 :	Antheros Communications, Inc.	Ralink Technology Corporation
認証番号 :	003GZA081037	D09-0140001
	003WWA081036	
	D081038003	

#### Bluetooth アダプターの場合

認証製品名 :	BCM92070MD_REF
認証申請者名 :	Broadcom Corporation
認証番号 :	003WWA090043

本製品に組み込まれた無線設備を他の機器で使用する場合は、当該機器が上記と同じく認証を受けていることをご確認ください。認証されていない機器での使用は、電波法の規定により認められていません。

(5 GHz の場合)

ご使用の Lenovo に IEEE802.11a/n 準拠の無線機器が搭載されている場合は、5.15-5.35 GHz 周波数帯での使用は、電波法の規定により屋内に限られます (屋外での使用は禁じられています)。

(2.4 GHz の場合)

この機器の使用周波数帯では、電子レンジ等の産業・科学・医療用機器のほか工場の製造ライン等で使用されている移動体識別用の構内無線局 (免許を要する無線局) および特定小電力無線局 (免許を要しない無線局) 並びにアマチュア無線局 (免許を要する無線局) が運用されています。

1. この機器を使用する前に、近くで移動体識別用の構内無線局及び特定小電力無線局並びにアマチュア無線局が運用されていないことを確認してください。
2. 万一、この機器から移動体識別用の構内無線局に対して電波干渉の事例が発生した場合には、速やかに使用周波数を変更するかまたは電波の発射を停止した上で、下記連絡先にご連絡頂き、混信回避のための処置等についてご相談ください。
3. その他、この機器からの移動体識別用の特定小電力無線局あるいはアマチュア無線局に対して有害な電波干渉の事例が発生した場合など何かお困りのことが起きたときには、次の連絡先にお問い合わせください。

連絡先 : スマートセンター (スマートセンターのご利用方法は、次のホームページでご確認ください)。

<http://www.ibm.com/jp/pc/support/contact/smartctr/>

### 無線 LAN アダプター (IEEE802.11b/g 準拠) の場合



この機器が、2.4GHz 周波数帯 (2400 から 2483.5MHz) を使用する直接拡散 (DS) 方式および直交周波数分割多重方式 (OFDM) の無線装置で、干渉距離が約 40m (定格出力 10mW/MHz) であることを意味しています。

### Bluetooth アダプターの場合



この機器が、2.4GHz 周波数帯 (2400 から 2483.5MHz) を使用する周波数ホッピング (FH) 方式の無線装置で、干渉距離が約 10m であることを意味します。

以上の内容は、「社団法人 電波産業会」ARIB STD-T66 の主旨に基づくものです。

### 無線 LAN 製品ご使用時におけるセキュリティに関するご注意

無線 LAN では、LAN ケーブルを使用する代わりに、電波を利用してパソコン等と無線アクセスポイント間で情報のやり取りを行うため、電波の届く範囲であれば自由に LAN 接続が可能であるという利点があります。その反面、電波はある範囲内であれば障害物 (壁等) を越えてすべての場所に届くため、セキュリティに関する設定を行っていない場合、以下のような問題が発生する可能性があります。

- ・ 通信内容を盗み見られる 悪意ある第三者が、電波を故意に傍受し、
  - ID やパスワード又はクレジットカード番号等の個人情報
  - メールの内容等の通信内容を盗み見られる可能性があります。
- ・ 不正に侵入される 悪意ある第三者が、無断で個人や会社内のネットワークへアクセスし、
  - 個人情報や機密情報を取り出す (情報漏洩)
  - 特定の人物になりすまして通信し、不正な情報を流す (なりすまし)
  - 傍受した通信内容を書き換えて発信する (改ざん)
  - コンピュータウイルスなどを流しデータやシステムを破壊する (破壊)などの行為をされてしまう可能性があります。

本来、無線 LAN カードや無線アクセスポイントは、これらの問題に対応するためのセキュリティの仕組みを持っていますので、無線 LAN 製品のセキュリティに関する設定を行って製品を使用することで、その問題が発生する可能性は少なくなります。セキュリティの設定を行わないで使用した場合の問題を充分理解した上で、お客様自身の判断と責任においてセキュリティに関する設定を行い、製品を使用することをお奨めします。

#### ■ Notice for users in Korea

**For models:** BCM92070MD\_REF, AR5B95, RT3090

Please note that this device has been certified for residential use and may be used in any environment.

**당해 무선설비는 운용중 전파혼신 가능성이 있음.**

**[It means that this wireless device may cause radio wave interference during operation]**

©Lenovo China 2010

New World. New Thinking.™  
[www.lenovo.com](http://www.lenovo.com)

**lenovo**™