

Paradigm[®] 522 and 722 Sensor Features

Caution - Investigational device. Limited by Federal law to investigational use.

© 2004, Medtronic MiniMed. All rights reserved.

This product is covered by U.S. Patent Nos. 6,551,276 and 6,554,798. Other U.S. and/or foreign patents may be pending.

Bolus Wizard™ is a trademark of Medtronic MiniMed.

Dual Wave™ is a trademark of Medtronic MiniMed.

Easy Bolus™ is a trademark of Medtronic MiniMed.

Square Wave™ is a trademark of Medtronic MiniMed.

BD Logic™ is a trademark of Becton, Dickinson and Company

Energizer® is a trademark of Eveready Battery Company.

Glucagon Emergency Kit® is a trademark of Eli Lilly and Company.

Paradigm® is a trademark of Medtronic MiniMed.

Paradigm Link™ is a trademark of Medtronic MiniMed.

The Link™ is a trademark of Becton, Dickinson and Company (Canada only)

Quick-serter® is a trademark of Medtronic MiniMed.

Quick-set® is a trademark of Medtronic MiniMed.

Silhouette® is a trademark of Medtronic MiniMed.

Sof-set® is a trademark of Medtronic MiniMed.

IV3000® is a registered trademark of Smith&Nephew, Inc.

Sen-serter® is a registered trademark of Medtronic MiniMed.

Guardian® is a registered trademark of Medtronic MiniMed.



Medtronic

MINIMED

Medtronic MiniMed

Northridge, CA 91325

USA

800-646-4633 (800-MiniMed)

818-576-5555

www.minimed.com

6025067-011 01/05

REF MMT-522

MMT-722

Chapter 1 Introduction	1
Assistance	1
Accessories	1
User safety	2
Indications	2
Contraindications	2
Warnings	2
Reservoir and infusion sets	2
X-rays, MRIs and CT scans	3
Transmitter	3
Precautions	3
Avoid extreme temperatures	3
Infusion sets and sites	3
Sensor	4
Adverse reactions	4
Notice	4
Insulin pump and Radio Frequency (RF) accessories	4
Chapter 2 Programming your sensor	7
Introduction	7
Sensor icons	7
Programming the sensor	8
High glucose alarm	8
High snooze feature	9
Low glucose alarm	9
Low snooze feature	10
Alarm snooze	10
Cal reminder	11
BG units	11
Transmitter ID	12
Missed data	13
Review settings	13

Chapter 3 Starting the sensor	15
Introduction	15
Inserting the sensor	15
The transmitter	20
Attaching the transmitter	20
Connecting the sensor to the transmitter	21
Starting the sensor	22
Enter meter BG	23
 Chapter 4 Using your sensor	 25
Status screens	25
Reading your graphs	26
Your glucose values	26
Your alarms	26
3 hour graph	27
24 hour graph	27
Sensor alarm history	28
Sensor update history	28
Review settings	29
Removing transmitter and sensor	30
Disconnecting the sensor from the transmitter	30
Removing the transmitter	30
Removing the sensor	30
Storage and handling	30
Sen-serter maintenance	30
 Chapter 5 Troubleshooting and alarms	 31
Alarms	31
What to do	32
Sensor alarm conditions	33
Troubleshooting	37
Reconnect old sensor	37
Find Lost Sensor	37
Icon table	38
Default settings	39

Thank you for choosing Medtronic MiniMed as your partner in helping you gain better control of your diabetes. The Paradigm® 522 and 722 pump combines the technology of the Guardian® Continuous Glucose Monitoring system as well as the Paradigm Link™ Blood Glucose Monitor powered by BD Logic™ Technology to provide not only insulin delivery but real-time glucose sensor values as well.

This user guide is designed to help you understand the sensor features of your pump. We strongly recommend that you work closely with your healthcare professional for a safe and complete pump start.

Assistance

Medtronic MiniMed provides a 24-hour Product Help Line for assistance. The Help Line is staffed with technicians who are trained in the set-up and operation of the pump and are able to answer pump-related questions. When calling the Help Line or your local Medtronic MiniMed office, please have your pump and serial number available. The phone number for the 24-hour Product Help Line is also on the back of your pump.

Department	Telephone number
24-hour Product Help Line (calls within the United States)	800.646.4633 (800.Minimed)
24-hour Product Help Line (calls outside the United States)	818.576.5555

Accessories

- ➔ **Meter:** Your pump can be used with the optional Paradigm Link™ Blood Glucose Monitor powered by BD Logic™ Technology. You can program your pump to automatically receive your blood glucose (BG) readings from this meter. When a BG reading is taken, the value is automatically transferred to the pump and stored in its memory as a calibration point. The calibration point is used to calculate the real-time sensor glucose values that are displayed. The data may then be downloaded to a computer.

- **Transmitter:** The transmitter (MMT-7701) is a small oval disk that connects to the sensor and is adhered to the skin with a medical dressing. It contains a battery, sensor electronics and a radio frequency transmitter. When a sensor is attached to the transmitter, it automatically initializes the sensor and begins to periodically transmit glucose data to the pump using a radio signal.
- **Sensor:** The glucose sensor (MMT-7002) is a device that continuously measures glucose from your subcutaneous tissue as an electronic signal, the strength of which is proportional to the amount of glucose present. An introducer needle allows for subcutaneous insertion of the sensor.
- **ComLink:** The Medtronic MiniMed ComLink (MMT-7304), if available, is used to download the pump data to the diabetes management software installed in your computer via a serial communications interface cable.

User safety

Indications

The Paradigm 522/722 pump system is indicated for the continuous delivery of insulin, at set and variable rates, for the management of diabetes mellitus in persons requiring insulin. In addition, the pump system is indicated for continuous periodic monitoring of glucose levels in the fluid under the skin, and possible low and high blood glucose episodes. The pump displays real-time glucose values and stores this data so that it can be analyzed to track patterns and improve diabetes management. Pump history can be downloaded to a computer for analysis of historical glucose values.

The real-time glucose values provided by the Paradigm 522 and 722 pump are not intended to be used directly for making therapy adjustments. Rather, they provide an indication that a confirmation fingerstick measurement may be required. All therapy adjustments should be based on measurements obtained using a home glucose monitor and not based on the value displayed by the Paradigm 522 and 722 pump.

Contraindications

Pump therapy is not recommended for people who are unwilling or unable to perform a minimum of four (4) blood glucose tests per day and to maintain contact with their healthcare professional. Successful insulin pump therapy requires sufficient vision or hearing to allow recognition of the pump signals and alarms.

Warnings

Reservoir and infusion sets

Use only the Paradigm reservoir and Paradigm infusion sets with your pump. The reservoir and infusion sets are specifically designed for use with the pump. Use of non Medtronic MiniMed Paradigm

reservoirs and/or infusion sets may reduce pump accuracy and hinder occlusion detection. Do not modify your Paradigm reservoir or Paradigm infusion set.

Do not put any other drugs/medications inside your reservoir to use with this pump. Only insulin that has been prescribed by your physician can be used in this pump.

X-rays, MRIs and CT scans

If you are going to have an X-ray, CT scan, MRI or other type of exposure to radiation, TAKE OFF YOUR PUMP, METER, TRANSMITTER, and SENSOR, and remove them from the area.

NOTE - The Paradigm pump and transmitter are designed to withstand common electromagnetic interference, including airport security systems.

Transmitter

The Transmitter should be removed if irritation or reaction to the Transmitter tape develops.

The Transmitter should be disconnected from the sensor while traveling on an aircraft, or if it interferes with another transmitting device.

Precautions

Although the pump has multiple safety alarms, it cannot notify you if the set is leaking or the insulin has lost its potency. **It is essential, therefore, that you test your blood glucose levels at least four times per day.** If your BG is out of range, check the pump and the infusion set to ensure that the necessary amount of insulin is being delivered.

Avoid extreme temperatures

- 1 Avoid exposure of your pump and remote control to temperatures above 108°F (42°C) or below 34°F (1°C).
- 2 Insulin solutions freeze near 32°F (0°C) and degrade at high temperatures. If you are outside in cold weather, wear your pump close to your body and cover it with warm clothing. If you are in a warm environment, take measures to keep your pump and insulin cool.
- 3 Do not steam, sterilize or autoclave your pump, transmitter, or sensor.

Infusion sets and sites

Avoid using an infusion site that will be irritated by clothing and accessories, or by rigorous stretching and exercise.

Sensor

Prior to exercising, make sure the sensor is firmly attached.

Adverse reactions

Operation of the sensor feature requires the insertion of a glucose sensor into the skin. Bleeding, swelling, bruising, or infection at the sensor insertion site are possible risks of sensor use. The sensor should be removed if redness, pain, tenderness or swelling develop at the insertion site. The transmitter should be removed if irritation or a reaction to the transmitter tape develops. Contact your doctor and the Medtronic MiniMed 24-Hour Product Help Line in the event of any adverse reaction.

Notice

CAUTION: Any changes or modifications to the devices not expressly approved by Medtronic MiniMed could void your ability to operate the equipment.

Insulin pump and Radio Frequency (RF) accessories

The pump, Paradigm Link meter, transmitter and remote control comply with the United States Federal Communications Commission and international standards for Electromagnetic Compatibility.

Do not use the RF meter or the transmitter to send your BG reading to the pump while on an aircraft. Manually enter your BG.

The transmitter should be disconnected from the sensor while traveling on an aircraft, or if it interferes with another transmitting device.

These devices comply with Part 15 of the FCC Rules. Operation is subject to the following two conditions: (1) This device may not cause harmful interference, and (2) this device must accept any interference received, including interference that may cause undesirable operation. It does not interfere with any radio frequency signals transmitted from outside sources.

These standards are designed to provide reasonable protection against excessive radio frequency interference and prevent undesirable operation of the device from unwanted electromagnetic interference. Operation is subject to the following two conditions:

- 1 This device has been tested and found to comply with the regulations governing such devices in your area. For the specific regulation and test results for your area, please contact the Medtronic MiniMed 24-hour Product Help Line.
- 2 This device generates, uses, and can radiate radio frequency energy and, if installed and used in accordance with the instruction, may cause interference to radio communications. If the device

does cause interference to radio or television reception, you are encouraged to try to correct the interference by one or more of the following measures:

- Reorient or relocate the insulin pump/remote control/Paradigm Link meter/transmitter
- Increase the separation between the insulin pump/remote control/Paradigm Link meter/transmitter and the device that is receiving/emitting interference

The Paradigm Link meter and transmitter sends information to the pump using radio frequency. If other devices that use radio frequency are in use, such as cell phones, cordless phones and wireless networks, they may prevent communication between the pump and the meter and/or the pump and transmitter. This interference will not cause any incorrect data to be sent and will not cause any harm to your pump, transmitter or meter. Moving away from or turning off these other devices may allow communication. Refer to, “Troubleshooting and alarms” in the pump user guide to correct interference problems you may have.

Wireless transmission between the pump and transmitter within the six-foot operating range may be interrupted due to the transmitter cable orientation. Move the pump closer to the transmitter or to another position. If a Lost Sensor alarm has occurred retry: **Sensor Start > Find Lost Sensor.**

If you have questions, please contact the Medtronic MiniMed 24-hour Product Help Line.

Introduction

This chapter describes how to program your pump to get it ready to accept sensor data. To understand how to navigate through these screens refer to your Pump User Guide. For your reference the sensor icons are described below.

Sensor icons

Using your pump - refer to the Pump User Guide (Paradigm 522/722 Infusion Pump User Guide) to learn how to navigate through the pump screens. There are various icons that appear at the top of your pump screen, like the time, battery and reservoir icons which are described in your pump user guide. The icons described here appear if you are using the sensor. Alert and Alarm icons have the same meaning as described in your pump user guide.

The sensor  icon appears once the Sensor feature is turned on.

The sensor  icon changes when the sensor is connected to the transmitter and communicating with the pump.

Programming the sensor

To set up the sensor feature, from the Home screen, press **ACT**, and do the following steps:

NOTE - The sensor features are programmed in the order described in this chapter.

Main Menu > Sensor > Sensor Setup > Edit Settings

1 Press **ACT**.

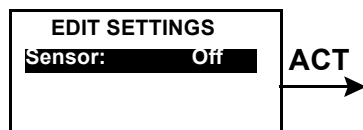

2 Select **On** and press **ACT**.

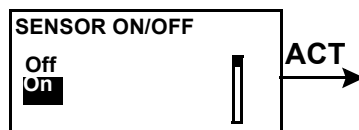

3 The **EDIT SETTINGS** screen will appear. Press **ACT** to program your High Glucose limit.

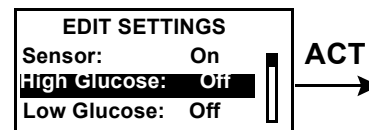

High glucose alarm

Your pump will alarm if your BG reaches or goes above what you set here. If you do not turn on the High Glucose Alarm your pump will not alarm when your BG goes high.

4 Select **On** and press **ACT**.

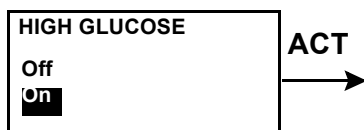

5 In the **SET HIGH GLUCOSE** screen, use the up and down arrow buttons to set your limit. Press **ACT**.

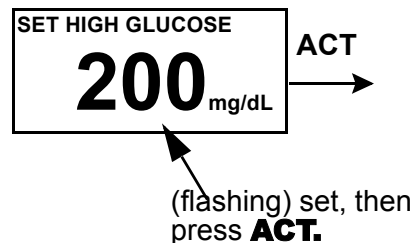

High snooze feature

Once you get a High Glucose Alarm, the pump alarms about every 5 minutes while the high glucose condition exists, unless you set the High Snooze feature. This allows your glucose to return to normal after you take some insulin without having the pump alarm about every 5 minutes. You can set the time period for between 5 minutes to 3 hours.

- 6 Press **ACT** to program the High Snooze feature.

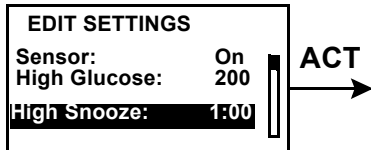

- 7 Use the up and down arrow buttons to select your High Snooze alarm time and press **ACT**.

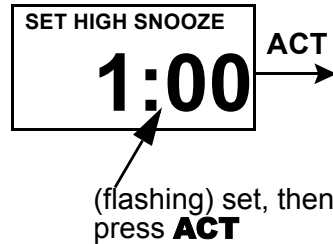

- 8 Press **ACT** to program your Low Glucose limit.

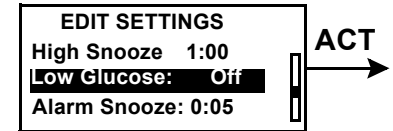

Low glucose alarm

Your pump will alarm if your BG reaches or goes below what you set here. If you do not turn on the Low Glucose Alarm, your pump will not alarm when your BG goes low.

- 9 Select **ON** and press **ACT**.

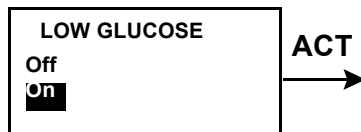

- 10 In the **SET LOW GLUCOSE** screen, use the up and down arrow buttons to set your low glucose limit and press **ACT**.

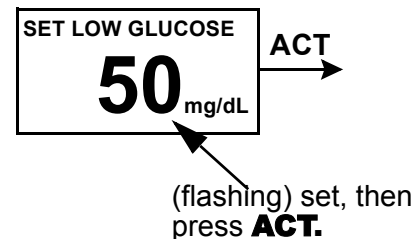

Low snooze feature

Once you get a Low glucose alarm, the pump alarms about every 5 minutes while the low glucose condition exists, unless you set the Low Snooze feature. This option can be turned on during a specific period of time when you are expecting your glucose level to fall below the set low limit. You can set the time period for between 5 minutes to 1 hour.

- 11** Low Snooze will be highlighted, press **ACT**.

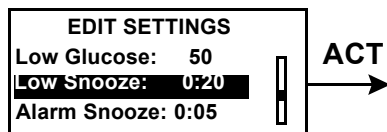

- 12** In the SET LOW SNOOZE screen, use the up and down arrow buttons to set the time for your Low Snooze alarm. Press **ACT**.

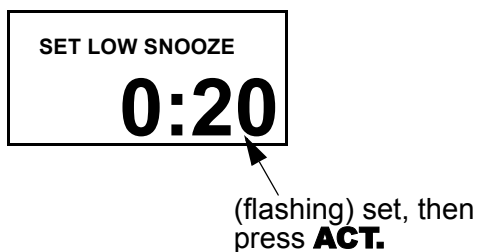

Alarm snooze

This option allows you to set an alarm snooze for the Meter BG Now alarm (see Chapter 5, Troubleshooting and Alarms for more information). So, instead of alarming every 5 minutes, they will alarm at the time interval you set here. For example, if you set an Alarm Snooze of 20 minutes for the Meter BG Now alarm, the alarm will only repeat every 20 minutes until you enter a Meter BG.

- 13** Alarm Snooze will be highlighted, press **ACT**.

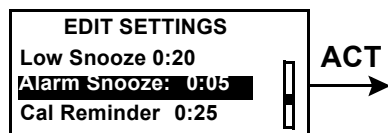

- 14** Use the up and down arrow buttons to set the Alarm Snooze. Press **ACT**.

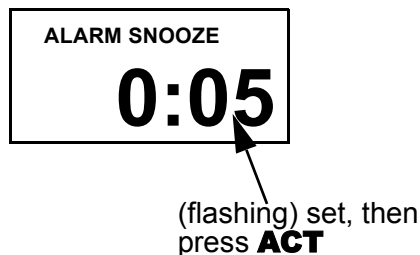

Cal reminder

To help you remember to enter your meter BG readings for sensor calibration you can set the Cal Reminder feature. To set your Cal Reminder:

15 Cal Reminder will be highlighted, press **ACT**.

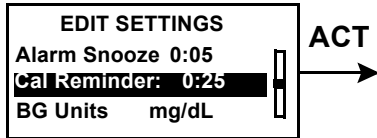

16 Use the up and down arrow buttons to set the time and press **ACT**.

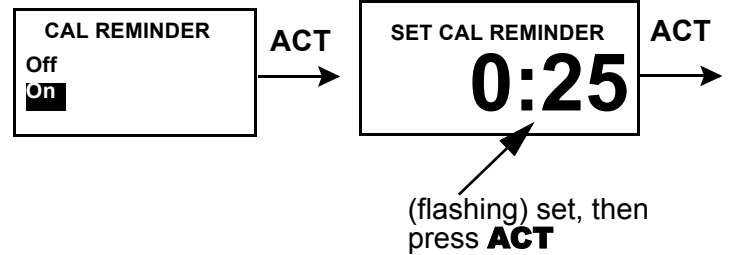

BG units

You can select mg/dL or mmol/L as your Blood Glucose Unit (measurement type).

NOTE - This menu option will not appear if the Bolus Wizard feature is on.

17 BG Units will be highlighted, press **ACT**.

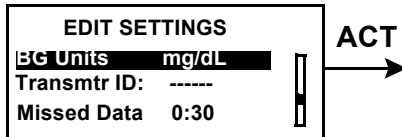

18 Select mg/dL or mmol/L and press **ACT**.

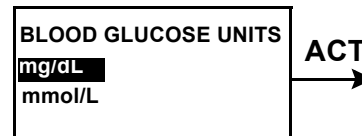

Transmitter ID

The transmitter ID is found on the back of your transmitter. You need to enter your transmitter ID so the transmitter and pump can communicate with each other.

19 Select Transmtr ID and press **ACT**.

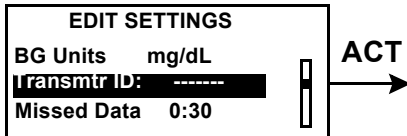

20 Use the up and down arrow buttons to select each of the seven ID numbers. Press **ACT** after each entry. Press **ESC** when you are done.

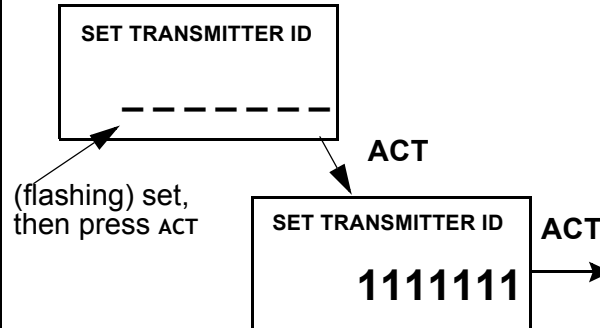



Tip - To remember your transmitter ID, write it down here _____.

21 The EDIT SETTINGS screen will appear. Your Transmitter ID will be highlighted.

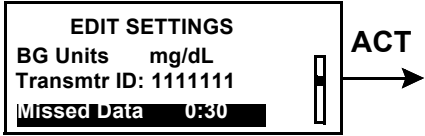

Missed data

The Missed Data feature allows you to set the period of time the pump will wait to alert you to failed reception of sensor data from the transmitter to the pump.

<p>22 Select Missed Data and press ACT.</p>  <p>EDIT SETTINGS BG Units mg/dL Transmtr ID: 1111111 Missed Data 0:30</p> <p>ACT</p>	<p>23 Use the arrow buttons to set the time, Press ACT.</p>  <p>SET MISSED DATA 0:30</p> <p>ACT</p> <p>(flashing) set, then press ACT</p>	<p>24 When you have completed the sensor setup, press ESC until the HOME screen appears.</p>
---	---	--

Review settings

Main Menu > Sensor > Sensor Setup > Review Settings

The Review Settings feature allows you to review your settings to verify that they have been set as you intended.

Select Review Settings now and verify that your settings are correct.

REVIEW SETTINGS	
Sensor:	On
High Glucose	200
High Snooze	1:00
Low Glucose:	50
Low Snooze	0:20
Alarm Snooze	0:05
Cal Reminder	0:25
BG Units:	mg/dL
Transmtr ID:	1111111
Missed Data	0:30

Introduction

To start the sensor working you must complete the following steps in order.

- ➔ Insert the sensor
- ➔ Apply the transmitter
- ➔ Connect the sensor to the transmitter
- ➔ Perform “Sensor Start” on the pump

Inserting the sensor

The sensor is inserted through the skin with an insertion device called the Sen-serter® and placed in the subcutaneous tissue. The sensor produces a signal that is proportional to the concentration of glucose in the interstitial fluid at the insertion site. This signal is sent to the transmitter, which is then sent to the pump. The pump translates the signal and displays a sensor reading on your pump screen.

Choose a site with adequate subcutaneous fat for sensor insertion. Shown below are the body areas (shaded) that are best for sensor insertion.

CAUTION: Never insert the sensor within 2 inches from the pump infusion site or within 3 inches from the manual injection site.

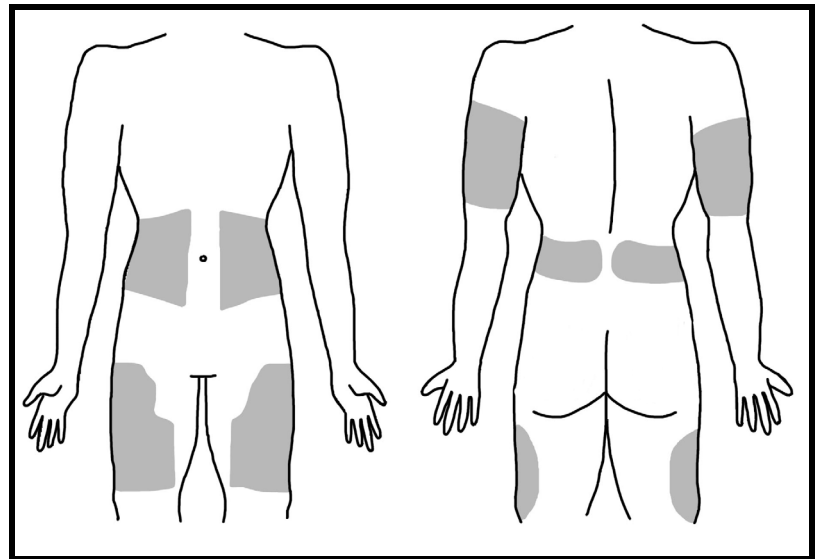

Areas to avoid:

- Frequently used injection or pump/sensor sites
- Belt or waistline
- 2-inch area around navel
- Site where clothing will rub or constrict
- Scarred or atrophied tissue
- Areas subjected to rigorous movement
- Never insert the sensor within 2 inches from the pump infusion site or within 3 inches from the manual injection site.

NOTE - Clean site with alcohol, making sure site is dry before inserting the sensor. Do NOT use skin-preparation solutions prior to insertion. However, I.V. Prep may be used after insertion and before applying a sterile dressing. Lift back of tape slightly to apply I.V. Prep.

Always refer to the instructions that shipped with your glucose sensor.

1 Wash your hands.

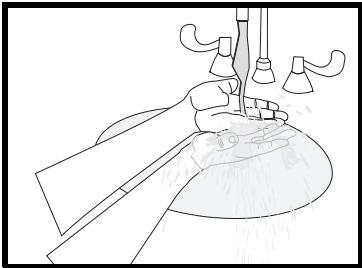

2 Clean and dry the sensor site.

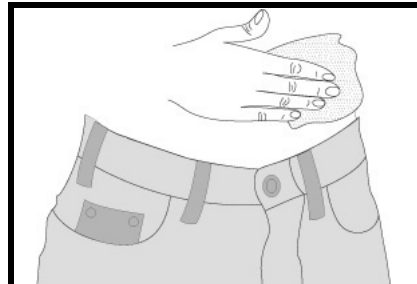

- 3** Remove the sensor from package by holding base or tape. Do not hold the sensor by the introducer needle handle.

- 4** Place the sensor in the Sen-serter® until it fits snugly.

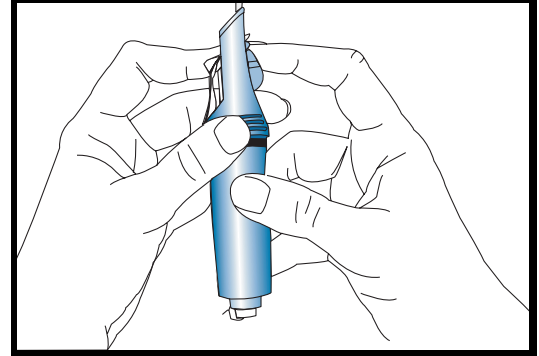

- 5** Place fingers on the back of the white tape and push the carrier down until it clicks into place.

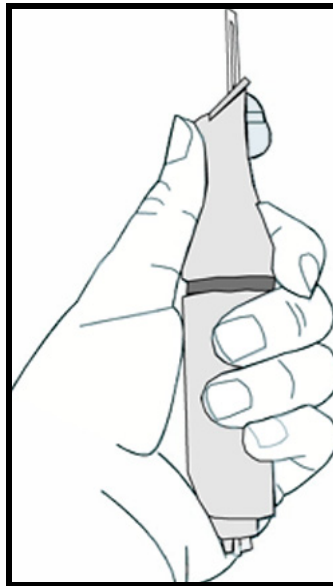

- 6** Holding the white tape as shown, remove the clear tape using a counterclockwise motion.

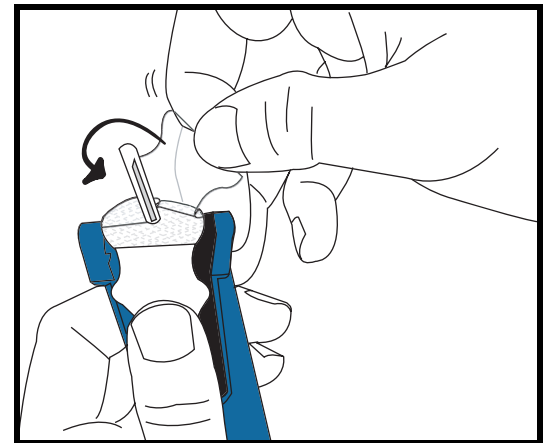

- 7** Turn the lock and remove needle guard from introducer needle.

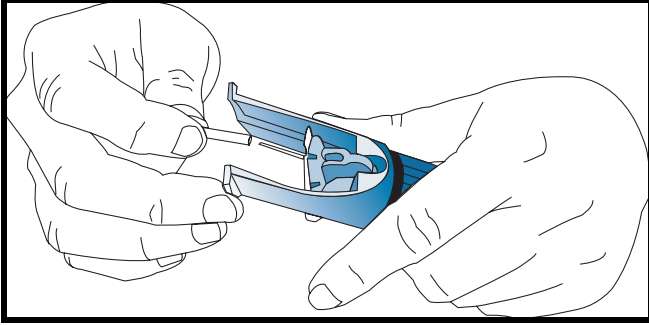

- 8** Rest the Sen-serter legs on skin at 45 degree angle, placing two fingers of opposite hand on the Sen-serter legs to maintain angle.

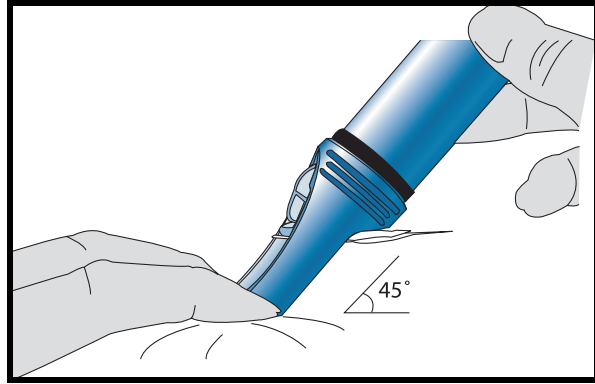

- 9** Press the white button to insert the sensor.

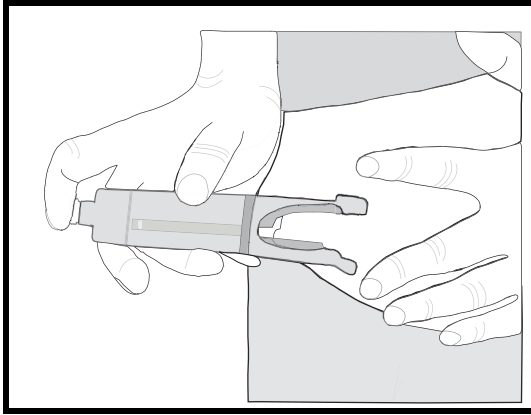

- 10** Make sure the sensor is inserted and flush with your skin.

- 11** While holding the sensor in place, gently slide the Sen-serter away from the sensor. Do not twist, bend or lift the Sen-serter while removing from the sensor.

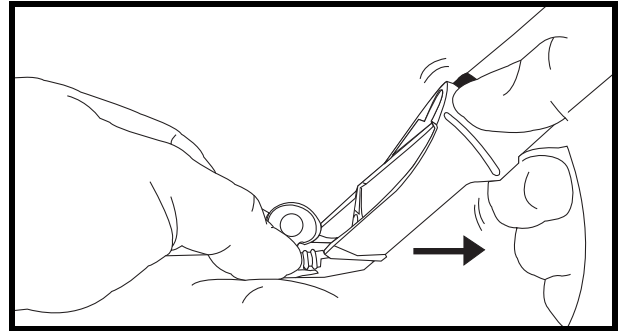

- 12 Holding the sensor base, remove the white paper from the adhesive pad. Press adhesive against your skin.

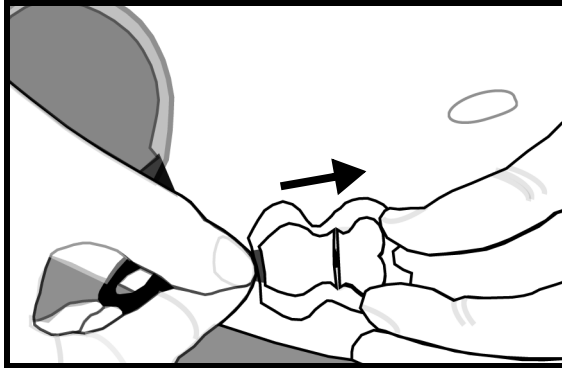

- 13 Hold the sensor with two fingers on the base, and gently remove the introducer needle at a 45-degree angle. Do NOT rotate introducer needle when removing. Dispose of needle in sharps container.

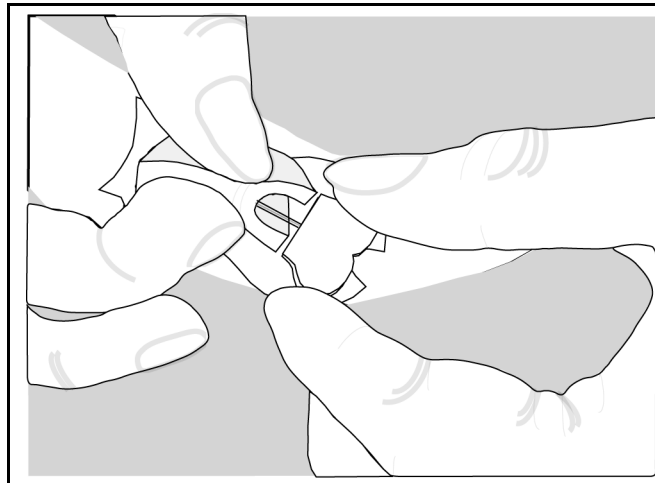

NOTE - *Bleeding will not affect the sensor's performance.*

- 14 Check the site for redness, bleeding, irritation, pain, tenderness or inflammation.

The transmitter

The Medtronic MiniMed Transmitter (MMT-7701) is a device that takes electronic signals generated by the glucose sensor and sends them by radio frequency to the pump. The transmitter is attached to the sensor by a sensor connector.

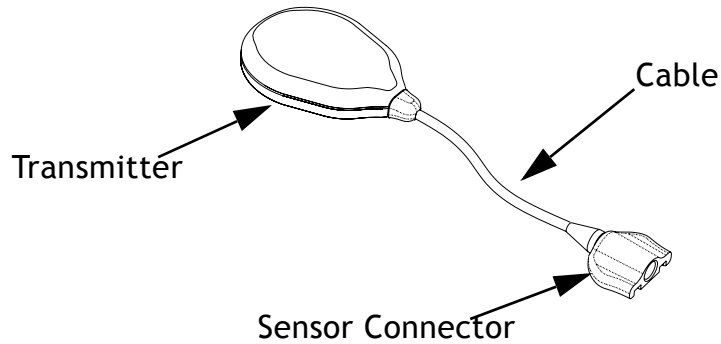

Attaching the transmitter

- 1 Find a comfortable, protected area on the abdomen that is within cable reach to the sensor.
- 2 Clean the area with isopropyl alcohol and allow to dry.
- 3 Peel the paper from the Transmitter side of the adhesive pad.
- 4 Stick the adhesive pad to the back of the Transmitter.
- 5 Peel the paper from the skin side of the adhesive pad. Apply to skin by pressing firmly.

Connecting the sensor to the transmitter

CAUTION: In order to avoid damage, make sure the sensor and the cable are level when attaching.

- 1 Hold the sensor base while connecting the cable. Do not squeeze clips. You should hear a click when the cable and sensor connect. You will also hear a short beep from the transmitter.

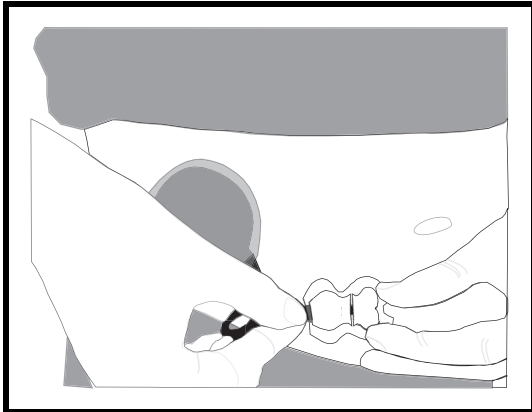

- 2 A prepping agent, such as an I.V. Prep may be used to strengthen adhesion before applying sterile dressing. Make sure smooth side is down. The cable may be looped under tape for strain relief. Apply a sterile, transparent dressing such as an IV3000® tape, over site.

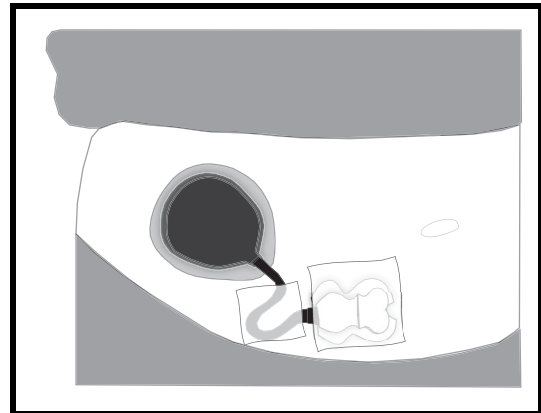

Starting the sensor

You are now ready to start your sensor so the sensor and the pump can communicate with each other. To do this, follow the steps below:

- 1 Press **ACT** from the HOME screen. In the MAIN MENU, select **Sensor** and press **ACT**.

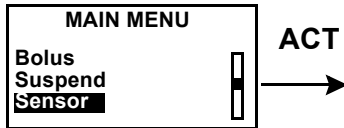

- 2 Select **Sensor Start**, press **ACT**.

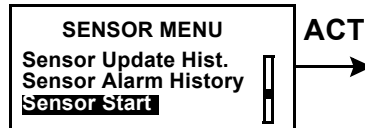

- 3 **New Sensor** will be highlighted, press **ACT**.



NOTE - If screen times out, start again, **DO NOT** disconnect sensor.

- 4 Connect your sensor now if you have not already done so. Press **ACT**.

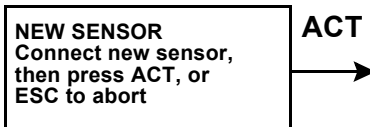

- 5 Press **ACT**.

SENSOR READY 2 HRS
Alert will sound when
meter BG is required.
Press any key to cont.

Enter meter BG

After the two hour initialization period you must enter a BG reading into the pump to calibrate the sensor. If you are using the Paradigm Link this will be done automatically with each fingerstick. To enter a value manually perform the following steps.

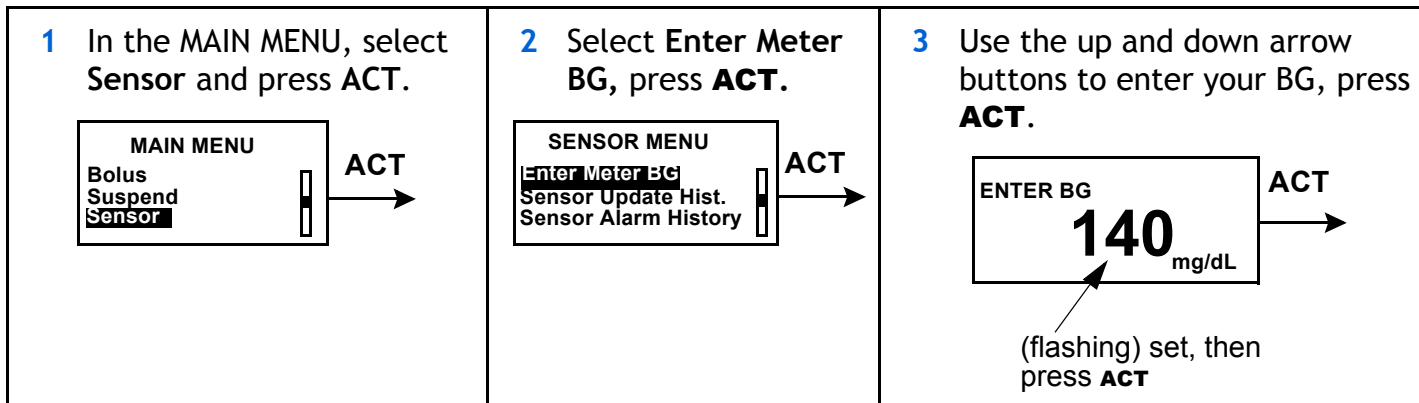

Status screens

Your STATUS screens tell you what is going on in your pump. In the SENSOR STATUS screen you can check the status of sensor information including when your next calibration will be needed, your sensor's age, and the state of your transmitter battery.

To get to your status screens:

- 1 From the HOME screen, press the **ESC** button three times. This takes you to your pump status screen.

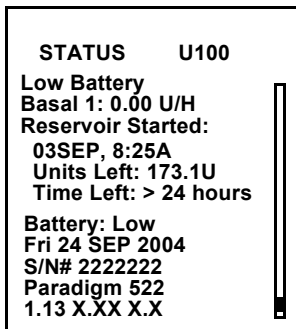

STATUS U100
Low Battery
Basal 1: 0.00 U/H
Reservoir Started:
03SEP, 8:25A
Units Left: 173.1U
Time Left: > 24 hours
Battery: Low
Fri 24 SEP 2004
S/N# 2222222
Paradigm 522
1.13 X.XX X.X

- 2 To see the **Sensor Status** screen, press **ESC** one more time.

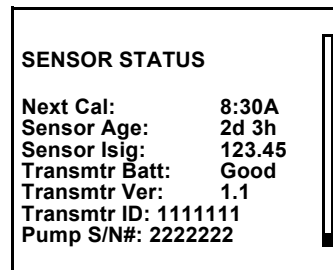

SENSOR STATUS
Next Cal: 8:30A
Sensor Age: 2d 3h
Sensor Isig: 123.45
Transmtr Batt: Good
Transmtr Ver: 1.1
Transmtr ID: 1111111
Pump S/N#: 2222222





The Sensor Status screen will only be available if the sensor feature has been turned on.

Reading your graphs

Once the sensor is calibrated you can view your sensor glucose values in real-time. To view your current glucose and the most recent three hours of data press **ESC** once from the home screen, to view the most recent 24 hours of data press **ESC** twice from the home screen.

Your glucose values

Your glucose value will be shown on your graph. Each data point on the graph indicates your sensor glucose. If an arrow is next to your sensor glucose:

- An up arrow  next to your glucose indicates that your glucose is rising at a rate of 1 to 2mg/dL per minute for the last 20 minutes. Your glucose has changed by 20-40 mg/dL in the last 20 minutes.
- A down arrow  next to your glucose indicates that your glucose is dropping at a rate of 1 to 2mg/dL per minute for the last 20 minutes. Your glucose has changed by 20-40 mg/dL in the last 20 minutes.
- Two up arrows  next to your glucose indicates that your glucose is rising at a rate of more than 40 mg/dL over the last 20 minutes.
- Two down arrows  next to your glucose indicates that your glucose has been dropping at a rate of more than 40 mg/dL over the last 20 minutes.

Your alarms

The graph will also show any alarms that you received along with the time of the alarm. The alarms you will see in your graph screens are:

➤ Meter BG	➤ Sensor End	➤ Sensor Error	➤ Lost Sensor
➤ Cal Error	➤ Bad Sensor	➤ Weak Signal	

For further information on these alarms, go to Chapter 5, Troubleshooting and Alarms.

3 hour graph

To scroll through your sensor glucose data points and any alarms that you may have received press the down button. Below is an example along with explanations of a screen you may see

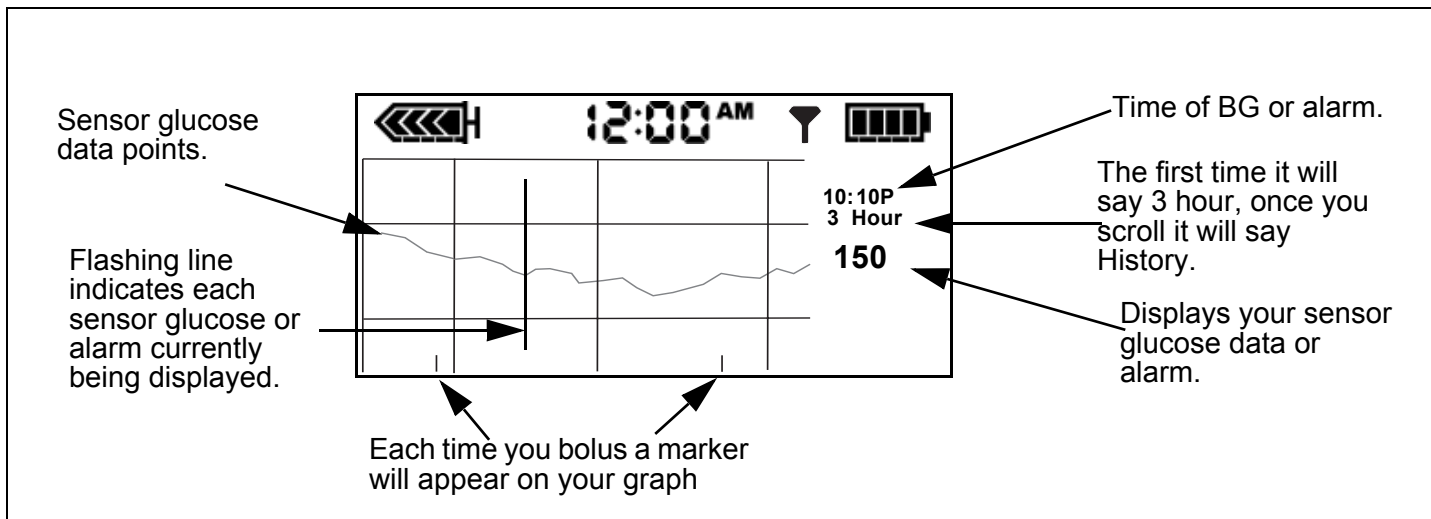

24 hour graph

To view the current glucose and a graph of the most recent 24 hours of data, from the HOME screen, press **ESC** twice:

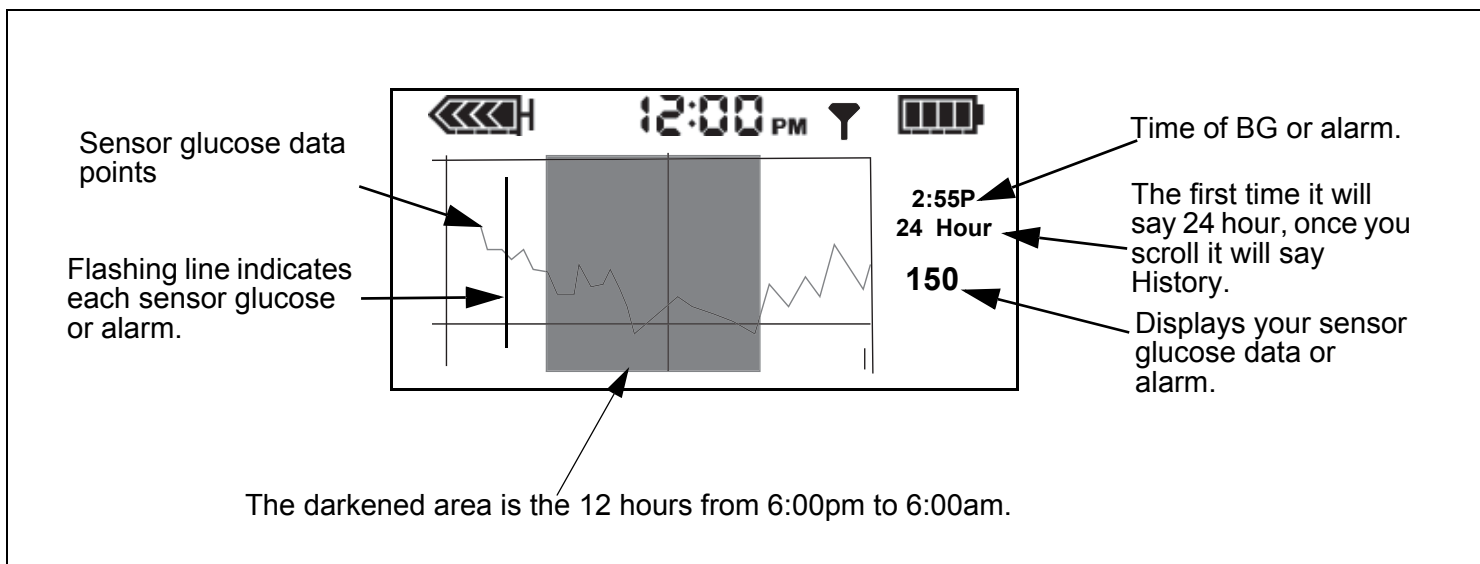

Sensor alarm history

Lists all of the sensor alarms that have occurred and will display up to 36 alarms. To view your Sensor Alarm History:

- 1 In the MAIN MENU, select **Sensor** and press **ACT**.

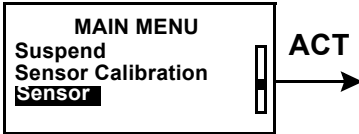

- 2 Select **Sensor Alarm History**, press **ACT**.

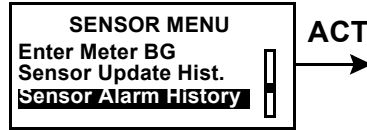

- 3 The **SENSOR ALARM HISTORY** screen will appear.

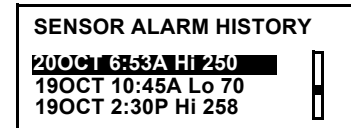

Sensor update history

Lists all your calibration values entered into the pump. To view your Sensor Update History:

- 1 In the MAIN MENU, select **Sensor** and press **ACT**.

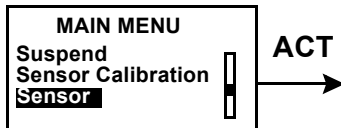

- 2 Select **Sensor Update Hist.**, press **ACT**.

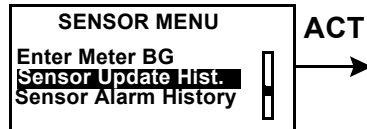

- 3 The **SENSOR UPDATE HISTORY** screen will appear.

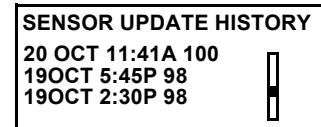

Review settings

To review your sensor settings:

- 1 In the MAIN MENU, select **Sensor** and press **ACT**.

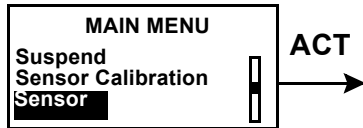

- 2 Select **Sensor Setup**, press **ACT**.



- 3 Select **Review Settings**, press **ACT**.

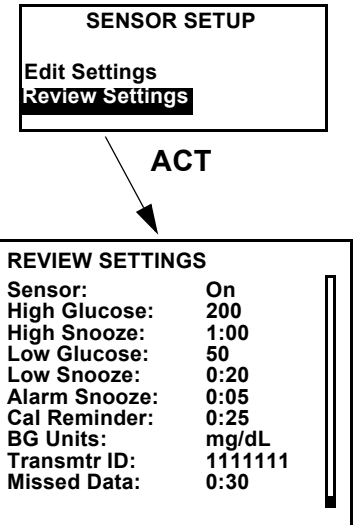

NOTE - If you do not turn on the High Glucose or the Low Glucose alarms then you will not see High Snooze or Low Snooze listed under Review Settings.

Removing transmitter and sensor

Disconnecting the sensor from the transmitter

Hold the glucose sensor assembly in one hand and the sensor connector in the other hand. While pinching the snap arms on the sides of the glucose sensor assembly together, gently pull the glucose sensor assembly away from the sensor connector.

Removing the transmitter

Remove by pulling gently on the transmitter. Do not pull off by the sensor connector wire.

Removing the sensor

Remove the outer tape from over the sensor. Gently pull the sensor from your body. When removed place in a sharps container.

Storage and handling

Store sensors in refrigerator at +2 to 10°C (+36 to +50° F). Do not freeze.

Prior to opening, allow the sensor package to reach room temperature and 5% to 95% humidity to prevent condensation.

Sen-serter maintenance

Cleanse Sen-serter with soapy water, using liquid detergent or other household soaps. Allow to dry.

Disinfect Sen-serter by wiping with 10% bleach solution or 70% isopropyl alcohol.

Store Sen-serter in the released position to maintain optimum product performance and life.

Alarms

Your pump has a sophisticated network of safety checks and systems. If the safety network detects anything unusual, your pump notifies you of conditions that require your immediate attention. The backlight illuminates the pump screen, and the alarm message displays on the screen. Alarms put the pump in “Attention” mode.

NOTE - The STATUS screen shows any alarms that are active.

► Why are alarms important?

Your pump monitors activities and notifies you if there is an unusual pump status or your attention is required.

An alarm gradually becomes higher in volume until you turn it off. If the vibrate mode is on, all alarms start as vibrations and then change to beeps. For your safety, if there is no response within ten (10) minutes, the beeps change to a siren. The pump will alarm with a siren and/or a vibration every minute until the alarm is cleared.

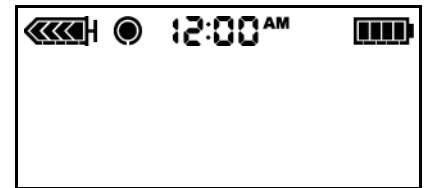

when a solid circle appears,
follow the instructions on the
screen.

What to do

When an alarm is triggered, the pump goes into Attention mode, and an alarm message shows on the screen. The pump then defaults to the HOME screen. Do these steps when you get an alarm:

1 View the alarm:

From the HOME screen, press any button to see the alarm message.

2 Read all of the alarm text. There are instructions on how to fix the alarm condition. (Press  to read more text, if available.)

3 Clear the alarm:

Press **ESC** then **ACT** after you read the alarm instructions.

4 The HOME screen appears.

5 Follow the instructions that appeared with the alarm to fix the alarm condition.

6 Check your settings (i.e., time/date, basal, etc.) to make sure they are correct.



Sensor alarm conditions

Listed below are the alarms that you may encounter while using the sensor feature of your pump, along with how to resolve the alarm condition.

Weak signal

Alerts you when the pump does not receive valid data for a period of time, as set in Missed Data. Move the pump to a new location on your body.

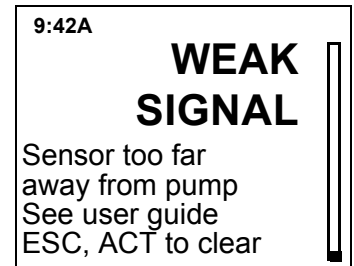

Lost sensor

The pump has not received a signal from the transmitter for more than 40 minutes. Make sure the transmitter and sensor are connected. If you hear a beep you will have to recalibrate. **Do NOT disconnect.** To find your sensor use the **Find Lost Sensor** function:

Main Menu > Sensor > Sensor Start > Find Lost Sensor

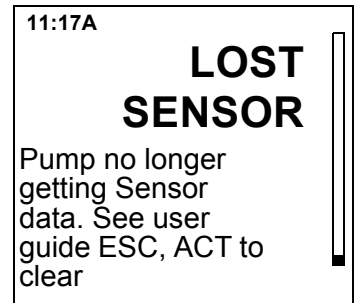

Low transmtr

Occurs when the transmitter battery is low. Replace transmitter. Need to order new transmitter.

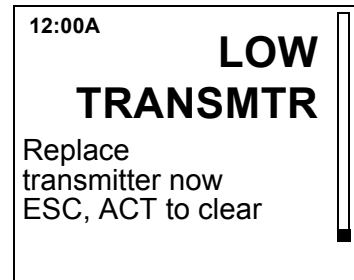

Bad transmtr

The transmitter battery is depleted. Replace transmitter.

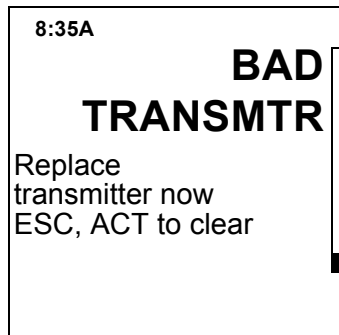

Bad sensor

The transmitter has detected a bad sensor. Replace Sensor.

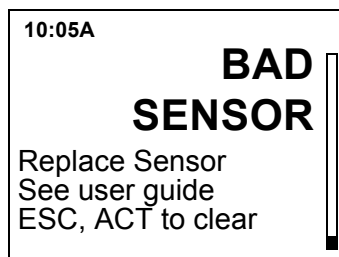

Sensor End

The sensor has reached the end of its life. Replace sensor. The sensor has a life of about 72 hours which is about 3 days.

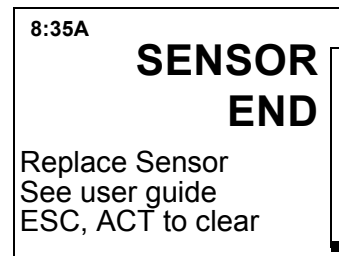

Cal error

Enter a new meter BG and try again. If error repeats, wait 10-15 minutes and try again. If error repeats replace sensor.

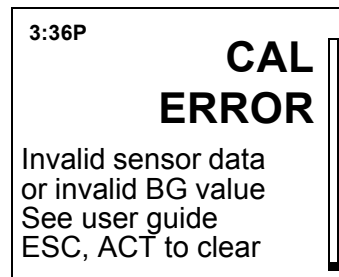

Meter BG now

A meter BG is needed right away to update sensor and to keep receiving sensor glucose data.

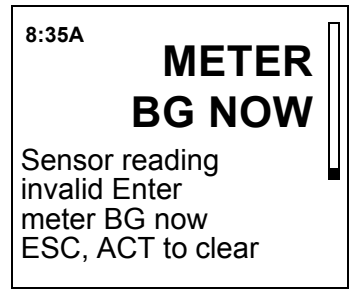

Meter BG by

A meter BG entry is required by the time that is shown to update sensor and to keep receiving sensor glucose data.

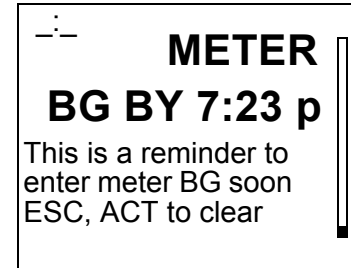

Low mg/dl

The glucose value is lower than or equal to the low glucose limit set. If you do not set a Low BG then you will not get a Low BG alarm.

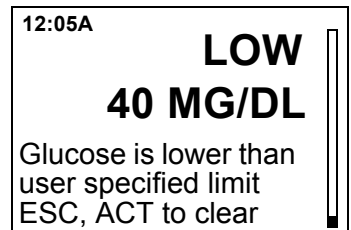

High mg/dl

The glucose value is higher than or equal to the high glucose limit set. If you do not set a High BG then you will not get a High BG alarm.

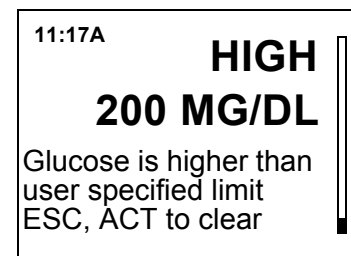

Sensor error

Sensor failed self-test. Press **ESC** then **ACT** to clear. You do not need to change the Sensor. If the sensor fails self-test a second time you will get a Bad Sensor alarm. If that occurs you will need to replace the sensor.

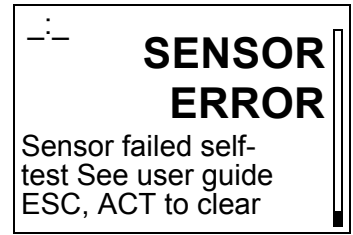

Troubleshooting

Reconnect old sensor

You should only use this feature if you have disconnected the sensor and transmitter and have to reconnect. For example, when flying on an aircraft.

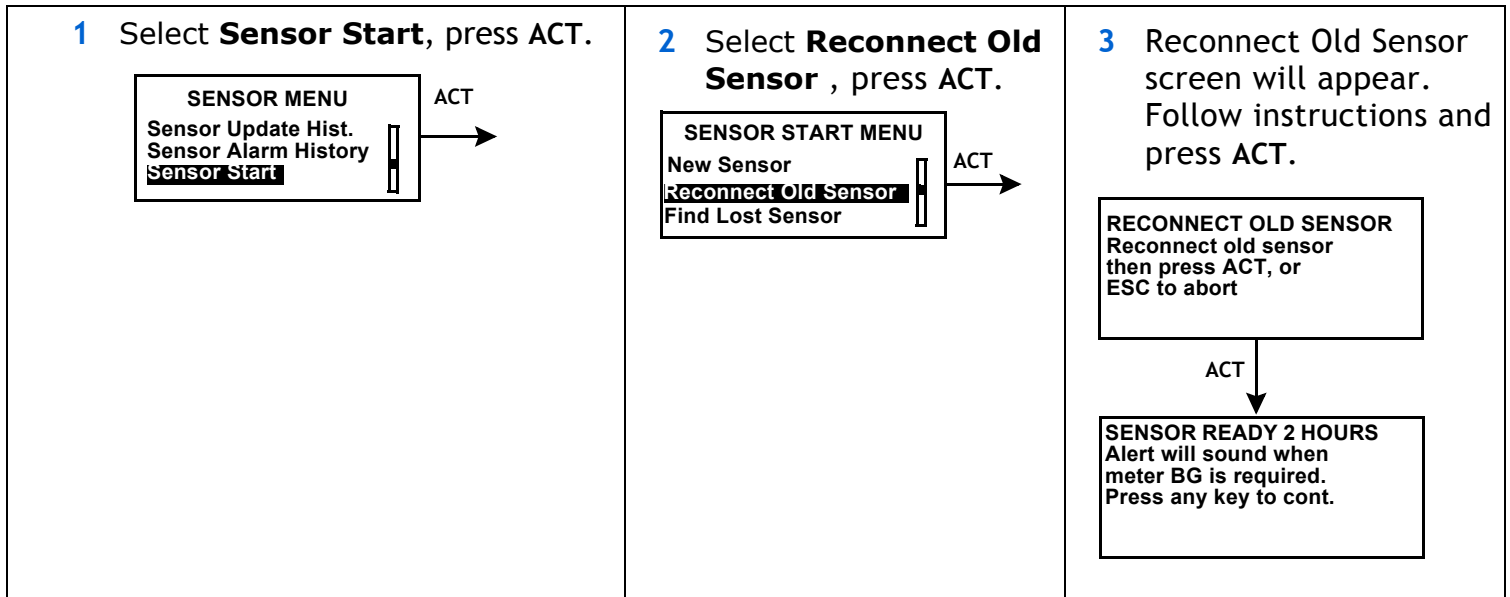





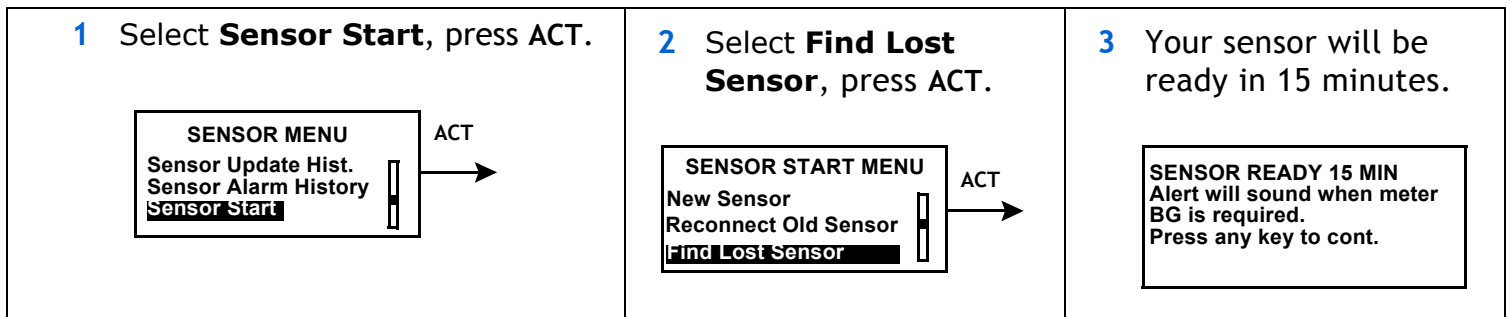





Find Lost Sensor

If you receive a Lost Sensor alarm:



Icon table

Do not reuse:	
Attention: See Instructions for Use	
Method of sterilization using ethylene oxide:	STERILE EO
Date of manufacture (year - month):	
Batch code:	LOT
Use by: (year - month)	
Catalogue number:	REF
Device serial number:	SN
Storage temperature range:	
Fragile product:	
Type BF equipment: (Protection from electrical shock)	
Pump: Conforms to IEC60601-1 sub-clause 44.6 and IEC60529 standard.	IPX7
Transmitter: Protected Against the Effects of Continuous Immersion in Water.	IPX8
Country:	
Language of Instructions for Use:	
Recycle:	



Default settings

Menu	Item	Default Setting	Limits
Sensor Menu:	Sensor:	Off	
	High Glucose:	Off	Low-400*
	Low Glucose:	Off	40-Hi*
	Alarm Snooze:	Off	0:05-1:00
	BG Units:	mg/dL	
	Cal Reminder	Off	0:05-4:00
	Missed Data	0:20	0:05-0:40
	Low Snooze	0:20	0:05-1:00
	High Snooze	1:00	0:05-3:00

*Depending on your settings for High and Low Glucose, your limit ranges will vary.

A

Alarm Snooze - Once a sensor alarm occurs the pump will not repeat the alarm until after this period of time. This is the setting for the Meter BG Now alarm.

B

BG Units - Blood glucose units used by the pump (mg/dL or mmol/L). The BG units can only be set from the sensor “Edit Settings” screen if the Bolus Wizard is turned off.

C

Cal Reminder - The pump will trigger a Meter BG Now alarm automatically every 12 hours, signaling that the current calibration value is no longer valid. The value of the Cal Reminder is the amount of time before the current calibration value expires when the user wants to be reminded to calibrate by having the pump issue a Meter BG Now alarm. For example, if the Cal Reminder is set to 2 hours, the Meter BG Now alarm will occur 2 hours before the calibration is required.

H

High Glucose - The pump will alarm if the sensor indicates that the user’s blood glucose is at or

above this value. You have the option to turn this feature on or off.

High Snooze - Allows the user to set the delay between the first High Glucose Alarm and any subsequent alarms. This will allow the user to avoid an alarm every five minutes until the condition is corrected.

L

Low Glucose - The pump will alarm if the sensor indicates that the user’s blood glucose is at or below this value. You have the option to turn this feature on or off.

Low Snooze - Allows the user to set the delay between the first Low Glucose Alarm and any subsequent Low Glucose Alarms. This will allow the user to avoid an alarm every five minutes until the condition is corrected.

M

Missed Data - The pump will alarm if it has not received data from the sensor for an amount of time that you set.

P

Pump S/N - Pump S/N is the serial number of the pump currently in use.

S

Sensor - Indicates whether the sensor feature is On or Off.

Sensor Age - Sensor age is the amount of time, in days and hours, since the sensor was first inserted.

Sen-serter - The Sen-serter is indicated as an aid for insertion of the Medtronic MiniMed glucose sensor.

T

Transmtr Batt - The status of the transmitter battery. Possible values are “Good,” “Low,” or “Bad.”

Transmtr ID - The serial number of the transmitter currently in use.

Transmtr Ver - The software version of the transmitter currently in use.

Numerics

24-Hour Product Help Line, contacting 1

A

Accessories 1
 ComLink 2
 meter 1
 sensor 2
 transmitter 2
 Adverse reactions 4
 Aircraft
 flying with pump
 FCC radio frequency rules 4
 Alarm history
 viewing for sensor 28
 Alarm Snooze
 setting 10
 Alarms
 bad sensor 34
 bad transmtr 34
 cal err 34
 conditions for receiving 33
 high mg/dL 35
 how to respond 32
 lost sensor 33
 low mg/dL 35
 low transmtr 33
 meter BG by 35
 meter BG now 35
 sensor end 34

 sensor error 36
 understanding 31
 weak signal 33
 Assistance
 24-Hour Product Help Line 1
 Avoiding an insertion site 16

B

Bad sensor alarm 34
 Bad transmtr alarm 34
 BG
 24 hour graphs 27
 3-hour graphs 27
 values in graphs 26
 BG units 9

C

Cal 34
 Cal err alarm 34
 Calibration reminder
 setting a Cal Reminder 11
 Choosing an insertion site 15
 Contraindications 2

F

FCC compliance
 Part 15 of FCC Rules 4
 Flying on an aircraft
 FCC radio frequency rules 4

G

Graphs
 24 hour 27
 3 hour 27
 sensor 26

H

Help Line, contacting 1
 High Glucose alarm
 setting 8
 High mg/dL alarm 35
 High snooze alarm
 setting 9
 History
 review settings 29
 sensor alarm, viewing 28
 sensor updates, viewing 28

I

Icons on the pump
 sensor communicating 7
 sensor on 7
 Indications 2
 Inserting the sensor 15
 choosing a site 15
 Sen-serter 15
 sites to avoid 16

L

- Lost sensor alarm 33
- Lost sensor data
 - Missed Data feature 13
- Low 33
- Low Glucose alarm
 - setting 9
- Low mg/dL alarm 35
- Low snooze alarm
 - setting 10
- Low transmtr alarm 33

M

- Meter 1
- Meter BG by alarm 35
- Meter BG now alarm 35
- Missed Data feature
 - setting 13

N

- Notice
 - radio frequency and FCC compliance 4

P

- Precautions
 - extreme temperatures 3
 - infusions sets and sites 3
 - sensor 3
- Pump
 - alarms
 - how to responds 32
 - setting up Sensor feature 7
 - status screens 25

- turning Sensor feature on 7
- Pump icons
 - sensor communicating
 - Sensor on
 - how to know 7
 - sensor on 7

R

- Radio frequency
 - FCC rules and compliance 4
- Review Settings
 - viewing for sensor 29
- RF features,
 - Paradigm Link meter 1

S

- Sen-serter 15
- Sensor
 - 24 hour graphs 27
 - 3 hour graphs 27
 - Alarm History, viewing 28
 - Alarm Snooze 10
 - alarms
 - bad sensor 34
 - bad transmtr 34
 - cal err 34
 - conditions for receiving 33
 - high mg/dL 35
 - how to respond 32
 - lost sensor 33
 - low mg/dL 35
 - low transmtr 33
 - meter BG by 35
 - meter BG now 35
 - sensor end 34
 - sensor error 36
 - understanding 31

- weak signal 33
- calibration reminder
 - setting Cal Reminder 11
- graphs 26
- High Glucose alarm 8
- High snooze alarm 9
- icons
 - sensor communicating 7
 - sensor on 7
- Low Glucose alarm 9
- Low snooze alarm 10
- Missed Data feature
 - loss of sensor data 13
- Review Settings 29
- setting up feature on pump 7
- startup procedure list 15
 - inserting the sensor 15
 - choosing a site 15
 - Sen-serter 15
 - sites to avoid 16
 - status screens 25
 - Transmitter ID 12
 - turning feature on 7
 - Update History, viewing calibration values 28
- Sensor communicating
 - how to know 7
- Sensor End alarm 34
- Sensor error alarm 36
- Site
 - avoiding insertion in 16
 - choosing for insertion 15
- Snooze alarms
 - setting 10
- Start sensor
 - procedure list 15
 - inserting the sensor 15
 - choosing a site 15
 - Senserter 15

sites to avoid 16

Status screens

 pump 25

 sensor 25

storage temperature, pump 38

supplies, ordering 2

T

Transmitter ID

 setting 12

U

Update history

 viewing sensor calibration

 values 28

User Safety

 adverse reactions 4

 contraindications 2

 indications 2

 precautions 3

UserSafety

 warnings 2

W

Warnings

 reservoir and infusion sets 2

 transmitter 3

 X-rays, MRIs and CT scans 3

Weak signal alarm 33

