



**Medtronic**

---

24965

Patient Connector

**DRAFT**

Technical Manual

---

**Caution:** Federal law (USA) restricts this device to sale by or on the order of a physician.

The following list includes trademarks or registered trademarks of Medtronic in the United States and possibly in other countries. All other trademarks are the property of their respective owners.

CareLink, Medtronic













# Contents















<b>1</b>	<b>Introduction to the 24965 Patient Connector</b>	<b>4</b>
1.1	Explanation of packaging and product symbols	4
1.2	Description	5
1.3	Intended use	6
1.4	Contraindications	6
1.5	Warnings	6
1.6	Precautions	7
1.7	Regulatory compliance	8
1.8	Patient Connector functions	8
1.9	Security	8
1.10	Compatible components	9
<b>2</b>	<b>Setup and configuration</b>	<b>9</b>
2.1	System components	9
2.2	Setup	11
<b>3</b>	<b>Conducting a patient session</b>	<b>14</b>
3.1	Position the patient connector	14
3.2	Communicating with an implanted device	14
<b>4</b>	<b>Maintaining the patient connector</b>	<b>14</b>
4.1	Cleaning and disinfecting the 24965 Patient Connector	14
4.2	Software updates	15
4.3	Specifications	15

# 1 Introduction to the 24965 Patient Connector

## 1.1 Explanation of packaging and product symbols

Refer to the package label and product to see which symbols apply to this product.

	Caution
	Consult instructions for use
<b>IP22</b>	Ingress protection
	Use only with specified power supply
	Type BF applied part
	Humidity limitation
	Non-ionizing electromagnetic radiation
	Do not dispose of this product in the unsorted municipal waste stream. Dispose of this product according to local regulations. See <a href="http://recycling.Medtronic.com">http://recycling.Medtronic.com</a> for instructions on proper disposal of this product.
	Direct current
	Manufacturer
	Date of manufacture
<b>REF</b>	Re-order number
<b>SN</b>	Serial number
	Package contents
	Product documentation

	Accessories
	China RoHS
	Bluetooth connection
	Follow instructions for use (blue)
	Low battery
	Keep dry
	ACMA (Australian Communications and Media Authority and the New Zealand Ministry of Economic Development Radio Spectrum Management standards) symbol for Australia and New Zealand
	For US audiences only
	ETL Listed Mark
	Technical Conformity (Ministry of Internal Affairs and Communications) mark for Japan
	Transit temperature
	Storage temperature
	Security key
	Patient Connector
	Telemetry

## 1.2 Description

The 24965 Patient Connector (patient connector), when paired with Medtronic apps on your mobile device, is used to interrogate and program implanted Medtronic devices. Interrogated information can be viewed or sent to the CareLink Network.

### 1.3 Intended use

The patient connector is a portable electronic device using low frequency inductive telemetry to communicate with Medtronic implanted heart devices. The patient connector uses Bluetooth technology to transmit implanted heart device data to a Medtronic Mobile app for further processing.

### 1.4 Contraindications

There are no known contraindications for the use of this device.

### 1.5 Warnings

These warnings apply in general to using the patient connector settings. For more information related to specific implantable device models, see the reference guides for the implantable device and the software.

**Battery exposure** – Exposing the patient connector to cold temperatures may result in a loss of performance and shortened patient connector service life.

**Damage due to impact** – Do not use the patient connector if it has sustained impact damage. Internal components may be damaged or exposed. Use of damaged equipment may impact user or patient safety.

**Diagnostic ultrasound** – Diagnostic ultrasound is an imaging technique that is used to visualize muscles and internal organs, their size, structures, and motion as well as any pathological lesions. It also is used for fetal monitoring and to detect and measure blood flow. Diagnostic ultrasound, such as echocardiogram, poses no risk of electromagnetic interference.

**Diathermy treatment (including therapeutic ultrasound)** – Diathermy is a treatment that involves the therapeutic heating of body tissues. Diathermy treatments include high frequency, short wave, microwave, and therapeutic ultrasound. Except for therapeutic ultrasound, do not use diathermy treatments on cardiac device patients. Diathermy treatments may result in serious injury or damage to an implanted device and lead system. Therapeutic ultrasound (including physiotherapy, high intensity therapeutic ultrasound, and high intensity focused ultrasound), is the use of ultrasound at higher energies than diagnostic ultrasound to bring heat or agitation into the body. Therapeutic ultrasound is acceptable if treatment is performed with a minimum separation distance of 15 cm (6 in) between the applicator and the implanted device and lead system, as long as the ultrasonic beam is pointing away from the device and lead system.

**Magnetic Resonance (MR) Unsafe** – The patient connector is MR Unsafe. Do not bring the patient connector into Zone 4 (magnet room), as defined by the American College of Radiology.

**Modification of equipment** – Do not modify this equipment. Modifications may reduce system effectiveness and impact user or patient safety. Modifying the device without the approval of Medtronic could void the user's authority to operate the equipment.

**Radiation therapy** – Exposing the device to therapeutic levels of ionizing radiation (such as that produced by cobalt machines or linear accelerators used for cancer treatment) may trigger inappropriate episode detection or corrupt the data stored in memory. It is advisable to check device function after radiation therapy. Cumulative radiation levels above 5 Gy may permanently damage the device.

**Unauthorized use** – The patient connector can be used with any compatible mobile device onto which the app is installed. Inappropriate programming could result if untrained persons obtain the patient connector and a REVEAL LINQ patient allows them to use it with the patient's device.

**Use of unapproved power supply** – Use only the Medtronic-supplied power supply with the patient connector. Use of an unapproved power supply may damage equipment or impact user or patient safety.

## 1.6 Precautions

**Attaching the tether kit** – Do not overtighten the screw when attaching the tether kit.

**Autoclaving** – Do not autoclave the patient connector.

**Damaged equipment** – If the case of the patient connector is cracked or if any of the connectors are damaged, contact your Medtronic representative. If there is damage to the power supply cord, replace the part and dispose of it according to local regulations or return the part to Medtronic.

**Do not immerse** – Take care to prevent liquid from entering the patient connector. Do not immerse the patient connector or any accessories in any liquid or clean them with aromatic or chlorinated hydrocarbons.

**Electrocautery/external defibrillation** – Do not position the patient connector over an implanted device during electrocautery or external defibrillation procedures.

**Maintenance and service** – Do not modify or do any maintenance or service on the patient connector while you are using it. Doing any of these tasks on the patient connector while it is in use can lower its effectiveness. Contact Medtronic at the number on the back cover of this manual if your patient connector is not working properly.

**Product and packaging labels and information** – If labels or information appear to be missing from the product or packaging, contact your local Medtronic representative at the address and telephone number located on the back cover of this document.

**Radio-frequency (RF) interference** – Portable and mobile RF communications equipment can interfere with the operation of the patient connector. Although this system has been approved, there is no guarantee that it will not receive interference or that any particular transmission from this system will be free from interference. To avoid interference, do not use the patient connector and mobile device within 2 m (6 feet) of a television, computer monitor or screen, or other wireless communications equipment such as wireless home network devices, mobile phones, cordless telephones and their base stations, or “walkie-talkies”. Using your patient connector near these devices could interfere with communication between your implanted heart device and the patient connector.

**Security** – Maintain adequate physical security of the patient connector to prevent unauthorized use that could lead to harm to patients. Bluetooth communication in the patient connector is encrypted for security. Inductive telemetry (A/B) uses short-range communication to protect patient information. If the patient connector should fail, there is no risk of patient harm.

**Use of wireless devices** – The patient connector incorporates radio-frequency (RF) communications components which may affect other devices and equipment in the medical environment. The use of wireless devices in the medical environment must be evaluated and authorized by the responsible organization. RF interference may affect device performance.

### 1.6.1 Environmental precautions

To ensure safe and effective operation, use the device with care to avoid damage to the patient connector from environmental factors that may impair its function. Care is exercised in design and manufacturing to minimize damage to devices under

normal use. However, electronic devices are susceptible to many environmental stresses including, but not limited to, the following examples.

- The unit is designed to be used indoors in a clinic or hospital.
- The unit should not be dropped or mishandled in such a manner as to cause physical damage to the unit. This may impair device function. Even if the unit works immediately after being dropped, operational damage may have occurred that may not be observed until some future time.
- Fluid should not be spilled on the unit. Even though care is exercised in design and manufacture of the unit to minimize leakage, fluid incursion may occur, which could impair functioning of the unit.
- The patient connector may be affected by electrostatic discharge (ESD). In an environment likely to cause ESD, such as a carpeted floor, discharge any charge collected on your body before touching the device.
- Do not open the device. The patient connector is constructed to minimize risk from environmental factors. Opening the unit may make the unit susceptible to environmental factors and may expose the patient or user to hazardous voltage or current.
- Rapid temperature changes may affect proper operation. Always allow the temperature to stabilize in the environment in which the device is used before using the device.
- Prolonged storage or operation of the device in high humidity may affect proper operation.

If there is any concern that damage has occurred, the unit should be returned to Medtronic for inspection and any needed repair.

Besides these listed examples, various other environmental factors may impair proper performance of the unit in the hospital setting. Always use good health management practices to prevent environmental damage to the unit.

## **1.7 Regulatory compliance**

### **1.7.1 US Federal Communications Commission (FCC)**

FCC ID: LF524965 (for patient connector). Contains FCC ID: T7V1316.

This device complies with part 15 of the FCC Rules. Operation is subject to the following two conditions: (1) This device may not cause harmful interference, and (2) this device must accept any interference received, including interference that may cause undesired operation.

## **1.8 Patient Connector functions**

The patient connector communicates with an implanted device. The patient connector also communicates with the Medtronic app running on a mobile device.

## **1.9 Security**

### **1.9.1 What hospitals and clinics can do to promote the security of patient connectors**

Maintain good physical controls over the patient connector. Having a secure physical environment prevents access to the internals of the patient connector.

Only connect the patient connector to managed, secure networks.

Update the software on the patient connector when Medtronic updates are available.

To increase security, store the patient connector and paired mobile device together in a secure location when not in use.



### 1.9.2 What to do if you suspect the patient connector has been compromised

Discontinue use of the patient connector if it does not behave as expected. Contact your Medtronic representative for further assistance.

### 1.10 Compatible components

The following compatible components are available for the patient connector:

- Power supply
- Tether kit
- Medtronic Model 6177 sterile sleeve

Contact your local Medtronic representative to order them.

**Warning:** Use the Medtronic-supplied components only. Use of unapproved components may reduce device effectiveness or impact user or patient safety.

## 2 Setup and configuration

### 2.1 System components

Figure 1. Patient Connector components

---

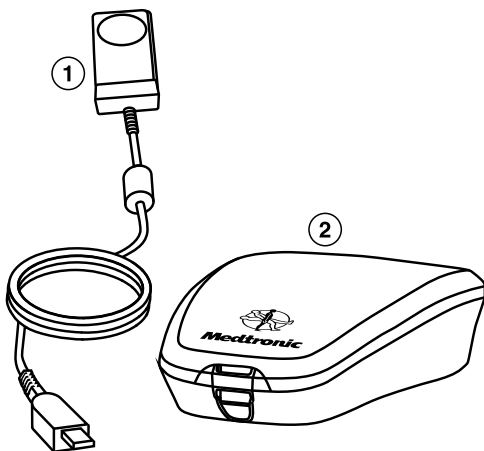

- 1 Power supply  
2 Patient Connector
-

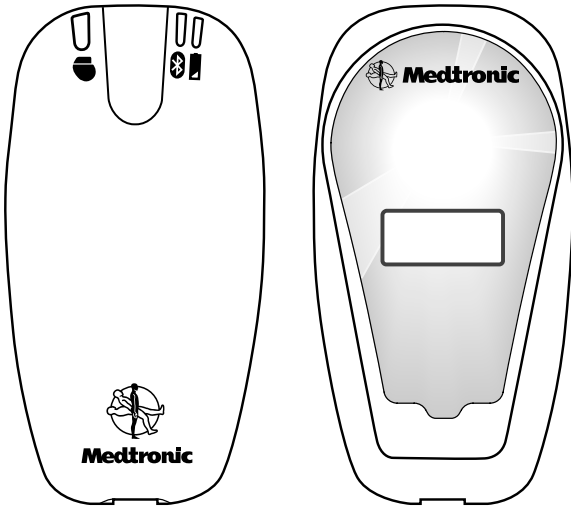

**Patient Connector** – Provides the communication link between the app and the patient's implanted device. The patient connector contains a radio-frequency (RF) transmitter and receiver. It must be held over the implanted device during a communication session.

**Mobile device (not supplied)** – When running the Medtronic app and paired with the patient connector, provides the user interface to communicate and program the implanted device, depending on the app installed.

**Power supply** – Connects to an AC power outlet to charge the patient connector battery.

**Tether kit** – Semi-permanently connects the patient connector to the power cord. Contains an Allen wrench, screw, and cable retainer.

**Warning:** Do not modify this equipment. Modifications may reduce system effectiveness and impact user or patient safety. Modifying the device without the approval of Medtronic could void the user's authority to operate the equipment.

## 2.1.1 Indicator lights

Figure 2.

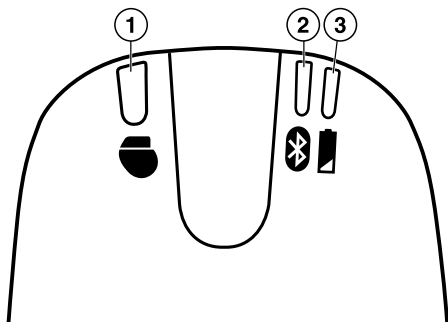



1 Telemetry Status

2 Bluetooth Connection Status

3 Battery Status

**Table 1.** Table with title and rules above and below header

Icon	Indicator	Color	Description
	Telemetry Status	Green	When lit, indicates that the patient connector is communicating with the implanted device.
	Bluetooth Connection Status	Blue	When flashing, indicates the patient connector is paired to the app and ready to use. When steadily lit, indicates the patient connector is in use.
	Battery Status	Amber	When lit, indicates the patient connector battery is low and should be charged.

## 2.2 Setup

This section describes how to:

- Charge the patient connector battery
- Download the app
- Pair the patient connector with the app
- Turn on the patient connector
- Attach the tether kit (optional)
- Troubleshoot potential interference

## 2.2.1 Charging the patient connector battery

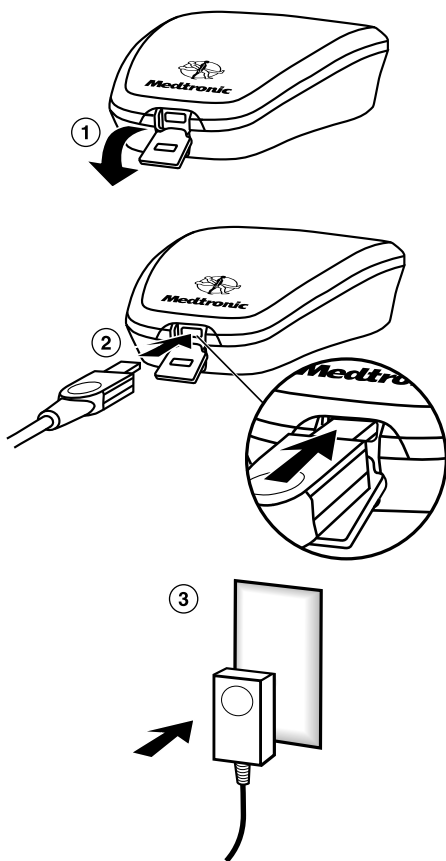

1. Open the power supply connector cover located on the bottom edge of the patient connector.
2. Connect power supply to the patient connector.
3. Plug the power cord into the AC power outlet (AC mains).

**Warning:** Use only the Medtronic-supplied power supply with the patient connector. Use of an unapproved power supply may damage equipment or impact user or patient safety.

## 2.2.2 Downloading the app

1. Make sure the mobile device is connected to the Internet.
2. Open the app store and search for the app.
3. Touch the app icon to download the app onto the mobile device.

4. Install the app.
5. Touch the app icon to open it.
6. Follow the instructions in the app to complete the installation.

### 2.2.3 Pairing the patient connector with the app

The patient connector uses a Bluetooth connection to communicate with the mobile device. You will need to pair each patient connector to the mobile device. You can have up to 20 patient connectors paired to one app.

1. Enable Bluetooth on the mobile device, if it is not enabled.
2. Open the app.
3. Touch CONTINUE in the app.
4. Locate the 8-digit security key code on the back of the patient connector.
5. Enter the security key code and touch CONTINUE.
6. Turn on the patient connector by pressing the button. The Bluetooth light on the patient connector will flash when it is communicating with the mobile device.
7. Accept the Bluetooth pairing request on the mobile device.
8. Complete the configuration steps in the app.

### 2.2.4 Turning on the patient connector

1. Locate the button on the top of the patient connector.
2. Press and release the button.
3. Complete the task.
4. The patient connector will turn off after 1 minute of inactivity. If the patient connector is not yet paired, it will turn off after 2 minutes. You can also hold the button down for 3 seconds to turn the patient connector off manually.

### 2.2.5 Attaching the tether kit

The tether kit provides a way to attach the patient connector to the power cord. This is an optional configuration.

1. Locate the plug over the power supply cover on the bottom of the patient connector.
2. Use the Medtronic-supplied Allen wrench to remove the screw.
3. Slide the cable retainer over the power supply plug of the power cord.
4. Attach the power supply plug side of the power cord to the patient connector.
5. Insert the screw into the bottom of the cable retainer and tighten the screw using the Allen wrench.

**Caution:** Do not overtighten the screw when attaching the tether kit.

**Warning:** Use the Medtronic-supplied components only. Use of unapproved components may reduce device effectiveness or impact user or patient safety.

### 2.2.6 Troubleshooting potential interference

To address possible harmful interference between the patient connector and other devices, which would result in reduced quality of service, you are encouraged to take one or more of the following measures to address the situation:

- Reorient or relocate the devices.
- Increase the separation between the patient connector and the devices.
- Connect the equipment to an outlet on a different circuit.
- Consult Medtronic for help.

## 3 Conducting a patient session

### 3.1 Position the patient connector

For an implantable device, the patient connector should be held directly against the patient's skin. The face of the patient connector must be parallel to and typically within 5 cm of the implantable device. Optimum position of the patient connector may not be directly centered over the implantable device. The distal end of the patient connector should be placed over the device with the device under the antenna. For best telemetry performance, do not use the patient connector close to sources of electrical noise.

### 3.2 Communicating with an implanted device

1. Touch the app icon to open it.
2. Follow the instructions in the app to start communicating with the device.
3. If the patient connector isn't already on, turn on the patient connector by pressing the button.
4. Hold the patient connector over the implanted device until the communication is complete. Communication can take up to 5 minutes.
5. Follow the instructions in the app to complete the task.

## 4 Maintaining the patient connector

### 4.1 Cleaning and disinfecting the 24965 Patient Connector

**Caution:** Do not immerse the patient connector in water or cleaning agents. Severe damage to the device may occur. Do not use automated machine washers. Do not sterilize the patient connector by ethylene oxide, gamma radiation, or steam-sterilization (autoclave). Damage may occur using these methods.

**Caution:** Turn the power off on the patient connector. Disconnect the power supply cord or unplug the power supply from the wall socket if the cable retention kit is used. Do not expose the patient connector to ethers, acetone, or chlorinated solvents. These solvents may damage the housings or labels.

#### Cleaning

##### 10% Bleach method

1. Before disinfection, clean the patient connector thoroughly using a 10% bleach and water solution and a dampened sterile gauze pad or sponge.
2. Wipe down to remove all visible soil.
3. Allow to air dry approximately 5 minutes or until dry.

#### Disinfecting

Use one of the methods below:

##### 70% Isopropyl method

1. Disinfect the patient connector by using a 70% isopropyl alcohol and a sterile prep pad, saturated gauze pad or sponge.
2. Wipe down all external surfaces and maintain a wet or damp exposure time of 15 minutes.
3. Allow to air dry approximately 5 minutes or until dry.

##### 10% Bleach method

1. Disinfect the patient connector by using a 10% bleach and water solution and a sterile saturated gauze pad or sponge.
2. Wipe down all external surfaces and maintain a wet or damp exposure time of 15 minutes.
3. Allow to air dry approximately 5 minutes or until dry.

## 4.2 Software updates

Software updates will be pushed automatically to the patient connector when you start a communication session. Updates can take up to 5 minutes. You must wait until the update is complete before you can continue with the session.

## 4.3 Specifications

**Table 2.** Patient Connector specifications

<b>Standards (The patient connector complies with the following:)</b>	
<b>Radio frequency wireless specifications and applicable standards</b>	
EMC	EN / IEC 60601-1-2 EN 300 328 EN 301 489 EN 302 195 EN 55022 Class B EN 55024 Class B
Radio	FCC CFR 47 RSS-210 R&TTE Directive 1999/5/EC
Patient safety	UL/CUL 60601-1, Type BF applied part EN 60601-1, Class 2, continuous operation, Type BF
<b>AC power requirement</b>	
Voltage	100–240 VAC nominal
Frequency	50/60 Hz nominal
<b>Battery</b>	
Type	Li-polymer, rechargeable
Capacity	1500 mAh
Charge duration	Standby: 15 days Operating: 2 hours (typical)
Voltage	3.7 V
<b>Power supply</b>	
AC/DC adapter in	100–240 VAC @ 50/60 Hz 100-240 VAC 0.5A 50-60 Hz
AC/DC adapter out	5 V @ 5.3 A 5 VDC 3 A
<b>Electrical safety requirements per IEC 60601-1:1988, Clause 19</b>	
Enclosure leakage current	≤ 0.1 mA
Patient leakage current A.C.	≤ 0.1 mA
Patient auxiliary current D.C.	≤ 0.01 mA
Patient auxiliary current A.C.	≤ 0.1 mA

**Table 2. Patient Connector specifications (continued)**

<b>Electrical safety requirements per IEC 60601-1:2005, Clause 8.7</b>	
Touch leakage current	≤0.1 mA
Patient leakage current A.C.	≤0.1 mA
Patient auxiliary current D.C.	≤ 0.01 mA
Patient auxiliary current A.C.	≤0.1 mA
<b>IEC 60529 Degrees of Protection Provided by Enclosures (IP Code) - AMD 7643: July 1993; AMD 10931: August 2000</b>	
Ingress	This product complies with international electrical safety rating IP22 with regard to ingress of dust, other foreign objects, and water as required by IEC 60601-1.
<b>Physical dimension and weight</b>	
Height	14 cm
Width	7.2 cm
Depth	3.2 cm
Weight	.18 kg
<b>Temperature limits</b>	
Operating	15 °C to 35 °C
Storage	- 20 °C to 60 °C
Transport	- 30 °C to 70 °C
<b>Humidity limits</b>	
Operating	75%
Storage	95% at 35 °C
Storage Transport	93% at 35 °C
<b>Altitude</b>	
Maximum	3000 m
<b>Connectivity and controls</b>	
<b>Bluetooth 2.1 and 4.0</b>	
Frequency range	2.4 GHz
Output power	Less than 10 mW EIRP
<b>Expected service life</b>	
5 years	

#### 4.3.1 Expected service life

The patient connector has an expected service life of 5 years. If you notice decreased operational time between battery charges or the battery no longer holds its charge, contact Medtronic to get a replacement patient connector.

#### 4.3.2 Disposal of the patient connector

Return the patient connector to Medtronic for proper disposal.







# Medtronic

**Medtronic, Inc.**

710 Medtronic Parkway  
Minneapolis, MN 55432  
USA

[www.medtronic.com](http://www.medtronic.com)  
+1 763 514 4000

**Medtronic USA, Inc.**

Toll-free in the USA (24-hour technical  
consultation for physicians and medical  
professionals)

Bradycardia: +1 800 505 4636

Tachycardia: +1 800 723 4636

**Europe/Middle East/Africa**

Medtronic International Trading Sàrl  
Route du Molliau 31  
Case Postale 84  
CH-1131 Tolochenaz  
Switzerland  
+41 21 802 7000

**Technical manuals**

[www.medtronic.com/manuals](http://www.medtronic.com/manuals)

© 2014 Medtronic, Inc.  
M999999A  
2014-11-20



\*M999999A\*