

# MEISIDA THUNDER EAGLE BRAND STUNT CAR SERIES

Mini Mouse Stunt Car

MSD0386



## Operation Manual

(Please read this manual carefully before operation)



For Age Group 6+

### Warnings:

- Improper use of battery may lead to dangers such as heat, breakage or leakage.
- Leakage from the battery may hurt skin, cleanse the skin contaminated.
- Do not drop the battery into water or fire or even dissolve the battery.
- Keep off fire, heat and wet places for operation, charge or storage.
- Switch off upon the end of play and take out the batteries of the transmitter.



### Cautions:

- The age under 6 are forbidden to play or dismantle the toy.
- Don't distort the antenna or the twist may injure people. Shouldn't the antenna distorted, Please be sure to change it due to it's dangerous.
- Don't play the car on roads to avoid the accident., Don't operate the car on soil or fine sand. Don't stop the wheels by force while it is in motion.

### Loading & Unloading of the battery for the transmitter(See Illustration)

1. Unscrew the battery cover by a screwdriver, open the battery cover, Install 3 1.5V "AA" batteries after checking the positive and negative poles, close the battery cover and tighten the screw.
2. Suggest use the brand high quality alkaline batteries.

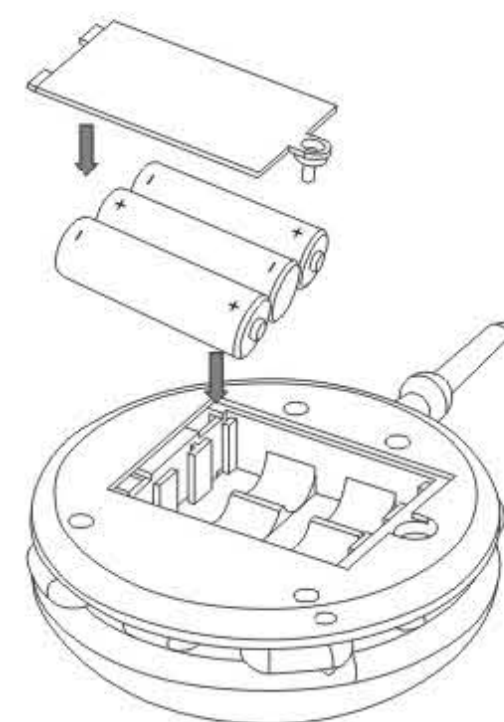

### Charging The Car

- 1, Push the battery cover of the transmitter open as per the directed arrow., pull out the charge plug.
- 2, Insert the charge plug into the charge jack on the car body for charge. The indicator light on the transmitter turns green during charge. After about 2 minutes, The green indicator light turns off after fully charged. Pull off the charge plug.

**Cautions:** Switch "OFF" the car during charge.

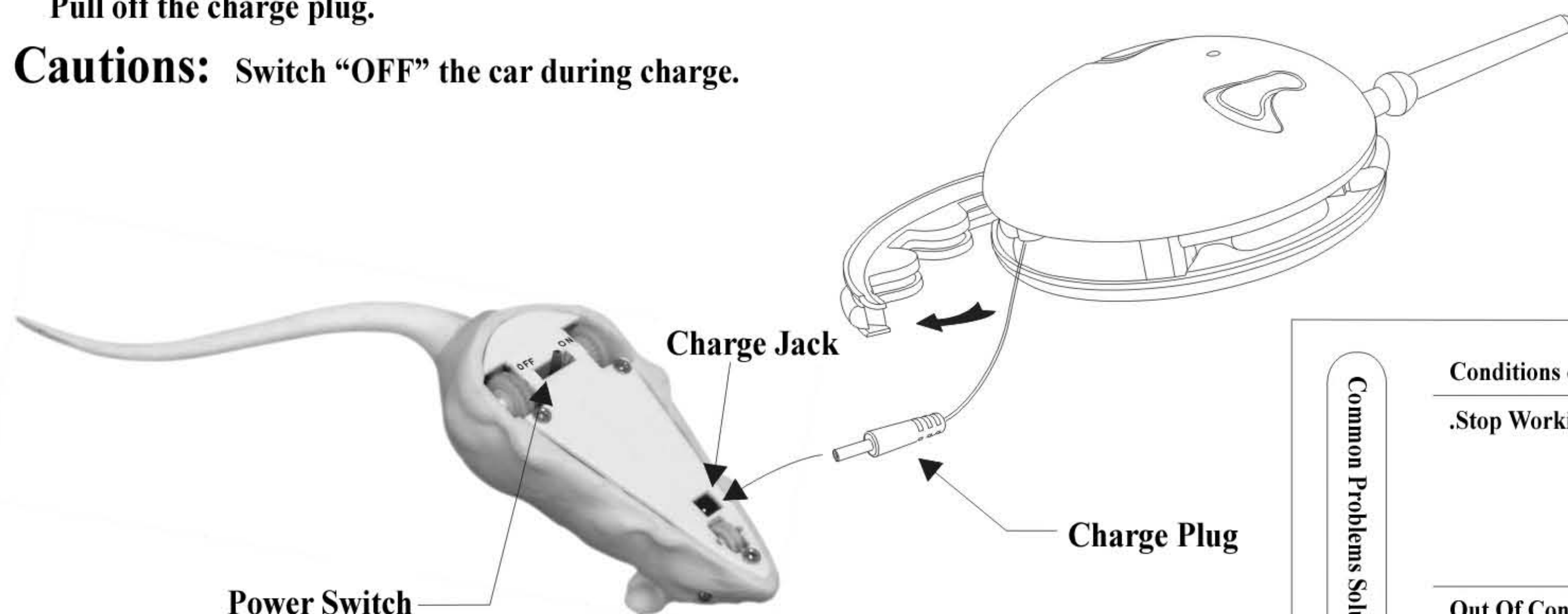

### The car actions illustrations for each button on the transmitter

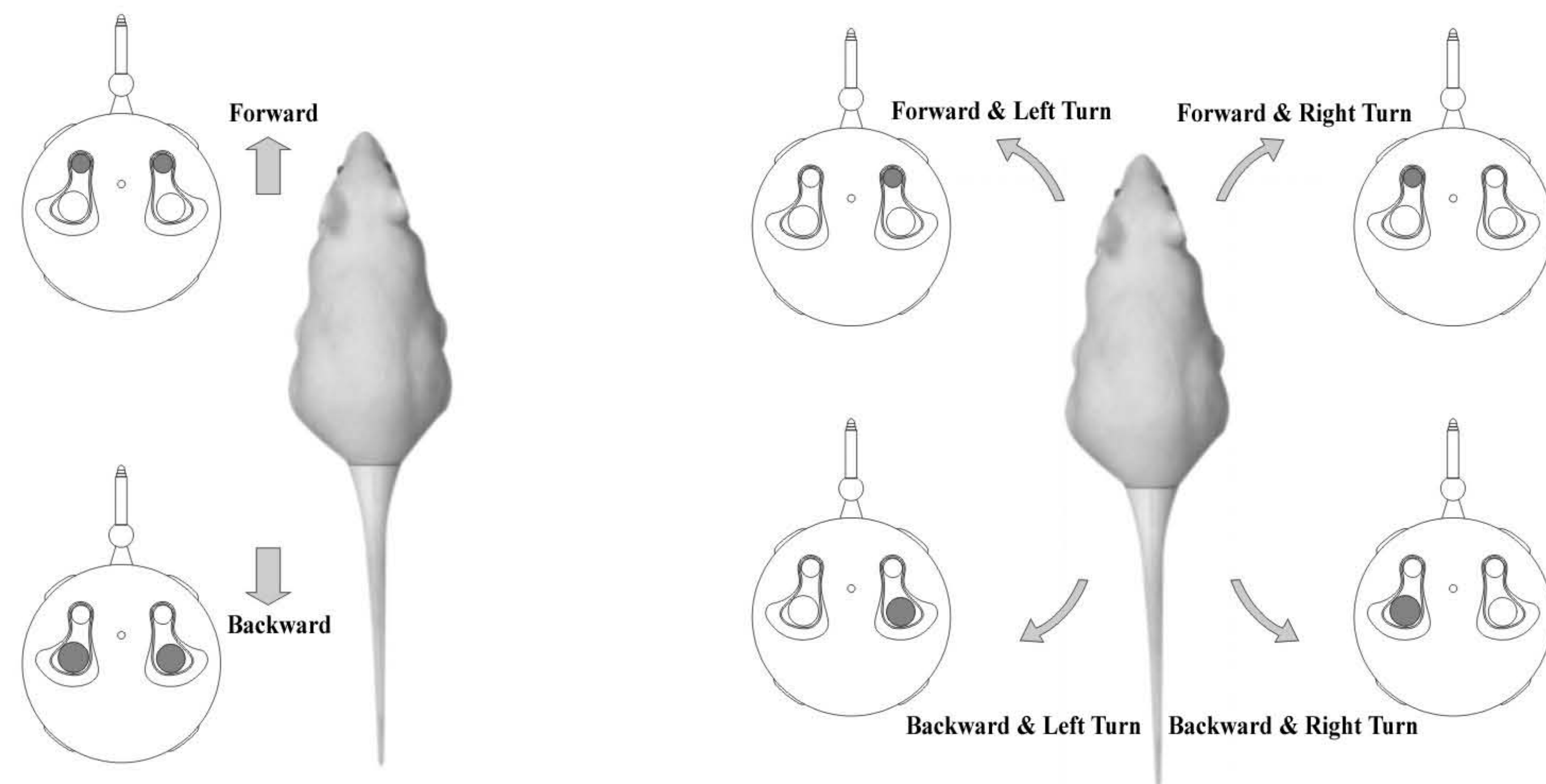

### Stunt actions buttons on the transmitter

Tail Rolling

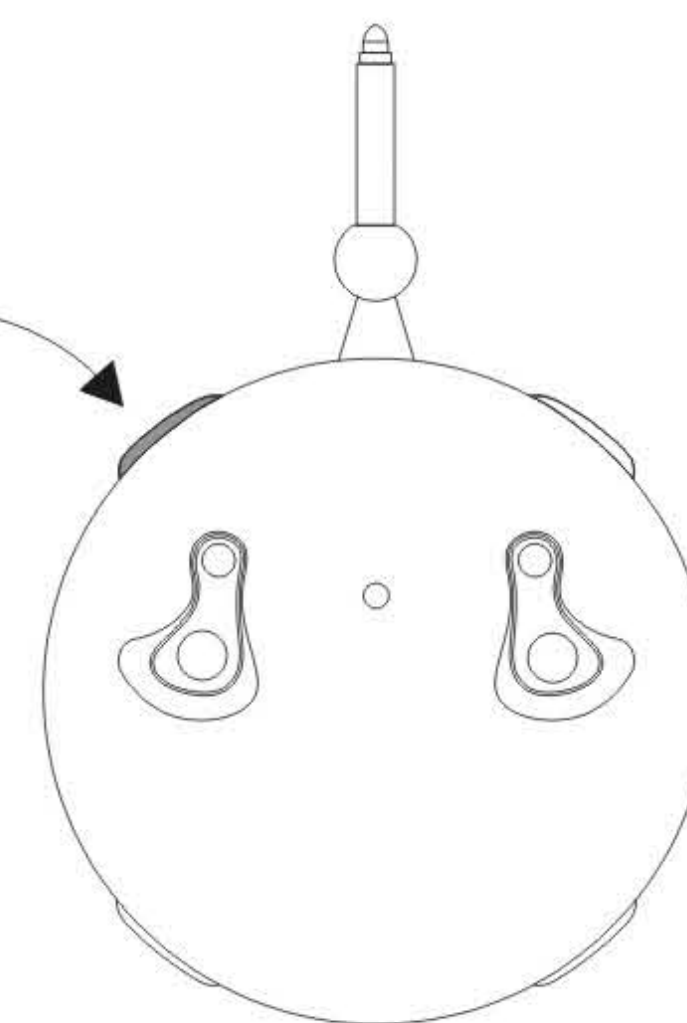

### Common Problems Solution

Conditions of the car	Reasons	Ways for inspection & adjustment
.Stop Working	No battery in the remote controller	Reloading the battery
	Incorrect installation of the battery of the remote controller	Reinstalling the battery
	Low battery of the remote controller	Change for new battery
	Low battery of the car	Recharging
Out Of Control	Low battery of the remote controller	Changing for new battery
	Radio Interference	Changing for new place
	Operation of radio control car at the same frequency nearby	Changing for new place

**Caution:** Any changes or modifications not expressly approved by the party responsible for compliance could void the user's authority to operate the equipment.  
**Note:** This equipment has been tested and found to comply with the limits for a Class B digital device, pursuant to part 15 of the FCC Rules. These limits are designed to provide reasonable protection against harmful interference in a residential installation. This equipment generates, uses and can radiate radio frequency energy and, if not installed and used in accordance with the instructions, may cause harmful interference to radio communications. However, there is no guarantee that interference will not occur in a particular installation. If this equipment does cause harmful interference to radio or television reception, which can be determined by turning the equipment off and on, the user is encouraged to try to correct the interference by one or more of the following measures:  
 --Reorient or relocate the receiving antenna.  
 --Increase the separation between the equipment and receiver.  
 --Connect the equipment into an outlet on a circuit different from that to which the receiver is connected.  
 --Consult the dealer or an experienced radio/TV technician for help.