



**ENGLISH**

**GV60 Bidirectional Control System for use with The Puck and Symax® Handsets together with myfire® App**

Installation and Operating Instructions

## GV60 Bidirectional Control System for use with The Puck and Symax® Handsets together with myfire® App

### Installation and Operating Instructions

#### APPLICATION AND COMPONENTS

Application .....	3
Components .....	3

#### GV60 – GAS COMBINATION CONTROL

Technical Data .....	4
Mounting Position .....	5
Gas Connections .....	5
Perform Pressure Test .....	6
Wiring .....	6
Thermocouple Circuit .....	6
Ignition Cable .....	6
Receiver .....	6
V Module .....	7
Knob Settings .....	7
Adjustment .....	7
Final Check .....	8
Manual Operation .....	9
Turn off Gas to Appliance .....	10
Automatic turn down to pilot .....	10
Automatic Shut off .....	10

TOUCHPAD/WALL SWITCH .....	11
SWITCH PANEL .....	11

#### SYMAX HANDSET

Technical Data .....	12
Synchronization Receiver/Symax Handset .....	12
General Notes .....	12

8-SYMBOL .....	13
Setting Fahrenheit or Celsius .....	13
Setting the Time .....	13
Child Proof .....	13
Manual Mode .....	14
Designated Low Fire and High Fire .....	14
Countdown Timer .....	14
Modes of Operation .....	15
Thermostatic Mode .....	15
Program Mode .....	15

Auxiliary Feature (2nd Burner Feature) .....	16
Eco Mode .....	16
myfire App .....	16

10-SYMBOL .....	17
Setting Fahrenheit or Celsius .....	17
Setting the Time .....	17
Child Proof .....	17
Manual Mode .....	18
Designated Low Fire and High Fire .....	18
Countdown Timer .....	18
Modes of Operation .....	19
Thermostatic Mode .....	19
Program Mode .....	19
Auxiliary Feature (2nd Burner Feature) .....	20
Eco Mode .....	20
Circulating Fan Operation .....	20
Light/Dimmer Operation .....	21
myfire App .....	21

#### THE PUCK HANDSET

Technical Data .....	22
Synchronization Receiver/The Puck Handset .....	22
Modes of Operation .....	22

#### MYFIRE WI-FI BOX (B6R-W2...)

Technical Data .....	23
Modes of Operation .....	23

#### MYFIRE APP SETUP

App setup .....	24
-----------------	----

#### WIRING DIAGRAMS

Basic .....	25
Fan, Light/Dimmer, Latching Solenoid .....	26
2 <sup>nd</sup> Thermocouple .....	27
Receiver for Power Flue Control .....	28
Myfire app setup .....	29

## IMPORTANT SAFETY INFORMATION

### ⚠ WARNING

Read these instructions carefully and completely before installing or operating. Failure to follow them could result in a fire or explosion causing property damage, personal injury, or loss of life. Service and installation must be performed by a trained/experienced service technician.

#### WHAT TO DO IF YOU SMELL GAS

- Do NOT operate any appliance.
- Do NOT touch any electrical switch; do NOT use any phone in your building.
- Immediately evacuate the area and contact the gas supplier. Follow the gas supplier's instructions.
- If you cannot reach the gas supplier, call the fire department.

Installation and service must be performed by a qualified installer, service agency, or the gas supplier. Installation shall conform with local codes, or in the absence of local codes, in accordance with the National Fuel Gas Code ANSI Z223.1/NFPA 54 or the IFGC or CSA B149.1. All piping and tubing must comply with local codes and ordinances.

Use only your hand to push in or turn the gas control knobs. Never use tools. If a knob will not push in or turn by hand, do not try to repair it. Call a qualified service technician. Force or attempted repair can result in a fire or explosion.

Do NOT use a product if you suspect it has been subjected to high temperatures, damaged, tampered with, or taken apart. Do NOT use a product if you suspect it has been under water or that liquid has seeped into the product. Any of these incidents can cause leakage or other damage that may affect proper operation and cause potentially dangerous combustion problems.

Damper position must be in accordance with Manufacturer's Installation Instructions and all applicable standards. Failure to follow them could result in a fire or explosion causing property damage, personal injury, or loss of life.

Do NOT store or use gasoline or other flammable vapors and liquids in the vicinity of this control or other appliances.

### ⚠ WARNING

#### ELECTRIC SHOCK HAZARD

- Read these instructions carefully. Failure to follow them could result in property damage, personal injury, or loss of life.
- This control must be electrically wired and operated in accordance with all codes and local regulations. Service and installation must be performed by a trained, experienced service technician.
- Do NOT use the control if you suspect it may be damaged.

## GENERAL INSTALLATION INFORMATION

### NOTICE

It is the responsibility of the OEM to consider the following:

- The location of the GV60 system components will significantly effect the radio signal strength.
- The type of materials (e.g. sheet metal) used in the construction of the gas fireplace will significantly effect the radio signal strength.
- Operate the system with a dedicated mains power supply and/or batteries.
- Do not use near household electrical wiring and/or magnetic fields.
- Other transmitters using the same signal will negatively affect the radio signal strength.
- Adjustment of the on-board antenna on the receiver can improve signal strength.
- Do not store or locate the GV60 system components in a hot, cold, or humid environment.

# APPLICATION AND COMPONENTS

## APPLICATION

GV60 is a battery-powered electronic remote ignition and control system for gas appliances with pilot burners and ODS systems.

## COMPONENTS

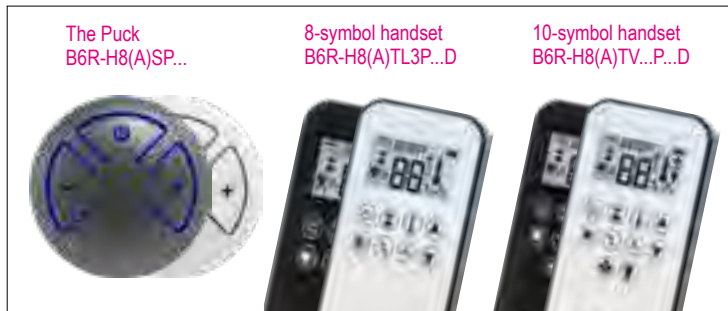

Figure 1: Handsets



Figure 2: Operation



Figure 3: Basic



Figure 4: Additional Function (Latching Solenoid, Fan, Light/Dimmer)



Figure 5: Mains Adapter

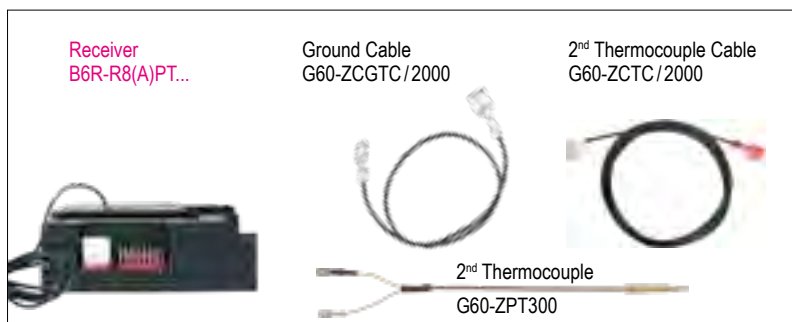

Figure 6: 2nd Thermocouple Option



Figure 7: myfire app setup

ENGLISH

© 2019 Meritk Maxitrol GmbH & Co. KG. All Rights Reserved.

## GV60 – GAS COMBINATION CONTROL

The GV60 remote electronic ignition and control system operates in conjunction with standard pilot burner and ODS systems. When used with thermostatic remote, the GV60 fully modulates between low fire and high fire. Current applications include fireplaces and log sets.

### TECHNICAL DATA

#### APPROVALS

- CSA: Multifunctional gas control according to ANSI Z21.78 6.20 and ANSI Z21.20 6.20 for U.S. & Canada  
 CE: Gas Appliances Regulation 2016/426/EU and DIN EN 298, DIN EN 126, DIN EN 13611, 2014/53/EU (RED)

#### FUELS

- CSA: Suitable for natural, manufactured, mixed gases, liquefied petroleum gases, and LP gas-air mixtures.  
 CE: Suitable for use with gases of EN 437 gas family 1, 2 and 3.

#### PRESSURE DROP/CAPACITY

- CSA: @ 1" w.c. at 65,000 BTU/hr for 0.65 s.g. natural gas  
 CE: 2.5 mbar (0.25 kPa) at 1.2 m<sup>3</sup>/h air

#### RANGE OF REGULATION

- CSA: 10,000 to 85,000 BTU/hr  
 CE: Class C according EN 88

#### REGULATOR ADJUSTMENT

- CSA: 3" w.c. to 5" w.c.; 8" w.c. to 12" w.c.  
 Convertible Regulator: 3 to 4.5" NG/8.5 to 11.5" LP  
 CE + CSA: 3" w.c. to 12" w.c. (7.5 to 30 mbar)  
 CE: 5 to 40 mbar (0.5 to 4 kPa)

#### MAXIMUM INLET PRESSURE

- CSA: ½ psi (14" w.c.)  
 CE: 50 mbar (5 kPa)

#### MAIN GAS CONNECTION

- CSA: ¾ NPT (ANSI/ASME B1.20.1)  
 CE: Rp ¾ (ISO 7-1/EN 10226-1), compression fittings for 8 mm, 10 mm or 12 mm tube

#### PILOT GAS CONNECTION

- CSA: 7/16-24 UNS for ¼" or ⅜" tubing  
 CE: M10x1 for 4 mm or 6 mm tubing

#### INLET AND OUTLET CONNECTION

Side or Bottom

#### MAXIMUM ALLOWED TORQUE

- INLET, OUTLET, LATCHING SOLENOID ¾"
- CSA: 280 inch-pounds
- CE: 35 Nm
- LATCHING SOLENOID 8 mm tube
- CE: 20 Nm
- PILOT GAS CONNECTION
- CSA: 100 inch-pounds
- CE: 15 Nm

#### THERMOCOUPLE / INTERRUPTER BLOCK

11/32-32 UNS, M10x1, M9x1, M8x1

#### AMBIENT TEMPERATURE RANGE

- CSA: Combination Control: 32 °F to 176 °F  
 Latching Solenoid Valve: 32 °F to 176 °F  
 Misc. cables: 221 °F  
 Relay with Cable: 158 °F  
 CE: Combination Control: 0 °C to 80 °C  
 Latching Solenoid Valve: 0 °C to 80 °C  
 Misc. cables: 105 °C  
 Relay with Cable: 70 °C

#### GENERAL RADIO FREQUENCY INFORMATION

Amendment: This device complies with Part 15 of the FCC Rules. **It also contains licence-exempt transmitter(s)/receiver(s) that comply with Innovation, Science and Economic Development Canada's licence-exempt RSS(s). Operation is subject to the following two conditions:**

- (1) This device may not cause interference.
- (2) This device must accept any interference, including interference that may cause undesired operation of the device.

Changes or modifications not expressly approved by the party responsible for compliance could void the user's authority to operate the equipment. To satisfy ISED exposure requirements a separation distance of 20 cm or more should be maintained between the antenna of this device and persons during operation. To ensure compliance, operations at closer distances than this are not recommended.

**NOTE:** This equipment has been tested and found to comply with the limits for a Class B digital device, pursuant to part 15 of the FCC Rules. These limits are designed to provide reasonable protection against harmful interference in a residential installation. This equipment generates, uses and can radiate radio frequency energy and, if not installed and used in accordance with the instructions, may cause harmful interference to radio communications. However, there is no guarantee that interference will not occur in a particular installation. If this equipment does cause harmful interference to radio or television reception, which can be determined by turning the equipment off and on, the user is encouraged to try to correct the interference by one or more of the following measures:

- Reorient or relocate the receiving antenna.
- Increase the separation between the equipment and receiver.
- Connect the equipment into an outlet on a circuit different from that to which the receiver is connected.
- Consult the dealer or an experienced radio/TV technician for help.

Compliant with the EU-Radio Equipment Directive 2014/53/EU (RED).

#### ▲ WARNING

It is the appliance manufacturer's responsibility to determine GV60's suitability for a specific application.

#### ▲ WARNING

Do NOT remove screws from the gas valve. Do NOT adjust and/or alter any components marked with tamper indicating paint. Motor knob is not to be removed.

**▲ WARNING**

1. Turn off gas supply at the appliance service valve before starting installation, and perform a Gas Leak Test after the installation is complete.
2. Install the sediment trap or filter (where required) in the gas supply line to prevent contamination of the gas valve (see figure 8, page 5).
3. Use only your hand to push in or turn the gas control knobs. Never use tools. If a knob will not push in or turn by hand, do not try to repair it. Call a qualified service technician. Force or attempted repair will void warranty and can result in a fire or explosion.

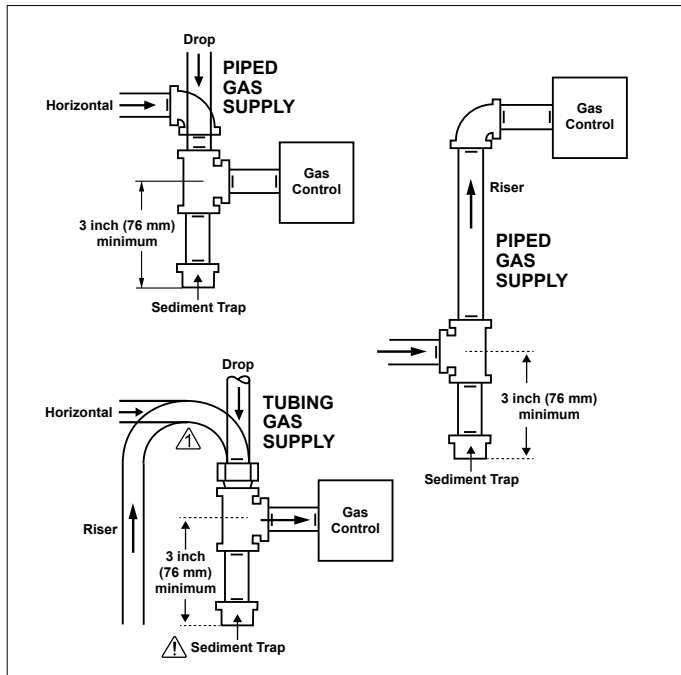

Figure 8: Sediment Trap (where required)

**MOUNTING POSITION**

In upright position, gas control knobs are on top of the valve. Valve may be mounted 0° to 90° any direction (including vertical) from the upright position. Valve must NOT be mounted upside down.

**LOCATION**

Locate the combination gas valve where it is not exposed to steam cleaning, high humidity, dripping water, corrosive chemicals, dust or grease accumulation, or excessive heat.

To assure proper operation, follow these guidelines:

- Locate combination gas valve in a well-ventilated area.
- Mount combination gas valve high enough to avoid exposure to flooding or splashing water.
- Make sure the ambient temperature does not exceed the ambient temperature ratings for each component.

**▲ WARNING**

GV60 standard version is suitable for indoor use only.

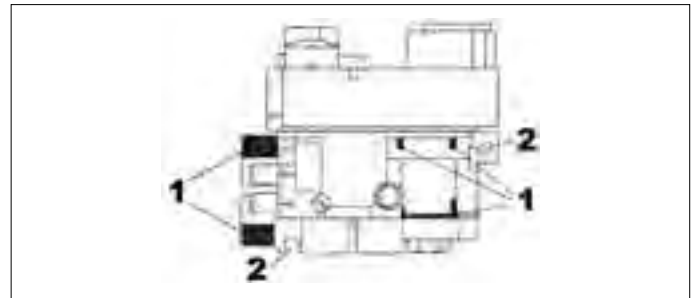

Figure 9: 1 = Clamp Areas, 2 = Mounting Points

**GAS CONNECTIONS**

**▲ WARNING**

**Fire or Explosion Hazard. Can cause property damage, severe injury, or death.** Do NOT bend tubing at gas valve connection point after compression fitting has been tightened. This can result in a gas leak at the connection.

**▲ WARNING**

Use new, properly reamed pipe free from metal or material chips. When tubing is used, assure that ends are square, deburred and clean. All tubing bends must be smooth and free of distortion.

When threads are tightened, the valve must be held at the designated clamping points (see figure 9, page 5).

**▲ WARNING**

Do not overtighten connections. Overtightening can damage the control body resulting in a leak or a control malfunction. (see MAXIMUM ALLOWED TORQUE, see page 4)

**Main Gas (Tubing Connections)**

1. Do not use pipe joint compound. Mertik Maxitrol does NOT recommend the use of Teflon®/PTFE tape.
2. Slip nut and ferrule over tubing.
3. Slide nut and ferrule into place, and insert tubing into inlet/outlet connection until it bottoms. Turn finger tight.
4. Use a wrench to tighten nut about 1 turn beyond finger tight.

**Main Gas (Pipe Connections)**

1. Mertik Maxitrol does NOT recommend the use of Teflon®/PTFE tape.
2. Pipe to be inserted into the valve must be the proper thread length and to gauge. Thread that is cut too long can cause distortion or malfunction if inserted too deeply. Thread cut too short can cause thread stripping if over-torqued.
3. Apply a moderate amount of approved pipe sealant to the pipe only, leaving the two end threads bare.
4. Connect pipe to valve inlet and outlet.

**Pilot Gas (Tubing Connections)**

1. Do not use pipe joint compound. Mertik Maxitrol does NOT recommend the use of Teflon®/PTFE tape.
2. Slip fitting over tubing.
3. Insert pilot tubing into pilot outlet until it bottoms. Turn fitting finger tight.
4. Turn with a wrench until you shear off the ferrule. Turn an additional 3/4 turn to make a gas tight seal.
5. Connect other end of tubing to pilot burner.

**▲ WARNING**

The control valve must be in the closed position when the gas supply line is tested for leakage up to 150 mbar (15 kPa; 2 PSI). Above 150 mbar (15 kPa; 2 PSI) the control valve must be isolated from the gas supply.

**PERFORM PRESSURE TEST**

1. Check carefully for gas leaks immediately after the valve has been installed and the gas turned on. **Do this before attempting to operate the appliance or other gas burning device.**
2. Using a clean brush, apply an approved leak test solution to the tubing and pipe connections. Bubbles indicate a leak.
3. If no leakage is detected, light the main burner.
4. With the main burner in operation, apply an approved leak test solution to all tubing and pipe connections (including adapters) and the valve inlet and outlet. Bubbles indicate a leak.
5. If a leak is detected, tighten pipe connections (including adapters) according to "Gas Connections" (see page 5).

**▲ WARNING**

Do NOT use if leakage is detected. There is a danger of fire or explosion depending on conditions.

**WIRING**

(see figures 26-30, pages 25-29)

Connect all components according to the appropriate wiring diagram.

- When GV60 components are installed, make sure they are not exposed to dirt, oil, grease or other chemical agents.
- Do not permit foreign particles under plastic cover.
- Place ON/OFF switch (if equipped) where it is easily accessible for the user.

**NOTICE**

Wiring of valve and receiver must be completed before starting ignition. Failure to do so could damage the electronics.

**THERMOCOUPLE CIRCUIT**

Total resistance of thermocouple circuit should be minimized to ensure proper operation.



Figure 10



Figure 11



Figure 12

**NOTICE**

The use of the Mertik Maxitrol interrupter block is recommended. Keep connection of interrupter block and thermocouple clean and dry. Avoid excessive bending of the thermocouple tubing during installation (min. 1" radius; 2.5 cm) as this can cause it to fail.

1. Tighten brass interrupter block into valve ¼ turn beyond finger tight. If necessary, an additional ¼ turn is possible.

**CAUTION:** Further tightening will damage the plastic sleeve in the brass interrupter block and will cause a short in the circuit.  
**NOTE:** Do not over-torque or under-torque the interrupter block to achieve a specific slot alignment.

2. Slide spade connectors into plastic insert (see figure 10, page 6).
3. Slide plastic insert with spade connectors into the brass interrupter block until it snaps (see figure 11, page 6).
4. While holding the interrupter block with a wrench, thread the thermocouple into the female end of the interrupter block ¼ – ½ turn beyond finger tight (see figure 12, page 6).

**IGNITION CABLE**

**AMBIENT TEMPERATURE RANGE**

CSA: Ignition Cable: 302 °F  
 CE: Ignition Cable: 150 °C

**CAUTION:** Damage and/or interference will occur to the GV electronic system if the ignition cable (high voltage) is not separated from other GV system wiring.

**NOTICE**

Do not damage the ignition cable while attaching it to the ignition electrode. When the cable is in place, avoid contact with sharp objects or edges.  
 With cables longer than 900 mm, avoid contact with metal parts, as this could decrease spark.

**RECEIVER**

**AMBIENT TEMPERATURE RANGE**

CSA: Receiver without internal batteries: 32 °F to 176 °F  
 Receiver with internal batteries: 32 °F to 131 °F  
 CE: Receiver without internal batteries: 0 °C to 80 °C  
 Receiver with internal batteries: 0 °C to 55 °C

**RADIO FREQUENCY**

CSA: 918.0 MHz for U.S. (FCC), Canada (ISED), New Zealand (RNZ) and Australia (ACMA) (handset, receiver)  
 CE: 868.1 MHz for Europe (handset, receiver)  
 (see general radio frequency information on page 4.)

**POWER CONSUMPTION (STANDBY)**

CSA + CE: B6R-R8(A)... : 0.7 mW

**POWER CONSUMPTION (NOMINAL)**

CSA + CE: B6R-R8(A)... : 0.8 mW

**POWER CONSUMPTION (MOTOR TURN)**

CSA + CE: B6R-R8(A)... : 0.25 W

**POWER CONSUMPTION (IGNITION)**

CSA + CE: B6R-R8(A)... : 3.0 W

**POWER SUPPLY**

Receiver: 4 x 1.5 V "AA" (quality alkaline recommended)  
 An AC mains adapter may be used instead of batteries.

**NOTICE**

Only the Mertik Maxitrol AC mains adapter (see figure 5, page 3) or one preapproved by Mertik Maxitrol can be used. Use of other adapters can render the system inoperable.

**NOTICE**

The antenna (see page 25) must not cross or come into contact with the ignition wire. This will render the receiver inoperable.

**Batteries – Receiver**

**NOTICE**

Wiring of valve and receiver must be completed before starting ignition. Failure to do so could damage the electronics.

**NOTICE**

The handsets and receivers are not interchangeable with previous electronics.

**▲ WARNING**

To avoid damaging the electronics, do NOT use metal tools to remove the batteries from the handset/receiver.

**▲ WARNING**

- Without using a mains adapter, battery replacement is recommended at the beginning of each heating season.
- Old or dead batteries should be removed immediately. If left in the unit the batteries can overheat, leak, and/or explode.
- Do NOT expose batteries (including during storage) to direct sunlight, excessive heat, fire, moisture, or severe impact. Each of these conditions can cause the batteries to overheat, leak, and/or explode.
- Batteries must be kept within their recommended temperature limits (ambient battery temperature range: 32 °F to 131 °F / 0 °C to 55 °C).
- New and old batteries and different brands of batteries should not be used together. Mixing of various batteries can cause the batteries to overheat, leak, and/or explode.

- Low battery indication: frequent beeps for 3 seconds when motor turns.
- The V module for fan speed control and light/dimmer provides the receiver with power. The batteries in the receiver can be used for automatic backup in case of power outage.

**NOTICE**

To keep the receiver free from debris, dirt, and humidity, do not remove the receiver from the plastic bag until all construction is complete.

**Radio Frequency Receiver and Handset**

A code is selected automatically for all Mertik Maxitrol electronics from among 65,000 codes available. The receiver must be paired with the handset.

**Synchronization Receiver/Symax Handset**

(First time use only)

1. Insert batteries or connect AC mains power. The module for circulating fan and light/dimmer includes a mains adapter. With mains adapter, batteries can be used for backup.
2. Place ON/OFF switch (if equipped) to **ON** position.
3. The receiver has to learn the handset code:  
Press and hold the receiver's reset button (see figure 26, page 25) until you hear two (2) beeps. After the second, longer beep, release the reset button. Within the subsequent 20 seconds press the **▼** button on the handset. **"CONN" and a running number from 1 to 8 are displayed** on the handset confirming

the synchronization and data exchange is in process (see figure 13, page 7). **Two (2) short beeps confirm the code is set.** After successful synchronization the current state of the gas fire is displayed on the handset.

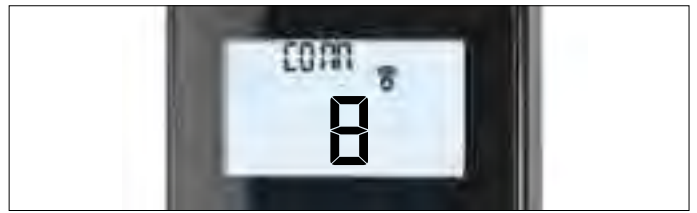

Figure 13: Synchronization of Symax handset in process

**NOTE:** This is a one time setting only, and it is not required after changing the batteries in the handset or receiver.

**NOTE:** Both the receiver and the handset transmit and receive signals (bidirectional). Handset and receiver sync status information every 10 s during first 2 min – afterward every 4 to 6 min. Touching a handset button causes an immediate synchronization.

**NOTE:** When the RF receiver is placed in the appliance, the surrounding metal can reduce reception considerably.

**NOTICE**

The handsets and receivers are not interchangeable with previous electronics.

**Synchronization Receiver/The Puck Handset**

(First time use only)

1. Insert batteries or connect AC mains power. The module for circulating fan and light/dimmer includes a mains adapter. With mains adapter, batteries can be used for backup.
2. Place ON/OFF switch (if equipped) to **ON** position.
3. The receiver has to learn the Puck code:  
Press and hold the receiver's reset button (see figure 26, page 25) until you hear two (2) beeps. After the second, longer beep, release the reset button. Within the subsequent 20 seconds press and hold the **"-"** button on the Puck (approx. 4 seconds) until two (2) beeps confirm the set of the code.

**NOTE:** This is a one time setting only, and it is not required after changing the batteries in the handset or receiver.

**NOTE:** The receiver transmits and receives signals (bidirectional) and the handset transmits signals (unidirectional). Handset and receiver sync status information every 4 to 6 min.

**NOTE:** When the RF receiver is placed in the appliance, the surrounding metal can reduce reception considerably.

**NOTICE**

The handsets and receivers are not interchangeable with previous electronics.



**V MODULE**

**POWER SUPPLY**

CSA: Inlet: 115 VAC/60 Hz; 210 VA  
 Outlet: 115 VAC/60 Hz; 100 VA each  
 Built-in fuse: 2.5A  
 CE: Inlet: 230 VAC/50 Hz; 210 VA  
 Outlet: 230 VAC/50 Hz; 100 VA each  
 Built-in fuse: 2.5A

**AMBIENT TEMPERATURE RANGE**

CSA: V Module: 176 °F  
 CE: V Module: 80 °C

**POWER CONSUMPTION (STANDBY)**

CSA + CE: G6R-B...V2: 0.5 W  
 G6R-B...V3: 0.3 W

**POWER CONSUMPTION (NOMINAL)**

CSA + CE: Depends on connected devices (fan, light)

Follow wiring diagram (see figure 27, page 26). Connect the Fan and Light first and then connect the power supply. An LED indicates the power is ON. Use Molex connectors or connect wires to screw terminals.

**KNOB SETTINGS**

Knobs function as follows (see figure 14, page 8):

KNOB	POSITION	FUNCTION
Main valve knob	OFF	Prevents main gas flow through valve.
Main valve knob	ON	Permits main gas flow through valve if the pilot is lit and thermocouple is generating sufficient power.
Manual knob	MAN	Allows the pilot to be manually ignited and prevents main gas flow.
Manual knob	ON	Allows for automatic ignition.

**ADJUSTMENT**

**⚠ WARNING**

It is the appliance manufacturer's responsibility to determine GV60's suitability for a specific application.

**⚠ WARNING**

Do not attempt to remove screws from the top of gas valve. Do not change any adjustments marked with tamper indicating paint. Motor knob is not to be removed.

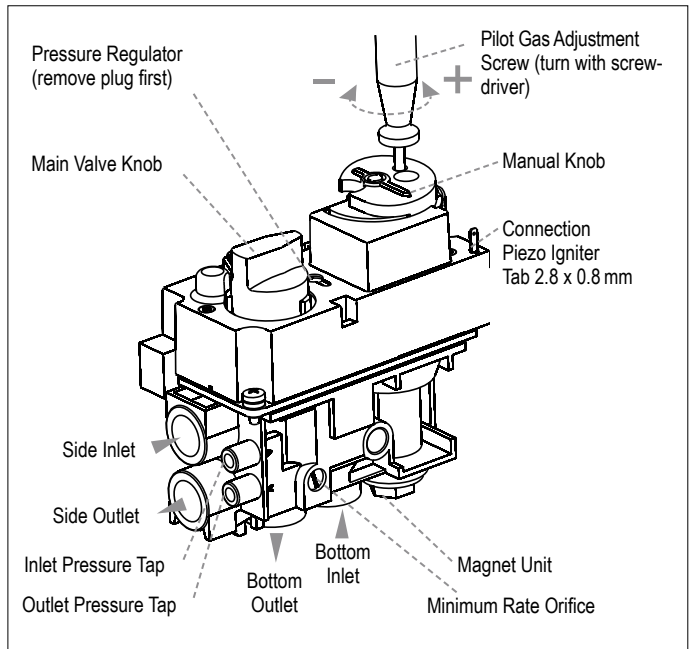

Figure 14: GV60, Connections and Adjustment Options

**Pilot Flame Adjustment**

(Vented Units Only)

The pilot flow adjustment is preset to maximum at the factory. The pilot flame should envelope 3/8" to 1/2" of the thermocouple (see figure 15, page 8).

1. The adjustment screw can be reached through a hole in the MANUAL knob (see figure 14, page 8).
2. Turn the MANUAL knob to the **ON** position.
3. It is now possible to pierce through a film on the cover with a screwdriver to reach the adjustment screw beneath.
4. Turn the adjustment screw clockwise ↻ to decrease or counterclockwise ↻ to increase pilot flame.

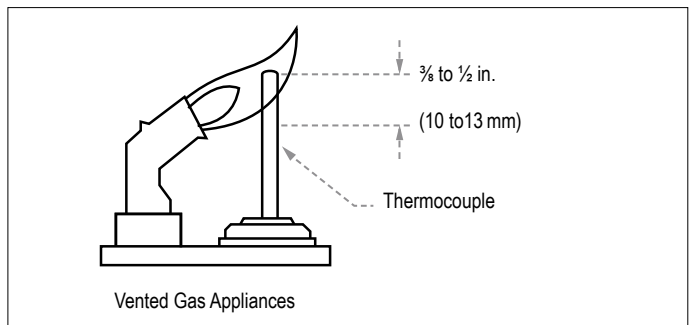

Figure 15: Proper Flame Impingement on Thermocouple

**Outlet Pressure Adjustment**

(Vented Units Only)

**STANDARD REGULATOR OR THROTTLE**

(Throttle CE Only)

1. Connect a pressure manometer to the valve outlet pressure tap. Pressure tap is opened by turning the screw counterclockwise ↻. Pressure regulator or throttle are located under the cover and can be reached by removing the plug (see figures 14, page 8 and 16, page 8).
2. Turn MANUAL knob and main valve knob to the **ON** position.
3. Turn pressure regulator adjustment screw to set required burner pressure (high fire). Pressure is increased by turning clockwise ↻ (pressure regulator models), or decreased by turning counterclockwise ↻.

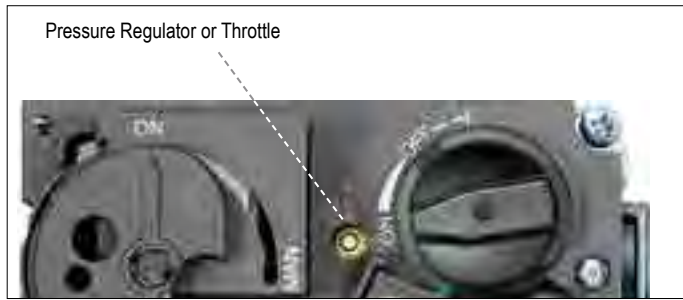

Figure 16: Combination Control GV60, Cover

**NOTE:** Throttle model's pressure is increased by turning counterclockwise ↺; or decreased by turning clockwise ↻.

4. After adjustment, replace the plug.
5. If no other adjustments are required, close pressure tap(s) by turning the screw(s) full clockwise ↻. Check all connections/pressure tap(s) for leaks.
6. If the desired outlet pressure or flow cannot be achieved by adjusting the gas valve, check the gas valve inlet pressure using a manometer at the valve inlet pressure tap. If the inlet pressure is in the normal range, replace the gas valve; otherwise, take necessary steps to assure proper gas pressure to the valve.

**CONVERTIBLE PRESSURE REGULATOR**  
(CSA Only; Optional)

Convertible regulators are designed to deliver either of two fixed outlet pressures for Natural Gas (NG) or LP Gas. To change from one gas to the other, turn the conversion plug (see figure 17, page 9) counter clockwise to remove. Unsnap and remove the plastic part, rotate it 180°, and then slide it back on the conversion plug until it snaps. Turn the conversion plug clockwise until it bottoms out.

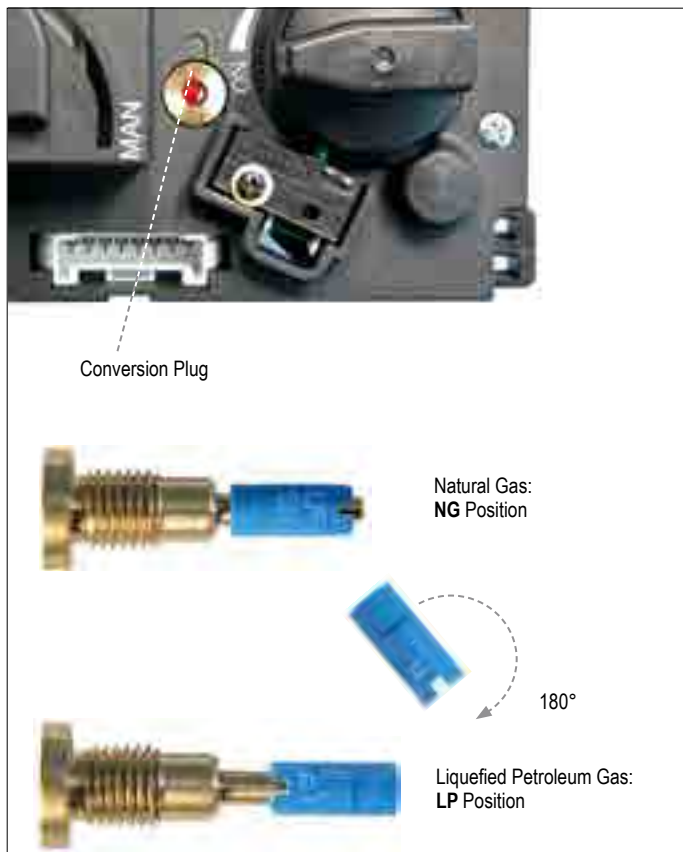

Figure 17: Conversion from one gas to another

**Minimum Gas Flow Adjustment**  
(Vented Units Only)

1. Set the control into low fire setting by turning the motor knob to **OFF** position and back until the valve opens.
2. The minimum rate can be set either by screwing in a calibrated minimum rate screw (fixed orifice) or an adjustable minimum rate screw. Controls with adjustable screws without a customer specific setting are factory set at maximum flow.
3. Turn the screw clockwise ↻ to decrease the minimum flow.
4. Care should be taken to screw the fixed orifice until it stops.
5. Close pressure tap(s) by turning the screw(s) full clockwise ↻. Check all connections/pressure tap(s) for leaks.

**Changing the Fuel Type**  
(Vented Units Only; see "Convertible Pressure Regulator")

GV60 can be converted to meet the manufacturer's requirements for a specific gas type. Adjustments of pressure regulator, minimum rate and pilot gas are according to above-mentioned instructions. To convert for LPG CE it is necessary to block the pressure regulator by turning the regulator adjustment screw fully to the bottom limit (or the throttle adjustment screw fully to the upper limit).

**FINAL CHECK**

Observe several complete ON/OFF cycles to ensure proper operation. During these cycles the electronics will determine the optimum ignition sequence timing.

1. **STOP!** Read the safety information included before proceeding.
2. Turn main valve knob to the **OFF**, full clockwise ↻ position.
3. Place ON/OFF switch (if equipped) to the **O** (OFF) position.
4. Wait a minimum of five (5) minutes to clear out any gas. Verify that no gas is in the area around the appliance, including near the floor. **If you detect gas STOP! Follow "What to do if you smell gas" in the safety information (see page 2).** If no gas is present, proceed according to the Mertik Maxitrol Operating Instructions.

**⚠ WARNING**

**Fire or Explosion Hazard.** Attempted disassembly or repair can cause property damage, severe injury or death. Do not disassemble the gas valve; it contains no serviceable components.

**MANUAL OPERATION**

(Only possible, when MANUAL knob is used)

Access to the pilot burner is only required for ignition with a match. When turning main valve knob, do not force. Knob has a slip clutch that clicks until the end stops are reached. This allows for manual flame height adjustment as well as adjustment to pilot-Standby position.

1. **STOP!** Read the safety information included before proceeding.
2. Turn main valve knob to the **OFF**, full clockwise ↻ position.
3. Turn MANUAL knob to the **MAN**, full clockwise ↻ position.
4. Place ON/OFF switch (if equipped) in **O** (OFF) position.
5. Wait five (5) minutes to clear out any gas. Verify that no gas is in the area around the appliance, including near the floor. **If you detect gas STOP! Follow "WHAT TO DO IF YOU SMELL GAS" in the safety information on page 2.** If no gas is present, proceed to step 6.

6. Place ON/OFF switch (if equipped) in **I** (ON) position.
7. With the MANUAL knob in **MAN** position a manual pilot valve operator and piezo ignitor (optional) are accessible.
8. Fully push down manual pilot valve operator and hold in, to start pilot gas flow (see figure 18, page 10).

**Ignition with match:**

Immediately light the pilot with a match, while continuing to hold in the manual pilot valve operator for about one (1) minute after the pilot is lit. Release manual pilot valve operator. If pilot does not stay lit, wait five (5) minutes and repeat.

**Ignition with piezo ignitor:**

Change the ignition cable from the receiver to the valve. Push in the piezo ignitor to ignite. If pilot does not stay lit, wait five (5) minutes and repeat.

**⚠ WARNING**

If the pilot does not stay lit after several tries, turn the gas control knob (main valve knob) to **OFF** and proceed to step 12.

9. If applicable, replace pilot access panel before proceeding.
10. Turn MANUAL knob to the **ON**, full counterclockwise ↺ position.
11. Turn main valve knob to the full **ON**, full counterclockwise ↺ position.
12. If the appliance will not operate, follow the instructions TO TURN OFF GAS TO APPLIANCE (below).

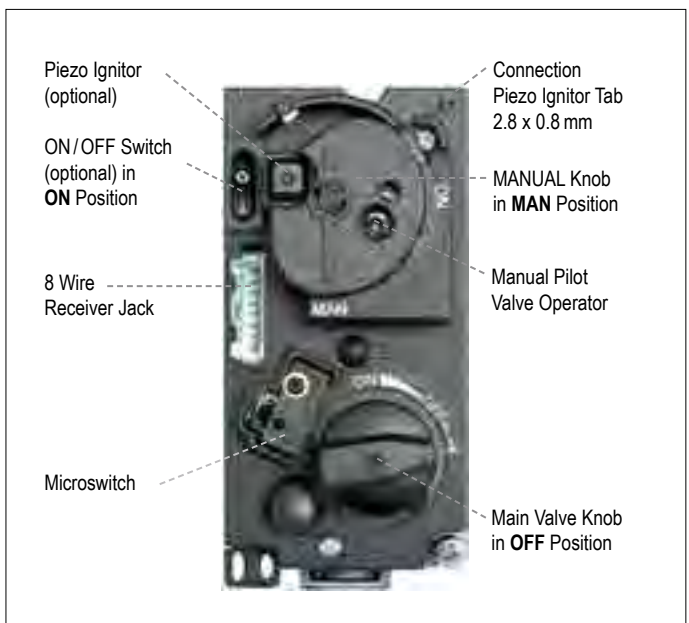

Figure 18: Combination control, cover

**TO TURN OFF GAS TO APPLIANCE**

1. Place ON/OFF switch (if equipped) in **O** (OFF) position.
2. If gas control is accessible turn main valve knob to the **OFF** full clockwise ↻ position.

**AUTOMATIC TURN DOWN TO PILOT (MOTOR ENDSTOP)**

**3 Hour No Communication Function**

- The valve will turn to pilot flame if there is no communication between handset and receiver for a 3 hour period. The fire will continue to function normally when communication is restored.

**Receiver Overheating**

The valve turns to pilot flame if the receiver temperature is higher than 176°F/80°C. If batteries are installed in the receiver the temperature must not exceed 140°F/60°C.

**1 Hour Turn Down**

(optional; requires specific handset)

- The valve will turn to pilot flame if there is no motor movement over a 1 hour period.

**NOTE:** In Manual Mode the main burner can be turned back ON after the receiver temperature is below 131°F/55°C (with batteries in receiver) or 176°F/80°C (without batteries in receiver). In Thermostatic Mode, the main burner turns back ON automatically.

**AUTOMATIC SHUT OFF**

**Countdown Timer**

- At end of Countdown Time period, the fire shuts off. The Countdown Timer only works in Manual, Thermostatic, and Eco Modes. Maximum Countdown Time is 9 hours and 50 minutes.

**Low Battery Receiver**

- With low battery power in the receiver the system shuts off the fire completely. This will not happen if the power supply is interrupted.

**On-Demand pilot**

- CSA: 7 Day Shut-Off  
CE: 5 Day Shut-Off
- This green feature eliminates gas energy consumption during extended appliance inactivity. The system automatically extinguishes the pilot when the appliance is inactive for an extended period of time. This feature helps the consumer realize cost benefits by automatically eliminating energy consumption during non-heating months and limited use.

**2<sup>nd</sup> Thermocouple Shut Off (optional)**

- The system shuts off the fire if the main burner does not completely ignite in approximately 22–29 seconds (depending if receiver PT or PT2) after ignition or after pushing ▲ button.

**NOTE:** Before the next ignition there is a 2 minute waiting period. If the thermocouple is then still too hot, you will hear a long beep.

## TOUCHPAD/WALL SWITCH

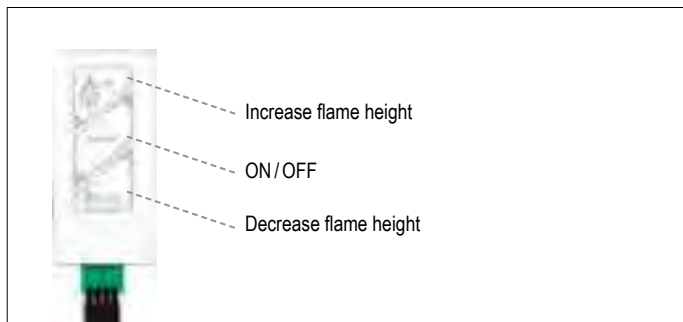

Figure 19: Touchpad/Wall Switch

### AMBIENT TEMPERATURE RANGE

- CSA: Wall Switch/Touchpad: 176 °F
- CE: Wall Switch/Touchpad: 80 °C

#### To Turn ON Appliance

- Press **ON-OFF** button (see figure 19, page 11) until two short beeps confirm the start sequence has begun; release button.
- Once pilot ignition is confirmed, there is main gas flow.

#### ▲ WARNING

If the pilot does not stay lit after several tries, turn the main valve knob to **OFF** and follow the instructions "TO TURN OFF GAS TO APPLIANCE" (see page 10).

#### Flame Height Adjustment

- Press and hold 🔥 (large flame) button to increase flame height.
- Press and hold 🔥 (small flame) button to decrease flame height or to set appliance at pilot flame.

#### Standby Mode (Pilot Flame)

- Press and hold 🔥 (small flame) button to set appliance at pilot flame.

#### To Turn OFF Appliance

#### ▲ WARNING

If the appliance will not operate, follow the instructions "TO TURN OFF GAS TO APPLIANCE" (see page 10).

- Press **ON-OFF** button.

#### TO OPEN AND CLOSE SOLENOID VALVE/BURNER

- Simultaneously press the **ON-OFF** and 🔥 (small flame) buttons to switch the decorative burner OFF.
- Simultaneously press **ON-OFF** and 🔥 (large flame) buttons to switch decorative burner on.

**NOTE:** The latching solenoid valve cannot operate manually. If the receiver battery runs down it will remain in the last operating position.

## SWITCH PANEL

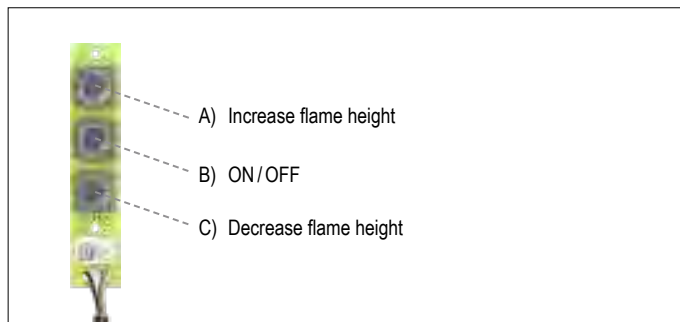

Figure 20: Switch Panel

### AMBIENT TEMPERATURE RANGE

- CSA: Switch Panel: 221 °F
- CE: Switch Panel: 105 °C

#### To Turn ON Appliance

- Press "B" button (see figure 20, page 11) until two short beeps confirm the start sequence has begun; release button.
- Once pilot ignition is confirmed, there is main gas flow.

#### ▲ WARNING

If the pilot does not stay lit after several tries, turn the main valve knob to **OFF** and follow the instructions "TO TURN OFF GAS TO APPLIANCE" (see page 10).

#### Flame Height Adjustment

- Press and hold "A" button to increase flame height.
- Press and hold "C" button to decrease flame height or to set appliance at pilot flame.

#### Standby Mode (Pilot Flame)

- Press and hold "C" button to set appliance at pilot flame.

#### To Turn OFF Appliance

#### ▲ WARNING

If the appliance will not operate, follow the instructions "TO TURN OFF GAS TO APPLIANCE" (see page 10).

- Press "B" button.

#### TO OPEN AND CLOSE SOLENOID VALVE/BURNER

- Simultaneously press the "B" and "C" buttons to switch the decorative burner OFF.
- Simultaneously press "B" and "A" buttons to switch decorative burner on.

**NOTE:** The latching solenoid valve cannot operate manually. If the receiver battery runs down it will remain in the last operating position.

## SYMAX HANDSET

The Symax System uses the same easy-to-operate logic – find the symbol for the function you want and touch that symbol – but it now has new tactile buttons for an immediate, positive response.

### TECHNICAL DATA

#### AMBIENT TEMPERATURE RANGE

CSA: Handset: 32 °F to 131 °F

CE: Handset: 0 °C to 55 °C

#### RADIO FREQUENCY

CSA: 918.0 MHz for U.S. (FCC), Canada (ISED), New Zealand (RNZ) and Australia (ACMA) (handset, receiver)

CE: 868.1 MHz for Europe (handset, receiver)

(see general radio frequency information on page 4.)

#### POWER SUPPLY

Handset: 2 x 1.5V “AAA” (quality alkaline recommended)

#### NOTICE

Wiring of valve and receiver must be completed before starting ignition. Failure to do so could damage the electronics.

#### NOTICE

The handsets and receivers are not interchangeable with previous electronics.

#### ⚠ WARNING

To avoid damaging the electronics, do NOT use metal tools to remove the batteries from the handset/receiver.

#### ⚠ WARNING

- Without using a mains adapter, battery replacement is recommended at the beginning of each heating season.
- Old or dead batteries should be removed immediately. If left in the unit the batteries can overheat, leak, and/or explode.
- Do NOT expose batteries (including during storage) to direct sunlight, excessive heat, fire, moisture, or severe impact. Each of these conditions can cause the batteries to overheat, leak, and/or explode.
- Batteries must be kept within their recommended temperature limits (ambient battery temperature range: 32 °F to 131 °F / 0 °C to 55 °C).
- New and old batteries and different brands of batteries should not be used together. Mixing of various batteries can cause the batteries to overheat, leak, and/or explode.

### SYNCHRONIZATION RECEIVER/SYMAX HANDSET

#### NOTICE



See page 7 for more information about synchronization between receiver and Symax handset.

### GENERAL NOTES



#### Batteries – Handset

Low battery indicator on handsets.

#### Software Version

Press  and  buttons simultaneously. Software version is displayed.

#### Handset Model Number

Press  and  buttons simultaneously. Handset model number is displayed.

#### Handset One Button and Two Button Ignition

Change from one button to two button ignition (Default Setting) or vice versa by pressing and holding  button for 10 sec. immediately after installing batteries. **ON** is displayed and **1** or **2** (One or Two Button Ignition) is flashing. When change is complete **1** changes to **2** or vice versa.

#### Deactivate Functions

1. Install batteries. All icons are displayed and flashing.
2. While the icons are flashing, press the relevant function button and hold for 10 sec.
3. The function icon will flash until deactivation is complete. Deactivation is complete when the function icon and two horizontal bars are displayed.

**NOTE:** If a deactivated button is pressed, there is no function, and two horizontal bars are displayed.

**NOTE:** Deactivation remains in effect after change of batteries.

#### Activate Functions

1. Install batteries. All icons are displayed and flashing.
2. To activate a function, press the relevant button and hold for 10 sec.
3. The function icon will continue to flash until activation is complete. Activation is complete when the function icon is displayed.

#### The following Functions can be Deactivated/Activated

- CHILD PROOF
- PROGRAM MODE
- THERMOSTATIC MODE (also deactivates PROGRAM MODE)
- ECO MODE
- LIGHT/DIMMER OPERATION
- CIRCULATING FAN OPERATION
- AUXILIARY FEATURE (2ND BURNER FEATURE)
- COUNTDOWN TIMER

**10-SYMBOL OPERATION**

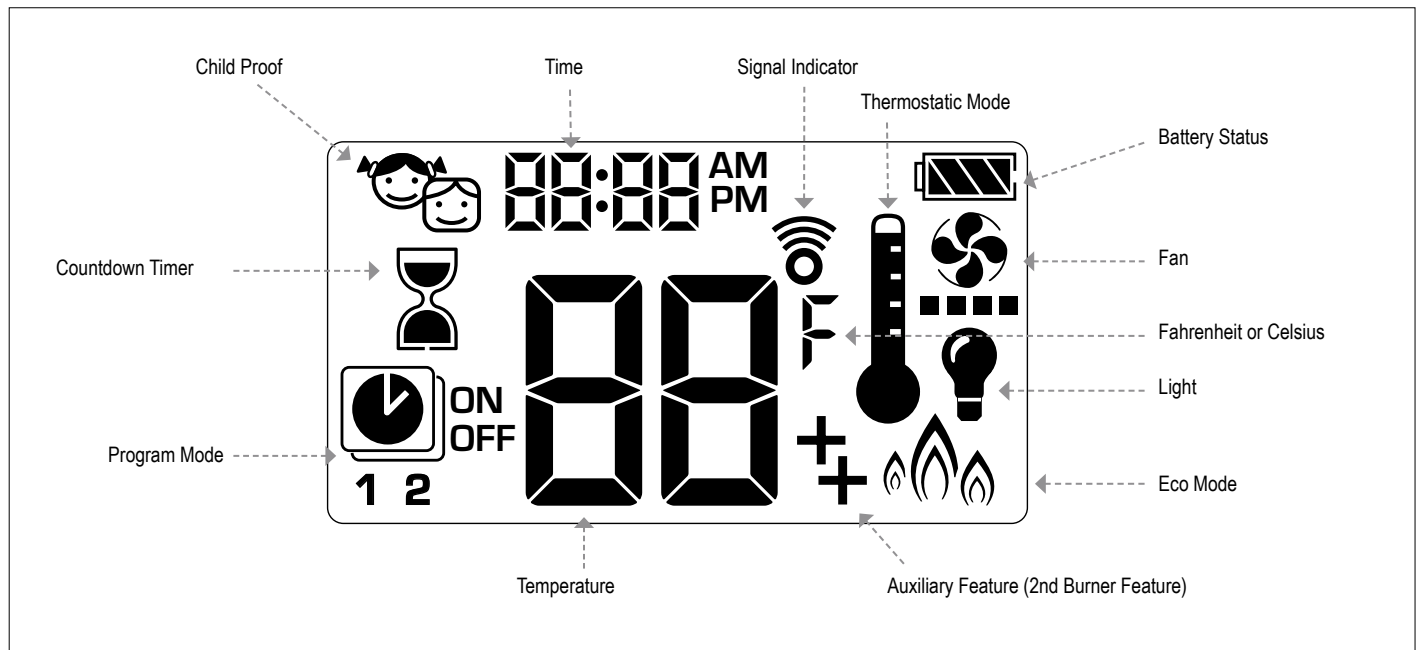
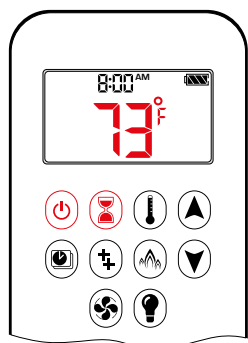

Figure 22: 10-symbol Display

**SETTING FAHRENHEIT OR CELSIUS**



To change between °C and °F, press and buttons simultaneously.

**NOTE:** Choosing °F results in a 12 hour clock. Choosing °C results in a 24 hour clock.

**CHILD PROOF**

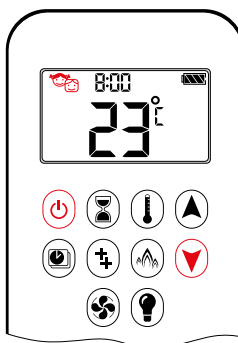

**ON:**  
To activate press and buttons simultaneously. displayed and the handset is rendered inoperable, except for the OFF function.

**OFF:**  
To deactivate press and buttons simultaneously. disappears.

**SETTING THE TIME**

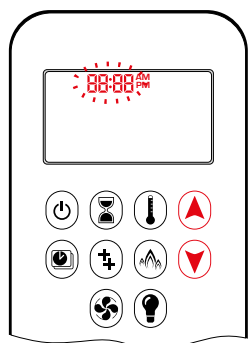

1. Press and buttons simultaneously. **Day** flashes.
2. Press or button to select a number to correspond with the day of the week (e.g. 1=Monday, 2=Tuesday, 3=Wednesday, 4=Thursday, 5=Friday, 6=Saturday, 7=Sunday).
3. Press and buttons simultaneously. **Hour** flashes.
4. To select hour press or button.
5. Press and buttons simultaneously. **Minutes** flash.
6. To select minutes press or button.
7. To confirm press and buttons simultaneously or wait.

**MANUAL MODE (HANDSET)**

**NOTICE**

**BEFORE OPERATING**

1. Make sure MANUAL knob on the GV60 valve is in the **ON**, full counterclockwise ↺ position.
2. Place the ON/OFF switch (if equipped) in the I (ON) position.

**TO TURN ON FIRE**

**▲ WARNING**

When pilot ignition is confirmed, motor turns automatically to maximum flame height.

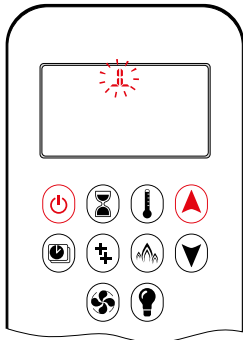

- Press ⏻ button (One Button Ignition) or ⏻ and ▲ button simultaneously (Two Button Ignition) until two short beeps and a blinking series of lines confirms the start sequence has begun; release button(s).
- Main gas flows once pilot ignition is confirmed.
- Handset automatically goes into Manual Mode after main burner ignition.

**▲ WARNING**

If the pilot does not stay lit after several tries, turn the main valve knob to **OFF** and follow the instructions “TURN OFF GAS TO APPLIANCE” (see page 9).

**STANDBY MODE (PILOT FLAME)**

**Handset**

- Press and hold ▼ button to set appliance to pilot flame.

**TO TURN OFF FIRE**

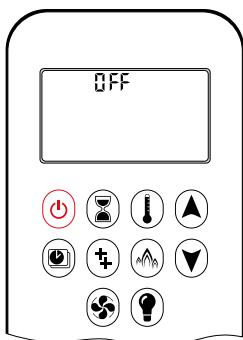

**Handset**

- Press ⏻ button to turn off.

**NOTE:** A new ignition is possible after the OFF icon stops flashing.

**FLAME HEIGHT ADJUSTMENT**

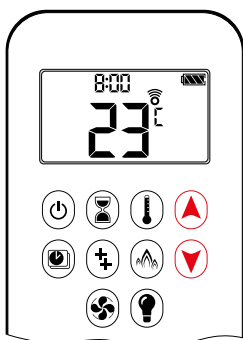

**Handset**

- To increase flame height press and hold ▲ button.
- To decrease flame height or to set appliance to pilot flame, press and hold ▼ button.

**DESIGNATED LOW FIRE AND HIGH FIRE**

**NOTE:** Backlight must be on for high fire and low fire double-click operation.

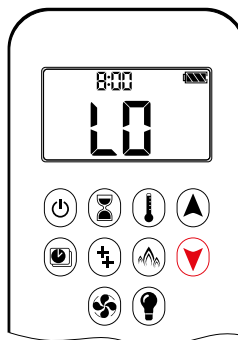

- To go to low fire, double-click ▼ button. LO is displayed.

**NOTE:** Flame goes to high fire first before going to low fire.



- To go to high fire, double-click ▲ button. HI is displayed.

**▲ WARNING**

If the appliance will not operate, follow the instructions “TURN OFF GAS TO APPLIANCE” (see page 9).

**COUNTDOWN TIMER**

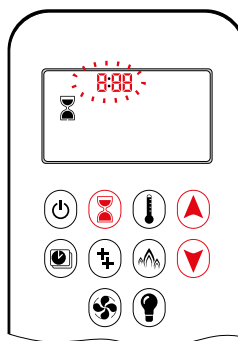

**ON/SETTING:**

1. Press and hold ⏻ button until ⏻ displayed, and **hour** flashes.
2. To select hour press ▲ or ▼ button.
3. To confirm press ⏻ button. **Minutes** flash.
4. To select minutes press ▲ or ▼ button.
5. To confirm press ⏻ button or wait.

**OFF:**

Press ⏻ button, ⏻ and Countdown Time disappear.

**NOTE:** At end of Countdown Time period, the fire shuts off. The Countdown Timer only works in Manual, Thermostatic, and Eco Modes. Maximum Countdown Time is 9 hours and 50 minutes.

**MODES OF OPERATION**

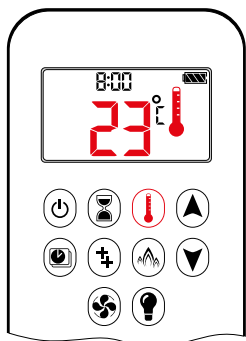

**Thermostatic Mode**

The room temperature is measured and compared to the set temperature. The flame height is then automatically adjusted to achieve the set temperature.

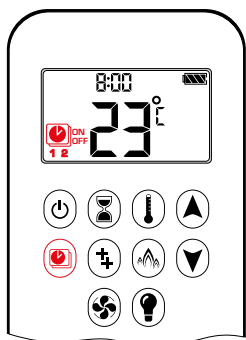

**Program Mode**

PROGRAM 1 and 2, each can be programmed to go ON and OFF at specific times at a set temperature.

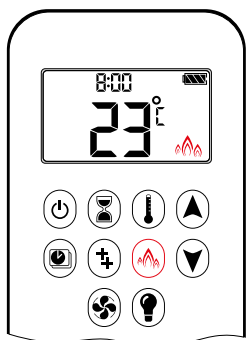

**Eco Mode**

Flame height modulates between high and low. If the room temperature is lower than the set temperature, the flame height stays on high for a longer period of time. If the room temperature is higher than the set temperature, the flame height stays on low for a longer period of time. One cycle lasts approx. 20 min.

**THERMOSTATIC MODE**

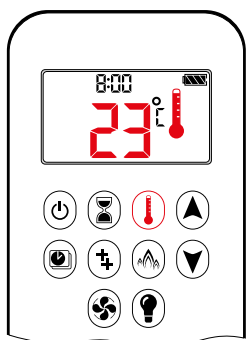

**ON:**

Press button. displayed, preset temperature displayed briefly, and then room temperature displayed.

**OFF:**

1. Press button.
2. Press or button to enter Manual Mode.
3. Press button to enter Program Mode.
4. Press button to enter Eco Mode.

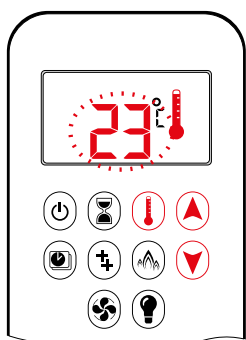

**SETTING:**

1. Press button and hold until displayed, temperature flashes.
2. To adjust set temperature press or button.
3. To confirm press button or wait.

**PROGRAM MODE**

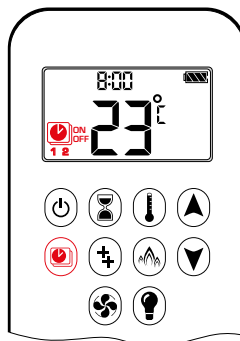

**ON:**

Press button. , **1** or **2**, **ON** or **OFF** displayed.

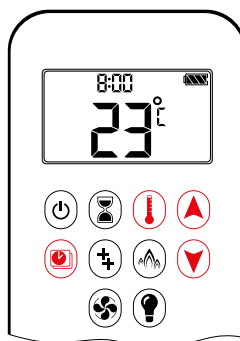

**OFF:**

1. Press or or button to enter Manual Mode.
2. Press button to enter Thermostatic Mode.
3. Press button to enter Eco Mode.

**NOTE:** The set temperature for Thermostatic Mode is the temperature for the ON time in Program Mode. Changing the Thermostatic Mode set temperature also changes the ON time temperature in Program Mode.

**Default settings:**

ON TIME (Thermostatic) TEMPERATURE: 70 °F / 21 °C  
 OFF TIME TEMPERATURE: “--” (pilot flame only)

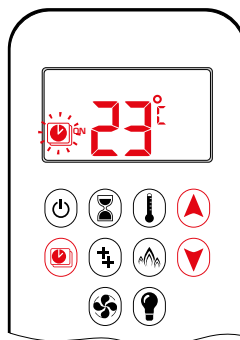

**TEMPERATURE SETTING:**

1. Press button and hold until flashes. **ON** and set temperature (setting in Thermostatic Mode) displayed.
2. To continue press button or wait. , **OFF** displayed, temperature flashes.
3. Select OFF temperature by pressing the or button.
4. To confirm press button.

**NOTE:** The ON (Thermostatic) and OFF set temperatures are the same for each day.

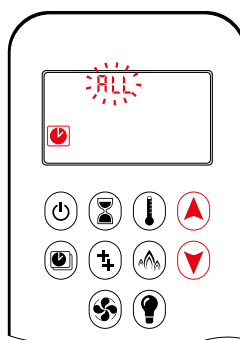

**DAY SETTING:**

5. **ALL** flashes. Press or button to choose between **ALL**, **5P:5U**, **1**, **2**, **3**, **4**, **5**, **6**, **7**.
6. To confirm press button.



**RLL SELECTED**

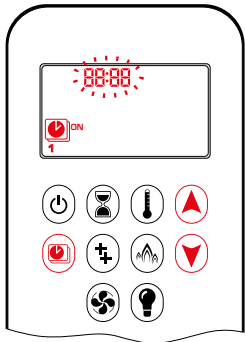

- ON TIME SETTING (PROGRAM 1):**
7. , **1 ON** displayed, **RLL** is displayed shortly, and **hour** flashes.
  8. To select hour press or button.
  9. To confirm press button. , **1 ON** displayed, **RLL** displayed shortly, and **minutes** flash.
  10. To select minutes press or button.
  11. To confirm press button.

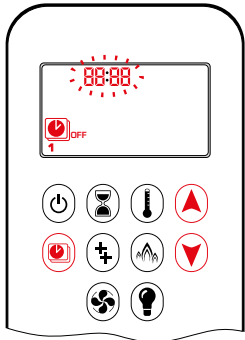

- OFF TIME SETTING (PROGRAM 1):**
12. , **1 OFF** displayed, **RLL** is displayed shortly, and **hour** flashes.
  13. To select hour, press or button.
  14. To confirm press button. , **1 OFF** displayed, **RLL** displayed shortly, and **minutes** flash.
  15. To select minutes press or button.
  16. To confirm press button.

**NOTE:** Either continue to PROGRAM 2 and set on and off times or stop programming at this point, and PROGRAM 2 remains deactivated.

**NOTE:** PROGRAM 1 and 2 use the same on (Thermostatic) and off temperatures for **RLL**, **S&S** and Daily Timer (1, 2, 3, 4, 5, 6, 7). Once a new on (Thermostatic) and/or off temperature has been set, that temperature becomes the new default setting.

**NOTE:** If **RLL**, **S&S** or Daily Timer are programmed for PROGRAM 1 and PROGRAM 2 on and off times, these become the new default times. The batteries must be removed to clear the PROGRAM 1 and PROGRAM 2 on and off times and temperatures.

**S&S or Daily Timer (1, 2, 3, 4, 5, 6, 7) selected**

- Set on time and off time using same procedure as “**RLL selected**” (above).
- **S&S**: Set on time and off time for both Saturday and Sunday.
- **Daily Timer**: Unique on and off times may be set for a single day of the week, for multiple days of the week, or for every day of the week.
- Wait to finish setting.

**AUXILIARY FEATURE (2ND BURNER FEATURE)**

The latching solenoid valve will open automatically after ignition or after switching the system off, so that the maximum flow of gas is supplied to both burners assisting with the ignition process. After pressing the AUX-button the motor will turn 7 seconds in the ON direction until the max. position is reached.

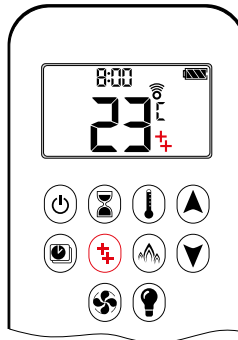

**ON:**  
To switch a burner on, press the button. displayed.

**OFF:**  
To switch the burner off, press the button. disappears.

**NOTE:** The latching solenoid valve cannot operate manually. If the receiver battery runs down it will remain in the last operating position.

**ECO MODE**

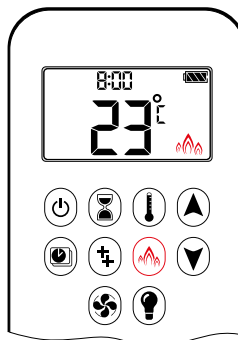

**ON:**  
Press button to enter Eco Mode. displayed.

**OFF:**  
Press button. disappears.

**CIRCULATING FAN OPERATION**

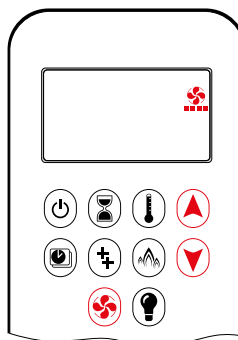

Circulating fan has 4 speed levels from low (1 bar) to high (4 bars).

- SETTING:**
1. Press button and hold until flashes.
  2. Press button to increase fan speed and button to decrease fan speed.
  3. To confirm setting either press button or wait ( displayed).

**OFF:**  
Press button until all 4 speed level bars disappear.

**NOTE:** SETTING only. If the fan was not switched off after last use, it starts automatically 4 minutes after ignition at maximum speed and goes to the last set level after 10 seconds. The fan stops 10 minutes after the gas is OFF or at pilot.

**LIGHT / DIMMER OPERATION**

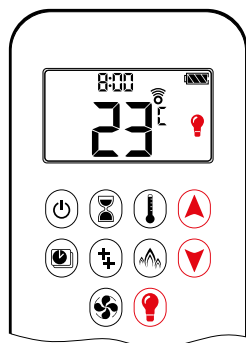

**ON:**  
Press button ( displayed). Light is on at preset level.

**OFF:**  
Press button ( disappears).

**SETTING:**

1. Press button and hold until flashes.
2. To adjust light between 20...100% press or button.
3. To confirm setting either press button or wait ( displayed).

**NOTE:** The Light works independently of the pilot flame. If you want the light on but no flame, press button.

**MYFIRE APP**

**NOTICE**

Before the app can be used, the myfire Wi-Fi Box must be wired and plugged into mains power according to myfire app setup diagram (see figure 30, page 29), and the app setup must be completed (see myfire app setup, page 24).

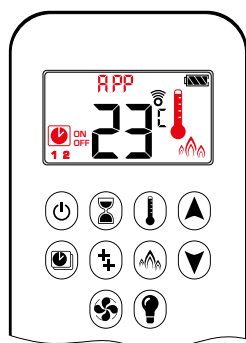

If Thermostatic, Program or Eco Mode is activated, the corresponding icon and "APP" is displayed on the handset.

The modes can be operated according to the descriptions on previous pages.

**NOTE:** In Manual Mode "APP" is NOT displayed on the handset.

## THE PUCK HANDSET

The Puck is a smart control that works in conjunction with the GV60/Symax system. Its basic functions include turning the fire on and off and turning the flame height up and down. The Puck is equipped with temperature sensing that allows the use of the popular myfire app.

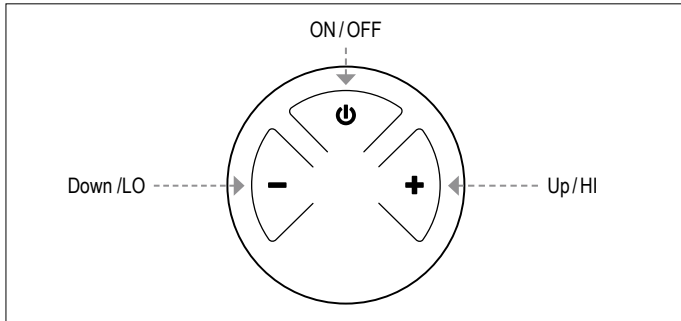

Figure 23: 3-button layout

### TECHNICAL DATA

#### AMBIENT TEMPERATURE RANGE

- CSA: The Puck: 32 °F to 131 °F
- CE: The Puck: 0 °C to 55 °C

#### RADIO FREQUENCY

- CSA: 918.0MHz for U.S. (FCC), Canada (ISED), New Zealand (RNZ) and Australia (ACMA) (The Puck, receiver)
- CE: 868.1 MHz for Europe (The Puck, receiver)  
(see radio frequency information on page 4.)

#### POWER SUPPLY

- Handset: 2 x 1.5V "AAA" (quality alkaline recommended)

#### NOTICE

Wiring of valve and receiver must be completed before starting ignition. Failure to do so could damage the electronics.

#### NOTICE

The handsets and receivers are not interchangeable with previous electronics.

#### ▲ WARNING

To avoid damaging the electronics, do NOT use metal tools to remove the batteries from the handset/receiver.

#### ▲ WARNING

- Without using a mains adapter, battery replacement is recommended at the beginning of each heating season.
- Old or dead batteries should be removed immediately. If left in the unit the batteries can overheat, leak, and/or explode.
- Do NOT expose batteries (including during storage) to direct sunlight, excessive heat, fire, moisture, or severe impact. Each of these conditions can cause the batteries to overheat, leak, and/or explode.
- Batteries must be kept within their recommended temperature limits (ambient battery temperature range: 32 °F to 131 °F / 0 °C to 55 °C).
- New and old batteries and different brands of batteries should not be used together. Mixing of various batteries can cause the batteries to overheat, leak, and/or explode.

### SYNCHRONIZATION RECEIVER/THE PUCK HANDSET

#### NOTICE

See page 7 for more information about synchronization between receiver and The Puck handset.

### MODES OF OPERATION

#### ▲ WARNING

When pilot ignition is confirmed, motor turns automatically to maximum flame height.

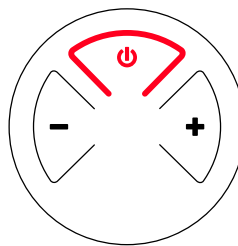

#### TURN FIRE ON AND OFF

- Press and hold the button until two short beeps confirms the start sequence has begun; release button.
- Main gas flows once pilot ignition is confirmed.
- Press and hold the button to turn OFF.

#### ▲ WARNING

If the pilot does not stay lit after several tries, turn the main valve knob to **OFF** and follow the instructions "TURN OFF GAS TO APPLIANCE" (see page 9).

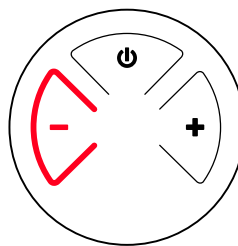

#### STANDBY MODE (PILOT FLAME)

- Press and hold the "-" button to set appliance to pilot flame

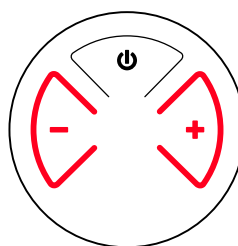

#### FLAME HEIGHT ADJUSTMENT

- To increase flame height press and hold "+" button.
- To decrease flame height or to set appliance to pilot flame, press and hold "-" button.

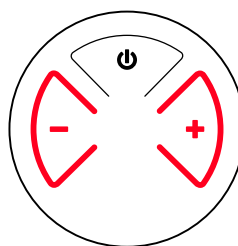

#### DESIGNATED LOW FIRE AND HIGH FIRE

- To go to hi fire, double-click "+" button.
- To go to low fire, double-click "-" button.

**NOTE:** Flame goes to high fire first before going to low fire.

#### ▲ WARNING

If the appliance will not operate, follow the instructions "TURN OFF GAS TO APPLIANCE" (see page 9).

## MYFIRE WI-FI BOX (B6R-W2...)

The second generation of the Wi-Fi Box has a faster processing speed, two RGB outlets, identical connectors on both ends of the cable, and the Wi-Fi Box itself has a much smaller footprint.

### TECHNICAL DATA

**AMBIENT TEMPERATURE RANGE**  
32°F to 176°F / 0°C to 80°C

**RADIO FREQUENCY**  
2.4 GHz (see radio frequency information on page 4.)

**POWER SUPPLY**  
6VDC powered by the receiver

**WIRELESS COMMUNICATION**

- WPA2 authentication
- AES 256-bit encryption security
- Compatible with IEEE 802.11 b/g/n

**POWER CONSUMPTION**  
Nominal: max. 0.5W  
Standby: max. 5 mA

**LED RGB CONTROL OUTPUT**  
Phoenix, 3 pol, MC 1.5/3-ST-3.5, 5VDC - 24VDC/5A

**LED RGB EXTERNAL POWER INPUT**  
Phoenix, 2 pol, MC 1.5/2-ST-3.5, 5VDC - 24VDC/5A

**APPROVALS/SDOC**  
Europe (CE); U.S. (FCC), Canada (ISED), New Zealand (RNZ), Australia (ACMA)

### MODES OF OPERATION

The myfire Wi-Fi Box communicates with a home network (Wi-Fi Router) over a wireless signal.

- The myfire Wi-Fi Box must be wired to the receiver according to the myfire app setup diagram (see figure 30, page 29)
- Connect receiver to mains power. The myfire Wi-Fi Box start with the Access Point Mode (green/blue LED blinking). Go to "myfire app setup"...

**MINIMUM REQUIREMENT FOR WI-FI ROUTER**

- IEEE 802.11n/g/b compatibility
- WPA2 encryption
- Radio frequency: 2.4 GHz band
- Wireless auto channel: Automated search for WLAN radio channel free of interference
- User Datagram Protocol (UDP) support
- multicast DNS (mDNS) for Kwik Connect process

**MINIMUM REQUIREMENT SMART DEVICE:**

- iOS 8.0 or Android 4.2

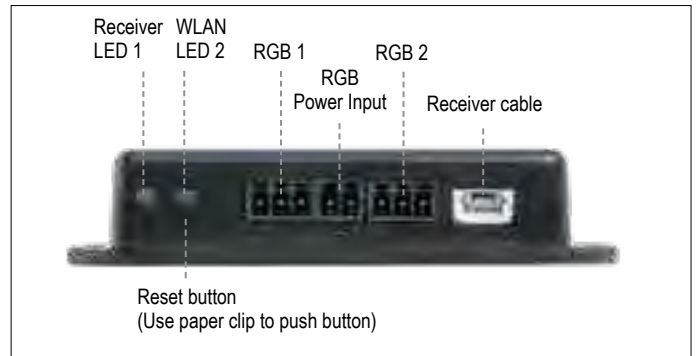

Figure 24: myfire Wi-Fi Box (B6R-W2...)

**LED INDICATION ON MYFIRE WI-FI BOX (see figure 24, page 23)**  
2 RGB LEDs

Label	LED	Status
Receiver LED 1	Green	Connected to receiver.
	Red	Not connected to receiver.
	Off	Standby mode is active or no Power supply.
WLAN LED 2	Green	Wi-Fi connection is safe.
	Blue/Green blinking	Access point mode (AP mode) is active.
	Red	Not connected to home network (Wi-Fi Router).
	Off	Standby mode is active or no power supply.

**RESET STATUS ON MYFIRE WI-FI BOX:**

Press Reset Button	LED	Function
Power-On-Reset or 1-sec-Reset	WLAN LED 2 flashes red, green and blue	If no network is set, the AP Mode will be activated for 2 hours. When the network isn't set after 2 hours, the Wi-Fi Box will go to Standby Mode. Once a network is set, the Wi-Fi Box will connect directly.
7 secs	WLAN LED 1 flashes every 500 ms in blue	Removes the Wi-Fi settings and turns on the Access point mode (AP mode) for 2 hours.
20 secs	WLAN LED 1 flashes every 50 ms in blue	Erases all Setup Data. The Wi-Fi chip will be set to the last version after the reboot. The AP-Mode will be activated for 2 hours.

### NOTICE

- A Symax handset or The Puck must be used to achieve full functionality.
- If mains power is lost, disconnect the myfire Wi-Fi Box from the receiver. This will prevent receiver batteries from being drained quickly.
- Multiple users on the same Wi-Fi channel may interfere with the data transfer. Press reset button on the myfire Wi-Fi Box for 1 second to change current channel (see figure 24, page 23).
- If no network is configured, the myfire Wi-Fi Box will leave the Access Point Mode (AP Mode) after 2 hours.
- If you have multiple fireplaces using myfire Wi-Fi Boxes, the minimum distance between the myfire Wi-Fi Boxes must be 60 cm (2'). A shorter distance may interfere with the data transfer.

### WARNING

Do not connect the combination control system to the LED connections of the myfire Wi-Fi Box.

## MYFIRE APP SETUP

### NOTICE

For myfire app setup, you will need your Wi-Fi network SSID and password.

For more detailed app setup/operating instructions refer to [www.myfireapp.com](http://www.myfireapp.com)

### INITIAL SETUP

1. Download myfire app from Apple App Store or Google Play Store.
2. Touch screen to start app setup.
3. Choose language, temperature (°C or °F) and time format (12 or 24 hour).

### REGISTRATION

**NOTE:** You must register before logging in. Registration is one time only.

1. Fill in data and accept the "Privacy Policy".
2. Touch "OK" in pop-up notice.
3. Touch link to confirm email verification.
4. You will be shown a message that you have successfully registered the myfire app.
5. Return to app.

### LOGIN

1. Fill in your registration password.
2. Accept "Terms and Conditions".
3. Touch the "Login" button.

## KWIK CONNECT

### CONNECT SMART DEVICE TO MYFIRE WI-FI BOX

1. Touch the  icon.
2. The Home Wi-Fi Network name your smart device is currently connected to is displayed.
3. Type in the password of the displayed Home Wi-Fi Network.
4. Touch "Connect". The myfire App starts connecting the myfire Wi-Fi Box to the selected Home Wi-Fi Network.

### COMPLETE MYFIRE APP SETUP

1. Type in a name for your fireplace or select an icon.
2. Activate Fan, Light and AUX if installed to your fireplace.
3. Touch "Finish" to complete the setup.

The home screen is displayed and the myfire app is ready to go.

## STANDARD SETUP

IF KWIK CONNECT IS NOT AVAILABLE, AND YOU HAVE ENTERED THE CORRECT PASSWORD, USE STANDARD SETUP.

1. Type in the password of the displayed Home Wi-Fi Network.
2. Follow the instructions on the screen and touch the "Standard Setup" button to proceed.
3. Go to your smart device Wi-Fi settings and select the myfire Wi-Fi Box network (myfire\_WiFi-Box\_<number>) you want to connect.
4. Go back to the myfire app setup and follow the instructions on the screen. Your selected Wi-Fi Box network name from the smart device Wi-Fi settings.

### USE RETRY IF PASSWORD IS INCORRECT

1. Touch the "Retry" button to repeat the Kwik Connect process.
2. Type in the correct password.

### NOTICE

To connect myfire Wi-Fi Box to Wi-Fi Router (home network), make sure:

- Home network is available.
- Home network name and password are correct.
- SSID of the Wi-Fi Router is not hidden.
- Home network signal is in range.
- Wi-Fi Router supports User Datagram Protocol (UDP).

### NOTICE

- After setting up the myfire Wi-Fi Box and myfire app, the time has to be synchronized in the settings of the myfire app.
- The active device (The Puck or Symax handset or smart device) is the one last used. An exception is if the non-active device is used to change Light, Fan, or AUX. The non-active device will make the changes, but the active device remains so if it is in Thermostatic, Program, or Eco Mode. If a Profile includes a Thermostatic, Program, or Eco setting it will also cause the active device to remain active.
- If Thermostatic, Program, or Eco Mode is activated using the app, the corresponding icon and "APP" is displayed on the Symax handset (see figure 25, page 24).
- During motor movement no information between receiver and transmitter is exchanged. The synchronization follows after motor has stopped.
- The room temperature data is transferred by the handset during synchronization.

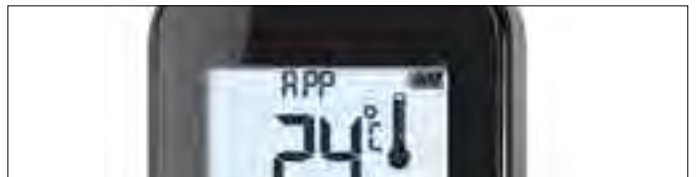

Figure 25: App connected (in Thermostatic Mode)

### NOTICE

It is the responsibility of the OEM to consider the following:

- The location of the GV60 system components will significantly effect the radio signal strength.
- The type of materials (e.g. sheet metal) used in the construction of the gas fireplace will significantly effect the radio signal strength.
- Operate the system with a dedicated mains power supply and/or batteries.
- Do not use near household electrical wiring and/or magnetic fields.
- Other transmitters using the same signal will negatively affect the radio signal strength.
- Adjustment of the on-board antenna on the receiver can improve signal strength.
- Do not store or locate the GV60 system components in a hot, cold, or humid environment.

MYFIRE APP SETUP

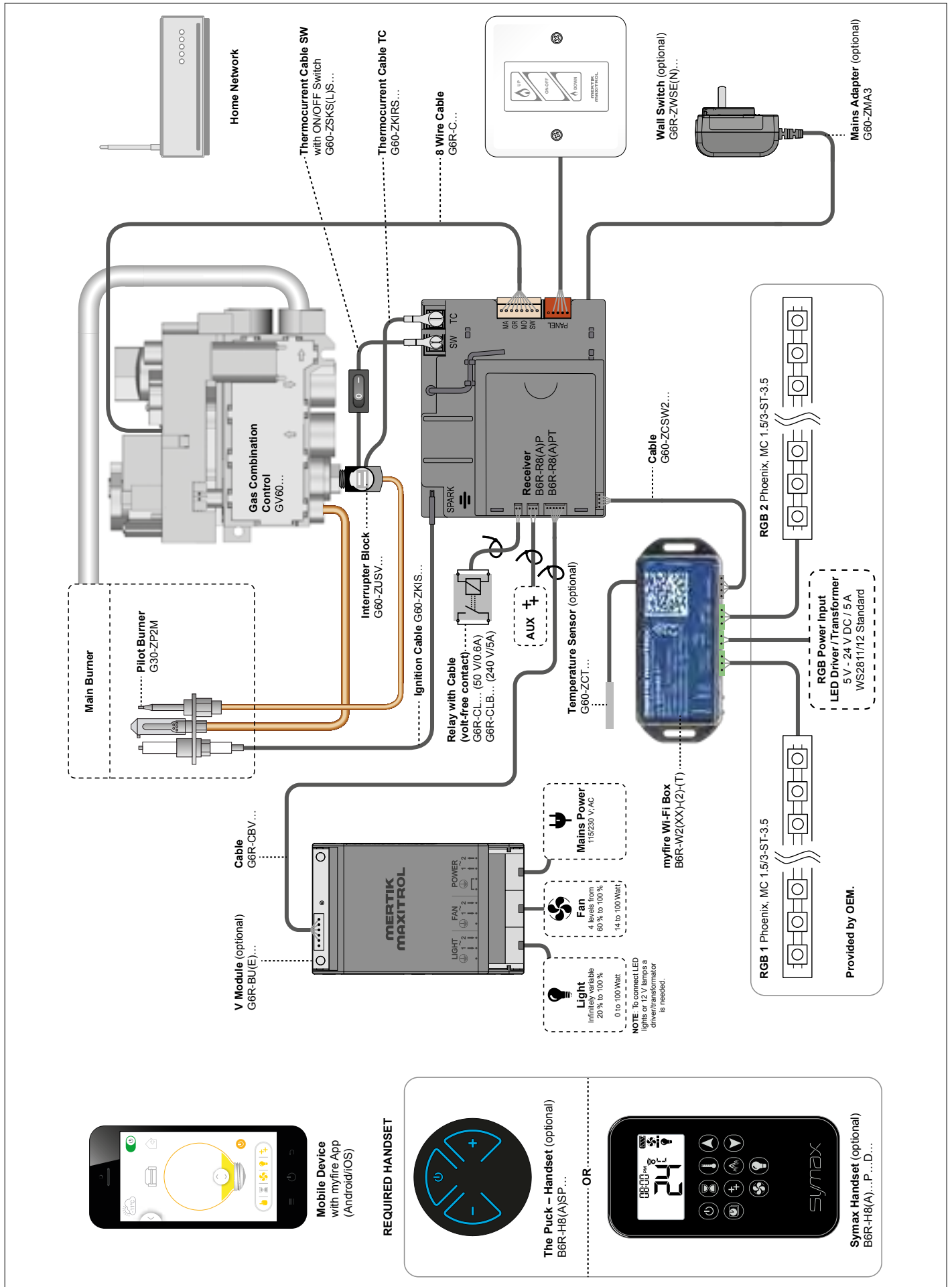

ENGLISH

Figure 30

## **MERTIK MAXITROL®**

Exclusive Distributor Europe  
for Maxitrol Company

Mertik Maxitrol GmbH & Co. KG  
Warnstedter Str. 3, 06502 Thale  
GERMANY

Tel: +49 3947 400-0  
Fax: +49 3947 400-200  
[www.mertikmaxitrol.com](http://www.mertikmaxitrol.com)

GV60-II.OI-EN-02.2019

## **MAXITROL®**

Exclusive Distributor North America  
for Mertik Maxitrol

Maxitrol Company  
23555 Telegraph Rd., PO Box 2230  
Southfield, MI 48037-2230  
USA

Tel: +1 248-356-1400  
Fax: +1 248-356-0829  
[www.maxitrol.com](http://www.maxitrol.com)