



# Meru Access Point

## Installation Guide

---

Copyright © Meru Networks, Inc., 2003-2010. All rights reserved.  
Other names and brands may be claimed as the property of others.

June 2010



## MERU NETWORKS, INC. Limited Product Warranty

This Limited Product Warranty applies to the original end-user customer of the Meru product which you purchased for your own use, and not for resale (“Product”), from Meru Networks, Inc. (“Meru”) or its authorized reseller (“Reseller”).

### Limited Warranties

- One-year limited hardware warranty: Meru warrants to you that Meru hardware (other than Third Party Products as described below) will be free from defects in materials and workmanship for a one-year period after the date of delivery of the applicable product to you from Meru or its Reseller (the “Hardware Warranty Period”). If Meru receives written notice from you of such defects during the Hardware Warranty Period, Meru will, at its option, either repair or replace Meru hardware that Meru determines to be defective. Replacement products may be remanufactured units, and will be warranted for the remainder of the original Hardware Warranty Period, or if greater, for thirty days from delivery of such replacement. Should Meru be unable to repair or replace the Meru hardware, Meru (or its Reseller, as applicable) will refund to you the purchase price of the Product.
- 90-Day Limited Software Warranty: Meru warrants to you that, for a 90-day period after the date of delivery of the applicable product to you from Meru or its Reseller (the “Software Warranty Period”), when properly installed and used, (a) the media on which the Meru software is provided will be free from defects in materials or workmanship; and (b) the Meru software will substantially conform to the functional specifications in the applicable documentation. If Meru receives written notice from you of a breach of this warranty during the Software Warranty Period and is able to reproduce the defect, Meru will, at its option, either repair or replace the defective Meru software. Should Meru be unable to repair or replace the Meru software, Meru (or its Reseller, as applicable) will refund to you the purchase price of the Product.

### Exclusions

The warranty on the Product shall not apply to defects resulting from the following:

- Alteration or modification of the Product in any way, including without limitation configuration with software or components other than those supplied by Meru or integration with parts other than those supplied by Meru.
- Abuse, damage or otherwise being subjected to problems caused by negligence or misapplication (including without limitation improper or inadequate maintenance or calibration), relocation of the products (including without limitation damage caused by use of other than Meru shipping containers), or use of the products other than as specified in the applicable Meru product documentation (including without limitation incompatible operating environments and systems), or improper site preparation or maintenance.
- Damage as a result of accidents, extreme power surge, extreme electromagnetic field, acts of nature or other causes beyond the control of Meru.
- Use of the Product with software, interfacing, parts or supplies not supplied by Meru.

The warranty on the Product does not apply if the Product is sold, or in the case of software, licensed, for free for evaluation or demonstration purposes.

Meru expressly disclaims any warranty or obligation to support the Product for all operating environments - for example, as illustration and not limitation, Meru does not warrant or ensure interoperability of the Product with future telecommunication systems or other future software or hardware.

You understand and acknowledge that the Products may generate, use or radiate radio frequency energy and may interfere with radio communications and/or radio and television receptions if is not used and/or installed in accordance with the documentation for such products. WHILE MERU USES COMMERCIALY REASONABLE EFFORTS TO ENSURE COMPLIANCE OF THE PRODUCTS WITH APPLICABLE UNITED STATES FEDERAL COMMUNICATIONS COMMISSION AND PROTECT AGAINST HARMFUL INTERFERENCES, YOU ACKNOWLEDGE AND AGREE THAT INTERFERENCES WITH RADIO COMMUNICATIONS AND/OR RADIO AND TELEVISION RECEPTIONS MAY OCCUR AND THAT MERU WILL NOT BE LIABLE FOR ANY DAMAGES OR INCONVENIENCE BASED ON SUCH INTERFERENCES.

**Third Party Products** - The above Limited Warranties are exclusive of products manufactured by third parties (“Third Party Products”). If such third party manufacturer provides a separate warranty with respect to the Third Party Product, Meru will include such warranty in the packaging of the Meru Product.

#### Return procedures

To obtain warranty service you must: (a) obtain a return materials authorization number (“RMA#”) from Meru by contacting [rmaadmin@merunetworks.com](mailto:rmaadmin@merunetworks.com), and (b) deliver the Product, in accordance with the instructions provided by Meru, along with proof of purchase in the form of a copy of the bill of sale including the Product’s serial number, contact information, RMA# and detailed description of the defect, in either its original package or packaging providing the Product with a

degree of protection equivalent to that of the original packaging, to Meru at the address below. You agree to obtain adequate insurance to cover loss or damage to the Product during shipment.

If you obtain an RMA# and return the defective Product as described above, Meru will pay the cost of returning the Product to Meru. Otherwise, you agree to bear such cost, and prior to receipt by Meru, you assume risk of any loss or damage to the Product. Meru is responsible for the cost of return shipment to you if the Meru Product is defective.

Returned products which are found by Meru to be not defective, returned out-of-warranty or otherwise ineligible for warranty service will be repaired or replaced at Meru's standard charges and shipped back to you at your expense.

At Meru's sole option, Meru may perform repair service on the Product at your facility, and you agree to provide Meru with all reasonable access to such facility and the Product, as required by Meru. On-site repair service may be available and is governed by the specific terms of your purchase.

All replaced parts, whether under warranty or not, are the property of Meru.

#### Warranty limitations

THE WARRANTIES SET FORTH ABOVE ARE EXCLUSIVE AND NO OTHER WARRANTY, WHETHER WRITTEN OR ORAL, IS EXPRESSED OR IMPLIED BY MERU, TO THE MAXIMUM EXTENT PERMITTED BY LAW. THERE ARE NO OTHER WARRANTIES RESPECTING THE PRODUCT AND DOCUMENTATION AND SERVICES PROVIDED UNDER THIS AGREEMENT, INCLUDING WITHOUT LIMITATION ANY WARRANTY OF DESIGN, MERCHANTABILITY, FITNESS FOR A PARTICULAR PURPOSE (EVEN IF MERU HAS BEEN INFORMED OF SUCH PURPOSE), TITLE OR AGAINST INFRINGEMENT OF THIRD PARTY RIGHTS. IF ANY IMPLIED WARRANTY CANNOT BE DISCLAIMED UNDER APPLICABLE LAW, THEN SUCH IMPLIED WARRANTY SHALL BE LIMITED IN DURATION TO THE HARDWARE AND SOFTWARE WARRANTY PERIODS DESCRIBED ABOVE.

NO AGENT OF MERU IS AUTHORIZED TO ALTER OR EXCEED THE WARRANTY OBLIGATIONS OF MERU.

MERU SPECIFICALLY DOES NOT WARRANT THAT THE MERU SOFTWARE WILL BE ERROR FREE OR OPERATE WITHOUT INTERRUPTION.

THE REMEDIES IN THIS LIMITED PRODUCT WARRANTY ARE YOUR SOLE AND EXCLUSIVE REMEDIES, AND MERU'S SOLE AND EXCLUSIVE LIABILITY, FOR BREACH OF THE HARDWARE OR SOFTWARE WARRANTY SET FORTH ABOVE.

#### Limitations of Liability

You acknowledge and agree that the consideration which you paid to Meru does not include any consideration by Meru of the risk of consequential, indirect or incidental damages which may arise in connection with your use of, or inability to use, the Product. **THUS, MERU AND ITS RESELLER WILL NOT BE LIABLE FOR ANY INDIRECT, INCIDENTAL, SPECIAL, PUNITIVE OR CONSEQUENTIAL DAMAGES, INCLUDING WITHOUT LIMITATION LOST PROFITS, LOST BUSINESS, LOST DATA, LOSS OF USE, OR**

COST OF COVER INCURRED BY YOU ARISING OUT OF OR RELATED TO YOUR PURCHASE OR USE OF, OR INABILITY TO USE, THIS PRODUCT OR THE SERVICES, UNDER ANY THEORY OF LIABILITY, WHETHER IN AN ACTION IN CONTRACT, STRICT LIABILITY, TORT (INCLUDING NEGLIGENCE) OR OTHER LEGAL OR EQUITABLE THEORY, EVEN IF MERU OR ITS RESELLER KNEW OR SHOULD HAVE KNOWN OF THE POSSIBILITY OF SUCH DAMAGES. IN ANY EVENT, THE CUMULATIVE LIABILITY OF MERU OR ITS RESELLER FOR ALL CLAIMS WHATSOEVER RELATED TO THE PRODUCT OR THE SERVICE WILL NOT EXCEED THE PRICE YOU PAID FOR THE PRODUCT OR SERVICES GIVING RISE TO SUCH CLAIMS.

THE LIMITATIONS SET FORTH HEREIN ARE INTENDED TO LIMIT THE LIABILITY OF MERU AND ITS RESELLERS AND SHALL APPLY NOTWITHSTANDING ANY FAILURE OF ESSENTIAL PURPOSE OF ANY LIMITED REMEDY.

The jurisdiction applicable to you may not allow the limitations of liability or damages set forth above, in which case such limitation shall only apply to you to the extent permitted in such jurisdiction.

#### Additional Information

This Limited Product Warranty shall be governed by and construed in accordance with the laws of the State of California, U.S.A., exclusive of its conflict of laws principles. The U.N. Convention on Contracts for the International Sale of Goods shall not apply.

This Limited Product Warranty is the entire and exclusive agreement between you and Meru with respect to its subject matter, and any modification or waiver of any provision of this statement is not effective unless expressly set forth in writing by an authorized representative of Meru.

All inquiries or claims made under this Limited Product Warranty must be sent to Meru at the following address:

Meru Networks Inc.,  
894 Ross Drive, CA 94087, USA

Tel: 408-215-5300

Fax: 408-215-5301

Email: [support@merunetworks.com](mailto:support@merunetworks.com)

# Contents

	<b>About This Guide</b> . . . . .	<b>.xi</b>
	Audience . . . . .	xi
	Other Sources of Information . . . . .	xi
	Meru Publications . . . . .	xi
	Website Resources . . . . .	xi
	External References . . . . .	xii
	Typographic Conventions . . . . .	xii
	Contacting Meru . . . . .	xiii
	Customer Services and Support . . . . .	xiii
	How to Get Help . . . . .	xiii
	Web Access . . . . .	xiii
	Email Access. . . . .	xiv
	Telephone Access . . . . .	xiv
	Warranty Coverage . . . . .	xiv
<b>Chapter 1</b>	<b>Access Points</b> . . . . .	<b>1</b>
	AP300 . . . . .	2
	AP320i . . . . .	4
	AP200 . . . . .	6
	AP150 . . . . .	7
	OAP180. . . . .	9
<b>Chapter 2</b>	<b>Installing AP300</b> . . . . .	<b>11</b>
	Safety Precautions. . . . .	11
	Best Practices for an AP300/AP200 Network . . . . .	12
	Unpack the AP300 . . . . .	13
	Determine Power Requirements . . . . .	14
	802.af PoE Usage . . . . .	14
	802.3at PoE Usage. . . . .	14
	Installation Requirements . . . . .	15
	Additional Equipment . . . . .	16
	Install the AP300 . . . . .	16
	Select a Location . . . . .	16
	Attach the Provided Antennas. . . . .	17
	Install the Remote Antenna Mount (optional) . . . . .	19
	Install External ACC-ANT-MIMO-MNT Antenna with Three Connectors (optional)	22
	Install Remote ACC-ANT-6ABGN-24 Antenna with Six Connectors (optional).	24
	Install Antennas With One Connector (optional) . . . . .	25
	Install the Access Point . . . . .	27

	Check AP300 LED Activity . . . . .	34
	Where to Go From Here . . . . .	36
<b>Chapter 3</b>	<b>Installing AP320i . . . . .</b>	<b>37</b>
	Safety Precautions . . . . .	37
	Best Practices for an AP320i/AP200 Network . . . . .	38
	Unpack the AP320i . . . . .	39
	Determine Power Requirements . . . . .	39
	802.af PoE Usage . . . . .	39
	802.3at Usage . . . . .	40
	Installation Requirements. . . . .	40
	Additional Equipment . . . . .	40
	Installing AP320i . . . . .	41
	Select a Location . . . . .	41
	Install the Access Point . . . . .	41
	Check AP320i LED Activity . . . . .	48
	Where to Go From Here . . . . .	51
<b>Chapter 4</b>	<b>Installing AP200 . . . . .</b>	<b>53</b>
	Safety Precautions . . . . .	53
	Unpacking the AP200 . . . . .	53
	Installation Requirements. . . . .	54
	Installing the Access Points . . . . .	56
	Selecting a Location . . . . .	56
	Attaching the AP200 Antennas . . . . .	57
	Mounting the Access Point . . . . .	57
	Where to Go From Here . . . . .	66
	Checking LED Activity . . . . .	67
	Ethernet Connector LEDs . . . . .	67
	AP200 Status LEDs . . . . .	67
<b>Chapter 5</b>	<b>Installing AP150 . . . . .</b>	<b>71</b>
	Safety Precautions . . . . .	71
	Unpacking the AP150 . . . . .	71
	Installation Requirements. . . . .	72
	Installing the Access Points . . . . .	75
	Selecting a Location . . . . .	75
	Attaching the AP150 Antennas . . . . .	76
	Mounting the Access Point . . . . .	76
	Checking LED Activity . . . . .	83
	AP150 Status LEDs . . . . .	83
	Where to Go From Here . . . . .	85



<b>Chapter 6</b>	<b>Installing OAP180 . . . . .</b>	<b>87</b>
	Safety Precautions . . . . .	87
	Unpacking the OAP180 . . . . .	88
	Installation Requirements . . . . .	88
	Installing the Access Points . . . . .	89
	Selecting a Location . . . . .	89
	Test Basic Link Operation . . . . .	91
	Mounting the Access Point . . . . .	91
	Connect Antennas and Ground Wire to OAP180 . . . . .	93
	Align Antenna . . . . .	96
	Checking LED Activity . . . . .	97
	Antenna Gain Recommendations . . . . .	98
	Where to Go From Here . . . . .	99
	 <b>Cautions and Warnings . . . . .</b>	 <b>101</b>
	Cautions . . . . .	101
	Warnings . . . . .	103
	 <b>Regulatory Information . . . . .</b>	 <b>109</b>
	For OAP180 . . . . .	109
	Radio . . . . .	109
	EMC . . . . .	109
	Safety . . . . .	109
	USA . . . . .	111
	Underwriters Laboratories . . . . .	111
	FCC Radiation Exposure Statement . . . . .	111
	Radio Frequency Interference Requirements . . . . .	111
	Canada. Industry Canada (IC) . . . . .	113
	Europe—EU Declaration of Conformity and Restrictions . . . . .	115
	IEEE 802.11a Restrictions . . . . .	117
	EEE 802.11b/g Restrictions . . . . .	117
	Japan . . . . .	118
	Singapore . . . . .	119
	Manufacturing Information . . . . .	119
	AP300 Plenum Requirements . . . . .	120



# About This Guide

This guide provides installation instructions for the Meru Access Points, which includes the AP300, AP300i, AP1000, AP200, OAP180, and AP150 models. The term access point is used interchangeably throughout this document to apply to any model when there are no differences among the models.

## Audience

---

This guide is intended for anyone installing Meru Wireless LAN System Access Points (APs).

## Other Sources of Information

---

Additional information is available in the following Meru publications, Web site, and external references.

### Meru Publications

- *Meru System Director Release Notes*
- *Meru System Director Getting Started Guide*
- *Meru Controller Installation Guide*
- *Meru System Director Command Reference*
- *Meru System Director Configuration Guide*

### Website Resources

For the first 90 days after you buy a Meru controller, you have access to online support. If you have a support contract, you have access for the length of the contract. See this web site for information such as:

- *Meru System Director Release Notes*
- Knowledge Base (Q&A)

- Downloads
- Open a ticket or check an existing one
- Customer Discussion Forum

The URL is: <http://support.merunetworks.com>

- *Meru System Director Getting Started Guide*
- *Meru Controller Installation Guide*
- *Meru System Director Release Notes*
- *Meru System Director Configuration Guide*
- *Meru System Director Command Reference*

## External References

- Stevens, W. R. 1994. *TCP/IP Illustrated, Volume 1, The Protocols*. Addison-Wesley, Reading, Mass.
- Gast, M.S. 2002. *802.11 Wireless Networks, The Definitive Guide*. O'Reilly and Associates, Sebastopol, Calif.

## Typographic Conventions

---

This document uses the following typographic conventions to help you locate and identify information:



**Note:** Provides extra information, tips, and hints regarding the topic.



**Caution!** Identifies important information about actions that could result in damage to or loss of data, or could cause the application to behave in unexpected ways.



**Warning!** Identifies critical information about actions that could result in equipment failure or bodily harm.

# Contacting Meru

---

You can visit Meru Networks, Inc. on the Internet at this URL:

<http://www.merunetworks.com>

## Customer Services and Support

For assistance, contact Meru Customer Services and Support 24 hours a day at +1-888-637-8952 (+1-888-Meru-WLA(N)) or +1-408-215-5305. Email can be sent to [support@merunetworks.com](mailto:support@merunetworks.com).

Meru Networks, Inc. Customer Services and Support provide end users and channel partners with the following:

- Telephone technical support
- Software update support
- Spare parts and repair service

### RMA Procedures

Contact Meru Customer Services and Support for a Return Material Authorization (RMA) for any Meru equipment.

Please have the following available when making a call:

- Company and contact information
- Equipment model and serial numbers
- Meru software release and revision numbers (for example, 3.0.0-35)
- A description of the symptoms the problem is manifesting
- Network configuration

## How to Get Help

---

Foundry Networks technical support will ensure that the fast and easy access that you have come to expect from your Foundry Networks products will be maintained.

### Web Access

- <https://kp.foundrynet.com>

## Email Access

Technical requests can also be sent to [support@foundrynet.com](mailto:support@foundrynet.com)

## Telephone Access

- United States: 1.877.TURBOCALL (887.2622)
- Outside the United States: 1.408.207.1600

## Warranty Coverage

---

Contact Foundry Networks using any of the methods listed above for information about the standard and extended warranties.

# Chapter 1

## Access Points

Access Points contain radio devices that communicate with the Meru Controller and form the wireless LAN (WLAN). The Meru Controller and Access Points connect to the site's wired LAN through wired switches. Wireless clients associate with the Access Points as they roam throughout the WLAN. As such, they are an extension of the wired LAN, providing the wireless benefits of client mobility, enhanced access, and dynamic network configuration.

Figure 1: Wireless LAN Connected to Network

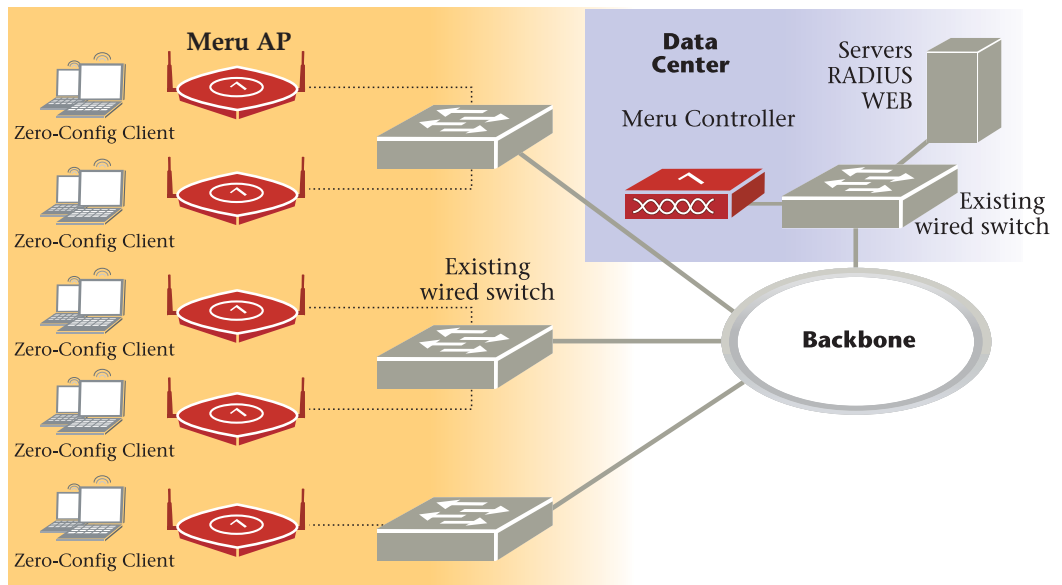

# AP300

---

The AP300 Access Point series delivers high performance, full-speed, Wi-Fi certified 802.11n based on draft 2.0 connectivity while simultaneously supporting legacy 802.11a/b/g devices. AP300 is available in the configurations shown below.

## AP300 Configurations

Model	Configuration
AP320i	Two dual-band 802.11n radios with 3x3 MIMO and internal antennas
AP320	Two dual-band 802.11n radios with 3x3 MIMO and external antennas
AP310/AP310-M	Single dual-band 802.11n radio with 3x3 MIMO and external antennas
AP311	Single dual-band 802.11n radio and single 802.11a/b/g radio (AP320 upgradable) with external antennas
AP302	Two dual-band 802.11a/b/g radios (AP320 upgrade able) with external antennas
AP301	Single dual-band 802.11a/b/g radio (AP310 up-gradeable) with external antennas

Features for the AP300 include:

- 802.11n support with channel bonding in both 2.4GHz and 5GHz frequency bands. Channel bonding combines two 20MHz channels into a single-wide 40MHz channel for increased throughput.
- Dual-band external antenna options optimized for MIMO mode
- Plug and Play deployment using centralized controller platforms
- Multi-layered security including standard WPA2, 802.11i security such as automatic traffic inspection
- Each of these Access points may be powered by a standard 802.3af PoE device.
- Air Traffic Control technology for 802.11n devices and legacy a/b/g devices
- 3x3 MIMO with 3 chains and 3 receive chains, delivering two spatial streams
- For AP302 and AP311, the a/b/g radio software upgrades to 802.11n for maximum investment protection.
- Channel span architecture which requires no channel planning or configuration
- Six standard multiband, omni-directional antennas for AP302, AP320 and AP311. Three standard multiband, omni-directional antennas for AP310/AP310-M and AP301.



- Powered by 5 volt DC input, 802.3af compliant PoE device, or draft 802.3at compliant PoE device.

Figure 2: AP300

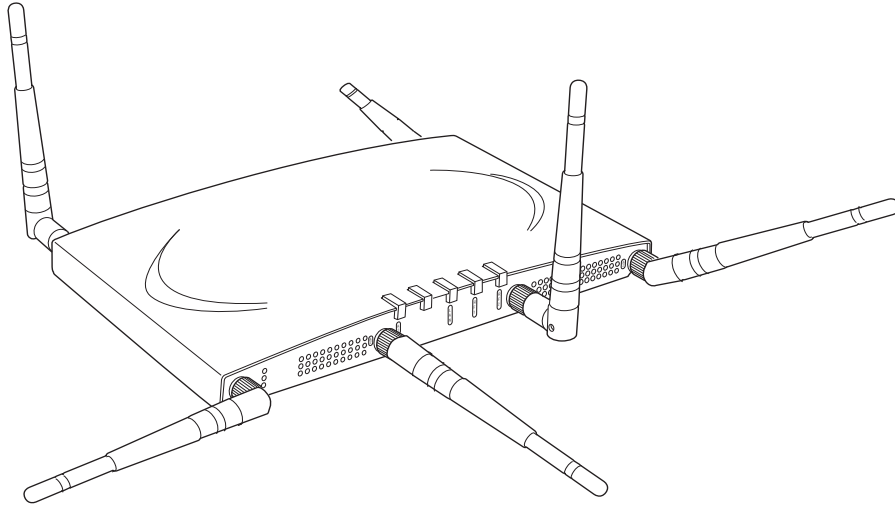

# AP320i

---

The AP320i Access Point is an internal-antenna AP with two dual-band 802.11n radios and 3x3 MIMO and internal antennas.

Features for the AP320i include:

- Internal antennas
- 802.11n support with channel bonding in both 2.4GHz and 5GHz frequency bands. Channel bonding combines two 20Mhz channels into a single-wide 40Mhz channel for increased throughput.
- Plug and Play deployment using centralized controller platforms
- Multi-layered security including standard WPA2 features such as automatic traffic inspection
- Standard 802.3af PoE support and support for many 802.3at devices
- Air Traffic Control technology for 802.11n devices and legacy a/b/g devices
- Channel span architecture that requires no channel planning or configuration

Figure 3: AP320i

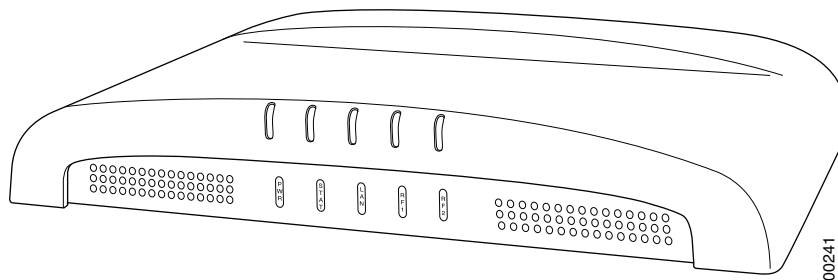

00241

# AP200

---

The AP200 series provides two models that conform to the specifications provided by the IEEE 802.11a and 802.11g protocols and provide backward compatibility for the 802.11b protocol. An AP200 works with most standard Wi-Fi clients.

- The AP201 houses a single 802.11a/b/g radio device.
- The AP208 supports a maximum of two radio devices that can simultaneously run two protocols (802.11b, g or b/g on interface 1 and 802.11a on interface 2). Alternately the second radio can be configured to run as an RF monitor to a Meru Controller, providing real-time status of RF activity to optimize the wireless network.

The AP200 series (referred hereafter as the AP200, unless specifically referring to the AP201 or AP208) is housed in a metal case with a plastic removable cover. As such, it can be used for plenum installations when the plastic cover is removed.

Figure 4: AP200

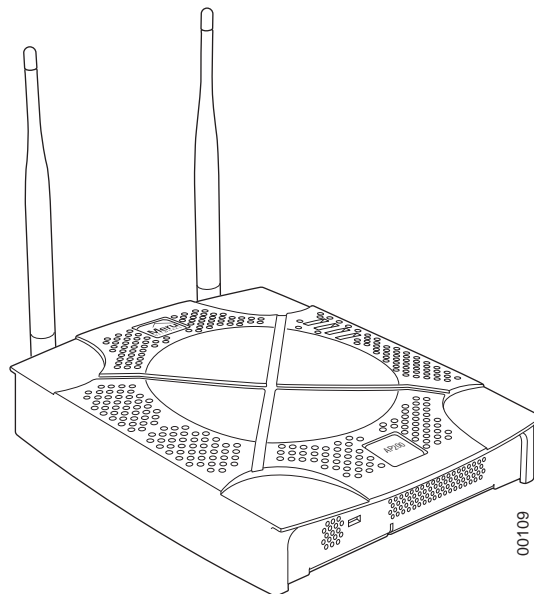

# AP150

---

The AP150 has two 802.11 radios for simultaneous 802.11a and 802.11b/g WLAN access. It is an ideal option for enterprise-wide data-only WLAN implementations and small-sized converged data and voice WLAN implementations. The AP150 works in conjunction with Meru Controller products and can be easily integrated into existing Layer 2 and Layer 3 wired network environments to provide enterprise-grade Wi-Fi access with multi-layered security options, basic VoWLAN support, centralized configuration, troubleshooting tools, remote management and RF visualization capabilities.

The AP150 has the following features:

- Dual 802.11b/g and 802.11a radios
- Simultaneously support for 802.11b, 802.11g, and 802.11a clients
- Contention Management for high density of data clients
- Basic VoWLAN QoS support for small density of voice clients
- Multiple ESSIDs with individual security policies to ensure separation of different user groups or dynamic VLAN assignment per user based on RADIUS credentials
- Zero configuration required at the access point; the installation procedure is a simple plug-n-play
- Automatic AP discovery, configuration
- Intelligent load balancing of clients
- Layer 2 or 3 connectivity for flexible deployment options
- Locking mechanism secures access point when mounted in public areas

Figure 5: AP150

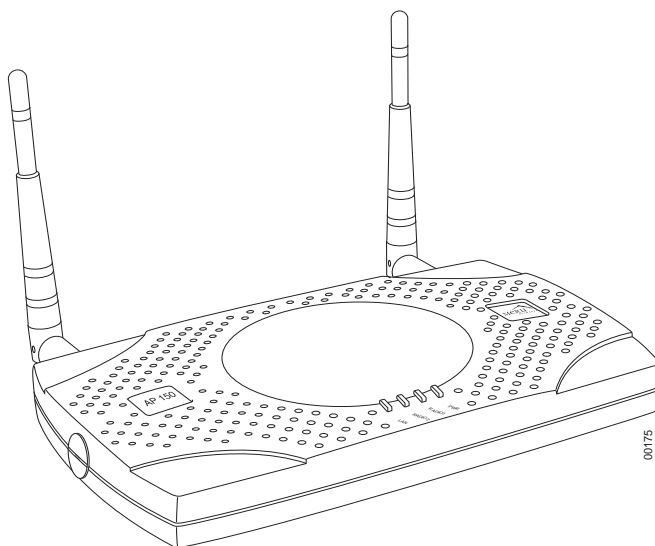

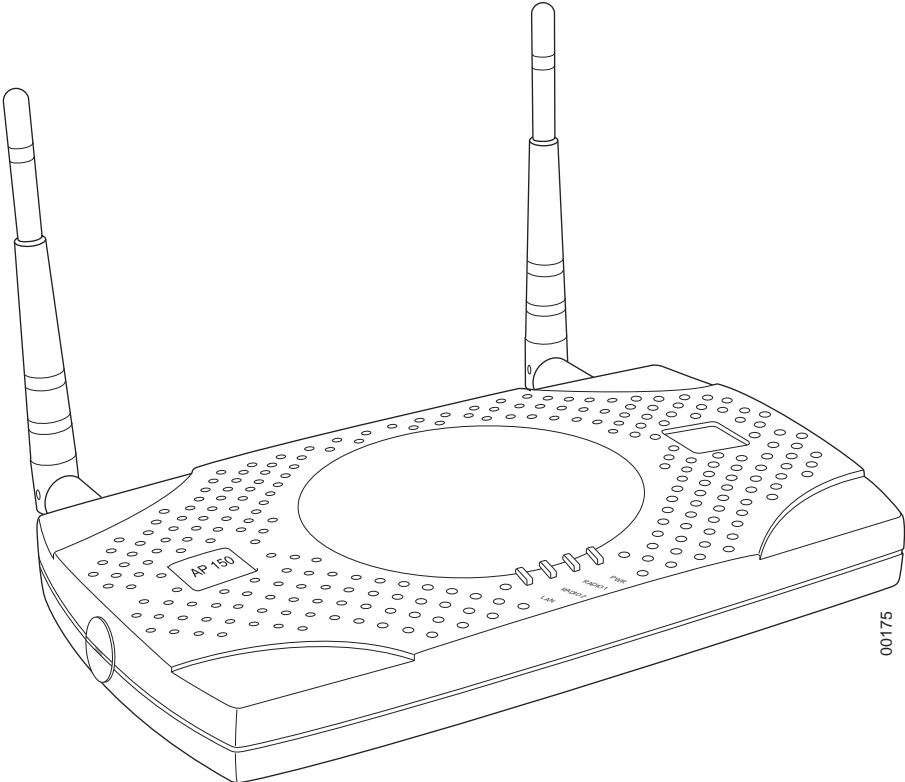

# OAP180

---

The OAP180 Rugged Access Point with dual 802.11a/bg radios is designed to provide secure Wi-Fi connectivity to outdoor locations such as campuses, parking lots, and pole tops, or to harsh indoor locations such as breweries, food processing plants or warehouses. The OAP180 supports the following features:

- Simultaneous support for 802.11a, 802.11b, and 802.11g clients using dual 802.11a and 802.11b/g radios
- Full support of System Director features
- Automatic AP discovery and configuration
- No channel planning required with single channel installations
- Intelligent load balancing of clients
- PoE (Power over Ethernet) support
- RoHS compliant
- Locking mechanism for security when mounted in public areas

Figure 6: Rugged OAP180 Access Point

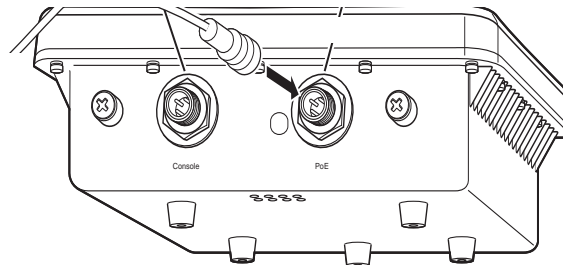



OAP180



# Chapter 2

## Installing AP300

This chapter describes how to install and configure an AP300. It contains the following sections:

- [Safety Precautions](#)
- [Unpack the AP300](#)
- [Determine Power Requirements](#)
- [Installation Requirements](#)
- [Install the AP300](#)
- [Check AP300 LED Activity](#)
- [Check AP300 LED Activity](#)
- [Where to Go From Here](#)

## Safety Precautions

---

**IMPORTANT**—Read and follow the regulatory instructions in Appendix B before installing and operating this product.

If an optional power supply is used, it must be one supplied by Meru Networks.

The AP300 is intended only for installation in Environment A as defined in IEEE 802.3af. All interconnected equipment must be contained within the same building, including the interconnected equipment's associated LAN connection.

# Best Practices for an AP300/AP200 Network

---

Read this section if you have both AP200 and AP300 active simultaneously on the same network with ABG legacy clients. The following best practices should be followed to get optimal performance from such a mixed network.

- Do not deploy AP200 and AP300 at the same physical location; we recommend no overlapping coverage between AP200 and AP300.
- If AP200 and AP300 must have overlapping coverage, make sure the ESS profiles on both AP types are unique. The chart below shows two scenarios, one supported, one not supported.
- AP300i and AP300 are interchangeable and fully compatible to share a virtual cell. It's like having two AP300s with different antennas. The only difference is that AP300i is detected as a such in the UI of the controller.

Supported Scenario	AP200 Configuration	AP300 Configuration
Two Unique ESS profiles	ESS Profile name in controller is UniqueName1	ESS Profile name in controller is UniqueName2
AP200 and AP300 SSID string over the air	Meru	Meru

Unsupported Scenario	AP200 Configuration	AP300 Configuration
Same ESS profiles	ESS Profile name in controller is same name	ESS Profile name in controller is same name
AP200 and AP300 SSID string over the air	Meru	Meru

Assumptions for the above best practices include:

- AP200 is using Virtual Port and BSSID Virtual Cell (AP200 could also be using Shared BSSID Virtual Cell.)
- AP300 is using Virtual Port BSSID Virtual Cell.
- AP200s and AP300s are on the same channel. (AP200 and AP300 could also be on different channels.)
- AP200s and AP300s are on the same controller. (AP200 and AP300 could also be on different controllers as long as each controller has a unique controller index.)

# Unpack the AP300

---

The AP300 series has five models as shown below.

Model	Radios
AP320	Two a/b/g/n
AP311	One a/b/g/n, one a/b/g
AP310/AP310-M	One a/b/g/n
AP302	One a/b/g

Confirm that the AP300 shipping package contains these items:

- AP300 with attached mounting bracket
- Six antennas
- Screws for the mounting bracket

# Determine Power Requirements

---

Power requirements vary, depending on which AP300 radios are deployed and what MIMO mode is used. See the chart below for supported power sources for different radio configurations.

Radio 1 MIMO	Radio 2 MIMO	802.3af PoE	802.3at PoE	DC Power
2x2	2x2	●	●	●
2x2	3x3	●	●	●
3x3	2x2	●	●	●
3x3	3x3	Do not recommend	Recommend with caution	●

## 802.af PoE Usage

When using System Director 3.6/4.0 and 802.3af PoE, Meru supports radios set to any MIMO settings except 3x3 on dual radios. This is because two radios set to 3x3 MIMO using an 802.3af switch may not have enough power if the cable is too long. Shorter cables frequently work, however. Meru supports:

- Single 3x3 radio
- Dual 2 x 2 radios
- Dual radio with one set to 2x2 and the other one set to 3x3

When using System Director 4.0 and 802.3af, the AP300 MIMO configuration is limited to the following:

- 3x3 for the 5 GHz radio
- 2x2 for the 2.4 GHz radio

## 802.3at PoE Usage

When using System Director 3.6/4.0 and 802.3at, the following radio combinations are recommended:

- Single 3x3 radio
- Dual 2 x 2 radios
- Dual radio with one set to 2x2 and the other one set to 3x3
- Dual 3x3 radios are recommended with a limitation. Use 802.3at power for two 3x3 MIMO radios when the switch has a high enough power output to support all devices on the PoE. Calculate the amount of power needed by each AP300/AP300i in 3x3 mode (13 watts), add that to power required by other PoE devices on the switch and compare that value to the total power output from the switch.

The calculation for 802.3at PoE use looks something like this:

$$(\text{Number of AP300s} * 13\text{watts}) + (\text{sum of all other PoE devices power requirements}) \leq \text{switch power provided}$$

## Installation Requirements

---

An array of holes on the mounting bracket allows the AP300 to be mounted on the wall and over junction boxes or molly bolts. There are holes for passing the PoE Ethernet or external power supply cable through the bracket if the bracket is mounted on a junction box. A template of this bracket is included in Appendix E of this guide.

The AP300 has a security cable slot so you can lock the AP300 with a standard security cable, such as those used to secure laptop computers.

Purchase optional mounting kits to mount the AP300 either from the ceiling or inside an enclosure:

- Suspended Ceiling Rail Mounting Kit: ACC-MNT-SCRMKIT
- Above Suspended Ceiling Mounting Kit (T-Bar Hanger): ACC-MNT-ASCMKIT
- Inside a Hoffman Enclosure using Hoffman compatible mounting bracket: ACC-AP300-BHE (enclosure not provided)
- Above hanging ceiling tiles. Suitable for use in environmental air space in accordance with the Section 300-22(c) of the National Electric Code and Sections 2- 128.12 - 010 (3) and 12 - 100 of the Canadian Electrical Code. Part 1. C22. 1.

To complete AP300 installation, you need the items listed below.

Installation Type	Items Required
Horizontal mounting	None
Vertical mounting over a wall stud	<ul style="list-style-type: none"> <li>● Two #6 x 2" wood screws for a wood stud; or</li> <li>● Two #6 x 1½" metal screws for a metal stud</li> <li>● Mounting bracket</li> </ul>
Vertical mounting on sheetrock	<ul style="list-style-type: none"> <li>● Two #6 x 1" screws</li> <li>● Two #4-6 x 7/8" ribbed plastic wall anchors</li> <li>● Mounting bracket</li> </ul>
Horizontal mounting below a hanging ceiling	<ul style="list-style-type: none"> <li>● Two caddy fasteners</li> <li>● Two plastic spacers</li> <li>● Two keps nuts (with attached lock washer)</li> <li>● Mounting bracket</li> </ul>

Install the AP300

Installation Type	Items Required
Using existing third party brackets	<ul style="list-style-type: none"><li>• Use included shoulder screws</li></ul>
Mounting above a ceiling tile	<ul style="list-style-type: none"><li>• Two T-rail clips</li><li>• One T-box hanger</li><li>• One bracket mounting clip</li><li>• Mounting bracket</li></ul>

## Additional Equipment

A power source is needed to power the AP300. See [Determine Power Requirements](#).

# Install the AP300

---

[Select a Location](#)

[Attach the Provided Antennas](#)

[Install the Remote Antenna Mount \(optional\)](#)

[Install External ACC-ANT-MIMO-MNT Antenna with Three Connectors \(optional\)](#)

[Install Remote ACC-ANT-6ABGN-24 Antenna with Six Connectors \(optional\)](#)

[Install Antennas With One Connector \(optional\)](#)

[Install the Access Point](#)

## Select a Location

All AP300 interconnected equipment, including the associated LAN connection, must be contained within the same building. In addition, the AP300 location should meet the following conditions:

- Relatively unobstructed access to the stations the AP serves. Select a location with minimal physical obstructions between the AP and the wireless stations. In an office with cubicles, mounting the APs below a hanging ceiling (plenum is supported) or the wall near the ceiling provides the least obstructed communications path. On a wall, orient the AP300 horizontally so that you can read the Meru logo without tilting your head at 90 degrees - this orientation provides optimum MIMO performance.
- Access to wall outlet or a Power over Ethernet (PoE) connection to the network switch servicing the controller.

AP300 is designed to provide 360 degree omni-directional coverage as illustrated below.

Figure 8: Coverage Pattern for AP300 When Ceiling Mounted

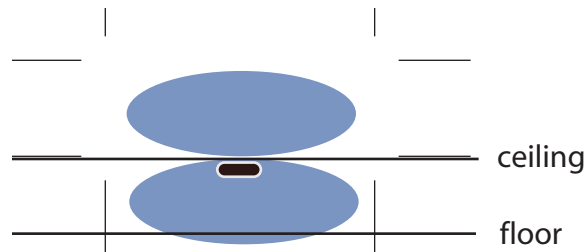

Most installations receive the best coverage using the following guidelines:

- Install APs toward the center of the building.
- Place APs about 80 feet apart.
- Do not install APs near metal objects, such as heating ducts, metal doors, or electric service panels.
- For best coverage, orient antennas as shown in [Figure 6](#).

## Attach the Provided Antennas

All AP300s have six external antenna ports, labeled 1 - 6. These units operate with six antennas attached, even though some configurations don't use all six. Instead of attaching an antenna, you can cap unused antenna connectors with 50 ohm Reverse Polarity SMA terminators. (For a list of approved terminators, see <http://www.merunetworks.com/merusupport>.) Meru supplied antennas are suitable only for indoor use unless they are mounted in an outdoor enclosure (see [Mount AP300 in a Hoffman Enclosure](#)). To achieve the best performance from your AP300, position antennas at a 90 degree angle relative to each other as shown in [Figure 6](#). The antennas do not have to be oriented exactly as shown in the figure, but it is important to maintain the relative angles. If for some reason you are unable to maintain those angles, the network still operates, but you may experience up to 20% drop in throughput depending on the antenna orientation.

**Figure 6: AP320, AP311 or AP302 Antennas 1-6 in Ceiling and Wall Mount Configuration**

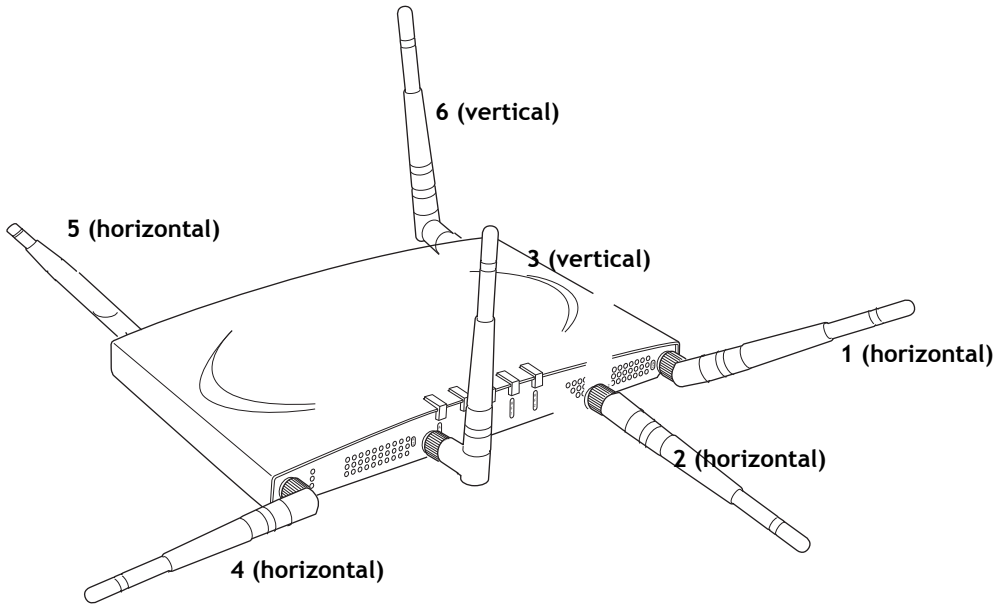

The following antenna connections are used during operation of the AP320, AP311, and AP302.

**Table 1: AP300 Radios and Corresponding Antennas**

Model	Radio 1 (Ant4, Ant5, Ant6)	Radio 2 (Ant1, Ant2, Ant3)
AP320	a/b/g/n with 3 dual band omni-directional antennas	a/b/g/n with 3 dual band omni-directional antennas
AP311	a/b/g/n with 3 dual band omni-directional antennas	a/b/g with 3 dual band omni-directional antennas
AP310/AP310-M	a/b/g/n with 3 dual band omni-directional antennas	NA
AP302	a/b/g with 3 dual band omni-directional antennas	a/b/g with 3 dual band omni-directional antennas

The AP310/AP310-M has six external antenna ports labeled 1 - 6. However, AP310/AP310-M uses only three of those antennas and the unused antenna connectors are blocked.

[Figure 7](#) illustrates the recommended antenna configuration for the AP310/AP310-M.



Figure 7: AP310/AP310-M Antennas 1-3

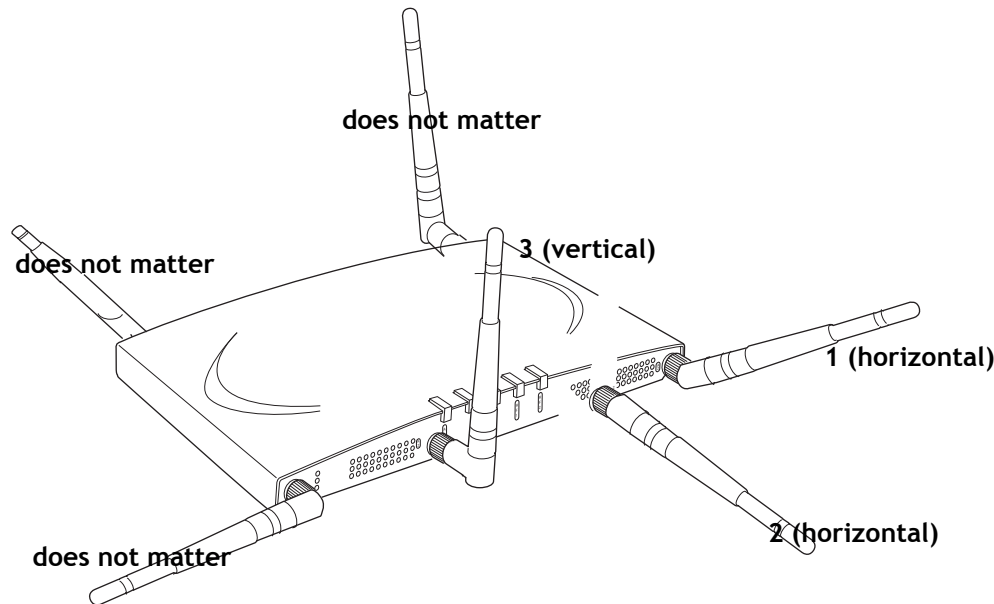

The following antenna connections are used during operation of the AP310/AP310-M.

Radio 1 Antenna Connectors for AP310/AP310-M	Radio2 Antenna Connectors for AP310/AP310-M
Ant1, Ant2, Ant3	NA

Do not leave any antenna connectors unterminated. All connectors on the AP must be terminated with antennas or with 50 ohm Reverse Polarity SMA terminators. (For a list of approved terminators, see <http://www.merunetworks.com/merusupport>.)

The attached antennas must be the same model; if you replace one antenna, replace them all.

## Install the Remote Antenna Mount (optional)

Use the optional Meru Remote Antenna Mount (ACC-ANT-MIMO-MNT) for one or both AP300 radios to remotely connect the AP300 antennas. The Remote Antenna Mount allows you to relocate either your current antennas or the optional high-gain dipole antennas to a location with clearer signal paths to the other wireless devices in your network. The Remote Antenna Mount can be installed either below the ceiling tile or on the wall. The default orientation for the mount is suitable for a ceiling mount, but you can attach the mount to a wall with some modifications.

Use one mount per radio; for example AP310/AP310-M needs one unit, and AP320 needs two units. The Remote Antenna Mount uses low-loss plenum rated LMR195 cable and SMA connectors. To order this unit, contact your Meru sales representative and refer to part number ACC-ANT-MIMO-MNT.

Install the AP300

Figure 8: Remote Antenna Mount

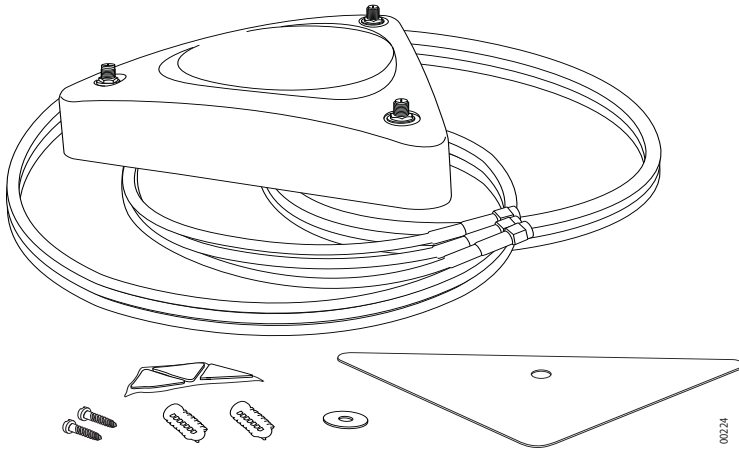

The remote antenna mount kit includes:

- Antenna stand with attached cable. The three antenna SMA female connectors on the Antenna Mount support AP300 antenna diversity. This feature gives the client the ability to automatically choose the antenna receiving the strongest signal.
- Triangular ceiling mount clip for attaching to hanging ceiling (includes bolt assembly)
- Three self-adhesive pads for the bottom of the unit (over the screws)
- Two wall mount screws with anchors
- Ceiling Mount Template
- Installation diagram

## Install the Remote Antenna Mount on the Ceiling

To connect the Remote Antenna Mount to the ceiling, refer to the installation diagram from the shipping box while following these steps:

1. Attach the shorter end of the screw to the center hole on the back of the Antenna Mount.
2. Remove the designated ceiling tile.
3. Using the template, drill holes in the ceiling tile.
4. Replace the ceiling tile.
5. Remove a ceiling tile adjacent to the newly drilled tile for access purposes.
6. Feed the Antenna Mount cable through the larger hole in the ceiling tile until the Antenna Mount is flush with the ceiling. The screw should now be visible above the ceiling tile (through the second hole).
7. Place the triangular plate above the ceiling tile with the screw aligned through the plate.
8. Drop the washer onto the screw and tighten the bolt.  
The Antenna Mount is now connected to the ceiling.
9. Replace the adjacent tile.

10. Connect the three Remote Antenna Mount cables to the appropriate connectors on the AP300. Be sure to connect the three antennas that correspond to one radio. Radio 1 uses A1, A2, A3 and Radio 2 uses A4, A5, A6.

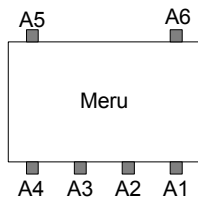

11. Attach three antennas that shipped with AP300 to the three connectors on the triangular remote device. See [Figure 8](#).

## Install the Remote Antenna Mount on a Wall

1. Reorient the cable on the Remote Antenna Mount by removing the three screws on the back, removing the small cover, reorienting the cable and then replacing the three screws. Discard the small cover.
2. Connect the three Remote Antenna Mount cables to the appropriate ports on the AP300. Be sure to connect the three antennas that correspond to one radio. With dual radio, Radio 1 uses A4, A5, A6 and Radio 2 uses A1, A2, A3. For AP310/AP310-M, the single radio uses A1, A2, A3.

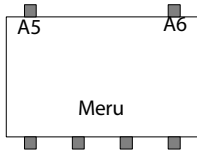

A4 A3 A2 A1

3. Attach three of the antennas that shipped with AP300 to the three ports on the triangular remote device.
4. Orient the connected AP300 horizontally so that you can read the Meru logo without tilting your head at 90 degrees - this orientation provides optimum MIMO performance.

## Install External ACC-ANT-MIMO-MNT Antenna with Three Connectors (optional)

You can optionally use an external antenna setup with your AP300 if the controller and APs are running System Director 3.6.1MR4 and later. Meru supports this antenna for use on one radio using 802.11n MIMO. An AP300 with one radio, for example AP310/AP310-M, needs one antenna. An AP300 with two radios, for example AP320, needs two antennas. Radio One cables connect to ports A1, A2, and A3. Radio Two cables connect to ports A4, A5, and A6. There is no preferred cabling connection; all three cables are the same.

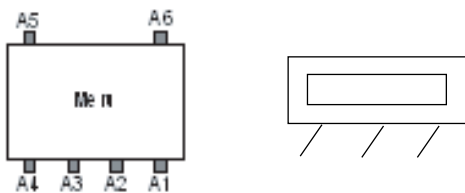

Calculate the antenna gain for the ACC-ANT-MIMO-MNT antenna by referring to the next three charts:

Band of Operation	Gain	Vertical Beamwidth	Horizontal Beamwidth
2.40-2.483 GHz	2.5dB	55 degrees	360 degrees
5.15-5.85 GHz	4dB	60 degrees	360 degrees

Using This Cable Type with 2.4 GHz	Calculate This Loss per Foot
RG174	0.60 dB
RG316	0.48 dB
LMR100	0.39 dB
LMR200	0.17 dB
LMR240	0.13 dB
LMR400	0.066 dB
LMR600	0.043 dB

Using This Cable Type with 5 GHz	Calculate This Loss per Foot
RG174	1.02
RG316	0.76
LMR100	0.59 dB
LMR200	0.24 dB
LMR240	0.19 dB
LMR400	0.100 dB
LMR600	0.066 dB

## Install Remote ACC-ANT-6ABGN-24 Antenna with Six Connectors (optional)

You can optionally use an external antenna setup with your AP300 if the controller and APs are running System Director 3.6.1MR4 and later. Meru supports this antenna for use on AP300s with two radios, for example AP320. This antenna has six connectors to connect to both radios to a dual-radio AP300 and it supports 802.11n MIMO operation.

The six cables on the ACC-ANT-6ABGN-24 antenna are already tagged with the numbers 1 - 6. Connect the antenna cables to the AP antenna ports as shown here:

Meru AP300 Antenna Connector	Antenna Cable Numbered
A1	6
A2	5
A3	4
A4	3
A5	2
A6	1

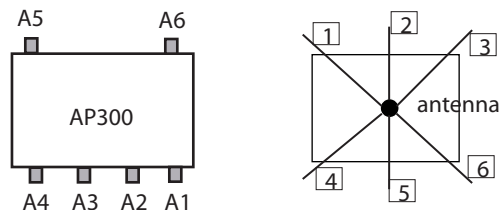

Calculate the antenna gain for the ACC-ANT-6ABGN-24 antenna by referring to the next three charts:

Band of Operation	Gain	Vertical Beamwidth	Horizontal Beamwidth
2.40-2.483 GHz	2.5dB	55 degrees	360 degrees
5.15-5.85 GHz	4dB	60 degrees	360 degrees

Using This Cable Type with 2.4 GHz	Calculate This Loss per Foot
RG174	0.60 dB
RG316	0.48 dB
LMR100	0.39 dB
LMR200	0.17 dB
LMR240	0.13 dB
LMR400	0.066 dB
LMR600	0.043 dB

Using This Cable Type with 5 GHz	Calculate This Loss per Foot
RG174	1.02
RG316	0.76
LMR100	0.59 dB
LMR200	0.24 dB
LMR240	0.19 dB
LMR400	0.100 dB
LMR600	0.066 dB

## Install Antennas With One Connector (optional)

You can optionally use an external antenna setup with your AP300 if the controller and APs are running System Director 3.6.1MR4 or 4.0.

When deploying an AP300 with only one antenna per radio, AP300 cannot support 802.11n MIMO operation. Also, any antenna ports that are not used to connect to an antenna must be terminated with 50 ohm Reverse Polarity SMA terminators. (For a list of approved terminators, see <http://www.merunetworks.com/merusupport>.) Connect the antenna using one cable per radio as described in the table below. These instructions can be used to replace an AP200 existing antenna configuration with an AP300. For these instructions, each port on the AP300 is identified by a label A1 to A6.

### AP Has One BG or A Radio, One Antenna



### AP Has Two Radios (BG and A), One Antenna For Each

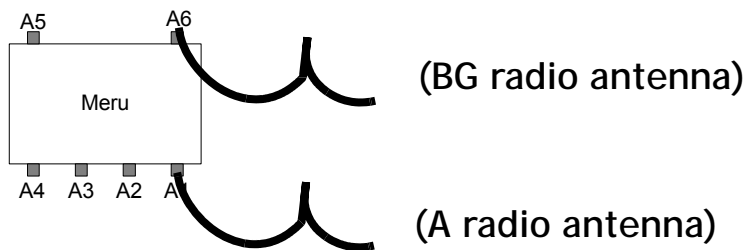

### AP Has One Radio, Two Antennas

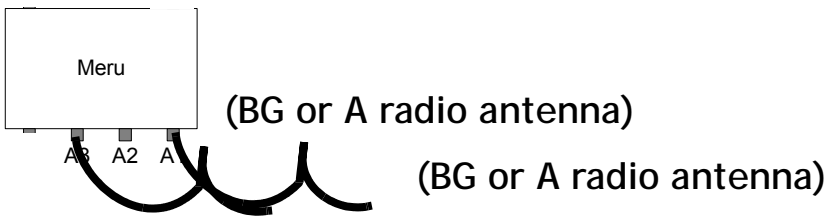

### AP Has Two Radios, Four Antennas

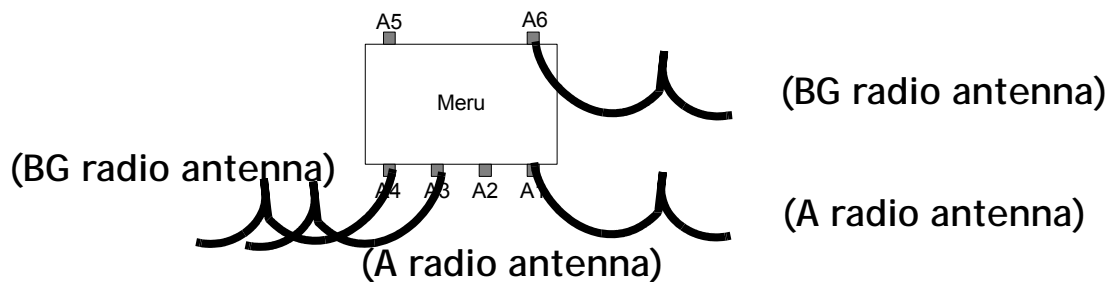



## Install the Access Point

AP300 ships with a detachable mounting bracket. The AP300 is designed to be compatible with brackets supplied by Meru and by other vendors as follows. The AP300 mounts directly on the AP150 mounting bracket. If you are replacing AP200s/AP300s, the AP300 bracket can be mounted on the old AP200s/AP300s bracket with included shoulder screws; you don't need to remove the old brackets. AP300 can also be directly mounted on third-party brackets such as Proxim AP4000 and Cisco standard brackets.

You can mount an AP300 in the following ways:

- [Mount AP300 Horizontally on a Shelf](#)
- [Mount AP300 Vertically on a Wall](#)
- [Mount AP300 Below a Suspended Ceiling](#)
- [Mount AP300 Above a Suspended Ceiling \(Plenum\)](#)
- [Mount AP300 in a Hoffman Enclosure](#)

### Mount AP300 Horizontally on a Shelf

When mounting an AP300 horizontally, remove the mounting bracket. Be sure to position the antennas vertically when an AP300 sits on a surface.

### Mount AP300 Vertically on a Wall

 **Note:** If you are replacing AP150s, you can use the existing brackets: the AP150 and AP300 use the same bracket. If you are replacing AP300s, the AP300 bracket can be attached to the old bracket with included shoulder screws; you don't have to remove the old brackets. This bracket will also mount seamlessly into the Proxim AP4000 bracket and standard Cisco brackets.

To mount an AP300 on a wall:

1. Using the bracket holes as a guide, mark the location on the wall for the two AP bracket mounting screws. If possible, center the mounting screws on a wall stud. If you do not center the mounting screws on a wall stud, use plastic wall anchors. Orient the AP300 horizontally so that you can read the Meru logo without tilting your head at 90 degrees - this orientation provides optimum MIMO performance.
2. Drill holes at the locations you marked:
  - 3/16-inch holes if you are using plastic anchors
  - 1/8-inch holes if you are using only the screws
3. If you are using plastic anchors, install them in the holes.
4. Screw in the screws most of the way.
5. Mount the bracket on the screws, placing the circular portion of the keyhole mount over the screw heads and sliding the bracket down.
6. Connect one end of the Ethernet cable to the switch and the other end to the AP300 Ethernet port.

**!** **Caution!** Be sure to connect the Ethernet cable to the Ethernet port; the cable can mistakenly be plugged into the Console port. If you do this, the AP won't power up.

7. If you are not using a PoE device, connect an external power supply to the power connector and plug it into the wall.

## Mount AP300 Below a Suspended Ceiling

The optional suspended ceiling mounting kit (ACC-MNT-SCRMKIT) allows the AP300 mounting bracket to attach to suspended ceiling T-rails (see [Figure 9](#)).

**✓** **Note:** To comply with NEC code, attach a grounding wire to any of the screws used to attach the AP300 to the mounting bracket.

Figure 9: Mounting any AP to a Suspended Ceiling Rail using ACC-MNT-SCRMKIT

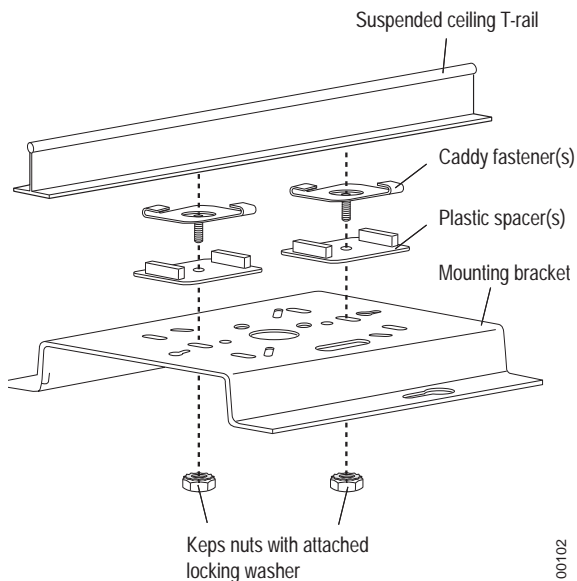

To mount an AP300 below a suspended ceiling:

1. Determine the location on the ceiling rail where the AP will be mounted and remove the ceiling tiles.
2. Place each of the two caddy fasteners on the ceiling T-rail and twist to attach to the rail.
3. Adjust the distance between the caddy fasteners by using the mounting bracket holes as a guide.
4. Tighten the caddy fasteners in place using a standard screwdriver. Do not overtighten.
5. Place each spacer on the caddy fastener stud. The spacer legs should contact the ceiling T-rail.
6. Align the mounting bracket keyholes with the caddy fastener studs and slide the AP300 to the narrow end of the hole.
7. Attach a keps nut to each caddy fastener stud and hand tighten. Do not overtighten.

8. Align the AP300 mounting posts over the circular portion of the keyhole mounts, push the AP in and slide the AP down until it engages with the locking detents (see [Figure 9](#)). You should hear it snap in place.
9. For each antenna, loosen the knurled ring at the base of the antenna, orient the antenna and then retighten the ring.
10. Connect one end of the PoE 100BaseT Ethernet cable to the 100/1000 Ethernet connector.



**Caution!** Be sure to connect the Ethernet cable to the Ethernet port; the cable can mistakenly be plugged into the Console port. If you do this, the AP won't power up.

## Mount AP300 Above a Suspended Ceiling (Plenum)

Use the optional T-bar box hanger mounting kit (see [Mounting Brackets](#) for the part number) to mount AP300 above suspended ceiling T-rails (see [Figure 10](#) and [Figure 11](#)). The installation attaches the T-bar box hanger to the ceiling rails and then the AP300 attaches to the T-bar box hanger. We recommend that you mount the AP300 no more than half way up the supports as shown in both [Figure 10](#) and [Figure 11](#). Also note that AP300 mounted above the ceiling has about 2-3 dBm less RF coverage than AP300 mounted under the ceiling.

Figure 10: AP300 Mounted Above a Suspended Ceiling Face Down

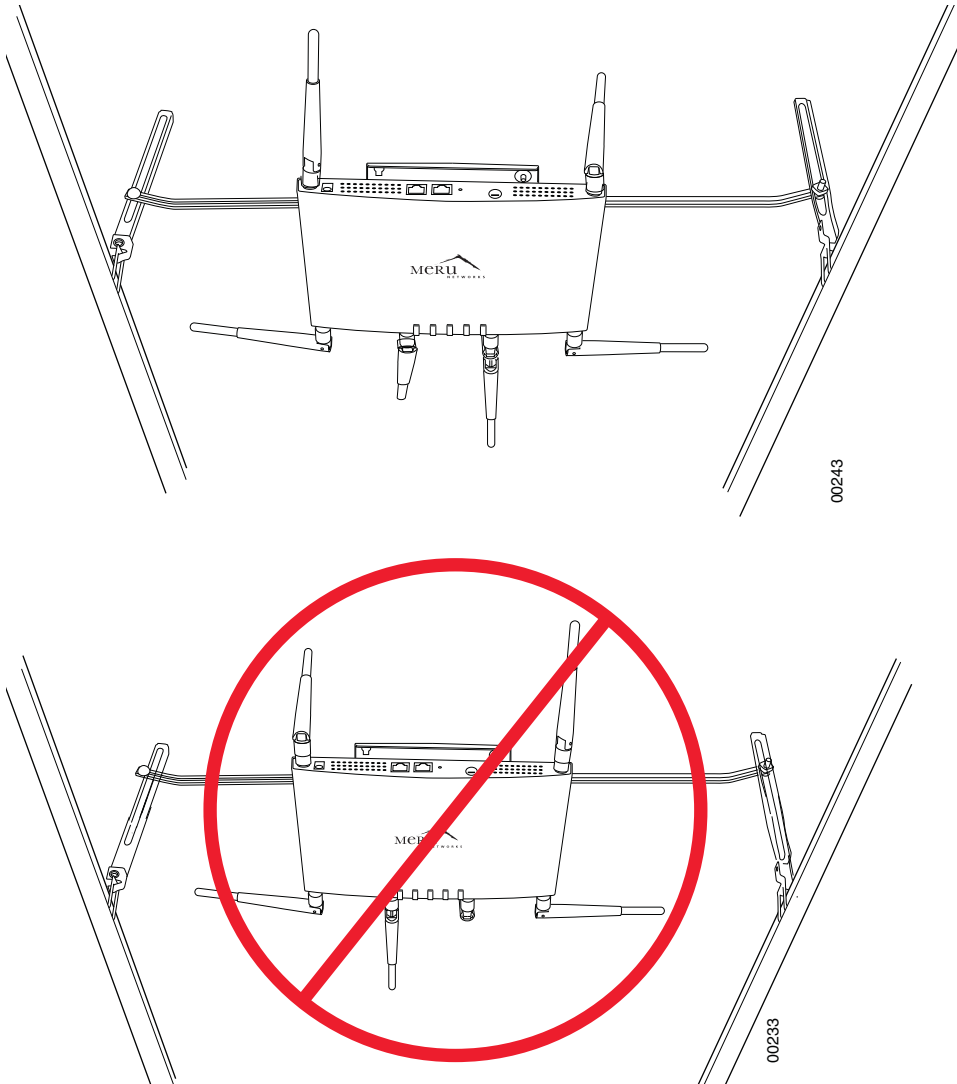

The second example above is mounted too high on the support rails, which could cause the rails to bend.

Figure 11: AP300 Mounted Above a Suspended Ceiling Face Up

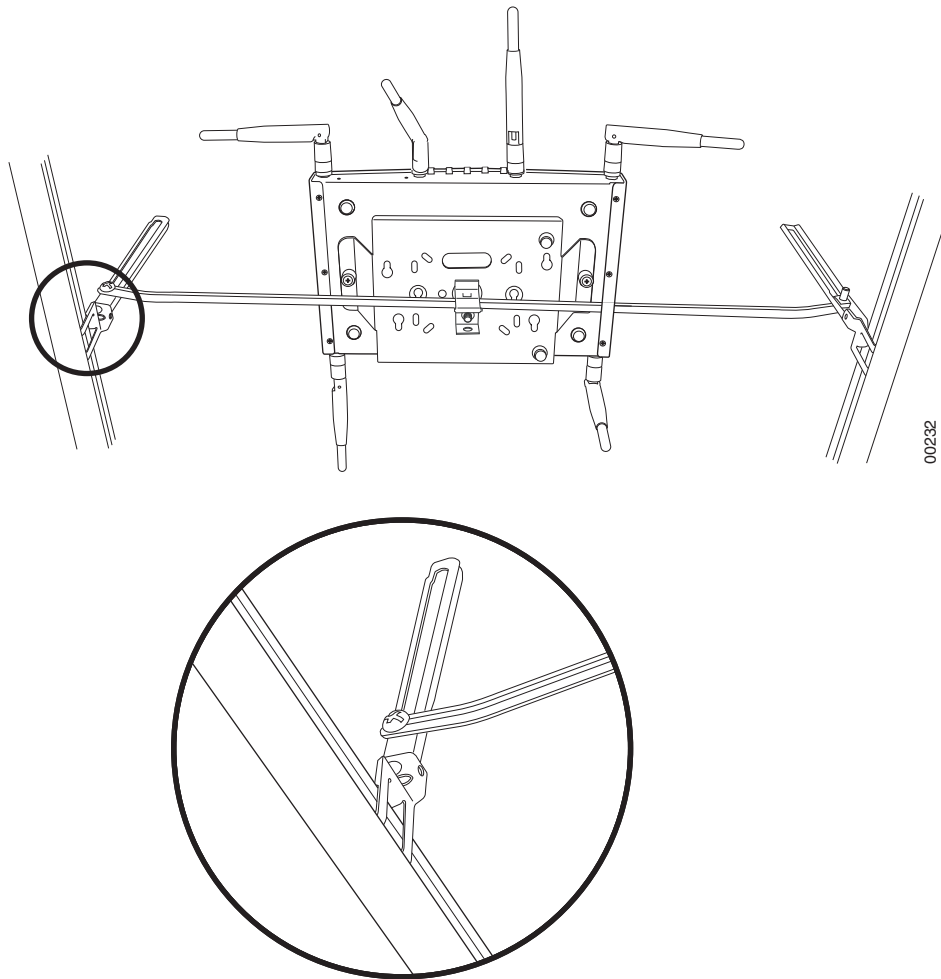

The AP300 with the metal enclosure exposed meets the requirements for fire resistance and low smoke-generating characteristics required by Section 300-22(C) of the National Electrical Code (NEC) for installation in a building's environmental air space.

You may need to modify thicker tiles to support this installation.



**Warning!** When installed in air-handling spaces, such as above a suspended ceiling, power the AP300 only with a PoE, not a power supply. See [Power Supplies](#) for part numbers.



**Warning!** Any Fast Ethernet (FE) cables installed in air-handling spaces should be suitable under NEC Article 800.50 and marked accordingly for use in plenums and air-handling spaces with regard to smoke propagation, such as CL2-P, CL3-P, MPP (Multi Purpose Plenum), or CMP (Communications Plenum). Use Ethernet cable that meets the requirements for operating in plenums and environmental air space in accordance with Section 300-22(C) of the NEC.

## Install the AP300

To mount an AP300 above the ceiling with the optional T-bar kit, follow these steps:

1. Determine the location on the ceiling rails where the AP will be mounted and remove the ceiling tile.
2. Unpack the T-bar hanger kit and unfold the legs of the T-bar hanger.
3. Locate the bracket mounting clipholes on the mounting bracket (see [Figure 10](#)). One hole attaches the bracket perpendicular to the box hanger; the other mounts the bracket parallel to the box hanger.
4. Attach the U-joint of the clip to the T-bar and snap in place (see [Figure 12](#)).

Figure 12: Attaching the Mounting Bracket to the Box Hanger for Face Up Orientation

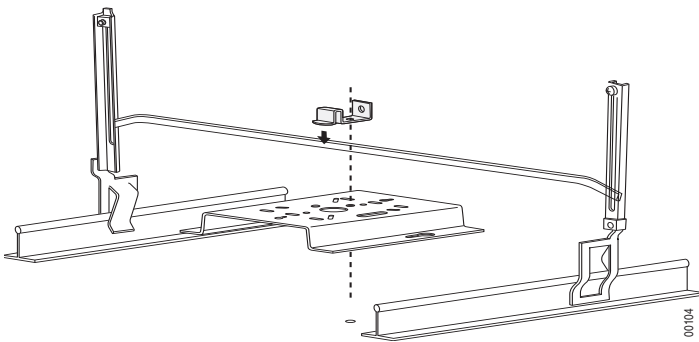
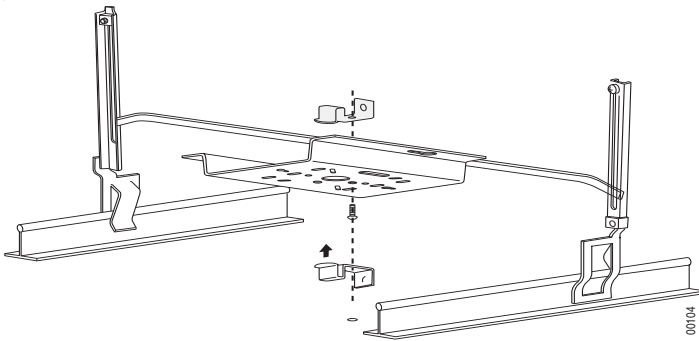

Figure 13: Attaching the Mounting Bracket to the Box Hanger for Face Down Orientation



5. Pass the long end clip through the large center hole to the underside of the mounting bracket clip and then attach the bracket to the clip using the supplied screw (see [Figure 12](#) for orientation).

6. Hold the AP300 next to the mounting bracket to estimate the height of the T-bar box hanger. You need to provide enough clearance for the external antennas that point down, while mounting the T-bar on the lower half of the support rails for stability.
7. Adjust the height of the box hanger using the height adjusting screws (see [Figure 9](#)).
8. Clip the box hanger T-rail clips to the ceiling rails, making sure they are securely attached.
9. Connect a drop wire to a building structural element and through the hole provided in the bracket mounting clip. The U.S. National Electrical Safety Code requires this additional support.
10. Connect the posts of the AP300 to the three keyholes of the mounting bracket and slide into the keyhole, ensuring the locking detent is engaged. You will hear a click.
11. For each antenna, loosen the knurled ring at the base of the antenna, point the antenna down, then retighten the ring.
12. Connect one end of the PoE Ethernet cable to the Ethernet connector.



**Caution!** Be sure to connect the Ethernet cable to the Ethernet port; the cable can mistakenly be plugged into the Console port. If you do this, the AP won't power up.



**Note:** Use a shielded Cat 5e (or greater) Ethernet cable in order to comply with international electromagnetic emissions limits.

13. Check that the AP300 is operating correctly before replacing the ceiling tile to the ceiling. Verify correct operating using the LEDs, as shown in [Check AP300 LED Activity](#).

## Mount AP300 in a Hoffman Enclosure

Meru has designed a custom mounting bracket compatible with a Hoffman enclosure ([www.hoffmanonline.com](http://www.hoffmanonline.com)). This bracket is available exclusively through Meru and orderable as part number ACC-AP300-BHE. To mount an AP300 in a Hoffman enclosure, follow these steps:

1. Place AP300 upside down on a soft flat surface.
2. Remove and discard the wall/ceiling mounting bracket.
3. Attach either the provided antennas or an external antenna.
4. Remove and discard the four rubber feet.
5. Position the Hoffman bracket (ACC-AP300-BHE) onto the back of the AP300 with the four Hoffman mounting screws facing downwards.

Figure 14: Hoffman Bracket ACC-AP300-BHE

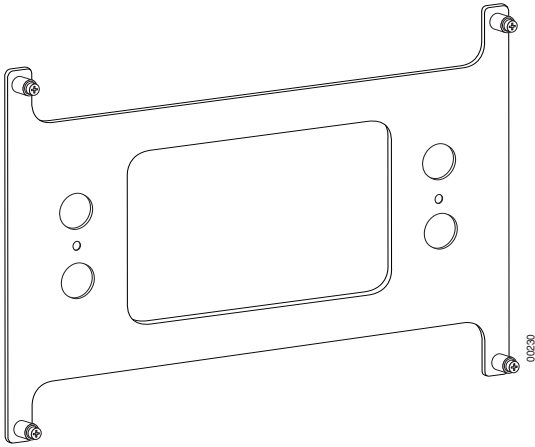

6. Using a Phillips screw driver, attach the bracket using the two supplied 6-32 3/16 SEMS screws.
7. Flip the assembly over and mount into the Hoffman enclosure, attach the Ethernet cable to the AP300 rotating the assembly to place the Ethernet cable within the enclosure.
8. Using a Phillips screw driver, tighten the four bracket screws to the enclosure.
9. Adjust the antennas as needed.

## Check AP300 LED Activity

---

When AP300 first connects to the controller (and any time the access point is rebooted), the AP initializes and is then programmed by the controller. When the AP first powers up, all LEDs are green.

Figure 15: AP300 Status LEDs

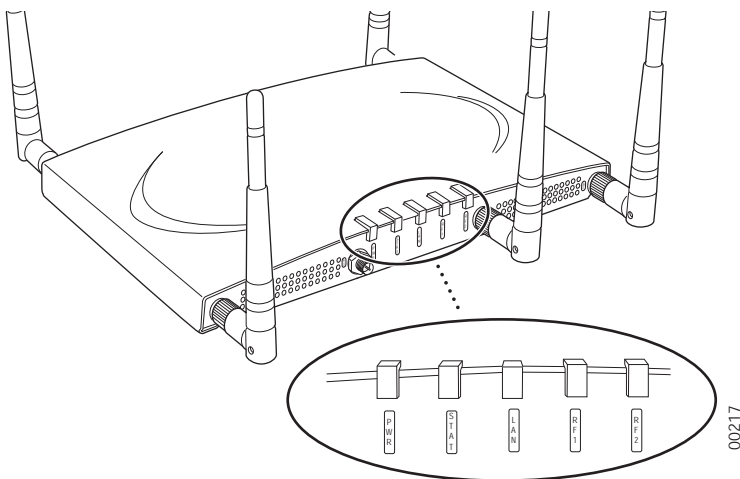

After the AP300 is connected, check the status of the LEDs. The functions of the five LEDs are described below.



## AP300/AP300i LED Descriptions

LED	Function	Troubleshooting
Power	<p>off—no power</p> <p>green—presence of power</p>	
Status	<p>off—no power</p> <p>green—booting stage 1</p> <p>blinking green and off—booting stage 2</p> <p>blinking green and white—discovering the controller</p> <p>blinking green and blue—downloading a configuration from the controller</p> <p>blinking blue and off—AP is online and enabled, working state</p> <p>blinking red and yellow—failure; consult controller for alarm state</p>	<p>If the status LED is blinking red and yellow, there is an alarm on the AP. Determine what the alarm is by clicking <b>Monitor &gt; Dashboard &gt; Alarms</b> and looking at the AP alarms. You can also use the CLI commands <code>show alarm</code> and <code>show log</code>.</p>
LAN	<p>off—no power or no link</p> <p>green—link status OK (at any speed)</p> <p>green/blinking—activity (at any speed)</p> <p>red—auto negotiation failure</p>	<p>If the LAN LED is red, auto negotiation failed. This means that you have a problem with cabling or with the AP's switch.</p>
Radio 1 Radio 2	<p>off—no radio present</p> <p>green—radio enabled</p> <p>green blinking—data activity</p> <p>yellow—disabled or in scanning mode</p> <p>red—failure</p>	<p>If one of the radio LEDs is yellow, it is either disabled or in scanning mode. To see if the AP is disabled, click <b>Configuration &gt; Wireless &gt; Radio &gt; select a radio</b> and then look at <b>Administrative Status</b>, which should be set to <b>Up</b>. To see if the AP is in <b>Scanning Mode</b>, click <b>Configuration &gt; Wireless &gt; Radio &gt; select a radio</b> and look at <b>AP Modes</b>, which should be set to <b>Normal Mode</b>.</p> <p>If one of the radio LEDs is red, the radio failed. Check the alarms (<b>Monitor &gt; Dashboard &gt; Alarms</b>), diagnostics (<b>Monitor &gt; Diagnostics &gt; Radio</b>), and statistics (<b>Monitor &gt; Dashboard &gt; Radio</b>) on the AP's controller to determine the cause.</p>

## Where to Go From Here

---

Now that the AP300 is installed, refer to the *Meru System Director Getting Started Guide* for instructions on initializing the hardware. Return to this chapter to check the status of the LEDs once the WLAN is operational.

# Chapter 3

## Installing AP320i

AP320i is supported by System Director versions 3.6.1 and greater, but full support begins with System Director release 4.0. Because of this, when using AP320i with System Director 3.6.1, the unit shows as an AP300, for example AP320 instead of AP320i. All AP320i units still function correctly, they just display as AP300 because AP320i did not exist when System Director 3.6.1 was released.

This chapter describes how to install and configure an AP320i. It contains the following sections:

- [Safety Precautions](#)
- [Unpack the AP320i](#)
- [Determine Power Requirements](#)
- [Installation Requirements](#)
- [Installing AP320i](#)
- [Check AP320i LED Activity](#)
- [Where to Go From Here](#)

## Safety Precautions

---

**IMPORTANT**—Read and follow the regulatory instructions in Appendix B before installing and operating this product.

If an optional power supply is used, it must be one supplied by Meru Networks.

The AP320i is only intended for installation in Environment A as defined in IEEE 802.3af. All interconnected equipment must be contained within the same building, including the interconnected equipment's associated LAN connection.

# Best Practices for an AP320i/AP200 Network

---

Read this section if you have both AP200 and AP320i active simultaneously on the same network. The following best practices should be followed to get optimal performance from such a mixed network.

- Do not deploy AP200 and AP300/AP320i at the same physical location; we recommend that there be no overlapping coverage between AP200 and AP300.
- If AP200 and AP300/AP320i do have overlapping coverage, make sure the ESS profiles on both AP types are unique. The chart below shows two scenarios, one supported, one not supported.
- AP320i and AP300 are interchangeable and fully compatible to share a virtual cell. It's like having two AP300s with different antennas. The only difference is that AP320i is detected as a such in the UI of the controller.

Supported Scenario	AP200 Configuration	AP320i Configuration
Two Unique ESS profiles	ESS Profile name in controller is UniqueName1	ESS Profile name in controller is UniqueName2
AP200 and AP320i SSID string over the air	Meru	Meru

Unsupported Scenario	AP200 Configuration	AP320i Configuration
Same ESS profiles	ESS Profile name in controller is same name	ESS Profile name in controller is same name
AP200 and AP320i SSID string over the air	Meru	Meru

Assumptions for the above best practices include:

- AP200 is using Virtual Port with BSSID Virtual Cell (AP200 could also be using Shared BSSID Virtual Cell.)
- AP320i is using Virtual Port with BSSID Virtual Cell.
- AP200s and AP300s are on the same channel. (AP200 and AP320i could also be on different channels.)
- AP200s and AP320i is are on the same controller. (AP200 and AP320i could also be on different controllers as long as each controller has a unique controller index.)

# Unpack the AP320i

---

Confirm that the shipping box contains the following:

- AP320i with an attached ceiling mounting bracket
- Wall mount bracket with screws
- Small locking key for ceiling or wall mount locking

## Determine Power Requirements

---

Power requirements vary, depending on which AP300 radios are deployed and what MIMO mode is used. See the chart below for supported power sources for different radio configurations.

Radio 1 MIMO	Radio 2 MIMO	802.3af PoE	802.3at PoE	DC Power
2x2	2x2	●	●	●
2x2	3x3	●	●	●
3x3	2x2	●	●	●
3x3	3x3	Do not recommend	Recommend with caution	●

### 802.af PoE Usage

When using System Director 3.6/4.0 and 802.3af PoE, Meru supports radios set to any MIMO settings except 3x3 on dual radios. This is because two radios set to 3x3 MIMO using an 802.3af switch may not have enough power if the cable is too long. Shorter cables frequently work, however. Meru supports:

- Single 3x3 radio
- Dual 2 x 2 radios
- Dual radio with one set to 2x2 and the other one set to 3x3

When using System Director 4.0 and 802.3af, the AP300 MIMO configuration is limited to the following:

- 3x3 for the 5 GHz radio
- 2x2 for the 2.4 GHz radio

## 802.3at Usage

When using System Director 3.6/4.0 and 802.3at, the following radio combinations are recommended:

- Single 3x3 radio
- Dual 2 x 2 radios
- Dual radio with one set to 2x2 and the other one set to 3x3
- Dual 3x3 radios are recommended with a limitation. Use 802.3at power for two 3x3 MIMO radios when the switch has a high enough power output to support all devices on the PoE. Calculate the amount of power needed by each AP300/AP320i in 3x3 mode (13 watts), add that to power required by other PoE devices on the switch and compare that value to the total power output from the switch. The calculation for 802.3at PoE use looks something like this:

`(Number of AP300s * 13watts) + (sum of all other PoE devices power requirements) <= switch power provided`

# Installation Requirements

---

Installation Type	Order These Additional Items
Horizontal mounting	None
Vertical mounting over a wall stud	None
Vertical mounting on sheetrock	None
Horizontal mounting below a hanging ceiling	None
Reusing an existing bracket from another AP	For connection to Meru AP200 or AP150 only, order shoulder screws, Meru part number 665-00012 (SCR, PIC. 1/4*1/8 10-32 SKT SHLDR SCR 303 STNLS). Connection to other brackets does not require this.

## Additional Equipment

A power source is needed to power the AP300. See [Determine Power Requirements](#). If you want to lock an AP320i to the ceiling or wall, you need a small key like the ones used to lock suitcases.

# Installing AP320i

---

## Select a Location

All AP320i interconnected equipment must be contained within the same building, including the interconnected equipment's associated LAN connection. Ceiling mounting is recommended but wall mounting is also supported. In addition, the AP320i should be mounted in a location that meets the following conditions:

- Relatively unobstructed access to the stations the AP serves. Select a location with minimal physical obstructions between the AP and the wireless stations. In an office with cubicles, mounting the APs below a hanging ceiling (plenum is supported) or the wall near the ceiling provides the least obstructed communications path. On a wall, orient the AP320i horizontally so that you can read the Meru logo without tilting your head at 90 degrees - this orientation provides optimum MIMO performance.
- Access to wall outlet or a Power over Ethernet (PoE) connection to the network switch servicing the controller.

AP320i is designed to provide 180 degree omni-directional coverage as illustrated below. Plan placement with this pattern in mind.

Figure 16: Coverage Pattern for AP320i When Ceiling Mounted



Most installations receive the best coverage using the following guidelines:

- Install APs toward the center of the building.
- Place APs about 80 feet apart.
- Do not install APs near metal objects, such as heating ducts, metal doors, or electric service panels.
- If you install AP320i on a pole, keep in mind that coverage will be 180 degrees. Do not mount two AP320is back to back on a pole to achieve 360 degree coverage, however, because the two units could interfere with each other.

## Install the Access Point

- ✓ The AP320i ships with a detachable ceiling mounting bracket, making the unit ready for ceiling mounting. You can also remove the ceiling-mount bracket and use the included wall-mount bracket. The wall mount bracket can be attached to sheetrock, wall studs, or another wall bracket supplied by Meru and by other vendors. If you are replacing AP200s/AP300 wall brackets, the AP320i bracket can be mounted on top of the old AP200/AP300 bracket using shoulder screws (not included); you don't need to remove the old brackets. AP320i can also be directly mounted on standard third-party wall

## Installing AP320i

brackets such as the Proxim AP4000 bracket and standard Cisco brackets. You cannot, however, mount AP320i directly on an AP150 wall-mount bracket; in this case, you must remove and replace the AP150 bracket. Installation directions are provided below.

Mount AP320i in any of the following ways:

- [Mount AP320i On a Suspended Ceiling](#)
- [Mount AP320i Above a Suspended Ceiling \(Plenum\)](#)
- [Mount AP320i Vertically on a Wall](#)
- [Set AP320i on a Shelf](#)
- [Mount AP320i Below a Recessed Ceiling](#)



## Mount AP320i On a Suspended Ceiling

AP320i ships ready to mount on a suspended ceiling; the attached bracket clips to a ceiling rail.

To mount an AP320i below a suspended ceiling, follow these steps:

1. Determine the location on the ceiling rail where the AP will be mounted and remove the ceiling tiles.
2. Align the mounting bracket with the slots indicated in [Figure 17](#) below.

Figure 17: Install AP320i Below a Suspended Ceiling

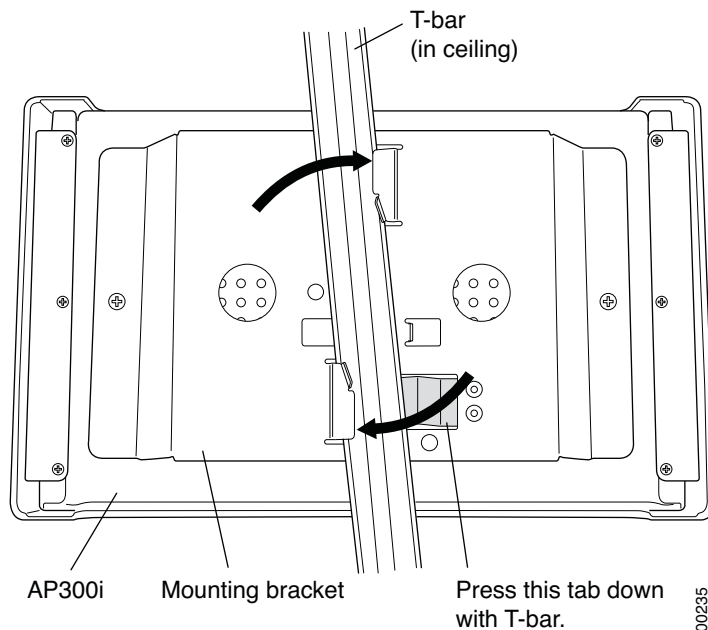

3. Press down on the tab indicated in [Figure 17](#) and rotate the AP320i into place.
4. Connect one end of the CAT5 (or greater) Ethernet cable to the 100/1000 Ethernet connector.



**Caution!** Be sure to connect the Ethernet cable to the Ethernet port. The cable can mistakenly be plugged into the Console port; if you do this, the AP won't power up.

Figure 18: AP320i Ethernet Port on the Right

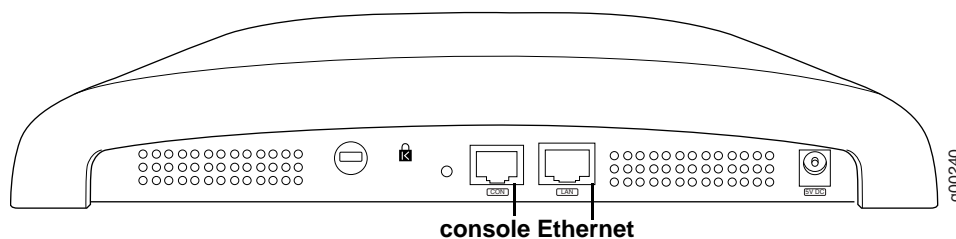

5. Optionally install a small lock (not supplied) to secure the AP320i to the ceiling rail. See [Figure 19](#). To do this, you need the security key that shipped with the AP320i.

Figure 19: Optionally Install Your Own Lock on AP320i

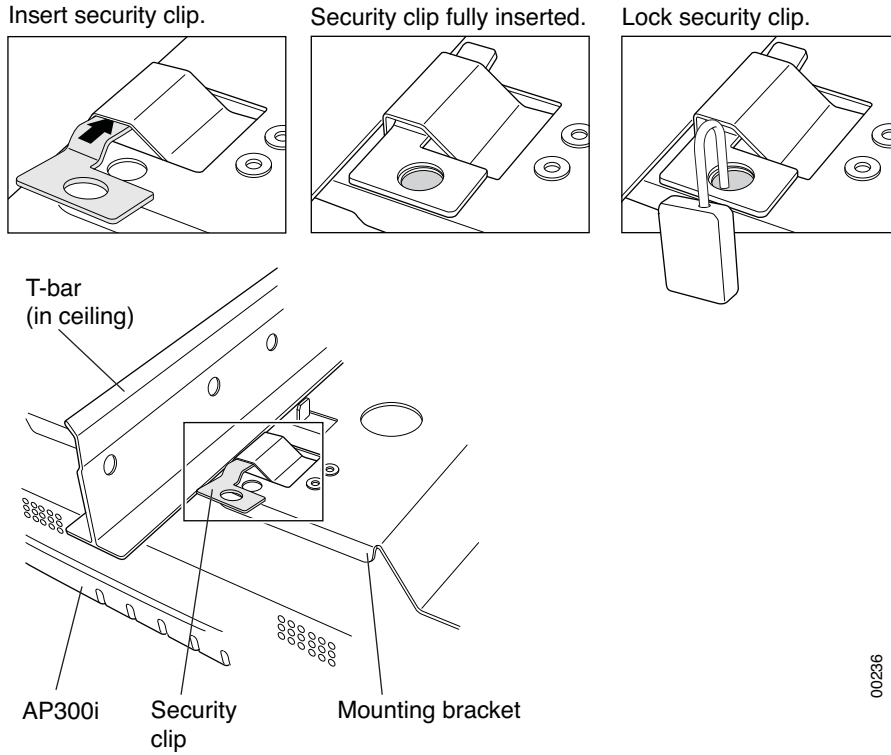

### Mount AP320i Above a Suspended Ceiling (Plenum)

AP320i is not plenum rated.

## Mount AP320i Vertically on a Wall

The AP320i ships with a ceiling mount bracket already connected to the unit and an additional separate wall bracket. When wall mounting a unit, you will attach the wall mount bracket to the wall, then attach the ceiling bracket (including AP320i) to the wall bracket. If you are replacing an AP200 or AP150, the AP320i wall bracket can be mounted on top of the old bracket using shoulder screws (not included - see [Installation Requirements](#)); you don't need to remove the old brackets. If you are replacing an AP300 or third-party brackets such as the Proxim AP4000 bracket and standard Cisco brackets, the AP320i wall bracket can also be mounted on top of the old bracket (no additional screws required).

To mount an AP320i on sheetrock or wall studs, follow these steps:

1. Using the wall bracket holes as a guide, mark the location on the wall for two AP bracket mounting screws. Orient the connected AP300 horizontally so that you can read the Meru logo without tilting your head at 90 degrees - this orientation provides optimum MIMO performance.

Figure 20: AP320i Wall Bracket

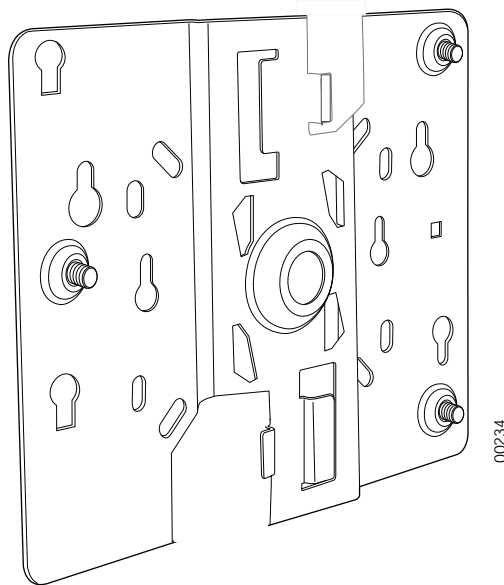

If possible, center the mounting screws on a wall stud. If you do not center the mounting screws on a wall stud, use plastic wall anchors.

2. Drill holes at the locations you marked:
  - 3/16-inch holes if you are using plastic anchors
  - 1/8-inch holes if you are using only the screws
3. If you are using plastic anchors, install them in the holes.
4. Screw in the screws most of the way.
5. Mount the bracket on the screws, placing the circular portion of the keyhole mounts over the screw heads and sliding the bracket down.

6. Connect one end of the Ethernet cable to the switch and the other end to the AP320i Ethernet port.

**!** **Caution!** Be sure to connect the Ethernet cable to the Ethernet port. The cable can mistakenly be plugged into the Console port; if you do this, the AP won't power up.

Figure 21: AP320i Ethernet Port on the Right

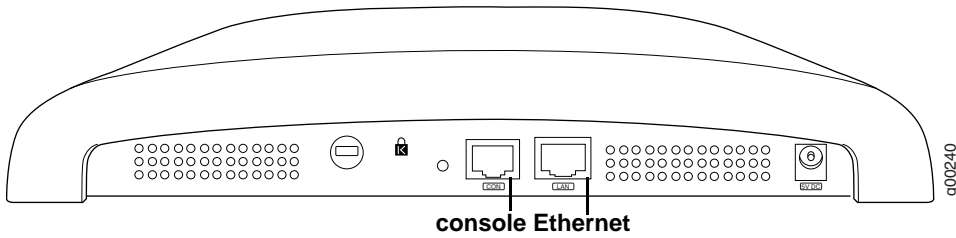

7. If you are not using a PoE device, connect an external power supply to the power connector and plug it into the wall.
8. Align the tabs on the wall bracket with the tabs on the ceiling bracket and then rotate the AP320i clockwise to secure it to the wall. See [Figure 22](#) below.

Figure 22: Mount AP320i on a Wall

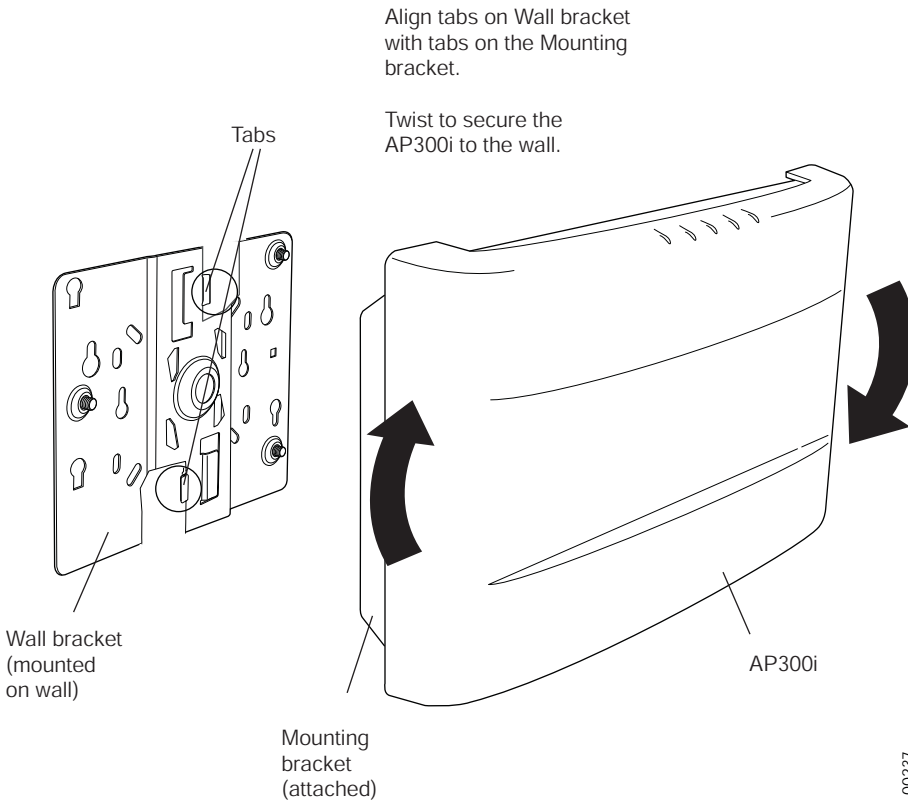
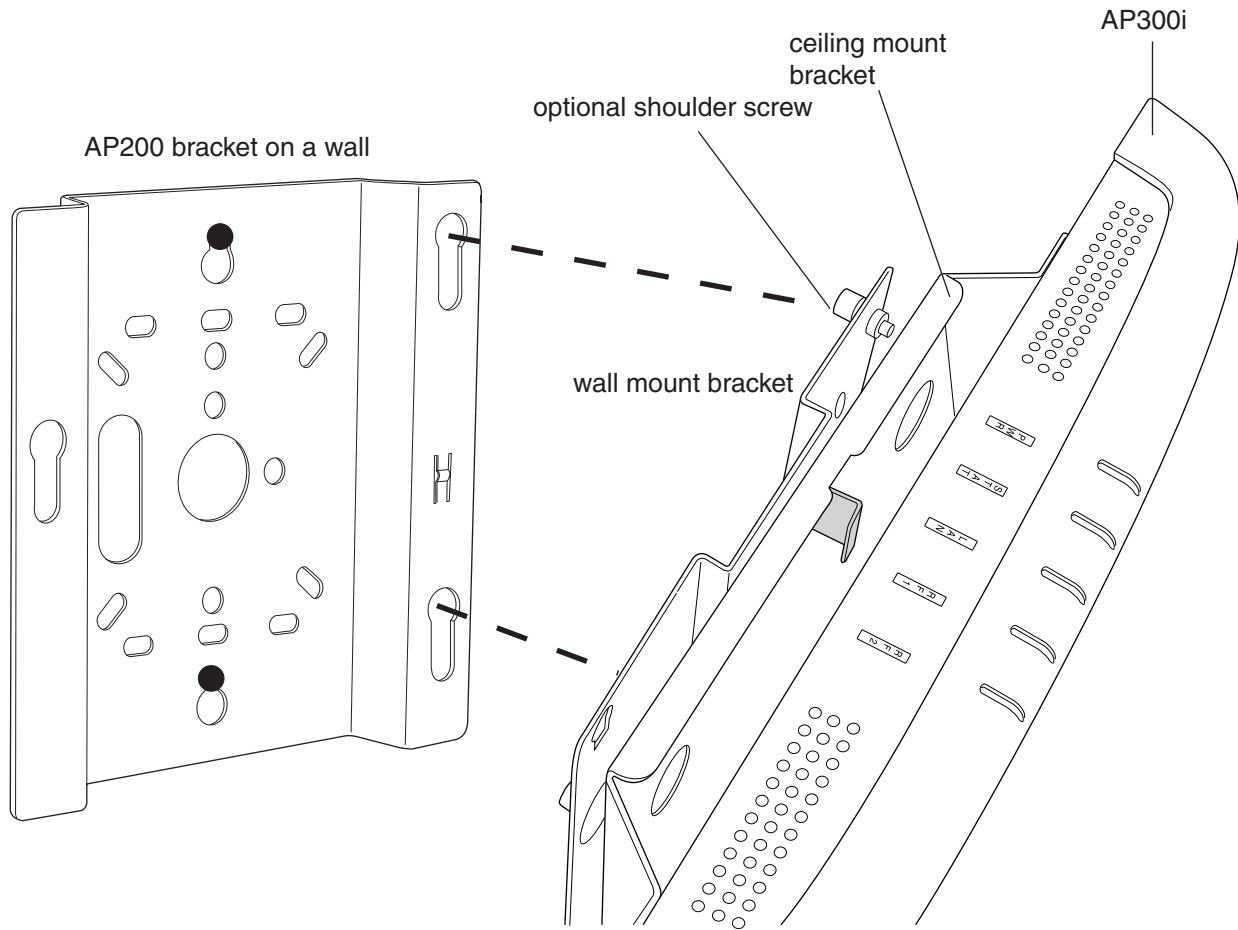
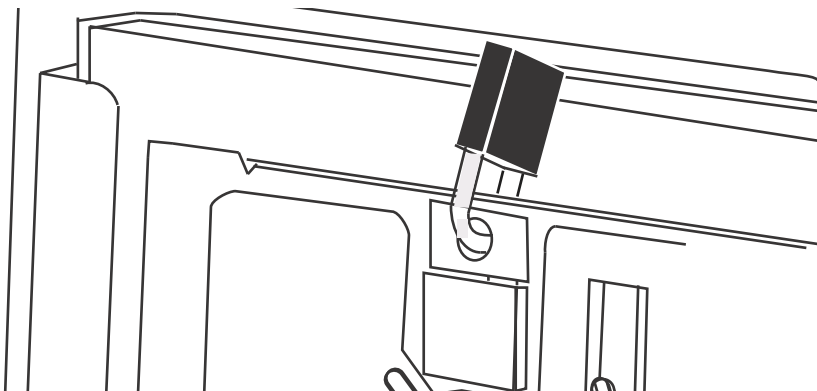

Figure 23: Mount AP320i on an AP200 Wall Bracket



9. Optionally, lock the AP320i bracket by inserting the provided locking key and applying a small lock.

Figure 24: AP320i Locked to a Wall



## Set AP320i on a Shelf

You can remove the mounting bracket(s) before setting AP320i on a shelf - see [Figure 25](#).

Figure 25: Remove the AP320i Ceiling Mount Bracket

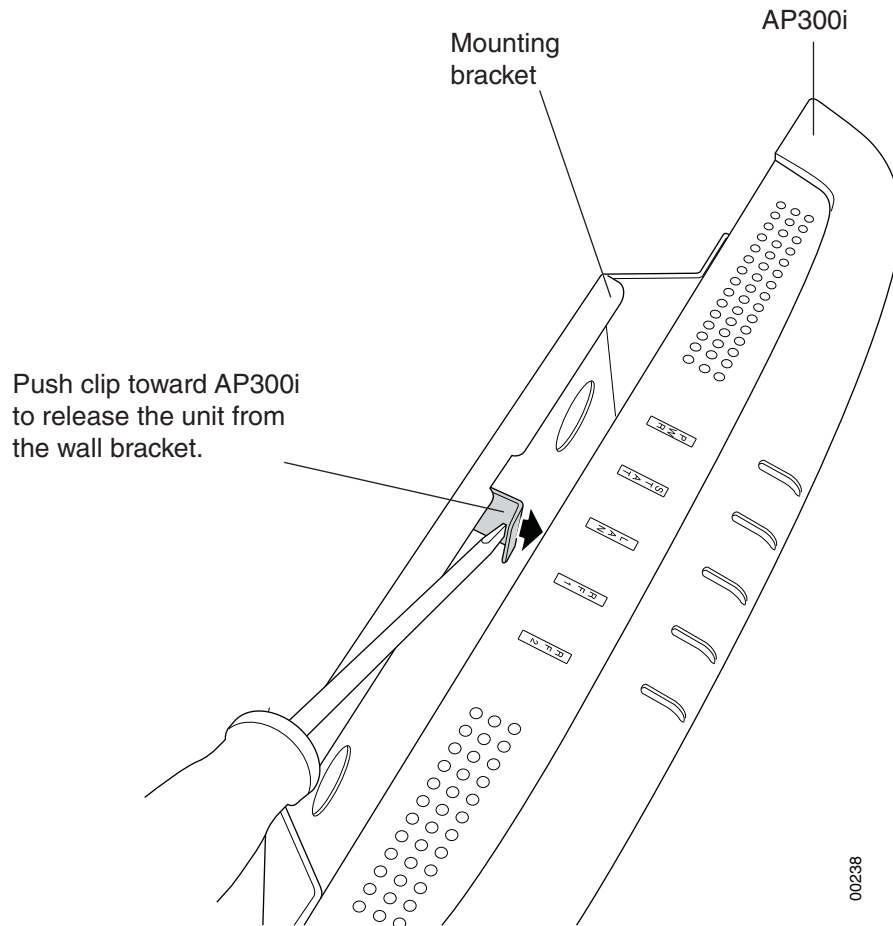

## Mount AP320i Below a Recessed Ceiling

RECESSED CEILING MOUNT KIT???

## Check AP320i LED Activity

---

When AP320i first connects to the controller (and any time the accesspoint is rebooted), the AP initializes and then is programmed by the controller. When the AP first powers up, all LEDs are green. Thereafter, the Status LED color reflects the various operating states.

Figure 26: AP320i Status LEDs

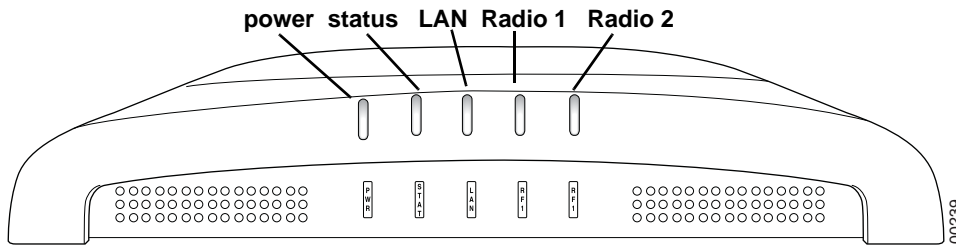

After the AP320i is connected, check the status of the LEDs. The functions of the five LEDs are described below.

AP300/AP320i LED Descriptions

LED	Function	Troubleshooting
Power	off—no power green—presence of power	
Status	off—no power green—booting stage 1 blinking green and off—booting stage 2 blinking green and white—discovering the controller blinking green and blue—downloading a configuration from the controller blinking blue and off—AP is online and enabled, working state blinking red and yellow—failure; consult controller for alarm state	If the status LED is blinking red and yellow, there is an alarm on the AP. Determine what the alarm is by clicking Monitor > Dashboard > Alarms and looking at the AP alarms. You can also use the CLI commands show alarm and show log.
LAN	off—no power or no link green—link status OK (at any speed) green/blinking—activity (at any speed) red—auto negotiation failure	If the LAN LED is red, auto negotiation failed. This means that you have a problem with cabling or with the AP’s switch.
Radio 1 Radio 2	off—no radio present green—radio enabled green blinking—data activity yellow—disabled or in scanning mode red—failure	If one of the radio LEDs is yellow, it is either disabled or in scanning mode. To see if the AP is disabled, click Configuration > Wireless > Radio > select a radio and then look at Administrative Status, which should be set to Up. To see if the AP is in Scanning Mode, click Configuration > Wireless > Radio > select a radio and look at AP Modes, which should be set to Normal Mode.  If one of the radio LEDs is red, the radio failed. Check the alarms (Monitor > Dashboard > Alarms), diagnostics (Monitor > Diagnostics > Radio), and statistics (Monitor > Dashboard > Radio) on the AP’s controller to determine the cause.



# Where to Go From Here

---

Now that the AP320i is installed, go to the *Meru System Director Getting Started Guide* for instructions on initializing the hardware. Return to this chapter to check the status of the LEDs once the WLAN is operational.

Where to Go From Here

# Chapter 4

## Installing AP200

This chapter describes how to physically install an AP200. It contains the following sections:

- [Safety Precautions](#)
- [Unpacking the AP200](#)
- [Installation Requirements](#)
- [Installing the Access Points](#)
- [Where to Go From Here](#)
- [Checking LED Activity](#)

## Safety Precautions

---

**IMPORTANT**—Read and follow the instructions in “Regulatory Information” on page 109 before installing and operating this product.

## Unpacking the AP200

---

As you unpack the AP200, confirm that the AP200 shipping package contains the items listed on your packing list.

Shipments of the AP200 include a mounting bracket and mounting hardware for standard wall mounting. Optional mounting kits are available for mounting the AP200 above or below a hanging ceiling. The AP200 mounting studs are placed so they can be used with brackets supplied by other vendors or to replace an AP100.

-  **Note:** The AP200 has a security cable slot so you can secure the AP200 with a standard security cable, such as those used to secure laptop computers.

An array of holes on the mounting bracket (see [Figure 15](#)) allows it to be mounted on the wall and over junction boxes or molly bolts. There are also holes for passing the PoE Ethernet or external power supply cable through the bracket if the bracket is mounted on a junction box or over the ceiling T-bar box hanger.

Figure 15: AP200 Mounting Bracket

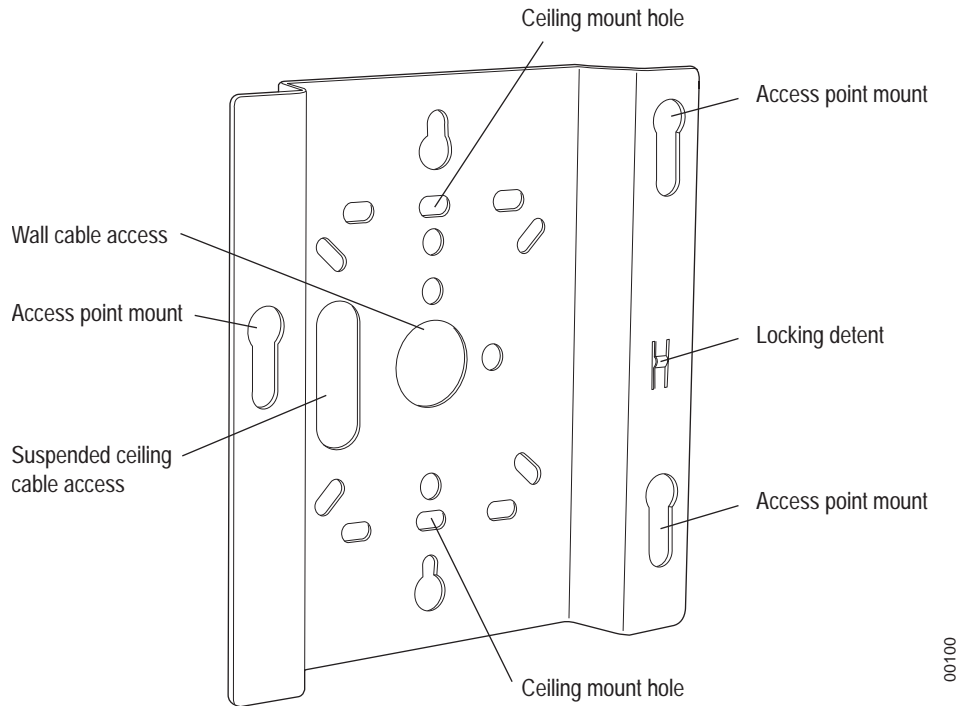

## Installation Requirements

---

The following recommended mounting locations provide the best reception for the AP200:

- On a horizontal surface, such as a table or a desk
- On a vertical surface, usually a wall
- Below a hanging ceiling
- Above a hanging ceiling tiles (this installation is supported only for the AP200 with the plastic enclosure removed)



**Warning!** With plastic covers removed, this product is suitable for use in environmental air space in accordance with the Section 300-22(c) of the National Electric Code and Sections 2- 128.12 - 010 (3) and 12 - 100 of the Canadian Electrical Code. Part 1. C22. 1. For other countries, consult local authorities for regulations.

To complete this installation, you need the items listed below.

Installation Type	Consumable Items Required
Horizontal mounting	None
Vertical mounting over a wall stud	<ul style="list-style-type: none"> <li>● Two #6 x 2" wood screws for a wood stud; or</li> <li>● Two #6 x 1½" metal screws for a metal stud</li> <li>● Mounting bracket</li> </ul>
Vertical mounting on sheetrock	<ul style="list-style-type: none"> <li>● Two #6 x 1" screws</li> <li>● Two #4-6 x 7/8" ribbed plastic wall anchors</li> <li>● Mounting bracket</li> </ul>
Horizontal mounting below a hanging ceiling	<ul style="list-style-type: none"> <li>● Two caddy fasteners</li> <li>● Two plastic spacers</li> <li>● Two keps nuts (with a ttached lock washer)</li> <li>● Mounting bracket</li> </ul>
Mounting above a ceiling tile (AP200 metal enclosure only)	<ul style="list-style-type: none"> <li>● Two T-rail clips</li> <li>● One T-box hanger</li> <li>● One bracket mounting clip</li> <li>● Mounting bracket</li> </ul>

You need the tools listed below.

### AP200 Installation Tools

Installation Type	Tools Required
Horizontal mounting	None
Vertical mounting over a wall stud	<ul style="list-style-type: none"><li>• Drill</li><li>• 1/8" drill bit</li><li>• Screwdriver</li></ul>
Vertical mounting on sheetrock	<ul style="list-style-type: none"><li>• Drill</li><li>• 3/16" drill bit</li><li>• Screwdriver</li></ul>
Horizontal mounting below a hanging ceiling	<ul style="list-style-type: none"><li>• Screwdriver</li><li>• Wrench or pliers</li></ul>
Mounting above a hanging ceiling (AP200 metal enclosure only)	<ul style="list-style-type: none"><li>• Wrench or pliers</li><li>• Screwdriver</li></ul>

# Installing the Access Points

---

## Selecting a Location

The AP200 requires a location that meets the following:

- Relatively unobstructed access to the stations the AP serves
- Power over Ethernet (PoE) connection to the network switch servicing the controller.

APs can obtain their power from 802.3af standard Power over Ethernet (PoE)-compatible network switch or PoE power injector installed between the switch and the AP200.

Select a location with minimal physical obstructions between the AP and the wireless stations. In an office with cubicles, mounting the APs below a hanging ceiling or the wall near the ceiling provides the least obstructed communications path. For an external power supply connection, ensure the power source is near to where the AP200 will be mounted.

Most installations receive the best coverage using the following guidelines:

Install APs toward the center of the building.

- Do not install APs near metal objects, such as heating ducts, metal doors, or electric service panels.
- Relative to the ground, orient the antenna up or down, not sideways.



**Note:** The previous guidelines are general guidelines. Each site has its own unique environment. Place access points accordingly.

The AP200 is only intended for installation in Environment A as defined in IEEE 802.3af. All interconnected equipment must be contained within the same building, including the interconnected equipment's associated LAN connection.

## Attaching the AP200 Antennas

The AP200 is provided with external antenna ports. Make sure that all external antennas and their associated wiring are located entirely indoors. The external antennas are not suitable for outside use.

If the AP200 does not have external antennas, attach the antennas to the connectors on the AP200 (see [Figure 16](#)). Rotate the knurled ring at the base of the antenna clockwise to attach the antenna. The ring should be finger-tight.



**Caution!** When changing the orientation of the antennas, be sure to slightly loosen the knurled ring before moving the antenna. Retighten the ring afterward. Otherwise, you might damage the internal cabling in the AP.

## Mounting the Access Point

You can mount an AP200 in the following ways:

- Horizontally, as described in the “Horizontal Mounting” section.
- Vertically, as described in the “Vertical Mounting” section.
- Below a hanging ceiling, as described in the “Mounting Below a Suspended Ceiling” section.
- Above a tiled hanging ceiling, as described in the “Mounting Above a Suspended Ceiling” section.

### Horizontal Mounting

To horizontally mount an AP200:

1. Place the AP200 flat on the horizontal surface.
2. For each antenna, loosen the knurled ring at the base of the antenna (see [Figure 16](#)), point the antenna straight up, then retighten the ring.

Figure 16: AP200 Antenna Connection

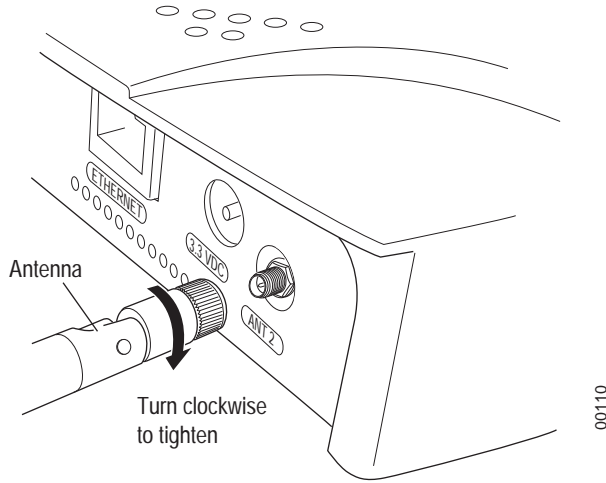

3. Connect one end of the PoE 100BaseT Ethernet cable to the 100/1000 Ethernet connector, shown in [Figure 17](#).



**Note:** For the AP201 and AP208 access points, a shielded Cat 5e (or greater) Ethernet cable must be used in order to comply with international electromagnetic emissions limits.

If it is not practical to use shielded cables, contact Support for a line filter, available at no charge, that may also be used to ensure compliance.



**Caution!** Be sure to connect the Ethernet cable to the Ethernet port; the cable can mistakenly be plugged into the Console port (see [Figure 17](#)).

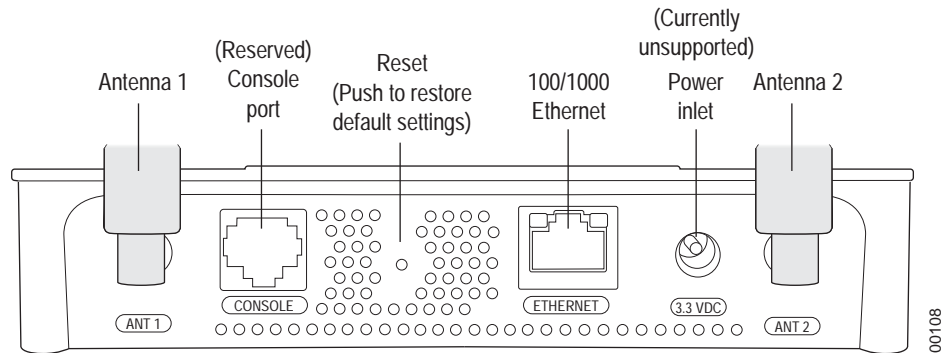
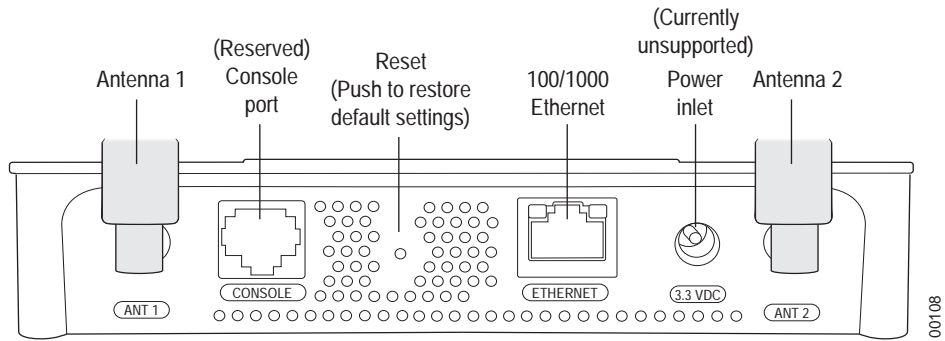



Figure 17: AP200 Connector Panel



## Vertical Mounting

To vertically mount an AP:

1. Using the bracket holes as a template, mark the location on the wall for the two AP bracket mounting screws. They are placed 4 ½ inches apart, center-to-center, one above the other. If you are not using plastic wall anchors, you must center the mounting screws on a wall stud. If you do not center the mounting screws on a wall stud, you must use plastic wall anchors.

Figure 18: AP200 Bracket

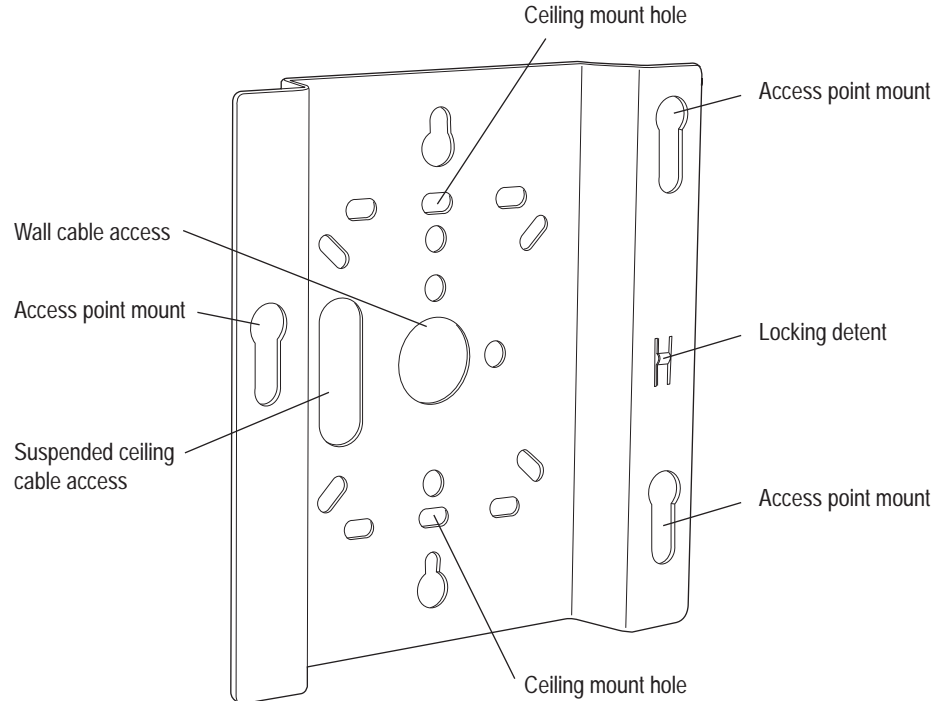

## Installing the Access Points

2. Drill holes at the locations you marked:
  - 3/16-inch holes if you are using plastic anchors
  - 1/8-inch holes if you are using only the screws
3. If you are using plastic anchors, install them in the holes.
4. Screw in the screws most of the way, so that the screw head is about 1/16 of an inch from the wall.
5. Mount the bracket on the screws, placing the circular portion of the keyhole mounts over the screw heads and sliding the bracket down.
6. Tighten the screws to secure the bracket.
7. Align the AP200 mounting posts over the circular portion of the keyhole mounts, push the AP in and slide the AP down until it engages with the locking detents. You should hear it snap in place.

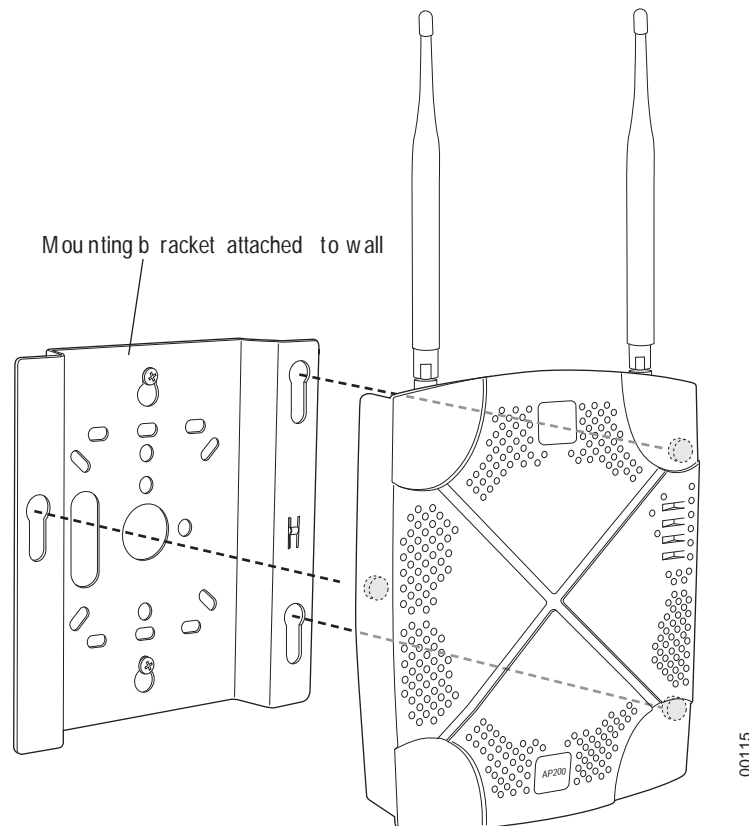

Figure 19: Aligning the AP200 with the Bracket

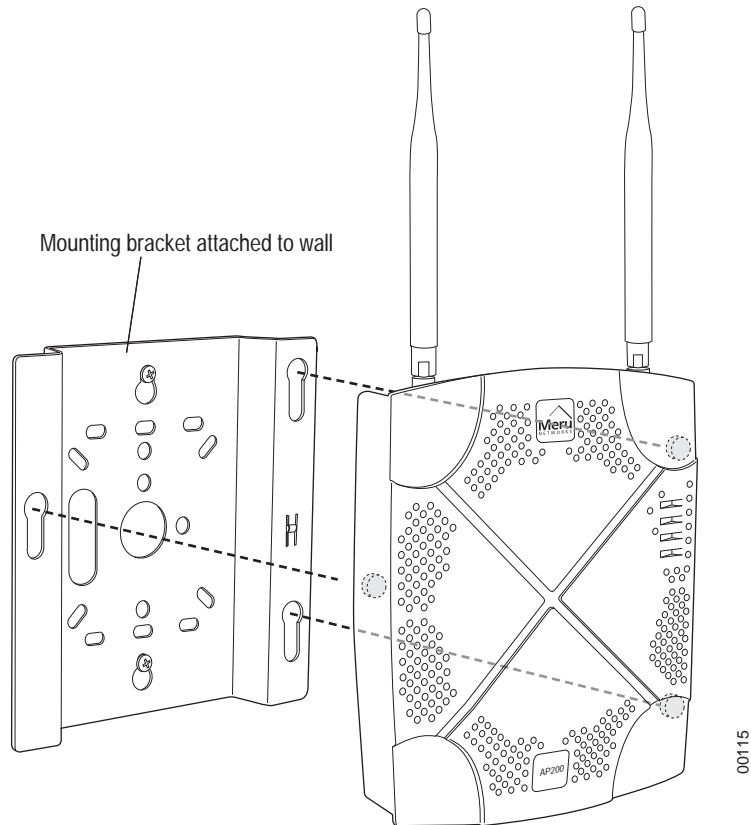
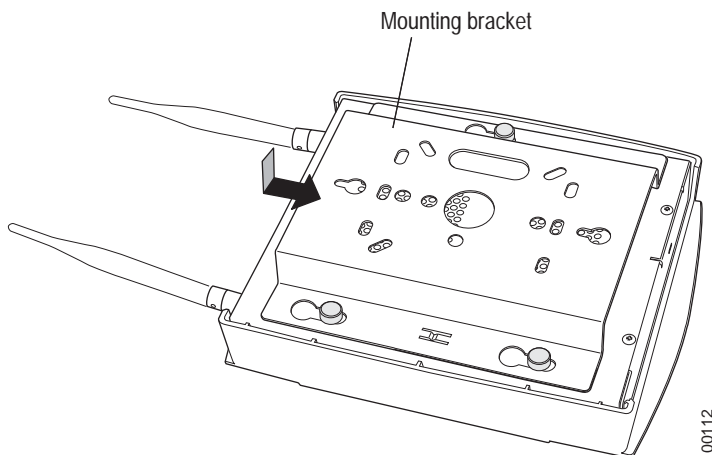

Figure 20: Sliding the AP200 into the Bracket



8. For external antennas, loosen the knurled ring at the base of each antenna (see [Figure 16](#)), point the antenna straight up, then retighten the ring.
9. Connect one end of the PoE 100BaseT Ethernet cable to the 100/1000 Ethernet connector, shown in [Figure 17](#).



**Note:** For the AP201 and AP208 access point, a shielded Cat 5e (or greater) Ethernet cable must be used in order to comply with international electromagnetic emissions limits.



**Caution!** Be sure to connect the Ethernet cable to the Ethernet port; the cable can mistakenly be plugged into the Console port.

## Mounting Below a Suspended Ceiling

The optional suspended ceiling mounting kit allows the AP200 mounting bracket to attach to suspended ceiling T-rails (see [Figure 21](#)).



**Note:** To comply with NEC code, attach a grounding wire to any of the screws used to attach the AP200 to the mounting bracket.

Figure 21: Mounting the AP200 to a Suspended Ceiling Rail

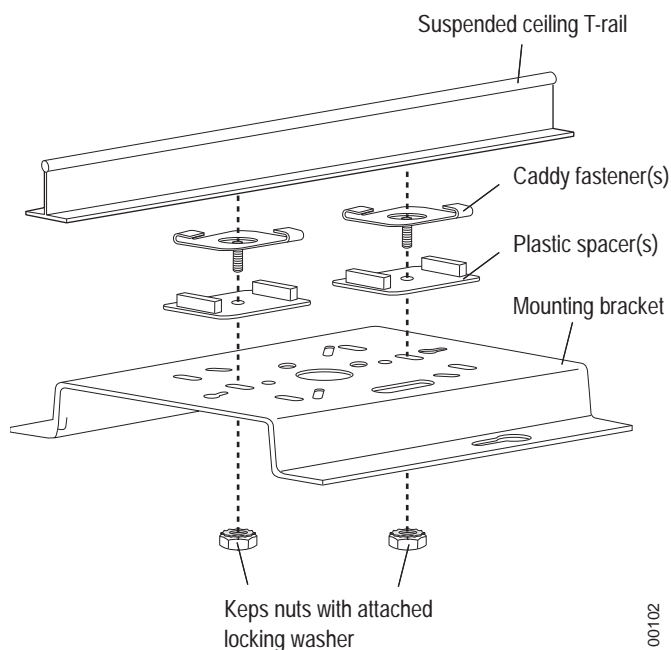

To mount an AP200 below a suspended ceiling:

1. Determine the location on the ceiling rail where the AP will be mounted and remove the ceiling tiles.
2. Place each of the two caddy fasteners on the ceiling T-rail and twist to attach to the rail.
3. Adjust the distance between the caddy fasteners by using the mounting bracket holes as a guide.

4. Tighten the caddy fasteners in place using a standard screwdriver. Do not overtighten.
5. Place each spacer on the caddy fastener stud. The spacer legs should contact the ceiling T-rail.
6. Align the mounting bracket keyholes with the caddy fastener studs and slide the AP200 to the narrow end of the hole.
7. Attach a keps nut to each caddy fastener stud and hand tighten. Do not overtighten.
8. Align the AP200 mounting posts over the circular portion of the keyhole mounts, push the AP in and slide the AP down until it engages with the locking detents (see [Figure 20](#)). You should hear it snap in place.
9. For each antenna, loosen the knurled ring at the base of the antenna (see [Figure 16](#)), point the antenna straight down, then retighten the ring.
10. Connect one end of the PoE 100BaseT Ethernet cable to the 100/1000 Ethernet connector, shown in (see [Figure 17](#)).

**Note:**

For the AP201 and AP208 access points, a shielded Cat 5e (or greater) Ethernet cable must be used in order to comply with international electromagnetic emissions limits.

If it is not practical to use shielded cables, contact Support for a line filter, available at no charge, that may also be used to ensure compliance.



**Caution!** Be sure to connect the Ethernet cable to the Ethernet port; the cable can mistakenly be plugged into the Console port.

## Mounting Above a Suspended Ceiling

The optional T-bar box hanger mounting kit allows the AP200 to be mounted above suspended ceiling T-rails (see [Figure 22](#)). The installation attaches the T-bar box hanger to the ceiling rails using clips. The AP200 attaches to the mounting bracket that is attached to the T-bar box hanger.

The AP200 antennas should point straight down for this type of installation. You may need to modify thicker tiles to support this installation.



**Warning!** When installed in air-handling spaces, such as above a suspended ceiling, the AP200 is to be powered via PoE only (PoE is required).



**Warning!** The AP200 with the metal enclosure exposed meets the requirements for fire resistance and low smoke-generating characteristics required by Section 300-22(C) of the National Electrical Code (NEC) for installation in a building's environmental air space. You must remove the plastic enclosure to reveal the plenum-rated AP200 metal case for installations above a suspended ceiling.

Additionally, you must use Ethernet cable that meets the requirements for operating in plenums and environmental air space (in accordance with Section 300-22(C) of the NEC).



**Warning!** Any Fast Ethernet (FE) cables installed in air-handling spaces should be suitable under NEC Article 800.50 and marked accordingly for use in plenums and air-handling spaces with regard to smoke propagation, such as CL2-P, CL3-P, MPP (Multi Purpose Plenum), or CMP (Communications Plenum).

Figure 22: Mounting the AP200 Above a Suspended Ceiling

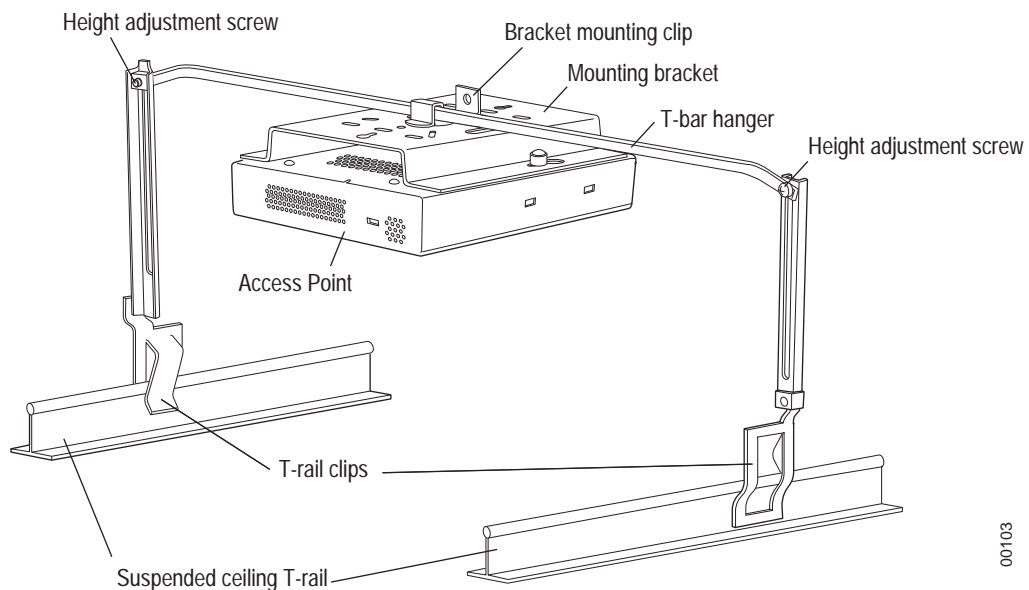

To mount an AP200 above suspended ceiling rails:

1. Determine the location on the ceiling rails where the AP will be mounted and remove the ceiling tile.
2. Unpack the T-bar hanger kit and unfold the legs of the T-bar hanger.
3. Locate the bracket mounting clip holes on the mounting bracket (see [Figure 23](#)). One hole attaches the bracket perpendicular to the box hanger; the other mounts the bracket parallel to the box hanger.

Figure 23: Box Hanger Mounting Bracket Holes

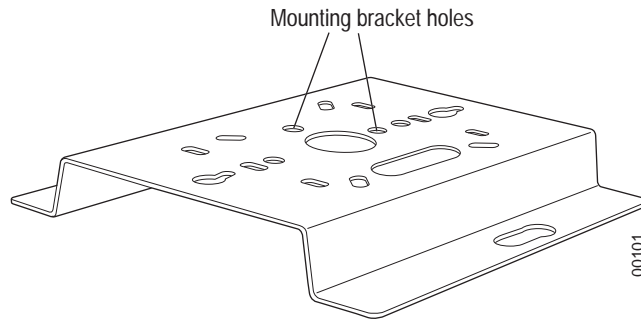

4. Attach the U-joint of the clip to the T-bar and snap in place (see [Figure 24](#)).

Figure 24: Attaching the Mounting Bracket to the Box Hanger

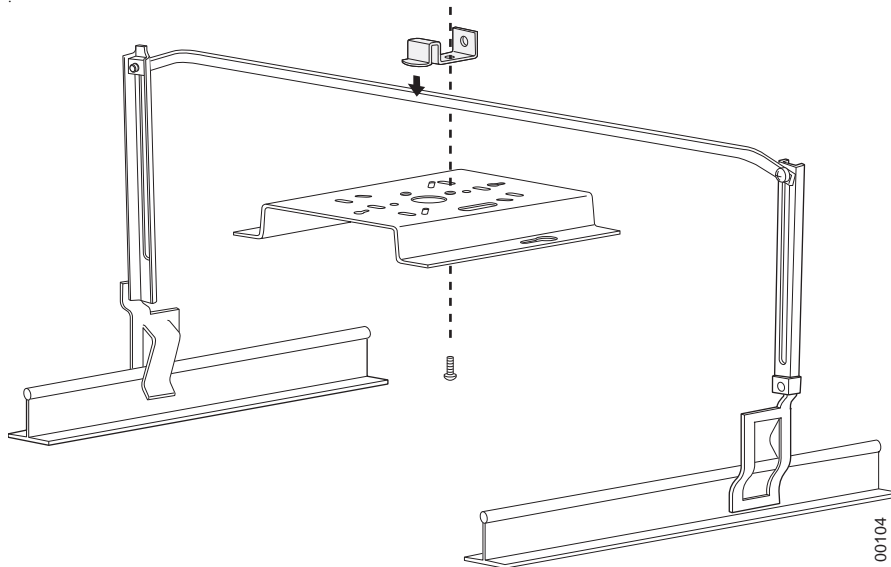

5. Pass the long end clip through the large center hole to the underside of the mounting bracket clip and then attach the bracket to the clip using the supplied screw (see [Figure 24](#) for orientation).

6. Hold the AP200 next to the mounting bracket to estimate the height of the T-bar box hanger to provide enough clearance for the external antennas, which should be pointing down.
7. Adjust the height of the box hanger using the height adjusting screws (see [Figure 21](#)).
8. Clip the box hanger T-rail clips to the ceiling rails, making sure they are securely attached.
9. Connect a drop wire to a building structural element and through the hole provided in the bracket mounting clip. The U.S. National Electrical Safety Code requires this additional support.
10. Connect the posts of the AP200 to the three keyholes of the mounting bracket and slide into the keyhole (see [Figure 20](#)), ensuring the locking detent is engaged. You will hear a click.
11. For each antenna, loosen the knurled ring at the base of the antenna (see [Figure 16](#)), point the antenna down, then retighten the ring.
12. Connect one end of the PoE 100BaseT Ethernet cable to the 100/1000 Ethernet connector, shown in [Figure 17](#).



**Note:**

For the AP201 and AP208 access points, a shielded Cat 5e (or greater) Ethernet cable must be used in order to comply with international electromagnetic emissions limits. If it is not practical to use shielded cables, contact Support for a line filter, available at no charge, that may also be used to ensure compliance.



**Note:**

For the AP201 and AP208 access points, a shielded Cat 5e (or greater) Ethernet cable must be used in order to comply with international electromagnetic emissions limits.



**Caution!** Be sure to connect the Ethernet cable to the Ethernet port; the cable can mistakenly be plugged into the Console port.

13. Check that the AP200 is operating correctly before replacing the ceiling tile to the ceiling. Verify correct operating using the LEDs, as shown in [Checking LED Activity](#).

## Where to Go From Here

---

Now that the AP200 is installed, go to the *Meru System Director Getting Started Guide* for instructions on initializing the hardware. Return to this chapter to check the status of the LEDs once the WLAN is operational.



# Checking LED Activity

Access point status LEDs are provided on the Ethernet connector and on the face of the AP200.

## Ethernet Connector LEDs

After the AP200 is connected, the LEDs near the RJ-45 connector should light, as shown in [Figure 25](#).

Figure 25: RJ-45 LEDs

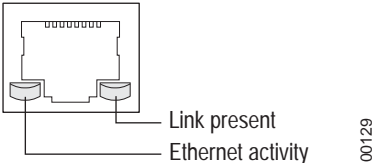

The green LED on the left blinks if any Ethernet activity is taking place. If there is no Ethernet activity, the LED is off. The LED on the right is solid green if an Ethernet link is present. If no Ethernet link is present or connectivity is lost, the LED is off.

## AP200 Status LEDs

Four status LEDs on the *face* of the AP200 also light, as shown in [Figure 26](#).

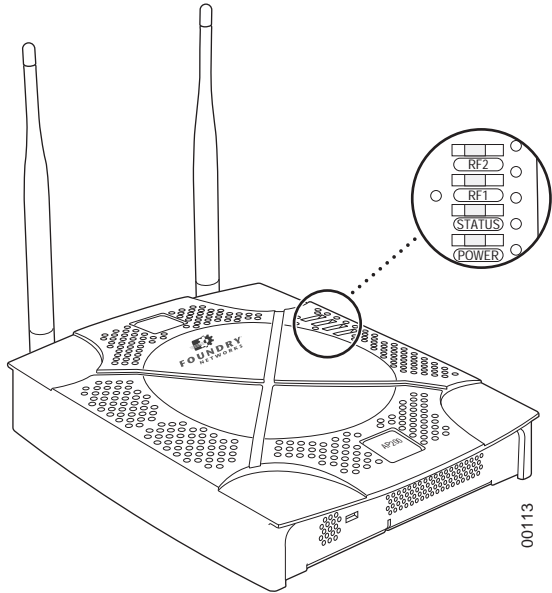
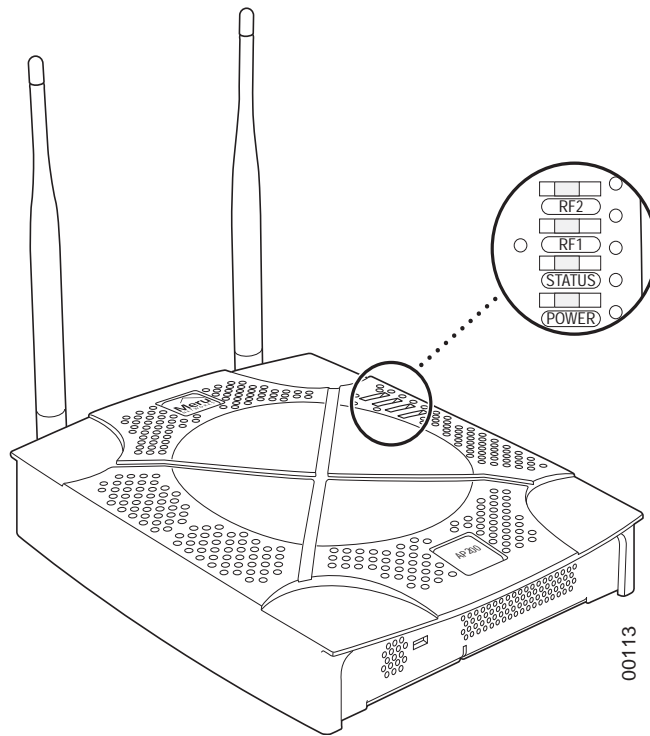

Figure 26: AP200 Status LEDs



The functions of the status LEDs are described below.

When the AP200 is first connected to the controller and any time the access point is rebooted thereafter, the AP initializes with and then is programmed by the controller. When the AP is first powered up, all LEDs are green. Thereafter, the Status LED (see [Figure 26](#)) color reflects the various operating states as described in the second table below.

### AP200 LED Descriptions

LED	Function
RF 2	The status LED for Radio 2 is a follows: off—no radio present yellow—radio initializing red—radio failure solid green—radio OK blinking green—radio activity
RF 1	The status LED for Radio 1 is a follows: off—no radio present yellow—radio initializing red—radio failure solid green—radio OK blinking green—radio activity
Status	AP-Controller operational status (see <a href="#">Table</a> )
Power	green—presence of power

### AP200 Controller Status Information

State	Interpretation	AP200 LED Cycle
Attempting to discover Controller	In the process of discovering the controller. The AP is connected but not associated with the controller. If the AP does not associate with the controller after a period of time, verify that the connection between the AP and the switch or the switch and the controller is unbroken.	Green/Red/Blue/Red
Connected	Normal operation without security.	Blue/Blue/Blue/Red Blue/Blue/Blue/Red, for 2 seconds.
Authenticated	Normal operation with security.	Blue blink <sup>a</sup>

Checking LED Activity

State	Interpretation	AP200 LED Cycle
Disconnected	Access point was once connected to a controller and configured by the controller, but can no longer find that controller	Green/Purple/ Green/Purple
Standalone Remote	Access point is operating in a standalone mode	Purple blink
Downloading	Downloading image or configuration from the controller	Green/Blue Green/Blue
Error State	Access point is in an error state. Call Meru technical support	Red (blinking or solid)

a. The AP200 LEDs cycle from bright to dim for each "blink."

# Chapter 5

## Installing AP150

This chapter describes how to physically install an AP150. It contains the following sections:

- [Safety Precautions](#)
- [Unpacking the AP150](#)
- [Installation Requirements](#)
- [Installing the Access Points](#)
- [Where to Go From Here](#)
- [Checking LED Activity](#)

## Safety Precautions

---

**IMPORTANT**—Read and follow the instructions in Appendix , “Regulatory Information” on page 109 before installing and operating this product.

This product is intended to be supplied by a UL Listed power supply, marked Class 2 or LPS, and rated minimum 5 Vdc, 3A.



**Caution!** The AP150 is not certified for plenum installations, and should not be installed in the plenum space.

## Unpacking the AP150

---

Confirm that the AP150 shipping package contains the AP150 access point with attached mounting bracket.

Figure 27: AP150 with Mounting Bracket

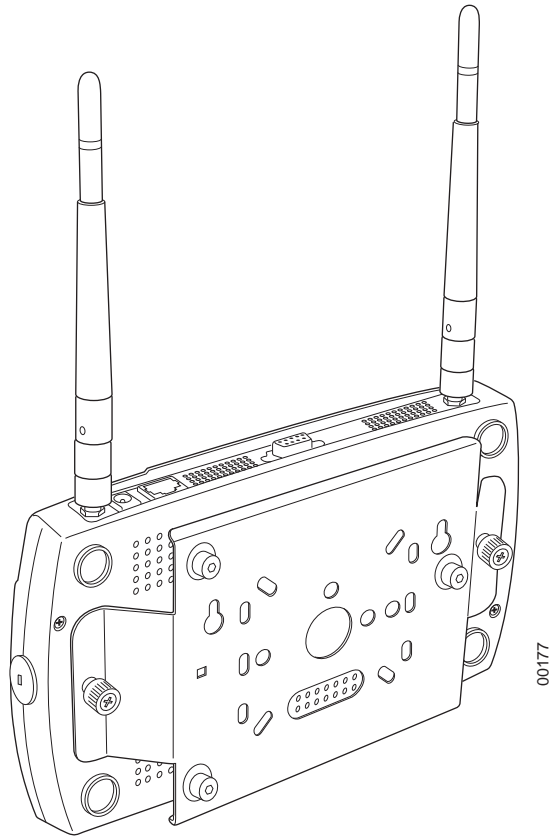

## Installation Requirements

---

If you choose not to use the AP150 mounting bracket, the backside of the AP150 contains two keyholes to accommodate a simple wall mount.

A mounting bracket can be used for many wall mounting configurations. The AP150 bracket mounting studs are placed so they can be used with brackets supplied by other vendors or to replace an AP100. An array of holes on the mounting bracket (see [Figure 27](#)) allow it to be mounted on the wall and over junction boxes or molly bolts. There are also holes for passing the PoE Ethernet or external power supply cable through the bracket if the bracket is mounted on a junction box.

Additional optional mounting kits are available for mounting the AP150 above or below a hanging ceiling, using the mounting bracket.



**Caution!** The AP150 is not certified for plenum installations, and should not be installed in the plenum space.



**Note:** The AP150 has two security cable slots (one on each side of the AP150) so you can secure the AP150 with a standard security cable, such as those used to secure laptop computers.

The following recommended mounting locations provide the best reception for the AP150:

- On a horizontal surface, such as a table or a desk
- On a vertical surface, usually a wall
- Below a hanging ceiling
- Above hanging ceiling tiles

*Suitable for use in environmental air space in accordance with the Section 300-22(c) of the National Electric Code and Sections 2-128.12 - 010 (3) and 12 - 100 of the Canadian Electrical Code. Part 1. C22. 1.*

To complete this installation, you need the items listed in [Table](#) .

AP150 Installation Items

Installation Type	Consumable Items Required
Horizontal mounting	None
Vertical mounting over a wall stud	<ul style="list-style-type: none"> <li>● Two #6 x 2" wood screws for a wood stud; or</li> <li>● Two #6 x 1½" metal screws for a metal stud</li> <li>● Mounting bracket</li> </ul>
Vertical mounting on sheetrock	<ul style="list-style-type: none"> <li>● Two #6 x 1" screws</li> <li>● Two #4-6 x 7/8" ribbed plastic wall anchors</li> <li>● Mounting bracket</li> </ul>
Horizontal mounting below a hanging ceiling	<ul style="list-style-type: none"> <li>● Two caddy fasteners</li> <li>● Two plastic spacers</li> <li>● Two keps nuts (with attached lock washer)</li> <li>● Mounting bracket</li> </ul>
Mounting above a ceiling tile	<ul style="list-style-type: none"> <li>● Two T-rail clips</li> <li>● One T-box hanger</li> <li>● One bracket mounting clip</li> <li>● Mounting bracket</li> </ul>

You need the tools listed below.



## AP150 Required Tools

Installation Type	Tools Required
Horizontal mounting	None
Vertical mounting over a wall stud	<ul style="list-style-type: none"> <li>● Drill</li> <li>● 1/8" drill bit</li> <li>● Screwdriver</li> <li>● 1/8" Allen wrench</li> </ul>
Vertical mounting on sheetrock	<ul style="list-style-type: none"> <li>● Drill</li> <li>● 3/16" drill bit</li> <li>● Screwdriver</li> <li>● 1/8" Allen wrench</li> </ul>
Horizontal mounting below a hanging ceiling	<ul style="list-style-type: none"> <li>● Screwdriver</li> <li>● Wrench or pliers</li> <li>● 1/8" Allen wrench</li> </ul>
Mounting above a hanging ceiling	<ul style="list-style-type: none"> <li>● Wrench or pliers</li> <li>● Screwdriver</li> <li>● 1/8" Allen wrench</li> </ul>

# Installing the Access Points

---

## Selecting a Location

The AP150 requires a location that meets the following criteria:

- Relatively unobstructed access to the stations the AP serves
- Power over Ethernet (PoE) connection to the network switch servicing the controller.

APs can obtain their power from 802.3af standard Power over Ethernet (PoE)-compatible network switch or PoE power injector installed between the switch and the AP150. AP150 and AP300 work with all switches that support STANDARD 802.3af.

Select a location with minimal physical obstructions between the AP and the wireless stations. In an office with cubicles, mounting the APs below a hanging ceiling or the wall near the ceiling provides the least obstructed communications path. For an external power supply connection, ensure the power source is near to where the AP150 will be mounted.

Most installations receive the best coverage using the following guidelines:

Install APs toward the center of the building.

- Do not install APs near metal objects, such as heating ducts, metal doors, or electric service panels.
- Relative to the ground, orient the antenna up or down, not sideways.



**Note:** The previous guidelines are general guidelines. Each site has its own unique environment. Place access points accordingly. Note that the AP300 Power Adaptor can also be used for AP150.

The AP150 is only intended for installation in Environment A as defined in IEEE 802.3af. All interconnected equipment must be contained within the same building, including the interconnected equipment's associated LAN connection.

## Attaching the AP150 Antennas

The AP150 is provided with external antenna ports. Make sure that all external antennas and their associated wiring are located entirely indoors. The external antennas are not suitable for outside use.

If the AP150 does not have external antennas, attach the antennas to the connectors on the AP150 (see [Figure 28](#)). Rotate the knurled ring at the base of the antenna clockwise to attach the antenna. The ring should be finger-tight.



**Caution!** When changing the orientation of the antennas, be sure to slightly loosen the knurled ring before moving the antenna. Retighten the ring afterward. Otherwise, you might damage the internal cabling in the AP.

## Mounting the Access Point

You can mount an AP150 in the following ways:

- Horizontally, as described in the “Horizontal Mounting” section.
- Vertically, as described in the “Vertical Mounting with the Mounting Bracket” section.
- Below a hanging ceiling, as described in the “Mounting Below a Suspended Ceiling” section.

Note that the AP300 Power Adaptor can also be used for AP150.

- Above a tiled hanging ceiling with the optional ceiling mounting kit.

## Horizontal Mounting

To horizontally mount an AP150:

1. Place the AP150 flat on the horizontal surface.
2. For each antenna, loosen the knurled ring at the base of the antenna (see [Figure 28](#)), point the antenna straight up, then retighten the ring.

Figure 28: AP150 Antenna Connection

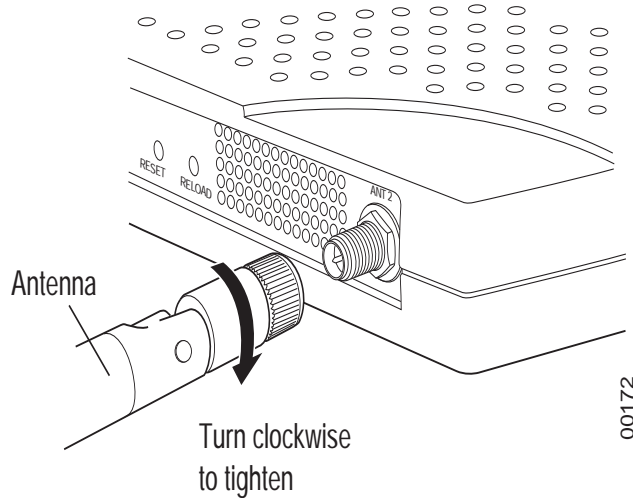

3. Connect one end of the PoE 100BaseT Ethernet cable to the 100/1000 Ethernet connector, shown in [Figure 29](#).

Figure 29: AP150 Connector Panel

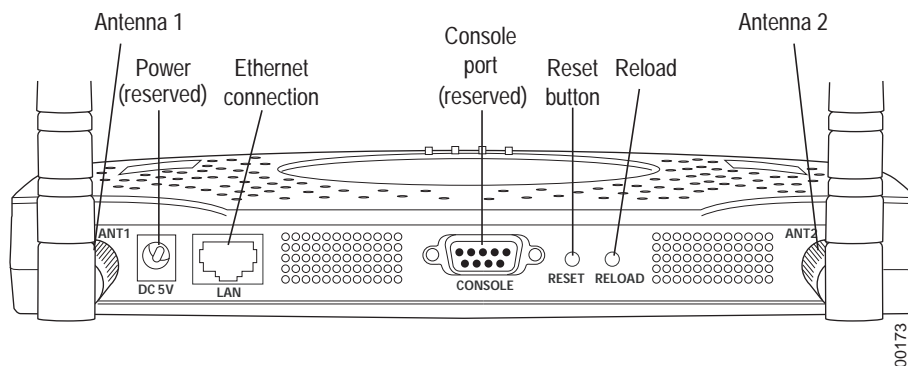

## Vertical Mounting the AP150

To perform a simple wall mount using the keyholes on the back of the AP150:

1. Remove the attached mounting bracket from the back of the AP150.

2. Mark the location on the wall for two mounting screws. They are placed 4.3" apart, center-to-center, or one above the other. If you are not using plastic wall anchors, you must either center the mounting screws on a wall stud or use plastic wall anchors.
3. Drill holes at the locations you marked:
  - 3/16-inch holes if you are using plastic anchors
  - 1/8-inch holes if you are using only the screws
4. If you are using plastic anchors, install them in the holes.
5. Screw in the screws most of the way, so that the screw head is about 1/16 of an inch from the wall.
6. Align the AP150 keyholes over the mounting screws and slightly pull down (or across, if mounting sideways).
7. For external antennas, loosen the knurled ring at the base of each antenna (see [Figure 28](#)), point the antenna straight up, then retighten the ring.
8. Connect one end of the PoE 100BaseT Ethernet cable to the 100/1000 Ethernet connector, shown in [Figure 29](#).

## Vertical Mounting with the Mounting Bracket

The AP150 uses thumbscrews to attach to the mounting bracket or mounting plate that allows the access point to be mounted on a vertical surface. Additionally, three shoulder screws may be installed on the mounting bracket to allow the AP150 and attached bracket to mount over a previously installed Cisco mounting bracket or Proxim AP4000 bracket.

To vertically mount an AP:

1. If not mounting the AP150 to a previously third-party installed mounting bracket, use a 1/8" Allen wrench to remove the shoulder screws from the mounting bracket, if already attached.
2. Using the bracket holes as a template, remove the bracket from the AP150 (or use the stencil in Appendix , "Mounting Bracket Stencils") to mark the location on the wall for the two AP bracket mounting screws. They are placed 4.3 inches apart, center-to-center. If you are not using plastic wall anchors, you must center the mounting screws on a wall stud. If you do not center the mounting screws on a wall stud, you must use plastic wall anchors.

Figure 30: AP150 Bracket

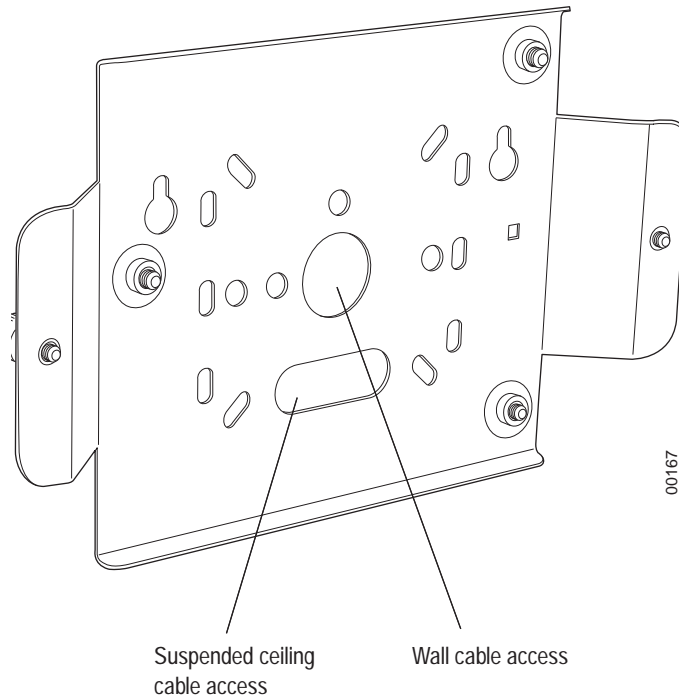

3. Drill holes at the locations you marked:
  - 3/16-inch holes if you are using plastic anchors
  - 1/8-inch holes if you are using only the screws
4. If you are using plastic anchors, install them in the holes.
5. Screw in the screws most of the way, so that the screw head is about 1/16 of an inch from the wall.
6. Mount the bracket on the screws, placing the circular portion of the keyhole mounts over the screw heads and sliding the bracket down.
7. Tighten the screws to secure the bracket.
8. Align the AP150 with the bracket thumbscrews (see [Figure 31](#)) and tighten the thumbscrews to attach the bracket.

Figure 31: Aligning the AP150 with the Bracket

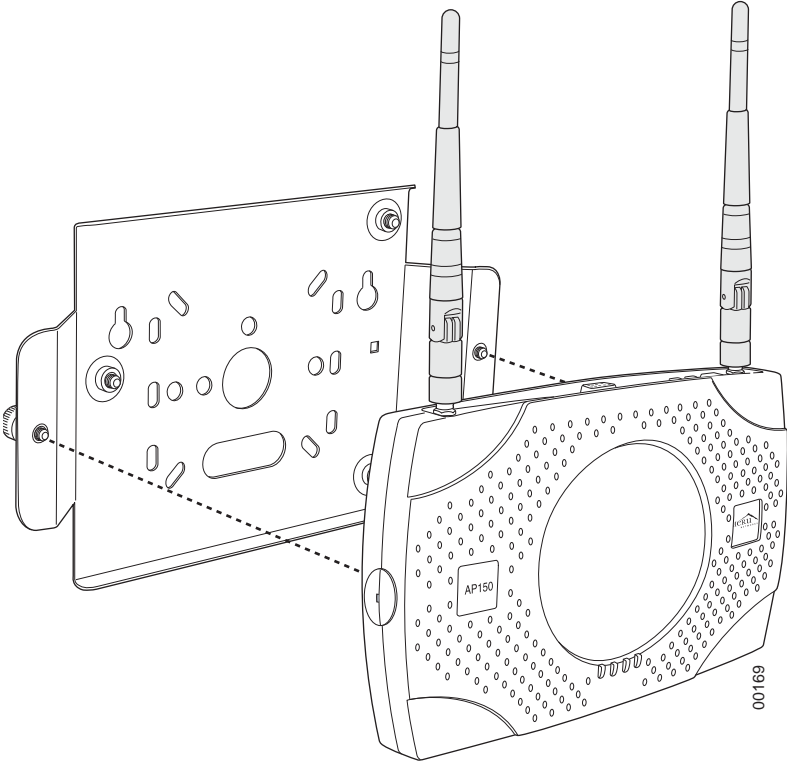

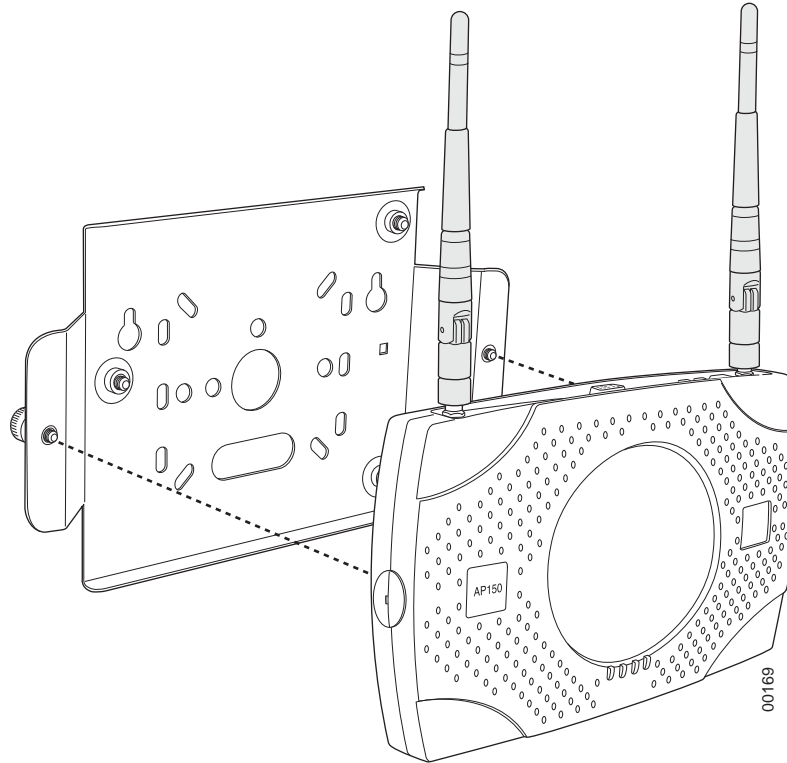

9. For external antennas, loosen the knurled ring at the base of each antenna (see [Figure 28](#)), point the antenna straight up, then retighten the ring.
10. Connect one end of the PoE 100BaseT Ethernet cable to the 100/1000 Ethernet connector, shown in [Figure 29](#).

## Mounting Below a Suspended Ceiling

The optional suspended ceiling mounting kit allows the AP150 mounting bracket to attach to suspended ceiling T-rails (see [Figure 32](#)).

- ✓ **Note:** To comply with NEC code, attach a grounding wire to any of the screws used to attach the AP150 to the mounting bracket.

Figure 32: Mounting the AP150 to a Suspended Ceiling Rail

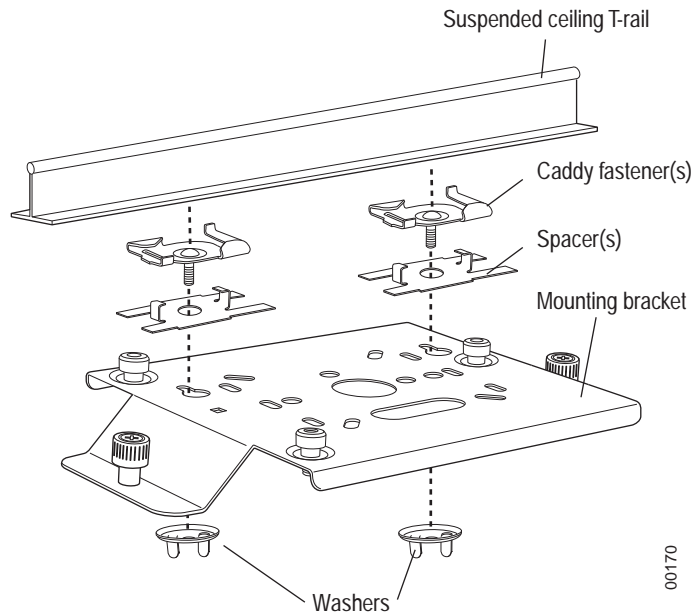

To mount an AP150 below a suspended ceiling:

1. Using a 1/8" Allen wrench, remove the shoulder screws from the mounting bracket, if already attached.
2. Determine the location on the ceiling rail where the AP will be mounted and remove the ceiling tiles.
3. Place each of the two caddy fasteners on the ceiling T-rail and twist to attach to the rail.
4. Adjust the distance between the caddy fasteners by using the mounting bracket holes as a guide.
5. Tighten the caddy fasteners in place using a standard screwdriver. Do not overtighten.
6. Place each spacer on the caddy fastener stud. The spacer legs should contact the ceiling T-rail.
7. Align the mounting bracket keyholes with the caddy fastener studs and slide the AP150 to the narrow end of the hole.
8. Attach a keps nut to each caddy fastener stud and hand tighten. Do not overtighten.
9. Align the AP150 with the bracket thumbscrews (see [Figure 31](#)) and tighten the thumbscrews to attach the bracket.



10. For each antenna, loosen the knurled ring at the base of the antenna (see [Figure 28](#)), point the antenna straight down, then retighten the ring.
11. Connect one end of the PoE 100BaseT Ethernet cable to the 100/1000 Ethernet connector, shown in (see [Figure 29](#)).

## Checking LED Activity

---

Access point status LEDs are provided on the Ethernet connector and on the face of the AP150.

### AP150 Status LEDs

Four status LEDs on the *face* of the AP150 also light, as shown in [Figure 33](#).

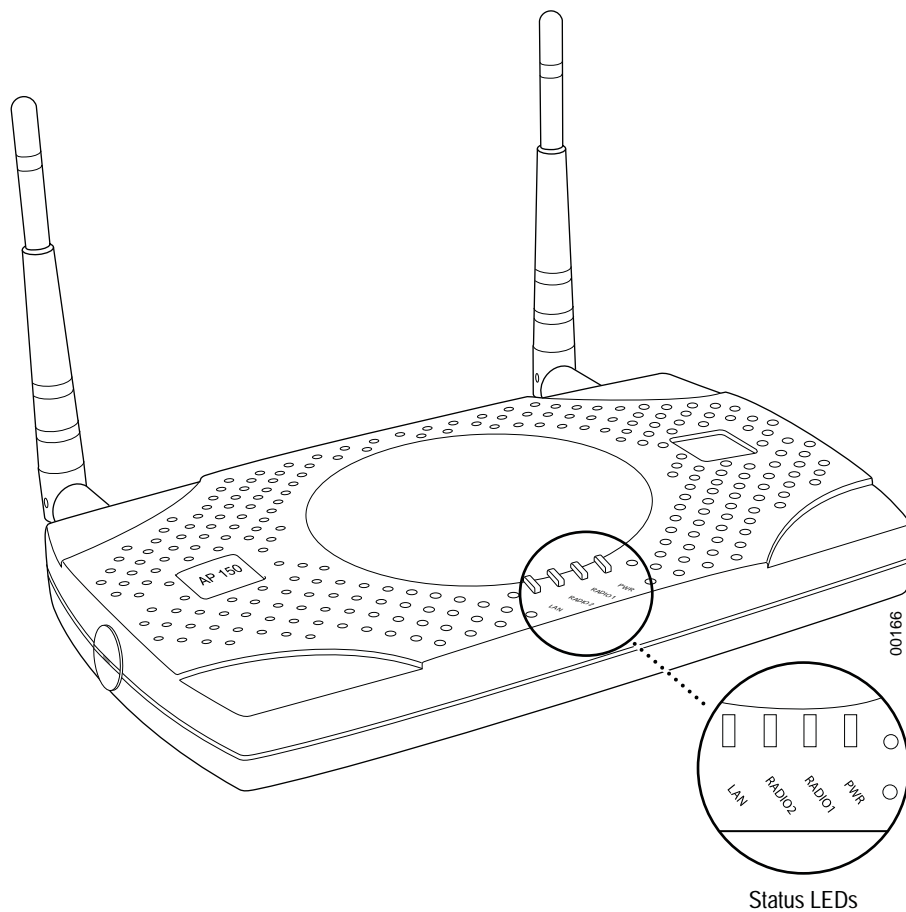
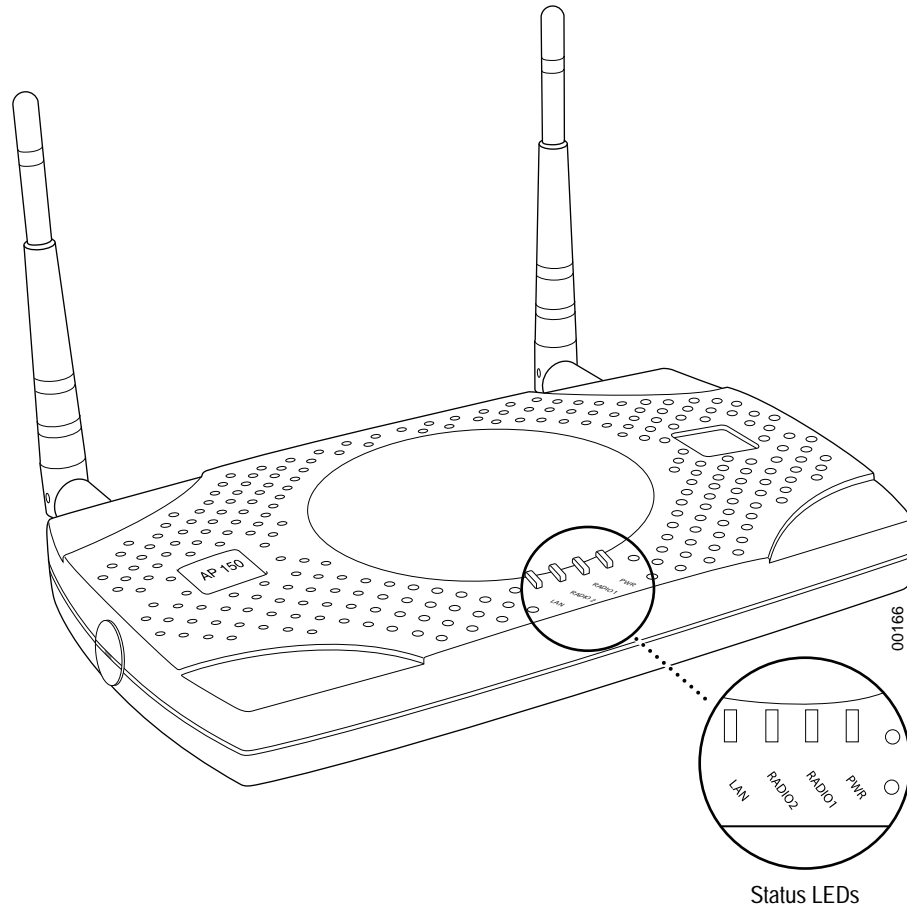

Figure 33: AP150 Status LEDs



When the AP150 is first connected to the controller and any time the access point is rebooted thereafter, the AP initializes with and then is programmed by the controller. The Status LED (see [Figure 33](#)) color reflects the various operating states ([Table](#) ).

## AP150 LED Descriptions

LED	Function
Power	<p>The Power status LED status is as follows:</p> <ul style="list-style-type: none"> <li>• off—power is off</li> <li>• solid red—when power is applied, system initializes for 40 seconds and then the LED turns amber; after discovering the controller the LED turns green. Otherwise, the system is in an abnormal state (notify Customer Support).</li> <li>• solid amber—at any time, if this LED state persists longer than 40 seconds, notify Customer Support</li> <li>• solid green—system is fully operational</li> </ul>
Radio I	The Radio I LED is lit when radio packets are being transmitted and when the radio is beaconing.
Radio II	The Radio II LED is lit when radio packets are being transmitted and when the radio is beaconing.
Ethernet	<p>The Ethernet LED status is as follows:</p> <ul style="list-style-type: none"> <li>• off—no link</li> <li>• solid green—100Mbps connection</li> <li>• blinking green—transmit or receive activity at 100Mbps</li> <li>• solid amber—10Mbps connection</li> <li>• blinking amber—transmit or receive activity at 10Mbps</li> </ul>

## Where to Go From Here

---

Now that the AP150 is installed, go to the *Meru System Director Getting Started Guide* for instructions on initializing the hardware. Return to this chapter to check the status of the LEDs once the WLAN is operational.

Where to Go From Here

# Chapter 6

## Installing OAP180

This chapter describes how to physically install an OAP180. It contains the following sections:

- [Safety Precautions](#)
- [Unpacking the OAP180](#)
- [Installation Requirements](#)
- [Installing the Access Points](#)
- [Where to Go From Here](#)
- [Checking LED Activity](#)

## Safety Precautions

---

**IMPORTANT**—Read and follow the instructions in Appendix , “Regulatory Information” on page 109 before installing and operating this product.

This product is intended to be powered by a UL Listed power supply, marked Class 2 or LPS, and rated minimum 5 Vdc, 3A.

If the installation requires a different supply than the one supplied, make sure you use a supply displaying the mark of the safety agency that defines the regulations of the supply in your country.



**Caution!** The OAP180 is not certified for plenum installations, and should not be installed in the plenum space.

# Unpacking the OAP180

---

**Figure 34: OAP180 Outdoor Access Point**

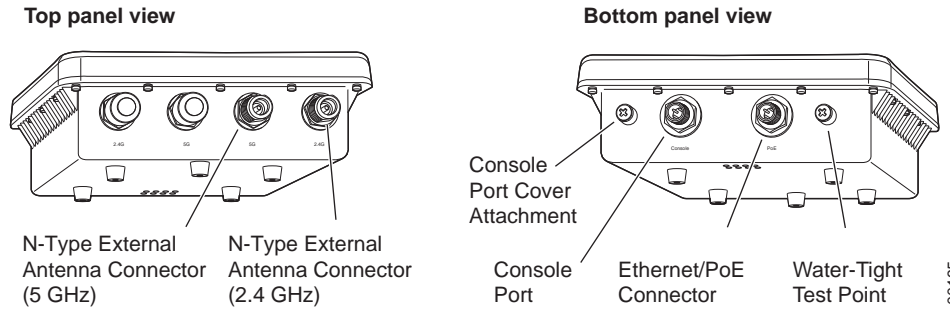

Confirm that the OAP180 shipping boxes contain the following items:

- OAP180 Outdoor Access Point
- Wall/Pole Mount Hardware Kit for mounting OAP180 to a 2” to 3” diameter steel pole or tube or as part of a radio or tower structure
- N-Type Female connectors for external antennas
- Outdoor CAT5 Ethernet cable—100 feet. Be sure to include this (maximum) 100 foot cable in link path calculation; the PoE does not resend the traffic, it only provides power.
- Power injector with power cord

## Installation Requirements

---

In addition to the hardware supplied by Meru Networks, you need the following:

### Required

- Standard Ethernet cable to connect the power injector to a switch or controller
- Antennas (sold separately)

### Ground wire for the OAP180 Optional

- RF coaxial cable to connect the antenna to the OAP180

# Installing the Access Points

## Selecting a Location

When you plan the OAP180 physical configuration, include the elements shown in this drawing:

**Figure 35: Sample Physical Layout**

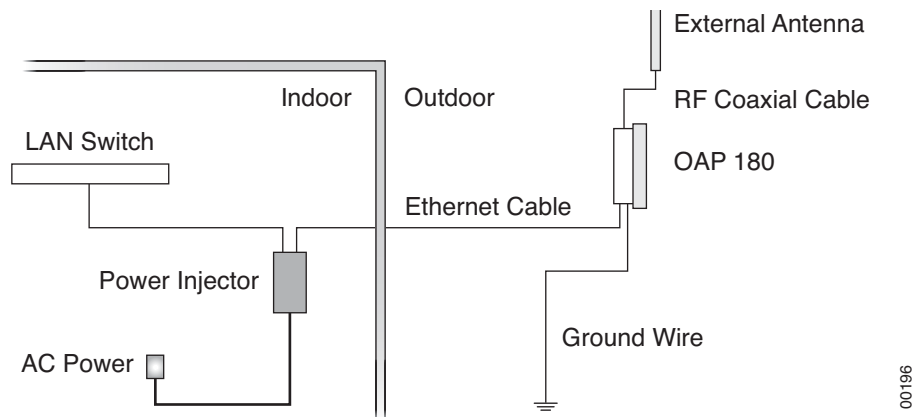

## Radio Position Planning

Never construct a radio mast, pole, or tower near overhead power lines. In addition, local regulations may limit or prevent construction of a high radio mast or tower. If your OAP180 link requires a high radio mast or tower, consult a professional contractor for advice. Once the required antenna height has been determined, other factors affecting the precise position of the OAP180 must be considered.

- Be sure there are no other radio antennas within 2 m (6 ft.) of the OAP180.
- Place the OAP180 away from power and telephone lines.
- Avoid placing the OAP180 too close to any metallic, reflective surfaces, such as roof-installed air-conditioning equipment, tinted windows, wire fences, or water pipes.
- OAP180 has two radios with one antenna per radio, so there is no diversity.

## Radio Interference

Avoiding radio interference is an important part of wireless planning. Interference is caused by other radio transmissions using the same or an adjacent channel frequency. You should first scan your proposed site using a spectrum analyzer to determine if there are any strong radio signals using the 802.11a or 802.11b channel frequencies. Always use a channel frequency that is furthest away from another signal.

## Weather Conditions

Take into account any extreme weather conditions that are known to affect your location. Consider these factors:

- **Temperature** – The OAP180 is tested for normal operation in temperatures from - 40°F to 140°F. Operating in temperatures outside of this range may cause the unit to fail.
- **Wind Velocity** – The OAP180 can operate in winds up to 44 m/s and survive higher wind speeds up to 66 m/s. You must consider the known maximum wind velocity and direction at the site and be sure that any supporting structure, such as a pole, mast, or tower, is built to withstand this force.
- **Lightning** – The OAP180 includes its own built-in lightning surge protection. However, you should make sure that the unit, any supporting structure, and cables are all properly grounded. Additional protection using lightning rods, lightning arrestors, or surge suppressors may also be employed. Antenna sockets should point upwards in a vertical manner
- **Rain** – The OAP180 is weatherproofed against rain. Also, prolonged heavy rain has no significant effect on the radio signal. However, it is recommended to apply weatherproof sealing tape around the Ethernet port and antenna connectors for extra protection. If moisture enters a connector, it may cause a degradation in performance or even a complete failure of the link.
- **Snow and Ice** – Falling snow, like rain, has no significant effect on the radio signal. However, a build up of snow or ice on antennas may cause the link to fail. In this case, the snow or ice has to be cleared from the antennas to restore operation of the link.

## Ethernet Cabling

When a suitable antenna location has been determined, plan a cable route from the OAP180 outdoors to the power injector module indoors. Consider these points:

- The Ethernet cable length should never be longer than 100 ft.
- Determine a building entry point for the cable.
- Determine if conduits, bracing, or other structures are required for safety or protection of the cable.
- For lightning protection at the power injector end of the cable, consider using a lightning arrestor immediately before the cable enters the building.
- The shield of the ethernet cable needs to be grounded at the lightning arrestor. If, by design, the lightning arrestor cannot provide this ground, the shield of the ethernet cable will need to be grounded by the installer.

## Grounding

It is important that the OAP180, cables, and any supporting structures are properly grounded. The OAP180 unit includes a grounding screw to attach a ground wire. Be sure that grounding is available and that it meets local and national electrical codes.



## Test Basic Link Operation

Set up the OAP180 on the ground, either outdoors or indoors. Connect the unit as indicated in this document and perform the basic configuration tasks outlined below.

When you are satisfied that the OAP180 is operating correctly, proceed to mounting the unit in the intended location.

## Mounting the Access Point

The OAP180 can be mounted on the following (brackets are included):

- 2 to 3 inch diameter pole
- Wall

### Mounting OAP180 with the Pole-Mounting Bracket

Be sure to attach antennas (see [Connect Antennas and Ground Wire to OAP180](#)) before mounting an OAP180 on a pole. Follow these steps to mount the unit to a 2 to 3 inch diameter steel pole or tube using the mounting bracket:

1. Attach the OAP180 to the mounting bracket.

**Figure 36: Square Mounting Bracket Attaches to Bottom of OAP180**

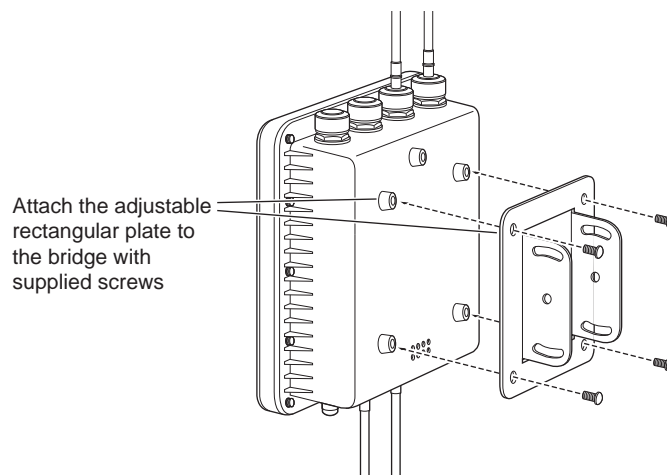

2. Place the V-shaped part of the bracket around the pole and tighten the securing nuts just enough to hold the bracket to the pole. (The bracket may need to be rotated around the pole during the alignment process.)



**Note:** Always attach the bracket to a pole with the open end of the mounting grooves facing up.

**Figure 37: Brackets Attached to a Pole**

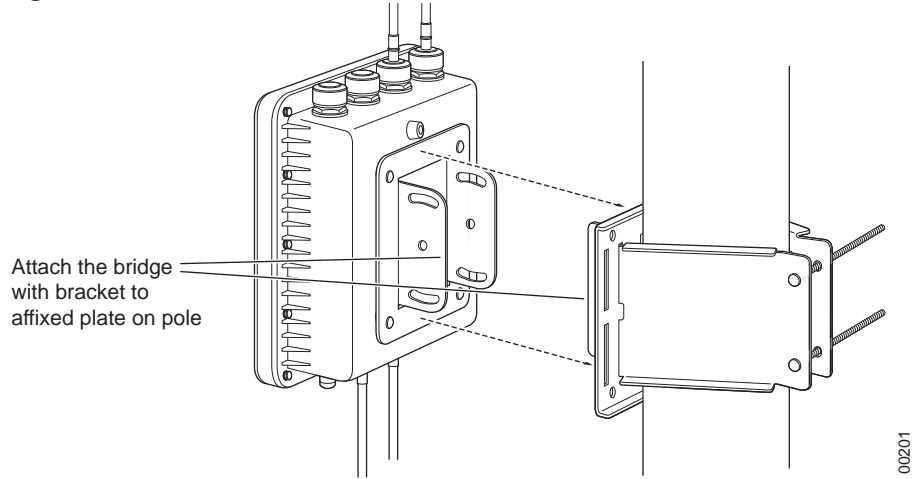

3. Use the included nuts to tightly secure the wireless OAP180 to the bracket.
4. Connect the OAP180 bracket and the pole bracket.

### Mounting OAP180 with the Wall-Mounting Bracket

Attach the bracket to a wall with the flat side flush against the wall. Follow these steps to mount the unit to a wall using the wall-mounting bracket:

1. Position the bracket in the intended location and mark the position of the four mounting screw holes.
2. Drill holes in the wall that match the screws and wall plugs included in the bracket kit, and then secure the bracket to the wall.

**Figure 38: Mount OAP180 Bracket on Wall**

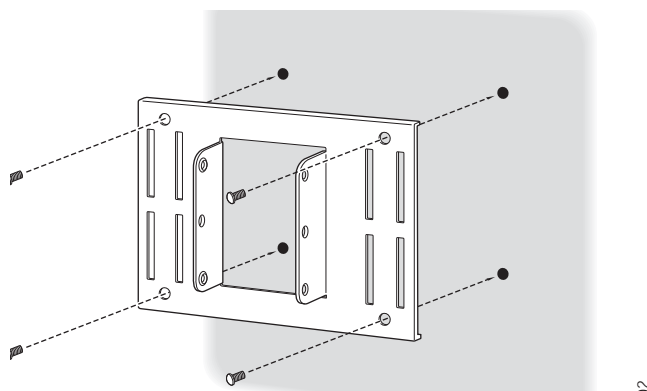

3. Use the included nuts to tightly secure the OAP180 to the bracket.
4. Connect the two brackets as shown below.

Figure 39: Mount OAP180 on Wall Bracket

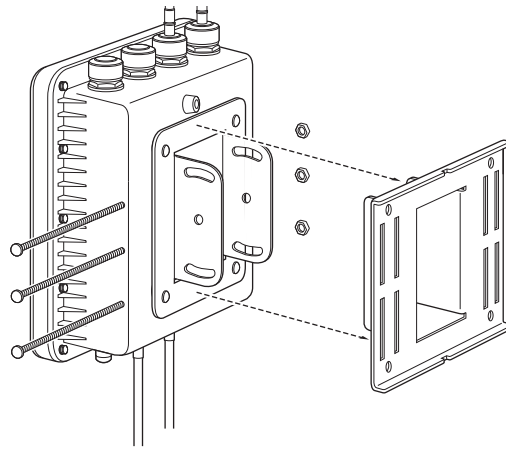

00203

## Connect Antennas and Ground Wire to OAP180

OAP180 does not ship with any antenna by default. Since customers have different outdoor applications, we suggest that you choose from the various antenna options offered by Meru. See the list in Appendix , “AP Accessories” on page 89.

Four antennas are required if diversity is required. You can also use two antennas and terminate the other two. The OAP180 works both with antennas that attach directly to the unit and remote antennas. When using antennas that attach to the unit, attach the antennas before installing the unit. Use the two connectors on the right (5G-1 and 2.4G-1) as indicated in Figure 8. When deploying an OAP180 with a remote antenna, first mount remote antennas and then connect them to the OAP180.

Follow these steps:

1. Remove the two right-most antenna covers indicated in Figure 8.
2. Mount the external antenna on the same supporting structure as you did the OAP180, within 3 m (10 ft.) of it, using the bracket supplied in the antenna package.
3. Connect the antenna to the OAP180’s N-type connector (5G-1 and 2.4G-1) using the RF coaxial cable provided in the antenna box.

Figure 40: Connect OAP180 Antenna Cables

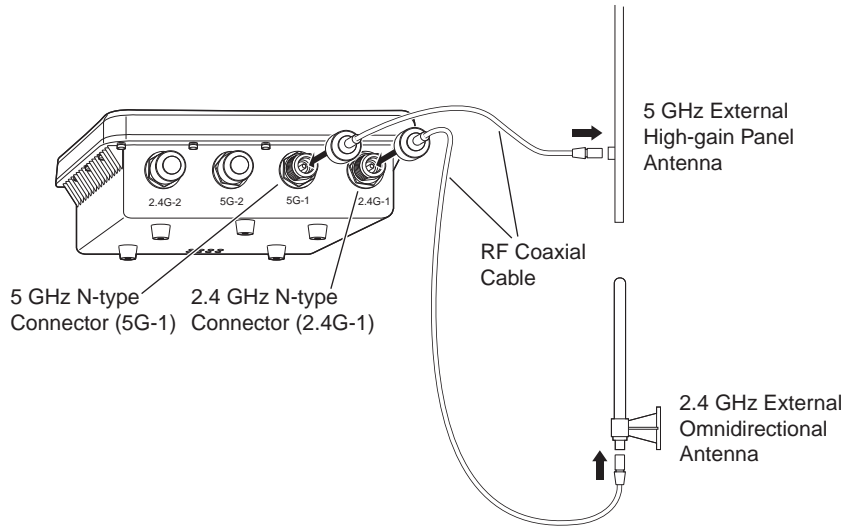

4. Apply weatherproofing tape to the antenna connectors to help prevent water entering the connectors.



**Note:** When not using antenna connectors on the OAP180, keep the covers securely attached for weather protection.

Follow these steps to attach the Ethernet cable and ground wire:

1. Using the included cable, attach the Ethernet cable to the Ethernet port on the OAP180.



**Note:** Use only the provided Ethernet cable. Do not shorten this cable as the path loss is needed. During periods of lightning activity, do not connect or disconnect cables or otherwise work with the OAP180.

Figure 41: Attach Ethernet Cable to OAP180

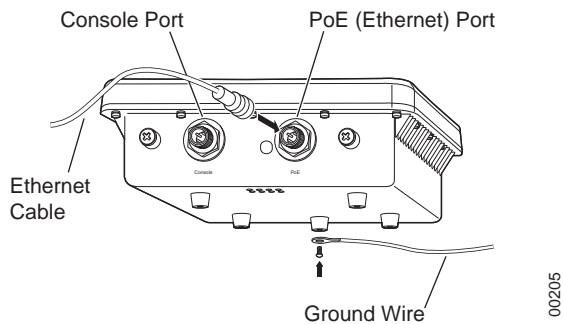

2. For extra protection against rain or moisture, apply weatherproofing tape (not included) around the Ethernet connector.
3. Ground the unit with an appropriate grounding wire (not included) by attaching it to the grounding screw on the unit. See above.



**Caution!** Equipment shall be installed in accordance with the National Electrical Code ANSI/NFPA 70 and the Canadian Electrical Code, Part 1, and when applicable, the National Electrical Safety Code, IEEE C2.

Equipment shall be properly grounded according to Chapter 8 of ANSI/NFPA 70, the National Electrical Code (NEC) and the Cable distribution system should be grounded (earthed) in accordance with ANSI/NFPA 70, the National Electrical Code (NEC), in particular Section 820.93, Grounding of the Outer Conductive Shield of a Coaxial Cable.

The separate protective earthing terminal provided on this product shall be permanently connected to earth.



**Caution!** Do not locate the power injector outdoors. The unit is for indoor use only.



**Note:** The wireless Ethernet port does not support Power over Ethernet (PoE) based on the IEEE 802.3af standard. Do not try to power the unit by connecting it directly to a network switch that provides IEEE 802.3af PoE. Always connect the unit to the included power injector module to maintain the warranty.



**Note:** Each AC power injector requires 1.5 amps of power at 100-240 volts. When connecting multiple devices to one outlet, be sure to allow 1.5 amps for each AC power adapter.

Follow these steps to connect the power injector:

1. Connect the other end of the provided Ethernet cable (already connected to the OAP180) to the RJ-45 port labeled *Output* on the power injector.

Figure 42: Connect OAP180 to Power Injector

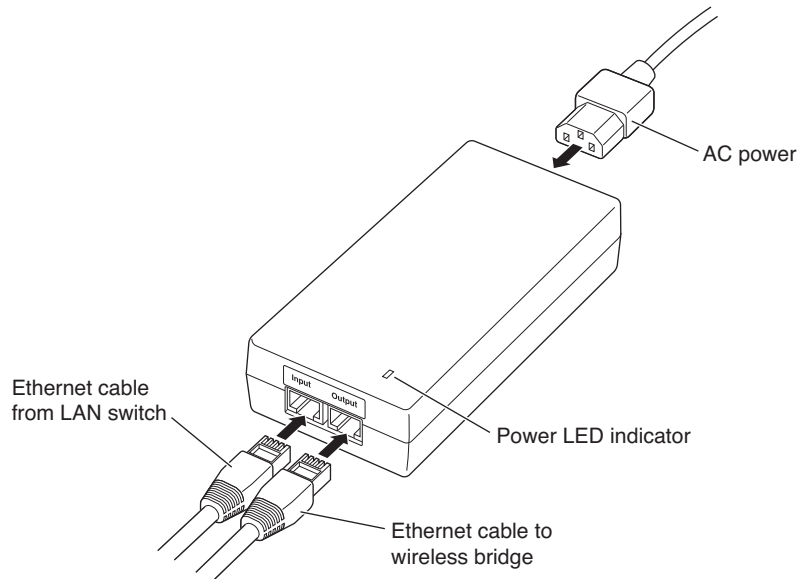

2. Connect a straight-through unshielded twisted-pair (UTP) cable (not included) from a local LAN switch to the RJ-45 port labeled *Input* on the power injector. See the illustration above. Use Category 5e or better UTP cable for 10/100BASE-TX connections.



**Note:** The RJ-45 port on the power injector is an MDI port. If connecting directly to a computer for testing the link, use a crossover cable.

3. Insert the power cable plug directly into the standard AC receptacle on the power injector. See the illustration above.
4. Plug the other end of the power cable into a grounded, 3-pin socket, AC power source.



**Note:** For International use, you may need to change the AC line cord. You must use a line cord set that has been approved for the receptacle type in your country.

5. Check the LED on top of the power injector to be sure that power is being supplied to the OAP180 through the Ethernet connection.

## Align Antenna

After the OAP180 unit is mounted, connected, and the radios are operating, the antennas must be accurately aligned to ensure optimum performance of the OAP180 links. In this point-to-multipoint configuration all OAP180 nodes must be aligned with the root OAP180 antenna.

# Checking LED Activity

Check the OAP180 LEDs for activity. Four of the eight LEDs on the bottom of the OAP180 indicate activity; four LEDs are not used at this time. Check the four active LEDs to determine if the AP is working.

**Figure 43: OAP180 LEDs**

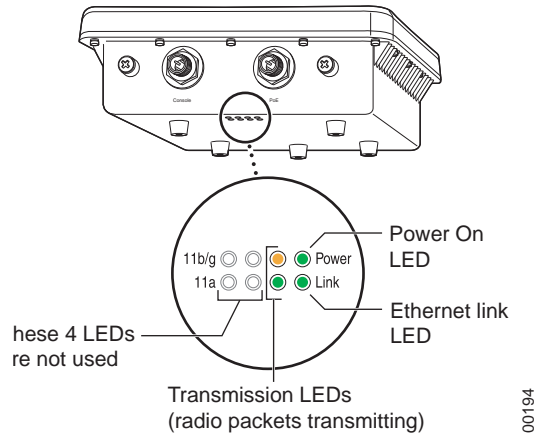

The grey LEDs in the illustration are not currently used. The following chart explains the meanings for the remaining LEDs.

LED	Function
Power	When power is applied, this LED initially turns amber, then blinks green when the system power check is applied, and then is a steady green when power is on.
Radio 1 802.11b/g	The 11bg connection LED blinks amber when radio packets are being transmitted and when the radio is beaconing. If there is traffic over the air on this radio, the blinking rate increases.
Radio 2 802.11a	The 11a connection LED blinks green when radio packets are being transmitted and when the radio is beaconing. If there is traffic over the air on this radio, the blinking rate increases.
Ethernet	The Ethernet Link LED blinks green when a link has been detected and is in use.

## Antenna Gain Recommendations

The OAP180 auto-adjusts the power level sent from the radio to the antenna, so that the EIRP emitted from the antenna is the value defined by the controller (100mW by default). You can increase this setting if you are compensating for signal loss from long inexpensive cables connecting external antennas. (Configure a false/low dBi antenna gain to trick the radio into supplying more transmit power to that antenna, which would then make up for the cable loss.) You may also need to decrease the EIRP from 100mW to 30mW for a device that only transmits at 30mW. The Antenna Gain values can be changed from the Web UI Configuration > APs > Antenna Properties view, or from the CLI using the antenna-property command. Determine the appropriate gain for your antenna by checking the following chart.

Antenna	Gain
MN-ACC-ANT-BG08O-NM 802.11 b/g 8 dBi Omni-Directional Antenna, 2400 - 2500GHz (N Male)	8
MN-ACC-ANT-BG08O-NF 802.11 b/g 8 dBi Omni-Directional Antenna, 2400 - 2500GHz (N Female)	8
MN-ACC-ANT-BG18P-NF 802.11 b/g 18 dBi High Gain Panel Directional Antenna, 2400 - 2500GHz (N Female)	18
MN-ACC-ANT-BG10S-NF 802.11 b/g 10 dBi High Gain Sector Antenna, 2400 - 2500GHz (N Female)	10
MN-ACC-ANT-A08O-NM-1 802.11a 8 dBi Omni-Directional Antenna, 5150 - 5350GHz (N Male)	8
MN-ACC-ANT-A08O-NM-2 802.11a 8 dBi Omni-Directional Antenna, 5470 - 5875GHz (N Male)	8
MN-ACC-ANT-A08O-NF 802.11a 8 dBi Omni-Directional Antenna, 4900 - 5350GHz (N Female)	8
MN-ACC-ANT-A23P-NF 802.11a 23 dBi High Gain Directional Panel, 5150 - 5875GHz (N Female)	23
MN-ACC-ANT-A13S-NF 802.11a 13 dBi High Gain 120-degree Sector Antenna, 4900-5150/5150-5875GHz (N Female)	12.5/13.5



## Where to Go From Here

---

Now that the AP300 is installed, go to the *Meru System Director Getting Started Guide* for instructions on initializing the hardware. Return to this chapter to check the status of the LEDs once the WLAN is operational.

As well, check the AP chapter in the *Meru System Director Configuration Guide* for instructions on configuring radio band, dual radio, and external antenna operation.

Where to Go From Here

# Appendix A

## Cautions and Warnings

The cautions and warnings that appear in this manual are listed below in English, German, French, and Spanish.

### Cautions

---

A Caution calls your attention to a possible hazard that can damage equipment.

"Vorsicht" weist auf die Gefahr einer möglichen Beschädigung des Gerätes in.

Une mise en garde attire votre attention sur un risque possible d'endommagement de l'équipement. Ci-dessous, vous trouverez les mises en garde utilisées dans ce manuel.

Un mensaje de precaución le advierte sobre un posible peligro que pueda dañar el equipo. Las siguientes son precauciones utilizadas en este manual.



**Caution!** When changing the orientation of the antennas, be sure to slightly loosen the knurled ring before moving the antenna. Retighten the ring afterward. Otherwise, you might damage the internal cabling in the AP.

**Vorsicht!** Bei einer Neuausrichtung der Antennen muss vor Bewegung der Antenne der Rändelring leicht gelockert werden. Anschließend den Ring wieder festziehen. Anderenfalls können die internen Kabel im AP beschädigt werden.

**Mise en garde** En cas de modification d'orientation des antennes, veiller à desserrer légèrement la bague moletée avant de réorienter l'antenne. Resserrer ensuite la bague, faute de quoi le câblage interne du point d'accès pourrait être endommagé.

**Precaución!** Al cambiar la orientación de las antenas, asegúrese de aflojar ligeramente el anillo estriado antes de mover la antena. Luego vuelva a apretar el anillo. De otro modo, podría dañar el cableado interno del punto de acceso.



**Caution!** Be sure to connect the Ethernet cable to the Ethernet port; the cable can mistakenly be plugged into the Console port.

**Vorsicht!** Darauf achten, dass das Ethernetkabel am Ethernetanschluss und nicht versehentlich am Konsolenanschluss angeschlossen wird.

**Mise en garde** Veiller à bien connecter le câble Ethernet au port Ethernet et non pas au port Console.

**Precaución!** Asegúrese de conectar el cable Ethernet al puerto Ethernet, porque por error se puede enchufar en el puerto de la consola.



**Caution!** The radiated output power of the access points is well below the FCC radio frequency exposure limits. However, the Meru Access Point should be used in such a manner that the potential for human contact during normal operation is minimized. To avoid the possibility of exceeding the FCC radio frequency exposure limits, you should keep a distance of at least 20 cm between you (or any other person in the vicinity) and the Access Point antennas.

**Vorsicht!** Die abgestrahlte Ausgangsleistung von Geräten von Meru Networks, Inc. liegt weit unter den Hochfrequenz-Expositionsgrenzwerten der FCC. Die Meru Access Point Zugangspunkte von Meru Networks, Inc. sollten jedoch so verwendet werden, dass das Potenzial für Kontakt mit Menschen während des normalen Betriebs auf ein Mindestmaß beschränkt wird. Um die Möglichkeit einer Überschreitung der FCC-Hochfrequenz-Expositionsgrenzwerte zu vermeiden, ist ein Abstand von mindestens 20 cm zwischen Ihnen (bzw. einer anderen Person in der Nähe) und den Zugangspunkt-Antennen zu wahren.

**Mise en garde** La puissance de rayonnement émise par les équipements Meru Networks, Inc. est très inférieure aux limites d'exposition aux fréquences radio définies par la FCC. Toutefois, les points d'accès de la série Meru Access Point de Meru Networks, Inc. doivent être utilisés de façon à éliminer tout risque de contact humain en fonctionnement normal. Pour éviter de dépasser les limites d'exposition aux fréquences radio définies par la FCC, il est impératif de préserver en permanence une distance supérieure ou égale à 20 cm entre l'utilisateur (ou toute personne se trouvant à proximité) et les antennes du point d'accès.

**Precaución!** La potencia de radiación de los dispositivos de Meru Networks, Inc. está muy por debajo de los límites de exposición a radiofrecuencia estipulados por la FCC. No obstante, los puntos de acceso de la serie Meru Access Point de Meru Networks, Inc. deben usarse de tal manera que se minimice la posibilidad de contacto para el usuario durante la operación normal. Para evitar la posibilidad de exceder los límites de exposición a radiofrecuencia establecidos por la FCC, el usuario (o cualquier otra persona en torno) debe mantenerse a una distancia de al menos 20 cm respecto a las antenas del punto de acceso.



**Caution!** Exposure to Radio Frequency Radiation.

The installer of this radio equipment must ensure that the antenna is located or pointed such that it does not emit an RF field in excess of Health Canada limits for the general population; consult Safety Code 6, obtainable from Health Canada's website <http://www.hc-sc.gc.ca/rpb>.

**Vorsicht!** Exposure to Radio Frequency Radiation.

The installer of this radio equipment must ensure that the antenna is located or pointed such that it does not emit an RF field in excess of Health Canada limits for the general population; consult Safety Code 6, obtainable from Health Canada's website <http://www.hc-sc.gc.ca/rpb>.

**Mise en garde** Exposition aux rayonnements à fréquence radioélectrique

L'installateur de cet équipement radio doit veiller à positionner et orienter l'antenne de telle sorte qu'elle n'émette pas un champ radioélectrique supérieur aux limites définies par Santé Canada pour la population générale. Consulter le Code de sécurité n° 6, disponible sur le site Web de Santé Canada à l'adresse <http://www.hc-sc.gc.ca/rpb>.

**Precaución!** Exposición a la radiación de radiofrecuencia.

El instalador de este equipo de radio debe cerciorarse de que la antena está localizada u orientada de tal manera que no emita un campo de radiofrecuencia superior a los límites estipulados por Health Canada para la población; consulte el Código de Seguridad 6 que podrá encontrar en la página web de Health Canada, <http://www.hc-sc.gc.ca/rpb>.

## Warnings

---

A warning calls your attention to a possible hazard that can cause injury or death. The following are the warnings used in this manual.

"Achtung" weist auf eine mögliche Gefährdung hin, die zu Verletzungen oder Tod führen können. Sie finden die folgenden Warnhinweise in diesem Handbuch:

Un avertissement attire votre attention sur un risque possible de blessure ou de décès. Ci-dessous, vous trouverez les avertissements utilisés dans ce manuel.

Una advertencia le llama la atención sobre cualquier posible peligro que pueda ocasionar daños personales o la muerte. A continuación se dan las advertencias utilizadas en este manual.



**Warning!** With plastic covers removed, this product is suitable for use in environmental air space in accordance with the Section 300-22(c) of the National Electric Code and Sections 2- 128.12 - 010 (3) and 12 - 100 of the Canadian Electrical Code. Part 1. C22. 1. For other countries, consult local authorities for regulations.

**Achtung!** Bei abgenommener Kunststoffabdeckung ist dieses Produkt zur Verwendung in einem Umgebungsluftraum gemäß Abschnitt 300-22(c) des National Electric Code und Abschnitt 2- 128.12 - 010 (3) und 12 - 100 des Canadian Electrical Code Teil 1. C22.1 geeignet. Die Vorschriften für andere Länder sind bei den örtlichen Behörden erhältlich.

**Avertissement** Sous réserve que ses couvercles de plastique soient déposés, cet appareil est adapté à une utilisation dans les vides de construction des bâtiments selon la section 300-22(c) du code NEC (National Electric Code) et les sections 2- 128.12 - 010 (3) et 12 - 100 du Code électrique du Canada, partie 1. C22. 1. Pour tous les autres pays, consulter les organismes de réglementation locaux.

**Advertencia** Una vez desprendidas las cubiertas de plástico, este producto es adecuado para su uso en el espacio aéreo circundante en conformidad con la sección 300-22(c) del National Electric Code (Código Eléctrico Nacional de EE.UU.) y las secciones 2- 128.12 - 010 (3) y 12 - 100 del Código Eléctrico de Canadá. Parte 1. C22. 1. En otros países, consulte a las autoridades locales competentes para informarse acerca de las normativas vigentes.



**Warning!** The AP200 with the metal enclosure exposed meets the requirements for fire resistance and low smoke-generating characteristics required by Section 300-22(C) of the National Electrical Code (NEC) for installation in a building's environmental air space. You must remove the plastic enclosure to reveal the plenum-rated AP200 metal case for installations above a suspended ceiling.

Additionally, you must use Ethernet cable that meets the requirements for operating in plenums and environmental air space (in accordance with Section 300-22(C) of the NEC).

**Achtung!** Das AP200 mit exponiertem Metallgehäuse erfüllt die Anforderungen für Feuerbeständigkeit und Kenndaten für geringe Raucherzeugung, die gemäß Abschnitt 300-22(C) des National Electrical Code (NEC) zur Installation im Umgebungsluftraum eines Gebäudes vorgeschrieben sind. Bei Installationen über einem Hängeboden muss das Kunststoffgehäuse abgenommen werden, um das flammwidrige (plenum-rated) AP200 Metallgehäuse freizulegen.

Außerdem muss ein Ethernetkabel, das die Anforderungen zum Betrieb in einem Umgebungsluftraum erfüllt, verwendet werden (gemäß Abschnitt 300-22(C) des NEC).

**Avertissement** L'équipement AP200 en boîtier métallique à nu est conforme aux critères de résistance au feu et de faible génération de fumées de la section 300-22(C) du code NEC (National Electrical Code) pour installation dans le vide de construction d'un bâtiment. Il est nécessaire de déposer le boîtier de plastique pour mettre à nu le boîtier métallique du AP200 en vue de son installation au-dessus d'un faux plafond.

De plus, selon la section 300-22(C) du code NEC, le câble Ethernet doit répondre aux critères de fonctionnement en vide de construction.

**Advertencia** La unidad AP200 con la carcasa de metal expuesta cumple los requisitos de resistencia al fuego y de generación de humo especificados en la sección 300-22(C) del National Electrical Code (NEC, Código Eléctrico Nacional de EE.UU.) para la instalación en el espacio aéreo circundante del edificio. Es necesario desprender la cubierta de plástico con el fin de exponer la carcasa metálica de la unidad AP200 plenum para su instalación encima de techos falsos.

Por otra parte, es necesario utilizar cable Ethernet que cumpla los requisitos de funcionamiento en el espacio aéreo circundante (en conformidad con la sección 300-22(C) del NEC).



**Warning!** Any Fast Ethernet (FE) cables installed in air-handling spaces should be suitable under NEC Article 800.50 and marked accordingly for use in plenums and air-handling spaces with regard to smoke propagation, such as CL2-P, CL3-P, MPP (Multi Purpose Plenum), or CMP (Communications Plenum).

**Achtung!** Alle Fast-Ethernet (FE)-Kabel, die in Lüftungsräumen installiert werden, sollten gemäß NEC Artikel 800.50 geeignet sein und entsprechend zur Verwendung in Hohlräumen (Plenum) und Lüftungsräumen im Hinblick auf Rauchausbreitung gekennzeichnet sein, z.B. CL2-P, CL3-P, MPP (Multi Purpose Plenum) oder CMP (Communications Plenum).

**Avertissement** Les câbles Fast Ethernet (FE) installés dans un vide d'air doivent correspondre aux critères de l'article 800.50 du code NEC et identifiés en conséquence comme adaptés à une utilisation dans les vides de construction des bâtiments en matière de propagation de la fumée (marquages CL2-P, CL3-P, MPP (Multi Purpose Plenum) ou CMP (Communications Plenum)).

**Advertencia** Todos los cables Fast Ethernet (FE) instalados en espacios aéreos deben cumplir con el artículo 800.50 del NEC y estar marcados adecuadamente para su uso en espacios aéreos y plenums en lo concerniente a la propagación de humo, tales como CL2-P, CL3-P, MPP (Plenum multifuncional), o CMP (Plenum de comunicaciones).





**Warning!** Inside antennas must be positioned to observe minimum separation of 20 cm. (~ 8 in.) from all users and bystanders. For the protection of personnel working in the vicinity of inside (downlink) antennas, the following guidelines for minimum distances between the human body and the antenna must be observed.

The installation of the indoor antenna must be such that, under normal conditions, all personnel cannot come within 20 cm. (~ 8.0 in.) from any inside antenna. Exceeding this minimum separation will ensure that the employee or bystander does not receive RF-exposure beyond the Maximum Permissible Exposure according to FCC CFR 47, section 1.1310 i.e. limits for General Population/Uncontrolled Exposure.

**Achtung!** Innenantennen müssen so positioniert werden, dass ein Mindestabstand von 20 cm (ca. 8 Zoll) zu allen Benutzern und anderen Personen gewahrt wird. Zum Schutz von Personal, das in der Nähe von Innenantennen (Downlink) arbeitet, sind die folgenden Richtlinien für Mindestabstand zwischen dem menschlichen Körper und der Antenne zu beachten.

Die Innenantenne muss so installiert werden, dass sich unter normalen Bedingungen kein Personal bis auf weniger als 20 cm (ca. 8 Zoll) an eine Innenantenne annähern kann. Durch Überschreitung dieses Mindestabstands wird sichergestellt, dass Mitarbeiter oder andere Personen keiner RF-Exposition über die maximal zulässige Exposition (MPE; Maximum Permissible Exposure) gemäß FCC CFR 47, Abschnitt 1.1310 (Grenzwerte für die allgemeine Bevölkerung/unkontrollierte Exposition) ausgesetzt werden.

**Avertissement** Les antennes intérieures doivent être positionnées de façon à respecter une distance minimum de 20 cm par rapport aux utilisateurs et aux tiers. Pour la protection du personnel travaillant à proximité des antennes intérieures (liaison descendante), respecter les directives suivantes pour assurer des distances minimales entre les êtres humains et les antennes.

Toute antenne intérieure doit être installée de telle sorte que, dans des conditions normales, le personnel ne puisse s'en approcher à moins de 20 cm. Cette distance minimale est destinée à garantir qu'un employé ou un tiers ne sera pas exposé à un rayonnement radioélectrique supérieur à la valeur maximale autorisée, telle qu'elle est définie dans les limites d'exposition non contrôlées pour la population par la réglementation de la FCC CFR 47, section 1.1310.

**Advertencia** Las antenas interiores deben colocarse de manera que se observe una separación mínima de 20 cm. (~ 8 pulg.) respecto a todos los usuarios y circunstantes. Para la protección del personal que trabaje en las inmediaciones de las antenas interiores (receptoras), deben observarse las siguientes directrices relativas a la distancia mínima entre el cuerpo humano y la antena.

La instalación de la antena interior debe efectuarse de tal modo que, en condiciones normales, ningún miembro del personal pueda acercarse a menos de 20 cm. (~ 8,0 pulg.) de cualquier antena interior. El cumplimiento de este mínimo de separación asegura que el empleado o circunstante no recibirá exposición a radiofrecuencia por encima de la Exposición Máxima Permisible conforme a la normativa FCC CFR 47, sección 1.1310, es decir, los límites asignados a la Exposición Incontrolada/Población Civil.

## Warnings

# Appendix B

## Regulatory Information

The Meru Access Point (APs) must be installed and used in strict accordance with the manufacturer's instructions as described in the user documentation that comes with the product. For country-specific approvals, see below. Meru Networks, Inc. is not responsible for any radio or television interference caused by unauthorized modification of APs, or the substitution or attachment of connecting cables and equipment other than that specified by Meru Networks, Inc. The correction of interference caused by such unauthorized modification, substitution or attachment is the responsibility of the user. Meru Networks, Inc. and its authorized resellers or distributors are not liable for any damage or violation of government regulations that may arise from the user failing to comply with these guidelines.

## For OAP180

---

### Radio

- FCC Part 15
- Canada RSS210
- EN 300 328 V1.6.1 (11/2004)
- EN 301 893 V1.3.1 (08/2005)
- Japan Technical Regulations

### EMC

- FCC Part 15
- EN 301 489-17 V1.2.1 (08/2002)
- Japan VCCI

### Safety

Prolonged exposure to RF radiation can be hazardous. Switch off unit power before service or installation procedures.

### Limits for Occupational/Controlled Exposure

Frequency Range (MHz)	Electric Field Strength (E) (V/m)	Magnetic Field Strength (H) (A/m)	Power Density (S) (mW/cm <sup>2</sup> )	Averaging Time  E  <sup>2</sup> ,  H  <sup>2</sup> or S (minutes)
1500-100,000			5	6

### Limits for General Population/Uncontrolled Exposure

Frequency Range (MHz)	Electric Field Strength (E) (V/m)	Magnetic Field Strength (H) (A/m)	Power Density (S) (mW/cm <sup>2</sup> )	Averaging Time  E  <sup>2</sup> ,  H  <sup>2</sup> or S (minutes)
1500-100,000			1.0	30



**Note:**

Occupational/controlled limits apply in situations in which persons are exposed as a consequence of their employment provided those persons are fully aware of the potential for exposure and can exercise control over their exposure. Limits for occupational/controlled exposure also apply in situations when an individual is transient through a location where occupational/controlled limits apply provided he or she is made aware of the potential for exposure.



**Note:**

General population/uncontrolled exposures apply in situations in which the general public may be exposed, or in which persons that are exposed as a consequence of their employment may not be fully aware of the potential for exposure or can not exercise control over their exposure.

### Frequencies Blocked for Regulatory Compliance

802.11a frequencies 5.25-5.35 GHz and 5.47-5.725 GHz have been blocked for DFS compliance.

# USA

---

## Underwriters Laboratories

For the AP150 series, the AP300 series, AP200 series, and the OAP180, the following statement and notices are applicable:

Use only with Listed I.T.E. equipment.

### Notices

The unit is intended for installation in Environment A as defined in IEEE 802.3.af. All interconnected equipment must be contained within the same building, including the interconnected equipment's associated LAN connection.

Suitable for use in environmental air space in accordance with Section 300-22(c) of the National Electrical Code, and Sections 2-128, 12-010(3) and 12-100 of the Canadian Electrical Code, Part 1, C22.1.

## FCC Radiation Exposure Statement



### Caution!

The radiated output power of the Meru Networks devices is well below the FCC radio frequency exposure limits. However, the Access Point should be used in such a manner that the potential for human contact during normal operation is minimized. When installing and operating these devices, keep a minimum distance of 20 cm (8 inches) between the antennas and any persons/users in the vicinity.

## Radio Frequency Interference Requirements

The Interference Statement applies to the following APs:

- AP150
- OAP180
- AP201 Rev 2, AP208 Rev 2

### FCC Part 15 Statement

This is to certify that the above models are shielded against the generation of radio interference. Compliance is dependent upon the use of Cat 5e shielded data cables or a Meru-supplied line filter. Contact MeruSupport to obtain a line filter, free of charge.

- AP300 series



### Meru Access Points

All devices except the OAP180 are indoor devices. The FCC requires indoor use for the frequency range 5.15 GHz to 5.25 GHz to reduce the potential for harmful interference to co-channel Mobile Satellite systems.

**Note:**

High-power radars are allocated as primary users of the 5.25 to 5.35 GHz and 5.65 to 5.85 GHz bands. These radar stations can cause interference with or damage to these devices, or both.

## Interference Statement

This device complies with Part 15 of the FCC Rules. Operation is subject to the following two conditions: (1) This device may not cause harmful interference, and (2) this device must accept any interference received, including interference that may cause undesired operation.

This equipment has been tested and found to comply with the limits for a Class B digital device, pursuant to Part 15 of the FCC Rules. These limits are designed to provide reasonable protection against harmful interference in a residential installation. This equipment generates, uses, and can radiate radio frequency energy. If the equipment is not installed and used in accordance with the instructions, the equipment may cause harmful interference to radio communications. There is no guarantee, however, that such interference will not occur in a particular installation. If this equipment does cause harmful interference to radio or television reception (which can be determined by turning the equipment off and on), the user is encouraged to try to correct the interference by taking one or more of the following measures:

- Reorient or relocate the receiving antenna.
- Increase the separation between the equipment and receiver.
- Connect the equipment into an outlet on a circuit different from to which the receiver is connected.
- Consult the dealer or an experienced radio/TV technician for help.



**Note:**

The Meru Access Point must be installed and used in strict accordance with the manufacturer's instructions as described in the user documentation that comes with the product. Any other installation or use may violate FCC Part 15 regulations. Modifications not expressly approved by Meru Networks, Inc. could void your authority to operate the equipment.

This device must not be co-located or operating in conjunction with any other antenna or transmitter.

For products available in the USA and Canadian markets, only channels 1 through 11 can be operated. Selection of other channels is not authorized.

# Canada. Industry Canada (IC)

---

The Class B digital portion of this apparatus complies with Canadian standard ICES-003.

These devices comply with RSS210 of Industry Canada.

Per RSS 210 A9.5 point 7:

- (i) the device for the band 5150-5250 MHz is only for indoor usage to reduce potential for harmful interference to co-channel mobile satellite systems;
- (ii) the maximum antenna gain permitted (for devices in the bands 5250-5350 MHz and 5470-5725 MHz) to comply with the e.i.r.p. limit; and
- (iii) the maximum antenna gain permitted (for devices in the band 5725-5825 MHz) to comply with the e.i.r.p. limits specified for point-to-point and non point-to-point operation as appropriate, as stated in section A9.2(3).

In addition, users should also be cautioned to take note that high-power radars are allocated as primary users (meaning they have priority) of the bands 5250-5350 MHz and 5650-5850 MHz and these radars could cause interference and/or damage to LE-LAN devices.

- (iv) These devices are not permitted to operate in the 5600 - 5650 MHz band.

For products available in the USA and Canadian markets, only channels 1 through 11 can be operated. Selection of other channels is not authorized.

Operation is subject to the following two conditions: (1) this device may not cause interference, and (2) this device must accept any interference, including interference that may cause undesired operation of this device.

This device and its listed antenna(s) must not be co-located or operated in conjunction with any other antenna or transmitter

L'utilisation de ce dispositif est autorisée seulement aux conditions suivantes: (1) il ne doit pas produire de brouillage et (2) l'utilisateur du dispositif doit être prêt à accepter tout brouillage radioélectrique reçu, même si ce brouillage est susceptible de compromettre le fonctionnement du dispositif.

The term "IC" before the equipment certification number only signifies that the Industry Canada technical specifications were met.

To reduce the potential radio interference to other users, the antenna type and gain should be chosen so that the equivalent isotropically radiated power (EIRP) is not more than that required for successful communication.

To prevent radio interference to the licensed service, this device is intended to be operated indoors and away from windows to provide maximum shielding. Equipment (or its transmit antenna) that is installed outdoors is subject to licensing.

Pour empêcher que cet appareil cause du brouillage au service faisant l'objet d'une licence, il doit être utilisé à l'intérieur et devrait être placé loin des fenêtres afin de fournir un écran de blindage maximal. Si le matériel (ou son antenne d'émission) est installé à l'extérieur, il doit faire l'objet d'une licence.



**Caution!** **Exposure to Radio Frequency Radiation.**  
 The installer of this radioequipment must ensure that the antenna is located or pointed such that it does not emit an RF field in excess of Health Canada limits for the general population; consult Safety Code 6, obtainable from Health Canada’s website <http://www.hc-sc.gc.ca/rpb>.  
 This equipment complies with IC RSS-102 radiation exposure limits set forth for an uncontrolled environment. This equipment should be installed and operated with a minimum distance of 20cm between the antennas and any persons/users in the vicinity.



**Note:** **Meru Access Points**  
 These devices are restricted to indoor use because they operate in the 5.15 to 5.25 GHz frequency range. Industry Canada requires such products to be used indoors for the frequency range 5.15 GHz to 5.25 GHz to reduce the potential for harmful interference to co-channel Mobile Satellite systems.

Access Points have been designed to operate with the antennas listed below. Antennas not included in this list are strictly prohibited for use with these devices. The required antenna impedance is 50 ohms.

**AP Antennas with Gain**

AP Model	Antenna Type	Gain (2.4 GHz)	Gain (5 GHz)
AP300	Dual-Band Omni-Directional MN-ACC-ANTabg-W	2 dBi	3 dBi
AP300	Dual-Band Omni-Directional ACC-ANT-ABGN-23	2 dBi	3 dBi
AP300	High-Gain Dipole Omni-Directional ACC-ANT-ABGN470	4.7dBi	4.7dBi
AP200	Dual-Band Omni-Directional SAA04-220050	2 dBi	3 dBi
AP200	Dual-Band Omni-Directional TWX-614XRSXX	4 dBi	5 dBi
AP150	Dual-Band Omni-Directional SAA04-220050	2 dBi	3 dBi

To reduce potential radio interference to other users, the antenna type and its gain should be chosen so that the equivalent isotropically radiated power (e.i.r.p.) is not more than that permitted for successful communication.



# Europe—EU Declaration of Conformity and Restrictions

---



This equipment is marked with either the CE Mark, the alert symbol, and the notified body's number and can be used throughout the European Community. This mark indicates compliance with the R&TTE Directive 1999/5/EC and the relevant parts of the following technical specifications.

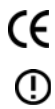

This equipment is marked with either the CE Mark, the alert symbol, and the notified body's number and can be used throughout the European Community. This mark indicates compliance with the R&TTE Directive 1999/5/EC and the relevant parts of the following technical specifications.

**EN 300 328.** Electromagnetic Compatibility and Radio Spectrum Matters (ERM). Wideband transmission systems, data transmission equipment operating in the 2.4 GHz ISM (Industrial, Scientific, and Medical frequency bands in the range of 902-928 MHz, 2.4-2.485 GHz, and 5.15-5.25 GHz) band and using spread spectrum modulation techniques, harmonized EN standards covering essential requirements under article 3.2 of the R&TTE directive.

**EN 301 893.** Broadband Radio Access Networks (BRAN). 5 GHz high-performance RLAN, harmonized EN standards covering essential requirements of article 3.2 of the R&TTE directive.

**EN 301 489-17.** Electromagnetic Compatibility and Radio Spectrum Matters (ERM). Electromagnetic Compatibility (EMC) Standard for Radio Equipment and Services, Part 17 Specific Conditions for Wideband Data and HIPERLAN Equipment.

**EN 55022 Statement** (applicable to AP201 Rev 2, AP208 Rev 2 only). This is to certify that the above models are shielded against the generation of radio interference in accordance with the application of Council Directive 2004/108/EC, Annex I, 1a. Conformity is declared by the application of EN 55022 Class B (CISPR 22). Compliance is dependent upon the use of Cat 5e shielded data cables.

**EN 60950-1.** Safety of Information Technology Equipment.

**EN 50385.** Product standard to demonstrate the compliances of radio base stations and fixed terminal stations for wireless telecommunication systems with the basic restrictions or the reference levels related to human exposure to radio frequency electromagnetic fields.



Marking by the alert symbol indicates that usage restrictions apply.



Marking by the alert symbol indicates that usage restrictions apply.

Meru Networks, Inc. declares that their Access Points comply with the essential requirements and other relevant provisions of Directive 1999/5/EC.

Meru Networks, Inc. vakuuttaa täten että Access Points tyyppinen laite on direktiivin 1999/5/EY oleellisten vaatimusten ja sitä koskevien direktiivin muiden ehtojen mukainen.

Hierbij verklaart Meru Networks, Inc. dat het toestel Access Points in overeenstemming is met de essentiële eisen en de andere relevante bepalingen van richtlijn 1999/5/EG.

Bij deze verklaart Meru Networks, Inc. dat deze Access Points voldoet aan de essentiële eisen en aan de overige relevante bepalingen van Richtlijn 1999/5/EC.

Par la présente, Meru Networks, Inc. déclare que l'appareil Access Points est conforme aux exigences essentielles et aux autres dispositions pertinentes de la directive 1999/5/CE.

Par la présente, Meru Networks, Inc. déclare que ce Access Points est conforme aux exigences essentielles et aux autres dispositions de la directive 1999/5/CE qui lui sont applicables.

Härmed intygar Meru Networks, Inc. att denna Access Points står i överensstämmelse med de väsentliga egenskapskrav och övriga relevanta bestämmelser som framgår av direktiv 1999/5/EG.

Undertegnede Meru Networks, Inc. erklærer herved, at følgende udstyr Access Points overholder de væsentlige krav og øvrige relevante krav i direktiv 1999/5/EF.

Hiermit erklärt Meru Networks, Inc. dass sich dieser/diese/dieses Access Points in Übereinstimmung mit den grundlegenden Anforderungen und den anderen relevanten Vorschriften der Richtlinie 1999/5/EG befindet.

Hiermit erklärt Meru Networks, Inc. die Übereinstimmung des Gerätes Access Points mit den grundlegenden Anforderungen und den anderen relevanten Festlegungen der Richtlinie 1999/5/EG.

Con la presente Meru Networks, Inc. dichiara che questo Access Points è conforme ai requisiti essenziali ed alle altre disposizioni pertinenti stabilite dalla direttiva 1999/5/CE.

Por medio de la presente Meru Networks, Inc. declara que el Access Points cumple con los requisitos esenciales y cualesquiera otras disposiciones aplicables o exigibles de la Directiva 1999/5/CE.

Meru Networks, Inc. declara que este Access Points está conforme com os requisitos essenciais e outras disposições da Directiva 1999/5/CE.

Hawnhekk, Meru Networks, Inc. jiddikjara li dan Access Points jikkonforma mal-htigijiet essenzjali u ma provvedimenti ohrajn relevanti li hemm fid-Dirrettiva 1999/5/EC.

Käesolevaga kinnitab Meru Networks, Inc. seadme Access Points vastavust direktiivi 1999/5/EÜ põhinõuetele ja nimetatud direktiivist tulenevatele teistele asjakohastele sätetele.

Alulírott, Meru Networks, Inc. nyilatkozom, hogy a Access Points megfelel a vonatkozó alapvető követelményeknek és az 1999/5/EC irányelv egyéb előírásainak.

Meru Networks, Inc. týmto vyhlasuje, e Access Points splna základné poiadavky a všetky príslušné ustanovenia Smernice 1999/5/ES.

Meru Networks, Inc. tímto prohlašuje, e tento Access Points je ve shode se základními požadavky a dalšími příslušnými ustanoveními směrnice 1999/5/ES.

Šiuo Meru Networks, Inc. deklaruoja, kad šis Access Points atitinka esminius reikalavimus ir kitas 1999/5/EB Direktyvos nuostatas.

Ar šo Meru Networks, Inc. deklare, ka Access Points atbilst Direktivas 1999/5/EK būtiskajam prasibam un citiem ar to saistitajiem noteikumiem.

Niniejszym, Meru Networks, Inc., deklaruje, ze Access Points spelnia wymagania zasadnicze oraz stosowne postanowienia zawarte Dyrektywie 1999/5/EC.

These products are intended to be used in all countries of the European Economic Area with the following restrictions:

## IEEE 802.11a Restrictions

- These products are for indoor use only (5150-5250 MHz).
- To ensure compliance with local regulations, be sure to set your Access Point to the country in which you are using the Access Point.
- The Meru Access Point products can be used only indoors in the following countries: Austria, Belgium, Bulgaria, Czech Republic, Germany, Cyprus, Denmark, Estonia, Finland, France, Greece, Hungary, Iceland, Ireland, Italy, Latvia, Lithuania, Luxembourg, Malta, The Netherlands, Norway, Portugal, Poland, Romania, Spain, Slovak Republic, Slovenia, Sweden, Switzerland, Turkey, and United Kingdom.

## EEE 802.11b/g Restrictions

- France—In all Metropolitan départements, wireless LAN frequencies can be used under the following conditions, either for public or private use:  
Indoor use: maximum power (EIRP) of 100 mW for the entire 2400-2483.5 MHz frequency band.

# Japan

---

EN 55022 Statement (applicable to AP201 Rev 2, AP208 Rev 2 only). This is to certify that the above models are shielded against the generation of radio interference in accordance with the application of Council Directive 2004/108/EC, Annex I, 1a. Conformity is declared by the application of EN 55022 Class B (CISPR 22). Compliance is dependent upon the use of shielded data cables.

## Model AP300



Model AP300 module rev 1

003WWA080094 003GZA080095 003XWA080096

## Model 208



003NY06089 0000 003GZ06018 0000 003WY06035 0000

## Model 208 Rev 2 Module



003NY07014 0000 003GZ07002 0000 003WY07004 0000

## Model 208 Rev 2 Module



003NY070390000 003GZ070080000 003WY070100000

## Model AP208 Rev 2



003NY07015 0000 003GZ07003 0000 003WY07005 0000

## Model AP208 Rev 2



003NY070380000 003GZ070070000 003WY070090000

## Model 201



003NY06117 0000 003GZ06026 0000 003WY06043 0000

**Model AP201 Rev 2**



003NY07015 0000 003GZ07003 0000 003WY07005 0000

**Model AP201 Rev 2**



003NY070380000 003GZ070070000 003WY070090000

**Model AP150**



003NY06122 0000 003GZ06030 0000 003WY06046 0000

**Singapore**

For the AP201 Rev 2, AP208 Rev 2, and OAP180, the following approval information applies:

**Complies with  
IDA Standards  
DA103798**

For the AP300 series, the following approval information applies:

**Complies with  
IDA Standards  
DB102245**

## Manufacturing Information

---

The AP150, AP200, and AP300 are built in Taiwan. Factory information is provided under NDA and upon request.

# AP300 Plenum Requirements

---

When installing the product in an air-handling space, as described in Article 300.22(C) of the NEC (2005), the unit should only be powered by the Ethernet port (PoE), not by the AC-powered power supply.

When the product is installed in air-handling spaces, the cables employed should be suitable under NEC Articles 300.22 and 725 and marked accordingly, for use in plenums and air-handling spaces with regard to smoke propagation, such as CL2-P, CL3-P, MPP or CMP.

The products should be installed in accordance with all applicable, local regulations and practices.



voice. data. wireless. *Become one.*

---

**Meru Networks, Inc.**

894 Ross Drive

Sunnyvale, CA 94087

408-215-5300

[www.merunetworks.com](http://www.merunetworks.com)