



Meru AP832

Installation Guide

Copyright © Meru Networks, Inc., 2003-2013. All rights reserved.
Other names and brands may be claimed as the property of others.

April 2013

Chapter 2

Installing AP832e

This chapter describes how to install and configure an AP832e. It contains the following sections:

- [Safety Precautions](#)
- [Unpack the AP832e](#)
- [Installation Requirements](#)
- [Install the AP832e](#)
- [Check AP832e LED Activity](#)
- [Where to Go From Here](#)

Safety Precautions

IMPORTANT—Read and follow the regulatory instructions in Appendix B before installing and operating this product.

If an optional power supply is used, it must be one supplied by Meru Networks.



Warning!

This product is intended to be supplied by a UL Listed power supply marked Class 2 or LPS and rated minimum 12Vdc, 2A. For Power over Ethernet, an 802.3af or 802.3at connection must be used.

The AP832e is intended only for installation in Environment A as defined in IEEE 802.3af. All interconnected equipment must be contained within the same building, including the interconnected equipment's associated LAN connection.

Unpack the AP832e

Confirm that the AP832e shipping package contains these items:

Installation Requirements

- AP832e
- Wall mount bracket
- Two ceiling mount brackets (for varying sized ceiling structures)
- Six antennas
- Screws for the mounting bracket

Installation Requirements

An array of holes on the mounting bracket allows the AP832e to be mounted on the wall and over junction boxes or molly bolts. There are holes for passing the PoE Ethernet or external power supply cable through the bracket if the bracket is mounted on a junction box.

The AP832e has a security cable slot so you can lock the AP832e with a standard security cable, such as those used to secure laptop computers.

The AP832e ships with included ceiling and wall mounting brackets to be used for varying types of locations, such as on T-bars or over junction boxes. For mounting above ceiling tiles, purchase optional mounting kits:

- Above Suspended Ceiling Mounting Kit (T-Bar Hanger): MNT-ASCMKIT
- Above hanging ceiling tiles. Suitable for use in environmental air space in accordance with the Section 832e-22(c) of the National Electric Code and Sections 2- 128.12 - 010 (3) and 12 - 100 of the Canadian Electrical Code. Part 1. C22. 1. Note that in order to comply with these standards, the plastic cover on the AP must be removed.

Additional Equipment

A power source is needed to power the AP832e. The AP832e requires an 802.3af or 802.3at power source when operating with PoE. If this is not available, 12V DC power (2A rated) must be supplied.

Antenna Mappings

See [Table 1](#) to determine which radio is associated with each antenna.

Table 1: Antenna Mappings

Antenna	Radio/Channel
1	Radio 1
2	Radio 1
3	Radio 1
4	Radio 2
5	Radio 2
6	Radio 2

Install the AP832e

[Select a Location](#)

[Attach the Provided Antennas](#)

[Install the Access Point](#)

Select a Location

All AP832e interconnected equipment, including the associated LAN connection, must be contained within the same building. In addition, the AP832e location should meet the following conditions:

- Relatively unobstructed access to the stations the AP serves. Select a location with minimal physical obstructions between the AP and the wireless stations. In an office with cubicles, mounting the APs below a hanging ceiling (plenum is supported) or the wall near the ceiling provides the least obstructed communications path. On a wall, orient the AP832e horizontally so that you can read the Meru logo without tilting your head at 90 degrees - this orientation provides optimum MIMO performance.
- Access to wall outlet or a to a Power over Ethernet (PoE) connection to the network switch servicing the controller.
- We recommend planning for about 256 clients per radio (or per interference region) if you plan to use Virtual Port and plan to have phones as clients. Refer to the Meru Deployment Guides on the support site for more information.

AP832e is designed to provide 360 degree omni-directional coverage as illustrated below. Plan placement with this pattern in mind.

Figure 1: Coverage Pattern for AP832e When Ceiling Mounted

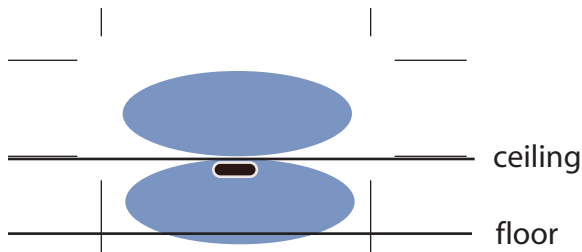

Most installations receive the best coverage using the following guidelines:

- Install APs toward the center of the building.
- Place APs about 80 feet apart.
- Do not install APs near metal objects, such as heating ducts, metal doors, or electric service panels.



Note: When planning to operating multiple radios on the same band (i.e., 2 radios on the 2.4GHz band), it is important that the user reduce the transmit power for each radio by 3dBm from its default setting.

Attach the Provided Antennas

All AP832es have six external antenna ports, labeled 1 - 6. These units operate with six antennas attached, even though some configurations don't use all six. Instead of attaching an antenna, you can cap unused antenna connectors with 50 ohm Reverse Polarity SMA terminators. (For a list of approved terminators, see <http://www.merunetworks.com/merusupport>.) To achieve the best performance from your AP832e, position antennas at a 90 degree angle relative to each other. The antennas do not have to be oriented exactly as shown in the figure, but it is important to maintain the relative angles. If for some reason you are unable to maintain those angles, the network still operates, but you may experience up to 20% drop in throughput depending on the antenna orientation.

Do not leave any antenna connectors unterminated. All connectors on the AP must be terminated with antennas or with 50 ohm Reverse Polarity SMA terminators. (For a list of approved terminators, see <http://www.merunetworks.com/merusupport>.)

The attached antennas must be the same model; if you replace one antenna, replace them all.

Install the Access Point

AP832e ships several different mounting bracket components to allow for a variety of mounting options. You can mount an AP832e in the following ways:

- [Mount AP832e Horizontally on a Shelf](#)
- [Mount AP832e Vertically on a Wall](#)
- [Mount AP832e Below a Suspended Ceiling](#)
- [Mount AP832e on a Dropped Ceiling Bevel Tile](#)
- [Mount AP832e on an Interlude T-Bar](#)

- [Mount AP832e Above a Suspended Ceiling](#)

Mount AP832e Horizontally on a Shelf

When mounting an AP832e horizontally, simply place it on the desired surface and connect power and network cables.

Mount AP832e Vertically on a Wall

The AP832 ships with a metal bracket that can be used to mount it on a wall. This bracket is used in conjunction with the plastic 650-00232 15/16" T-Bar Adapter/Wall Mount bracket to easily lock the AP into place.

To mount an AP832e on a wall:

1. Place the metal bracket against the wall. It should be oriented such that the indicator text for wall-mounting is pointing upwards (see [Figure 2](#)).

Figure 2: AP832 Wall Bracket

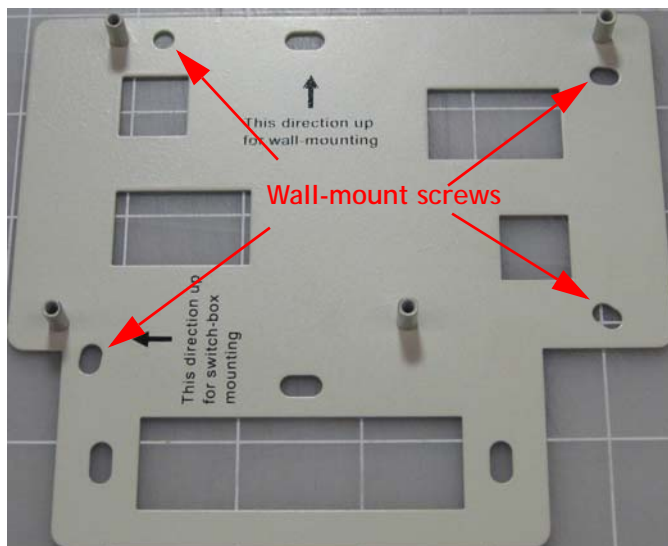

2. Attach the bracket to the wall using screws at the appropriate screw locations as indicated in [Figure 2](#). Recommend #6, #8 (M3, M3.5).
3. Locate the 650-00232 15/16" T-Bar Adapter/Wall Mount component and attach it to the raised screw locations on the Wall Mount plate. See [Figure 3](#).

Install the AP832e

Figure 3: Attaching the AP Mount to the Wall Mount

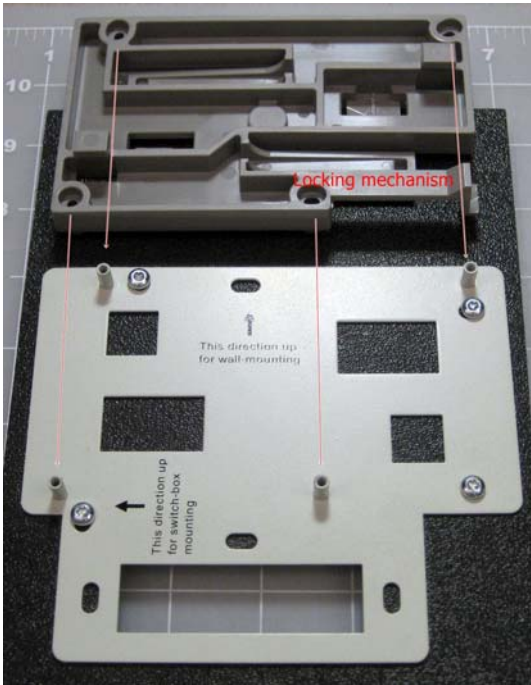

4. Screw the plastic component into place on the metal bracket.
5. Run the Ethernet and power cable (if using one) through the rectangular opening at the bottom of the Wall Mount bracket and connect them to their corresponding ports on the underside of the AP.
6. Press the Receiving Slots on the underside of the AP (indicated below) to the corresponding tabs ("Mounting Pins") on the plastic bracket. See [Figure 4](#).

Figure 4: Attaching the AP to the Wall Mount

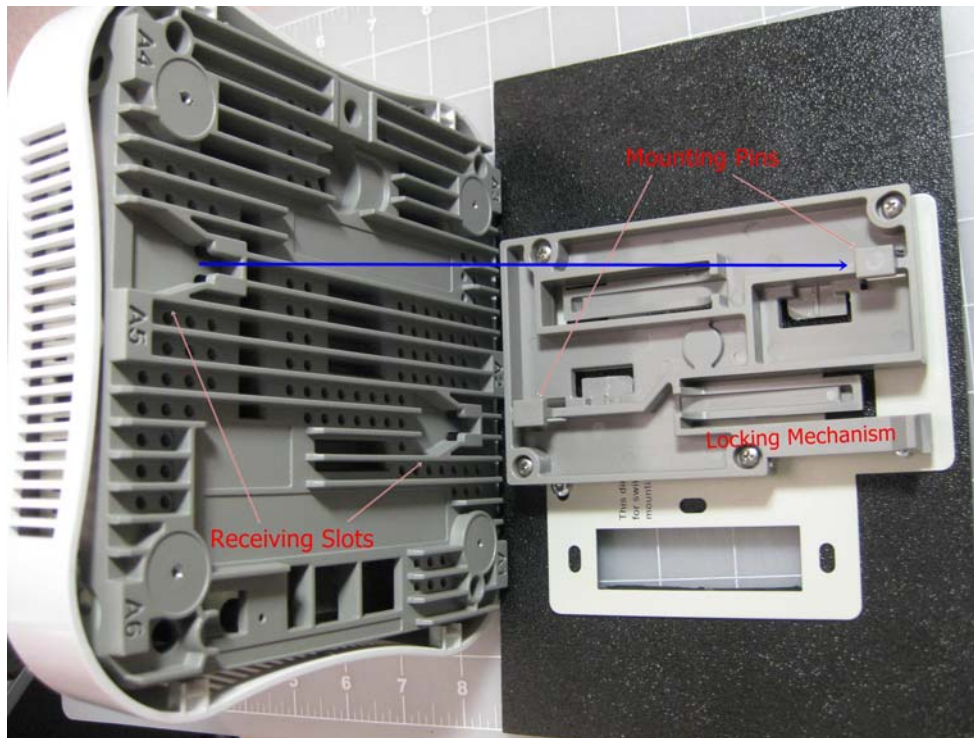

Note: Figure 4 shows an AP832i model being attached to the bracket, but the process is identical for either AP.

7. Slide the AP horizontally to lock the tabs into place.
8. If not already connected, you may now connect the Ethernet cable and DC power (if used) and verify that the AP comes online.

Mount AP832e Below a Suspended Ceiling

The provided ceiling mounting brackets allow the AP832e to attach to suspended ceiling T-rails. The AP ships with two different ceiling mounting bracket options to accommodate varying sizes of ceiling T-rails. Be sure to attach the correctly-sized bracket to your AP prior to attempting to deploy it. Note that each plastic bracket contains descriptive text to indicate the ceiling T-rail size for which it is designed.

To mount an AP832e below a suspended ceiling:

1. Determine the location on the ceiling rail where the AP will be mounted and remove the ceiling tiles.
2. Attach the AP to the mounting bracket by pressing the bracket's Mounting Pins (shown in Figure 4) to the AP's Receiving Slots and sliding the bracket until it locks in place.
3. Press the AP and bracket against the rail and twist to lock it into place.

Install the AP832e

4. Connect one end of the CAT5 (or greater) Ethernet cable with PoE to the 100/1000 Ethernet connector on the underside of the AP.
5. Verify that the AP comes online and then replace the ceiling tiles removed in Step 1.

Mount AP832e on a Dropped Ceiling Bevel Tile

The mounting procedure for a ceiling that has recessed supports and lowered tiles is similar to that of mounting on a suspended ceiling. However, this procedure requires a specialized mounting bracket (MNT-SCRMKIT-03), as shown in [Figure 5](#).

Figure 5: Dropped Bevel Tile Mounting Bracket

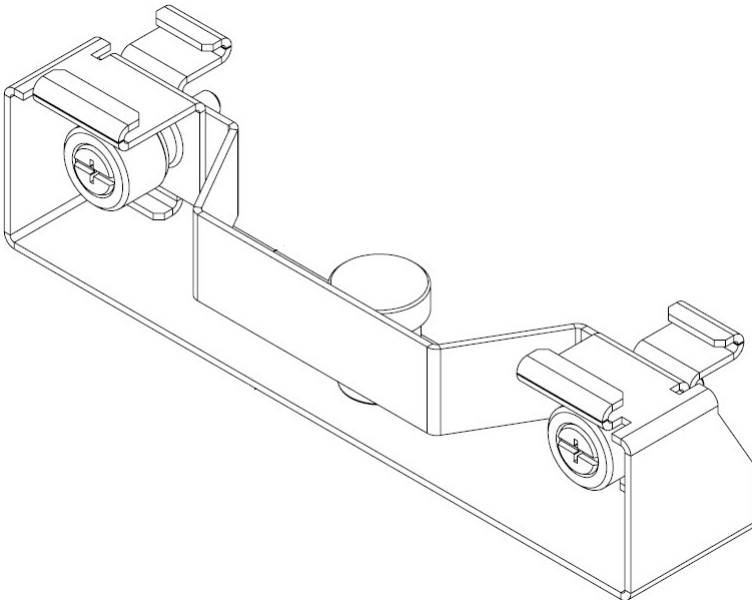

1. Remove the ceiling tile alongside which the AP will be mounted.
2. Locate the 650-00232 15/16" T-Bar Adapter/Wall Mount and attach the AP to the mounting bracket by pressing the bracket's Mounting Pins (shown in [Figure 4](#)) to the AP's Receiving Slots and sliding the bracket until it locks in place.
3. Push down on the thumbscrews provided on the mounting bracket and clip it to the ceiling bar that will support the AP.
4. Tighten the screws to ensure that the mechanism stays locked in place.
5. Gently press the underside of the AP (with bracket attached) against the Dropped Bevel Tile Mounting bracket indicated above and twist to lock them together.
6. Connect one end of the CAT5 (or greater) Ethernet cable with PoE to the 100/1000 Ethernet connector on the underside of the AP.
7. Verify that the AP comes online and then replace the ceiling tiles removed in Step 1.

Mount AP832e on an Interlude T-Bar

The mounting procedure for a ceiling that has interlude T-Bar supports is similar to that of mounting on a suspended ceiling. However, this procedure requires a specialized mounting bracket (MNT-SCRMKIT-04), as depicted in [Figure 6](#).

Figure 6: T-Bar Mounting Bracket

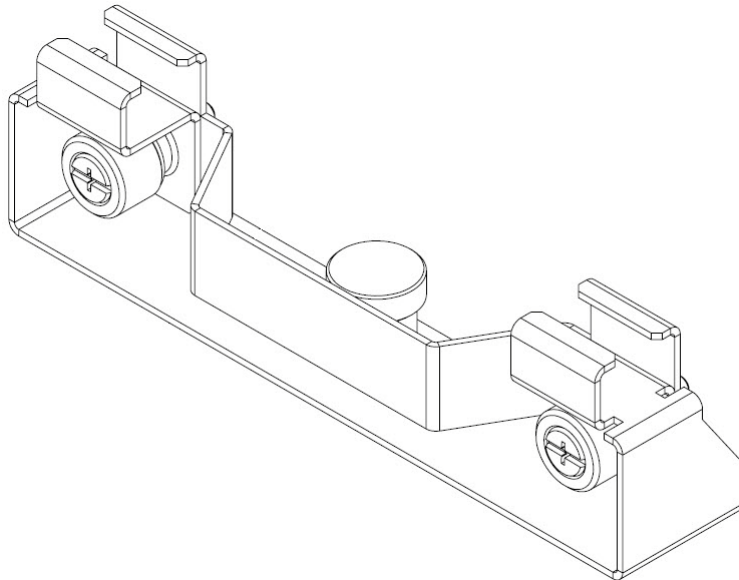

1. Remove the ceiling tile alongside which the AP will be mounted.
2. Locate the 650-00232 15/16" T-Bar Adapter/Wall Mount and attach the AP to the mounting bracket by pressing the bracket's Mounting Pins (shown in [Figure 4](#)) to the AP's Receiving Slots and sliding the bracket until it locks in place.
3. Push down on the thumbscrews provided on the mounting bracket and clip it to the ceiling bar that will support the AP.
4. Tighten the screws to ensure that the mechanism stays locked in place.
5. Gently press the underside of the AP (with bracket attached) against the T-Bar Mounting bracket indicated above and twist to lock them together.
6. Connect one end of the CAT5 (or greater) Ethernet cable with PoE to the 100/1000 Ethernet connector on the underside of the AP.
7. Verify that the AP comes online and then replace the ceiling tiles removed in Step 1.

Mount AP832e Above a Suspended Ceiling



Note:

AP832e is not plenum-rated and should only be mounted above ceilings in non-plenum air space, such as a return airflow for air conditioning.

Install the AP832e

Use the optional T-bar box hanger mounting kit to mount AP832e above suspended ceiling T-rails. The installation attaches the T-bar box hanger to the ceiling rails and then the AP832e attaches to the T-bar box hanger. Note that AP832e mounted above the ceiling has about 2-3 dBm less RF coverage than AP832e mounted under the ceiling.

You may need to modify thicker tiles to support this installation.



Warning! When installed in air-handling spaces, such as above a suspended ceiling, power the AP832e only with a PoE, not a power supply.

To mount an AP832e above the ceiling with the optional T-bar kit, follow these steps:

1. Determine the location on the ceiling rails where the AP will be mounted and remove the ceiling tile.
2. Unpack the T-bar hanger kit.
3. Attach the mounting bar (depicted in [Figure 7](#)) to the mounting brace (which looks like a small handle) with the crossbar of the mounting kit sandwiched between them. See [Figure 8](#).

Figure 7: Mounting Bar



Figure 8: Assembled Mounting Bracket

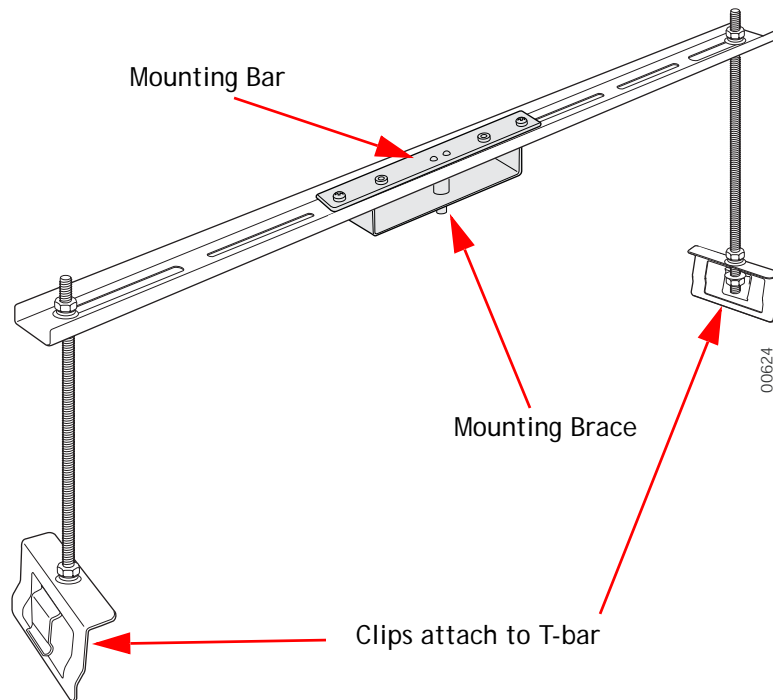

4. Locate the 650-00232 15/16" T-Bar Adapter/Wall Mount and attach the AP to the mounting bracket by pressing the bracket's Mounting Pins (shown in [Figure 4](#)) to the AP's Receiving Slots and sliding the bracket until it locks in place.
5. Gently press the underside of the AP against the mounting brace and rotate it into place until the locking mechanism clicks.
6. Attach the legs for the mounting kit to the T-Bars in the ceiling by sliding the clips down onto each respective bar.
7. Remove the top nut from each leg.
8. Lower the crossbar (with the AP attached) onto the legs and screw the nuts back on top of the bar.
9. Connect one end of the PoE Ethernet cable to the Ethernet connector on the AP.

**Note:**

Use a shielded Cat 5e (or greater) Ethernet cable in order to comply with international electromagnetic emissions limits.

Check that the AP832e is operating correctly before replacing the ceiling tile to the ceiling. Verify correct operation using the LEDs, as shown in [Check AP832e LED Activity](#).

Check AP832e LED Activity

When AP832e first connects to the controller (and any time the access point is rebooted), the AP initializes and then is programmed by the controller. When the AP first powers up, the LED is green. Thereafter, its color indicates its operating status.

Figure 9: AP832e Status LED

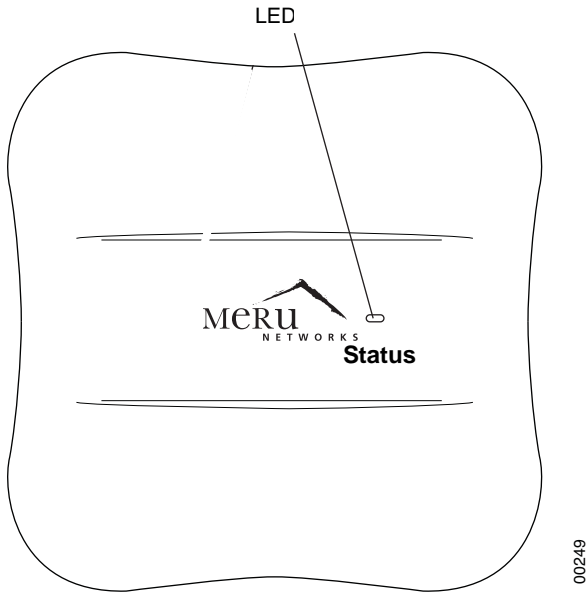

After the AP832e is connected, check the status of the LED. Its indicator state is described below.

AP832e LED Description

LED	Color	State:
Status	off	AP is off - either there is no power or the LEDs are set to Off on the controller. Check the LED setting on the controller by clicking Configuration > Devices > AP , selecting the AP and then checking the setting for LED Mode.
	cyan	AP is booting stage 1.
	green blinking	AP is booting stage 2.
	green/white alternating	AP is discovering the controller.
	green/blue alternating	AP is downloading a configuration from the controller.
	slow blue blinking	AP is online and enabled.
	rapid blue blinking	AP is online and enabled and there is activity on one or both radios.
	red/yellow alternating	Some AP failure occurred; check the controller for more details about the alarm by clicking Monitor > Alarms > Pending Alarms .
	blue/yellow alternating	AP is online and enabled and one or both radios are either scanning or an admin has taken the radio(s) down.

Change LED Appearance

If you want to change the appearance of the LEDs, follow these steps:

1. From the controller, click **Configuration > Devices > AP**, and then select the AP.
2. Select one of these settings for the LED Mode setting:
 - **Normal:** LEDs are as described above
 - **Blink:** Sets all LEDs flashing; this is useful to locate an AP
 - **Dark:** Turns off all LEDs
3. Click **OK**.

Where to Go From Here

Now that the AP832e is installed, go to the *Meru System Director Getting Started Guide* for instructions on initializing the hardware. Return to this chapter to check the status of the LEDs once the WLAN is operational.

Chapter 3

Installing AP832i

AP832i is supported by System Director versions 5.3 and greater. This chapter describes how to install and configure an AP832i. It contains the following sections:

- [Safety Precautions](#)
- [Unpack the AP832i](#)
- [Installing AP832i](#)
- [Check AP832i LED Activity](#)
- [Where to Go From Here](#)

Safety Precautions

IMPORTANT—Read and follow the regulatory instructions in Appendix B before installing and operating this product.

If an optional power supply is used, it must be one supplied by Meru Networks.



Warning!

This product is intended to be supplied by a UL Listed power supply marked Class 2 or LPS and rated minimum 12Vdc, 2A. For Power over Ethernet, an 802.3af or 802.3at connection must be used.

The AP832i is only intended for installation in Environment A as defined in IEEE 802.3af. All interconnected equipment must be contained within the same building, including the interconnected equipment's associated LAN connection.

Unpack the AP832i

Confirm that the shipping box contains the following:

- AP832i
- Wall mount bracket
- Two ceiling mount brackets (for varying sized ceiling structures)
- Screws for the mounting bracket
- 12V power adapter

Additional Equipment

A power source is needed to power the AP832i. The AP832i requires an 802.3af or 802.3at power source when operating with PoE. If this is not available, 12V DC power (2A rated) must be supplied.

Installing AP832i

Select a Location

All AP832i interconnected equipment must be contained within the same building, including the interconnected equipment's associated LAN connection. Ceiling mounting is recommended but wall mounting is also supported. In addition, the AP832i should be mounted in a location that meets the following conditions:

- Relatively unobstructed access to the stations the AP serves. Select a location with minimal physical obstructions between the AP and the wireless stations. In an office with cubicles, mounting the APs below a hanging ceiling (plenum is supported) or the wall near the ceiling provides the least obstructed communications path. On a wall, orient the AP832i horizontally so that you can read the Meru logo without tilting your head at 90 degrees - this orientation provides optimum MIMO performance.
- We recommend planning for about 50 clients per radio (or per interference region) if you plan to use Virtual Port and plan to have phones as clients. For a data-only installation, plan up to 128 clients per radio, meaning 256 for AP832i. Refer to the Meru Deployment Guides on the support site for more information.
- Access to wall outlet or a to a Power over Ethernet (PoE) connection to the network switch servicing the controller.

AP832i is designed to provide 180 degree omni-directional coverage as illustrated below. Plan placement with this pattern in mind.

Figure 10: Coverage Pattern for AP832i When Ceiling Mounted

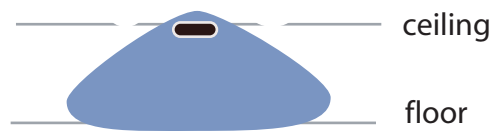

Most installations receive the best coverage using the following guidelines:

- Install APs toward the center of the building.
- Place APs about 80 feet apart.
- Do not install APs near metal objects, such as heating ducts, metal doors, or electric service panels.
- If you install AP832i on a pole, keep in mind that coverage will be 180 degrees. Do not mount two AP832is back to back on a pole to achieve 360 degree coverage, however, because the two units could interfere with each other.



Note: When planning to operating multiple radios on the same band (i.e., 2 radios on the 2.4GHz band), it is important that the user reduce the transmit power for each radio by 3dBm from its default setting.

Install the Access Point

AP832i ships several different mounting bracket components to allow for a variety of mounting options. You can mount an AP832i in the following ways:

- [Mount AP832i Horizontally on a Shelf](#)
- [Mount AP832i Vertically on a Wall](#)
- [Mount AP832i Below a Suspended Ceiling](#)
- [Mount AP832i on a Dropped Ceiling Bevel Tile](#)
- [Mount AP832i on an Interlude T-Bar](#)
- [Mount AP832i Above a Suspended Ceiling](#)

Mount AP832i Horizontally on a Shelf

When mounting an AP832i horizontally, simply place it on the desired surface and connect power and network cables.

Mount AP832i Vertically on a Wall

The AP832i ships with a metal bracket that can be used to mount it on a wall. This bracket is used in conjunction with the plastic 650-00232 15/16" T-Bar Adapter/Wall Mount bracket to easily lock the AP into place.

To mount an AP832i on a wall:

1. Place the metal bracket against the wall. It should be oriented such that the indicator text for wall-mounting is pointing upwards (see [Figure 11](#)).

Figure 11: AP832 Wall Bracket

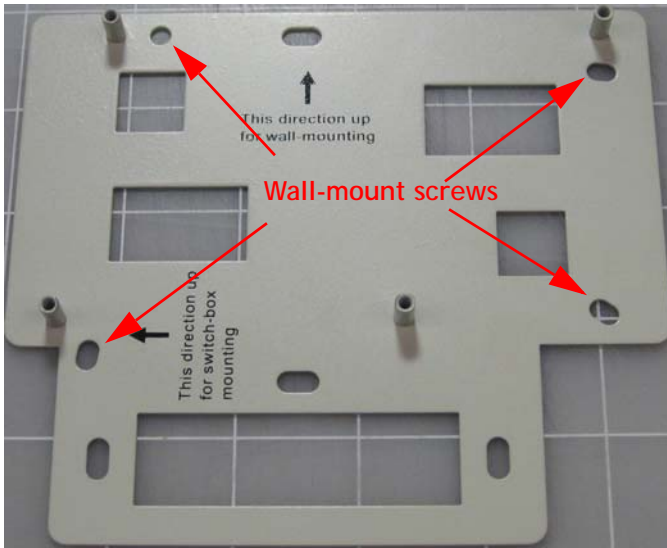

2. Attach the bracket to the wall using screws at the appropriate screw locations as indicated in [Figure 11](#). Recommend #6, #8 (M3, M3.5).
3. Locate the 650-00232 15/16" T-Bar Adapter/Wall Mount component and attach it to the raised screw locations on the Wall Mount plate. See [Figure 12](#).

Figure 12: Attaching the AP Mount to the Wall Mount

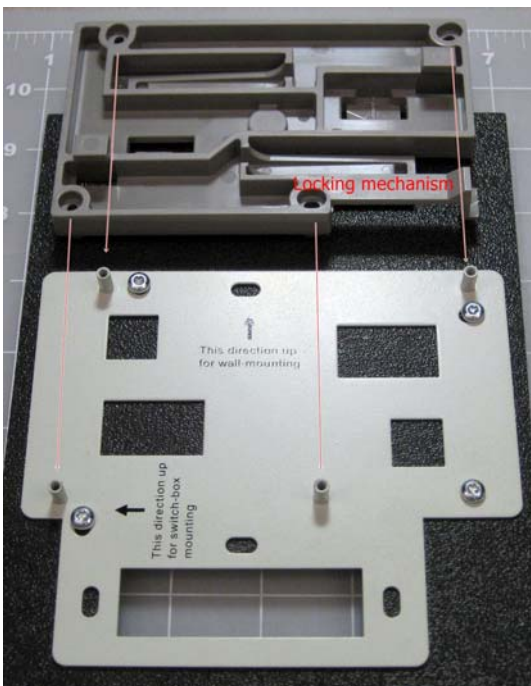

4. Screw the plastic component into place on the metal bracket.

5. Run the Ethernet and power cable (if using one) through the rectangular opening at the bottom of the Wall Mount bracket and connect them to their corresponding ports on the underside of the AP.
6. Press the Receiving Slots on the underside of the AP (indicated below) to the corresponding tabs ("Mounting Pins") on the plastic bracket. See [Figure 13](#).

Figure 13: Attaching the AP to the Wall Mount

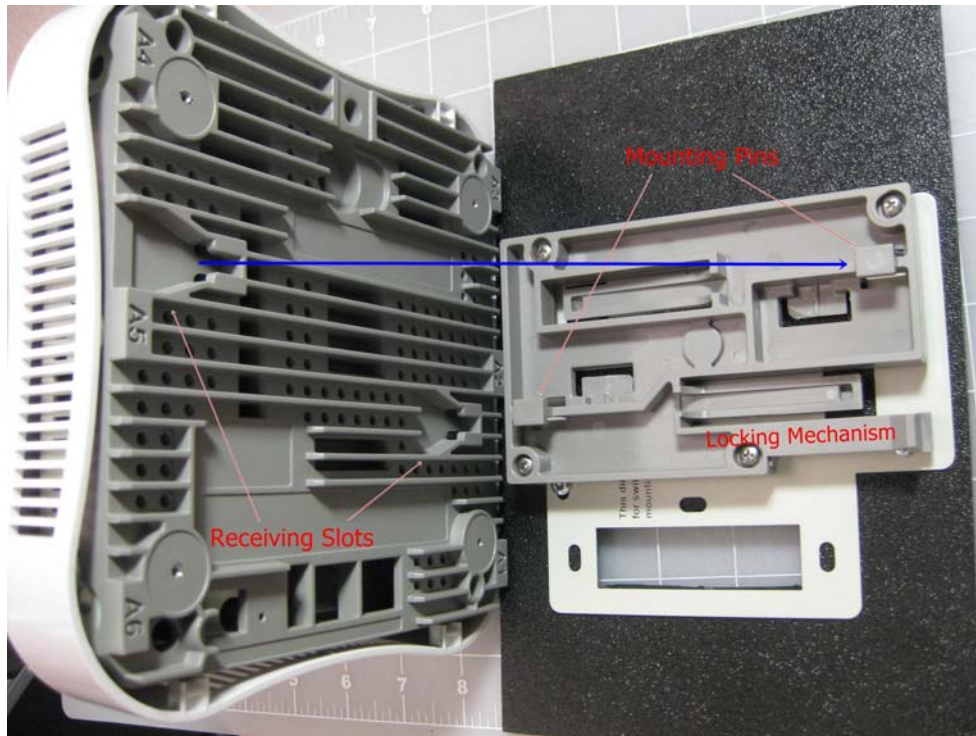

7. Slide the AP horizontally to lock the tabs into place.
8. If not already connected, you may now connect the Ethernet cable and DC power (if used) and verify that the AP comes online.

Mount AP832i Below a Suspended Ceiling

The provided ceiling mounting brackets allow the AP832i to attach to suspended ceiling T-rails. The AP ships with two different ceiling mounting bracket options to accommodate varying sizes of ceiling T-rails. Be sure to attach the correctly-sized bracket to your AP prior to attempting to deploy it. Note that each plastic bracket contains descriptive text to indicate the ceiling T-rail size for which it is designed.

To mount an AP832i below a suspended ceiling:

1. Determine the location on the ceiling rail where the AP will be mounted and remove the ceiling tiles.
2. Attach the AP to the mounting bracket by pressing the bracket's Mounting Pins (shown in [Figure 13](#)) to the AP's Receiving Slots and sliding the bracket until it locks in place.
3. Press the AP and bracket against the rail and twist to lock it into place.

4. Connect one end of the CAT5 (or greater) Ethernet cable with PoE to the 100/1000 Ethernet connector on the underside of the AP.
5. Verify that the AP comes online and then replace the ceiling tiles removed in Step 1.

Mount AP832i on a Dropped Ceiling Bevel Tile

The mounting procedure for a ceiling that has recessed supports and lowered tiles is similar to that of mounting on a suspended ceiling. However, this procedure requires a specialized mounting bracket (MNT-SCRMKIT-03), as shown in [Figure 14](#).

Figure 14: Dropped Bevel Tile Mounting Bracket

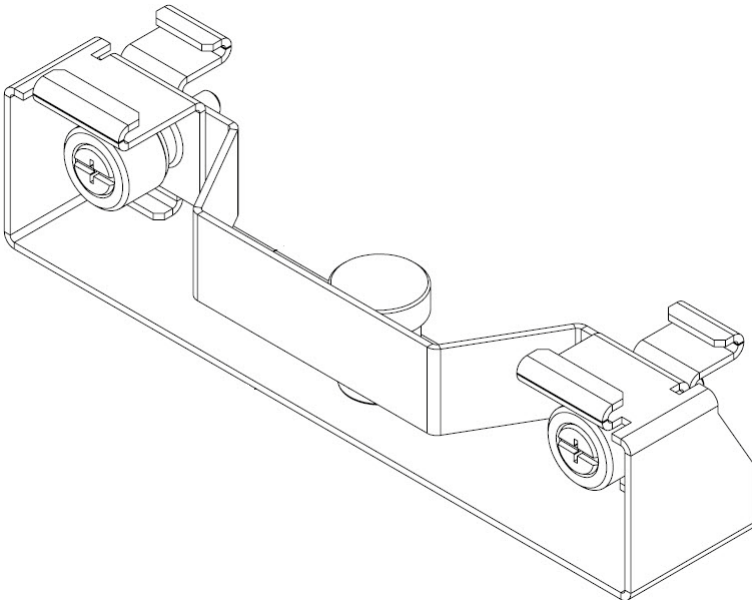

1. Remove the ceiling tile alongside which the AP will be mounted.
2. Locate the 650-00232 15/16" T-Bar Adapter/Wall Mount and attach the AP to the mounting bracket by pressing the bracket's Mounting Pins (shown in [Figure 13](#)) to the AP's Receiving Slots and sliding the bracket until it locks in place.
3. Push down on the thumbscrews provided on the mounting bracket and clip it to the ceiling bar that will support the AP.
4. Tighten the screws to ensure that the mechanism stays locked in place.
5. Gently press the underside of the AP (with bracket attached) against the Dropped Bevel Tile Mounting bracket indicated above and twist to lock them together.
6. Connect one end of the CAT5 (or greater) Ethernet cable with PoE to the 100/1000 Ethernet connector on the underside of the AP.
7. Verify that the AP comes online and then replace the ceiling tiles removed in Step 1.

Mount AP832i on an Interlude T-Bar

The mounting procedure for a ceiling that has interlude T-Bar supports is similar to that of mounting on a suspended ceiling. However, this procedure requires a specialized mounting bracket (MNT-SCRMKIT-04), as depicted in [Figure 15](#).

Figure 15: T-Bar Mounting Bracket

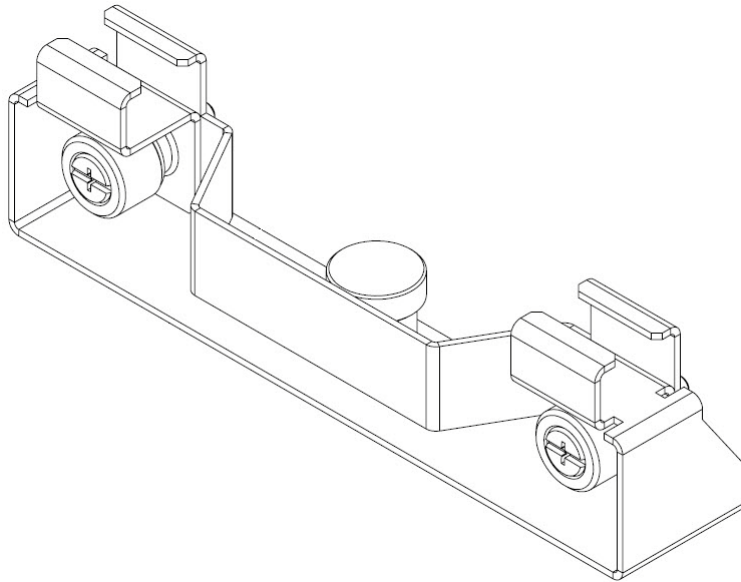

1. Remove the ceiling tile alongside which the AP will be mounted.
2. Locate the 650-00232 15/16" T-Bar Adapter/Wall Mount and attach the AP to the mounting bracket by pressing the bracket's Mounting Pins (shown in [Figure 13](#)) to the AP's Receiving Slots and sliding the bracket until it locks in place.
3. Push down on the thumbscrews provided on the mounting bracket and clip it to the ceiling bar that will support the AP.
4. Tighten the screws to ensure that the mechanism stays locked in place.
5. Gently press the underside of the AP (with bracket attached) against the T-Bar Mounting bracket indicated above and twist to lock them together.
6. Connect one end of the CAT5 (or greater) Ethernet cable with PoE to the 100/1000 Ethernet connector on the underside of the AP.
7. Verify that the AP comes online and then replace the ceiling tiles removed in Step 1.

Mount AP832i Above a Suspended Ceiling



Note:

AP832i is not plenum-rated and should only be mounted above ceilings in non-plenum air space, such as a return airflow for air conditioning.

Use the optional T-bar box hanger mounting kit to mount AP832i above suspended ceiling T-rails. The installation attaches the T-bar box hanger to the ceiling rails and then the AP832i attaches to the T-bar box hanger. Note that AP832i mounted above the ceiling has about 2-3 dBm less RF coverage than AP832i mounted under the ceiling.

You may need to modify thicker tiles to support this installation.



Warning! When installed in air-handling spaces, such as above a suspended ceiling, power the AP832i only with a PoE, not a power supply.

To mount an AP832i above the ceiling with the optional T-bar kit, follow these steps:

1. Determine the location on the ceiling rails where the AP will be mounted and remove the ceiling tile.
2. Unpack the T-bar hanger kit.
3. Attach the mounting bar (depicted in [Figure 16](#)) to the mounting brace (which looks like a small handle) with the crossbar of the mounting kit sandwiched between them. See [Figure 17](#).

Figure 16: Mounting Bar



Figure 17: Assembled Mounting Bracket

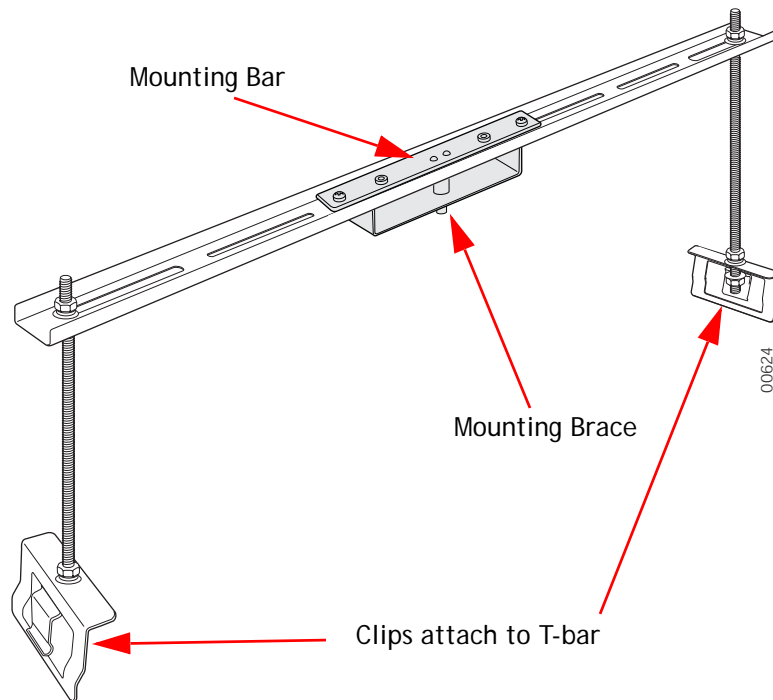

4. Locate the 650-00232 15/16" T-Bar Adapter/Wall Mount and attach the AP to the mounting bracket by pressing the bracket's Mounting Pins (shown in [Figure 13](#)) to the AP's Receiving Slots and sliding the bracket until it locks in place.
5. Gently press the underside of the AP against the mounting brace and rotate it into place until the locking mechanism clicks.
6. Attach the legs for the mounting kit to the T-Bars in the ceiling by sliding the clips down onto each respective bar.
7. Remove the top nut from each leg.
8. Lower the crossbar (with the AP attached) onto the legs and screw the nuts back on top of the bar.
9. Connect one end of the PoE Ethernet cable to the Ethernet connector on the AP.

**Note:**

Use a shielded Cat 5e (or greater) Ethernet cable in order to comply with international electromagnetic emissions limits.

Check that the AP832i is operating correctly before replacing the ceiling tile to the ceiling. Verify correct operation using the LEDs, as shown in [Check AP832i LED Activity](#).

Check AP832i LED Activity

When AP832i first connects to the controller (and any time the access point is rebooted), the AP initializes and then is programmed by the controller. When the AP first powers up, the LED is green. Thereafter, its color indicates its operating status.

Figure 18: AP832i Status LED

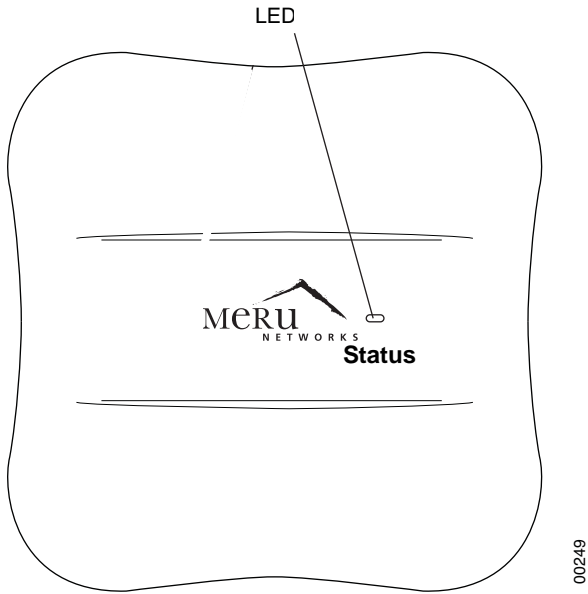

After the AP832i is connected, check the status of the LED. Its indicator state is described below.

AP832i LED Description

LED	Color	State:
Status	off	AP is off - either there is no power or the LEDs are set to Off on the controller. Check the LED setting on the controller by clicking Configuration > Devices > AP , selecting the AP and then checking the setting for LED Mode.
	cyan	AP is booting stage 1.
	green blinking	AP is booting stage 2.
	green/white alternating	AP is discovering the controller.
	green/blue alternating	AP is downloading a configuration from the controller.
	slow blue blinking	AP is online and enabled.
	rapid blue blinking	AP is online and enabled and there is activity on one or both radios.
	red/yellow alternating	Some AP failure occurred; check the controller for more details about the alarm by clicking Monitor > Alarms > Pending Alarms .
	blue/yellow alternating	AP is online and enabled and one or both radios are either scanning or an admin has taken the radio(s) down.

Change LED Appearance

If you want to change the appearance of the LEDs, follow these steps:

1. From the controller, click **Configuration > Devices > AP**, and then select the AP.
2. Select one of these settings for the LED Mode setting:
 - **Normal**: LEDs are as described above
 - **Blink**: Sets all LEDs flashing; this is useful to locate an AP
 - **Dark**: Turns off all LEDs
3. Click **OK**.

Where to Go From Here

Now that the AP832i is installed, go to the *Meru System Director Getting Started Guide* for instructions on initializing the hardware. Return to this chapter to check the status of the LEDs once the WLAN is operational.

Appendix A

Cautions and Warnings

The cautions and warnings that appear in this manual are listed below in English, German, French, and Spanish. Changes or modifications not expressly approved by the party responsible for compliance could void the user's authority to operate the equipment.

Cautions

A Caution calls your attention to a possible hazard that can damage equipment.

"Vorsicht" weist auf die Gefahr einer möglichen Beschädigung des Gerätes in.

Une mise en garde attire votre attention sur un risque possible d'endommagement de l'équipement. Ci-dessous, vous trouverez les mises en garde utilisées dans ce manuel.

Un mensaje de precaución le advierte sobre un posible peligro que pueda dañar el equipo. Las siguientes son precauciones utilizadas en este manual.



Caution! When changing the orientation of the antennas, be sure to slightly loosen the knurled ring before moving the antenna. Retighten the ring afterward. Otherwise, you might damage the internal cabling in the AP.

Vorsicht! Bei einer Neuausrichtung der Antennen muss vor Bewegung der Antenne der Rändelring leicht gelockert werden. Anschließend den Ring wieder festziehen. Anderenfalls können die internen Kabel im AP beschädigt werden.

Mise en garde En cas de modification d'orientation des antennes, veiller à desserrer légèrement la bague moletée avant de réorienter l'antenne. Resserrer ensuite la bague, faute de quoi le câblage interne du point d'accès pourrait être endommagé.

Precaución! Al cambiar la orientación de las antenas, asegúrese de aflojar ligeramente el anillo estriado antes de mover la antena. Luego vuelva a apretar el anillo. De otro modo, podría dañar el cableado interno del punto de acceso.



Caution! Be sure to connect the Ethernet cable to the Ethernet port; the cable can mistakenly be plugged into the Console port.

Vorsicht! Darauf achten, dass das Ethernetkabel am Ethernetanschluss und nicht versehentlich am Konsolenanschluss angeschlossen wird.

Mise en garde Veiller à bien connecter le câble Ethernet au port Ethernet et non pas au port Console.

Precaución! Asegúrese de conectar el cable Ethernet al puerto Ethernet, porque por error se puede enchufar en el puerto de la consola.



Caution! The radiated output power of the access points is well below the FCC radio frequency exposure limits. However, the Meru Access Point should be used in such a manner that the potential for human contact during normal operation is minimized. To avoid the possibility of exceeding the FCC radio frequency exposure limits, you should keep a distance of at least 20 cm between you (or any other person in the vicinity) and the Access Point antennas.

Vorsicht! Die abgestrahlte Ausgangsleistung von Geräten von Meru Networks, Inc. liegt weit unter den Hochfrequenz-Expositionsgrenzwerten der FCC. Die Meru Access Point Zugangspunkte von Meru Networks, Inc. sollten jedoch so verwendet werden, dass das Potenzial für Kontakt mit Menschen während des normalen Betriebs auf ein Mindestmaß beschränkt wird. Um die Möglichkeit einer Überschreitung der FCC-Hochfrequenz-Expositionsgrenzwerte zu vermeiden, ist ein Abstand von mindestens 20 cm zwischen Ihnen (bzw. einer anderen Person in der Nähe) und den Zugangspunkt-Antennen zu wahren.

Mise en garde La puissance de rayonnement émise par les équipements Meru Networks, Inc. est très inférieure aux limites d'exposition aux fréquences radio définies par la FCC. Toutefois, les points d'accès de la série Meru Access Point de Meru Networks, Inc. doivent être utilisés de façon à éliminer tout risque de contact humain en fonctionnement normal. Pour éviter de dépasser les limites d'exposition aux fréquences radio définies par la FCC, il est impératif de préserver en permanence une distance supérieure ou égale à 20 cm entre l'utilisateur (ou toute personne se trouvant à proximité) et les antennes du point d'accès.

Precaución! La potencia de radiación de los dispositivos de Meru Networks, Inc. está muy por debajo de los límites de exposición a radiofrecuencia estipulados por la FCC. No obstante, los puntos de acceso de la serie Meru Access Point de Meru Networks, Inc. deben usarse de tal manera que se minimice la posibilidad de contacto para el usuario durante la operación normal. Para evitar la posibilidad de exceder los límites de exposición a radiofrecuencia establecidos por la FCC, el usuario (o cualquier otra persona en torno) debe mantenerse a una distancia de al menos 20 cm respecto a las antenas del punto de acceso.



Caution! Exposure to Radio Frequency Radiation.

The installer of this radio equipment must ensure that the antenna is located or pointed such that it does not emit an RF field in excess of Health Canada limits for the general population; consult Safety Code 6, obtainable from Health Canada's website <http://www.hc-sc.gc.ca/rpb>.

Vorsicht! Exposure to Radio Frequency Radiation.

The installer of this radio equipment must ensure that the antenna is located or pointed such that it does not emit an RF field in excess of Health Canada limits for the general population; consult Safety Code 6, obtainable from Health Canada's website <http://www.hc-sc.gc.ca/rpb>.

Mise en garde Exposition aux rayonnements à fréquence radioélectrique

L'installateur de cet équipement radio doit veiller à positionner et orienter l'antenne de telle sorte qu'elle n'émette pas un champ radioélectrique supérieur aux limites définies par Santé Canada pour la population générale. Consulter le Code de sécurité n° 6, disponible sur le site Web de Santé Canada à l'adresse <http://www.hc-sc.gc.ca/rpb>.

Precaución! Exposición a la radiación de radiofrecuencia.

El instalador de este equipo de radio debe cerciorarse de que la antena está localizada u orientada de tal manera que no emita un campo de radiofrecuencia superior a los límites estipulados por Health Canada para la población; consulte el Código de Seguridad 6 que podrá encontrar en el página web de Health Canada, <http://www.hc-sc.gc.ca/rpb>.

Warnings

A warning calls your attention to a possible hazard that can cause injury or death. The following are the warnings used in this manual.

"Achtung" weist auf eine mögliche Gefährdung hin, die zu Verletzungen oder Tod führen können. Sie finden die folgenden Warnhinweise in diesem Handbuch:

Un avertissement attire votre attention sur un risque possible de blessure ou de décès. Ci-dessous, vous trouverez les avertissements utilisés dans ce manuel.

Una advertencia le llama la atención sobre cualquier posible peligro que pueda ocasionar daños personales o la muerte. A continuación se dan las advertencias utilizadas en este manual.



Warning! With plastic covers removed, this product is suitable for use in environmental air space in accordance with the Section 300-22(c) of the National Electric Code and Sections 2- 128.12 - 010 (3) and 12 - 100 of the Canadian Electrical Code. Part 1. C22. 1. For other countries, consult local authorities for regulations.

Achtung! Bei abgenommener Kunststoffabdeckung ist dieses Produkt zur Verwendung in einem Umgebungsluftraum gemäß Abschnitt 300-22(c) des National Electric Code und Abschnitt 2- 128.12 - 010 (3) und 12 - 100 des Canadian Electrical Code Teil 1. C22.1 geeignet. Die Vorschriften für andere Länder sind bei den örtlichen Behörden erhältlich.

Avertissement Sous réserve que ses couvercles de plastique soient déposés, cet appareil est adapté à une utilisation dans les vides de construction des bâtiments selon la section 300-22(c) du code NEC (National Electric Code) et les sections 2- 128.12 - 010 (3) et 12 - 100 du Code électrique du Canada, partie 1. C22. 1. Pour tous les autres pays, consulter les organismes de réglementation locaux.

Advertencia Una vez desprendidas las cubiertas de plástico, este producto es adecuado para su uso en el espacio aéreo circundante en conformidad con la sección 300-22(c) del National Electric Code (Código Eléctrico Nacional de EE.UU.) y las secciones 2- 128.12 - 010 (3) y 12 - 100 del Código Eléctrico de Canadá. Parte 1. C22. 1. En otros países, consulte a las autoridades locales competentes para informarse acerca de las normativas vigentes.



Warning! Any Fast Ethernet (FE) cables installed in air-handling spaces should be suitable under NEC Article 800.50 and marked accordingly for use in plenums and air-handling spaces with regard to smoke propagation, such as CL2-P, CL3-P, MPP (Multi Purpose Plenum), or CMP (Communications Plenum).

Achtung! Alle Fast-Ethernet (FE)-Kabel, die in Lüftungsräumen installiert werden, sollten gemäß NEC Artikel 800.50 geeignet sein und entsprechend zur Verwendung in Hohlräumen (Plenum) und Lüftungsräumen im Hinblick auf Rauchausbreitung gekennzeichnet sein, z.B. CL2-P, CL3-P, MPP (Multi Purpose Plenum) oder CMP (Communications Plenum).

Avertissement Les câbles Fast Ethernet (FE) installés dans un vide d'air doivent correspondre aux critères de l'article 800.50 du code NEC et identifiés en conséquence comme adaptés à une utilisation dans les vides de construction des bâtiments en matière de propagation de la fumée (marquages CL2-P, CL3-P, MPP (Multi Purpose Plenum) ou CMP (Communications Plenum)).

Advertencia Todos los cables Fast Ethernet (FE) instalados en espacios aéreos deben cumplir con el artículo 800.50 del NEC y estar marcados adecuadamente para su uso en espacios aéreos y plenums en lo concerniente a la propagación de humo, tales como CL2-P, CL3-P, MPP (Plenum multifuncional), o CMP (Plenum de comunicaciones).



Warning! Inside antennas must be positioned to observe minimum separation of 20 cm. (~ 8 in.) from all users and bystanders. For the protection of personnel working in the vicinity of inside (downlink) antennas, the following guidelines for minimum distances between the human body and the antenna must be observed.

The installation of the indoor antenna must be such that, under normal conditions, all personnel cannot come within 20 cm. (~ 8.0 in.) from any inside antenna. Exceeding this minimum separation will ensure that the employee or bystander does not receive RF-exposure beyond the Maximum Permissible Exposure according to FCC CFR 47, section 1.1310 i.e. limits for General Population/Uncontrolled Exposure.

Achtung! Innenantennen müssen so positioniert werden, dass ein Mindestabstand von 20 cm (ca. 8 Zoll) zu allen Benutzern und anderen Personen gewahrt wird. Zum Schutz von Personal, das in der Nähe von Innenantennen (Downlink) arbeitet, sind die folgenden Richtlinien für Mindestabstand zwischen dem menschlichen Körper und der Antenne zu beachten.

Die Innenantenne muss so installiert werden, dass sich unter normalen Bedingungen kein Personal bis auf weniger als 20 cm (ca. 8 Zoll) an eine Innenantenne annähern kann. Durch Überschreitung dieses Mindestabstands wird sichergestellt, dass Mitarbeiter oder andere Personen keiner RF-Exposition über die maximal zulässige Exposition (MPE; Maximum Permissible Exposure) gemäß FCC CFR 47, Abschnitt 1.1310 (Grenzwerte für die allgemeine Bevölkerung/unkontrollierte Exposition) ausgesetzt werden.

Avertissement Les antennes intérieures doivent être positionnées de façon à respecter une distance minimum de 20 cm par rapport aux utilisateurs et aux tiers. Pour la protection du personnel travaillant à proximité des antennes intérieures (liaison descendante), respecter les directives suivantes pour assurer des distances minimales entre les êtres humains et les antennes.

Toute antenne intérieure doit être installée de telle sorte que, dans des conditions normales, le personnel ne puisse s'en approcher à moins de 20 cm. Cette distance minimale est destinée à garantir qu'un employé ou un tiers ne sera pas exposé à un rayonnement radioélectrique supérieur à la valeur maximale autorisée, telle qu'elle est définie dans les limites d'exposition non contrôlées pour la population par la réglementation de la FCC CFR 47, section 1.1310.

Advertencia Las antenas interiores deben colocarse de manera que se observe una separación mínima de 20 cm. (~ 8 pulg.) respecto a todos los usuarios y circunstantes. Para la protección del personal que trabaje en las inmediaciones de las antenas interiores (receptoras), deben observarse las siguientes directrices relativas a la distancia mínima entre el cuerpo humano y la antena.

La instalación de la antena interior debe efectuarse de tal modo que, en condiciones normales, ningún miembro del personal pueda acercarse a menos de 20 cm. (~ 8,0 pulg.) de cualquier antena interior. El cumplimiento de este mínimo de separación asegura que el empleado o circunstante no recibirá exposición a radiofrecuencia por encima de la Exposición Máxima Permisible conforme a la normativa FCC CFR 47, sección 1.1310, es decir, los límites asignados a la Exposición Incontrolada/Población Civil.

Warnings

Appendix B

Regulatory Information

The Meru Access Point (APs) must be installed and used in strict accordance with the manufacturer's instructions as described in the user documentation that comes with the product. For country-specific approvals, see below. Meru Networks, Inc. is not responsible for any radio or television interference caused by unauthorized modification of APs, or the substitution or attachment of connecting cables and equipment other than that specified by Meru Networks, Inc. The correction of interference caused by such unauthorized modification, substitution or attachment is the responsibility of the user. Meru Networks, Inc. and its authorized resellers or distributors are not liable for any damage or violation of government regulations that may arise from the user failing to comply with these guidelines.

Approved Antennas

Only approved antennas may be used in conjunction with AP832 access points. The following antennas are approved for use with the AP832 series.

Part Numbers		Manufacturer	Gain	Description
Meru	Manufacturer			
ANT-ABGN230-W		SOCAA	2/3	Dual-band omnidirectional dipole
ANT-ABGN230-W	S24493TS	Laird Technologies	3/4	Dual-band ceiling mount omnidirectional 3-lead
ANT-6ABGN-24	M6025040MO1D3620P	Terrawave	2.5/4 dBi	Dual-band ceiling mount omnidirectional 6-lead
ANT-ABGN470	ANT-DB1-RAF-RPS	Linx Technologies	4.7/4.7 dBi	Dual-band high gain dipole omnidirectional
ANT-O6ABGN-0606-O	M6060060MO1D3620O	Terrawave	6/6 dBi	Dual band omnidirectional 6-lead
ANT-I2ABGN-0304-O	M6030040O1D3620DP	Terrawave	3/4 dBi	Dual-band ceiling mount omnidirectional 2-lead

Part Numbers		Manufacturer	Gain	Description
ANT-I3ABGN-0304-O	M603004001D1820MP	Terrawave	3/4 dBi	Dual-band ceiling mount omnidirectional 3-lead
ANT-O4ABGN-0607-PT	M6060070P23620	Terrawave	6/7 dBi	Dual-band wall-mount patch 4-lead
ANT-O6ABGN-0607-PT	M6060070MP13620	Terrawave	6/7 dBi	Dual-band wall-mount patch 6-lead

Regulatory Specifications

Radio

- FCC Part 15
- Canada RSS210
- EN 300 328 V1.6.1 (11/2004)
- EN 301 893 V1.3.1 (08/2005)
- Japan Technical Regulations

EMC

- FCC Part 15
- EN 301 489-17 V1.2.1 (08/2002)
- Japan VCCI

Safety

Prolonged exposure to RF radiation can be hazardous. Switch off unit power before service or installation procedures.

Limits for Occupational/Controlled Exposure

Frequency Range (MHz)	Electric Field Strength (E) (V/m)	Magnetic Field Strength (H) (A/m)	Power Density (S) (mW/cm ²)	Averaging Time E ² , H ² or S (minutes)
1500-100,000			5	6

Limits for General Population/Uncontrolled Exposure

Frequency Range (MHz)	Electric Field Strength (E) (V/m)	Magnetic Field Strength (H) (A/m)	Power Density (S) (mW/cm ²)	Averaging Time E ² , H ² or S (minutes)
1500-100,000			1.0	30



Note:

Occupational/controlled limits apply in situations in which persons are exposed as a consequence of their employment provided those persons are fully aware of the potential for exposure and can exercise control over their exposure. Limits for occupational/controlled exposure also apply in situations when an individual is transient through a location where occupational/controlled limits apply provided he or she is made aware of the potential for exposure.



Note:

General population/uncontrolled exposures apply in situations in which the general public may be exposed, or in which persons that are exposed as a consequence of their employment may not be fully aware of the potential for exposure or can not exercise control over their exposure.

Frequencies Blocked for Regulatory Compliance

802.11a frequencies 5.25-5.35 GHz and 5.47-5.725 GHz have been blocked for DFS compliance.

AP832e/i

AP332	Toxic and Hazardous Substances or Elements					
Component with toxic and hazardous substances	Pb (Lead)	Hg (Mercury)	Cd (Cadmium)	Cr(VI) (Hexavalent Chrome)	PBB (Polybrominated biphenyl)	PBDE (Polybrominated diphenyl ether)
Circuit Modules	X	O	O	O	O	O
Metal Parts	O	O	O	O	O	O
Plastic and Polymeric Parts	O	O	O	O	O	O

O: Indicates that the content of the toxic and hazardous substance in all the homogenous materials of the part is below the concentration limit requirement for RoHS compliance.
X: Indicates that the content of the toxic and hazardous substance in at least one homogeneous material of the part exceeds the concentration limit requirement for RoHS compliance

USA

Underwriters Laboratories

Use only with Listed I.T.E. equipment.

Notices

The unit is intended for installation in Environment A as defined in IEEE 802.3.af. All interconnected equipment must be contained within the same building, including the interconnected equipment's associated LAN connection.

Suitable for use in environmental air space in accordance with Section 300-22(c) of the National Electrical Code, and Sections 2-128, 12-010(3) and 12-100 of the Canadian Electrical Code, Part 1, C22.1.

FCC Radiation Exposure Statement



Caution!

The radiated output power of the Meru Networks devices is well below the FCC radio frequency exposure limits. However, the Access Point should be used in such a manner that the potential for human contact during normal operation is minimized. When installing and operating these devices, keep a minimum distance of 20 cm (8 inches) between the antennas and any persons/users in the vicinity.

Radio Frequency Interference Requirements



Note:

Meru Access Points

All devices except the OAP180 are indoor devices. The FCC requires indoor use for the frequency range 5.15 GHz to 5.25 GHz to reduce the potential for harmful interference to co-channel Mobile Satellite systems.

High-power radars are allocated as primary users of the 5.25 to 5.35 GHz and 5.65 to 5.85 GHz bands. These radar stations can cause interference with or damage to these devices, or both.

Interference Statement

This device complies with Part 15 of the FCC Rules. Operation is subject to the following two conditions: (1) This device may not cause harmful interference, and (2) this device must accept any interference received, including interference that may cause undesired operation.

This equipment has been tested and found to comply with the limits for a Class B digital device, pursuant to Part 15 of the FCC Rules. These limits are designed to provide reasonable protection against harmful interference in a residential installation. This equipment generates, uses, and can radiate radio frequency energy. If the equipment is not installed and used in accordance with the instructions, the equipment may cause harmful interference to radio communications. There is no guarantee, however, that such interference will not occur in a particular installation. If this equipment does cause harmful interference to radio or television reception (which can be determined by turning the equipment off and on), the user is encouraged to try to correct the interference by taking one or more of the following measures:

- Reorient or relocate the receiving antenna.
- Increase the separation between the equipment and receiver.
- Connect the equipment into an outlet on a circuit different from to which the receiver is connected.
- Consult the dealer or an experienced radio/TV technician for help.



Note:

The Meru Access Point must be installed and used in strict accordance with the manufacturer's instructions as described in the user documentation that comes with the product. Any other installation or use may violate FCC Part 15 regulations. Modifications not expressly approved by Meru Networks, Inc. could void your authority to operate the equipment.

This device must not be co-located or operating in conjunction with any other antenna or transmitter.

For products available in the USA and Canadian markets, only channels 1 through 11 can be operated. Selection of other channels is not authorized.

Canada. Industry Canada (IC)

The Class B digital portion of this apparatus complies with Canadian standard ICES-003.

These devices comply with RSS210 of Industry Canada.

Per RSS 210 A9.5 point 7:

- (i) the device for the band 5150-5250 MHz is only for indoor usage to reduce potential for harmful interference to co-channel mobile satellite systems;
- (ii) the maximum antenna gain permitted (for devices in the bands 5250-5350 MHz and 5470-5725 MHz) to comply with the e.i.r.p. limit; and
- (iii) the maximum antenna gain permitted (for devices in the band 5725-5825 MHz) to comply with the e.i.r.p. limits specified for point-to-point and non point-to-point operation as appropriate, as stated in section A9.2(3).

In addition, users should also be cautioned to take note that high-power radars are allocated as

primary users (meaning they have priority) of the bands 5250-5350 MHz and 5650-5850 MHz and these radars could cause interference and/or damage to LE-LAN devices.
(iv) These devices are not permitted to operate in the 5600 - 5650 MHz band.

For products available in the USA and Canadian markets, only channels 1 through 11 can be operated. Selection of other channels is not authorized.

Operation is subject to the following two conditions: (1) this device may not cause interference, and (2) this device must accept any interference, including interference that may cause undesired operation of this device.

This device and its listed antenna(s) must not be co-located or operated in conjunction with any other antenna or transmitter

L'utilisation de ce dispositif est autorisée seulement aux conditions suivantes: (1) il ne doit pas produire de brouillage et (2) l'utilisateur du dispositif doit être prêt à accepter tout brouillage radioélectrique reçu, même si ce brouillage est susceptible de compromettre le fonctionnement du dispositif.

The term "IC" before the equipment certification number only signifies that the Industry Canada technical specifications were met.

To reduce the potential radio interference to other users, the antenna type and gain should be chosen so that the equivalent isotropically radiated power (EIRP) is not more than that required for successful communication.

To prevent radio interference to the licensed service, this device is intended to be operated indoors and away from windows to provide maximum shielding. Equipment (or its transmit antenna) that is installed outdoors is subject to licensing.

Pour empêcher que cet appareil cause du brouillage au service faisant l'objet d'une licence, il doit être utilisé à l'intérieur et devrait être placé loin des fenêtres afin de fournir un écran de blindage maximal. Si le matériel (ou son antenne d'émission) est installé à l'extérieur, il doit faire l'objet d'une licence.



Exposure to Radio Frequency Radiation.

Caution!

The installer of this radio equipment must ensure that the antenna is located or pointed such that it does not emit an RF field in excess of Health Canada limits for the general population; consult Safety Code 6, obtainable from Health Canada's website <http://www.hc-sc.gc.ca/rpb>.

This equipment complies with IC RSS-102 radiation exposure limits set forth for an uncontrolled environment. This equipment should be installed and operated with a minimum distance of 20cm between the antennas and any persons/users in the vicinity.



Meru Access Points

Note:

These devices are restricted to indoor use because they operate in the 5.15 to 5.25 GHz frequency range. Industry Canada requires such products to be used indoors for the frequency range 5.15 GHz to 5.25 GHz to reduce the potential for harmful interference to co-channel Mobile Satellite systems.

Access Points have been designed to operate with the antennas listed below. Antennas not included in this list are strictly prohibited for use with these devices. The required antenna impedance is 50 ohms.

AP Antennas with Gain

AP Model	Antenna Type	Gain (2.4 GHz)	Gain (5 GHz)
AP300	Dual-Band Omni-Directional MN-ANTabg-W	2 dBi	3 dBi
AP300	Dual-Band Omni-Directional ANT-ABGN-23	2 dBi	3 dBi
AP300	High-Gain Dipole Omni-Directional ANT-ABGN470	4.7dBi	4.7dBi

To reduce potential radio interference to other users, the antenna type and its gain should be chosen so that the equivalent isotropically radiated power (e.i.r.p.) is not more than that permitted for successful communication.

Europe—EU Declaration of Conformity and Restrictions



This equipment is marked with either the CE Mark, the alert symbol, and the notified body's number and can be used throughout the European Community. This mark indicates compliance with the R&TTE Directive 1999/5/EC and the relevant parts of the following technical specifications.

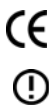

This equipment is marked with either the CE Mark, the alert symbol, and the notified body's number and can be used throughout the European Community. This mark indicates compliance with the R&TTE Directive 1999/5/EC and the relevant parts of the following technical specifications.

EN 300 328. Electromagnetic Compatibility and Radio Spectrum Matters (ERM). Wideband transmission systems, data transmission equipment operating in the 2.4 GHz ISM (Industrial, Scientific, and Medical frequency bands in the range of 902-928 MHz, 2.4-2.485 GHz, and 5.15-5.25 GHz) band and using spread spectrum modulation techniques, harmonized EN standards covering essential requirements under article 3.2 of the R&TTE directive.

EN 301 893. Broadband Radio Access Networks (BRAN). 5 GHz high-performance RLAN, harmonized EN standards covering essential requirements of article 3.2 of the R&TTE directive.

EN 301 489-17. Electromagnetic Compatibility and Radio Spectrum Matters (ERM). Electromagnetic Compatibility (EMC) Standard for Radio Equipment and Services, Part 17 Specific Conditions for Wideband Data and HIPERLAN Equipment.

EN 55022 Statement (applicable to AP201 Rev 2, AP208 Rev 2 only). This is to certify that the above models are shielded against the generation of radio interference in accordance with the application of Council Directive 2004/108/EC, Annex I, 1a. Conformity is declared by the application of EN 55 022 Class B (CISPR 22). Compliance is dependent upon the use of Cat 5e shielded data cables.

EN 60950-1. Safety of Information Technology Equipment.

EN 50385. Product standard to demonstrate the compliances of radio base stations and fixed terminal stations for wireless telecommunication systems with the basic restrictions or the reference levels related to human exposure to radio frequency electromagnetic fields.



Marking by the alert symbol indicates that usage restrictions apply.



Marking by the alert symbol indicates that usage restrictions apply.

Meru Networks, Inc. declares that their Access Points comply with the essential requirements and other relevant provisions of Directive 1999/5/EC.

Meru Networks, Inc. vakuuttaa täten että Access Points tyyppinen laite on direktiivin 1999/5/EY oleellisten vaatimusten ja sitä koskevien direktiivin muiden ehtojen mukainen.

Hierbij verklaart Meru Networks, Inc. dat het toestel Access Points in overeenstemming is met de essentiële eisen en de andere relevante bepalingen van richtlijn 1999/5/EG.

Bij deze verklaart Meru Networks, Inc. dat deze Access Points voldoet aan de essentiële eisen en aan de overige relevante bepalingen van Richtlijn 1999/5/EC.

Par la présente, Meru Networks, Inc. déclare que l'appareil Access Points est conforme aux exigences essentielles et aux autres dispositions pertinentes de la directive 1999/5/CE.

Par la présente, Meru Networks, Inc. déclare que ce Access Points est conforme aux exigences essentielles et aux autres dispositions de la directive 1999/5/CE qui lui sont applicables.

Härmed intygar Meru Networks, Inc. att denna Access Points står i överensstämmelse med de väsentliga egenskapskrav och övriga relevanta bestämmelser som framgår av direktiv 1999/5/EG.

Undertegnede Meru Networks, Inc. erklærer herved, at følgende udstyr Access Points overholder de væsentlige krav og øvrige relevante krav i direktiv 1999/5/EF.

Hiermit erklärt Meru Networks, Inc. dass sich dieser/diese/dieses Access Points in Übereinstimmung mit den grundlegenden Anforderungen und den anderen relevanten Vorschriften der Richtlinie 1999/5/EG befindet.

Hiermit erklärt Meru Networks, Inc. die Übereinstimmung des Gerätes Access Points mit den grundlegenden Anforderungen und den anderen relevanten Festlegungen der Richtlinie 1999/5/EG.

Con la presente Meru Networks, Inc. dichiara che questo Access Points è conforme ai requisiti essenziali ed alle altre disposizioni pertinenti stabilite dalla direttiva 1999/5/CE.

Por medio de la presente Meru Networks, Inc. declara que el Access Points cumple con los requisitos esenciales y cualesquiera otras disposiciones aplicables o exigibles de la Directiva 1999/5/CE.

Meru Networks, Inc. declara que este Access Points está conforme com os requisitos essenciais e outras disposições da Directiva 1999/5/CE.

Hawnhekk, Meru Networks, Inc. jiddikjara li dan Access Points jikkonforma mal-htigijiet essenzjali u ma provvedimenti ohrajn relevanti li hemm fid-Dirrettiva 1999/5/EC.

Käesolevaga kinnitab Meru Networks, Inc. seadme Access Points vastavust direktiivi 1999/5/EÜ põhinõuetele ja nimetatud direktiivist tulenevatele teistele asjakohastele sätetele.

Alulírott, Meru Networks, Inc. nyilatkozom, hogy a Access Points megfelel a vonatkozó alapvető követelményeknek és az 1999/5/EC irányelv egyéb előírásainak.

Meru Networks, Inc. týmto vyhlasuje, e Access Points splna základné poiadvky a všetky príslušné ustanovenia Smernice 1999/5/ES.

Meru Networks, Inc. tímto prohlašuje, e tento Access Points je ve shode se základními poiadvky a dalšími příslušnými ustanoveními smernice 1999/5/ES.

Šiuo Meru Networks, Inc. deklaruoja, kad šis Access Points atitinka esminius reikalavimus ir kitas 1999/5/EB Direktyvos nuostatas.

Ar šo Meru Networks, Inc. deklare, ka Access Points atbilst Direktivas 1999/5/EK butiskajam prasibam un citiem ar to saistitajiem noteikumiem.

Niniejszym, Meru Networks, Inc., deklaruje, ze Access Points spelnia wymagania zasadnicze oraz stosowne postanowienia zawarte Dyrektywie 1999/5/EC.

These products are intended to be used in all countries of the European Economic Area with the following restrictions:

IEEE 802.11a Restrictions

- These products are for indoor use only (5150-5250 MHz).
- To ensure compliance with local regulations, be sure to set your Access Point to the country in which you are using the Access Point.
- The Meru Access Point products can be used only indoors in the following countries: Austria, Belgium, Bulgaria, Czech Republic, Germany, Cyprus, Denmark, Estonia, Finland, France, Greece, Hungary, Iceland, Ireland, Italy, Latvia, Lithuania, Luxembourg, Malta, The Netherlands, Norway, Portugal, Poland, Romania, Spain, Slovak Republic, Slovenia, Sweden, Switzerland, Turkey, and United Kingdom.

IEEE 802.11b/g Restrictions

- France—In all Metropolitan départements, wireless LAN frequencies can be used under the following conditions, either for public or private use:
Indoor use: maximum power (EIRP) of 100 mW for the entire 2400-2483.5 MHz frequency band.

Japan

EN 55022 Statement (applicable to AP201 Rev 2, AP208 Rev 2 only). This is to certify that the above models are shielded against the generation of radio interference in accordance with the application of Council Directive 2004/108/EC, Annex I, 1a. Conformity is declared by the application of EN 55022 Class B (CISPR 22). Compliance is dependent upon the use of shielded data cables.

Model AP300



Model AP300 module rev 1

003WWA080094 003GZA080095 003XWA080096

Model AP150



003NY06122 0000 003GZ06030 0000 003WY06046 0000

Singapore

For the AP201 Rev 2, AP208 Rev 2, and OAP180, the following approval information applies:

**Complies with
IDA Standards
DA103798**

For the AP300 series, the following approval information applies:

**Complies with
IDA Standards
DB102245**

Manufacturing Information

The AP1000 and AP300 are built in Taiwan. Factory information is provided under NDA and upon request.

AP Plenum Requirements

When installing APs in an air-handling space, as described in Article 300.22(C) of the NEC (2005), the unit should only be powered by the Ethernet port (PoE), not by the AC-powered power supply.

When the product is installed in air-handling spaces, the cables employed should be suitable under NEC Articles 300.22 and 725 and marked accordingly, for use in plenums and air-handling spaces with regard to smoke propagation, such as CL2-P, CL3-P, MPP or CMP.

The products should be installed in accordance with all applicable, local regulations and practices.

Manufacturers Federal Communication Commission Declaration of Conformity Statement

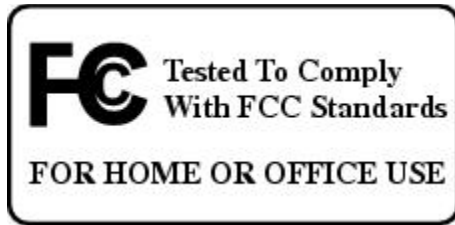

Access Point Models	Certification Number
AP832e	
AP832i	

Manufacturer:

Meru Networks, Inc
894 Ross drive,
Sunnyvale, CA 94089
USA

This device complies with Part 15 rules. Operation is subject to the following two conditions:

4. This device may not cause harmful interference, and
5. This device must accept any interference received, including interference that may cause undesired operation.

This device operates in the 5150-5250MHz and 5470-5725MHz bands and is therefore restricted to indoor operation only per FCC guidance.

This equipment has been tested and found to comply with the limits of a Class B digital device, pursuant to Part 15 of the FCC Rules. These limits are designed to provide reasonable protection against harmful interference when the equipment is operated in a residential environment. This equipment generates, uses, and radiates radio frequency energy, and if not installed and used in accordance with the instructions, may cause harmful interference. However, there is no guarantee that interference will not occur. If this equipment does cause interference to radio or television reception, which can be determined by turning the equipment off and on, the user is encouraged to correct the interference by one of the following measures:

- Reorient or relocate the receiving antenna.
- Increase separation between the equipment and receiver.
- Connect the equipment to an outlet on a circuit different from which the receiver is connected.
- Consult the dealer or an experienced radio/TV technician.



Caution!

The Part 15 radio device operates on a non-interference basis with other devices operating at this frequency when using the integrated antennas. Any changes or modification to the product not expressly approved by Meru could void the user's authority to operate this device.



Caution!

Within the 5.15 to 5.25 GHz and 5.47-5.725 GHz bands, this device is restricted to indoor operations to reduce any potential for harmful interference to co-channel Mobile Satellite System (MSS) operations.

VCCI Statement for Japan

 Warning!	<p>This is a Class B product based on the standard of the Voluntary Control Council for Interference from Information Technology Equipment (VCCI). If this is used near a radio or television receiver in a domestic environment, it may cause radio interference. Install and use the equipment according to the instruction manual.</p>
警告	<p>この装置は、クラスB情報技術装置です。この装置は、家庭環境で使用することを目的としていますが、この装置がラジオやテレビジョン受信機に近接して使用されると、受信障害を引き起こすことがあります。 取扱説明書に従って正しい取り扱いをして下さい。</p> <p style="text-align: right;">VCCI-B</p>

Guidelines for Operating Meru AP832e and AP832i Access point

This section provides guidelines for avoiding interference when operating Meru access points in Japan. These guidelines are provided in both Japanese and English.

This equipment operates in the same frequency bandwidth as industrial, scientific, and medical devices such as microwave ovens and mobile object identification (RF-ID) systems (licensed premises radio stations and unlicensed specified low-power radio stations) used in factory production lines.

1. Before using this equipment, make sure that no premises radio stations or specified low-power radio stations of RF-ID are used in the vicinity.
2. If this equipment causes RF interference to a premises radio station of RF-ID, promptly change the frequency or stop using the device; contact the number below and ask for recommendations on avoiding radio interference, such as setting partitions.
3. If this equipment causes RF interference to a specified low-power radio station of RF-ID

Industry Canada

Canadian Compliance Statement

Access Point Models	Certification Number
AP832e	
AP832i	

This Class B Digital apparatus meets all the requirements of the Canadian Interference-Causing Equipment Regulations.

Cet appareil numérique de la classe B respecte les exigences du Règlement sur le matériel brouilleur du Canada.

This device complies with Class B Limits of Industry Canada. Operation is subject to the following two conditions:

1. This device may not cause harmful interference, and
2. This device must accept any interference received, including interference that may cause undesired operation.

Meru Access Points are certified to the requirements of RSS-210. The use of this device in a system operating either partially or completely outdoors may require the user to obtain a license for the system according to the Canadian regulations. For further information, contact your local Industry Canada office.

This device has been designed to operate with antennas having a maximum gain of 7 dBi. Antennas having a gain greater than 7 dBi are strictly prohibited for use with this device. The required antenna impedance is 50 ohms.

To reduce potential radio interference to other users, the antenna type and its gain should be so chosen that the equivalent isotropically radiated power (EIRP) is not more than that permitted for successful communication.

EU Regulatory Conformance

Access Point Models:

AP832e

AP832i

This product is CE marked according to the provisions of the R & TTE Directive (99/5/EC) - CE 2280(!){! In circle}. Meru Networks Inc. , hereby declares that this AP832e and AP832i models are in compliance with the essential requirements and other relevant provisions of Directive 1999/5/EC. CE 2280(!)



Declaration of Conformity with regard to the R&TTE Directive 1999/5/EC

This equipment is in compliance with the essential requirements of other relevant provisions of Directive 1999/5/EC

The following standards were applied:

EMC-EN 301.489-1 v1.8.1; EN 301.489-17 v2.1.1

Health & Safety-EN60950-1: 2005; EN 50385: 2002

Radio-EN 300 328 v 1.7.1; EN 301.893 v 1.5.1

The conformity assessment procedure referred to in Article 10.4 and Annex III of Directive 1999/5/EC has been followed.



Note: This equipment is intended to be used in all EU and EFTA countries. Outdoor use may be restricted to certain frequencies and/or may require a license for operation.

Declaration of Conformity for RF Exposure

This section contains information on compliance with guidelines related to RF exposure.

This Device Meets International Guidelines for Exposure to Radio Waves

The AP832e and AP832i device includes radio transmitters and receivers. It is designed not to exceed the limits for exposure to radio waves (radio frequency electromagnetic fields) recommended by international guidelines. The guidelines were developed by an independent scientific organization (ICNIRP) and include a substantial safety margin designed to ensure the safety of all persons, regardless of age and health.

As such the systems are designed to be operated as to avoid contact with the antennas by the end user. It is recommended to set the system in a location where the antennas can remain at least a minimum distance as specified from the user in accordance to the regulatory guidelines which are designed to reduce the overall exposure of the user or operator.

Separation Distance		
MPE	Distance	Limit
0.63 mW/cm ²	20 cm (7.87 inches)	1.00 mW/cm ²

The World Health Organization has stated that present scientific information does not indicate the need for any special precautions for the use of wireless devices. They recommend that if you are interested in further reducing your exposure then you can easily do so by reorienting antennas away from the user or placing the antennas at a greater separation distance than recommended.

This Device Meets FCC Guidelines for Exposure to Radio Waves

The AP832e and AP832i include radio transmitters and receivers. It is designed not to exceed the limits for exposure to radio waves (radio frequency electromagnetic fields) as referenced in FCC Part 1.1310. The guidelines are based on IEEE ANSI C 95.1 (92) and include a substantial safety margin designed to ensure the safety of all persons, regardless of age and health.

As such the systems are designed to be operated as to avoid contact with the antennas by the end user. It is recommended to set the system in a location where the antennas can remain at least a minimum distance as specified from the user in accordance to the regulatory guidelines which are designed to reduce the overall exposure of the user or operator.

The device has been tested and found compliant with the applicable regulations as part of the radio certification process.

Separation Distance		
MPE	Distance	Limit
0.63 mW/cm ²	20 cm (7.87 inches)	1.00 mW/cm ²

The FCC recommends that if you are interested in further reducing your exposure then you can easily do so by reorienting antennas away from the user or placing the antennas at a greater separation distance than recommended or lowering the transmitter power output.

This Device Meets the Industry Canada Guidelines for Exposure to Radio Waves

The AP832e and AP832i include radio transmitters and receivers. It is designed not to exceed the limits for exposure to radio waves (radio frequency electromagnetic fields) as referenced in Health Canada Safety Code 6. The guidelines include a substantial safety margin designed into the limit to ensure the safety of all persons, regardless of age and health.

As such the systems are designed to be operated as to avoid contact with the antennas by the end user. It is recommended to set the system in a location where the antennas can remain at least a minimum distance as specified from the user in accordance to the regulatory guidelines which are designed to reduce the overall exposure of the user or operator.

Separation Distance		
MPE	Distance	Limit
0.63 mW/cm ²	20 cm (7.87 inches)	1.00 mW/cm ²

Health Canada states that present scientific information does not indicate the need for any special precautions for the use of wireless devices. They recommend that if you are interested in further reducing your exposure you can easily do so by reorienting antennas away from the user, placing the antennas at a greater separation distance than recommended, or lowering the transmitter power output.

Maximum EIRP

The transmit EIRP is the sum of the transmit power and the antenna gain. By default, the EIRP is set lower than the regulator limit with the default rubber duct antenna. For any higher gain antennas, transmit power is reduced via the CLI to keep the EIRP below the regulatory limit.

Dual Concurrent Same Band Operation

When both AP radios are operating on the same band simultaneously, their transmit power is reduced by 3 dBm.

AP Plenum Requirements