



Meru OAP180 Rugged Access Point

Special Release Notes

Beta Release 3.4-SR2

Copyright © Meru Networks, Inc., 2003-2007. All rights reserved.
Other names and brands may be claimed as the property of others.

Contents

- [Introduction](#)
- [OAP180 Access Point Features](#)
- [OAP180 Hardware Installation Instructions](#)
- [Limitations and Advisories](#)
- [Documentation for this Release](#)
- [Contacting Meru](#)

Introduction

This special release note introduces the Meru OAP180 Access Point, a new outdoor addition to the Meru Wireless LAN (WLAN) System. Read this note before installing or using the OAP180 Access Point and the corresponding System Director version 3.4-SR2. The release notes for System Director release 3.4-83 (March 2007) also apply to this release for known issues. Please read both release notes prior to installing or using this release.

OAP180 Access Point Features

The OAP180 Rugged Access Point is an outdoor AP with these features:

- [Designed for Harsh Conditions](#)
- [Best-in-class Meru AirShield Security](#)
- [Operation with all Meru Controllers and Access Points](#)
- [Multiple Antennas Supported for Specific Needs](#)

Designed for Harsh Conditions

The OAP180 Access Point with dual-radio is designed to provide secure Wi-Fi connectivity to outdoor locations such as campuses, parking lots, and pole tops, or to harsh indoor locations such as breweries, food processing plants or warehouses. The OAP180 includes basic Voice over WLAN (VoWLAN) support. Other features include:

- Automatic AP discovery and configuration
- No channel planning required with single channel installations
- Controller in the distribution or core layer extends VLAN trunks to the edge of the network
- Intelligent load balancing of clients
- PoE (Power over Ethernet) support
- RoHS compliant

Best-in-class Meru AirShield Security

All Meru APs provide these multi-layered security policies that protect the data, the network and the users simultaneously:

- Local and RADIUS MAC Filtering
- WPA2, WPA, 802.1x, and WEP
- No security information contained within access point
- Operates only with Meru controllers
- Multiple static or automatic security zones with individual security policies help ensure separation of different user groups or dynamic VLAN assignments per user based on Radius credentials - includes guest access security zone.
- The OAP 180 also has a locking mechanism to secure it when mounted in public areas.

Operation with all Meru Controllers and Access Points

The OAP180 operates with all currently supported Meru controllers and APs.

- Centralized dashboard monitors and troubleshoots the entire WLAN, including OAP180 access points
- Complete support of release 3.4 standard and optional features such as N+1 Redundant Controller, Dual-Ethernet, and Per-User Firewall

Multiple Antennas Supported for Specific Needs

WLAN Client Support

The following WLAN clients are supported:

- Dual 802.11a and 802.11b/g radios
- Simultaneous support for 802.11a, 802.11b, and 802.11g clients
- Co-channel interference management for reliable WLAN access
- Basic VoWLAN QoS support for small density deployments of voice clients

Special Release Software for Meru Controllers

Target Build Details

The following list describes the size and checksums for the system images, based on the model of controller in use. **Do not load onto your controller an image that is intended for another controller model, or problems will occur.**

- meru-3.4.SR2-10-MC500-rpm.tar Checksum: 3958546189 Size: 43581440
- meru-3.4.SR2-10-MC1000-rpm.tar Checksum:1023491239 Size:43663360
- meru-3.4.SR2-10-MC1100-rpm.tar Checksum:1359995275 Size:43663360
- meru-3.4.SR2-10-MC3000-rpm.tar Checksum:1023491239 Size:43663360

Install the Special Release Image on Your Controller

The installation of the special release image is performed with the normal Meru upgrade procedure, summarized in the following steps.

1. Obtain the system image.

In this example, the special release image for the MC500, **meru-3.4.SR2-10-MC500-rpm.tar 3958546189 43581440**, is retrieved using FTP from the images directory on the server named myserver using the username user1 and password userpass. Use the **upgrade system** command to upgrade the system. To configure the system so that you do not need to type the FTP username and password when transferring files, use the

`ip ftp|sftp|scp|tftp` username and `ip ftp|sftp|scp` password commands. (Using these commands is optional. If you do not set the username and password before transferring files, you must provide the username and password when prompted.)

```
mc500# configure terminal
mc500(config)# ip ftp username user1
mc500(config)# ip ftp password userpass
mc500(config)# ^Z
mc500# dir ftp://myserver/images/
total 134576
-rw-rw-r-- 1 root root 21790720 Jul 14 17:03 meru-3.2SR2-9-
MC500.tar
mc500# cd images
mc150# copy ftp://myserver/images/meru-3.4.SR2-10-MC500-
rpm.tar
```

2. If you see an error message stating that there is not enough free disk space, use the `show flash` command to see if there are previous images on the flash. Delete the previous image using the `delete flash version` command. Then try the `copy` command again.
3. After the image transfer is complete, use `show flash` to verify the system is on the flash.
4. Enter the `upgrade system version` command to update the controller and OAP software:

```
mc500# upgrade system 3.4.SR2-10
```

The system is now upgraded. Log in as `admin` to access the system.

OAP180 Hardware Installation Instructions

Perform the procedures in the following sections to install the OAP180 and configure the controller to use this special release.

- [Unpack the OAP180](#)
- [Plan the Location](#)
- [Test Basic Link Operation](#)
- [Mount the Unit](#)
- [Connect External Antennas and Ground Wire to OAP180](#)
- [Connect Cables to the Unit](#)
- [Connect the Power Injector](#)
- [Align Antenna](#)
- [Check the OAP180 for Activity](#)
- [Configure the OAP180 Access Point](#)

Unpack the OAP180

Confirm that the OAP180 shipping box contains the following items:

- Meru Networks Meru OAP180 Outdoor Access Point (see Figure 1).

Figure 1: OAP180

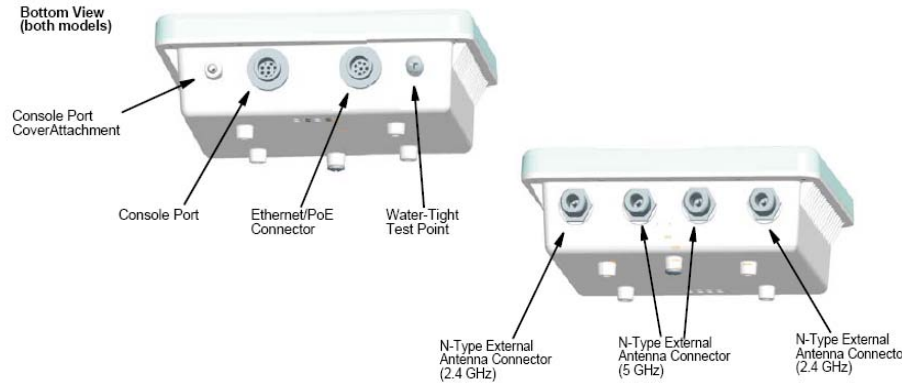

- Wall/Pole Mount Hardware Kit for mounting OAP180 to a 1.5" to 2" diameter steel pole or tube or as part of a radio or tower structure
- Bar code labels listing the MAC address and serial number (for Beta test, these are already attached to the unit)
- Outdoor CAT5 Ethernet cable—100 feet
- PoE injector with power cord

Additional Equipment Needed

In addition to the hardware supplied by Meru Networks, you need the following:

Required

- Standard Ethernet cable to connect the POE injector to a switch or controller
- Two external antennas (provided by Meru Networks only for Beta test)

Optional

- Ground wire for the OAP180
- RF coaxial cable to connect the antenna to the OAP180

Plan the Location

When you plan the OAP180 physical configuration, include the elements shown in this drawing:

Figure 2: Sample Physical Layout

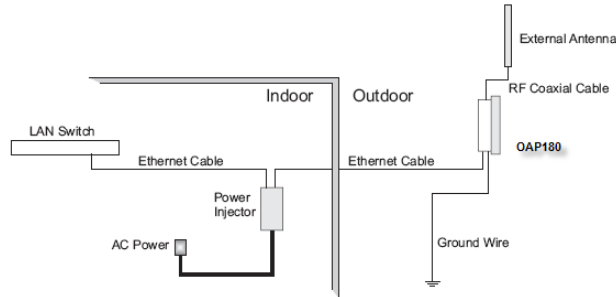

Radio Position Planning

Never construct a radio mast, pole, or tower near overhead power lines. In addition, local regulations may limit or prevent construction of a high radio mast or tower. If your OAP180 link requires a high radio mast or tower, consult a professional contractor for advice. Once the required antenna height has been determined, other factors affecting the precise position of the OAP180 must be considered.

- Be sure there are no other radio antennas within 2 m (6 ft) of the OAP180.
- Place the OAP180 away from power and telephone lines.
- Avoid placing the OAP180 too close to any metallic, reflective surfaces, such as roof-installed air-conditioning equipment, tinted windows, wire fences, or water pipes.

Radio Interference

Avoiding radio interference is an important part of wireless planning. Interference is caused by other radio transmissions using the same or an adjacent channel frequency. You should first scan your proposed site using a spectrum analyzer to determine if there are any strong radio signals using the 802.11a or 802.11bg channel frequencies. Always use a channel frequency that is furthest away from another signal.

Weather Conditions

Take into account any extreme weather conditions that are known to affect your location. Consider these factors:

- **Temperature** — The OAP180 is tested for normal operation in temperatures from -40°C to 140°C. Operating in temperatures outside of this range may cause the unit to fail.

- **Wind Velocity** — The OAP180 can operate in winds up to 44 m/s and survive higher wind speeds up to 66 m/s. You must consider the known maximum wind velocity and direction at the site and be sure that any supporting structure, such as a pole, mast, or tower, is built to withstand this force.
- **Lightning** — The OAP180 includes its own built-in lightning surge protection. However, you should make sure that the unit, any supporting structure, and cables are all properly grounded. Additional protection using lightning rods, lightning arrestors, or surge suppressors may also be employed. Antenna sockets should point upwards in a vertical manner
- **Rain** — The OAP180 is weatherproofed against rain. Also, prolonged heavy rain has no significant effect on the radio signal. However, it is recommended to apply weatherproof sealing tape around the Ethernet port and antenna connectors for extra protection. If moisture enters a connector, it may cause a degradation in performance or even a complete failure of the link.
- **Snow and Ice** — Falling snow, like rain, has no significant effect on the radio signal. However, a build up of snow or ice on antennas may cause the link to fail. In this case, the snow or ice has to be cleared from the antennas to restore operation of the link.

Ethernet Cabling

When a suitable antenna location has been determined, plan a cable route from the OAP180 outdoors to the power injector module indoors. Consider these points:

- The Ethernet cable length should never be longer than 100 m (328 ft).
- Determine a building entry point for the cable.
- Determine if conduits, bracing, or other structures are required for safety or protection of the cable.
- For lightning protection at the power injector end of the cable, consider using a lightning arrestor immediately before the cable enters the building.

Grounding

It is important that the OAP180, cables, and any supporting structures are properly grounded. The OAP180 unit includes a grounding screw for attaching a ground wire. Be sure that grounding is available and that it meets local and national electrical codes.

Test Basic Link Operation

Set up the OAP180 on the ground, either outdoors or indoors. Connect the unit as indicated in this document and perform the basic configuration tasks outlined below. When you are satisfied that the OAP180 is operating correctly, proceed to mounting the unit in the intended location.

Mount the Unit

The OAP180 can be mounted on the following two surfaces (brackets are included):

- 1.5 to 2 inch diameter pole
- Wall

Mounting OAP180 with the Pole-Mounting Bracket

Perform the following steps to mount the unit to a 1.5 to 2 inch diameter steel pole or tube using the mounting bracket:

1. Attach the OAP180 to the mounting bracket shown in Figure 3.

Figure 3: Square Mounting Bracket Attaches to Bottom of OAP180

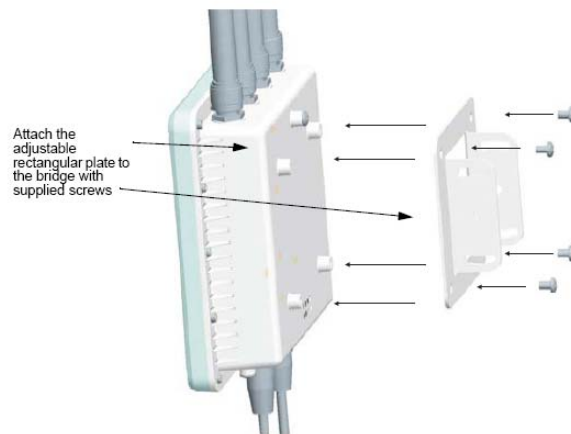

2. Place the V-shaped part of the bracket around the pole and tighten the securing nuts just enough to hold the bracket to the pole. (The bracket may need to be rotated around the pole during the alignment process.)

Note: Always attach the bracket to a pole with the open end of the mounting grooves facing up.

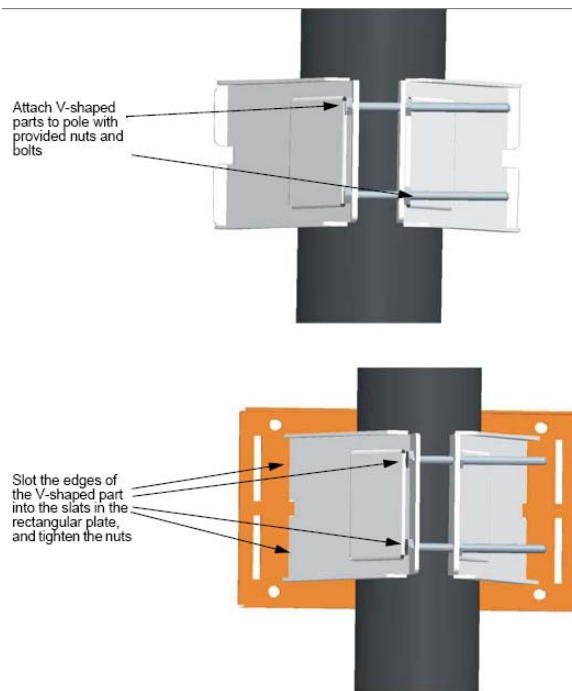

3. Use the included nuts to tightly secure the wireless OAP180 to the bracket.

4. Connect the OAP180 bracket and the pole bracket. See Figure 4.

Figure 4: Connecting the Two Brackets

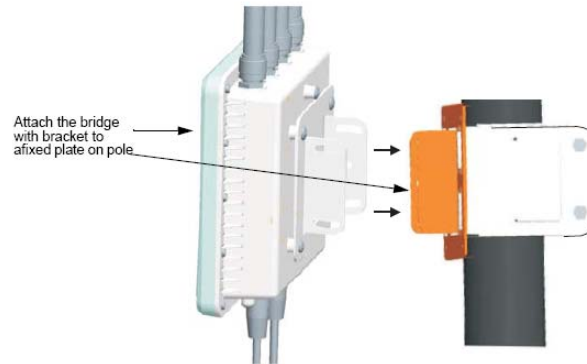

Mounting OAP180 with the Wall-Mounting Bracket

Attach the bracket to a wall with the flat side flush against the wall (see Figure 5). Perform the following steps to mount the unit to a wall using the wall-mounting bracket:

1. Position the bracket in the intended location and mark the position of the four mounting screw holes.
2. Drill holes in the wall that match the screws and wall plugs included in the bracket kit, and then secure the bracket to the wall.

Figure 5: Attaching Bracket to Wall

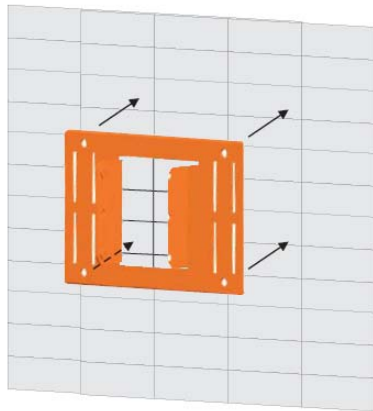

3. Use the included nuts to tightly secure the OAP180 to the bracket.

4. Connect the two brackets as shown in Figure 6.

Figure 6: Connecting the Two Brackets

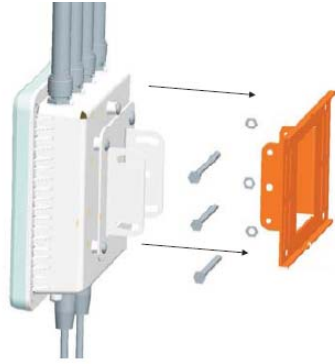

Connect External Antennas and Ground Wire to OAP180

When deploying an OAP180, first mount external antennas and then connect them to the OAP180. Follow these steps:

1. Mount the external antenna on the same supporting structure as you did the OAP180, within 3 m (10 ft) of it, using the bracket supplied in the antenna package.
2. Connect the antenna to the OAP180's N-type connector using the RF coaxial cable provided in the antenna package.

Figure 7: Connect the Antenna Cables

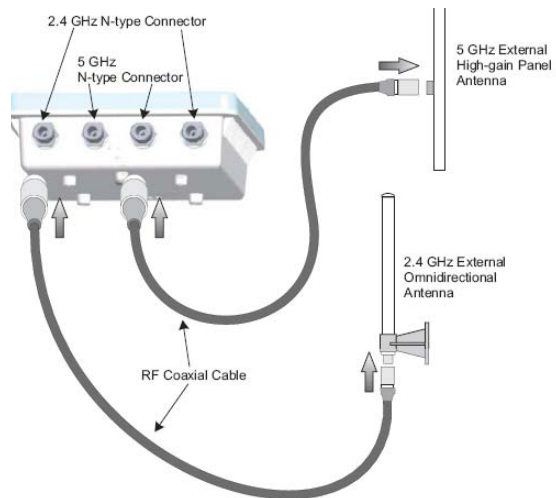

3. Apply weatherproofing tape to the antenna connectors to help prevent water entering the connectors.

Connect Cables to the Unit

Use only the provided Ethernet cable in step 1. Do not shorten this cable as the path loss is needed. During periods of lightning activity, do not connect or disconnect cables or otherwise work with the OAP180.

Perform the following steps to attach the Ethernet cable and ground wire:

1. Using the included cable, attach the Ethernet cable to the Ethernet port on the OAP180. See Figure 8.

Figure 8: Connecting the Ethernet Cable and Ground Wire

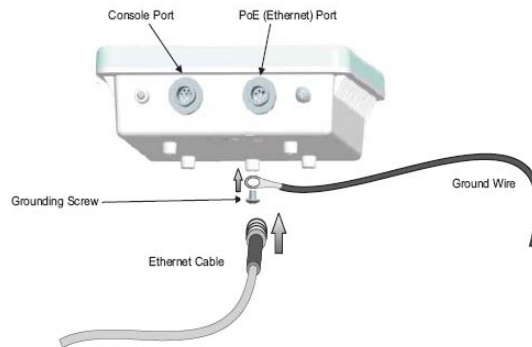

2. For extra protection against rain or moisture, apply weatherproofing tape (not included) around the Ethernet connector.
3. Ground the unit with an appropriate grounding wire (not included) by attaching it to the grounding screw on the unit. See Figure 8.

Caution! Be sure that grounding is available and that it meets local and national electrical codes. For additional lightning protection, use lightning rods, lightning arrestors, or surge suppressors.

Connect the Power Injector

Caution! Do not locate the power injector outdoors. The unit is for indoor use only.

Note: The wireless Ethernet port does not support Power over Ethernet (PoE) based on the IEEE 802.3af standard. Do not try to power the unit by connecting it directly to a network switch that provides IEEE 802.3af PoE. Always connect the unit to the included power injector module.

Perform the following steps to connect the power injector:

1. Connect the other end of the provided Ethernet cable (already connected to the OAP180) to the RJ-45 port labeled *Output* on the power injector. See Figure 9.

Figure 9: Connecting the Power Injector

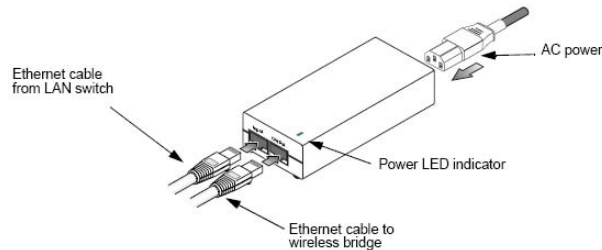

2. Connect a straight-through unshielded twisted-pair (UTP) cable (not included) from a local LAN switch to the RJ-45 port labeled *Input* on the power injector. See Figure 9. Use Category 5e or better UTP cable for 10/100BASE-TX connections.

Note: The RJ-45 port on the power injector is an MDI port. If connecting directly to a computer for testing the link, use a crossover cable.

3. Insert the power cable plug directly into the standard AC receptacle on the power injector. See Figure 9.
4. Plug the other end of the power cable into a grounded, 3-pin socket, AC power source.

Note: For International use, you may need to change the AC line cord. You must use a line cord set that has been approved for the receptacle type in your country.

5. Check the LED on top of the power injector to be sure that power is being supplied to the OAP180 through the Ethernet connection.

Align Antenna

After the OAP180 unit is mounted, connected, and the radios are operating, the antennas must be accurately aligned to ensure optimum performance of the OAP180 links. In this point-to-multipoint configuration all OAP180 nodes must be aligned with the root OAP180 antenna.

Check the OAP180 for Activity

Check the OAP180 LEDs for activity. Four of the eight LEDs on the bottom of the OAP180 indicate activity; four LEDs are not used at this time. Check the four active LEDs to determine if the AP is working.

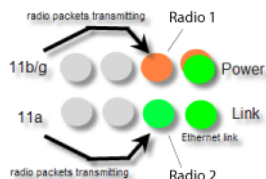

The grey LEDs in the illustration are not currently used. The following chart explains the meanings for the remaining LEDs.

LEDs	Function
Power	When power is applied to the system this LED initially turns amber, then blinks green when the system power check is applied, and then is a steady green when power is on.
Ethernet Link	The Ethernet Link LED blinks green when a link has been detected and is in use.
Radio 1 11bg	The 11bg connection LED blinks amber when radio packets are being transmitted and when the radio is beaconing. If there is traffic over the air on this radio, the blinking rate increases.
Radio 2 11a	The 11a connection LED blinks green when radio packets are being transmitted and when the radio is beaconing. If there is traffic over the air on this radio, the blinking rate increases.

Configure the OAP180 Access Point

Once the OAP180 is plugged in, the Meru controller will detect and connect the OAP180. The OAP180 can then be further configured through either the Controller GUI or CLI.

[Configure OAP180 Radio Operation with the Web UI](#)

[Configure OAP180 Radio Antennas with the CLI](#)

[Configure OAP180 Radio Operation with the CLI](#)

Configure OAP180 Radio Operation with the Web UI

To use the Web UI to set up the OAP180, follow these steps from the controller:

1. Click **Configuration** and then **Radio** from the Devices list. A table of Wireless AP Interface Details displays.
2. Select the checkbox of the second wireless interface of the OAP180 that requires modification, and then click **Settings**. The Wireless Interface Configuration Update page displays.
3. From the Channel drop-down list, select the channel the interface will use (channels have been filtered to only reflect appropriate selections).
4. From the RF Band Selection drop-down list, select **802.11a**
5. Click **OK** to save your change and return to the Wireless Interface Configuration page.
6. Select the checkbox for the first wireless interface of the OAP, and click **Settings**. The Wireless Interface Configuration displays.
7. From the Channel drop-down list, select the channel the interface will use (channels have been filtered to only reflect appropriate selections).
8. From the RF Band Selection drop-down list, select **802.11b**, **802.11g**, or **802.11bg**. Default mode is **802.11bg**.
9. Click **OK** to save your change and return to the Wireless Interface Configuration page.
10. Continue setting any other OAPs as needed, by repeating the above steps.
11. Save this configuration by clicking on **Save**.

Configure OAP180 Radio Operation with the CLI

To configure radio parameters of OAP180 through the IOSCLI, follow these steps from controller. This example uses AP ID 1 and interface IDs 1 and 2:

1. First, configure AP ID 1 and Interface ID 1 (B/G Interface):

```
MC3000# configure terminal
MC3000(config)# interface Dot11Radio 1 1
MC3000(config-if-802)# channel 1
MC3000(config-if-802)# rf-mode 802.11g
MC3000(config-if-802)# exit
MC3000(config)#
```

2. Next, configure AP ID 1 and Interface ID 2 (A Interface):

```
MC3000(config)# interface Dot11Radio 1 2
MC3000(config-if-802)# channel 48
MC3000(config-if-802)# exit
MC3000(config)# exit
```

3. Save the configuration:

```
MC3000# copy running-config startup-config
```

4. Check the configuration of both interfaces:

```
MC3000# show interfaces Dot11Radio 1 1
Wireless Interface Configuration
AP ID                               : 1
AP Name                             : OAP180
Interface Index                     : 1
AP Model                            : OAP180
Description                          : ieee80211-1-1
Administrative Status               : Up
Operational Status                  : Disabled
Last Change Time                    : 2007/04/26 01:18:29
Radio Type                          : RF3
MTU (bytes)                         : 2346
Channel                             : 1
Short Preamble                      : on
RF Band Support                     : 802.11bg
RF Band Selection                   : 802.11g
Antenna Selection                   : Left
Transmit Power (dBm) (low,medium,high) : 20,20,20
AP Mode                             : Normal
Fixed Channel                       : off
Scanning Channels                   :
Protection Mechanism                 : 802.11-1999
Protection Mode                     : auto
Number of Antennas                  : 1
Dual abg Support                    : off
```

```
MC3000# show interfaces Dot11Radio 1 2
Wireless Interface Configuration
AP ID : 1
AP Name : OAP180
Interface Index : 2
AP Model : OAP180
Description : ieee80211-1-2
Administrative Status : Up
Operational Status : Disabled
Last Change Time : 2007/04/26 01:18:29
Radio Type : RF3
MTU (bytes) : 2346
Channel : 40
Short Preamble : off
RF Band Support : 802.11a
RF Band Selection : 802.11a
Antenna Selection : Right
Transmit Power (dBm) (low,medium,high) : 17,17,17
AP Mode : Normal
Fixed Channel : off
Scanning Channels :
Protection Mechanism : 802.11-1999
Protection Mode : auto
```

Configure OAP180 Radio Antennas with the CLI

Configure OAP180 antennas with the following CLI commands. This example uses AP ID 10 and radios 1 and 2:

1. Enter the Radio sub-mode from global configuration, by specifying the AP ID (10 in the example) and first interface that you intend to configure:

```
default# configure terminal  
default(config)# interface Dot11Radio 10 1
```

2. Enter the antenna-property submode interface 1:

```
default(config-if-802)# antenna-property 1
```

3. Set the antenna type to External:

```
default(config-if-802-antenna)# type External
```

4. Set the antenna band to dual, and exit the mode:

```
default(config-if-802-antenna)# rband dual  
default(config-if-802-antenna)# end  
default(config-if-802)# end  
default(config)# end
```

5. Reboot the system.

6. Check the configuration of both interfaces:

```
default# show interfaces Dot11Radio 1 1
```

```
default# show interfaces Dot11Radio 1 2
```

Limitations and Advisories

Known Bugs for this Release

BUG ID	Summary

Other Significant Issues with this Release

None

Regulatory Information

Radio

- FCC Part 15
- Canada RSS210
- EN 300 328 V1.6.1 (11/2004)
- EN 301 893 V1.3.1 (08/2005)
- Japan Technical Regulations

EMC

- FCC Part 15
- EN 301 489-17 V1.2.1 (08/2002)
- Japan VCCI

Safety

- cUL 60950-1 First Edition
- IEC/EN 60950-1 First Edition
- with national deviations
- UL 50; Enclosures for Electrical Equipment

FCC Statement

This equipment has been tested and found to comply with the limits for a Class B digital device, pursuant to Part 15 of the FCC Rules. These limits are designed to provide reasonable protection against harmful interference in a residential installation. This equipment generates, uses and can radiate radio frequency energy and, if not installed and used in accordance with the instructions, may cause harmful interference to radio communications. However, there is no guarantee that interference will not occur in a particular installation. If this equipment does cause harmful interference to radio or television reception, which can be determined by turning the equipment off and on, the user is encouraged to try to correct the interference by one of the following measures:

- Reorient or relocate the receiving antenna.
- Increase the separation between the equipment and receiver.
- Connect the equipment into an outlet on a circuit different from that to which the receiver is connected.
- Consult the dealer or an experienced radio/TV technician for help.

FCC Caution

Any changes or modifications not expressly approved by the party responsible for compliance could void the user's authority to operate this equipment.

This device complies with Part 15 of the FCC Rules. Operation is subject to the following two conditions: (1) This device may not cause harmful interference, and (2) this device must accept any interference received, including interference that may cause undesired operation.

This device and its antenna(s) must not be co-located or operation in conjunction with any other antenna or transmitter.

FCC Radiation Exposure Statement

This equipment complies with FCC radiation exposure limits set forth for an uncontrolled environment. This equipment should be installed and operated with minimum distance 20cm between the radiator & your body.

For product available in the USA market, only channel 1~11 can be operated.

Selection of other channels is not possible.

FCC NOTICE

To comply with FCC part 15 rules in the United States, the system must be professionally installed to ensure compliance with the Part FCC 15 certification

It is the responsibility of the operator and professional installer to ensure that only certified systems are deployed in the United States. The use of the system in any other combination (such as co-located antennas transmitting the same information) is expressly forbidden.

CE Statement

Hereby, Meru, declares that this device is in compliance with the essential requirement and other relevant provisions of the R&TTE Directive 1999/5/EC.

This device will be sold in the following EEA countries: Austria, Italy, Belgium, Liechtenstein, Denmark, Luxembourg, Finland, Netherlands, France, Norway, Germany, Portugal, Greece, Spain, Iceland, Sweden, Ireland, United Kingdom, Cyprus, Czech Republic, Estonia, Hungary, Latvia, Lithuania, Malta, Slovakia, Poland, Slovenia.

Documentation for this Release

In addition to these release notes, the standard documentation and release notes for the 3.4 release apply to this release and describe the full System Director functionality and known issues.

- *Meru Wireless LAN System Release 3.4 Release Note*
- *Meru Wireless LAN System Getting Started Guide*
- *Meru Controller Installation Guide*
- *Meru Wireless LAN System Command Reference*
- *Meru Wireless LAN System Configuration Guide*

Contacting Meru

You can visit Meru Networks on the Internet at this URL:

<http://www.merunetworks.com>

Click [Support](#) to view Meru Customer Services and Support information.

Customer Services and Support

For assistance, contact Meru Customer Services and Support 24 hours a day at 1-888-637-8952 (1-888-Meru-WLA(N)) or 1-408-215-5305.

Send email to support@merunetworks.com.

Meru Customer Services and Support provide end users and channel partners with the following:

- Telephone technical support
- Software update support
- Spare parts and repair service