

# Chapter 2

## Installing AP300

This chapter describes how to install and configure an AP300. It contains the following sections:

- [Safety Precautions](#)
- [Unpack the AP300](#)
- [Determine Power Requirements](#)
- [Installation Requirements](#)
- [Install the AP300](#)
- [Check AP300 LED Activity](#)
- [Check AP300 LED Activity](#)
- [Where to Go From Here](#)

## Safety Precautions

---

**IMPORTANT**—Read and follow the regulatory instructions in Appendix B before installing and operating this product.

If an optional power supply is used, it must be one supplied by Meru Networks.

The AP300 is intended only for installation in Environment A as defined in IEEE 802.3af. All interconnected equipment must be contained within the same building, including the interconnected equipment's associated LAN connection.

## Best Practices for an AP300/AP1000 Network

---

Read this section if you have both AP1000 and AP320i active simultaneously on the same network. The following best practices should be followed to get optimal performance from such a mixed network.

- AP320i and AP300 are interchangeable and fully compatible to share a virtual cell. It's like having two AP300s with different antennas. The only difference is that AP320i is detected as a such in the UI of the controller.
- If possible, do not deploy AP1000 and AP300/AP320i at the same physical location; we recommend that there be no overlapping coverage between AP1000 and AP300.
- If AP1000 and AP300/AP320i do have overlapping coverage, you have two options. Deploy them on separate channels or make sure the ESS profiles on both AP types are unique. The chart below shows two ESS scenarios, one supported, one not supported.

Supported ESS Scenario	AP1000 Configuration	AP320i Configuration
Two Unique ESS profiles	ESS Profile name in controller is UniqueName1	ESS Profile name in controller is UniqueName2
AP1000 and AP320i SSID string over the air	Meru	Meru

Unsupported ESS Scenario	AP1000 Configuration	AP320i Configuration
Same ESS profiles	ESS Profile name in controller is same name	ESS Profile name in controller is same name
AP1000 and AP320i SSID string over the air	Meru	Meru

Assumptions for the above best practices include:

- AP1000 is using Virtual Port with BSSID Virtual Cell.
- AP320i is using Virtual Port with BSSID Virtual Cell.
- AP1000s and AP300s are on the same channel. (AP1000 and AP320i could also be on different channels.)
- AP1000s and AP320i is are on the same controller. (AP1000 and AP320i could also be on different controllers as long as each controller has a unique controller index.)

## Unpack the AP300

---

The AP300 series has five models as shown below.

Model	Radios
PSM3x	One a/b/g/n, one spectrum
AP320	Two a/b/g/n
AP311	One a/b/g/n, one a/b/g
AP310	One a/b/g/n
AP302	One a/b/g

Confirm that the AP300 shipping package contains these items:

- AP300 with attached mounting bracket
- Six antennas (four for PSM3x)
- Screws for the mounting bracket

## Determine Power Requirements

---

Power requirements vary, depending on which AP300 radios are deployed and what MIMO mode is used. See the chart below for supported power sources for different radio configurations.

Radio 1 MIMO	Radio 2 MIMO	802.3af PoE	802.3at PoE	DC Power
2x2	2x2	●	●	●
2x2	3x3	●	●	●
3x3	2x2	●	●	●
3x3	3x3	Do not recommend	● limitation below	●

### 802.af PoE Usage

When using System Director 3.6/4.0/4.1 and 802.3af PoE, Meru supports radios set to any MIMO settings except 3x3 on dual radios. This is because two radios set to 3x3 MIMO using an 802.3af switch may not have enough power if the cable is too long. Shorter cables frequently work, however. Meru supports:

- Single 3x3 radio
- Dual 2 x 2 radios
- Dual radio with one set to 2x2 and the other one set to 3x3

When using System Director 4.0 and 802.3af, the AP300 MIMO configuration is limited to the following:

- 3x3 for the 5 GHz radio
- 2x2 for the 2.4 GHz radio

### 802.3at PoE Usage

When using System Director 3.6/4.0/4.1 and 802.3at, the following radio combinations are recommended:

- Single 3x3 radio
- Dual 2 x 2 radios
- Dual radio with one set to 2x2 and the other one set to 3x3

- Dual 3x3 radios are recommended with a limitation. Use 802.3at power for two 3x3 MIMO radios when the switch has a high enough power output to support all devices on the PoE. Calculate the amount of power needed by each AP300/AP300i in 3x3 mode (13 watts), add that to power required by other PoE devices on the switch and compare that value to the total power output from the switch.

The calculation for 802.3at PoE use looks something like this:

$$(\text{Number of AP300s} * 13\text{watts}) + (\text{sum of all other PoE devices power requirements}) \leq \text{switch power provided}$$

For a list of supported PoEs, see the appendix [Supported Power Over Ethernet Devices for Meru APs](#)

## Installation Requirements

---

An array of holes on the mounting bracket allows the AP300 to be mounted on the wall and over junction boxes or molly bolts. There are holes for passing the PoE Ethernet or external power supply cable through the bracket if the bracket is mounted on a junction box. A template of this bracket is included in Appendix E of this guide.

The AP300 has a security cable slot so you can lock the AP300 with a standard security cable, such as those used to secure laptop computers.

Purchase optional mounting kits to mount the AP300 either from the ceiling or inside an enclosure:

- Suspended Ceiling Rail Mounting Kit: ACC-MNT-SCRMKIT
- Above Suspended Ceiling Mounting Kit (T-Bar Hanger): ACC-MNT-ASCMKIT
- Inside a Hoffman Enclosure using Hoffman compatible mounting bracket: ACC-AP300-BHE (enclosure not provided)
- Above hanging ceiling tiles. Suitable for use in environmental air space in accordance with the Section 300-22(c) of the National Electric Code and Sections 2- 128.12 - 010 (3) and 12 - 100 of the Canadian Electrical Code. Part 1. C22. 1.

To complete AP300 installation, you need the items listed below.

Installation Type	Items Required
Horizontal mounting	None
Vertical mounting over a wall stud	<ul style="list-style-type: none"> <li>● Two #6 x 2" wood screws for a wood stud; or</li> <li>● Two #6 x 1½" metal screws for a metal stud</li> <li>● Mounting bracket</li> </ul>

Install the AP300

Installation Type	Items Required
Vertical mounting on sheetrock	<ul style="list-style-type: none"> <li>• Two #6 x 1" screws</li> <li>• Two #4-6 x 7/8" ribbed plastic wall anchors</li> <li>• Mounting bracket</li> </ul>
Horizontal mounting below a hanging ceiling	<ul style="list-style-type: none"> <li>• Two caddy fasteners</li> <li>• Two plastic spacers</li> <li>• Two keps nuts (with attached lock washer)</li> <li>• Mounting bracket</li> </ul>
Using existing third party brackets	<ul style="list-style-type: none"> <li>• Use included shoulder screws</li> </ul>
Mounting above a ceiling tile	<ul style="list-style-type: none"> <li>• Two T-rail clips</li> <li>• One T-box hanger</li> <li>• One bracket mounting clip</li> <li>• Mounting bracket</li> </ul>

## Additional Equipment

A power source is needed to power the AP300. See [Determine Power Requirements](#).

## Install the AP300

---

[Select a Location](#)

[Attach the Provided Antennas](#)

[Install the Remote Antenna Mount \(optional\)](#)

[Install External ACC-ANT-MIMO-MNT Antenna with Three Connectors \(optional\)](#)

[Install Remote ACC-ANT-6ABGN-24 Antenna with Six Connectors \(optional\)](#)

[Install Antennas With One Connector \(optional\)](#)

[Install the Access Point](#)

## Select a Location

All AP300 interconnected equipment, including the associated LAN connection, must be contained within the same building. In addition, the AP300 location should meet the following conditions:

- Relatively unobstructed access to the stations the AP serves. Select a location with minimal physical obstructions between the AP and the wireless stations. In an office with cubicles, mounting the APs below a hanging ceiling (plenum is supported) or the wall near the ceiling provides the least obstructed communications path. On a wall, orient the AP300 horizontally so that you can read the Meru logo without tilting your head at 90 degrees - this orientation provides optimum MIMO performance.
- Access to wall outlet or a to a Power over Ethernet (PoE) connection to the network switch servicing the controller.
- We recommend planning for about 50 clients per radio (or per interference region) if you plan to use Virtual Port and plan to have phones as clients. For a data-only installation, plan up to 128 clients per radio, meaning 256 for AP320 and 128 for other AP300 models. Refer to the Meru Deployment Guides on the support site for more information.

AP300 is designed to provide 360 degree omni-directional coverage as illustrated below. Plan placement with this pattern in mind.

Figure 7: Coverage Pattern for AP300 When Ceiling Mounted

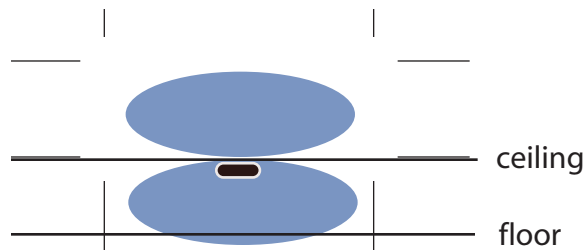

Most installations receive the best coverage using the following guidelines:

- Install APs toward the center of the building.
- Place APs about 80 feet apart.
- Do not install APs near metal objects, such as heating ducts, metal doors, or electric service panels.
- For best coverage, orient antennas as shown in [Figure 6](#).

## Attach the Provided Antennas

All AP300s have six external antenna ports, labeled 1 - 6. These units operate with six antennas attached, even though some configurations don't use all six. Instead of attaching an antenna, you can cap unused antenna connectors with 50 ohm Reverse Polarity SMA terminators. (For a list of approved terminators, see <http://www.merunetworks.com/merusupport>.) Meru supplied antennas are suitable only for indoor use unless they are mounted in an outdoor enclosure (see [Mount AP300 in a Hoffman Enclosure](#)). To achieve the best performance from your AP300, position antennas at a 90 degree angle relative to each other as shown in [Figure 6](#). The antennas do not have to be oriented exactly as shown in the figure, but it is important to maintain the relative angles. If for some reason you are unable to maintain those angles, the network still operates, but you may experience up to 20% drop in throughput depending on the antenna orientation.

Install the AP300

Figure 6: AP320, AP311 or AP302 Antennas 1-6 in Ceiling and Wall Mount Configuration

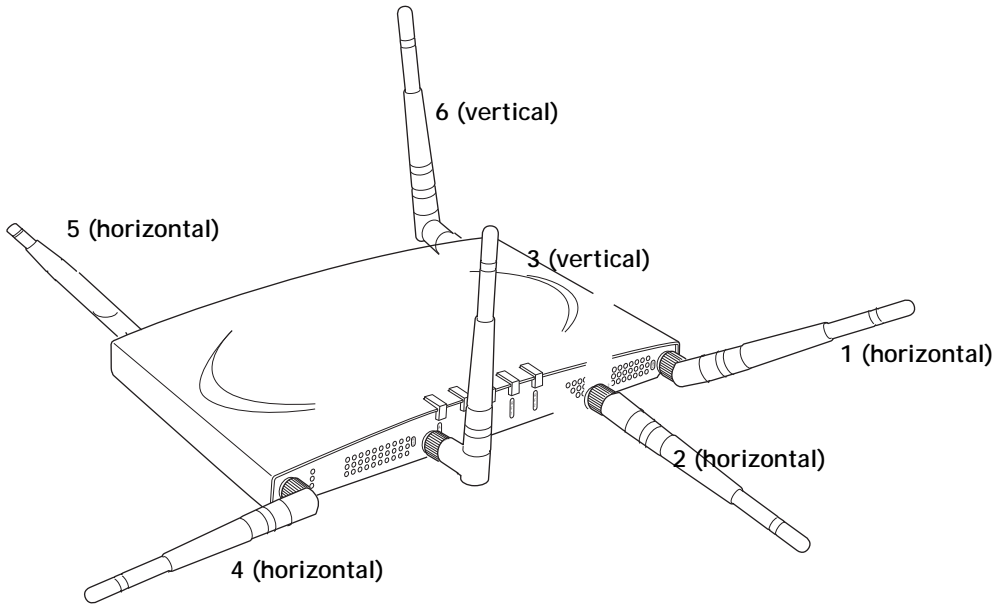

The following antenna connections are used during operation of the AP320, AP311, and AP302. Note that PSM3x APs will only have four antennas, rather than the typical six.

Table 1: AP300 With Two Radios and Corresponding Antennas

Model	Radio 1 (Ant4, Ant5, Ant6)	Radio 2 (Ant1, Ant2, Ant3)
PSM3x	a/b/g/n with 3 dual band omni-directional antennas (only one radio can be N)	Spectrum radio with one omni-directional antenna.
AP320	a/b/g/n with 3 dual band omni-directional antennas	a/b/g/n with 3 dual band omni-directional antennas
AP311	a/b/g/n with 3 dual band omni-directional antennas (only one radio can be N)	a/b/g/n with 3 dual band omni-directional antennas (only one radio can be N)
AP302	a/b/g with 3 dual band omni-directional antennas	a/b/g with 3 dual band omni-directional antennas

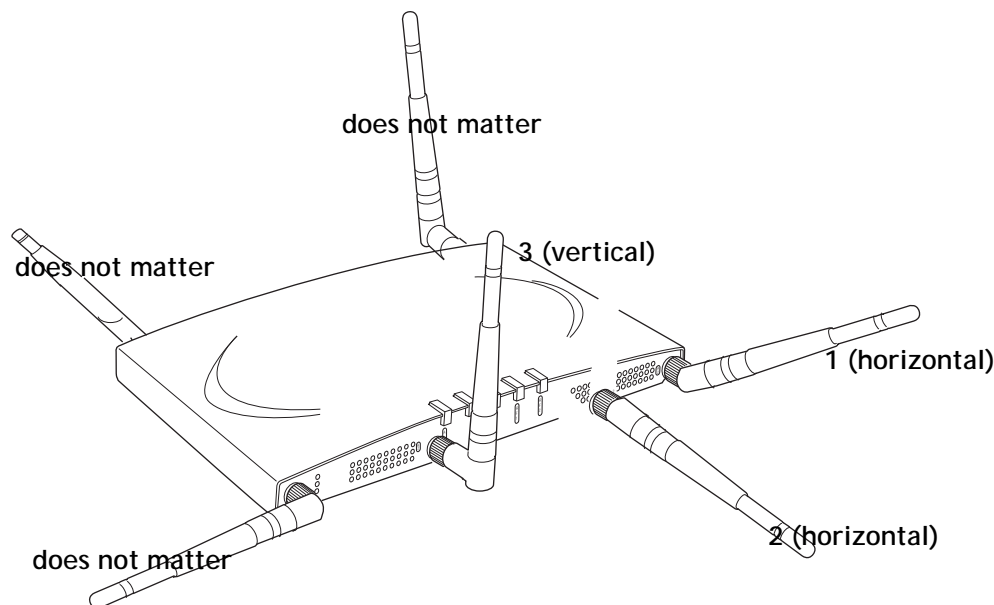

**Table 2: AP310 With One Radios and Corresponding Antennas**

Model	Radio 1 (Ant1, Ant2, Ant3)
AP310	a/b/g/n with 3 dual band omni-directional antennas

The AP310 has six external antenna ports labeled 1 - 6. However, AP310 uses only three of those antennas and the unused antenna connectors are blocked. [Figure 7](#) illustrates the recommended antenna configuration for the AP310.

**Figure 7: AP310 Antennas 1-3**



The following antenna connections are used during operation of the AP310.

Radio 1 Antenna Connectors for AP310	Radio2 Antenna Connectors for AP310
Ant1, Ant2, Ant3	NA

Do not leave any antenna connectors unterminated. All connectors on the AP must be terminated with antennas or with 50 ohm Reverse Polarity SMA terminators. (For a list of approved terminators, see <http://www.merunetworks.com/merusupport>).

The attached antennas must be the same model; if you replace one antenna, replace them all.

Install the AP300

## Install the Remote Antenna Mount (optional)

Use the optional Meru Remote Antenna Mount (ACC-ANT-MIMO-MNT) for one or both AP300 radios to remotely connect the AP300 antennas. The Remote Antenna Mount allows you to relocate either your current antennas or the optional high-gain dipole antennas to a location with clearer signal paths to the other wireless devices in your network. The Remote Antenna Mount can be installed either below the ceiling tile or on the wall. The default orientation for the mount is suitable for a ceiling mount, but you can attach the mount to a wall with some modifications.

Use one mount per radio; for example AP310 needs one unit, and AP320 needs two units. The Remote Antenna Mount uses low-loss plenum rated LMR195 cable and SMA connectors. To order this unit, contact your Meru sales representative and refer to part number ACC-ANT-MIMO-MNT.

Figure 8: Remote Antenna Mount

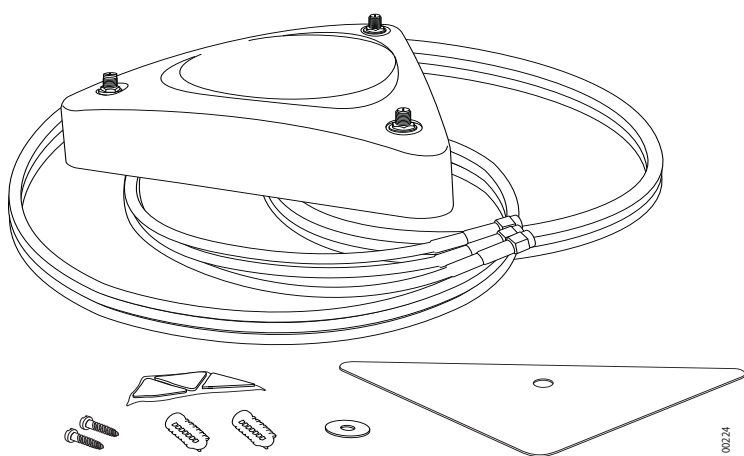

The remote antenna mount kit includes:

- Antenna stand with attached cable. The three antenna SMA female connectors on the Antenna Mount support AP300 antenna diversity. This feature gives the client the ability to automatically choose the antenna receiving the strongest signal.
- Triangular ceiling mount clip for attaching to hanging ceiling (includes bolt assembly)
- Three self-adhesive pads for the bottom of the unit (over the screws)
- Two wall mount screws with anchors
- Ceiling Mount Template
- Installation diagram

## Install the Remote Antenna Mount on the Ceiling

To connect the Remote Antenna Mount to the ceiling, refer to the installation diagram from the shipping box while following these steps:

1. Attach the shorter end of the screw to the center hole on the back of the Antenna Mount.
2. Remove the designated ceiling tile.

3. Using the template, drill holes in the ceiling tile.
4. Replace the ceiling tile.
5. Remove a ceiling tile adjacent to the newly drilled tile for access purposes.
6. Feed the Antenna Mount cable through the larger hole in the ceiling tile until the Antenna Mount is flush with the ceiling. The screw should now be visible above the ceiling tile (through the second hole).
7. Place the triangular plate above the ceiling tile with the screw aligned through the plate.
8. Drop the washer onto the screw and tighten the bolt.  
The Antenna Mount is now connected to the ceiling.
9. Replace the adjacent tile.
10. Connect the three Remote Antenna Mount cables to the appropriate connectors on the AP300. Be sure to connect the three antennas that correspond to one radio. Radio 1 uses A1, A2, A3 and Radio 2 uses A4, A5, A6.

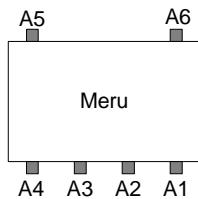

11. Attach three antennas that shipped with AP300 to the three connectors on the triangular remote device. See [Figure 8](#).

## Install the Remote Antenna Mount on a Wall

1. Reorient the cable on the Remote Antenna Mount by removing the three screws on the back, removing the small cover, reorienting the cable and then replacing the three screws. Discard the small cover.
2. Connect the three Remote Antenna Mount cables to the appropriate ports on the AP300. Be sure to connect the three antennas that correspond to one radio. Radio 1 uses A1, A2, A3 and Radio 2 uses A4, A5, A6. PSM3x devices only utilize A1, A2, A3, and A5.

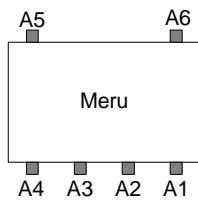

3. Attach three of the antennas that shipped with AP300 to the three ports on the triangular remote device.
4. Orient the connected AP300 horizontally so that you can read the Meru logo without tilting your head at 90 degrees - this orientation provides optimum MIMO performance.

Install the AP300

## Install External ACC-ANT-MIMO-MNT Antenna with Three Connectors (optional)

You can optionally use an external antenna setup with your AP300 if the controller and APs are running System Director 3.6.1MR4 and later. Meru supports this antenna for use on one radio using 802.11n MIMO. An AP300 with one radio, for example AP310, needs one antenna. An AP300 with two radios, for example AP320, needs two antennas. Radio One antenna cables connect to ports A1, A2, and A3. Radio Two cables connect to ports A4, A5, and A6. There is no preferred cabling connection; all three cables are the same.

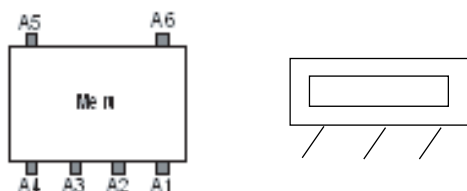

Calculate the antenna gain for the ACC-ANT-MIMO-MNT antenna by referring to the next three charts:

Band of Operation	Gain	Vertical Beamwidth	Horizontal Beamwidth
2.40-2.483 GHz	2.5dB	55 degrees	360 degrees
5.15-5.85 GHz	4dB	60 degrees	360 degrees

Using This Cable Type with 2.4 GHz	Calculate This Loss per Foot
RG174	0.60 dB
RG316	0.48 dB
LMR100	0.39 dB
LMR200	0.17 dB
LMR240	0.13 dB
LMR400	0.066 dB
LMR600	0.043 dB

Using This Cable Type with 5 GHz	Calculate This Loss per Foot
RG174	1.02
RG316	0.76
LMR100	0.59 dB

Using This Cable Type with 5 GHz	Calculate This Loss per Foot
LMR200	0.24 dB
LMR240	0.19 dB
LMR400	0.100 dB
LMR600	0.066 dB

Install the AP300

## Install Remote ACC-ANT-6ABGN-24 Antenna with Six Connectors (optional)

You can optionally use an external antenna setup with your AP300 if the controller and APs are running System Director 3.6.1MR4 and later. Meru supports this antenna for use on AP300s with two radios, for example AP320. This antenna has six connectors to connect to both radios to a dual-radio AP300 and it supports 802.11n MIMO operation.

The six cables on the ACC-ANT-6ABGN-24 antenna are already tagged with the numbers 1 - 6. Connect the antenna cables to the AP antenna ports as shown here:

Meru AP300 Antenna Connector	Antenna Cable Numbered
A1	6
A2	5
A3	4
A4	3
A5	2
A6	1

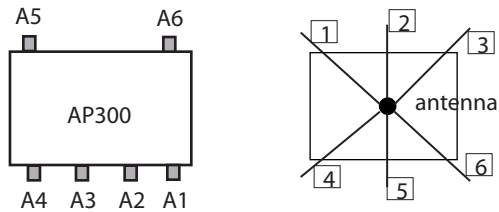

Calculate the antenna gain for the ACC-ANT-6ABGN-24 antenna by referring to the next three charts:

Band of Operation	Gain	Vertical Beamwidth	Horizontal Beamwidth
2.40-2.483 GHz	2.5dB	55 degrees	360 degrees
5.15-5.85 GHz	4dB	60 degrees	360 degrees

Using This Cable Type with 2.4 GHz	Calculate This Loss per Foot
RG174	0.60 dB
RG316	0.48 dB
LMR100	0.39 dB
LMR200	0.17 dB
LMR240	0.13 dB
LMR400	0.066 dB
LMR600	0.043 dB

Using This Cable Type with 5 GHz	Calculate This Loss per Foot
RG174	1.02
RG316	0.76
LMR100	0.59 dB
LMR200	0.24 dB
LMR240	0.19 dB
LMR400	0.100 dB
LMR600	0.066 dB

## Install Antennas With One Connector (optional)

You can optionally use an external antenna setup with your AP300 if the controller and APs are running System Director 3.6.1MR4 or 4.0.

When deploying an AP300 with only one antenna per radio, AP300 cannot support 802.11n MIMO operation. Also, any antenna ports that are not used to connect to an antenna must be terminated with 50 ohm Reverse Polarity SMA terminators. (For a list of approved terminators, see <http://www.merunetworks.com/merusupport>.) Connect the antenna using one cable per radio as described in the table below. These instructions can be used to replace an AP200 existing antenna configuration with an AP300. For these instructions, each port on the AP300 is identified by a label A1 to A6.

Install the AP300

**AP Has One BG or A Radio, One Antenna**



**AP Has Two Radios (BG and A), One Antenna For Each**

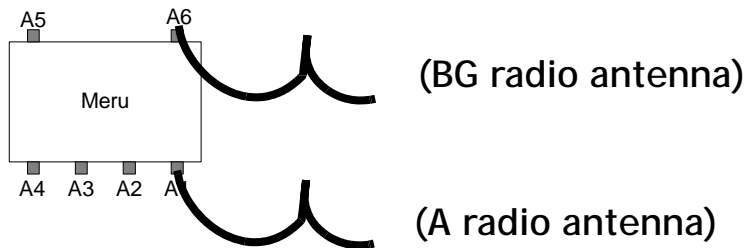

**AP Has One Radio, Two Antennas**

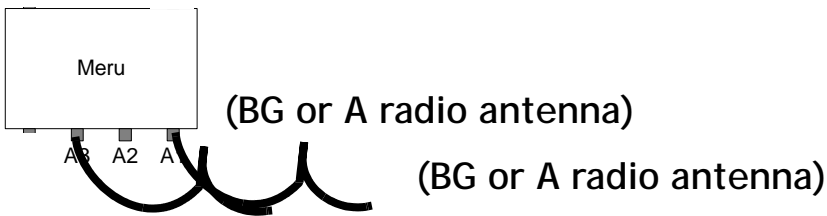

**AP Has Two Radios, Four Antennas**

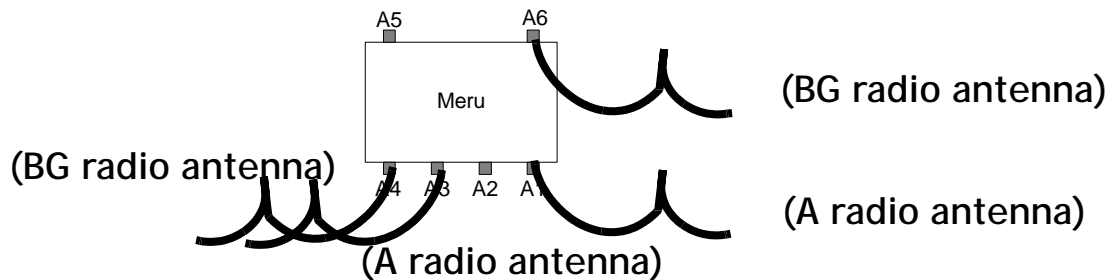



## Install the Access Point

AP300 ships with a detachable mounting bracket. The AP300 is designed to be compatible with brackets supplied by Meru and by other vendors as follows. The AP300 mounts directly on the AP150 mounting bracket. If you are replacing AP200s/AP300s, the AP300 bracket can be mounted on the old AP200s/AP300s bracket with included shoulder screws; you don't need to remove the old brackets. AP300 can also be directly mounted on third-party brackets such as Proxim AP4000 and Cisco standard brackets.

You can mount an AP300 in the following ways:

- [Mount AP300 Horizontally on a Shelf](#)
- [Mount AP300 Vertically on a Wall](#)
- [Mount AP300 Below a Suspended Ceiling](#)
- [Mount AP300 Above a Suspended Ceiling \(Plenum\)](#)
- [Mount AP300 Above a Suspended Ceiling \(Plenum\)](#)
- [Mount AP300 in a Hoffman Enclosure](#)

### Mount AP300 Horizontally on a Shelf

When mounting an AP300 horizontally, remove the mounting bracket. Be sure to position the antennas vertically when an AP300 sits on a surface.

### Mount AP300 Vertically on a Wall

 **Note:** If you are replacing AP150s, you can use the existing brackets: the AP150 and AP300 use the same bracket. If you are replacing AP300s, the AP300 bracket can be attached to the old bracket with included shoulder screws; you don't have to remove the old brackets. This bracket will also mount seamlessly into the Proxim AP4000 bracket and standard Cisco brackets.

To mount an AP300 on a wall:

1. Using the bracket holes as a guide, mark the location on the wall for the two AP bracket mounting screws. If possible, center the mounting screws on a wall stud. If you do not center the mounting screws on a wall stud, use plastic wall anchors. Orient the AP300 horizontally so that you can read the Meru logo without tilting your head at 90 degrees - this orientation provides optimum MIMO performance.
2. Drill holes at the locations you marked:
  - 3/16-inch holes if you are using plastic anchors
  - 1/8-inch holes if you are using only the screws
3. If you are using plastic anchors, install them in the holes.
4. Screw in the screws most of the way.
5. Mount the bracket on the screws, placing the circular portion of the keyhole mounts over the screw heads and sliding the bracket down.
6. Connect one end of the Ethernet cable to the switch and the other end to the AP300 Ethernet port.

Install the AP300

**!** **Caution!** Be sure to connect the Ethernet cable to the Ethernet port; the cable can mistakenly be plugged into the Console port. If you do this, the AP won't power up.

- If you are not using a PoE device, connect an external power supply to the power connector and plug it into the wall.

## Mount AP300 Below a Suspended Ceiling

The optional suspended ceiling mounting kit (ACC-MNT-SCRMKIT) allows the AP300 mounting bracket to attach to suspended ceiling T-rails (see [Figure 9](#)).

**✓** **Note:** To comply with NEC code, attach a grounding wire to any of the screws used to attach the AP300 to the mounting bracket.

Figure 9: Mounting any AP to a Suspended Ceiling Rail using ACC-MNT-SCRMKIT

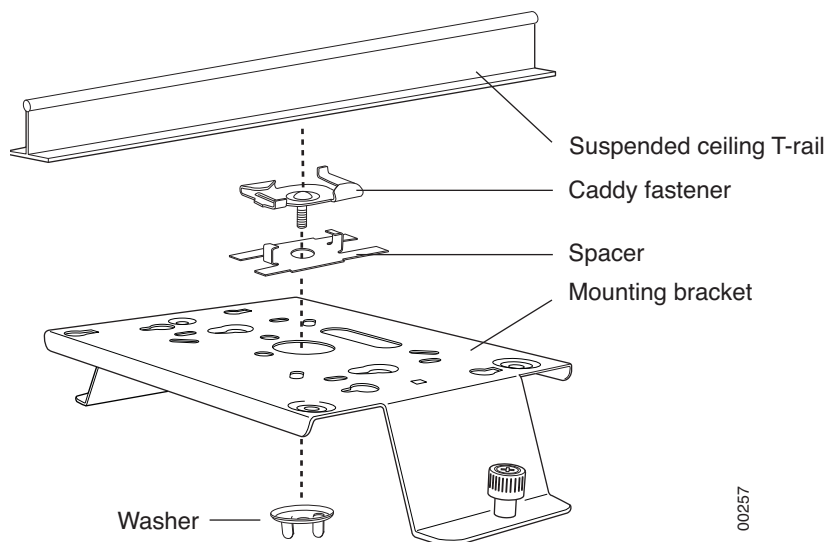

To mount an AP300 below a suspended ceiling:

- Determine the location on the ceiling rail where the AP will be mounted and remove the ceiling tiles.
- Place each of the two caddy fasteners on the ceiling T-rail and twist to attach to the rail.
- Adjust the distance between the caddy fasteners by using the mounting bracket holes as a guide.
- Tighten the caddy fasteners in place using a standard screwdriver. Do not overtighten.
- Place each spacer on the caddy fastener stud. The spacer legs should contact the ceiling T-rail.
- Align the mounting bracket keyholes with the caddy fastener studs and slide the AP300 to the narrow end of the hole.
- Attach a keps nut to each caddy fastener stud and hand tighten. Do not overtighten.

8. Align the AP300 mounting posts over the circular portion of the keyhole mounts, push the AP in and slide the AP down until it engages with the locking detents (see [Figure 9](#)). You should hear it snap in place.
9. For each antenna, loosen the knurled ring at the base of the antenna, orient the antenna and then retighten the ring.
10. Connect one end of the PoE 100BaseT Ethernet cable to the 100/1000 Ethernet connector.



**Caution!** Be sure to connect the Ethernet cable to the Ethernet port; the cable can mistakenly be plugged into the Console port. If you do this, the AP won't power up.

Install the AP300

## Mount AP300 Above a Suspended Ceiling (Plenum)

Use the optional T-bar box hanger mounting kit (see [Mounting Brackets](#) for the part number) to mount AP300 above suspended ceiling T-rails (see [Figure 10](#) and [Figure 11](#)). The installation attaches the T-bar box hanger to the ceiling rails and then the AP300 attaches to the T-bar box hanger. We recommend that you mount the AP300 no more than half way up the supports as shown in both [Figure 10](#) and [Figure 11](#). Also note that AP300 mounted above the ceiling has about 2-3 dBm less RF coverage than AP300 mounted under the ceiling.

Figure 10: AP300 Mounted Above a Suspended Ceiling Face Down

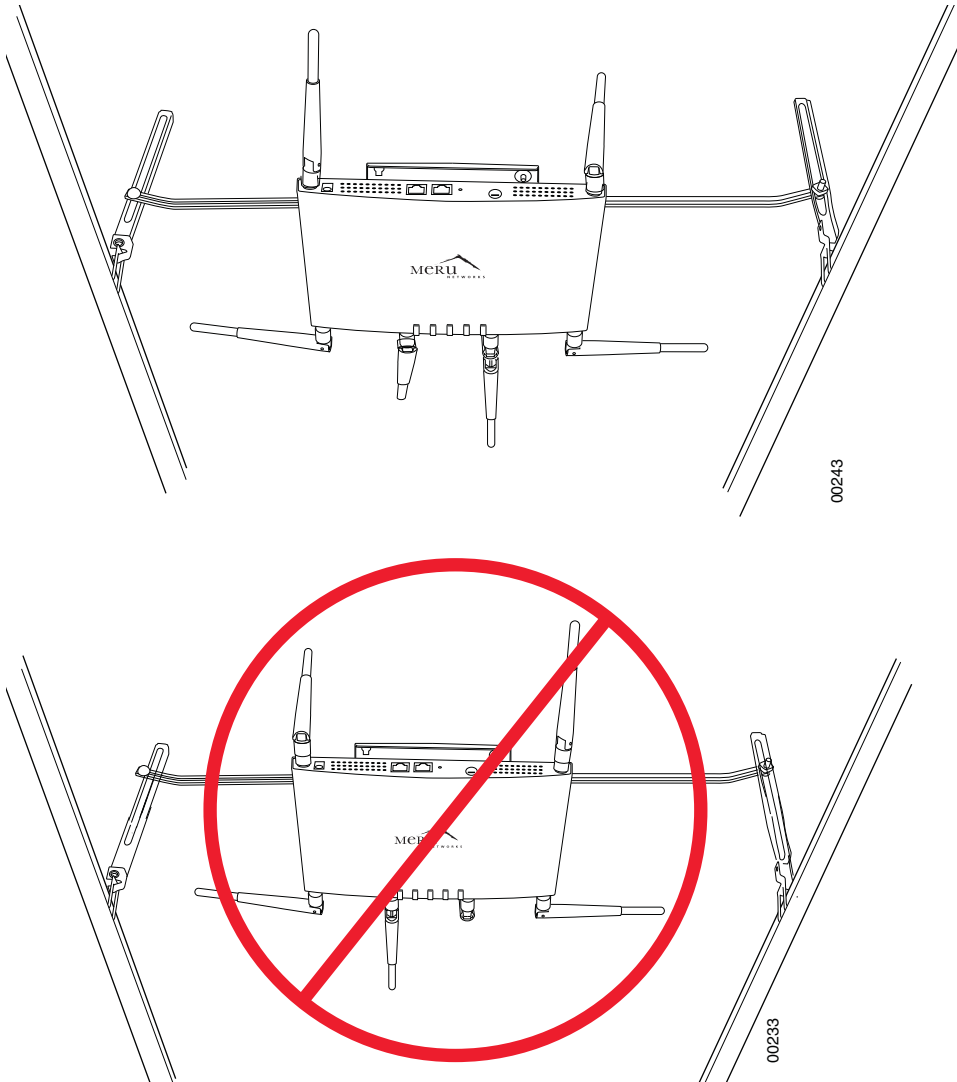

The second example above is mounted too high on the support rails, which could cause the rails to bend.

Figure 11: AP300 Mounted Above a Suspended Ceiling Face Up

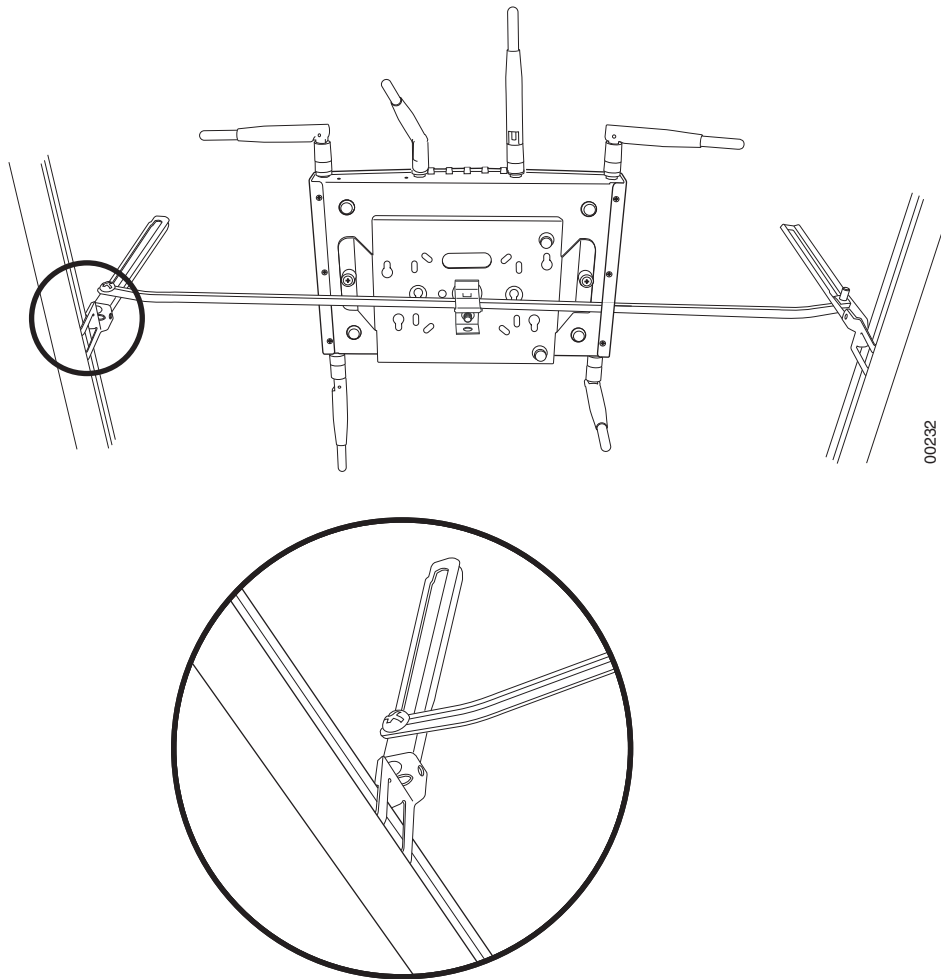

The AP300 with the metal enclosure exposed meets the requirements for fire resistance and low smoke-generating characteristics required by Section 300-22(C) of the National Electrical Code (NEC) for installation in a building's environmental air space.

You may need to modify thicker tiles to support this installation.



**Warning!** When installed in air-handling spaces, such as above a suspended ceiling, power the AP300 only with a PoE, not a power supply. See [Power Supplies](#) for part numbers.



**Warning!** Any Fast Ethernet (FE) cables installed in air-handling spaces should be suitable under NEC Article 800.50 and marked accordingly for use in plenums and air-handling spaces with regard to smoke propagation, such as CL2-P, CL3-P, MPP (Multi Purpose Plenum), or CMP (Communications Plenum). Use Ethernet cable that meets the requirements for operating in plenums and environmental air space in accordance with Section 300-22(C) of the NEC.

## Install the AP300

To mount an AP300 above the ceiling with the optional T-bar kit, follow these steps:

1. Determine the location on the ceiling rails where the AP will be mounted and remove the ceiling tile.
2. Unpack the T-bar hanger kit and unfold the legs of the T-bar hanger.
3. Locate the bracket mounting clip holes on the mounting bracket (see [Figure 10](#)). One hole attaches the bracket perpendicular to the box hanger; the other mounts the bracket parallel to the box hanger.
4. Attach the U-joint of the clip to the T-bar and snap in place (see [Figure 12](#)).

Figure 12: Attaching the Mounting Bracket to the Box Hanger for Face Up Orientation

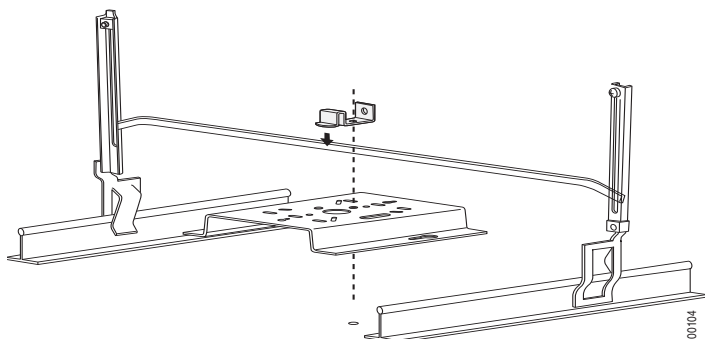
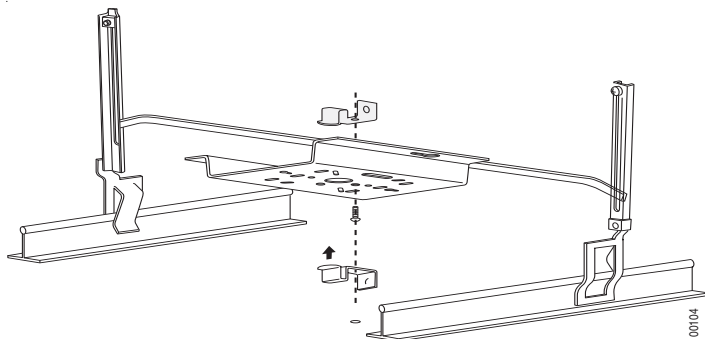

Figure 13: Attaching the Mounting Bracket to the Box Hanger for Face Down Orientation



5. Pass the long end clip through the large center hole to the underside of the mounting bracket clip and then attach the bracket to the clip using the supplied screw (see [Figure 12](#) for orientation).

6. Hold the AP300 next to the mounting bracket to estimate the height of the T-bar box hanger. You need to provide enough clearance for the external antennas that point down, while mounting the T-bar on the lower half of the support rails for stability.
7. Adjust the height of the box hanger using the height adjusting screws (see [Figure 9](#)).
8. Clip the box hanger T-rail clips to the ceiling rails, making sure they are securely attached.
9. Connect a drop wire to a building structural element and through the hole provided in the bracket mounting clip. The U.S. National Electrical Safety Code requires this additional support.
10. Connect the posts of the AP300 to the three keyholes of the mounting bracket and slide into the keyhole, ensuring the locking detent is engaged. You will hear a click.
11. For each antenna, loosen the knurled ring at the base of the antenna, point the antenna down, then retighten the ring.
12. Connect one end of the PoE Ethernet cable to the Ethernet connector.



**Caution!** Be sure to connect the Ethernet cable to the Ethernet port; the cable can mistakenly be plugged into the Console port. If you do this, the AP won't power up.



**Note:** Use a shielded Cat 5e (or greater) Ethernet cable in order to comply with international electromagnetic emissions limits.

13. Check that the AP300 is operating correctly before replacing the ceiling tile to the ceiling. Verify correct operating using the LEDs, as shown in [Check AP300 LED Activity](#).

## Mount AP300 in a Hoffman Enclosure

Meru has designed a custom mounting bracket compatible with a Hoffman enclosure ([www.hoffmanonline.com](http://www.hoffmanonline.com)). This bracket is available exclusively through Meru and orderable as part number ACC-AP300-BHE. To mount an AP300 in a Hoffman enclosure, follow these steps:

1. Place AP300 upside down on a soft flat surface.
2. Remove and discard the wall/ceiling mounting bracket.
3. Attach either the provided antennas or an external antenna.
4. Remove and discard the four rubber feet.
5. Position the Hoffman bracket (ACC-AP300-BHE) onto the back of the AP300 with the four Hoffman mounting screws facing downwards.

## Check AP300 LED Activity

Figure 14: Hoffman Bracket ACC-AP300-BHE

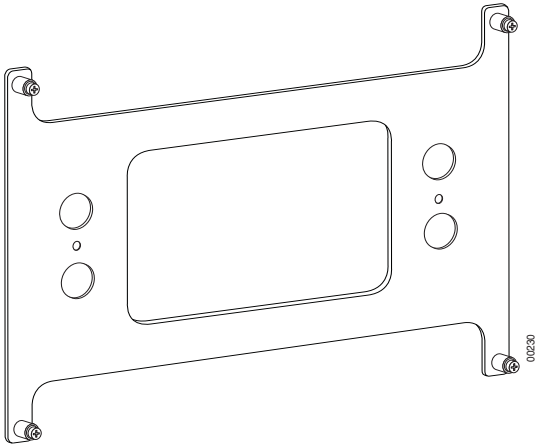

6. Using a Phillips screw driver, attach the bracket using the two supplied 6-32 3/16 SEMS screws.
7. Flip the assembly over and mount into the Hoffman enclosure, attach the Ethernet cable to the AP300 rotating the assembly to place the Ethernet cable within the enclosure.
8. Using a Phillips screw driver, tighten the four bracket screws to the enclosure.
9. Adjust the antennas as needed.

## Check AP300 LED Activity

When AP300 first connects to the controller (and any time the access point is rebooted), the AP initializes and is then programmed by the controller. When the AP first powers up, all LEDs are green.

Figure 15: AP300 Status LEDs

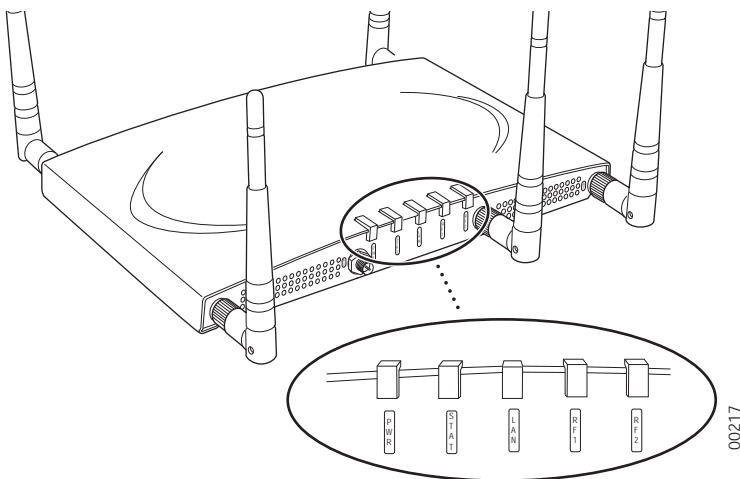

After the AP300 is connected, check the status of the LEDs. The functions of the five LEDs are described below.



## AP300/AP300i LED Descriptions

LED	Function	Troubleshooting
Power	off—no power green—presence of power	
Status	off—no power green—booting stage 1 blinking green and off—booting stage 2 blinking green and white—discovering the controller blinking green and blue—downloading a configuration from the controller blinking blue and off—AP is online and enabled, working state blinking red and yellow—failure; consult controller for alarm state	If the status LED is blinking red and yellow, there is an alarm on the AP. Determine what the alarm is by clicking <b>Monitor &gt; Dashboard &gt; Alarms</b> and looking at the AP alarms. You can also use the CLI commands <b>show alarm</b> and <b>show log</b> .
LAN	off—no power or no link green—link status OK (at any speed) green/blinking—activity (at any speed) red—auto negotiation failure	If the LAN LED is red, auto negotiation failed. This means that you have a problem with cabling or with the AP's switch.
Radio 1 Radio 2	off—no radio present green—radio enabled green blinking—data activity yellow—disabled or in scanning mode red—failure	If one of the radio LEDs is yellow, it is either disabled or in scanning mode. To see if the AP is disabled, click <b>Configuration &gt; Wireless &gt; Radio &gt;</b> select a radio and then look at Administrative Status, which should be set to <b>Up</b> . To see if the AP is in Scanning Mode, click <b>Configuration &gt; Wireless &gt; Radio &gt;</b> select a radio and look at AP Modes, which should be set to <b>Normal Mode</b> .  If one of the radio LEDs is red, the radio failed. Check the alarms ( <b>Monitor &gt; Dashboard &gt; Alarms</b> ), diagnostics ( <b>Monitor &gt; Diagnostics &gt; Radio</b> ), and statistics ( <b>Monitor &gt; Dashboard &gt; Radio</b> ) on the AP's controller to determine the cause.

Where to Go From Here

## Change LED Appearance

If you want to change the appearance of the LEDs, follow these steps:

1. From the controller, click **Configuration > Devices > AP**, and then select the AP.
2. Select one of these settings for the LED Mode setting:
  - **Normal:** LEDs are as described below
  - **Node ID:** Not supported in release 4.1
  - **Blink:** Sets all LEDs flashing; this is useful to locate an AP
  - **Dark:** Turns off all LEDs
3. Click **OK**.

## Where to Go From Here

---

Now that the AP1000 is installed, refer to the *Meru System Director Getting Started Guide* for instructions on initializing the hardware. Return to this chapter to check the status of the LEDs once the WLAN is operational.

Where to Go From Here

## Change LED Appearance

If you want to change the appearance of the LEDs, follow these steps:

1. From the controller, click **Configuration > Devices > AP**, and then select the AP.
2. Select one of these settings for the LED Mode setting:
  - **Normal:** LEDs are as described below
  - **Node ID:** Not supported in release 4.1
  - **Blink:** Sets all LEDs flashing; this is useful to locate an AP
  - **Dark:** Turns off all LEDs
3. Click **OK**.

## Where to Go From Here

---

Now that the AP1000 is installed, refer to the *Meru System Director Getting Started Guide* for instructions on initializing the hardware. Return to this chapter to check the status of the LEDs once the WLAN is operational.

### FCC Regulations:

● This device complies with part 15 of the FCC Rules. Operation is subject to the following two conditions: (1) This device may not cause harmful interference, and (2) this device must accept any interference received, including interference that may cause undesired operation.

● This device has been tested and found to comply with the limits for a Class B digital device, pursuant to Part 15 of the FCC Rules. These limits are designed to provide reasonable protection against harmful interference in a residential installation. This equipment generates, uses and can radiate radio frequency energy and, if not installed and used in accordance with the instructions, may cause harmful interference to radio communications. However, there is no guarantee that interference will not occur in a particular installation. If this equipment does cause harmful interference to radio or television reception, which can be determined by turning the equipment off and on, the user is encouraged to try to correct the interference by one or more of the following measures:

- Reorient or relocate the receiving antenna.
- Increase the separation between the equipment and receiver.
- Connect the equipment into an outlet on a circuit different from that to which the receiver is connected.
- Consult the dealer or an experienced radio/TV technician for help.

Changes or modifications not expressly approved by the party responsible for compliance could void the user's authority to operate the equipment.

● This device complies with FCC radiation exposure limits set forth for an uncontrolled environment. In order to avoid the possibility of exceeding the FCC radio frequency exposure limits, human proximity to the antenna shall not be less than 20cm (8 inches) during normal operation.

● Operation on the 5.15-5.25GHz frequency band is restricted to indoor use only. The FCC requires indoor use for the 5.15-5.25GHz band to reduce the potential for harmful interference to co-channel Mobile Satellite Systems. Therefore, it will only transmit on the 5.25-5.35 GHz, 5.47-5.725 GHz and 5.725 – 5.85 GHz band when associated with an access point (AP).

● The antenna(s) used for this transmitter must not be co-located or operating in conjunction with any other antenna or transmitter.

Operation is subject to the following two conditions: (1) this device may not cause interference, and (2) this device must accept any interference, including interference that may cause undesired operation of the device.

This Class B digital apparatus complies with Canadian ICES-003.  
Cet appareil numérique de la classe B est conforme à la norme NMB-003 du Canada.

The device for the band 5150-5250 MHz is only for indoor usage to reduce potential for harmful interference to co-channel mobile satellite systems; the maximum antenna gain permitted (for devices in the band 5725-5850 MHz) to comply with the e.i.r.p. limits specified for point-to-point and non point-to-point operation as appropriate, as stated in section A9.2(3). In addition, High-power radars are allocated as primary users (meaning they have priority) and this radar could cause interference and/or damage to LE-LAN devices.

This device and its antenna(s) must not be co-located or operating in conjunction with any other antenna or transmitter.

The County Code Selection feature is disabled for products marketed in the US/Canada. For product available in the USA/ Canada markets, only channel 1-11 can be operated. Selection of other channels is not possible.

### IMPORTANT NOTE:

#### IC Radiation Exposure Statement

This equipment complies with IC RSS-102 radiation exposure limits set forth for an uncontrolled environment. This equipment should be installed and operated with minimum distance 20cm between the radiator & your body.