

**OPERATION  
OF THE  
MCC-6120 SDR  
PACKET DATA RADIO**

MAN-OPS-6120 SDR-ARR

***PRELIMINARY***

January 16, 2007

Meteor Communications Corporation  
22614 66<sup>th</sup> Avenue South.  
Kent, WA 98032  
Tel: (253) 872-2521  
Fax: (253) 872-7662  
E-mail: [mcc@meteorcomm.com](mailto:mcc@meteorcomm.com)  
On the Web: [www.meteorcomm.com](http://www.meteorcomm.com)



## GENERAL WARRANTY

*Meteor Communications Corporation (MCC)* warrants that its products conform to the published specifications and are free from manufacturing and material defects for one year after shipment. Warranty-covered equipment that fails during the warranty period will be promptly repaired at MCC's facility in Kent, Washington.

International customers are required to pay shipping costs to the MCC facility, with Seattle as the point of U.S. entry. MCC will pay incoming U.S. duty fees. MCC will pay for shipping costs to return the equipment to the customer, with the customer paying any and all return duty fees.

This warranty is contingent upon proper use of the equipment and does not cover equipment that has been modified in any way without MCC's approval or has been subjected to unusual physical or electrical stress, or on which the original identification marks have been removed or altered.

---

---

**Important Safety Instructions for Installers and Users  
RF Exposure Information**

In order to comply with Federal Communications Commission safety standards for human exposure to radio frequency (RF) energy, the following precautions must be taken.

**1. MOBILE ANTENNA INSTALLATION**

- The following instructions apply to antenna mounting on metal-body vehicles or those equipped with a suitable ground plane.
- Mount antennas in the following areas:
  - The center of the roof of the vehicle or,
  - The center of the trunk lid of the vehicle, provided the Minimum Separation Distance (see chart below) between the antenna and rear seat passengers is maintained.

Frequency Band	Antenna type	maximum duty cycle	Minimum Separation Distance	
			cm	in
39 - 50 MHz	1/4 wave dipole mounted to roof or trunk lid of vehicle	15.00%	109.2	43.0
151 - 162 MHz	1/4 wave dipole mounted to roof or trunk lid of vehicle	50.00%	114.3	45.0
896-901MHz/935-940 MHz	1/4 wave dipole mounted to roof or trunk lid of vehicle	50.00%	63.5	25.0
896-901MHz/935-940 MHz	5/8 wave over 1/4 wave colinear mounted to roof or trunk lid of vehicle	50.00%	88.9	35.0
2412 - 2462 MHz	3 dBi omnidirectional	100.00%	20	7.9

- Install all antennas in accordance with manufacturer’s instructions.
- Always disable the transmitter when installing or servicing an antenna or transmission line or when working near and installed antenna.

**Important Safety Instructions for Installers and Users**  
**RF Exposure Information**

In order to comply with Federal Communications Commission safety standards for human exposure to radio frequency (RF) energy, the following precautions must be taken.

**2. MOBILE OPERATION**

- The user should be fully trained in the operation of the radio, including factors that influence RF exposure, such as the proximity of people to an antenna during transmission times.
- Do not operate the voice-enabled transmitters more than 50% of the time.
- Operate the voice-enabled transmitters only when people outside of the vehicle are located at least the Minimum Separation Distance from the transmitting antenna.

When these precautions are taken, an installation with this device satisfies the FCC requirements for RF Exposure.

**3. BASE INSTALLATION**

- Base antennas should be installed on permanent outdoor structures. RF Exposure compliance at such sites must be addressed on a site-by-site basis.



**TABLE OF CONTENTS**

<b>Title</b>	<b>Page</b>
1.0 INTRODUCTION .....	1-1
1.1 Manual Organization .....	1-2
1.2 Related Documents .....	1-3
2.0 DESCRIPTION.....	2-4
2.1 General.....	2-4
2.2 Functionality Overview .....	2-5
2.3 SDR Modules.....	2-9
2.4 Detailed Specifications .....	2-9
2.5 Memory Organization.....	2-12
3.0 INSTALLATION .....	3-1
3.1 Site Selection .....	3-1
3.1.1 External Noise/Interference .....	3-1
3.1.2 DC Power Source.....	3-2
3.1.3 Antenna Selection .....	3-3
3.1.4 Antenna Height .....	3-3
3.2 Equipment Installation .....	3-5
3.2.1 Mobile Installations .....	3-5
3.2.2 Cable Connections .....	3-5
3.2.2.1 DC Power Input.....	3-6
3.2.2.2 LB/HB Connectors.....	3-7
3.2.2.3 GPS Antenna.....	3-7
3.2.2.4 802.11(b).....	3-7
3.2.2.5 I/O Port.....	3-7
3.2.2.6 Ethernet/USB Connector.....	3-11
3.3 Power-Up Sequence.....	3-13
3.3.1 Connect Operator Terminal .....	3-13
3.3.2 Power Connection.....	3-13
3.3.3 Initialization Procedures .....	3-14
3.3.3.1 Verify Device Type.....	3-14
3.3.3.2 Verify ID Number .....	3-15
3.3.3.3 Verify Channel Frequency .....	3-15
3.3.3.4 Select Site Name .....	3-16
3.3.3.5 Enter Script Files.....	3-16
3.4 Operational Test Procedure.....	3-18
3.4.1 RF Test.....	3-18

**LIST OF FIGURES**

<b>Figure</b>		<b>Page</b>
1.0	Typical Network .....	1-1
2.1-1	MCC-6120 SDR Photograph .....	2-1
2.2-1	MCC-6120 SDR Radio .....	2-2

**LIST OF TABLES**

<b>Table</b>		<b>Page</b>
2.1	MCC-6120 SDR General Specifications .....	2-9
2.2	MCC-6120 SDR Low Band Receiver Specifications .....	2-10
2.3	MCC-6120 SDR Low Band Transmitter Specifications .....	2-10
2.4	MCC-6120 SDR High Band Receiver Specifications .....	2-11
2.5	MCC-6120 SDR High Band Transmitter Specifications .....	2-11
2.6	MCC-6120 SDR Microprocessor Specifications .....	2-12

**CONVENTIONS**

The following conventions are used in this manual:

When presented in the text, user commands and computer printout are boldfaced; e.g., Enter **DELETE**. Command parameters are presented in lower case; e.g., **DEFINE**,id. Optional parameters are enclosed in brackets; e.g., **TIME**{,hh:mm:ss}

Names of terminal keys are capitalized and enclosed in square brackets when mentioned in the text; e.g., Press [ESC].

Names of hardware switches, meters, etc. are capitalized; e.g., PWR ON switch.

<p style="text-align: center;"><b>NOTE</b> Used for special emphasis of material</p>
--

<p style="text-align: center;"><b>IMPORTANT</b> Used for added emphasis of material</p>
---

<p style="text-align: center;"><b>CAUTION</b> Cautions the operator to proceed carefully</p>
--

<p style="text-align: center;"><b>WARNING! WARNING! WARNING!</b> Used in cases where failure to heed the message may result in personal injury or equipment damage.</p>
---



## ACRONYMS AND ABBREVIATIONS

<b>A/D</b>	Analog-to-Digital
<b>ACK</b>	Acknowledgement
<b>ADC</b>	Analog-to-Digital Converter
<b>AP</b>	Access Point
<b>AUX</b>	Auxiliary Port
<b>AVL</b>	Automatic Vehicle Location
<b>BPSK</b>	Binary Phase Shift Keying
<b>CIM</b>	Configuration Information Module
<b>CMU</b>	Communications Management Unit
<b>CR</b>	Carriage Return
<b>CSMA</b>	Carrier Sense Multiple Access
<b>DAC</b>	Digital-to-Analog Converter
<b>DMC</b>	Data, Management and Control
<b>DGPS</b>	Differential GPS
<b>DHCP</b>	Dynamic Host Configuration Protocol
<b>DSP</b>	Digital Signal Processing
<b>DTA</b>	Data Port
<b>EAP-TLS</b>	Extensible Authentication Protocol – Transport Layer Security
<b>EEPROM</b>	Electrically Erasable Programmable Read Only Memory
<b>ELOS</b>	Extended-Line-of-Sight
<b>ETE</b>	End-to-End Acknowledgement
<b>FEC</b>	Forward Error Correction
<b>FLASH RAM</b>	Nonvolatile Memory (faster than EEPROM)
<b>GMSK</b>	Gaussian Minimum Shift Keying
<b>GPS</b>	Global Positioning System
<b>HPI</b>	Host Port Interface
<b>KBPS</b>	Kilo (1,000) bits per seconds
<b>LAN</b>	Local Area Network
<b>LED</b>	Light Emitting Diode
<b>LOS</b>	Line-of-Sight
<b>MBC</b>	Meteor Burst Communication
<b>MBCS</b>	Meteor Burst Communication System
<b>MCC</b>	Meteor Communications Corporation
<b>MNT</b>	Maintenance Port

<b>MPL</b>	Modem Programming Language
<b>MSC</b>	Master Station Control Protocol
<b>NAT</b>	Network Address Translation
<b>NAPT</b>	Network Address Port Translation
<b>NMEA</b>	National Marine Electronic Association
<b>PC</b>	Personal Computer
<b>RAM</b>	Random Access Memory
<b>RF</b>	Radio Frequency
<b>RTCM</b>	Radio Technical Commission for Maritime Services
<b>RTOS</b>	Real-Time Operating System
<b>RX</b>	Receive
<b>SCADA</b>	Supervisory Control and Data Acquisition
<b>SDATA</b>	Sensor Data
<b>SDR</b>	Software Defined Radio
<b>SMX</b>	RTOS for ColdFire Processor
<b>SNP</b>	System Network Parameter
<b>SPDT</b>	Single Pole Double Throw
<b>TCP</b>	Transmission Control Protocol
<b>TCP/IP</b>	Transmission Control Protocol/Internet Protocol
<b>TDMA</b>	Time Division Multiple Access
<b>TELNET</b>	Terminal Emulation Program for TCP/IP Networks
<b>TX</b>	Transmit
<b>UPDT</b>	Update
<b>USB</b>	Universal Serial Bus
<b>UTC</b>	Universal Time Clock
<b>VSWR</b>	Voltage Standing Wave Ratio
<b>WEP KEY</b>	Wired Equivalent Privacy Key
<b>WIFI</b>	IEEE 802.11-based Wireless Local Area Network
<b>WLAN</b>	Wireless Local Area Network
<b>WPA</b>	WIFI Protected Access
<b>XTERMW</b>	Terminal Emulator for Windows

# 1.0 INTRODUCTION

The MCC-6120 SDR PACKET DATA RADIO is used in MCC’s Network. This is an Extended Line-of-Sight (ELOS), packet switched, digital data network that operates on a single frequency in the low VHF band (40-50 MHz), a high VHF band (151-162 MHz), or a UHF band (896-901/935-940 MHz). A network has a cellular structure that uses the programmable MCC-6120 SDR as a base station, a repeater and as a remote station. One or more Data Centers are normally used for the central collection and distribution of data to a customer’s office. The network can be as small as one base station or may be comprised of thousands of base stations, repeaters and remote stations. The networks are used for position reporting in mobile applications (AVL), fixed site data collection (SCADA) and messaging.

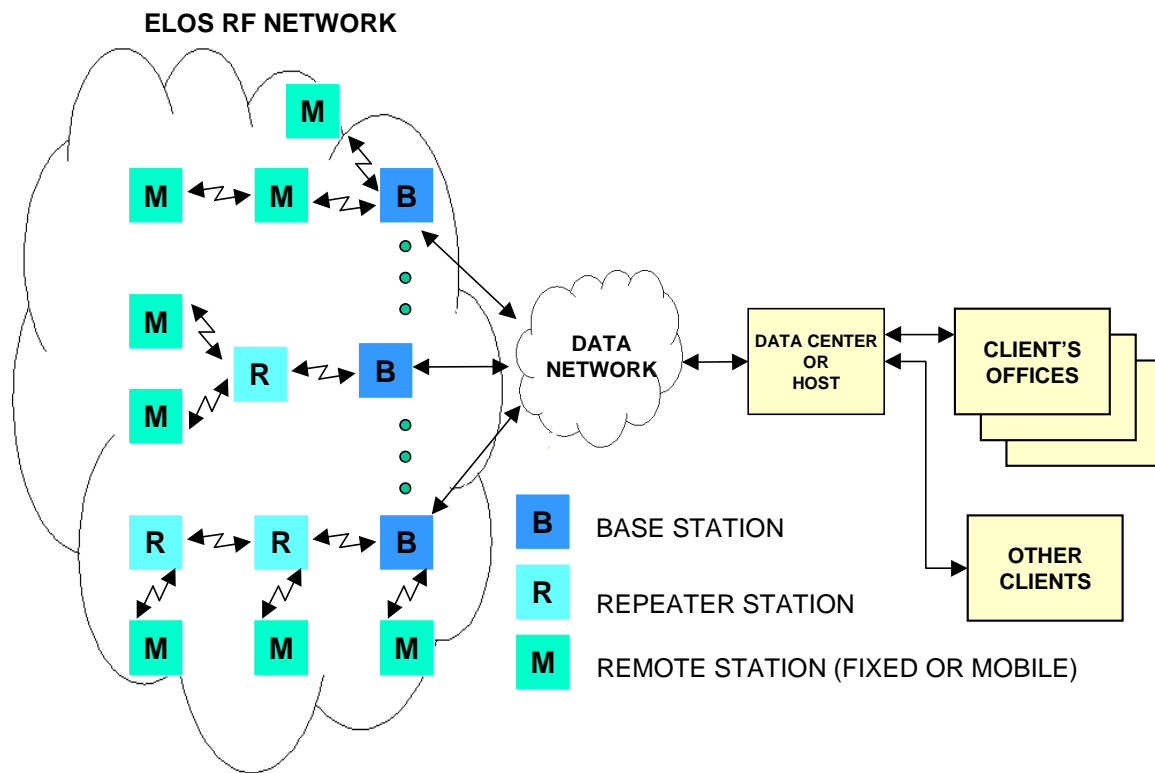

**TYPICAL NETWORK**  
**FIGURE 1.0**

The MCC-6120 SDR can be dynamically programmed to operate in three distinct modes: (1) as a base station, (2) a repeater station, or (3) as a remote station. As a base station it is connected to a Data Center or Host through a Data Network. The Data Network can be frame relay, microwave, the Internet or other forms of existing infrastructure. The MCC-6120 SDR has two Ethernet (10MHz) network interface adaptors. If a direct connection is not available the MCC-6120 SDR operates as a repeater into the nearest base station. Multiple repeater links may be chained together for expansion of the network when no other communication infrastructure is available. In addition the unit has an 802.11(b) network adaptor that can be used to connect to

802.11(b) access points in the infrastructure mode, or to other 802.11(b) devices in an add-hoc mode.

As a remote station it can operate as a mobile unit roaming throughout the entire network, automatically linking with the nearest base station or repeater. When a remote station is installed at a fixed site it also links itself automatically to the nearest base station or repeater.

The MCC-6120 SDR operates line-of-sight using groundwave. The range of communication by groundwave is primarily determined by diffraction around the curvature of the earth, atmospheric diffraction and tropospheric propagation. These ranges are successfully extended by MCC through the use of robust protocols, sensitive receivers, 100 watt transmitters (low band) or 30 watt transmitters (high band), and short packetized messages. MBNET200 is the operating system that successfully integrates these features, providing error-free communication throughout the network at ranges from 25-50 miles.

The network protocol embedded within the MCC-6120 SDR uses a combination of both carrier sense multiple access (CSMA) and time division multiple access (TDMA) for achieving a channel utilization rate greater than 90%.

The MCC-6120 SDR uses GMSK modulation and has selectable data rates of 4.8 Kbps, 9.6Kbps and 19.2Kbps. Data rates and modulation filtering are limited by internal software to values that have been type accepted by the FCC for the particular frequency band selected. This prevents transmitting on an unauthorized frequency or modulation format.

The MCC-6120 SDR has an embedded 32-bit controller for managing all the network functions associated with a packet switched data network and for interfacing to a variety of peripheral devices. In addition, it has a built-in test capability that automatically monitors the operating integrity of the unit at all times. This feature also eliminates the need for any special test equipment during the installation phase. A laptop, or equivalent, is required to initialize and operate the MCC-6120 SDR packet radio.

## **1.1 Manual Organization**

There are three major sections in this manual, plus a number of appendices:

### Section 2.0 DESCRIPTION

This section provides both a physical description and a functional description of each module in the MCC-6120 SDR. The detailed technical specifications are provided for each printed circuit board assembly (PCA), as well as the organization of the unit's computer memory.

### Section 3.0 INSTALLATION

This section covers site selection and general installation guidelines, including instructions for cabling, antenna and power source connections. Power up procedures, initialization and

functional test procedures are described that should be performed prior to placing the MCC-6120 SDR on-line within the network.

## **1.2 Related Documents**

Additional documents and application notes that may be helpful in the operation of the MCC-6120 SDR Packet Radio in an ELOS Network are given below. They can be obtained from MCC or downloaded from MCC's web site, [www.meteorcomm.com](http://www.meteorcomm.com).

- 1.2.1 MBNET 200  
A Complete List of all Commands and Printouts
- 1.2.2 DMC  
Data Monitor and Control, DMC 6.338, Users Manual, December 22, 2005
- 1.2.3 XTERMW  
Operation of the XTERMW Terminal Emulation Program for Windows, April 2, 2001
- 1.2.4 FleetTrak™  
Network Performance and System Capacity, EDT 11037, March 9, 1999
- 1.2.5 MPL  
Modem Programming Language Users Manual, September 26, 2004
- 1.2.6 Related Application Notes:
  - MCC-545 Event Programming, March 5, 2003
  - CIM management with Password Protect Mode, April 1, 2003
  - MSC2 Protocol Interface Control Document, January 31, 2005
  - CR10X Data Acquisition, January 25, 2000

## **2.0 DESCRIPTION**

### **2.1 General**

The MCC-6120 SDR Packet Data Radio provides packet switched communications from fixed or mobile sites to a central Host. It can be used for sending and receiving messages, position reporting, data logging, or other custom applications.

The unit is packaged in a stainless steel, weather-resistant enclosure that measures 9.5”L X 4.0”W X 4.3” H and weighs 6.0 pounds.

A photograph of the MCC-6120 SDR is given in Figure 2.1-1.



**MCC-6120 SDR PHOTOGRAPH  
FIGURE 2.1-1**

## 2.2 Functionality Overview

### Introduction

The MCC-6120 SDR is the next step in the evolution of the MCC family of Packet Data Radios. The necessity for providing customers with simple, yet powerful, fixed and mobile communications capabilities has led to the development of a Software Defined Radio (SDR) coupled to a Communications Management Unit (CMU). The previous design, known as the MCC-545C, used a 20 MHz Motorola 68332 processor, 40 MHz Low-Band VHF GMSK analog receiver/DSP transmitter, and had three RS-232 serial ports for interfacing to external equipment. The MCC-6120 SDR has added additional capabilities including a 50 MHz Motorola ColdFire 5485 processor, TI Digital Signal Processor, TCP/IP stack, two Ethernet ports, an 802.11b port, two USB ports, and a second RF transceiver in the 160 MHz band.

This section will describe the type of message transport services that are provided, then describe the commands required to configure the various services.

### Message Transport Services

Figure 2.2-1 shows the CMU in relation to its ports and Low-Band Radio Link. This paragraph will discuss the ways the CMU can provide message transport services between the external applications that may be attached to the various ports.

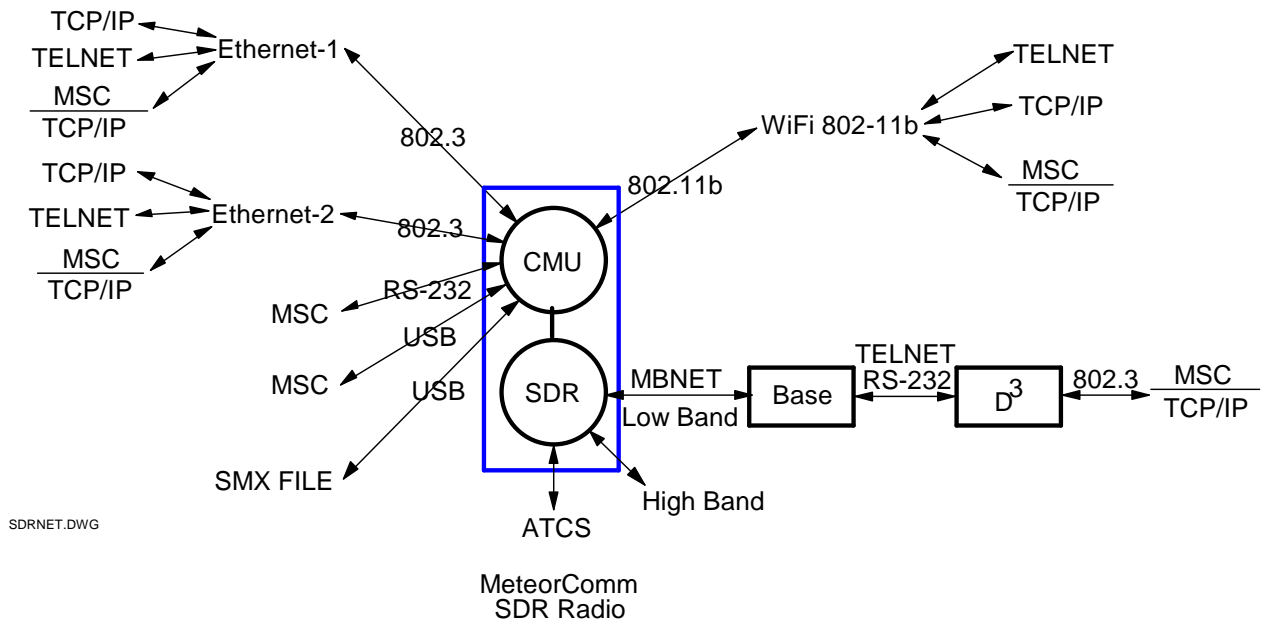

FIGURE 2.2-1

The MCC software architecture allows any of its ports to be assigned to a wide variety of device drivers. This provides a very flexible means of configuring any radio to meet particular

Customer and system requirements. New device drivers have been developed to provide this same flexibility to the Ethernet and WIFI ports. For example, a laptop, tablet or palm computer can be set up to run Xtermw.exe connected through one of the Ethernet ports or WIFI (in ad-hoc mode) to operate as the maintenance terminal. Another example is that a local host computer can connect through one of the Ethernet ports and route IP packets through the CMU and WIFI port (in Infrastructure mode) to an Access Point, and on to a WAN-based Central Host System.

### **TCP/IP**

The TCP/IP stack is a shared library that allows the Ethernet and WIFI ports to operate as traditional IP Network connections with IP-Forwarding (routing). In the MCC-545C, use of Ethernet connections was provided only by external terminal-server boxes connected to the RS-232 serial ports. Only ASCII (TELNET) and MSC or MSC2 protocols could be used for interfacing with external equipment. The MCC-6120 SDR CMU has the Ethernet and WIFI built-in, and can be directly interfaced to many Ethernet Devices using the standard “Sockets” software API.

Each Ethernet and WIFI port can be given its own IP address. The initial version of MCC-6120 SDR software allows each port to have from 1 to 4 application “ports”. These are numbered from 4000 – 4011.

### **DHCP Client**

Either Ethernet port or the WIFI port can have DHCP-Client enabled to automatically get an IP address from a DHCP server located on its subnet.

### **DHCP Server**

Either Ethernet port or the WIFI port can have DHCP-Server enabled to automatically supply an IP address to devices located on its subnet. This is a limited implementation and can only supply IP addresses, not any other configuration data options.

### **NAT**

The Network Address Translation (NAT) protocol can be configured to separate a private subnet from the public network. As the private hosts send IP packets to the public network, the NAT routing function translates the private IP addresses into public IP addresses. As packets come back from the public network, the translation is reversed and the packet delivered to the correct private IP address. Options exist for assigning static IP addresses, and defining dynamic IP addresses to be used for the translation.

### **NAPT**

The Network Address Port Translation (NAPT) protocol is similar to NAT, except a range of port numbers are defined to be used by the router in the address translation. In this way, a single private and public IP address can be used on each side of the router. The private processes are

assigned one of the port numbers out of the given port number set when they send IP packets to the public Network. Address translation happens using the public IP address and newly assigned port number.

### **ASCII (TELNET)**

The ASCII protocol is basically a dumb serial protocol transported over a TCP connection. This is useful for connections to maintenance terminals that use XTERMW.EXE as a terminal emulator.

### **MSC Protocol Suite**

The Master Station Control (MSC) protocol suite is a set of packet protocols that can be used on any RS-232 port as well as transported over any TCP connection. The suite is composed of three packet protocols that operate much like UDP, in that data is transported from source to destination without establishing an end-to-end TCP/IP connection first. The source and destination addressing uses 16-bit Radio ID's instead of IP addresses.

MSC is the original packet protocol and operates with a stop-and-wait link layer where each packet is sent by first asking permission, then sending the packet if permitted.

MSC2 is an extension of MSC. It uses the same packet-body message and command layer formats, but uses a windowing type of link layer to achieve higher throughput.

MSC3 is an extension of the command layer formats to allow MSC or MSC2 link layer connections to operate on multiple ports.

### **WIFI, AP, AD-HOC, Wireless Security**

The WIFI port (802.11b) can be set up to connect to an Access Point (AP) in Infrastructure mode, or to other WIFI devices in ad-hoc mode. The WIFI port can not operate in both modes at once. An option can set the port to AUTO mode where it will use an AP if one is in range, or else it can use an ad-hoc connection. The choice of SSID strings is user-configurable.

Once connected, the WIFI link operates like the Ethernet links with full TCP/IP capability. The host processors connected to an Ethernet port will be able to connect through the CMU and WIFI line to IP addresses on the WAN that the AP is connected to. Roaming between access points is not yet supported.

Two security options, WEP and WPA, are available (in addition to no security):

**WEP**            **Wired Equivalency Privacy** – This mode uses a password to act as an encryption key. If a 5-byte key is used, then 64-bit encryption is utilized. If a 13-byte key is used then 128-bit encryption is utilized. The WEP key is entered in hexadecimal format using only 0-9 and A-F characters. Authentication must be handled at the application level.



- WPA      **WIFI Protected Access** – This mode also uses encryption as well as authentication. There are three WPA variations supported:
- PSK      **Pre Shared Key** – A passphrase of 8-63 ASCII characters is required. The passphrase is used to generate an encryption key. This is sometimes called “WPA-Personal” (and should not be confused with different PSK modulation schemes used by the various SDR transceivers).
  - EAP-TLS      **Extensible Authentication Protocol–Transport Layer Security** – This mode uses certificates for authentication. A password (up to 32 bytes expressed in hexadecimal format) is needed to decrypt key information from the certificate. Access points are connected to a Radius server which performs authentication.
  - EAP-TTLS      **Extensible Authentication Protocol–Tunneled Transport Layer Security** – This mode uses certificates only on the server side for authentication. A password (up to 64 ASCII characters) is needed to obtain key information. Access points are connected to a Radius server which performs authentication.

**USB Ports and SMX File**

Two USB ports are provided. One port is for connecting a Flash-memory device for use as disk file storage. The SMX-file software device-driver lets application software in the CMU create, delete, read and write Flash-memory files.

The second USB port is for connecting serial devices that emulate RS-232 ports. This option is not yet available.

### **2.3 SDR Modules**

The MCC-6120 SDR contains four printed circuit board assemblies as shown in Figure 2.3-1.

- A 32-bit Communications Management Unit (CMU) microprocessor controller performs the radio control, link and network protocol functions. This assembly also contains a digital signal processor (DSP) and a digital-to-analog converter (DAC) for generating the GMSK RF signal. The DSP also receives and demodulates the receive GMSK signals on all bands.
- A 30W, 3-stage power amplifier, filters, and mixers for operation in the 151-162 MHz band
- A 100W, 3-stage power amplifier in the 39-50 MHz band.
- A 12-channel GPS receiver that can be mounted on the processor board as an optional subassembly.
- An 802.11(b) Module (15mW) mounted on the CMU board.

All components are soldered in place using surface mount technology. As an option, the boards can be conformal coated with an acrylic encapsulate that contains a tropicalizing, anti-fungal agent to provide additional protection against moisture and contamination.

### **2.4 Detailed Specifications**

The detailed specifications for each of the printed circuit board assemblies are given in Tables 2.1 through 2.6.

**MCC-6120 SDR GENERAL SPECIFICATIONS**

<b>CHARACTERISTIC</b>	<b>SPECIFICATION</b>
Dimensions	10.6”L X 4.0”W X 4.4”H
Weight	6.0 lbs.
Temperature Range	-30° to 60° C (-22° to 140° F)
Power Requirements	12 V <sub>DC</sub> Nominal (10-15 V <sub>DC</sub> ) Standby: 600 mA (Continuous) Transmit: 22 Amps Nominal (Low Band) 8 Amps Nominal (High Band)

**TABLE 2.1**

**MCC-6120 SDR LOWBAND RECEIVER SPECIFICATIONS**

CHARACTERISTIC	SPECIFICATION
Frequency	39-50 MHz .0005% DDS 1 Hz steps
Modulation: Rate Type Format	4.8kbps, 9.6 kbps, and 19.2 kbps BPSK (4.8 kbps); GMSK (9.6kbps & 19.2kbps) NRZ
Noise Figure	< 8 dB minimum
Sensitivity: Bit Error Rate < 10 <sup>-3</sup> at 9.6 kbps	-113 dBm at 9.6 kbps -110 at 19.2 kbps
IF Bandwidth (3/80 db)	13/40 kHz typical
RF Bandwidth (3 db)	13 MHz typical
Signal Acquisition Time	< 5 msec
3 <sup>rd</sup> Order Intercept Point	>- 4 dBm
Image Response Attenuation	> 70 dB minimum
Spurious Response Attenuation	> 70 dB minimum
I/O	MCC Standard (Refer to Section 3.2)

**TABLE 2.2****MCC-6120 SDR LOWBAND TRANSMITTER SPECIFICATIONS**

CHARACTERISTIC	SPECIFICATION
Frequency	39-50 MHz .0005% Synthesized 10kHz steps
RF Power Output	> 100 Watts at 12 V <sub>DC</sub> Input
Load VSWR	< 2:1 Rated Power
Harmonic Levels	70 dB below Unmodulated Carrier
Modulation: Rate Type Format	4.8kbps, 9.6 kbps, and 19.2 kbps BPSK (4.8 kbps); GMSK (9.6kbps & 19.2kbps) NRZ
Spurious	> 70 dB below Unmodulated Carrier
Transmit Modulation Spectrum	10 kHz offset – 40 db 25 kHz offset – 70 db
Tx Duty Cycle	16% Max without shutting down transmitter 20% will shut down the transmitter
T/R Switch	Solid-State Switching Time < 100 microseconds
I/O	MCC Standard (Refer to Section 3.2)
High VSWR Protection	Withstands Infinite VSWR

**TABLE 2.3**

**MCC-6120 SDR HIGH BAND RECEIVER SPECIFICATIONS**

CHARACTERISTIC	SPECIFICATION
Frequency	151-160.6 MHz .0005% DDS 1 Hz steps
Modulation: Rate Type Format	4.8kbps, 9.6 kbps, and 19.2 kbps GFSK (4.8 kbps); GMSK (9.6kbps & 19.2kbps) NRZ ±5kHz deviation Voice ±2.5kHz deviation Voice
Noise Figure	< 9 dB minimum
Sensitivity: Bit Error Rate < 10 <sup>-3</sup> at 9.6 kbps	-112 dBm
IF Bandwidth (3/80 db)	13/40 kHz typical
RF Bandwidth (3 db)	13 MHz typical
Signal Acquisition Time	< 5 msec
3 <sup>rd</sup> Order Intercept Point	>- 4 dBm
Image Response Attenuation	> 70 dB minimum
Spurious Response Attenuation	> 70 dB minimum
I/O	MCC Standard (Refer to Section 3.2)

**TABLE 2.4****MCC-6120 SDR HIGH BAND TRANSMITTER SPECIFICATIONS**

CHARACTERISTIC	SPECIFICATION
Frequency	151-162 MHz .0005% Synthesized 10KHz steps
RF Power Output	> 30 Watts at 13.5 V <sub>DC</sub> Input
Load VSWR	< 2:1 Rated Power
Harmonic Levels	70 dB below Unmodulated Carrier
Modulation: Rate Type Format	4.8kbps, 9.6 kbps, and 19.2 kbps GFSK (4.8 kbps); GMSK (9.6kbps & 19.2kbps) NRZ ±5kHz deviation Voice ±2.5kHz deviation Voice
Spurious	> 70 db below Unmodulated Carrier
Transmit Modulation Spectrum	10 kHz offset – 40 db 25 kHz offset – 70 db
Tx Duty Cycle	16% Max without shutting down transmitter 20% will shut down the transmitter
T/R Switch	Solid-State Switching Time < 100 microseconds
I/O	MCC Standard (Refer to Section 3.2)
High VSWR Protection	Withstands Infinite VSWR

**TABLE 2.5**

MCC-6120 SDR MICROPROCESSOR SPECIFICATIONS

CHARACTERISTIC		SPECIFICATION
Main Processor		Motorola MC68332FC 32-bit Embedded Controller
Memory:	Program Storage Data Storage Parameter Storage Calibration Storage	2M x 16 non-volatile Flash memory (Flash1) 64M x 16 dynamic RAM 2M x 16 non-volatile Flash memory (Flash2) 8K EEPROM
Switches:	S1	System Reset, Momentary

TABLE 2.6

## 2.5 Memory Organization

The MCC-6120 SDR has four types of memory:

**Program Memory** The Program Memory is non-volatile Flash memory (2Meg x 16). This is also referred to as **Flash1** in the documentation. It contains the MBNET200 image software, the DSP image software, configuration, and application software. These programs are installed at the MCC facilities at the time of shipment. The information stored in the Program Memory is referred to as “factory defaults”.

**Parameter Memory** The Parameter Memory is non-volatile Flash memory (2Meg x 16). This is also referred to as **Flash2**. It contains the configuration data for the unit such as the customer number, the serial number and ID of the MCC-6120 SDR and the authorized FCC frequencies it may use. This information is normally programmed into the unit prior to shipment. The Script files are also stored in Parameter memory, either at the MCC facilities or on site.

**Calibration Memory** The Calibration Memory is serial Electrically Erasable memory (8,192 Kbyte EEPROM) used to store specific parameters associated with the calibration of the radio. These parameters are set when the radio is manufactured and/or when it is recalibrated by trained technicians in a laboratory. They cannot be changed in the field. These parameters include:

- freqcal                      Calibrates the 19.2 MHz TCXO
- lb\_rx-gain                    Calibrates the Low Band RSSI (detrf)
- hb\_rx-gain                    Calibrates the High Band RSSI (detrf)
- hb\_tx-gain                    Calibrates the High Band Tx gain

When the unit is rebooted by entering the **BOOT** command, or whenever the unit is power cycled, the ColdFire software will reload these

parameters into the DSP. They can also be reloaded by entering the following command **LOADCAL**.

Data Memory      The Data Memory is volatile 64 MByte RAM (16 Meg x 32). Date, time, executable programs, command parameters and program dynamic data (messages, data, position, etc) are all stored in RAM during normal operations.

During normal operation, the MCC-6120 SDR software uses the data and configuration parameters stored in RAM. If the data information in RAM is lost or corrupted, for whatever reason, the configuration parameters can be retrieved from Parameter and/or Calibration memory. This ensures uninterrupted operation.

The RAM contents will be lost under the following conditions:

- The Reboot command is issued.
- The Reset button (S1) is depressed (located inside the unit)
- The internal backup battery fails or is disconnected. (By unsoldering)
- The watchdog timer initiates a restart.
- The unit is powered off

The software will detect these events and will recopy the parameters and configuration values from Parameter memory back into RAM when operation is resumed.

If the contents of Parameter memory become invalid the unit will revert to the factory defaults in Program memory.

The Operator Port of the MCC-6120 SDR is programmed with the following default configuration at the time of shipment:

Baud rate	9600
Data bits	8
Stop bit	1
Parity	no
Protocol	ASCII
Flow control	no

This provides a known starting point when first connecting an operator terminal to the MCC-6120 SDR. This setting should not be changed.

## 3.0 INSTALLATION

Site selection and general installation guidelines are provided in this section, including instructions for cabling, antenna and power source connections. Power up procedures, initialization and preliminary functional test procedures are described that should be performed prior to placing the MCC-6120 SDR on-line within the network. The following types of installations are described:

- Base Stations and Repeaters
- Mobiles
- Fixed Data Collection Sites

### 3.1 Site Selection

The site selection criteria given in this section is generally applicable for base stations, repeaters and fixed data sites. General guidelines for mobiles are provided in Section 3.2.1. There are 4 important factors to consider in selecting an optimum site:

- External noise/interference
- DC power source
- Antenna height
- Antenna type

#### 3.1.1 External Noise/Interference

Noise and signal interference can reduce the performance of the MCC-6120 SDR. The most common sources of noise and interference are as follows:

- Power Line Noise
- Computer-Generated Interference
- External Signal Interference

#### **Power Line Noise**

One of the main sources of external noise are high voltage power lines. Noise on these lines is generated by high voltage breakdown occurring on power line hardware such as transformers and insulators. This noise can be seen on the MCC-6120 SDR using the **MM** command – enter **MM,100,DIST** to see the distribution of noise detected at the site. Typical power line noise will occur as a series of spikes every 8 ms (1/60 Hz) or every 10 ms (1/50 Hz). The level of the spikes will be much higher than the normal background noise floor (usually -120 dBm or less). The number of spikes can vary, depending upon the level of interference, from one or two every

8-10 ms to several dozen every 8-10 ms. As the number of spikes increase, the level of interference also increases. When setting up a site, always use the **MM** command to determine the level of the power line noise interference. It is mandatory that power line noise be avoided for an optimum site. Try to place the receiver antenna well away from power lines.

**NOTE**

Power companies are required to properly maintain their power lines to reduce noise. Call the local utility in case of severe noise.

### **Computer-Generated Interference**

All computers and printers contain high-speed circuits that generate spurious signals throughout the 39-50, 151-160 MHz band. Interference will result if any of these signals couple into the antenna at the MCC-6120 SDR receive frequency. To minimize this type of interference, try to keep the antenna away from computers by at least 100 feet.

### **Signal Interference**

This type of interference will occur whenever another transmitter is producing harmonics at the receiver center frequency of the MCC-6120 SDR. Antenna nulling and spatial separation can be used to reduce this type of interference.

**NOTE**

With XTERMW installed (see Section 3.3), the STAT command can be used to determine the site antenna noise levels. Ideally, the background noise levels should be less than  $-107$  dBm ( $1\mu\text{V}$  into  $50\Omega$ ).

### 3.1.2 DC Power Source

The MCC-6120 SDR requires a 12-15 V<sub>DC</sub> power source. The average standby current is about 600 mA. When the unit transmits (low band) it requires about 22 amps for 100 msec. For normal operation, including the transmitter, the average current requirement will be approximately 2.8A when operating at a normal duty cycle of 10%. An automobile battery provides an excellent power source.

When the unit is operating as a base station there will normally be AC power available. A car battery connected to a battery charger provides a good solution. In the event of a power outage the battery will keep the MCC-6120 SDR on-line and operational for several days until the power is restored.

**CAUTION**

**The MCC-6120 SDR does not have an internal fuse and consideration should be given to installing an external fuse.**



The power cable between the battery and the MCC-6120 SDR should be kept shorter than 10 feet and rated at #14 AWG or lower. (See Section 3.2.2.1 for more details.)

### 3.1.3 Antenna Selection

Vertical polarization is used in a network to provide omni-directional coverage to all adjacent nodes in the LOS network. A good choice for a base station antenna is dual stacked dipoles mounted on two sides of a triangular tower. A ½ wavelength whip is a good antenna choice for a data collection site.

For mobile applications, a ¼ wavelength dipole is a good choice when mounting to a roof or fender of a vehicle.

#### **IMPORTANT**

Refer to the **Important Safety Instructions for Installers and Users** at the front of this manual for **RF Exposure Information**. This section contains a list of precautions that must be observed in order to comply with Federal Communications Commission safety standards for human exposure to radio frequency (RF) energy.

The information bandwidth of the system is less than 25 kHz, therefore, a very narrow bandwidth antenna may be used. The antenna must provide a 50Ω load.

Always consult with MCC's engineering department for assistance when any questions arise with respect to antenna selection.

Assembly instructions are included with each antenna. Please refer to these for proper assembly for all antenna elements.

### 3.1.4 Antenna Height

In general, the higher the antenna is above ground the better the performance will be. The link gain will be increased by approximately 6 db every time the antenna height is doubled. A trade-off will be the antenna cable length because this must be kept as short as possible to minimize line losses. Line loss between the antenna and the MCC-6120 SDR should be less than 2 db.

A table of cable loss (at 50 MHz) for various types of co-ax cable is given below for reference.

CABLE TYPE	Loss/100 feet (db)	Diam. (Inches)	Weight/100 feet (lbs.)
RG 223, RG 58	3.0	.211	3.4
RG 214, RG 8	1.8	.425	12.6
RG 17	1.2	.870	20.1
LMR-240 ultra flex	2.0	.240	3.4
LMR-400 ultra flex	1.0	.405	9.0

LDF4A-50 1/2 inch heliax	.48	.500	15.0
LDF5A-50 7/8 inch heliax	.26	.875	33.0

A table of cable loss (at 160 MHz) for various types of co-ax cable is given below for reference.

CABLE TYPE	Loss/100 feet (db)	Diam. (Inches)	Weight/100 feet (lbs.)
RG 223, RG 58	5.1	.211	3.4
RG 214, RG 8	2.6	.425	12.6
RG 17	1.8	.870	20.1
LMR-240 ultra flex	3.7	.240	3.4
LMR-400 ultra flex	1.9	.405	9.0
LDF4A-50 1/2 inch heliax	.82	.500	15.0
LDF5A-50 7/8 inch heliax	.45	.875	33.0

A table of cable loss (at 1000 MHz) for various types of co-ax cable is given below for reference.

CABLE TYPE	Loss/100 feet (db)	Diam. (Inches)	Weight/100 feet (lbs.)
RG 223, RG 58	13.4	.211	3.4
RG 214, RG 8	7.3	.425	12.6
RG 17	5.3	.870	20.1
LMR-240 ultra flex	9.6	.240	3.4
LMR-400 ultra flex	4.9	.405	9.0
LDF4A-50 1/2 inch heliax	2.2	.500	15.0
LDF5A-50 7/8 inch heliax	1.3	.875	33.0

A table of cable loss (at 2.4 GHz) for various types of co-ax cable is given below for reference.

CABLE TYPE	Loss/100 feet (db)	Diam. (Inches)	Weight/100 feet (lbs.)
RG 223, RG 58	21.8	.211	3.4
RG 214, RG 8	12.3	.425	12.6
RG 17	9.3	.870	20.1
LMR-240 ultra flex	15.2	.240	3.4
LDR-400 ultra flex	7.9	.405	9.0
LDF4A-50 1/2 inch heliax	3.4	.500	15.0
LDF5A-50 7/8 inch heliax	1.9	.875	33.0

When operating at a fixed data collection site an antenna height of 20 feet above ground will normally be sufficient.

## 3.2 Equipment Installation

The MCC-6120 SDR operates over a temperature range from -30°C to +60°C and is normally housed in a stainless steel enclosure; however, it is not waterproof.

A NEMA waterproof enclosure is recommended for outdoor installations. To ensure proper operation, shielded cable is recommended for all connectors. Always use adequate strain relief on all cables and a weatherproof seal at the entry point of the enclosure.

If the unit is housed inside a restricted enclosure care must be taken to remove excess heat from inside the enclosure. The MCC-6120 SDR will consume 12-15 watts in a receive-only mode. While transmitting, the unit can consume up to 150 watts. Operating at a 10% duty cycle will, therefore, result in a power dissipation of about 30 watts.

### 3.2.1 Mobile Installations

Mobile applications can include vehicles, aircraft, vessels, and locomotives. A different type of antenna may be required for each application. For example, a 3' whip (at low band or high band VHF) is generally a good solution for vehicles. Low profile antennas, vertically polarized, are required for locomotives. 10' whips are generally used for vessels; these antennas should be designed for operation in maritime environments. Consult with the MCC sales department for specific antennas recommended.

For vehicle installations the MCC-6120 SDR may be mounted in any convenient location, e.g., in the trunk, under the seat, or in the engine compartment.

#### **IMPORTANT**

Refer to the **Important Safety Instructions for Installers and Users** at the front of this manual for **RF Exposure Information**. This section contains a list of precautions that must be observed in order to comply with Federal Communications Commission safety standards for human exposure to radio frequency (RF) energy.

### 3.2.2 Cable Connections

There are a maximum of eight (8) cable connections to be made to the MCC-6120 SDR as shown below. These connections are used for both mobile and fixed site applications.

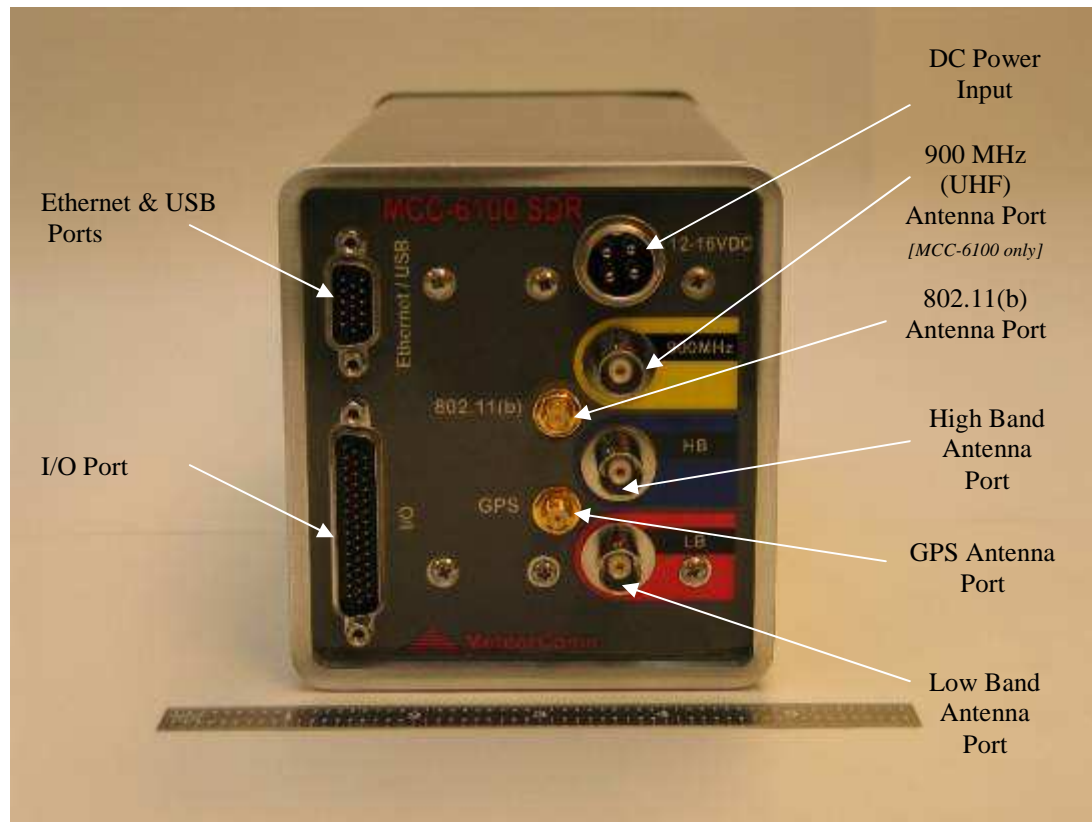

3.2.2.1 DC Power Input

The MCC-6120 SDR requires a power source that can deliver up to 25 amps of pulsed power (100 msec) out of a +12 V<sub>DC</sub> to +14V<sub>DC</sub> power source. The 25 amp power demand will cause a voltage drop to occur at the transmitter input, resulting in reduced transmit power, unless the power cable to the source is sized appropriately. MCC recommends using two #16 AWG wires for both the power and ground and a cable length that does not exceed 10 feet. If a longer cable is required use #14 AWG. MCC provides a standard 6 foot power cable with lugs for connecting to a 3/8” battery post (Part No. 14001350-01).

The power connector pins are as follows:

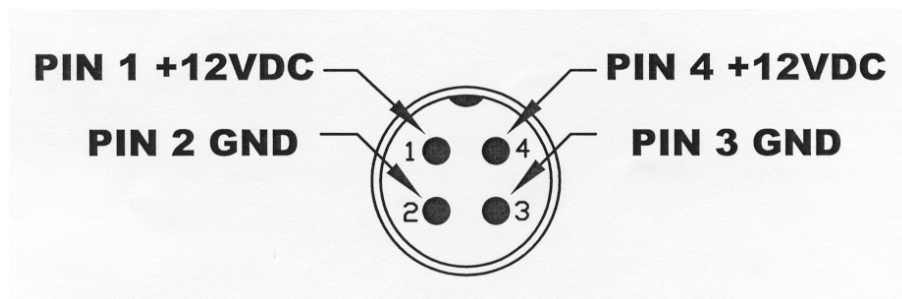

The voltage at pins 1 and 4 should not drop by more than 2V<sub>DC</sub> during transmission.

**3.2.2.2 LB/HB Connectors**

Connect the Low Band VHF and High Band VHF antenna cables to the two BNC RF connectors, being careful to observe the proper frequency bands. Use double-shielded coax for all connections. RG-223 (double-shielded) may be used for cable lengths under 30 feet for the low band and high band antenna. Use a double-shielded cable RG-214 for lengths up to 100 feet for the low and high bands. Refer to Section 3.1.4 for coax cable losses at the various frequency bands.

**3.2.2.3 GPS Antenna**

Connect an external GPS antenna to this SMA connector on the front panel when the internal GPS receiver is used. Note: GPS antennas have a built in amplifiers that require a DC voltage (3-5 V) on the center conductor.

**3.2.2.4 802.11(b)**

Connect an external 802.11(b) antenna to this reverse-SMA connector on the front panel. Use the Antenex TRA24003P 3dB omni directional antenna for the 802.11(b) antenna. Avoid excessive cable lengths that would induce >3 dB cable loss from the antenna to the radio. It is recommended that LMR 240 Ultra Flex be used for cable runs up to 20 feet. If longer runs are required, use the LMR 400 Ultra Flex cable.

**3.2.2.5 I/O Port**

The 44 pin I/O connector on the front panel includes three RS-232 ports and one Sensor port. MCC provides a standard cable harness that breaks out these four ports as shown below:

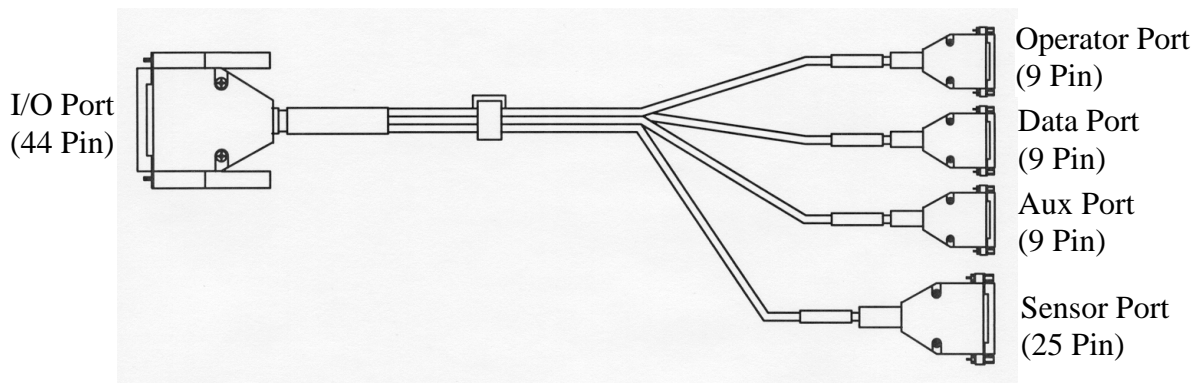

**MCC PART NO. 14001352-01**

3.2.2.5.1 Operator Port

The Operator Port is normally connected to a local operator terminal. Use a standard RS-232 cable with a 9-pin male D connector.

<b>OPERATOR PORT – 9S</b>	
<b>Pin</b>	<b>Signal</b>
1	CD
2	Tx Data
3	Rx Data
4	DTR
5	Ground
6	DSR
7	RTS
8	CTS
9	Not Used

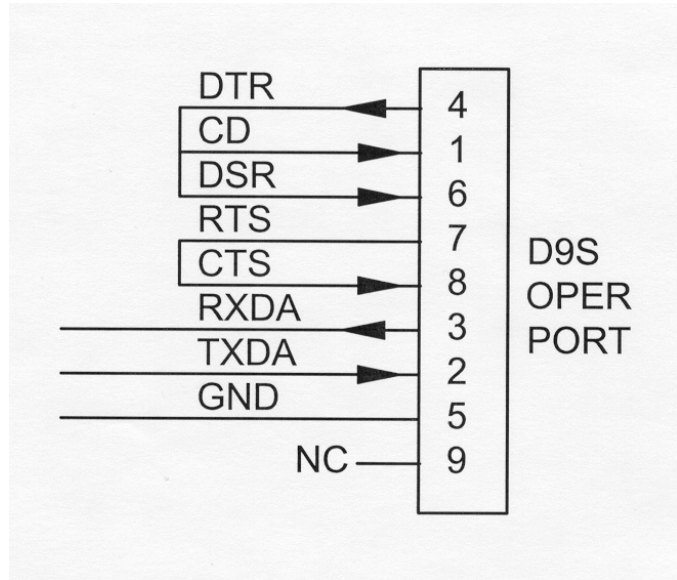

3.2.2.5.2 Data Port

The Data Port may be used for connecting to a data logger, GPS receiver or other serial input device. Use a standard RS-232 cable with a 9-pin male D connector.

<b>DATA PORT – 9S</b>	
<b>Pin</b>	<b>Signal</b>
1	Not Used
2	Tx Data
3	Rx Data
4	DTR
5	Ground
6	DSR
7	RTS
8	CTS
9	Ring

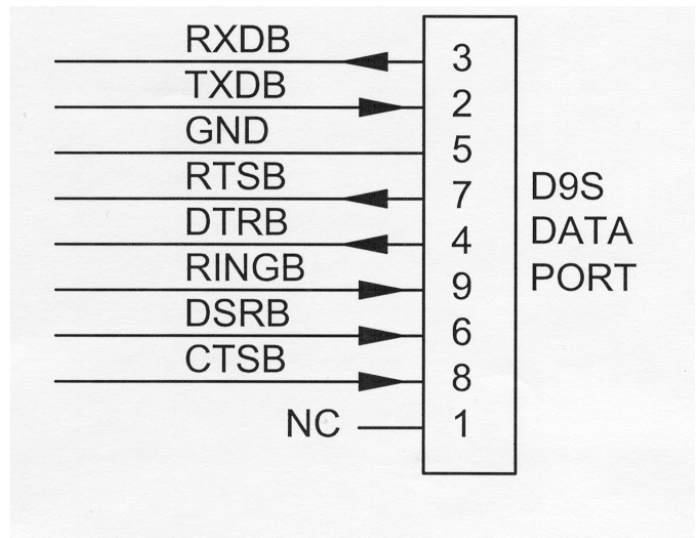

3.2.2.5.3 Auxiliary Port (AUX)

The AUX PORT may be connected to a GPS receiver or other serial input device. Use a standard RS-232 cable with a 9-pin male D connector. This port is also used for interfacing to MCC test equipment (pins 6, 8, and 9).

AUX PORT – 9S	
Pin	Signal
1	Not Used
2	Tx Data
3	Rx Data
4	Not Used
5	Ground
6	MCLK (TTL)
7	Not Used
8	MDIR (TTL)
9	MSET (TTL)

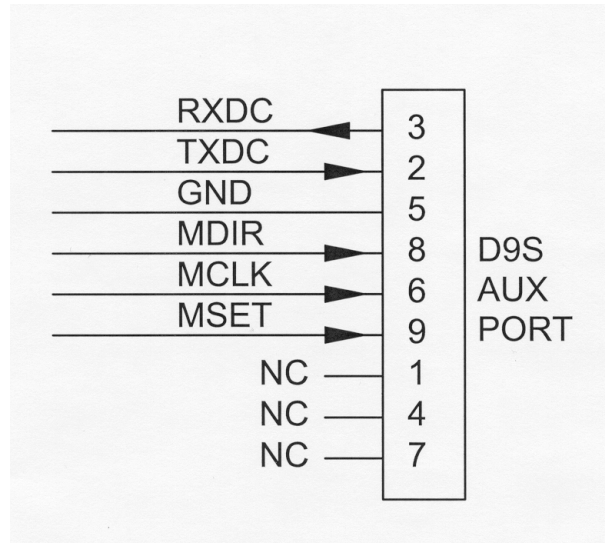

**IMPORTANT**

The AUX port connector has three extra pins (pins 6, 8, and 9) whose signals do not conform to the RS-232 standard. These are for MCC test purposes. These pins will NOT interfere with a normal 3-wire RS-232 connector (pins 2, 3, and 5).

3.2.2.5.4 Sensor Port

The Sensor port is used as a general purpose Supervisory Control and Data Acquisition (SCADA) interface requiring limited I/O in lieu of a full data logging capability. Use a mating cable with a 25-pin male D connector for access to the various functions. For convenience, this cable may be routed to a terminal block for interfacing to the various sensors and other external devices.

<b>SENSOR PORT</b>	
<b>Pin</b>	<b>Signal</b>
1	Optocoupled input #1 positive
2	(no connection)
3	Optocoupled input #2 positive
4	Optocoupled input return
5	Optocoupled input #3 positive
6	(no connection)
7	Optocoupled input #4 positive
8	(no connection)
9	Ground
10	MIC_HI
11	MIC_LO
12	Push-To-Talk
13	RX_AUDIO1
14	RX_AUDIO2
15	MUTE
16	Switched +12V (0.5A maximum)
17	Analog Input #1 ( 0 to 5 V) $\pm 0.5\%$
18	Analog Input #2 ( 0 to 5 V) $\pm 0.5\%$
19	Analog Input #3 ( 0 to 5 V) $\pm 0.5\%$
20	Analog Input #4 ( 0 to 5 V) $\pm 0.5\%$
21	Analog Input #5 ( 0 to 5 V) $\pm 0.5\%$
22	Analog Input #6 ( 0 to 5 V) $\pm 0.5\%$
23	+5V Reference (10mA for sensor excitation)
24	+12V (0.5A maximum)
25	Detected RF Test Point

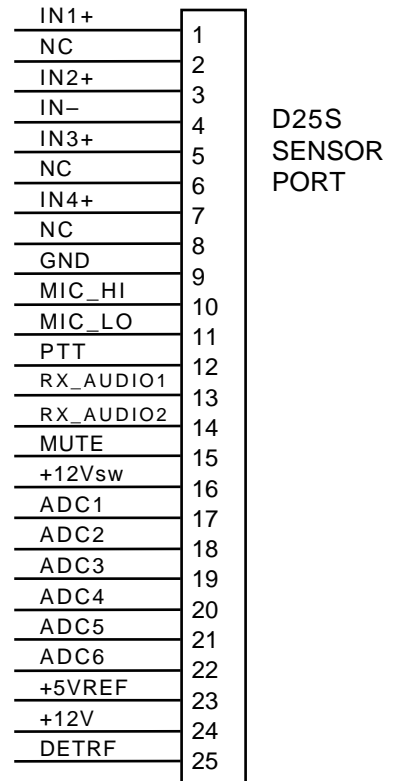



3.2.2.6 Ethernet/USB Connector

The SDR has two Ethernet Network two independent Interface Adaptors and two USB adaptors. Connections to these adaptors are made thru a 15 pin sub miniature D connector located on the front panel. An interface cable (provided by MCC) is used to break these connections into standard RJ 45 plugs for the Ethernet signals and a standard USB Host connector for the USB Host, and a standard USB Device connector for the second USB port. The Host port is used to plug memory sticks and camera devices into. The second USB port allows the SDR to operate as a USB Host, so it can be used to connect a laptop into for purposes of programming the radio.

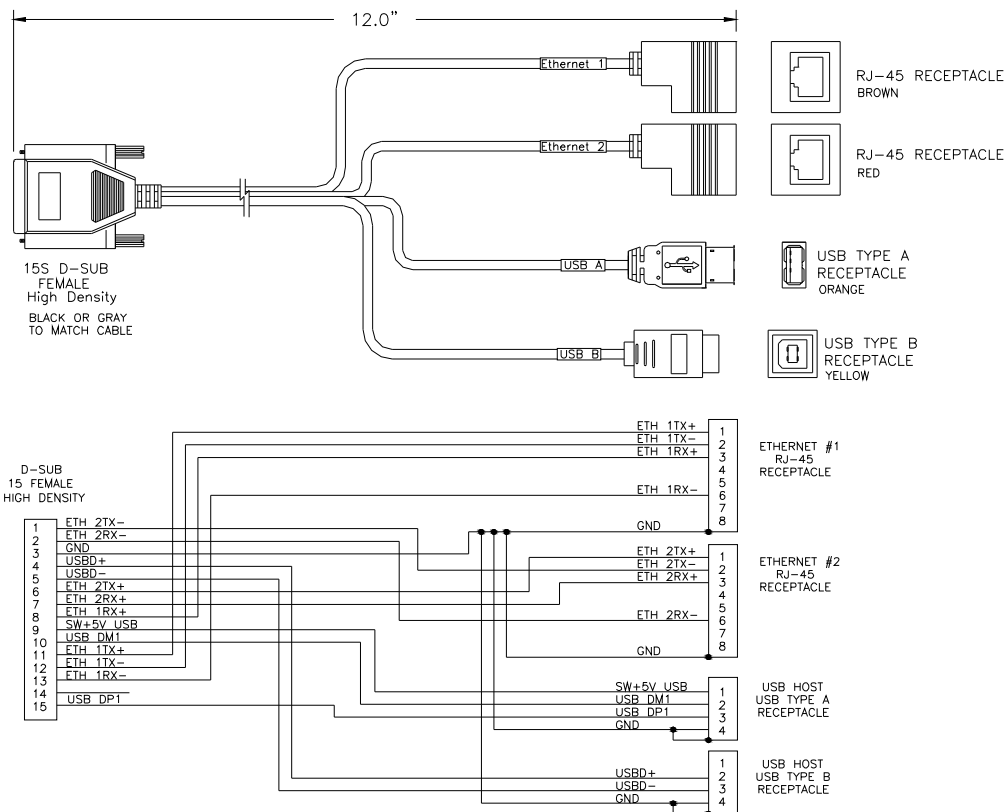

Ethernet-USB Connectors

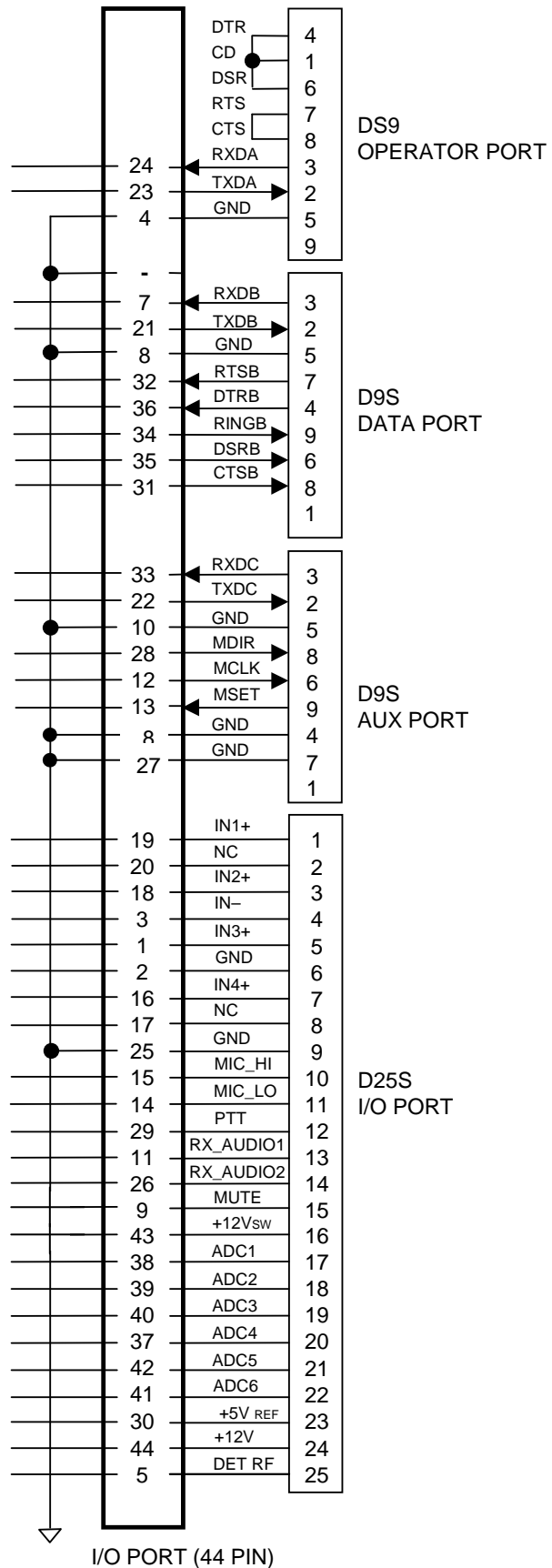

### 3.3 Power-Up Sequence

#### IMPORTANT

Before applying power to the MCC-6120 SDR, check all connections between the MCC-6120 SDR and the external equipment (power, antenna, operator terminal, and data logger). Refer to Section 3.2.3 for cabling instructions.

#### 3.3.1 Connect Operator Terminal

Connect a laptop or an operator terminal, with XTERMW installed and running, to the Operator Port. XTERMW is an MCC windows-based terminal emulation program designed for interfacing with MCC products. The operator terminal must be programmed with the same configuration parameters as the Operator Port.

The Operator Port of the MCC-6120 SDR is programmed with the following factory default configuration at the time of shipment:

Baud rate	9600	Parity	none
Data bits	8	Protocol	ASCII
Stop bit	1	Flow control	none

#### 3.3.2 Power Connection

Power up the MCC-6120 SDR by applying +12VDC to the power connector.

#### NOTE

When the unit transmits, it will draw up to 20 amps; therefore, review section 3.2.3.1 for proper cabling to the power source. The voltage drop at the input connector during transmission should be less than 2 V<sub>DC</sub> for proper operation of the unit. Verify this during the Operational Test Procedure in Section 3.4.

When power is initially applied to the MCC-6120 SDR, or after a software boot or hardware reset, the following message will be displayed:

```

MCC-6120 SDR PACKET DATA RADIO
(c) Copyright 2005 Meteor Communications Corp.
    All Rights Reserved
S/W Part Number P1101-00-00 MCC-6120 Version 1.14 11/05/05
S/W Part Number P1102-00-00 DSP SDR Version 1.10 07/14/04
S/W Part Number P1103-00-00 DSP FPGA Version 4 07/14/04
S/W Part Number P1121-00-00 Flexbus FPGA Version 7 11/03/05

```

\* Part Number, Version Number, and date vary according to a particular radio's Firmware.

At this time all configuration data is loaded from Program Memory into RAM. This data will remain in RAM until power cycled.

This is the type of message that should be displayed when you first apply power to the unit during a field installation, and for each subsequent power cycle of the radio.

After power is applied to the radio all parameters that were entered and saved during the previous session will be reloaded from Flash2 memory.

If you want to load factory defaults, power cycle the unit while holding the lower case **f** key down. After about 10-15 **f**'s are displayed, release the key and you should see the following message:

```
+ffffffffffffffffffffffffffffffff
Ver 1.0
SDR Boot... (Entry due to operator request)
1.. Factory Default
9.. Launch Application
```

Enter a 1 followed by carriage return to restart with factory default parameters.

Enter a 9 to restart the application without changing the stored parameters.

If you restart with factory defaults, the proper script file must be re-entered into the MCC-6120 SDR using XTERMW. (Refer to Section 3.3.3.5 for more information on using script files.)

If you do not have a script file to load you can go through the following procedure to manually start the unit.

### 3.3.3 Initialization Procedures

The following initialization procedures should now be performed in the order they are given below.

#### 3.3.3.1 Verify Device Type

The MCC-6120 SDR must be programmed to operate as a particular device type, such as Remote Station, Repeater, or Base, depending on your network configuration. The device type is normally set at the factory prior to shipment to ensure proper integration with your network.

Use the following command to display what device type the unit is configured as:

```
DEVICE [ENTER]
```

Always check with your System Administrator to determine which device type your unit should be configured as.

For example, if the device should be a Remote Station and it is not currently configured properly, you can change the device type, as follows:

```
DEVICE,REMOTE [ENTER]
SAVE [ENTER]
```

**CAUTION**

**Do not change the device type unless told to do so by your System Administrator. Changing the device type can make your unit cease operating and can impact communications throughout the entire network.**

### 3.3.3.2 Verify ID Number

Every MCC unit is programmed at the factory with a 16-bit unit ID. To display the unit ID number on the operator terminal, enter:

```
ID [ENTER]
```

Contact your System Administrator to make sure this ID is registered in the network configuration database. Under some circumstances the ID may have to be changed on-site. This can only be done if the ID is not locked.

**CAUTION**

**ID changes must be coordinated with both MCC and your System Administrator. Failure to do so may result in data or messages being misrouted or lost.**

**If the site is equipped with a CIM (Configuration Information Module), the ID for the MCC-6120 will be set from the CIM.**

### 3.3.3.3 Verify Channel Frequency

The MCC-6120 SDR is programmed at the factory with the authorized frequencies to be used on a specific channel in your network. These channels and frequencies are stored in Parameter memory and cannot be changed. Verify that the correct channel and frequency is configured by entering the command:

```
CHANNEL [ENTER]
```

or **CHAN** [ENTER] for short cut

This shows you the active or “primary” channel number and TX and RX frequency pair, plus up to 20 additional frequency pairs for channels that may be programmed at the factory.

For example, the following table could be displayed:

```

+chan 11/14/05 15:11:26
Primary Channel    TX mhz    RX mhz    Mod-Val
                01        44.5800   44.5800   1
11/14/05 15:11:26 Channel Table:
Channel           TX mhz    RX mhz    Mod-Val
>01*              44.5800   44.5800   1

```

**CAUTION**

**Do not change the frequency pair unless told to do so by your System Administrator. Changing the frequency pair can make your unit stop communicating with the network.**

3.3.3.4 Select Site Name

A descriptive name may be given to the site where the MCC-6120 SDR is being installed. The selected site name must be coordinated with your System Administrator. To enter a site name use the following command:

**SITE NAME**, nnnnnn [ENTER]

where: nnnnnn = maximum of 32 alpha-characters

**CAUTION**

**Please double-check the site name entry for correct spelling and spacing. Data from a site with an incorrect site name will be mishandled or misrouted by the Host. An incorrect site name can result in significant effort to recover misrouted data.**

3.3.3.5 Enter Script Files

The appropriate Script File is usually programmed into the MCC-6120 SDR at the factory prior to shipment. If the appropriate Script File has already not been entered, a new file can be loaded from your operator terminal using XTERMW software. There is one Script File that uniquely programs the MCC-6120 SDR to operate as a Remote Station in your specific or MeteorComm network.

**NOTE**

If the site is equipped with a CIM (Configuration Information Module), the MCC-6120 will automatically be scripted from the CIM.

The procedure for loading the Script File is described below:

1. Install the MCC-6120 SDR MeteorComm CD (or diskette), with the Script File on it into your operator terminal, and load the Script File into your XTERMW\XTS subdirectory.
2. Start XTERMW and open a connection at the correct baud rate and COM port (typically COM1, 9600 baud). All other parameters are defaults.
3. From the **Scripts** drop-down menu in XTERM, choose **Execute Script**.
4. Select the appropriate Script File in the XTERM subdirectory. Double-click the file name to start execution.

The commands in the Script File are executed one at a time until the end of the file is reached. Press the “up arrow” key to scroll up and review the command responses. If any commands result in BAD COMMAND, BAD PARAMETER, or a similar message, the Script File may have an error in it. If so, the script file needs to be corrected. Contact MCC or your System Administrator for a replacement.

You may verify that the correct configuration file has been loaded by entering the three commands: **ASSIGN**, **SNP**, and **CONFIG**.

**THIS COMPLETES THE INITIALIZATION PROCEDURE**

## 3.4 Operational Test Procedure

### 3.4.1 RF Test

A very thorough RF test can be made by entering the command **TEST** [ENTER]. **TEST** causes the processor to turn the transmitter ON and measures the forward and reverse RF power that is being transmitted. It also measures the battery voltage under load and the antenna noise voltage. The following response will be displayed on the operator terminal:

```

syncs   xmits   acks   pwr-fwd  pwr-rev  v-bat   det-rf  resets
xxxx      yyyy      zzzz      aaaa      bbbb      ccc       ddd       eee

```

where:

xxxx	=	# of sync patterns received from the master station.
yyyy	=	# of transmissions made by the MCC-6120 SDR.
zzzz	=	# of acknowledgements received from the Master Station.
aaaa	=	Forward power in watts. This should be greater than 80 watts.
bbbb	=	Reflected power in watts. This should be less than 5 watts.
ccc	=	Battery voltage under load (while transmitting). This should be greater than 10.6 V <sub>DC</sub> .
ddd	=	Received signal strength in dBm. This will normally be the noise level at the antenna and should read about -120.
eee	=	Number of times the radio has rebooted.

#### NOTE

The forward RF power should be at least 80 watts when operating at Low Band VHF, and 25 watts when operating in High Band VHF if the battery voltage is normal. If it is lower than these values check for proper cabling to the power source (see Section 3.2.2.1.).

If the reverse RF power is greater than 5 watts on any channel check the antenna and coaxial cabling for proper installation.

If both the forward and reverse power are low, the transmitter may be automatically shutting down due to an antenna VSWR greater than 3:1. Check the antenna and coaxial cabling for proper installation.

The DET RF value indicates the level of the RF signal plus noise at the antenna in dBm (dB above or below 1 milliwatt of power). Use the mm,50,dist command to obtain just the noise value. This noise level should be less than -90 dBm. The lower the number the lower the noise and the larger the operating range of the unit will be. Refer to Section 3.1 for reducing site noise conditions.

An overall figure of merit for the link performance is the XMIT to ACK ratio. If this ratio is 3:1 or lower, the overall performance will be very good.

**This completes the initialization and power-up sequence of the MCC-6120 SDR.  
The unit is now ready for operation.**