

RC-K3E

Three-Dimensional Touch Probes Instruction Manual

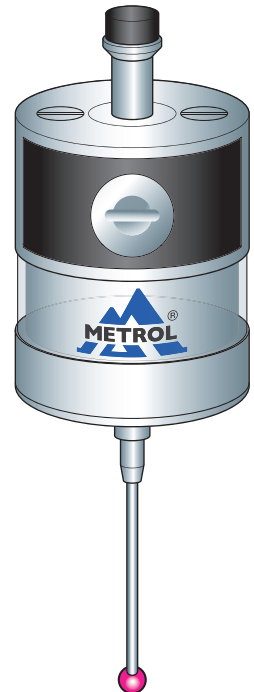

■FCC Regulation Notice

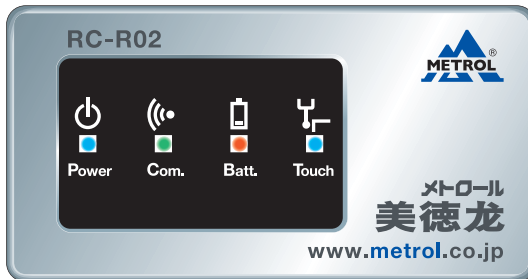

Metrol Co., Ltd.
Model : RC-K3E  
Power : 3.6V

CMIIT ID : YYYYxBzzzz

Made in Japan

FCC ID : AORMETROLRCK3E002

This device complies with Part 15 of the FCC Rules.
Operation is subject to the following two conditions:
1-this device may not cause harmful interference, and
2-this device must accept any interference received,
including interference that may cause undesired operation.

Metrol Co., Ltd.
Model : RC-R02  
Power : DC24V

CMIIT ID : YYYYxBzzzz

Made in Malaysia

FCC ID : AORMETROLRCR02

This device complies with
Part 15 of the FCC Rules.
Operation is subject to the
following two conditions:
1-this device may not cause
harmful interference, and
2-this device must accept
any interference received,
including interference that
may cause undesired
operation.

The changes or modifications not expressly approved
by the party responsible for compliance could void
the user' s authority to operate the equipment.
To comply with the FCC RF exposure compliance
requirements, this device and its antenna must not
be co-located or operating to conjunction with any
other antenna or transmitter.

INDEX

1.Before Using

Terms of Warranty	P1~2
Usage Precautions	P3

2.Basic Information

Dimensions	RC-K3E	P5
	RC-R02	P6
Specifications	RC-K3E	P7
	RC-R02	P8

3.Wireless Touch Probe

Transmission Range when Combining Probe and Receiver	P10
Preparations for RC-K3E		
1) Finger Attachment	P11
2) Installing and Replacing the Battery	P12
3) Attachment of Probe to Shank	P13
4) Finger Centering Adjustment	P14
Receiver Attachment	P15~16
Matching Probe and Receiver	P17
Operating Modes	P18

4.Maintenance

Cleaning the Probe	P19
Battery Replacement	P19

5.Troubleshooting

.....	P21~22
-------	--------

6.Parts List

.....	P23
-------	-----

1. Before Using

■ Terms of Warranty

We endeavour to achieve zero claims and complaints rate with respect to product quality assurance. Although malfunctions are a problem that comes before the warranty and even one should be prevented, malfunctions cannot be prevented through our efforts alone. We would therefore like to request that our customers have an understanding of the functions and specifications of applicable products as indicated in our catalogs, instruction manuals and web site to ensure that they are used properly under specified conditions.

Furthermore, applicable products are designed and manufactured primarily for general industrial use.

Therefore, we would also like to request our customers to cooperate in employing a safe design for preventing accidents, fires and the like through providing of fail-safe measures, preventing operational errors and employing redundant safety designs.

1) Applicable Products

The warranty defined below is applicable to products manufactured and sold by METROL (to be referred to as the "applicable products").

2) Warranty Period

The warranty for applicable products is valid for one year and three months from the original delivery date to the location designated by the customer.

**The initial three months are assumed to be a preparation period until use of the products following purchase.*

3) Range of Coverage

a. A replacement product will be provided on an exchange basis or the malfunctioned product will be repaired free of charge within the warranty period. If the product is or becomes defective and that at the sole discretion of METROL, the defect is due to faulty materials or workmanship.

However, applicable products will not be covered by the warranty in the case of the following malfunctions even within the warranty period.

- (I) Malfunctions occurred due to use of a product in a manner that deviates from standards, specifications, environments, usage procedures or usage precautions described in the catalog, instruction manual or specifications.
- (II) Malfunctions having occurred for reasons other than those attributable to the delivered product.
- (III) Malfunctions having occurred due to modifications or repairs made by someone else other than the Metrol representative.
- (IV) Malfunctions or damage that results from external causes outside our control which shall include accident fire disaster, other nature disaster or other force majeure.

-
- b. The range of coverage is limited to warranty of the applicable product only, and any other secondary loss or damage resulting from the malfunction of an applicable product is not covered by the warranty.
 - c. Please be aware that charges for service (including installation, de-installation on-site confirmation and repairs) are not included in the price of products.

4) Applications

Applicable products are designed and manufactured as general-purpose products used in ordinary industrial environments.

In the case of incorporating an applicable product in an apparatus, machine or system, please confirm the suitability of the application along with any related standards, regulations and restrictions.

With respect to the applications indicated below in particular, customers are requested to conduct necessary tests on an actual product in advance after consulting with the manufacturer regarding usage conditions and other details.

- a. Applications for which usage conditions or environment are outside those presumed by the manufacturer or applications unable to be confirmed as being appropriate by the manufacturer when using applicable products.
- b. Applications likely to have an effect on human life or property (such as nuclear power equipment, transportation machinery or medical devices), applications used in public utilities (such as electricity, gas or water lines), or applications applying correspondingly thereto.
- c. Applications in harsh environments (special environments requiring heat resistance, vacuum and the like)

**Although METROL believes that sound reliability in harsh environments is one of the characteristics of our products, there are still cases in which it is difficult to ascertain actual circumstances.*

Since there is the potential for accidents in such cases, customers are requested to have an understanding of protective structures, materials and so forth and provide additional covers and other equipment as necessary.

5) Other Matters

The contents of this catalogue, including specific models and, specifications, and any other contents, are subject to change without notice at METROL's sole discretion.

Although the utmost care has been taken in producing this manual, the manufacturer is not responsible for any damages incurred as a result of clerical or other errors in this manual.

1. Before Using

■ Usage Precautions

1) Battery

The RC-3KE comes with two 1 / 2AA size lithium metal batteries (non-rechargeable). Please dispose of used batteries in accordance with laws and regulations relating to the environment and safety regulations in your area. Do not attempt to recharge these batteries.

When replacing the battery, confirm that the battery is of the recommended or applicable type, and confirm that the battery is inserted while correctly aligning the electrodes in accordance with the procedure described in this manual and the indications on the product.

Please refer to the instruction manual of the battery manufacturer for guidelines relating to specific battery applications, safety and disposal.

- Please confirm that all batteries are inserted with the electrodes correctly aligned.
- Do not store batteries in locations subject to direct sunlight or rain.
- Do not allow the battery to be heated or incinerated.
- Do not intentionally discharge the battery.
- Do not allow the battery to be short-circuited.
- Do not disassemble the battery, subject the battery to excessive pressure, drill holes in the battery or allow it to be deformed.
- Take precautions so that the battery is not accidentally swallowed. Store the battery in a location out of the reach of children.
- Do not allow the battery to become wet.

2) Glass Window

The RC-R02 has a glass window. In the case the glass window should happen to be broken, handle the product carefully to prevent injury.

3) Installation Work

Please confirm that the following guidelines are strictly observed at the responsibility of the person performing installation work to ensure that the product functions properly.

- Please install while placing the interface at an adequate distance from electrical noise generation sources such as transformers or servo amplifiers.
- Connect all 0V / ground connections to a central ground terminal on the machine. (The grounding and shielded cables of all devices can be connected to ground.) This is extremely important, and failure to do so can cause the generation of an electrical potential between the product and ground.
- Connect all shields as indicated in the user's guide.
- Place cables at an adequate distance from large-current cables such as motor and other power cables as well as high-speed data cables.
- Try to keep cable lengths as short as possible at all times.

4) Product Usage

Use of this product in a manner other than that specified by the manufacturer may cause a decrease in the guaranteed performance and functions of the product.

NOTE

2.Basic Information

■Dimensions

RC-K3E

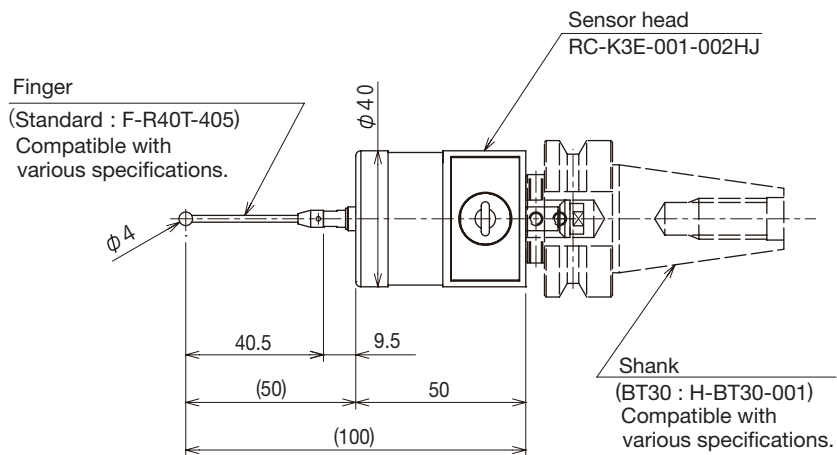

Finger Overtravel		
Finger length	$\pm X/\pm Y$	Z
50	7	3

■ Dimensions

RC-R02

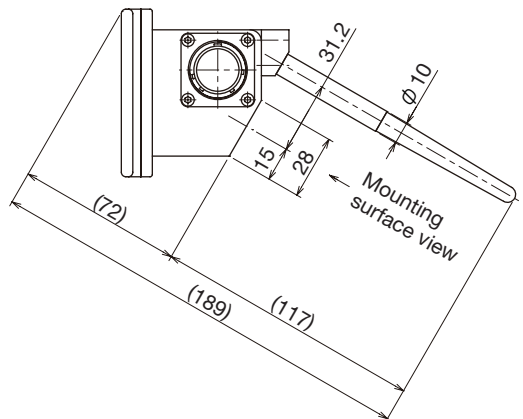
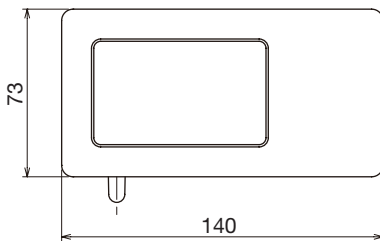
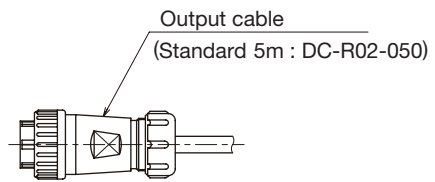
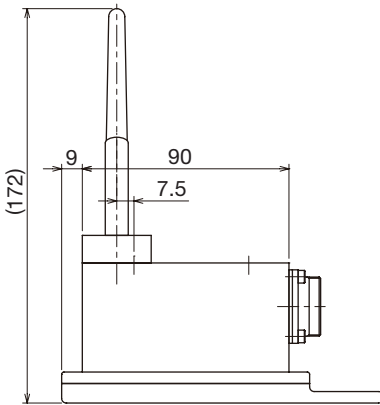
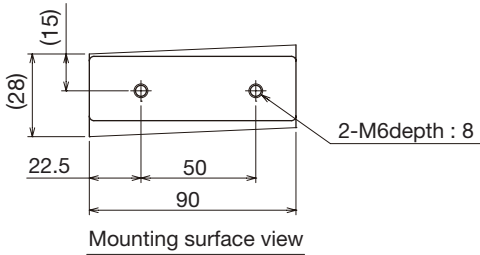

2.Basic Information

RC-K3E Specifications

Main applications	Workpiece dimension and centering measurements in CNC machine tools	
Weight (excluding shank)	With battery : 290 g Without battery : 280 g	
Signal transmission format	GFSK (DSSS) wireless transmission format	
No. of channels	37	
Wireless frequency	2400 MHz - 2480 MHz	
Power ON signal	M code (wireless signal)	
Power OFF signal	M code (wireless signal)	
Signal transmission range	Max. 15 m	
Receiver / interface	Receiver antenna-integrated interface	
Detected directions	5 directions $\pm X$, $\pm Y$, $\pm Z$	
Single direction repeatability	1.0 μm (transmission speed : 150 mm/min) Max : 2 sigma value (in all directions)	
Standard finger measuring pressure (when using 50 mm straight stylus)	XY : 0.5 N Z : 4.5 N	
Overtravel	XY directions : $\pm 7^\circ$ Z direction : 3 mm	
Usage environment (in accordance with standard BS EN 61010-1 : 2001)	Waterproof design	IEC IP67
	Storage temperature	-10°C - 70°C
	Operating temperature	5°C - 50°C
	For indoor use only	
Battery	1 / 2AA lithium-thionyl chloride battery (3.6 V) - 1	
Time until battery replacement	After start of low battery indication : approx. 1 hr	
Low battery indication	Flashing of battery alarm LED (red)	
Dead battery indication	Illumination of battery alarm LED (red)	
Battery life (reference value)	Refer to table below	

Battery	During standby	5% use (72 min / day)	Continuous use
1/2AA lithium-thionyl chloride battery	160 days	125 days	440 hours

■ RC-R02 Specifications

1) Wiring Diagram

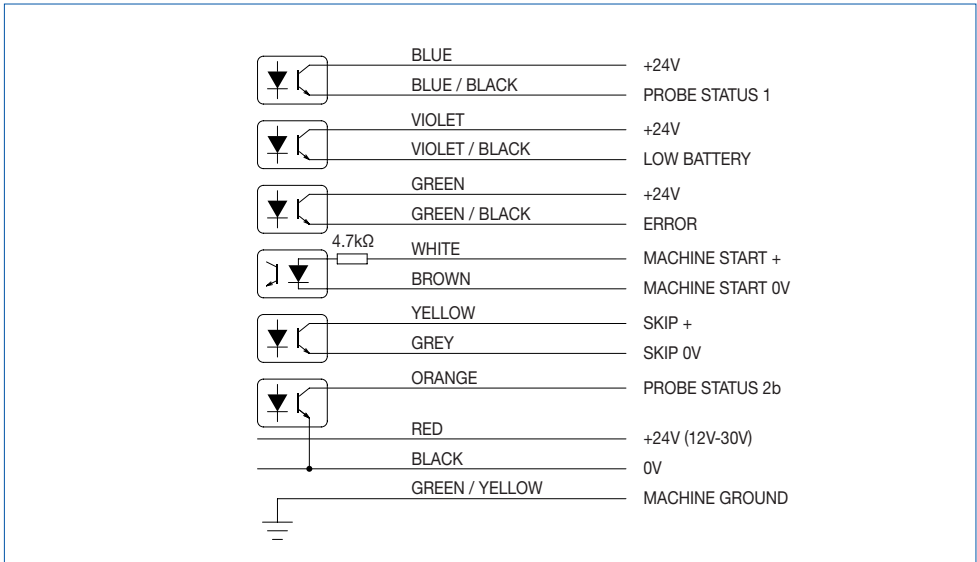

2) LED Display

System status is displayed with four LED shown at right.

- **Touch LED** : Indicates the signal output of the touch probe.
 - OFF : Signal not being received (touch probe signal output OFF)
 - : Signal received (touch probe signal output ON)

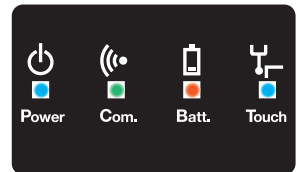

- **Batt. LED** : Indicates battery status of touch probe.
 - OFF : Battery normal
 - ● ● : Battery must be replaced (low residual charge)
 - : Battery dead
- **Com. LED** : Indicates communication status between touch probe and receiver.
 - ● ● : Communication status decreased or interrupted, or searching for connection
 - : Normal communication status
- **Power LED** : Indicates status of power supply.
 - ● ● : Receiver initiating immediately after machine tool power switched on
 - : Normal power supply status

NOTE

A series of horizontal dashed lines for writing notes.

■ Transmission Range when Combining Probe and Receiver

Probe and Receiver Installation Locations

Install the probe system at a location that enables the system to cover the communication range over the entire stroke of the movement axis of the machine. Use the communication LED display of the receiver as a reference for determining the optimum installation position.

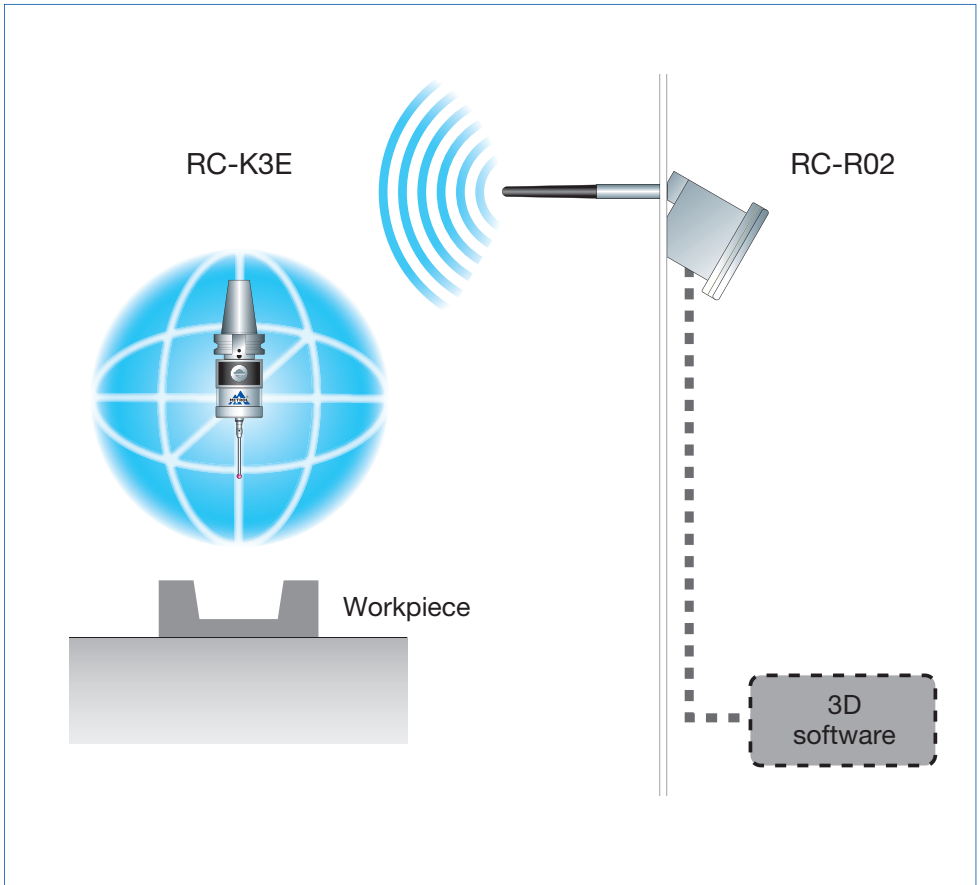

3. Wireless Touch Probe

■ Preparations for RC-K3E

1) Finger Attachment

① Insert the finger.

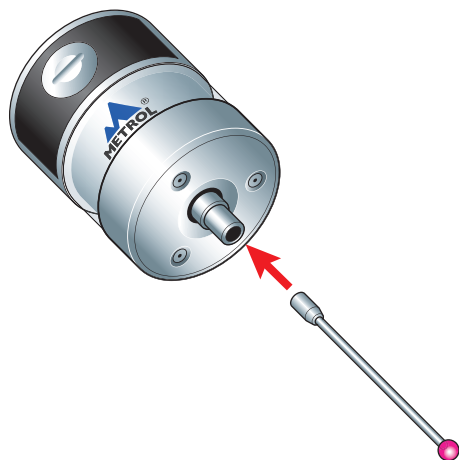

② Tighten using the hexagonal wrench and spanner.

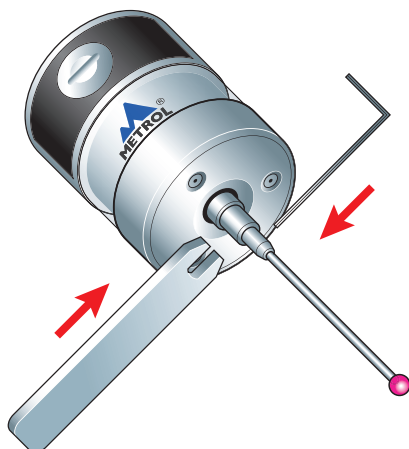

Hexagonal wrench
0.89 mm



Spanner S907

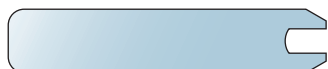

2) Installing and Replacing the Battery

Confirm the alignment of the battery electrodes when inserting the battery. The LED display will not light if a dead battery is mistakenly inserted into the probe (refer to P18). Do not allow coolant or cuttings to get inside the battery housing.

After attaching the battery cover, the LED will light for about 10 seconds. Do not touch the finger while the LED is lit. (The probe will switch to the matching mode if the finger is touched while the LED is lit. Reinstall the battery if this happens.)

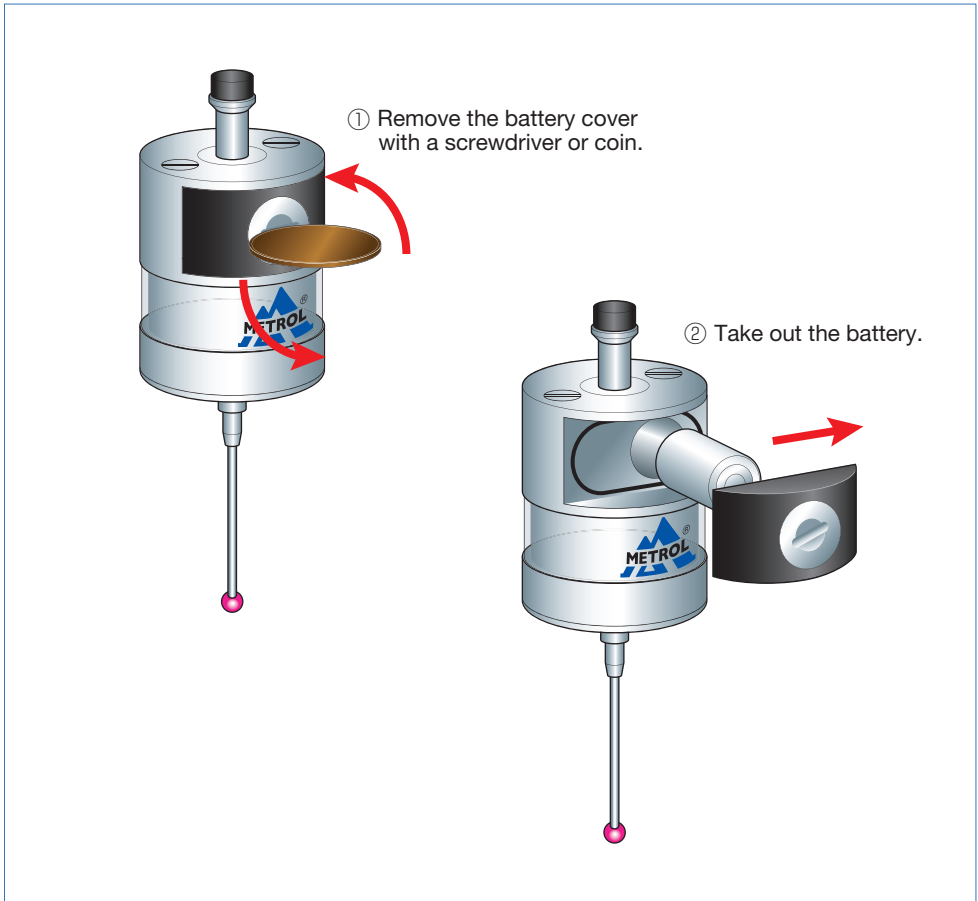

3. Wireless Touch Probe

■ Preparations for RC-K3E

3) Attachment of Probe to Shank

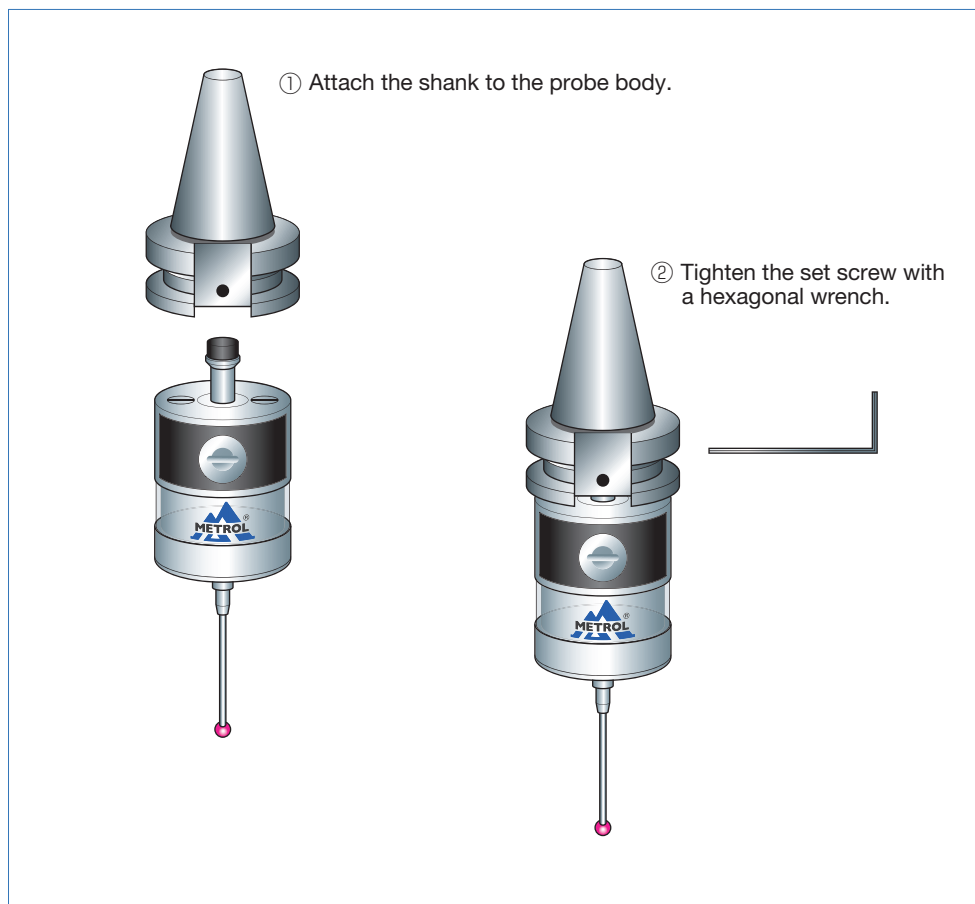

4) Finger Centering Adjustment

Caution: It is necessary to recheck the centering adjustment if the touch probe has been dropped. Absolutely never strike the probe when adjusting centering.

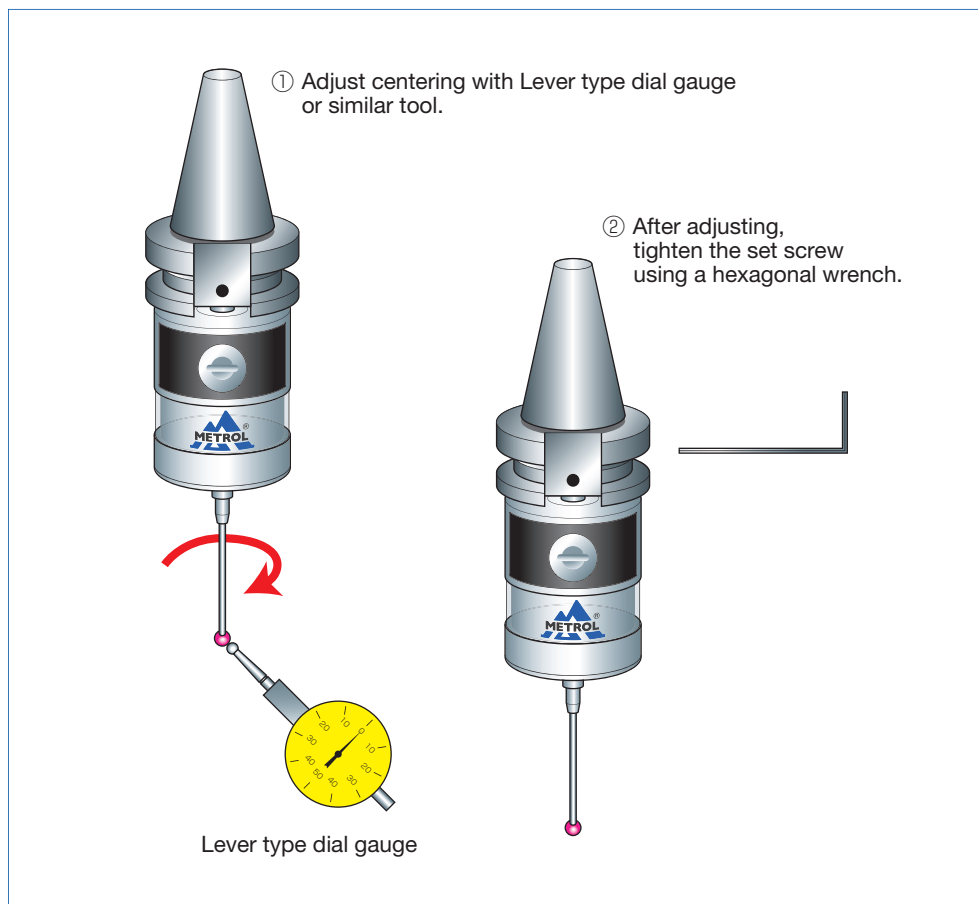

3. Wireless Touch Probe

Receiver Attachment

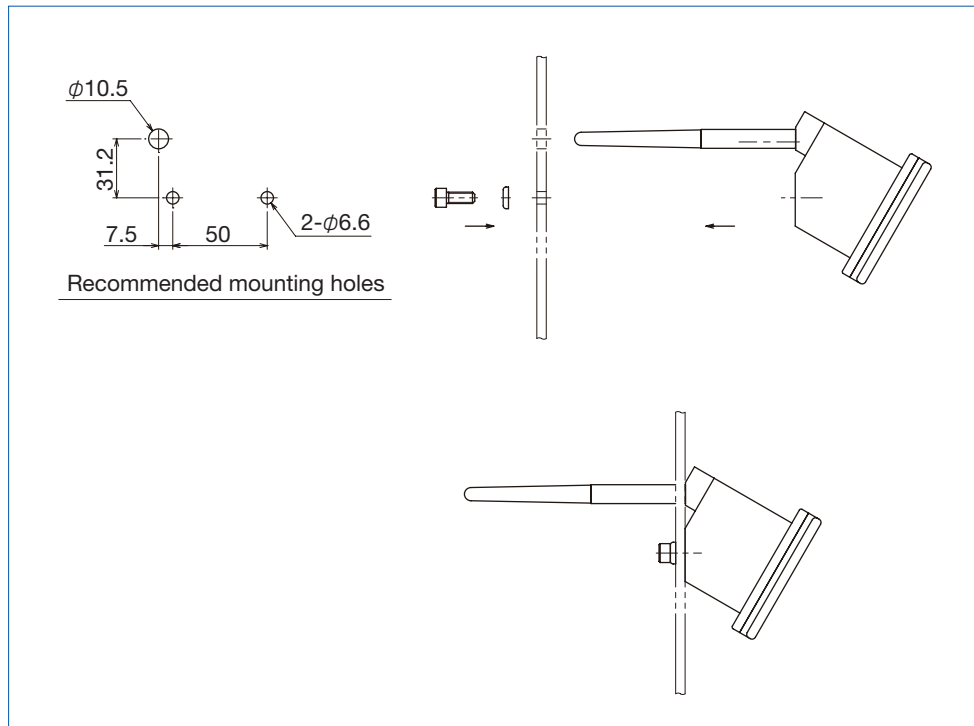

Attachment of Direct Cable

- Since the connector provides a waterproofing function when connected, insert the connector securely and tighten the clamp nut.
- Install the cable at an adequate distance away from electromagnetic noise generation sources.
- Always make sure to connect the cable to ground when connecting.

NOTE

A series of horizontal dashed lines for writing notes.

3. Wireless Touch Probe

■ Matching Probe and Receiver

It is necessary to match the probe and receiver when first installing the system. Matching is also required only when replacing either the touch probe or the receiver. Matching is not disabled when the power is turned off or when the battery is replaced. Matching can be performed anywhere within the range of movement of the system.

Detailed Diagram of DG SW

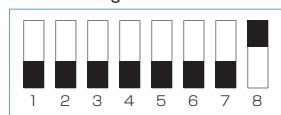

- The Com. LED flashes during matching.
- The Batt. LED lights when matching is completed.
- The Batt. LED is turned off by switching off the digital switch #8 on the receiver.

① Receiver Matching Procedure

- 1) Remove the cover of the receiver.
- 2) Switch on the digital switch #8 of the receiver.



Signal LED Display

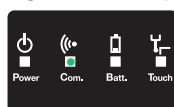

- Batt. LED LED Off
- Com. LED ● ● ● LED Flashing

② Probe Matching Procedure



< 5s



- 1) Switch ON the finger (state when contacting a processed object) within 5 seconds after turning on the sensor power (by temporarily removing the battery cover and then replacing).
- 2) The sensor is switched to the matching mode by switching the finger OFF within 2 seconds after switching it ON. (touch probe LED flashes.)

Signal LED Display

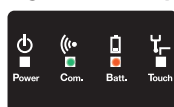

- Batt. LED ■ LED On
- Com. LED ● ● ● LED Flashing

Matching is completed when the Batt. LED lights.

< 2s



Return

③ Matching Mode Completion Procedure



- 1) The matching mode is terminated by switching the sensor finger ON (the sensor LED goes out).
- 2) Switch the digital switch #8 on the receiver to OFF.
- 3) Complete the matching procedure by attaching the receiver cover.

Note : The matching procedure is performed to record the sensor ID number in the receiver and prevent interference by other radio signals. Once the matching procedure has been performed, the sensor ID number is recovered in the receiver and further matching is not required provided the sensor is not replaced (or repaired).

■ Operating Modes

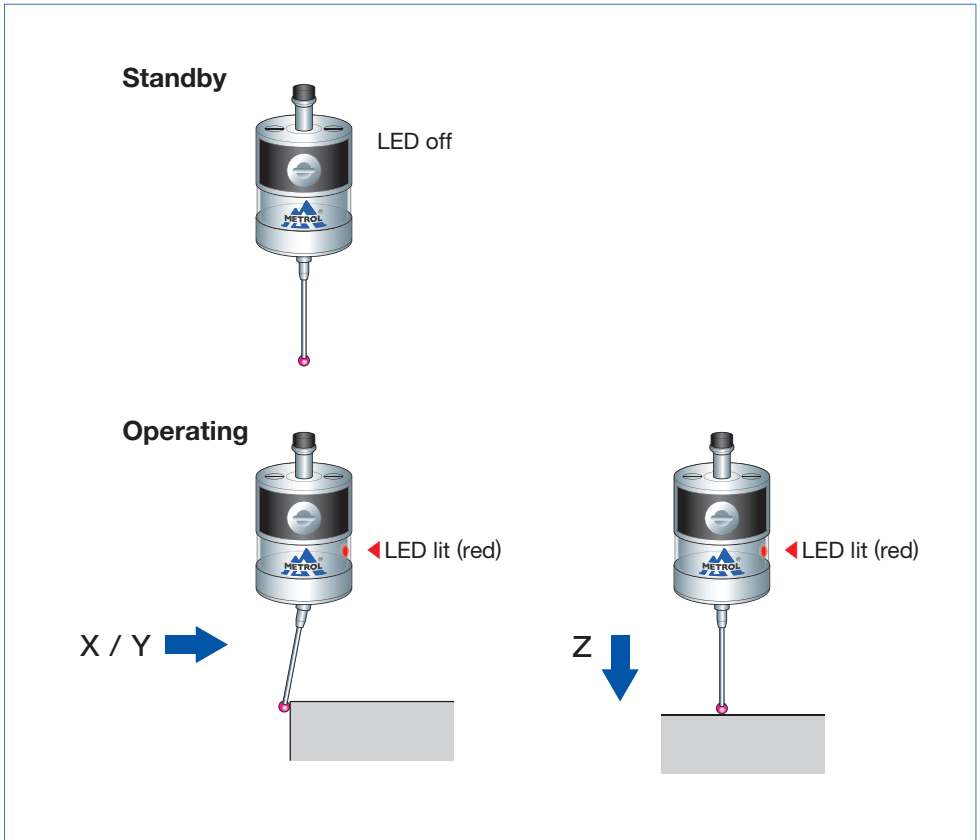

Note① : Due to the properties of the lithium-thionyl chloride battery, the following series of problems can occur if the low battery indication is ignored or overlooked.

1. The battery becomes worn down when the probe power is turned on, eventually preventing the probe from functioning properly.
2. Although the probe may no longer function, if left as is, the power of the probe may come back on if the battery is restored to a certain degree .
3. The battery becomes dead again and the probe no longer functions.
4. This series of events is repeated .

Note② : When the battery of the touch probe has remained dead (Batt. LED on the receiver is lit) for 3 hours or more, the entire system no longer functions.
In this case, replace the battery of the touch probe, unplug the cable from the receiver, and plug in the cable after waiting 10 seconds.
This will reset the system and restore system function.

4.Maintenance

■Cleaning the Probe

Wipe the window of the probe with a clean cloth to remove any cuttings and other debris. Clean the probe regularly to maintain the signal transmission capabilities of the probe in the optimum state.

■Battery Replacement

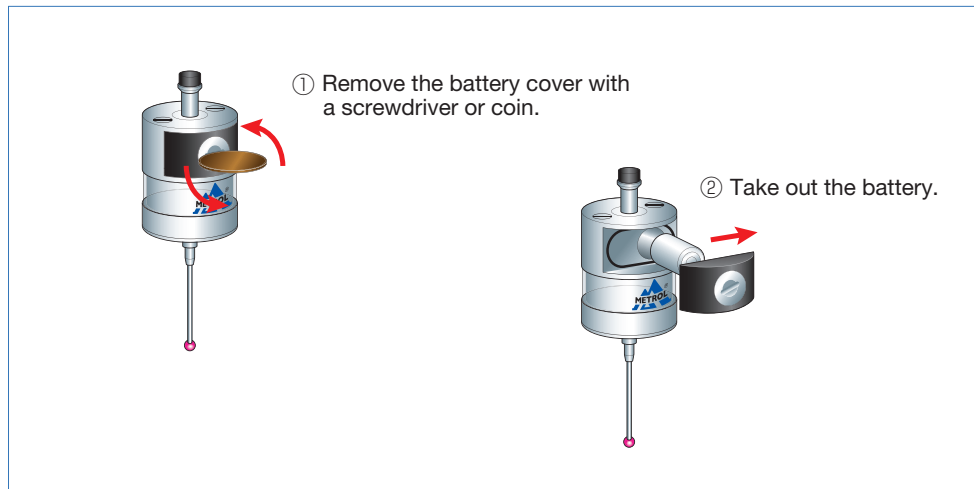

Caution:

- Confirm that the electrodes are correctly aligned when replacing the battery.
- The LED display will not light if a worn down battery is mistakenly inserted into the probe.
- Do not leave a worn down battery installed in the probe.
- Confirm that the battery cover seal has not been removed and use caution to prevent it from being damaged.
- Be careful so that coolant or cuttings do not get inside battery housing when replacing the battery.
- Before attaching the battery cover, check to make sure there is no damage or debris on the seal and its contact surface.
- Refer to page 3 for information on safe use of the battery.
- After having replaced a worn down battery, wait for at least 15 seconds before inserting a new battery.
- After attaching the cover, the LED will light for about 10 seconds. Do not touch the finger while the LED is lit. (If the finger is contacted while the LED is lit, the probe will enter the matching mode. If this happens, reinstall the battery.)

NOTE

Lined area for notes with horizontal dashed lines.

5.Troubleshooting

Problem	Possible Cause	Corrective Action
Probe power does not come on (LED display does not light or current probe settings are not displayed)	Dead battery	Replace the battery.
	Use of battery other than recommended battery	Replace the battery.
	Battery is installed improperly	Check the alignment of the electrodes of the battery.
	The time the battery has been removed is too short, preventing the probe from resetting	Wait for at least 15 seconds before installing a new battery.
Probe power does not come on	Dead battery	Replace the battery.
	Battery is installed improperly	Check the alignment of the electrodes of the battery.
	Not enough time allowed for communication following battery replacement	Check that the probe is within the allowable range of movement, and then wait for 1 or 2 minutes and try sending the power on signal again.
	Probe outside signal transmission range	Check the positional relationship between the probe and receiver (refer to P10).
	Start / stop signal not being transmitted from receiver (only when radio ON is selected)	Check whether or not the start LED on the receiver momentarily lights green.
Probe is in energy saving mode (only when radio ON is selected)	After confirming that the probe is within the range of movement, wait 1 to 2 minutes (the communication LED changes from flashing to lit after 1 to 2 minutes) and then try sending the power on signal again. Check the location of receiver (refer to system movement range).	
Machine stops at an unexpected location during the measurement cycle	Defective wireless communication / probe is outside signal transmission range	Check the position of the receiver and remove any obstacles.
	Problem with receiver or machine tool	Refer to the user's guide of the receiver or machine tool.
	Dead battery	Replace the battery.
	Probe unable to detect target measurement surface	Check whether workpiece is properly installed and secured and whether the finger has been damaged.
	Inadequate amount of time for stylus to become still following sudden deceleration	Insert a short dwell before each of the probe movement commands. (Dwell length varies according to stylus length and rate of deceleration.) The maximum dwell is 1 second.
Collision with probe	Workpiece present on probe movement path	Inspect the measurement software.

Problem	Possible Cause	Corrective Action
Defective repeatability or measurement accuracy	Debris present on workpiece or probe	Clean the workpiece and probe.
	Defective repeatability of seal replacement by ATC	Recalibrate the probe whenever the tool is changed.
	Inadequate coupling between probe and shank or loose finger	Check each location and retighten.
	Calibration value has not been updated or calibration value is incorrect	Inspect the measurement software.
	Difference in transmission rates between calibration and measurement	Inspect the measurement software.
	Measurement triggered by signal when finger leaves measurement surface	Inspect the measurement software.
	Measurement signal output during machine acceleration or deceleration	Inspect the measurement software.
	Feeding speed during measurement too fast or too slow	Test repeatability using various feeding speeds.
Receiver communication error LED lights during measurement cycle	Problem with machine tool	Inspect machine tool accuracy.
	Probe outside signal transmission range	Check the positional relationship between the probe and receiver (refer to P10).
Receiver battery alarm LED lights	Battery is worn down	Promptly replace the battery.
Signal transmission range excessively short	Interference by other wireless device	Identify and remove the source of the interference.
Probe power does not turn off	Power OFF signal not transmitted from receiver	Inspect the measurement software.
	Probe LED lights during processing.	Transmit the power OFF signal.
Probe LED flashing	The finger has been contacted while the probe LED is lit when replacing the battery (probe enters matching mode).	Reinstall the battery.
Com. LED flashes more than 5 minutes after machine power turned on	Probe outside signal transmission range	Check the positions of the probe and receiver (refer to P10).
	Problem with receiver	Please inquire to the manufacturer.

6.Parts List

Name		Model	Comments
① Set Type		RC-K3E-002-***S	Product number for all sets. Determined according to combination of finger, shank and direct output code.
② Sensor Head		RC-K3E-002-***H	Set number for ③+④+⑤+⑥+⑦. Determined according to finger.
③ Sensor Unit		RC-K3E-002HJ	Sensor body only
④ Finger		F-R40T-405	Standard finger (ruby ball Sφ4)
⑤ 1/2AA Lithium battery		BT-001-001	Recommended dedicated touch probe battery
⑥ Finger spanner		S907	Tool for fastening and removing finger
⑦ Finger wrench		HEX-0.89	Tool for fastening and removing finger
⑧ Shank	BT30	H-BT30-001	Shank BT30
	BT40	H-BT40-001	Shank BT40
⑨ Receiver		RC-R02-001	Receiver
⑩ Output Cable	5m	DC-R02-050	Cable 5m
	10m	DC-R02-100	Cable 10m

NOTE

Dotted lines for writing notes.

The specifications and descriptions are subject to change without notice due to improvements in products.

TOKYO JAPAN



Ultra-precision switches

METROL CO., LTD.

1-100 Takamatsu-cho Tachikawa, Tokyo 190-0011 JAPAN

Tel: +81 50 5558 7366 / Fax: +81 42 528 1442

E-mail: touchsensor@metrol.co.jp

GM-RCK3E-E-K003