

Quantos Automated Dosing Liquid Module

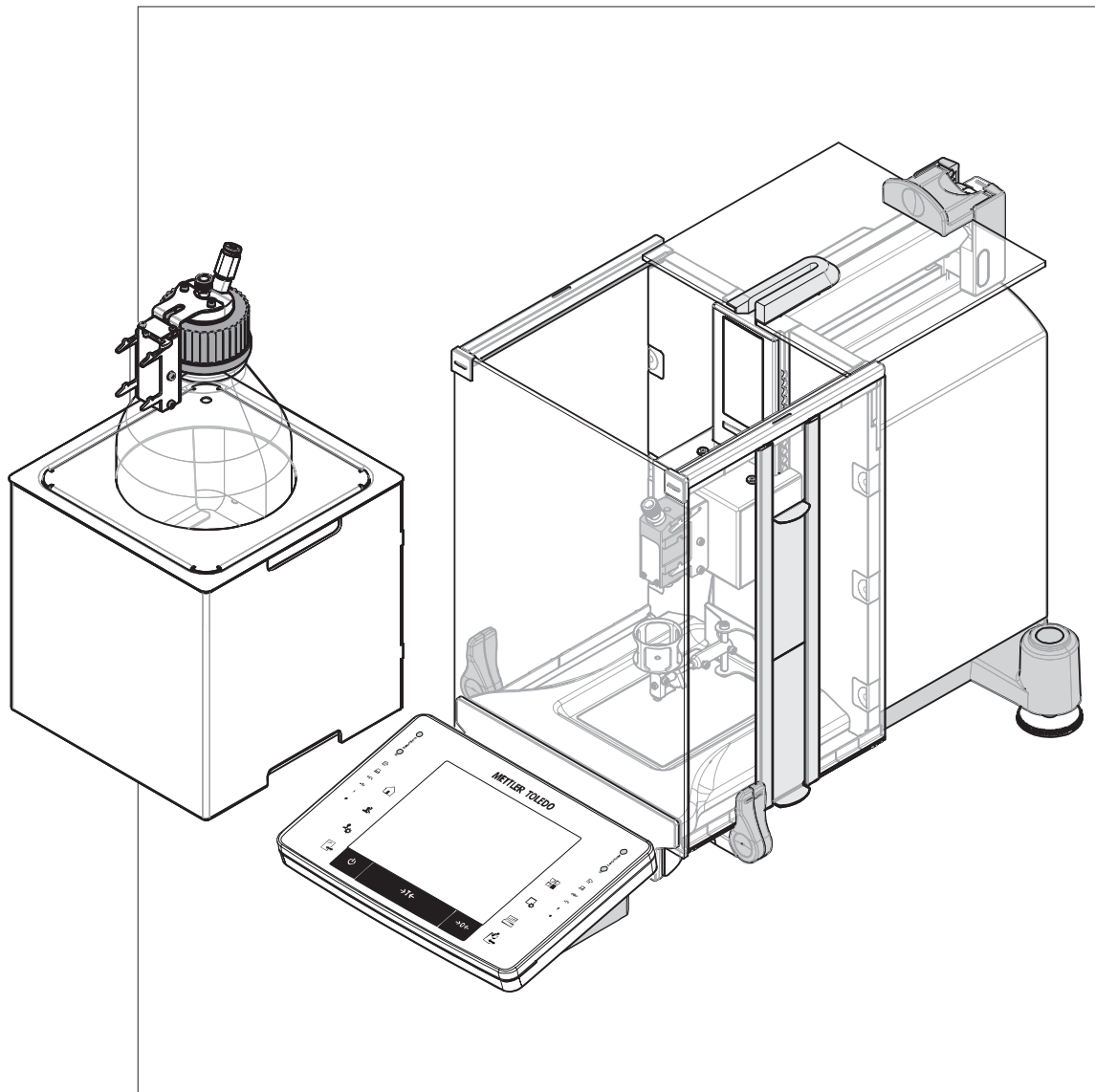

METTLER TOLEDO

Table of Contents

| | | | |
|----------|--|--|-----------|
| 1 | Introduction | | 3 |
| | 1.1 | Conventions and symbols used in these operating instructions | 3 |
| 2 | Safety Information | | 4 |
| | 2.1 | Definition of warnings and symbols | 4 |
| | 2.2 | Product specific safety notes | 4 |
| 3 | Design and Function | | 6 |
| | 3.1 | Overview | 6 |
| | 3.2 | Dosing head | 6 |
| | 3.3 | Data stored in the dosing head's RFID | 7 |
| 4 | Installation and Putting into Operation | | 8 |
| | 4.1 | Scope of delivery | 8 |
| | 4.2 | Location | 8 |
| | 4.2.1 | Selecting the location | 8 |
| | 4.3 | Assembling the liquid module | 9 |
| | 4.4 | Assembling pump module and bottle | 9 |
| | 4.6 | Connecting the tubes | 11 |
| | 4.7 | Wiring the liquid module | 13 |
| 5 | Operation | | 15 |
| | 5.1 | First steps | 15 |
| | 5.1.1 | Basic operation settings | 15 |
| | 5.1.2 | Working with liquid module | 15 |
| | 5.1.3 | Dosing liquid | 15 |
| | 5.1.4 | Dosing solution | 16 |
| | 5.1.5 | Releasing pressure | 17 |
| | 5.2 | Activating density | 17 |
| | 5.3 | Handling of liquid dosing head | 18 |
| | 5.3.1 | Displaying dosing head information | 18 |
| | 5.3.2 | Preparing a new dosing head for operation | 18 |
| | 5.4 | Handling of bottle | 19 |
| | 5.5 | Advanced features | 20 |
| | 5.5.1 | Working with sample counter | 20 |
| | 5.5.2 | Manual dosing | 21 |
| | 5.5.3 | Working with function MinWeigh | 21 |
| 6 | Maintenance | | 23 |
| | 6.1 | Installing new ferrule on liquid tube | 23 |
| | 6.2 | Cleaning the liquid module | 23 |
| | 6.3 | Disposal | 24 |
| 7 | Troubleshooting | | 25 |
| 8 | Technical Data | | 26 |
| | 8.1 | General data | 26 |
| | 8.2 | Explanatory notes for the METTLER TOLEDO AC adapter | 27 |
| | 8.3 | Model-specific data | 28 |
| | 8.4 | Dimensions | 29 |
| 9 | Accessories and Spare Parts | | 30 |
| | 9.1 | Accessories | 30 |
| | 9.2 | Spare parts | 32 |
| | Index | | 33 |

1 Introduction

Thank you for purchasing the Quantos dosing system.

Quantos is based on the renowned and reliable XPE series balances from METTLER TOLEDO. Besides the highly accurate dosing capabilities and ease of use, the Quantos provides connectivity to a variety of peripheral devices (e.g. barcode readers, label printers), and to a host computer.

This chapter contains basic information about the Quantos. Please read this chapter carefully, even if you already have experience with dosing systems or analytical balances.

Firmware version

The operating instructions are based on the initially installed terminal firmware (software) version V 2.00.

Finding more information

► www.mt.com/quantos

1.1 Conventions and symbols used in these operating instructions

For better readability the **Quantos Dosing System** is further referred to as **instrument**.

Key designations are indicated by a picture or text in square brackets (e.g. [] or [**Printer**]).

These symbols indicate an instruction:

- prerequisites
- 1 steps
- 2 ...
- ⇒ results

2 Safety Information

2.1 Definition of warnings and symbols

Signal Words

| | |
|------------------|--|
| WARNING | for a hazardous situation with medium risk, possibly resulting in severe injuries or death if not avoided. |
| CAUTION | for a hazardous situation with low risk, resulting in damage to the device or the property or in loss of data, or minor or medium injuries if not avoided. |
| Attention | (no symbol) for important information about the product. |
| Note | (no symbol) for useful information about the product. |

Symbols



General hazard



Electrical shock



Inflammable or explosive substance



Explosion

2.2 Product specific safety notes

Always operate and use your instrument only in accordance with the instructions contained in this manual. The instructions for setting up your new instrument must be strictly observed.

If the instrument is not used according to these Operating Instructions, protection of the instrument may be impaired and METTLER TOLEDO assumes no liability.



It is not permitted to use the instrument in explosive atmosphere of gases, steam, fog, dust and flammable dust (hazardous environments).



CAUTION

Damage of device

- For use only in dry interior rooms.
- Do not open the instrument: It does not contain any parts which can be maintained, repaired, or replaced by the user. If you ever have problems with your instrument, contact your METTLER TOLEDO dealer.
- Use only instrument accessories and peripheral devices from METTLER TOLEDO; they are optimally adapted to your instrument.



CAUTION

Damage of Device

Use only the original universal AC adapter delivered with your instrument.

Certain samples require special care!

With certain types of samples, there is a possibility of danger to personnel or damage of property. Please note that the user always has the responsibility and liability for damage caused by use of any types of samples!



CAUTION — Fire or Explosion

- Flammable or explosive substances.
 - Substances containing solvents.
1. In cases of doubt, perform a careful risk analysis.
 2. Working temperature that is low enough to prevent the formation of flames or an explosion.
 3. Wear protective glasses.

Intended use

Your liquid module is used for weighing and dosing liquid samples. Use the instrument exclusively for this purpose. Any other type of use and operation beyond the limits of technical specifications without written consent from Mettler-Toledo AG, is considered as not intended.

FCC / IC Statement

This device complies with Industry Canada licence-exempt RSS standard(s) and part 15 of the FCC Rules. Operation is subject to the following two conditions:

- (1) this device may not cause interference, and
- (2) this device must accept any interference, including interference that may cause undesired operation of the device.

Le présent appareil est conforme aux CNR d'Industrie Canada applicables aux appareils radio exempts de licence. L'exploitation est autorisée aux deux conditions suivantes :

- (1) l'appareil ne doit pas produire de brouillage, et
- (2) l'appareil doit accepter tout brouillage radioélectrique subi, même si le brouillage est susceptible d'en compromettre le fonctionnement.

Changes or modifications not expressly approved by the party responsible for compliance could void the user's authority to operate the equipment.

This equipment has been tested and found to comply with the limits for a Class A digital device, pursuant to part 15 of the FCC Rules. These limits are designed to provide reasonable protection against harmful interference when the equipment is operated in a commercial environment. This equipment generates, uses, and can radiate radio frequency energy and, if not installed and used in accordance with the instruction manual, may cause harmful interference to radio communications. Operation of this equipment in a residential area is likely to cause harmful interference in which case the user will be required to correct the interference at his own expense.

3 Design and Function

3.1 Overview

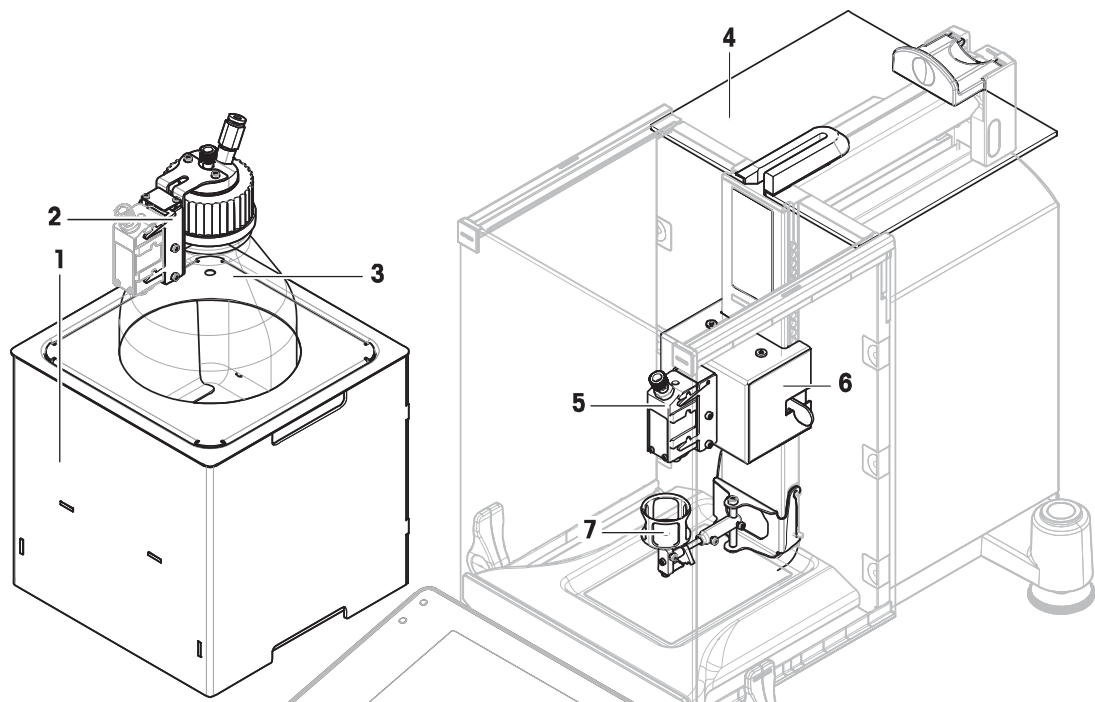

| Pump module with bottle | | Liquid kit with liquid dosing head | |
|-------------------------|----------------------------|------------------------------------|----------------------------|
| 1 | Pump module (QL2) | 4 | Top glass liquid |
| 2 | Liquid dosing head support | 5 | Liquid dosing head (QL001) |
| 3 | Bottle | 6 | Liquid kit (QLX45) |
| | | 7 | ErgoClip vial |

3.2 Dosing head

Liquid dosing head

This is the standard head for liquid dosing. It is used together with pump module and bottle.

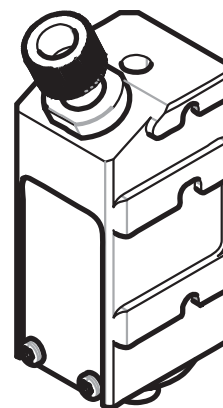

Manual dosing head

The manual dosing head is used for manual powder dosing. It is equipped with a RFID chip to store substance data and to provide printing data.

Functional description

As soon as a head is inserted, the instrument automatically reads the data of the head. In addition, the instrument performs automatic adjustments concerning the **Dosing steps**, automatic door operation and other instrument settings.

When no dosing head is installed the instrument will replace head-specific information with factory settings.

See also

📖 Working with function MinWeigh [▶ 21]

3.3 Data stored in the dosing head's RFID

Every dosing head is equipped with a Radio Frequency Identification chip (RFID) (1) that can store and exchange data with the instrument.

The following data is stored in the RFID of the head:

- **User data**

This block holds information about the substance such as the name of the substance, the filling and expiry dates, the quantity, etc. This data can be edited by the user at any time and it should be entered before using a new head for the first time to ensure proper functioning of the instrument's internal monitoring routines, and to have the data available for reports and labels.

- **Internal data**

This block holds information about the remaining amount of substance left in the container. This block of data cannot be modified by the user.

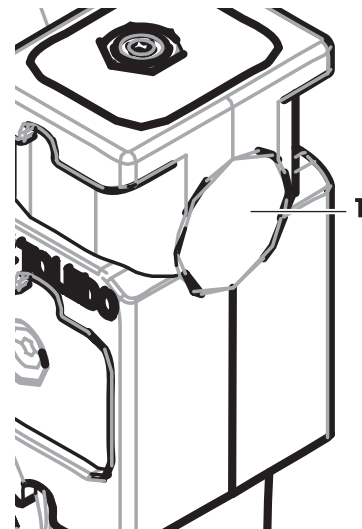

4 Installation and Putting into Operation

Installation

Note

The instrument is installed by METTLER TOLEDO service engineers. This includes the wiring as well as the configuration of the interfaces and peripherals.

4.1 Scope of delivery

Liquid module

Check the delivery for completeness. The following accessories are part of the standard equipment of the liquid module:

- **Liquid kit QLX45**
 - Liquid kit QLX45
 - Top glass liquid
 - ErgoClip vial
 - Weighing pan liquid
 - Vial adapter 5 pcs
 - MinWeigh door
 - Screwdriver torx T8
 - RS232C-cable
 - RFID transponder 5 pcs
 - Power supply
 - Cable conduct
 - Cable clip (cable conduct closure)
 - Quick Guide
- **Liquid Bottle and Head QLL1000**
 - Liquid head QL001
 - Bottle 1000 ml pressure
 - Bottle cap with fitting and support
 - Micro dosing valve tool
 - Spare part set (incl. filter, ferrule, peek nut)
 - Liquid tube
 - Air tube
- **Pump module QL2**
 - Muffler
 - Bottle holder
 - Drip pan
 - CAN-cable
 - CE declaration of conformity

Recommended Options

- Ethernet Option
- Ethernet / RS232 (Netcom kit)
- AntiStatic kit
- Cable box

4.2 Location

4.2.1 Selecting the location

Select a stable, vibration-free position that is as horizontal as possible. The surface must be able to safely carry the weight of a fully loaded instrument.

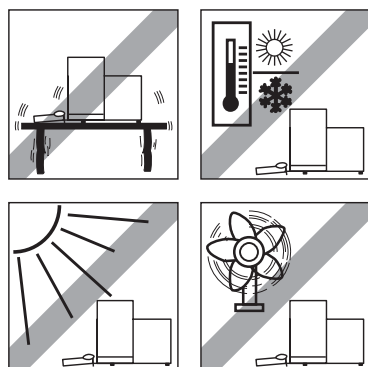

Observe ambient conditions.

Avoid the following:

- Vibrations
- Excessive temperature fluctuations
- Direct sunlight
- Powerful drafts (e.g. from fans or air conditioners)

See also

 Technical Data [[▶ 26](#)]

4.3 Assembling the liquid module

- Assemble the balance according to your XPE Operating Instructions.
- Remove top glass (1) by sliding it backwards and pulling it upwards (2) carefully.

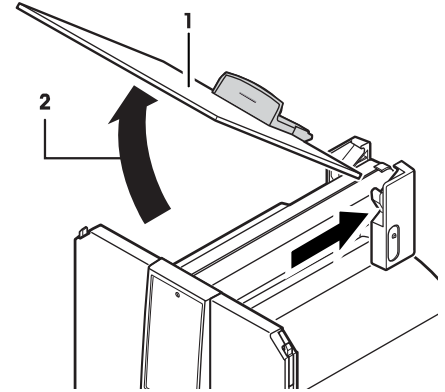

- Note**
CAN-connector is on bottom of liquid kit.
To insert the liquid kit (1), pull 2 levers (2) towards you and slide liquid kit onto the rack.
- To fix position of liquid kit, release 2 levers (2) and move liquid kit slightly.
 - ⇒ Liquid kit locks down.
 - ⇒ Liquid kit is mounted.

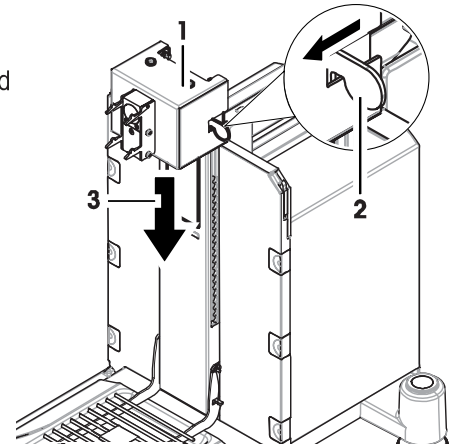

Note

If MinWeigh side door is available, remove side door and insert MinWeigh side door.

- Insert the top glass liquid (1) into the rear guide.
- Carefully fold top glass liquid (2) downwards.

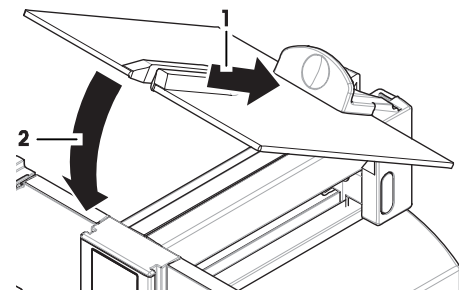

4.4 Assembling pump module and bottle



CAUTION

Damage of Bottle because of high pressure!

If the bottle has to resist higher pressure than 1.5 bar (21 psi) it might get damaged.

- Do not allow pressure higher than 1.5 bar (21 psi) in the bottle.
- Wear protective glasses when working with the bottle.

- Mount pump module and bottle according to figure.

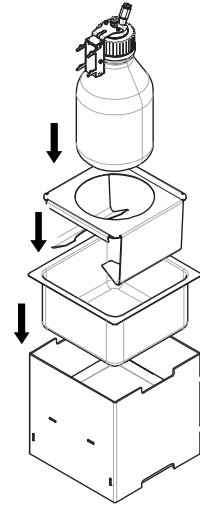

Inserting and removing liquid dosing head in and from the liquid dosing head support

- 1 Insert liquid dosing head in the liquid dosing head support.

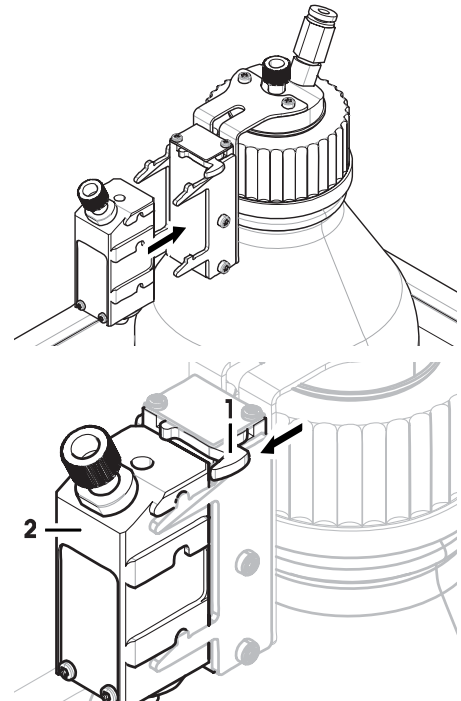

- 2 To remove liquid dosing head from the liquid dosing head support, pull the catch (1) to the front and remove liquid dosing head (2).

4.5 Installing liquid dosing head on liquid kit

Installing liquid dosing head on liquid kit

- 1 Slide the liquid dosing head (1) onto the liquid kit (2) until it comes to a stop.
- 2 Press it down slightly until it is properly seated in the holding pins.

Note

Check that dosing head is inserted correctly.
If there is just a small gap between dosing head and its support, press it down again.

- 3 Thread the liquid tube through slot in Quantos top glass.

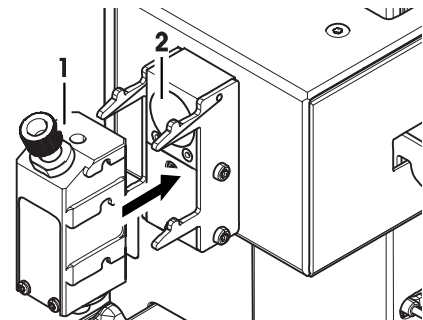

Removing liquid dosing head from liquid kit

- To remove the liquid dosing head, press it slightly upwards and remove it to the front.

4.6 Connecting the tubes

Connectors of pump module

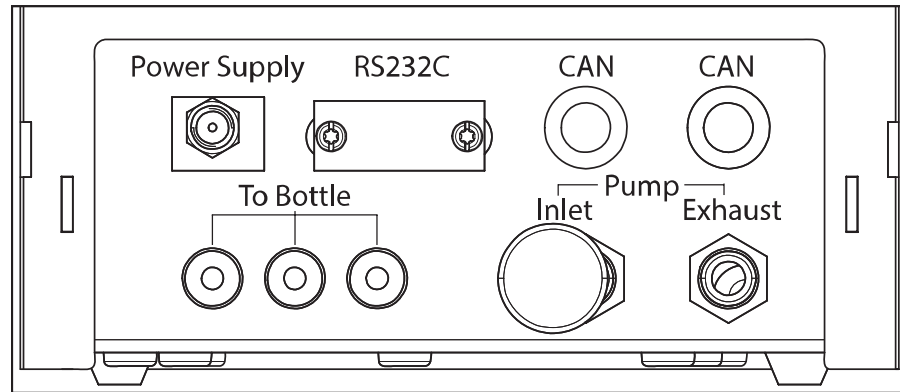

⚠ CAUTION

Dangerous liquids!

- If you use toxic, explosive or flammable liquids, the exhaust air will be contaminated.
- Use a tube for the exhaust air outlet.



⚠ CAUTION

High pressure!

If you feed pump with a protective gas with pressure higher than 0.2 bar (2.9 psi), the pump module might get damaged.

- 1 Make sure the protective gas does not exceed the pressure range of 0.2 bar (2.9 psi).
- 2 Wear protective glasses when handling the protective gas.

Note

The thinner tube is used for transporting liquid from the bottle to the liquid dosing head. The slightly bigger tube is used for pumping air into the bottle. By adding air, pressure rises in the bottle. When pressure reaches min. 0.3 to max 0.5 bar (4.4 to 7.2 psi) the micro dispensing valve in the dosing head opens and liquid can ascend the liquid tube. The two tubes are further referred to as liquid tube and air tube.

- The liquid dosing head is inserted in the liquid dosing head support.
- 1 Connect liquid tube at bottle and at liquid dosing head.

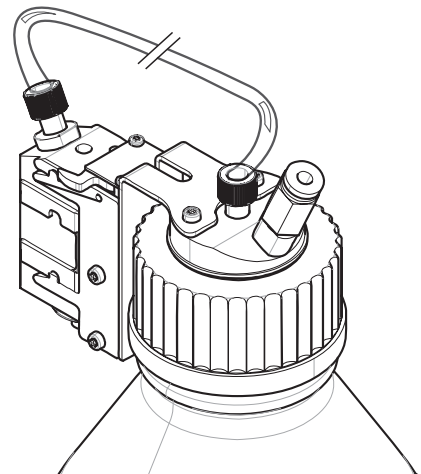

- 2 Connect air tube at bottle and at pump module.

Note

A tube in the air outlet to bottle opens the valve of the air outlet. Never leave a tube which is connected to the air outlet unconnected at the other end because pressure can not be built up.

You can connect up to 3 bottles to the pump module. The instrument uses the liquid of the bottle, which is inserted in the pump module.

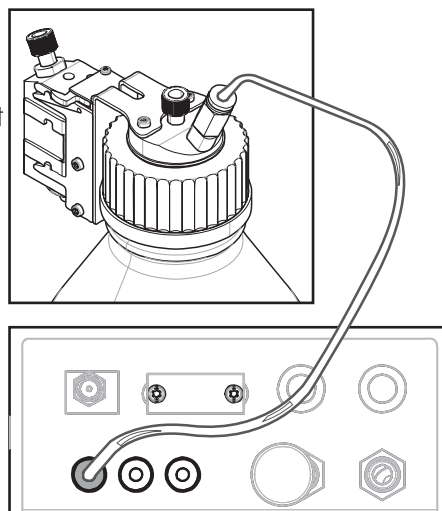

- 3 Insert muffle (1) into air inlet to absorb noise.

- 4 **WARNING Explosion hazard!**

If you need to feed the pump with protective gas, e.g. nitrogen, make sure it does not exceed the pressure range of 0.2 bar (2.9 psi).

Wear protective glasses.

Do not insert muffle (1) but instead connect a tube to the air inlet.

Note

Outer tube diameter: 6 mm

Pressure range: 0.1 ... 0.2 bar (1.5 ... 2.9 psi)

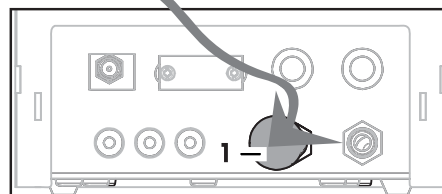
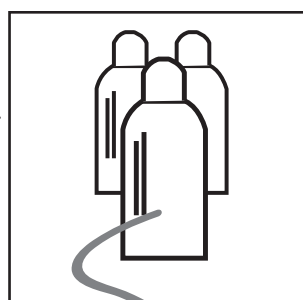

- 5 **WARNING Contaminated air!**

If you use toxic, explosive or flammable liquids, the exhaust air will be contaminated and the device can get damaged. Connect a tube to exhaust air outlet to absorb the air into a safe container.

Note

Outer tube diameter: 6 mm

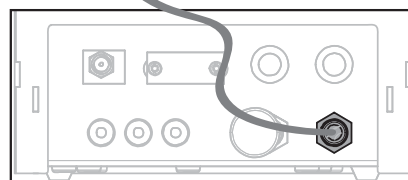
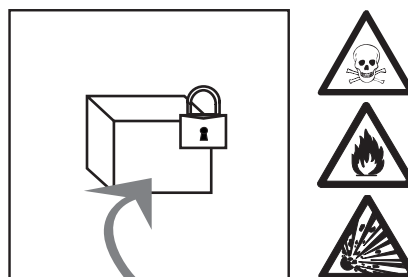

NOTICE

Damage on tube connectors because of mishandling!

If the tubes are not removed correctly, the connectors and therefore the pump module can get damaged.

- To remove tubes, press down ring on connector and pull out tube carefully.

4.7 Wiring the liquid module



WARNING

Risk of electric shock

- 1 To connect the pump module, only use the supplied three-core power cable with equipment grounding conductor.
- 2 Only connect the pump module to a three-pin power socket with earthing contact.
- 3 Only standardized extension cable with equipment grounding conductor must be used for operation of the pump module.
- 4 Intentional disconnection of the equipment grounding conductor is forbidden.

The balance is supplied with an AC adapter and country-specific power cable. The AC adapter is suitable for use with the following voltage range:

100 – 240 V AC, 50/60 Hz.

Attention

- Check whether your local power supply falls within this range. If this is not the case, under no circumstances connect the AC adapter to the power supply, but contact a METTLER TOLEDO representative.
- The power plug must be accessible at all times.
- Prior to use, check the power cable for damage.
- Route the cable in such a way that it cannot be damaged or cause a hindrance when working.
- Ensure that no liquid comes into contact with the AC adapter.

Note

Also **see** XPE Operating Instructions for further information.

Note

Wire the components before turning the balance on.

After turning the balance on, if the message **Wrong head type mounted** appears, check wires.

Make sure you connect CAN-cables before connecting power supplies.

Connectors of pump module

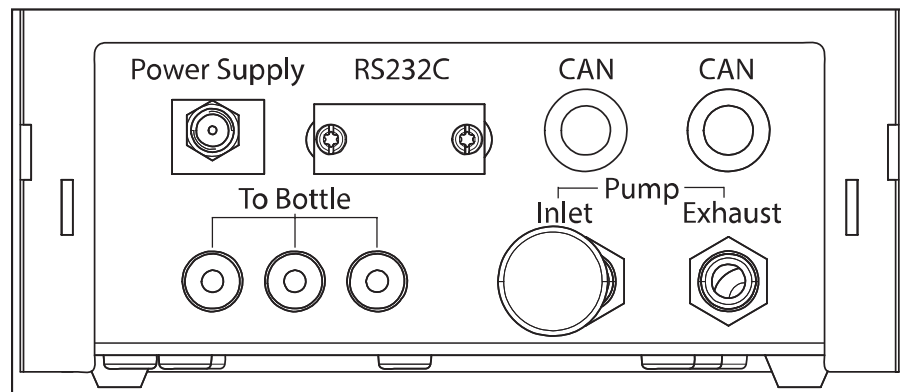

Note

Power supply and RS232C-connector are covered with a faceplate. Remove faceplate.

- 1 Connect pump module with liquid kit via CAN-cable.

Note

There are 2 CAN-connectors on the pump module. There is no preference which one to take.

- 2 Remove left side glass and exchange one clip with the cable clip included in the scope of delivery.
- 3 Guide CAN-cable through cable clip and insert left side glass.

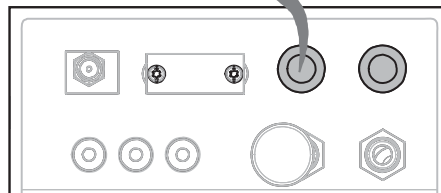
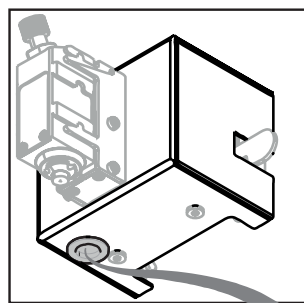

- 4 Connect pump module with balance via standard RS232C-cable.

⇒ Liquid module is connected.

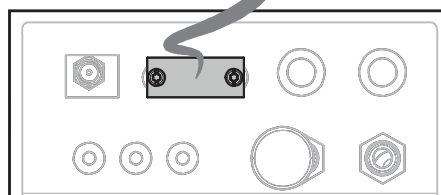
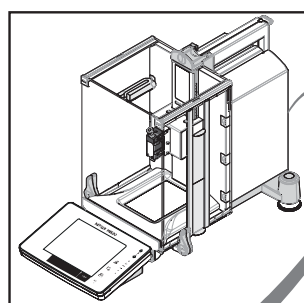

- 1 Connect power cable of liquid module to power socket and local power supply.

- 2 Connect power cable of balance to power socket and local power supply according to the XPE Operating Instructions.

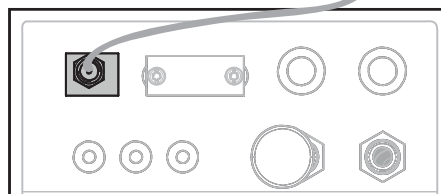
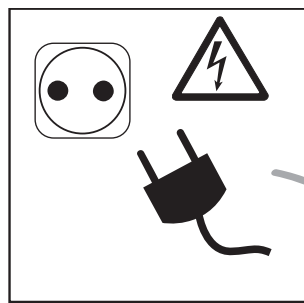

5 Operation

5.1 First steps

5.1.1 Basic operation settings

Note

If you dose liquid for the first time, or after a master reset, check following settings:

- Dosing must be chosen as application: [F6] > [Dosing]
- Liquid module must be defined as mounted: [F4] > **Liquid module...** [Define] > [Mounted]
- Powder module must be defined as unmounted: [F4] > **Powder module...** [Define] > [Unmounted]
- RS232 device must be activated: [F6] > [System] > [Peripherals] > **RFID / Quantos...**[RS232 built-in] > [RS232 built-in]

Configure your settings in the following menu:

Navigation: [F4] > **Liquid module...** [Define] > **Mounted...** [Define]

Note

Refer to your XPE Operating Instructions for further information on settings and parameters.

5.1.2 Working with liquid module

If you tap [Start] with the liquid module, you get these options:

| | | | |
|---|-----------------|--|-----------------------------------|
|  | [Solution] | To prepare a solution with defined concentration solid/liquid in mg/g . | See [Dosing solution ▶ 16] |
| | [Solid dosing] | To dose a powder. | See [Manual dosing ▶ 21] |
| | [Liquid dosing] | To dose a liquid. | See [Dosing liquid ▶ 15] |
| | [Cancel] | To return to home screen. | |

See also

- 📖 Dosing liquid [▶ 15]
- 📖 Manual dosing [▶ 21]
- 📖 Dosing solution [▶ 16]

5.1.3 Dosing liquid

Note

The following procedure is described according to the standard factory settings. You can customize or disable the settings in the following menu:

[F4] > **Dosing steps...** [Define] > **Dosing steps (liquid)...** [Define]

To recreate the standard factory settings, choose [STD].

Note

To abort dosing procedure at any time, tap the cancel key [C].

The instrument then returns to the home screen.

- Liquid dosing head is installed.
- Weighing pan is empty.
- If required, ErgoClip is installed.

- 1 Tap [Start] > [Liquid dosing].
- 2 Enter **User ID** and confirm with [OK].

3 Note

The **Sample ID** is not mandatory and the instrument does not check whether or not it is unique.

Enter **Sample ID** and confirm with [OK].

- 4 Enter the amount **Target liquid [g]** required and confirm with [OK].
- 5 Place sample vessel on weighing pan or ErgoClip and confirm with [OK].

6 Lower position of dosing head until it is about 0.5 mm to 1 mm above the sample vessel and confirm with [OK].

7 **Note**

To abort dosing during process, tap [C].

Check, if all necessary adjustments are completed:

To abort procedure, tap [No].

To start dosing, tap [Yes].

⇒ Pressure builds up.

⇒ Instrument doses liquid.

⇒ The results are being displayed.

8 To finish dosing process, confirm with [OK].

Congratulations, you have just successfully finished your first dosing!

Note

- Bubbles in the tube do not impair the result, because the target result is weighed.
- If you dose liquids that might crystalize, clean the dosing head from time to time.

See also

📖 Cleaning the liquid module [▶ 23]

5.1.4 Dosing solution

Solution dosings work with a concentration **not** measured by volume [ml], but by weight [mg].

Concentration

To calculate the concentration (C):

$$C = \text{mass of solid} / (\text{mass of solid} + \text{mass of liquid})$$

Dosing powder manually

If you have few solid samples you can leave the liquid dosing head installed.

Note

The following procedure is described according to the standard factory settings: [☰] > **Dosing steps...**

[Define] > **Dosing steps (solution)**...[Define] > [STD]

- Liquid dosing head is installed.
 - Weighing pan is empty.
- 1 Tap [Start] > [Solution] > [Start manual dosing].
 - 2 Enter **Substance** and confirm with [OK].
 - 3 Enter **Lot ID** of substance and confirm with [OK].
 - 4 Enter **User ID** and confirm with [OK].
 - 5 Enter **Sample ID** and confirm with [OK].
 - 6 Enter **Concentration [mg/g]** and confirm with [OK].
 - 7 Enter **Target solution [g]** and confirm with [OK].
 - 8 Place sample vessel on weighing pan and confirm with [OK].
 - 9 Dose manually the needed powder and confirm with [OK].
 - ⇒ Dosing results are displayed.
 - 10 Confirm results with [OK].
 - 11 To start liquid dosing tap [OK].
 - ⇒ Instrument doses liquid.
 - 12 Cap vessel and confirm with [OK].
 - ⇒ Dosing results are displayed.
 - 13 Confirm results with [OK].

Dosing solution with pre-prepared solid

If you have sample vessels with already prepared solid e.g. a tablet you can leave the liquid dosing head installed.

Note

The following procedure is described according to the standard factory settings: [F5] > **Dosing steps...** [Define] > **Dosing steps (solution)...** [Define] > [STD]

- Liquid dosing head is installed.
 - Mass of solid is known.
 - Weighing pan is empty.
- 1 Tap [Start] > [Solution] > [Enter predosed quantity].
 - 2 Enter the weight of the pre-dosed solid in **Enter predosed quantity** and confirm with [OK].
 - 3 Enter **Concentration [mg/g]** and confirm with [OK].
 - 4 Enter **Substance** and confirm with [OK].
 - 5 Enter **Lot ID** of substance and confirm with [OK].
 - 6 Enter **User ID** and confirm with [OK].
 - 7 Enter **Sample ID** and confirm with [OK].
 - 8 Place sample vessel on weighing pan and confirm with [OK].
 - 9 **Note**
To abort dosing during process, tap [C]
Check, if all necessary adjustments are completed:
To abort procedure, tap [No].
To start dosing, tap [Yes].
⇒ Pressure builds up.
⇒ Instrument doses solid.
 - 10 Cap sample vessel and confirm with [OK].
⇒ The results are being displayed.
 - 11 To finish dosing process, confirm with [OK].

5.1.5 Releasing pressure

If you need to release the pressure in e.g. the bottle, switch off the instrument.

Switching Off

- Press [Power] until **Off** appears in the display.

Note

Do not disconnect the instrument from the power supply except if you will not be using the instrument for an extended period.

5.2 Activating density

Quantos works gravimetric. Users who work with liquids normally think volumetric and need the parameter of density.

Activating and printing density for liquids

Formula: Volume [ml] = Mass [g] / Density [g/ml]

- 1 Activate [F5] > **Dosing steps...** [Define] > **Dosing steps (liquid)...** [Define] > [Density param.].
- 2 Activate [F5] > **Data output...** [Define] > **Sample label...** [Define] > **Text (liquid dosing)...** [Define] > [Density param.].
- 3 To print the volume, activate [F5] > **Data output...** [Define] > **Sample label...** [Define] > **Text (liquid dosing)...** [Define] > [Liquid vol.].

Activating and printing density for solutions

Formula: Concentration volumetric [mg/ml] = Concentration gravimetric [mg/g] x Density [g/ml]

- 1 Activate [☰] > **Dosing steps...** [Define] > **Dosing steps (solution)...** [Define] > [Density param.].
- 2 Activate [☰] > **Data output...** [Define] > **Sample label...** [Define] > **Text (solution)...** [Define] > [Density param.].
- 3 To print the volume, activate [☰] > **Data output...** [Define] > **Sample label...** [Define] > **Text (solution)...** [Define] > [Vol. conc.].

5.3 Handling of liquid dosing head

5.3.1 Displaying dosing head information



The menu [**Info head**] displays information stored in the current dosing head.

- Function key [**Info head**] is active.

- 1 Tap [**Info head**].

⇒ The display shows the data stored in the dosing head.

Note

The amount of data displayed depends on the menu settings.

See XPE Operating Instructions for information on defining the output of dosing head data.

- 2 To return to the main window, tap [**OK**].

5.3.2 Preparing a new dosing head for operation

Note

The amount of user data that is required for setting up a dosing head is customizable. You can shorten the procedure.

See XPE Operating Instructions for information on setting up the head definition data.

Entering head data



- Function key [**Write head**] is active.

- 1 Tap [**Write head**].

⇒ The window **Substance** appears.

- 2 **Note**

If a barcode reader is connected to your instrument and your substance provides a barcode, scan the product barcode instead of entering the name manually. The name of the substance appears in the respective information field and can be printed on the dosing reports or labels. Enter the name of the substance and confirm with [**OK**].

(max. of 20 characters)

⇒ The window **Lot ID** appears.

- 3 Enter the **Lot ID** of your substance and confirm with [**OK**].

(max. of 15 characters)

⇒ The window **Filling date** appears.

- 4 Enter the **Filling date** of your substance and confirm with [**OK**].

⇒ The window **Exp. date** appears.

- 5 **Note**

Once the **Exp. date** is reached an error message appears and you will not be able to continue dosing.

Enter the **Exp. date** of your substance and confirm with [**OK**].

⇒ The window **Content [mg]** appears.

- 6 Enter the noted value in [g] and confirm with [**OK**].

Note

With this value the counter calculates the remaining amount of substance.

The following two windows are for the first customizable field called **ID1** which may be used for entering additional data, e.g. about your substance or your company.

Note

In the course of this manual the default titles **ID1** and **Value 1** will be used.

- 7 Select **ID1 Name** which is the title of the first customizable field.
- 8 Change this identification and confirm with **[OK]**.
Factory setting: **ID1** (variable 1).
(max. up to 10 characters)
Example: If you want to save the storage temperature of 5 °C, enter **Storage**.
 - ⇒ The new title will appear in the respective information field and on the labels and reports you print.
 - ⇒ The window **ID1** appears.
- 9 Enter the contents of the first customizable field and confirm with **[OK]**.
Factory setting: **Value 1**
(max. 15 characters)
Example: If you want to save the storage temperature of 5 °C, enter **5oC** and confirm with **[OK]**.
 - ⇒ The instrument writes the user data to the head and then a message of successful data transfer appears.
 - ⇒ If a label printer is connected and automatic printing is selected, a label will be printed. Affix it to the dosing head.
 - ⇒ If no automatic label printing takes place, press  while the message is displayed.
- 10 To return to the main window, confirm with **[OK]**.
 - ⇒ The new head is ready for dosing.

Note

The following information is not part of the default head definition sequence. If you want these fields to appear when preparing a new head, select them.

See XPE Operating Instructions for information on setting up the head definition data.

[ID2] There are 3 additional customizable fields called **ID2**, **ID3** and **ID4**, for entering the respective title and contents.

- Retest date**
- 1 Enter the **Retest date** of your substance. Once the retest date is reached a warning appears. You can decide to continue or to abort dosing. If you abort dosing, test your substance.
 - 2 Confirm with **[OK]**.

5.4 Handling of bottle

Changing a bottle

If you have more than one bottle equipped with cap and dosing head:

- Pressure is released.
- 1 Install dosing head on dosing head support at the bottle.
 - 2 Unplug air tube by pressing ring (1) down and pulling tube (2) out carefully at the same time.
 - 3 To seal the bottle, insert pin into air tube fitting.
 - 4 Take the new bottle.
 - 5 Connect air tube to new bottle.
 - 6 To continue dosing with the new bottle, install dosing head.

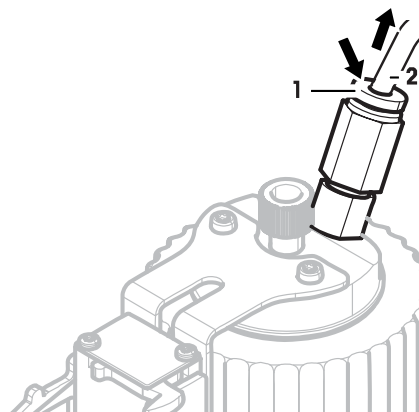

Filling bottle

The Inline frit filter has to be covered with liquid at all times. Before the inline frit filter gets dry, refill the bottle.

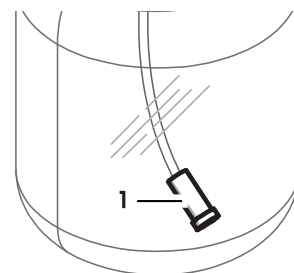

- Pressure is released.
- 1 Unscrew regular cap.
- 2 Fill in the liquid. (max. is shown on bottle e.g. 1000 ml)

Note

Do not exceed the maximum. The air above the liquid is necessary for dosing.

- 3 Screw on cap.
- 4 Check that the cap is tight.

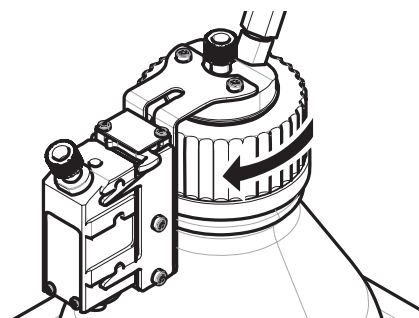

Changing the liquid of bottle

You have just one cap with dosing head and want to change the liquid:

- Pressure is released.
- 1 Unplug air tube.
- 2 Unscrew regular cap.
- 3 Unscrew inner PEEK nut.
- 4 Change the inner tube and the inline frit filter.
- 5 Screw the regular cap on new bottle.
- 6 Check that the cap is tight.
- 7 Connect air tube to new bottle.
- 8 Purge the contaminated external tube.

See also

- 📖 Cleaning the liquid module [► 23]

5.5 Advanced features

5.5.1 Working with sample counter

The sample counter is meant to assist you when dosing a given number of samples.

- Function key **Samples** is active.
- If you work with the sample counter, select the corresponding information fields.
- 1 Tap [**Samples**].
 - ⇒ A numeric input field appears.
- 2 If you enter a value between 1 and 1000, you activate the sample counter. Factory setting = "0": sample counter is switched off.
- 3 Dose first sample.
 - ⇒ After dosing is completed the counter has decreased by 1.
 - ⇒ At the end **Last sample reached** appears.

- 4 Confirm with **[OK]**.
⇒ The instrument resets both values to zero.

5.5.2 Manual dosing

In some cases the dosing head may not be able to dose a particular substance properly or you want to dose a solid e.g. tablets or wax. In such a case you can revert to manual dosing. The dosing procedure is almost the same as in automatic mode except that you do the dosing.

- 1 Install manual dosing head.
⇒ The instrument reads dosing head.
- 2 Tap **[Start]** > **[Solid dosing]**.
- 3 Enter all required data.
- 4 Put sample vessel on weighing pan and confirm with **[OK]**.

Dosing powder

- 5 Dose the powder into the sample vessel manually.
⇒ The SmartTrac cross-hair graph assists you. This is the coarse range indicator that helps you dosing the powder quickly until you approach the target area. As soon as the vertical bar (fine range indicator) starts moving to the right you should slow down the dosing procedure and carefully approach the target value in the middle between the two tolerance marks.

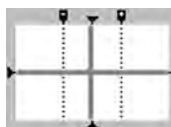

- 6 If the target quantity is reached, confirm with **[OK]**.
⇒ The result of the manual dosing appears.
⇒ The label and/or record are printed. The validity item is followed by M stating that this was a manual dosing.

See also

 Dosing liquid [▶ 15]

5.5.3 Working with function MinWeigh

The **MinWeigh** function ensures that the sample weight does not go below a certain limit (in reference to the tare weight) in order to meet the admissible tolerance for the measured values. The **MinWeigh** function must be mounted and programmed by a service engineer.



As soon as **MinWeigh** is installed, the status icon appears in the upper right corner of the display. This icon and the light color of the weight value indicate that the minimum initial weight value has not yet been reached and that the current weight value may be outside the tolerance range specified in the quality assurance system.

Example

When working according to GMP the admissible tolerance is 1%, $k=2$, while the more restrictive USP standard allows for 0.10%, $k=2$.

Now start dosing as usually. While dosing, the weight value first appears in a light color indicating that the minimum initial weight has not yet been reached. As soon as the minimum weight is reached, the color of the weight value turns solid and the status icon disappears.

Note

If several reference tare values (and their corresponding minimum initial weight values) have been programmed by the service engineer, the required minimum initial weight value changes automatically, depending on the tare weight.

At the end of the dosing cycle the result of the **MinWeigh** function will be shown at the bottom of the display:

- **VALID** (result is in tolerance)
- **INVALID** (result is out of tolerance)

If you include **MinWeigh** in your sample labels and/or records the result will also appear in the printout.



Note

If the status icon **MinWeigh test** appears, contact the customer service department. A service engineer runs the **MinWeigh** test as soon as possible.

6 Maintenance

Note

Also see XPE Operating Instructions for further information.

6.1 Installing new ferrule on liquid tube



CAUTION

Splashing liquids because of remaining pressure in dosing head!

If you don't release the pressure of the dosing head, liquid might splash when opening dosing head or removing liquid tube.

- 1 Always release pressure of dosing head by opening the bottle before removing liquid tube.
- 2 Wear protective glasses.

Note

If the liquid tube is leaky, replace ferrules. There are 3 ferrules, located one each at the seals of the liquid tube.

- 1 To release pressure of dosing head, open bottle.
- 2 To access the ferrule, slide PEEK nut (1) back.
- 3 Cut off ferrule (2). Check that the end of the tube is straight.
- 4 Thread PEEK nut.
- 5 Thread new ferrule. Check that the face of the ferrule is alligned to the face of the tube.
- 6 To fasten ferrule, screw PEEK nut tight.

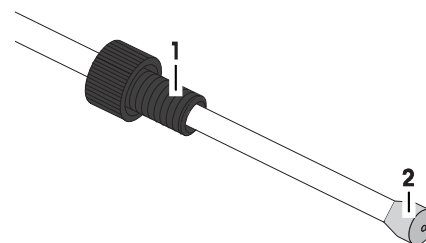

6.2 Cleaning the liquid module

Your instrument is made from high quality, resistant materials and can therefore be cleaned with a commercially available, mild cleaning agent. If your flow rate is decreasing, clean your instrument.

- 1 Remove liquid bottle, bottle holder and drip pan.
- 2 Clean all items.
- 3 Reinstall all items.

Suction Filter

- 1 **Once a week**, check visually that the suction filter is clean.
- 2 At least **once a year**, change suction filter. Maintenance interval depends on the liquid used.

Purging the liquid dosing head



- Check that the liquid sample vessel is big enough for your **Purge time [sec]**.
 - 1 Tap [**Purge**].
 - 2 Place sample vessel and confirm with [**OK**].
 - ⇒ **Purge time [sec]** opens.
 - 3 Based on the liquid you used, enter purge time in [sec] and confirm with [**OK**].
 - ⇒ Pressure builds up.
 - ⇒ Instrument purges.

Cleaning the liquid dosing head

If purging is not enough, clean the liquid dosing head as follows.



CAUTION

Splashing liquids because of remaining pressure in dosing head!

If you don't release the pressure of the dosing head, liquid might splash when opening dosing head or removing liquid tube.

- 1 Always release pressure of dosing head by opening the bottle before removing liquid tube.
- 2 Wear protective glasses.

- 1 To release pressure of dosing head, open bottle.
- 2 Open the head with the special bolt driver.
- 3 Take out the micro dispensing valve and clean it, e.g in a ultrasonic bath.
- 4 After the cleaning reinstall the micro dispensing valve.

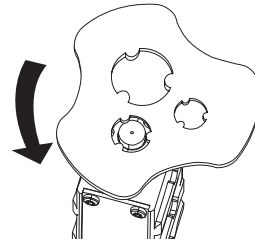

6.3 Disposal

In conformance with the European Directive 2002/96/EC on Waste Electrical and Electronic Equipment (WEEE) this device may not be disposed of in domestic waste. This also applies to countries outside the EU, per their specific requirements.

Please dispose of this product in accordance with local regulations at the collecting point specified for electrical and electronic equipment. If you have any questions, please contact the responsible authority or the distributor from which you purchased this device. Should this device be passed on to other parties (for private or professional use), the content of this regulation must also be related.

Thank you for your contribution to environmental protection.



7 Troubleshooting

See XPE Operating Instructions for a list of possible error messages and remedies.

| Symptom | Countermeasure |
|------------------------------|---|
| Instrument hangs on startup. | <ul style="list-style-type: none">• Switch off the high-voltage power adapter of the AntiStatic Kit.• After successful startup, switch power adapter on again. |
| Lid drips. | <ul style="list-style-type: none">• Change ferrule, see [Installing new ferrule on liquid tube ▶ 23]. |
| Liquid dosing head drips. | <ul style="list-style-type: none">• Check cap.• Make sure there is not too much air in tubing and check air connector module. |
| Liquid dosing does not work. | <ul style="list-style-type: none">• Check filter.• Check, that dosing head is installed correctly. If there is just a small gap between dosing head and its support, press it down slightly again. |

8 Technical Data

Note

Also **see** XPE Operating Instructions for further information.

8.1 General data



CAUTION

Use only with a tested AC Adapter with SELV output current.

Ensure correct polarity 

Power Supply

AC/DC Adapter:

Primary: 100-240 VAC, -15%/+10%, 50/60 Hz, 0.8 A
Secondary: 12 VDC $\pm 5\%$, 2.25 A (with electronic overload protection)

Pump module:

Power supply to pump module: 12 VDC, 2.25 A max. 27 W

Power cable:

Design: 3-core, with country-specific plug

Protection and Standards

- Overvoltage category:
- Degree of pollution:
- Degree of protection:
- Standards for safety and EMC:
- Range of application:

II
2
Protected against dust and water
See Declaration of Conformity
For use only in dry interior rooms

Environmental conditions

- Height above mean sea level:
- Ambient temperature range:
- Relative air humidity:

up to 4000 m
5 to 40 °C
max. 80 % up to 31 °C, linearly decreasing to 50 % at 40 °C, noncondensing

8.2 Explanatory notes for the METTLER TOLEDO AC adapter

The certified external power supply which conforms to the requirements for Class II double insulated equipment is not provided with a protective earth connection but with a functional earth connection for EMC purposes. This earth connection IS NOT a safety feature. Further information about conformance of our products can be found in the brochure "Declaration of Conformity" which is coming with each product.

In case of testing with regard to the European Directive 2001/95/EC the power supply and the instrument have to be handled as Class II double insulated equipment.

Consequently an earth bonding test is not required. Similarly it is not necessary to carry out an earth bonding test between the supply earth conductor and any exposed metalwork on the instrument.

Because the instruments are sensitive to static charges a leakage resistor, typically $10\text{ k}\Omega$, is connected between the earth connector and the power supply output terminals. The arrangement is shown in the equivalent circuit diagram. This resistor is not part of the electrical safety arrangement and does not require testing at regular intervals.

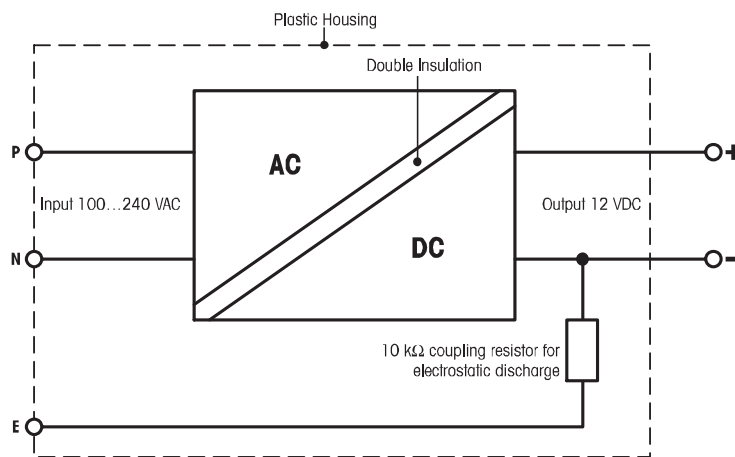

Equivalent circuit diagram

8.3 Model-specific data

Tested solvents:

1,4-dioxane, 1-butanol, acetic acid, acetone, acetonitrile, benzene, chloroform, dichloromethane, ethanol, ethyl acetate, formic acid 98 %, hexane, isopropanol, methanol, pentane, toluene, water (H₂O)

| Dosing Head | | QLL1000 | |
|---|-----------------------|-------------------------------|---------------|
| Dosing properties | | | |
| Limit values | | | |
| Dosing quantity offset (liquid; quantity) | | 20 mg (H ₂ O; 5 g) | |
| Dosing quantity Repeatability (sd) (liquid; quantity) | | 10 mg (H ₂ O; 5 g) | |
| Dosing time (liquid; quantity) | | 35 s (H ₂ O; 5 g) | |
| Typical values | | | |
| Dosing quantity offset (liquid; quantity) | | 1 mg (H ₂ O; 5 g) | |
| Dosing quantity Repeatability (sd) (liquid; quantity) | | 1 mg (H ₂ O; 5 g) | |
| Dosing time (liquid; quantity) | | 30 s (H ₂ O; 5 g) | |
| Tubing | Outer Diameter | Inner Diameter | Length |
| Liquid dosing head > Cap | 3.2 mm | 1.6 mm | 700 mm |
| Inside the bottle | | | 220 mm |
| Pump module > Bottle | 4.0 mm | 2.4 mm | 660 mm |
| Inline Frit Filter | | | |
| Tubing Outer Diameter | | 3.2 mm | |
| Filter pore size | | 10 µm | |

Materials: Wetted parts

| | Bottle | Inline Frit Filter | Liquid bottle cap | Tubing | Body of dosing head | Micro dispensing valve | O-ring |
|------------------------|---------------|---------------------------|--------------------------|---------------|----------------------------|-------------------------------|---------------|
| Borosilicate glass | X | | | | | | |
| PP | | X | X | | | | |
| PE | | | X | | | | |
| FEP | | | | X | | | |
| Stainless steel | | | | | X | X | |
| PEEK | | | | | | X | |
| Sapphire | | | | | | X | |
| Ruby | | | | | | X | |
| FFMK (DuPont™ Kalrez®) | | | | | | | X |

8.4 Dimensions

Pump module with bottle

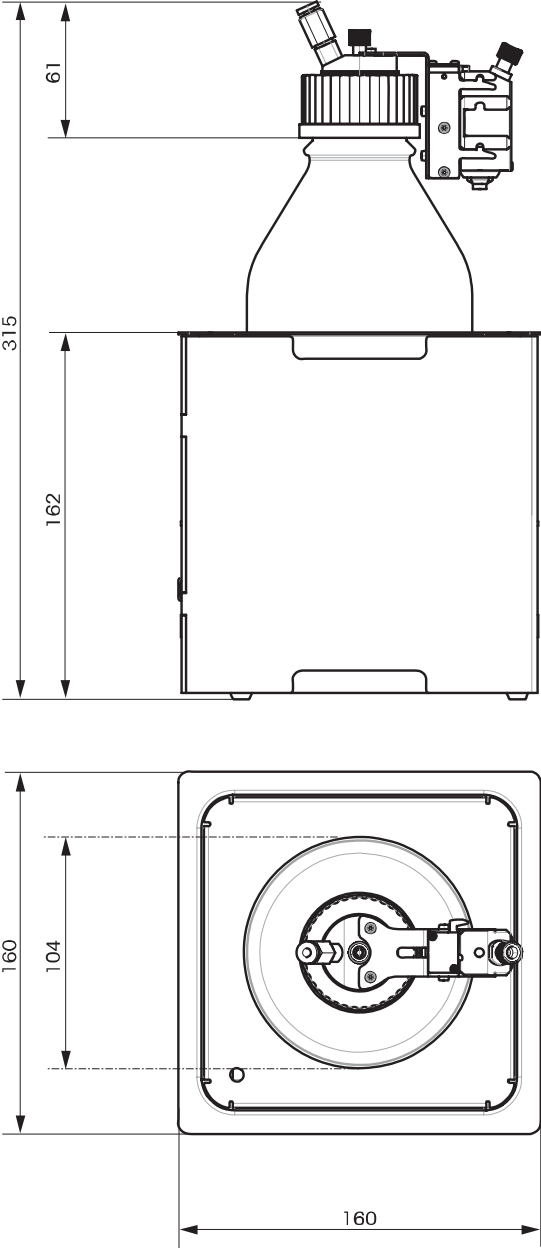

9 Accessories and Spare Parts

Note

Also see XPE Operating Instructions for further information.

9.1 Accessories

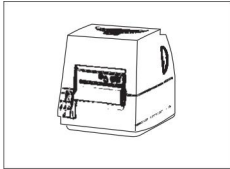
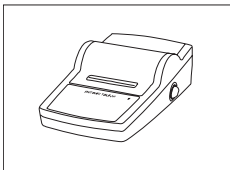
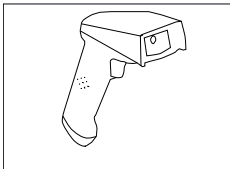
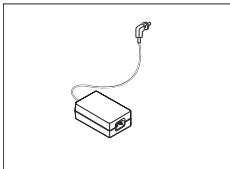
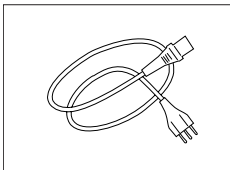
| | Description | Part No. |
|---|--|--|
| Printers | | |
|  | <p>CLS-631 Label printer for Quantos (RS232C/USB-A) Quantos label and ink ribbon kit</p> <ul style="list-style-type: none"> NetCom Kit needed. | <p>11141820 30004309</p> |
|  | <p>RS-P25 printer for Quantos (RS232C) Ink ribbon (set of 2) Standard paper (5 rolls) Self-adhesive paper (3 rolls)</p> <ul style="list-style-type: none"> NetCom Kit needed. | <p>11141834 00065975 00072456 11600388</p> |
| Barcode reader | | |
|  | <p>RS232C Barcode Reader</p> <p>The following accessories are needed for operation (not included):</p> <p>Plus one of the following:</p> | <p>21901297</p> <p>RS232 F cable 21901305 Null modem adapter 21900924 AC adapter 5 V for EU 21901370 AC adapter 5 V for US 21901372 AC adapter 5 V for GB 21901371 AC adapter 5 V for AU 21901370 + 71209966</p> |
| Power supplies | | |
|  | <p>AC/DC adapter (without power cable) 100–240 V AC, 0.8 A, 50/60 Hz, 12 V DC 2.5 A</p> | 11107909 |
|  | <p>Country-specific 3-Pin power cable with grounding conductor.</p> <p>Power cable AU Power cable BR Power cable CH Power cable CN Power cable DK Power cable EU Power cable GB Power cable IL Power cable IN Power cable IT Power cable JP Power cable TH, PE Power cable US Power cable ZA</p> | <p>00088751 30015268 00087920 30047293 00087452 00087925 00089405 00225297 11600569 00087457 11107881 11107880 00088668 00089728</p> |

Optional interfaces

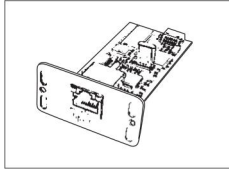

Ethernet Interface for connection to an Ethernet network

11132515

ErgoClips

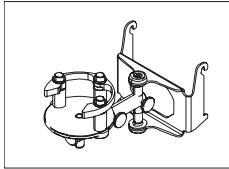

ErgoClip Quantos

11141570

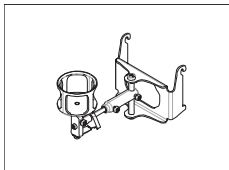

ErgoClip Vial

30260822

Various

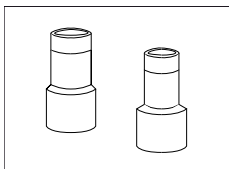

Vial adapters (POM) for magazine set Ø 24 mm

10.3 mm × 25 mm (5 pcs.)

11141571

12 mm × 17 mm (5 pcs.)

11141575

15 mm × 24 mm (5 pcs.)

11141572

16.2 mm × 20 mm (5 pcs.)

11141573

21 mm × 25 mm (5 pcs.)

11141574

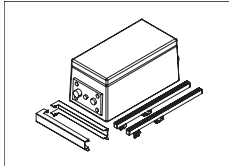

Integrable antistatic kit incl. pair of multiple point-electrode and power supply

11141829



NetCom Kit

11141832

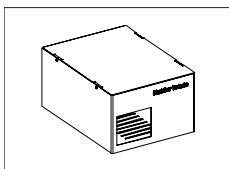

Cable Box

11141845



Grey drip tray

30038741

9.2 Spare parts

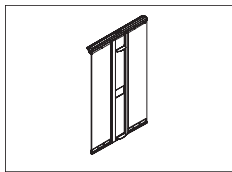
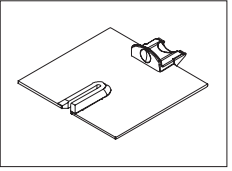
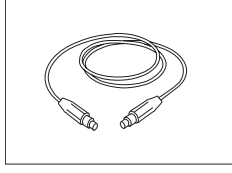
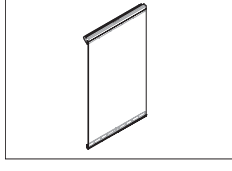
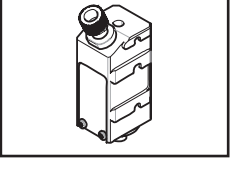
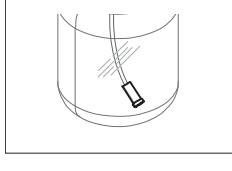
| | Description | Part No. |
|---|--|----------|
|  | MinWeigh door | 11106749 |
|  | Top glass door | 30025650 |
|  | 6-pole CAN cable Length: 60 cm | 30005904 |
|  | Side door conductive | 11106263 |
|  | Liquid dosing head QL001 | 30080473 |
|  | Suction filter PP for 1/8" OD. | 30007832 |
| | Liquid module spare part kit <ul style="list-style-type: none"> • Tubing Teflon® FEP OD 4, ID 2.4 (2m) • Tubing Teflon® FEP OD 3.2, ID 1.6 (3m) • Ferrule, flangeless 1/8" ETFE gb P300X (10 pcs.) • Fitting, flangeless PEEK P347X (5 pcs.) • Pin ISO 2338 4H8 x 20, A1 (5 pcs.) • Tool micro dosing valve • Suction filter PP for 1/8" OD 1 | 30025649 |

Index

A

| | |
|---------------------------|----|
| Aborting dosing | 15 |
| AC Adapter | 27 |
| Accessories | 30 |
| Ambient conditions | 8 |
| Assembling | |
| Dosing head | 10 |
| Liquid module | 9 |
| Pump module | 10 |
| Automatic sample counting | 20 |

C

| | |
|---------------------------|--------|
| Cables | 14 |
| Change liquid | 20 |
| Change RFID data | 18 |
| Changing | |
| Bottle | 19 |
| Ferrule | 23 |
| Liquid | 20 |
| Suction filter | 23 |
| Cleaning | |
| Liquid dosing head | 23 |
| Suction filter | 23 |
| Concentration | 16 |
| Connecting | |
| Liquid module | 14 |
| Tubes | 11 |
| Connectors of pump module | 11, 13 |
| Conventions and symbols | 3 |
| Counting samples | 20 |
| Customizable field | 19 |

D

| | |
|----------------------------|----|
| Data stored in dosing head | 18 |
| Density | 17 |
| Dimension | |
| Pump module | 29 |

| | |
|---------------------------|----|
| Disposal | 24 |
| Dosing | |
| Aborting process | 15 |
| Liquid | 15 |
| Manually | 21 |
| Powder manually | 16 |
| Solution | 16 |
| with pre-prepared solid | 17 |
| Dosing head | |
| Displaying information | 18 |
| Liquid dosing head | 6 |
| Manual dosing head | 6 |
| Preparing new dosing head | 18 |
| Write data | 18 |
| Dosing powder manually | 21 |

E

| | |
|-------------------|----|
| Empty bottle | 20 |
| Explosive liquids | 11 |

F

| | |
|-------------------|----|
| Ferrule | 23 |
| Filling bottle | 20 |
| Flammable liquids | 11 |

G

| | |
|-------------|----|
| Gravimetric | 17 |
|-------------|----|

H

| | |
|------------------|----|
| Head information | 18 |
|------------------|----|

I

| | |
|--------------|----|
| Installation | 8 |
| Installing | |
| Cables | 14 |
| Dosing head | 10 |
| Ferrule | 23 |
| Tubes | 11 |

L

| | |
|--------------------|----|
| Liquid dosing | 15 |
| Liquid dosing head | 6 |
| Cleaning | 23 |
| Technical data | 28 |
| Liquid Kit QLX 45 | 6 |
| Liquid Module | 6 |
| Location | 8 |

| | | | |
|----------------------------|--------|---------------------------|----|
| M | | Symbols and conventions | 3 |
| Manual dosing | 21 | T | |
| Manual dosing head | 6 | Technical data | |
| MinWeigh | 21 | Liquid dosing head | 28 |
| Mounting | | Technical data general | 26 |
| Dosing head | 10 | Toxic liquids | 11 |
| Liquid module | 9 | Tubes | 11 |
| Tubes | 11 | U | |
| N | | Update RFID data | 18 |
| Name of the substance | 18 | V | |
| New liquid | 20 | Var1 | 19 |
| O | | Volumetric | 17 |
| Opening liquid dosing head | 23 | W | |
| Options | 8 | Wetted part | 28 |
| Overview | 6 | Wiring liquid module | 14 |
| P | | Write data on dosing head | 18 |
| PEEK nut | 23 | | |
| Power cable | 13 | | |
| Power supply voltage | 13 | | |
| Prepared samples | 17 | | |
| Preparing new dosing head | 18 | | |
| Pressure release | 17 | | |
| Protective gas | 11 | | |
| Purge | 23 | | |
| Purging liquid dosing head | 23 | | |
| R | | | |
| Rear of pump module | 11, 13 | | |
| Recommended options | 8 | | |
| Release pressure | 17 | | |
| RFID | 7 | | |
| RFID data | 18 | | |
| S | | | |
| Safety precautions | 4 | | |
| Sample counter | 20 | | |
| Scope of delivery | | | |
| Liquid module | 8 | | |
| Selecting the location | 8 | | |
| Settings | | | |
| Liquid module | 15 | | |
| Solution dosing | 16 | | |
| Solvent | 28 | | |
| Spare parts | 32 | | |
| Suction filter | 23 | | |
| Switching Off | 17 | | |

GWP®

Good Weighing Practice™

GWP® is the global weighing standard, ensuring consistent accuracy of weighing processes, applicable to all equipment from any manufacturer. It helps to:

- Choose the appropriate balance or scale
- Calibrate and operate your weighing equipment with security
- Comply with quality and compliance standards in laboratory and manufacturing

▶ www.mt.com/GWP

www.mt.com/quantos

For more information

Mettler-Toledo GmbH

Im Langacher 44
8606 Greifensee, Switzerland
www.mt.com/contact

Subject to technical changes.
© Mettler-Toledo GmbH 02/2016
30259563B en

