

MP54GBT3 (MS-6855C)
Wireless 11g + Bluetooth
Combo MiniPCI Card

User's Guide

FCC Caution

1. The device complies with Part 15 of the FCC rules. Operation is subject to the following two conditions:
 - (1) This device may not cause harmful interference, and
 - (2) This device must accept any interference received, including interference that may cause undesired operation.
2. FCC RF Radiation Exposure Statement: The equipment complies with FCC RF radiation exposure limits set forth for an uncontrolled environment. This equipment should be installed and operated with a minimum distance of 20 centimeters between the radiator and your body.
3. This Transmitter must not be co-located or operating in conjunction with any other antenna or transmitter.
4. Changes or modifications to this unit not expressly approved by the party responsible for compliance could void the user authority to operate the equipment.

FCC Statement

This device is intended only for OEM integrators under the following

- 1) The antenna must be installed such that 20 cm is maintained between antenna and users, and
- 2) The transmitter module may not be co-located with any other transmitter or antenna.

As long as 2 conditions above are met, further transmitter test will not required. However, the OEM integrator is still responsible for testing end-product for any additional compliance requirements required with module installed (for example, digital device emissions, PC peripheral requirements, etc.).

Important Note

In the event that these conditions can not be example certain laptop configurations or co-location with another transmitter), then the FCC authorization is no longer considered valid the FCC ID can not be used on the final product. In these circumstances, OEM integrator will be responsible for re-evaluating the end product (including the transmitter) and obtaining a separate FCC authorization.

End Product Labeling

This transmitter module is authorized only for use in device where antenna may be installed such that 20 cm may be maintained between antenna and users (for example access points, routers, wireless ADSL and similar equipment). The final end product must be labeled in a area with the following: “Contains TX FCC ID: I4L-MS6855C”.

Manual Information for End Users

The end user must not have manual instructions to remove or install device. The user manual for end users must include the following information in a prominent location: “IMPORTANT NOTE: To comply with FCC RF exposure compliance requirements, the antenna used for this transmitter must be installed to provide a separation distance of at least 20 cm from all persons and must not be co-located operating in conjunction with any other antenna or transmitter.” as a result of e-mail transmission.”

Important Safety Precautions

Always read and follow these basic safety precautions carefully when handling any piece of electronic component.

1. Keep this *User's Guide* for future reference.
2. Keep this equipment away from humidity.
3. Lay this equipment on a reliable flat surface before setting it up.
4. The openings on the enclosure are for air convection hence protects the equipment from overheating.
5. All cautions and warnings on the equipment should be noted.
6. Never pour any liquid into the opening that could damage or cause electrical shock.
7. If any of the following situations arises, get the equipment checked by a service personnel:
 - Liquid has penetrated into the equipment
 - The equipment has been exposed to moisture
 - The equipment has not work well or you can not get it work according to User's Manual
 - The equipment has dropped and damaged
 - If the equipment has obvious sign of breakage
8. DO NOT LEAVE THIS EQUIPMENT IN AN ENVIRONMENT UNCONDITIONED, STORAGE TEMPERATURE ABOVE 60°C OR BELOW -20°C, IT MAY DAMAGE THE EQUIPMENT.

1

Introduction

>>> 1.1 MP54GBT3 (MS-6855C) - Wireless 11g + Bluetooth Combo MiniPCI Card

MSI MP54GBT3, the Wireless 11g + Bluetooth Combo miniPCI Card, is a **Type IIIB** card, which can be used to integrate with such systems as notebook, mini-barebone, PDA, portable PC. With MSI MP54GBT3 embedded inside, a system could provide users with the ability and flexibility to connect up to Internet wirelessly via **802.11g** with speed up to 54Mbps, and to link with peripherals wirelessly through **Bluetooth™ v2.0** and advanced **EDR (Enhanced Data Rate)** technology. **Bluetooth™ v2.0** technology increases the data rate of **Bluetooth™ v1.1/1.2** from 1.0Mbps to 2.1Mbps.

MSI MP54GBT3 is taking advantage of leading technologies from Ralink and CSR. It addresses the co-existence issues in PAN (Personal Area Network) and WLAN (Wireless Local Area Network) markets by providing true simultaneous connectivity while deploying IEEE 802.11g and Bluetooth v2.0. Along with this combo solution, a system installed with a single card is able to offer dual mode capability of WiFi and Bluetooth™. It will benefit system vendors in miniaturization of system dimension and BOM cost reduction, as well as also make users happy with the all-in-one functionality.

>>> 1.2 How MP54GBT3 Works

1.2.1 In WLAN Environment

- **Ad-hoc Mode** : An Ad-hoc network is a local area network or other small network, especially one with wireless or temporary plug-in connections, in which some of the network devices are part of the network only for the duration of a communications session. Users in the network can share files, print to a shared printer, and access the Internet with a shared modem. In this kind of network, new devices can be quickly added; however, users can only communicate with other wireless LAN computers that are in this wireless LAN workgroup, and are within range.

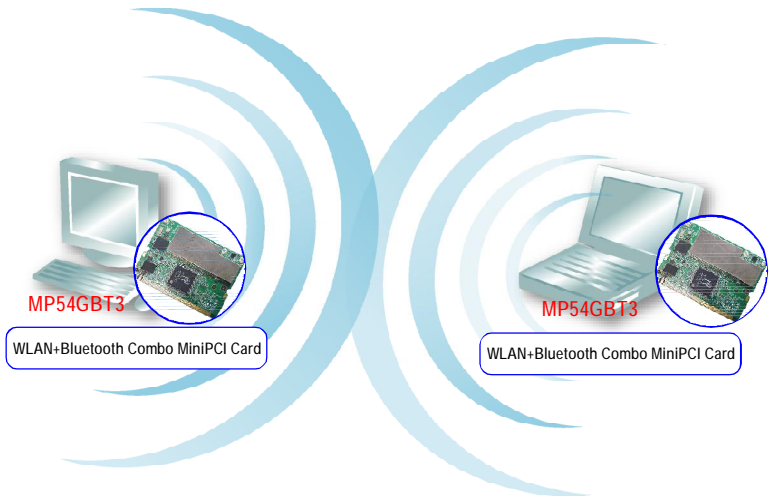

- **Infrastructure Mode :** The difference between Infrastructure network and Ad-hoc network is that the former one includes an Access Point. In an Infrastructure network, the Access Point can manage the bandwidth to maximize bandwidth utilization. Additionally, the Access Point enables users on a wireless LAN to access an existing wired network, allowing wireless users to take advantage of the wired networks resources, such as Internet, email, file transfer, and printer sharing. The scale and range of the Infrastructure networking are larger and wider than that of the Ad-hoc networking.

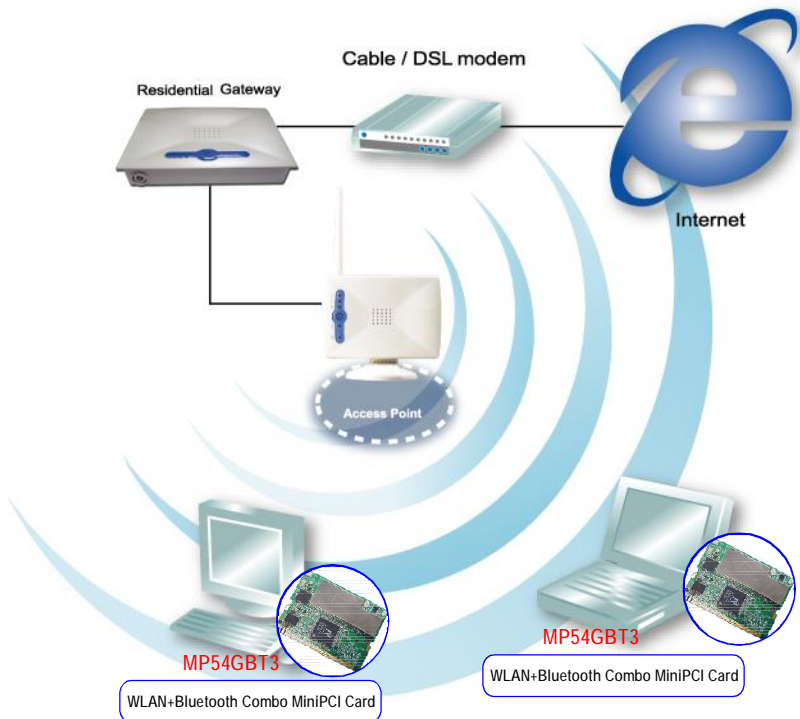

1.2.2 In Bluetooth Connection

The term “Bluetooth” refers to a worldwide standard for the wireless exchange of data between two devices. In order to exchange data, two Bluetooth devices must establish a connection. Before a connection is established, one device must request a connection with another. The second device accepts (or rejects) the connection. The originator of the request is known as the client. The device that accepts (or rejects) the request is known as the server. Many Bluetooth devices can act as both client and server. Every Bluetooth device that provides a service must be prepared to respond to a connection request. Bluetooth software is always running in the background on the server, ready to respond to connection requests.



>>> 1.3 Specifications

Hardware Specification	Form Factor	32-bit Type IIIB
	Operation voltage	3.3V
	Antenna Connector	Two antenna connectors
	Operating System	Microsoft® Windows® 98SE/ME/2000 /XP/XP-64bit
	Environmental	- Operating Temperature: 0 ~ 55°C - Operating Humidity: 10 ~ 90%, non-condensing
	Dimensions (WxDxH)	59.75 x 44.6 x 3.5mm
WLAN Specification	Network Standard	IEEE 802.11; IEEE 802.11b/g
	Frequency Band	2.412-2.484 GHz
	Data Rate	IEEE 802.11g (auto-fallback): - OFDM: 54, 48, 36, 24, 18, 12, 9 and 6Mbps IEEE 802.11b (auto-fallback): - CCK: 11, 5.5 Mbps - DQPSK: 2 Mbps - DBPSK: 1 Mbps
	Media Access Control	CSMA/CA with ACK
	Transmission	DSSS (direct sequential spread spectrum)
	Network Architecture	Ad-Hoc Mode (Peer-to-Peer); Infrastructure Mode
	Antenna Type	Two antenna connectors support
	Power Consumption	TX peak: 310mA RX peak: 250mA Standby mode: 150mA

Channel	<p>IEEE 802.11g: Ch. 1-11 – N. America Ch. 1-13 – Japan Ch. 1-13– Europe ETSI Ch. 10-11 – Spain Ch. 10-13 – France</p> <p>IEEE 802.11b: Ch. 1-11 – N. America Ch. 1-13 – Japan Ch. 1-13– Europe ETSI Ch. 10-11 – Spain Ch. 10-13 – France</p>
Output Power	<p>Output Power(Before Antenna)</p> <p>11b: 17dBm+/-2 Max</p> <p>11g: 14.5dBm+/-1 Max</p>
Receiver Sensitivity (Average Value)	<p>54 Mbps OFDM @ 10% PER = -65 dBm 48 Mbps OFDM @ 10% PER = -66 dBm 36 Mbps OFDM @ 10% PER = -70 dBm 24 Mbps OFDM @ 10% PER = -74 dBm 18 Mbps OFDM @ 10% PER = -77 dBm 12 Mbps OFDM @ 10% PER = -79 dBm 11 Mbps CCK @ 8% PER = -80 dBm 9 Mbps OFDM @ 10% PER = -81 dBm 6 Mbps OFDM @ 10% PER = -82 dBm 5.5 Mbps CCK @ 8% PER = -82 dBm 2 Mbps QPSK @ 8% PER = -83 dBm 1 Mbps BPSK @ 8% PER = -83 dBm</p>

Bluetooth Specification	Network Standard	Bluetooth v2.0 (Class II) +EDR
	Frequency Band	2.4-2.483 GHz
	Data Rate	Up to 2.1Mbps
	Channel	79 sub-channels
	Transmission	FHSS (Frequency Hopping Spread Spectrum)
	Modulation	GFSK
	Antenna Type	One antenna connector support
	Power Consumption	66 mA (maximum, continuous TX)
	Max. Output Power	Up to 2dBm
	Max. Input Level	0dBm
	Receiver Sensitivity	-70dBm @ BER<0.1%
	Range	Up to 10 m
	Physical Links	Support ACL link
	Network Capabilities	Support piconet point-to-point and point-to-multipoint connections
	Link Manager	3-slot Packets: Yes 5-slot Packets: Yes Slot Offset: Yes Timing Accuracy: Yes Switch: Yes Hold Mode: Yes Sniff Mode: Yes Test Mode: Yes Park Mode: Yes RSSI: Yes Power Control: Yes Authentication: Yes Encryption: Yes

>>> 1.4 System Requirements

Before installing MP54GBT3, your PC should meet the following items:



- One desktop/notebook PC with an available MiniPCI slot.
- Windows® 98SE/ME/2000/XP/XP 64bit operating system.
- Minimum 5MB free disk space for installing the driver and utilities.
- One CD-ROM drive, double speed or higher.

>>> 1.5 Package Contents

Unpack the package and check all the items carefully. If any item contained is damaged or missing, please contact your local dealer as soon as possible. Also, keep the box and packing materials in case you need to ship the unit in the future. The package should contain the following items:

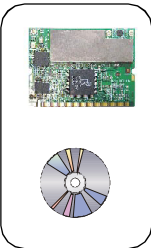

- One Wireless 11g + Bluetooth Combo MiniPCI Card.
- One Installation CD-ROM including drivers, utilities, and the manual files.

>>> 1.6 Product View

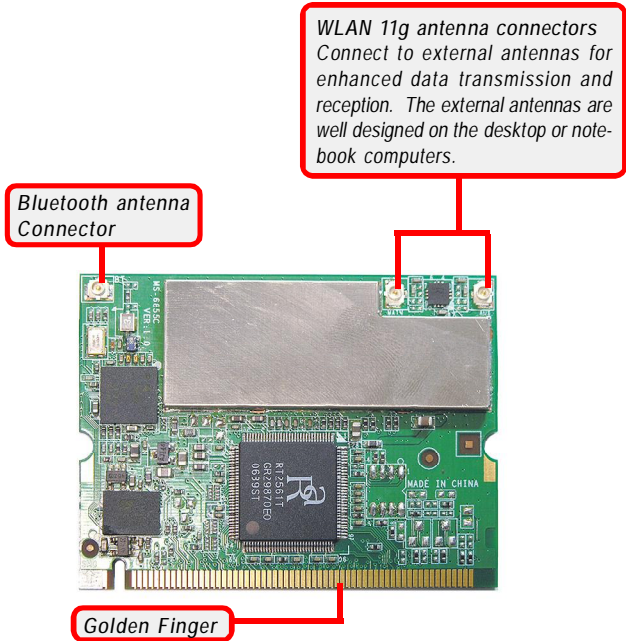

2

Hardware Installation

The following diagrams provide you a basic installation for your MP54GBT3. The instruction below is suitable for most computers with MiniPCI slot. For more information about the MiniPCI module, please refer to your computer's manual.

🔧 Installing MP54GBT3:

1. Locate the MiniPCI slot on the mainboard. Place your MP54GBT3 over the MiniPCI slot (at an angle of 30 degrees). Then, gently insert it into the slot until the golden finger of the card gets fully inserted.
2. Press down the card, and the retaining clips (on two sides of the slot) will lock onto the notches of the card.
3. Connect the antenna's cable to the connector on the card.

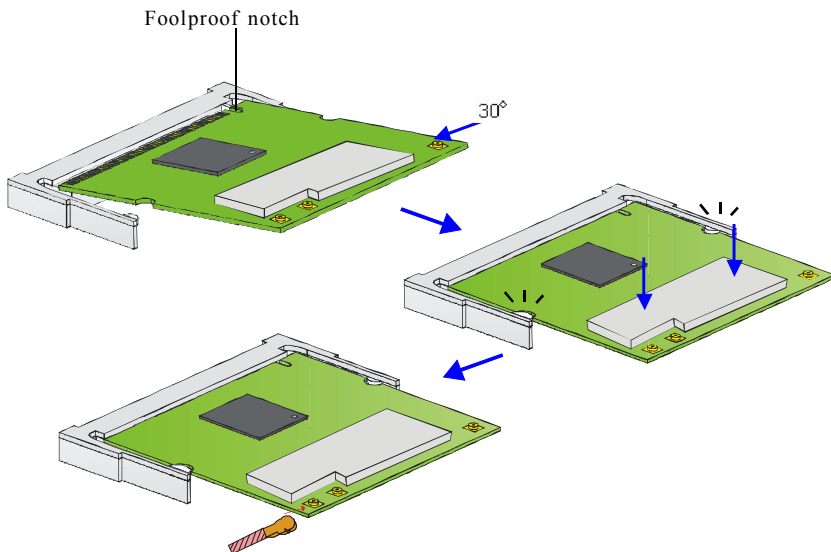

3

Software Installation

This chapter describes the procedures of installing the driver and utility. Follow the instruction step by step to finish the installation. If you use Windows® 98SE/ME, please prepare the Windows® Setup CD at hand before installing the driver; because the system will ask you to insert the Setup CD to copy files during the installation.

Please **NOTE** that the MP54GBT3 should be installed into your computer before installing the driver and utility. Then, the operating system will detect a new device and start to configure the new device. Click *Cancel* here to start installation from the InstallShield Wizard.



Tip: The MP54GBT3 adapter should be installed into your PC before installing the driver and utility.

STEP 1

Insert the software CD into your CD-ROM drive, and the Setup program should launch automatically.

If the Autorun program doesn't launch automatically, click **Start** at the taskbar and select **Run....** Type *E:\setup.exe* (where *E* is your CD-drive) in the Open box and click *OK* to launch the Setup program manually.

The main screen of Setup program will appear as below.

**STEP 2**

1. Click the Install WLAN Driver button.
2. The welcome screen of InstallShield Wizard appears. Click *Next*.
3. Read and accept the License Agreement; then, click *Next*.
4. Click *Install* and the program will copy the necessary files to the system. The progress indicator shows the installing status.
5. Click *Finish* when the WLAN driver installation is completed.

STEP 3

1. Click the Install Bluetooth Driver button.
2. The welcome screen of InstallShield Wizard appears. Click *Next*.
3. Read and accept the License Agreement; then, click *Next*.
4. Click *Next* to install the driver in the default destination folder.
5. Click *Install* and the program will copy the necessary files to the system. The progress indicator shows the installing status.
6. Click *Finish* when the bluetooth driver installation is completed.

STEP 4

Click the Exit button.

The Wireless LAN icon and Bluetooth icon will appear in the status bar.

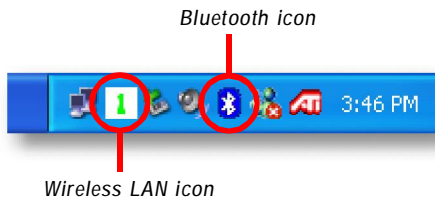

Preface

Chapter 1

General Introductions

Chapter 2

Getting Started

Chapter 3

Customizing this Notebook

Chapter 4

BIOS setup



Regulations Information

FCC-B Radio Frequency Interference Statement

This equipment has been tested and found to comply with the limits for a Class B digital device, pursuant to part 15 of the FCC rules. These limits are designed to provide reasonable protection against harmful interference in a residential installation. This equipment generates uses and can radiate radio frequency energy and, if not installed and used in accordance with the instructions, may cause harmful interference to radio communications. However, there is no guarantee that interference will not occur in a particular installation. If this equipment does cause harmful interference to radio or television reception, which can be determined by turning the equipment off and on, the user is encouraged to try to correct the interference by one or more of the following measures:

- w Reorient or relocate the receiving antenna.
- w Increase the separation between the equipment and receiver.
- w Connect the equipment into an outlet on a circuit different from that to which the receiver is connected.
- w Consult the dealer or an experienced radio TV technician for help.

NOTE

1. *The changes or modifications not expressly approved by the party responsible for compliance could void the user's authority to operate the equipment.*
2. *Shield interface cables and AC power cord, if any must be used in order to comply with the emission limits.*

FCC Conditions

This device complies with part 15 of the FCC Rules. Operation is subject to the following two conditions:

1. This device may not cause harmful interference.
2. This device must accept any interference received, including interference that may cause undesired operation.



廢電池請回收

For better environmental protection, waste batteries should be collected separately for recycling or special disposal.

Safety Guideline for Using Lithium Battery

(Danish) ADVARSEL! Lithiumbatteri --- Eksplosionsfare ved fejlagtig håndtering. Udskiftning må kun ske med batteri af same fabrikat og type. Levé det brugte batteri tilbage til leverandøren.

(Deutsch) VORSICHT: Explosionsgefahr bei unsachgemäßem Austausch der Batterie. Ersatz nur durch denselben oder einen vom Hersteller empfohlenen gleich-wertigen Typ. Entsorgung gebrauchter Batterien nach Angaben des Herstellers.

(English) CAUTION: Danger of explosion if battery is incorrectly replaced. Replace only with the same or equivalent type recommended by the equipment manufacturer. Discard used batteries according to manufacturer's instructions.

(Finnish) VAROITUS: Paristo voi räjähtää, jos se on virheellisesti asennettu. Vaihda paristo ainoastaan valmistajan suosittelemaan tyyppiin. Hävitä käytetty paristo valmistajan ohjeiden mukaisesti.

(French) ATTENTION: Il y a danger d'ex;losion s'il y a remplacement incorrect de la batterie. Remplacer uniquement avec une batterie du meme type ou d'un type équivalent recommandé par le constructeur. Mettre au rebut les batteries usages conformément aux instructions du fabricant.

(Norwegian) ADVARSEL: Eksplosjonsfare ved feilaktig skifte av batteri. Benytt same batteritype eller en tilsvarende type anbefalt av apparatfabrikanten. Brukte batterier kasseres i henhold til fabrikantens instruksjoner.

(Swedish) VARNING: Explosionsfara vid felaktigt batteribyte. Använd samma batterityp eller en ekvivalent typ som rekommenderas av apparatillverkaren. Kassera använt batteri enligt fabrikantens instruction.

Caution on Using Modem

1. Never install telephone wiring during a lightning storm.
2. Never install telephone jacks in wet locations unless the jack is specifically designed for wet locations.
3. Never touch uninsulated telephone wires or terminals unless the telephone line has been disconnected at the network interface.
4. Use caution when installing or modifying telephone lines.
5. Avoid using the telephone function (other than a cordless type) during an electrical storm. There may be a remote risk of electric shock from lightning.
6. Do not use the telephone function to report a gas leak in the vicinity of the leak.

CD-ROM Drive Notice

CAUTION: This appliance contains a laser system and is classified as a "CLASS 1 LASER PRODUCT." To use this model properly, read the instruction manual carefully and keep this manual for your future reference. In case of any trouble with this model, please contact your nearest "AUTHORIZED service station." To prevent direct exposure to the laser beam, do not try to open the enclosure.

Macrovision Notice

This product incorporates copyright protection technology that is protected by U.S. patents and other intellectual property rights. Use of this copyright protection technology must be authorized by Macrovision, and is intended for home and other limited viewing uses only unless otherwise authorized by Macrovision. Reverse engineering or disassembly is prohibited.

Safety Instructions

1. Read the safety instructions carefully and thoroughly.
2. Save this User Guide for possible use later.
3. Keep this equipment away from humidity and high temperature.
4. Lay this equipment on a stable surface before setting it up.
5. The openings on the enclosure are used for air convection and to prevent the equipment from overheating. Do not cover the openings.
6. Make sure that the power voltage is within its safety range and has been adjusted properly to the value of 100~240V before connecting the equipment to the power inlet.
7. Place the power cord in a way that people are unlikely to step on it. Do not place anything on the power cord.
8. Always unplug the power cord before inserting any add-on card or module.
9. All cautions and warnings on the equipment should be noted.
10. If any of the following situations arises, get the equipment checked by a service personnel:

- w The power cord or plug is damaged.
 - w Liquid has penetrated into the equipment.
 - w The equipment has been exposed to moisture.
 - w The equipment has not worked well or you can not get it work according to User's Manual.
 - w The equipment was dropped and damaged.
 - w The equipment has obvious signs of breakage.
11. Never pour any liquid into the opening that could damage the equipment or cause an electrical shock.
 12. Do not leave the equipment in an unconditioned environment with a storage temperature of 35°C (95°F) or above, which may damage the equipment.
 13. To prevent explosion caused by improper battery replacement, use the same or equivalent type of battery recommended by the manufacturer only.



WEEE Statement

(English) Under the European Union ("EU") Directive on Waste Electrical and Electronic Equipment, Directive 2002/96/EC, which takes effect on August 13, 2005, products of "electrical and electronic equipment" cannot be discarded as municipal waste anymore and manufacturers of covered electronic equipment will be obligated to take back such products at the end of their useful life.

(Deutsch) Gemäß der Richtlinie 2002/96/EG über Elektro- und Elektronik-Altgeräte dürfen Elektro- und Elektronik-Altgeräte nicht mehr als kommunale Abfälle entsorgt werden, die sich auf 13. August, 2005 wirken. Und der Hersteller von bedeckt Elektronik-Altgeräte gesetzlich zur gebrachten Produkte am Ende seines Baruchbarkeitsdauer zurückzunehmen.

(Français) Au sujet de la directive européenne (EU) relative aux déchets des équipement électriques et électroniques, directive 2002/96/EC, prenant effet le 13 août 2005, que les produits électriques et électroniques ne peuvent être déposés dans les décharges ou tout simplement mis à la poubelle. Les fabricants de ces équipements seront obligés de récupérer certains produits en fin de vie.

(Русский) В соответствии с директивой Европейского Союза (ЕС) по предотвращению загрязнения окружающей среды использованным электрическим и электронным оборудованием (директива WEEE 2002/96/EC), вступающей в силу 13 августа 2005 года, изделия, относящиеся к электрическому и электронному оборудованию, не могут

рассматриваться как бытовой мусор, поэтому производители вышеперечисленного электронного оборудования обязаны принимать его для переработки по окончании срока службы.

(Español) Bajo la directiva 2002/96/EC de la Unión Europea en materia de desechos y/o equipos electrónicos, con fecha de rigor desde el 13 de agosto de 2005, los productos clasificados como "eléctricos y equipos electrónicos" no pueden ser depositados en los contenedores habituales de su municipio, los fabricantes de equipos electrónicos, están obligados a hacerse cargo de dichos productos al termino de su período de vida.

(Nederlands) De richtlijn van de Europese Unie (EU) met betrekking tot Vervuiling van Elektrische en Electronische producten (2002/96/EC), die op 13 Augustus 2005 in zal gaan kunnen niet meer beschouwd worden als vervuiling. Fabrikanten van dit soort producten worden verplicht om producten retour te nemen aan het eind van hun levenscyclus..

(Srpski) Po Direktivi Evropske unije ("EU") o odbačenju elektonskoj i električnoj opremi, Direktiva 2002/96/EC, koja stupa na snagu od 13. Avgusta 2005, proizvodi koji spadaju pod "elektronsku i električnu opremu" ne mogu više biti odbačeni kao običan otpad i proizvođači ove opreme biće prinuđeni da uzmu natrag ove proizvode na kraju njihovog uobičajenog veka trajanja.

(Polski) Zgodnie z Dyrektywą Unii Europejskiej ("UE") dotyczącą odpadów produktów elektrycznych i elektronicznych (Dyrektywa 2002/96/EC), która wchodzi w życie 13 sierpnia 2005, tzw. "produkty oraz wyposażenie elektryczne i elektroniczne " nie mogą być traktowane jako śmieci komunalne, tak więc producenci tych produktów będą zobowiązani do odbierania ich w

momencie gdy produkt jest wycofywany z użycia.

(TÜRKÇE) Avrupa Birliği (AB) Kararnamesi Elektrik ve Elektronik Malzeme Atığı, 2002/96/EC Kararnamesi altında 13 Ağustos 2005 tarihinden itibaren geçerli olmak üzere, elektrikli ve elektronik malzemeler diğer atıklar gibi çöpe atılamayacak ve bu elektronik cihazların üreticileri, cihazların kullanım süreleri bittikten sonra ürünleri geri toplamakla yükümlü olacaktır.

(ČESKY) Podle směrnice Evropské unie ("EU") o likvidaci elektrických a elektronických výrobků 2002/96/EC platné od 13. srpna 2005 je zakázáno likvidovat "elektrické a elektronické výrobky" v běžném komunálním odpadu a výrobci elektronických výrobků, na které se tato směrnice vztahuje, budou povinni odebírat takové výrobky zpět po skončení jejich životnosti.

(MAGYAR) Az Európai Unió („EU”) 2005. augusztus 13-án hatályba lépő, az elektromos és elektronikus berendezések hulladékairól szóló 2002/96/EK irányelve szerint az elektromos és elektronikus berendezések többé nem kezelhetők lakossági hulladékként, és az ilyen elektronikus berendezések gyártói kötelessé válnak az ilyen termékek visszavételére azok hasznos élettartama végén.

(Italiano) In base alla Direttiva dell'Unione Europea (EU) sullo Smaltimento dei Materiali Elettrici ed Elettronici, Direttiva 2002/96/EC in vigore dal 13 Agosto 2005, prodotti appartenenti alla categoria dei Materiali Elettrici ed Elettronici non possono più essere eliminati come rifiuti municipali: i produttori di detti materiali saranno obbligati a ritirare ogni prodotto alla fine del suo ciclo di vita..

Trademarks

All trademarks are the properties of their respective owners.

- w Microsoft is a registered trademark of Microsoft Corporation.
Windows®98/ME, 2000/XP are registered trademarks of Microsoft Corporation.
- w AMI® is a registered trademark of American Megatrends Inc.
- w PCMCIA and CardBus are registered trademarks of the Personal Notebook Memory Card International Association.

Release History

Version	Revision Note	Date
1.0	First Release	03, 2006

Table of Content

Preface

Regulations Information	II
FCC-B Radio Frequency Interference Statement	II
FCC Conditions	III
Safety Guideline for Using Lithium Battery	IV
Caution on Using Modem	V
CD-ROM Drive Notice	V
Macrovision Notice	VI
Safety Instructions	VI
WEEE Statement	VIII
Trademarks	XI
Release History	XI

Introductions

How to Use This Manual	1-2
Unpacking	1-4

Getting Started

Specification	2-2
Product Overview	2-5

Top-open View	2-5
Front View	2-7
Left-side View	2-10
Right-side View	2-12
Rear View	2-14
Bottom View	2-15
Power Management	2-17
AC Adapter	2-17
Battery Pack	2-18
Using the Battery Pack	2-21
Basic Operations	2-23
Safety and Comfort Tips	2-23
Have a Good Work Habit	2-24
Knowing the Keyboard	2-25
Knowing the Touchpad	2-31
About Hard Disk Drive	2-35
Using the Optical Device Drive	2-36
 Customizing this Notebook	
<hr/>	
Connecting the External Devices	3-2
Connecting the Peripheral Devices	3-3
Connecting the Communication Devices	3-6
PC Card Installation	3-7
Installing the PC card	3-7

Removing the PC card	3-8
Express Card Installation (Optional)	3-9
Installing the Express card	3-9
Removing the Express card	3-9
Safely Remove Hardware.....	3-10

BIOS Setup

About BIOS Setup.....	4-2
When to Use BIOS Setup	4-2
How to Run BIOS Setup.....	4-2
Control Keys	4-3
BIOS Setup Menu.....	4-4
Main menu	4-5
Advanced menu.....	4-7
Security menu.....	4-9
Boot menu.....	4-11
Exit menu.....	4-12

Preface

Chapter 1

General Introductions

Chapter 2

Getting Started

Chapter 3

Customizing this Notebook

Chapter 4

BIOS setup



Congratulations on becoming a new user of this notebook, the finely designed notebook. This brand-new exquisite notebook will give you a delightful and professional experience in using notebook. We are proud to tell our users that this notebook is thoroughly tested and certified by our reputation for unsurpassed dependability and customer satisfaction.

How to Use This Manual

This User's Manual provides instructions and illustrations on how to operate this notebook. It is recommended to read this manual carefully before using this notebook.

Chapter 1, General Introductions, includes the descriptions of all the accessories of this notebook. It is recommended to check out that if you have all the accessories included when you open the packing box. If any item is damaged or missing, please contact the vendor where you purchased this notebook.

Chapter 2, Getting Started, provides the specification of this notebook, and introduces the function buttons, quick launch buttons, connectors, LEDs and externals of this notebook. Also, this chapter instructs the correct procedure of installing or uninstalling the battery pack, and the brief ideas on how to use this notebook.

Chapter 3, Customizing this Notebook, gives instructions not only in connecting the mouse, keyboard, webcam, printer, external monitor, IEEE 1394 devices, and communication devices, but also in installing and removing the PC card.

Chapter 4, BIOS setup, provides information on BIOS Setup program and allows you to configure the system for optimum use.

Unpacking

First, unpack the shipping carton and check all items carefully. If any item contained is damaged or missing, please contact your local dealer immediately. Also, keep the box and packing materials in case you need to ship the unit in the future.

The package should contain the following items:

- w Notebook PC
- w User's Manual or Quick Start Guide
- w All-in-one application disk, containing the drivers, utilities, and optional recovery function.
- w High-capacity Li-ion battery pack
- w AC adapter and power cord
- w Phone cable/Phone jack (optional)
- w Notebook carry bag (optional)

These accessories listed above may change without notice.

Preface

Chapter 1

General Introductions

Chapter 2

Getting Started

Chapter 3

Customizing this Notebook

Chapter 4

BIOS setup



Specification

Physical Characteristic	
Dimension	332mm(L) x 229.5mm(D) x 32.4mm(H)
Weight	1.9 kg (3-cell Li-battery included)
CPU	
Support Processor	Intel® Core™ Duo Processor Intel® Core™ 2 Duo Processor
Core Chips	
North Bridge	ATI RC410ME
South Bridge	ATI SB450
Memory	
Technology	DDR2 533/667
Memory	DDR II SO-DIMM X 2 slots 256MB/512MB/1GB DDR II SDRAM
Maximum	2GB (1G DDR II SO-DIMM X 2)
Power	
AC Adapter	65W, 19 Volt
Battery Type I	3 cells (Li-Ion)(2400mAh) (Optional) 6 cells (Li-Ion)(4400mAh) (Optional) 9 cells (Li-Ion)(7200mAh) (Optional)
Storage	
HDD form factor	2.5" 9.5mm(High), 40/60/80/100/120GB
Optical Device	DVD Combo / DVD dual / Super Multi / Lightscribe

		(Devices listed here may vary without notice)
I/O Port		
Monitor(VGA)	15 pin Mini D-Sub x 1	
USB	x 3 (USB version 2.0)	
Headphone Out (SPDIF Out supported)	x 1	Support Analog 5.1 function See Product Overview for more information.
Mic-in	x 1	
Line-in	x 1	
TV-Out	S-Video x 1	
RJ11	x 1	
RJ45	x 1	
IEEE1394	x 1	
Card Reader	x 1 (MMC/SD/MS/MS Pro)	
Communication Port		
56K Fax/MODEM MDC (Azaliza)	56k SW/Modem, V90/92 supported	
LAN	Ethernet 10/100M	
Wireless LAN	MS-6855B (Optional) MS-6833B (Optional)	
Bluetooth	MS-6855B (Optional)	
PCMCIA (Optional)		
Slot	Type II x 1	
CardBus	Support	
Express Card (Optional)		

Slot	Express Card Slot x 1
Display	
LCD Type	14" / 14.1" WXGA
Brightness	Brightness controlled by K/B hot-keys
Video	
Controller	RC 410 ME (Ati Radeon® XPRESS 200M)
VRAM	Share System Memory
LCD	1280 x 768 WXGA (Glare or Anti-glare)
CRT Support	640x480, max. 32bit color 800x600, max. 32bit color 1024x768, max. 32bit color 1400x1050, max. 32bit color 1152 x 768, max 32bit color
Audio	
Sound Controller	Embedded in South Bridge
HD Audio Codec	ALC883 (Azaliza Interface)
Internal Speaker	2 Speakers with housing, 1.5W x 2
SoundBlaster	SoundBlaster compatible (Not support DOS)
BIOS	
BIOS	Fast Boot Support --- Yes
Others	
Kensington Lock Hole	x 1

Product Overview

This section provides you the description of basic aspects of your Notebook. It will help you to know more about the appearance of this Notebook before using it.

Top-open View

Press the Cover Latch to open the top cover (LCD Panel). The figure of top-open view and description showing below will lead you to browse the main operating area of your NOTEBOOK.

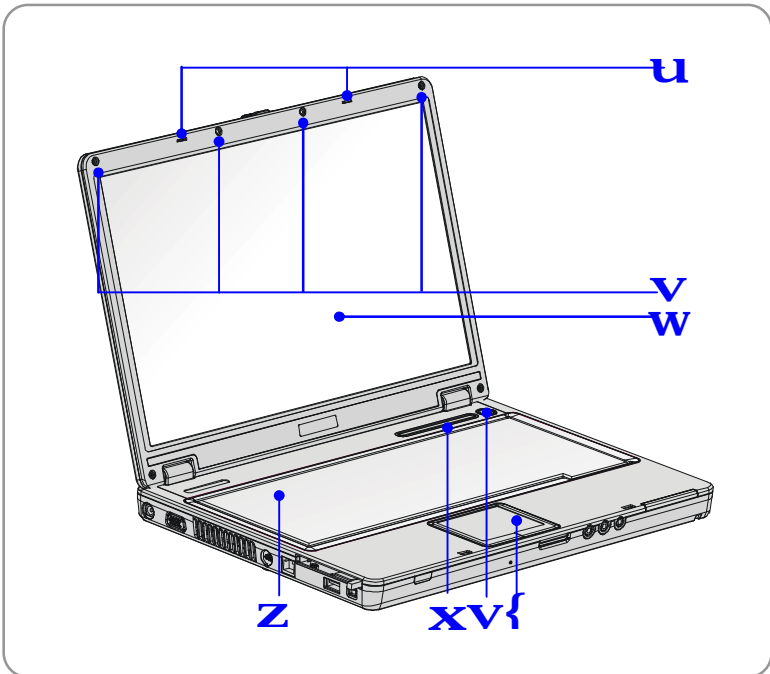

1. Cover Latch (Internal View)

It is a bounce-back device to lock the cover with the deck when closing your Notebook.

2. Rubber Pads

Protect your Notebook from random closing.

3. Display Panel

The 14-inch WXGA color LCD screen displays the output of the computer.

4. Quick Launch Button

	<p>Quick Launch Buttons:</p> <ul style="list-style-type: none">w Simply click the quick launch buttons to speed up the starting of the programs in common use. It helps you to do works more efficiently.w From the top to the bottom, the quick launch buttons are E-mail, Internet, WLAN & BT, and P1 as Search Key or Camera function (optional).
---	--

5. Power Button

Turn Notebook power ON and OFF.

6. Keyboard

The built-in keyboard provides all the functions of a full-sized (US-defined) keyboard.

7. Touchpad

It is the pointing device of the Notebook.

Front View

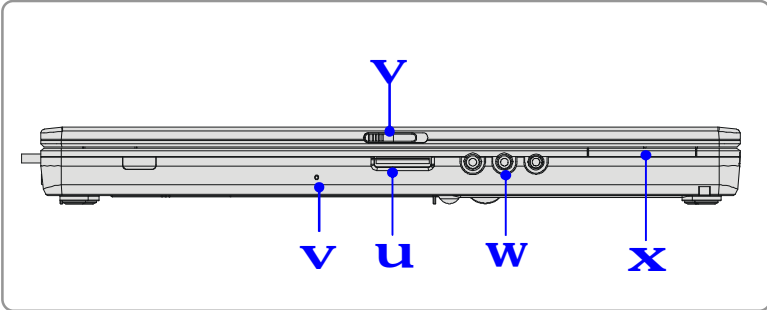

1. 4 in 1 Card Reader





The built-in card reader supports MMC (multi-media card), SD (secure digital), MS (memory stick), and MS Pro cards.

2. Cover Latch (External View)

Press Cover Latch rightward and lift the cover. The Cover Latch will bounce back when loosing it.

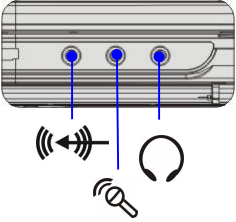



3. Audio Port Connectors

Make high quality sound blaster with stereo system and Hi-Fi function supported. These connectors support Analog 5.1 function. Connect your speakers to the proper connectors as shown below.

	
	<p>Headphones: Used for speakers or headphones.</p> <p>Connect the Front Right and Left speakers here.</p>
	<p>Line In: Used for an external audio device.</p> <p>Connect the Surround Right and Left speakers here.</p>
	<p>Microphone: Used for an external microphone.</p> <p>Connect the Center and Subwoofer speakers here</p>

4. Status LED

	<p>Battery Status</p> <ul style="list-style-type: none"> w Glowing green when the battery is being charged. w Glowing orange when the battery is in low battery status. w Blinking orange if the battery fails and it is recommended to replace a new battery.
---	--

	<ul style="list-style-type: none"> w Battery LED goes out when recharging is done or when the AC adapter is disconnected.
	<p>Wireless LAN and Bluetooth</p> <ul style="list-style-type: none"> w Glowing green when wireless LAN function is enabled. w Glowing blue when Bluetooth function of is enabled. w Glowing green and blue at the same time when Wireless LAN and Bluetooth function are both enabled.
	<p>Power On / OFF / Standby</p> <ul style="list-style-type: none"> w Blinking blue when the system is in suspend mode. w Glowing blue when the system is activated. w LED goes out when the system is turned off.
	<p>Hard Disk In-use: Blinking blue when the notebook is accessing the hard disk drive.</p>
	<p>Caps Lock: Glowing blue when the Caps Lock function is activated.</p>
	<p>Num Lock: Glowing blue when the Num Lock function is activated.</p>

5. Internal Microphone

There is built-in microphone and its function is the same with microphone.

Left-side View

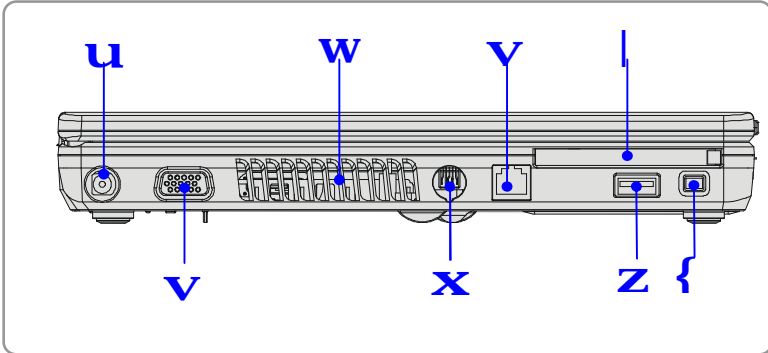

1. Power Connector

To connect the AC adapter and supply power for the Notebook.

2. VGA D-Sub Port

The 15-pin-D-sub VGA port allows you to connect an external monitor or other standard VGA-compatible device (such as a projector) for a great view of the Notebook display.

3. Ventilator

The ventilator is designed to cool the system. DO NOT block the ventilator for air circulation.

4. S-Video Connector

By using a Super VHS (S-Video) cable, this connector allows you to connect a television (NTSC/PAL system) to use as a computer display.

5. RJ-45 Connector

The 100/10 Ethernet connector is used to connect a LAN cable for network connection.

6. USB Port

The USB 2.0 port allows you to connect USB-interface peripheral devices, such as the mouse, keyboard, modem, portable hard disk module, printer and more. The USB-standard interface supports “plug-and-play” technology, so that you can connect and remove the USB devices without turning off the computer.

7. IEEE 1394

The IEEE 1394 port is a high-speed bus that allows you to connect high-end digital devices such as the DV (digital video camera).

8. PC Card Slot (Optional)

The computer provides a PC card slot to support one Type-II PC card for expansion functions, such as LAN/WLAN card, modem card, memory card, etc.

Right-side View

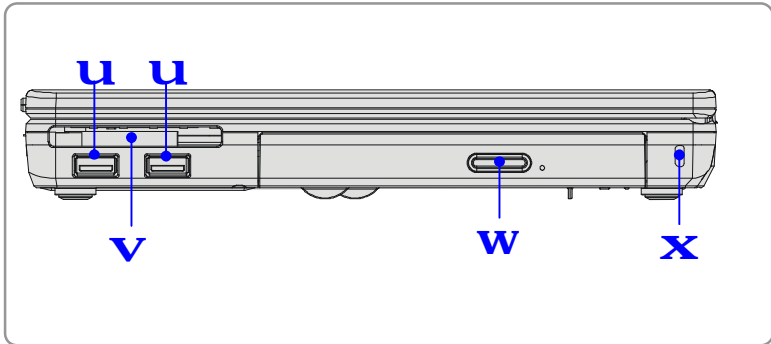

1. USB Ports

The USB 2.0 port allows you to connect USB-interface peripheral devices, such as the mouse, keyboard, modem, portable hard disk module, printer and more. The USB-standard interface supports “plug-and-play” technology, so that you can connect and remove the USB devices without turning off the computer.

2. Express Card Slot (Optional)

The computer provides an Express PC card slot. The new Express Card interface is smaller and faster than PC Card interface. The Express Card technology takes advantage of the scalable, high-bandwidth serial PCI Express and USB2.0 interfaces.

3. **Optical Storage Device**

A slim DVD Combo or DVD Dual or Super Multi (DVD Dual and DVD RAM) or Lightscribe drive is available in the computer, depending on the model you purchased. The optical device allows you to use the CD/DVD disc for installing software, accessing data and playing music/movie on the computer. Lightscribe function allows users to have brief texts curved on the disks.

4. **Kensington Lock Hole**

This is used to lock the Notebook to location for security

Rear View

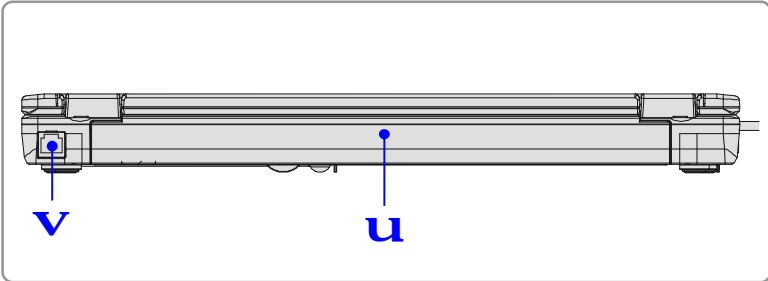

1. Battery Pack (Rear View)

To supply power to your Notebook when the AC adapter is not connected

2. RJ-11 Connector

The computer provides a built-in modem that allows you to connect an FJ-11 telephone line through this connector. With the 56K V.90 modem, you can make a dial-up connection.

Bottom View

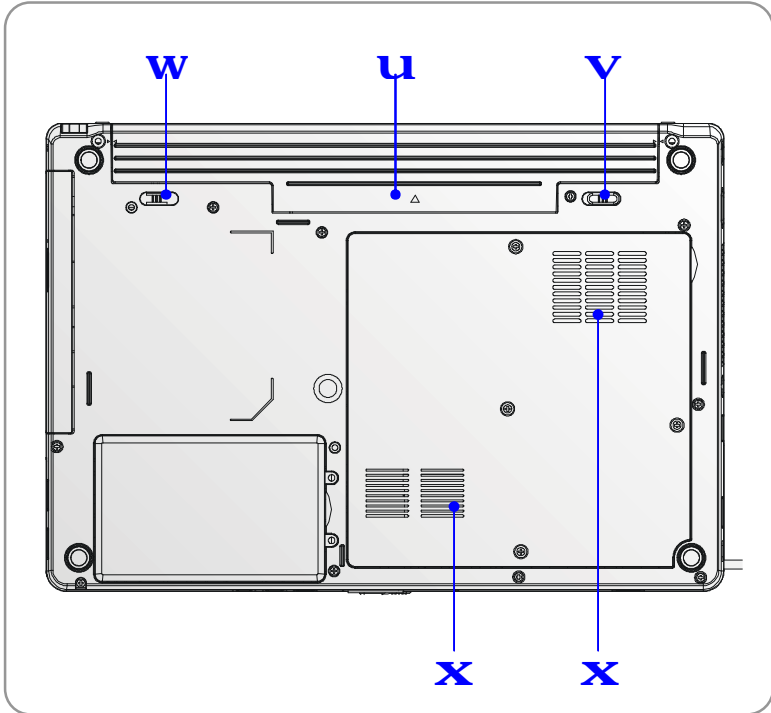

1. Battery Pack

Supply power to your computer when the AC adapter is not connected.

2. Battery Release Button

It is a bounce-back device as a preparation for releasing the battery pack. Press it with one hand and pull the battery pack carefully with the other.

3. **Battery Lock/Unlock Button**

Battery cannot be moved when the button is positioned on lock status.

Once the button is pushed to unlock position, the battery is removable.

4. **Ventilator**

The ventilator is designed to cool the system. DO NOT block the ventilator for air circulation.

Power Management

AC Adapter

Please be noted that it is strongly recommended to connect the AC adapter and use the AC power while using this Notebook for the first time. When the AC adapter is connected, the battery is being charged immediately.

NOTE that the AC adapter included in the package is approved for your Notebook; using other adapter model may damage the Notebook or other devices on the Notebook.

Connecting the AC Power

1. Unpack the package to find the AC adapter and power cord.
2. Attach the power cord to the connector of the AC adapter.
3. Plug the DC end of the adapter to the Notebook, and the male end of the power cord to the electrical outlet.

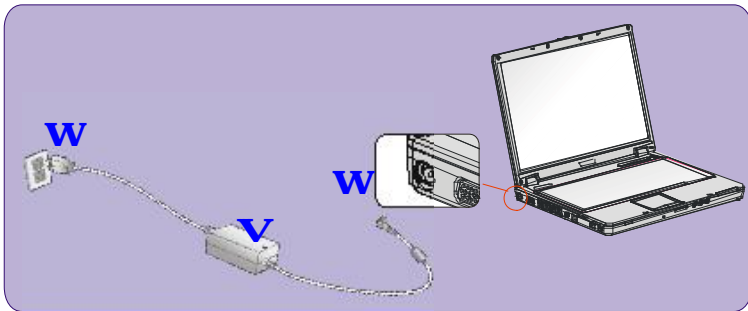

Disconnecting the AC Power

When you disconnect the AC adapter, you should:

1. Unplug the power cord from the electrical outlet first.
2. Unplug the connector from the Notebook.
3. Disconnect the power cord and the connector of AC adapter.
4. When unplugging the power cord, always hold the connector part of the cord. Never pull the cord directly!

Battery Pack

This Notebook is equipped with a high-capacity 6-cell Li-ion Battery pack. The rechargeable Li-ion battery pack is an internal power source of the Notebook.

Releasing the Battery Pack

It's a better way to have extra battery for enough power supply, so you don't have to worry about the lack of battery power. It's recommend to buy a battery pack from your local dealer.

To remove the battery pack:

1. Make sure the Notebook is turned off.
2. Check the Lock/Unlock button is in unlocked status.
3. Locate the Battery Release Button on the bottom side.
4. Push the Release Button to the direction of arrow showing below the button.
5. Slide the left side of the battery pack first out of the compartment and then pull the right side of the battery pack.

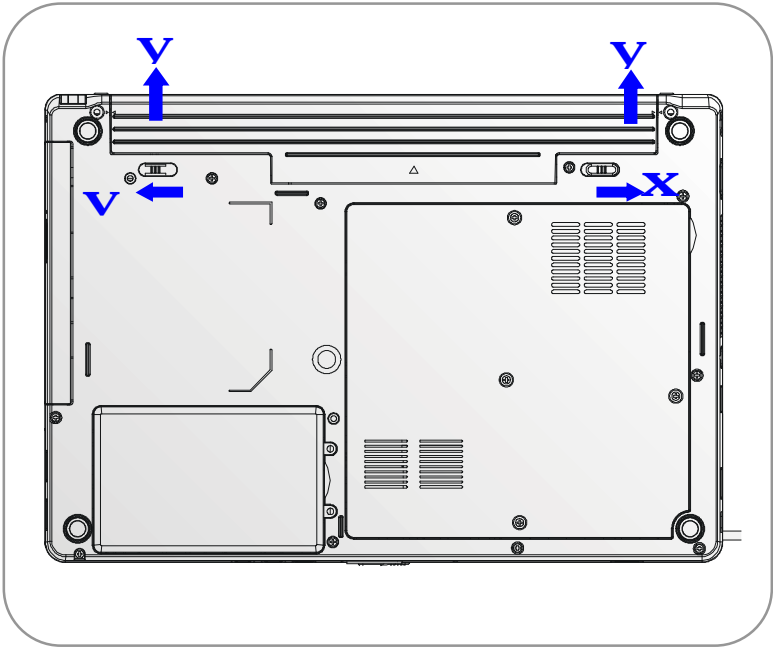

Replacing the Battery Pack

1. Insert the right side of battery pack into the compartment.
2. Slightly slide and press the battery pack into the right place.
3. After the right side of the battery pack fitting the right track, then slightly press the left side of battery pack into the battery chamber.
4. Make sure the Lock/Unlock Button is in lock position.

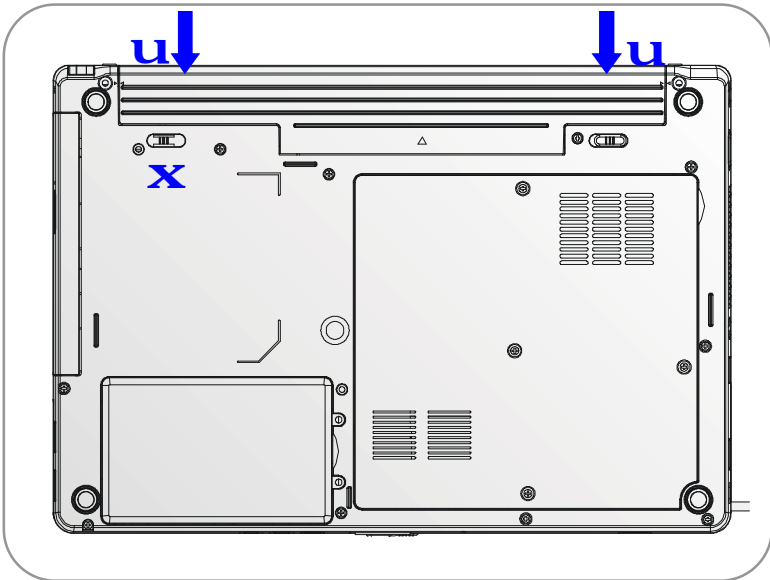

Using the Battery Pack

Battery Safety Tips

Replacing or handling the battery incorrectly may present a risk of fire or explosion, which could cause serious injury.

- w Only replace the main battery pack with the same or equivalent type of battery.
- w Do not disassemble, short-circuit or incinerate batteries or expose them to temperatures above +60° C (+140° F).
- w Do not temper with batteries. Keep them away from children.
- w Do not use rusty or damaged batteries.
- w Dispose of batteries according to local regulations. Check with your local solid waste officials for details about recycling options or for proper disposal in your area.

Conserving Battery Power

Efficient battery power is critical to maintain a normal operation. If the battery power is not managed well, the saved data and customized settings may be lost.

Follow these tips to help optimizing battery life and avoid a sudden power loss.

- w Suspend system operation if the system will be idle for a while or shorten the Suspend Timer's time period.
- w Turn off the system if you won't be using it for a period of time.
- w Disable unneeded settings or remove idle peripherals to conserve power.
- w Connect an AC adapter to the system whenever possible.

Charging the Battery Pack

The battery pack can be recharged while it is installed in the Notebook. Please pay attention to the following tips before recharging the battery:

- w If a charged battery pack is not available, save your work and close all running programs and shut down the system or Save-to-Disk.
- w Plug in an external AC/DC power source.
- w You can use the system, suspend system operation or shut down and turn off the system without interrupting the charging process.
- w The battery pack uses Lithium-ion battery cells that have no “memory effect.” You do not need to discharge the battery pack before you begin charging. However, to optimize the life of battery, we suggest that consuming the battery power completely once a month is necessary.
- w If you do not use the Notebook for a long time, it is suggested to remove the battery pack from your Notebook. This may be helpful to extend your battery life.
- w The actual charging time will be determined by the applications in use.



Caution

1. Do not try to disassemble THE BATTERY PACK.
2. Please follow your local laws and regulations to recycle the unused battery pack.

Basic Operations

If you are a beginner to the Notebook, please read the following tips to make yourself safe and comfortable during the operations.

Safety and Comfort Tips

The Notebook is a portable platform that allows you to work anywhere. However, choosing a good workspace is important if you have to work with your Notebook for long periods of time.

- w Your work area should have enough illumination.
- w Choose the proper desk and chair and adjust their height to fit your posture when operating.
- w When sitting on the chair and adjust the chair's back (if available) to support your back comfortably.
- w Place you feet flat and naturally on the floor, so that your knees and elbows have the proper position (about 90-degree) when operating.
- w Put your hands on the desk naturally to support your wrists.
- w Adjust the angle/position of the LCD panel, so that you can have the optimal view.
- w Avoid using your Notebook in the space where may cause your discomfort (such as on the bed).
- w The Notebook is an electrical device, please treat it with great care to avoid personal injury.

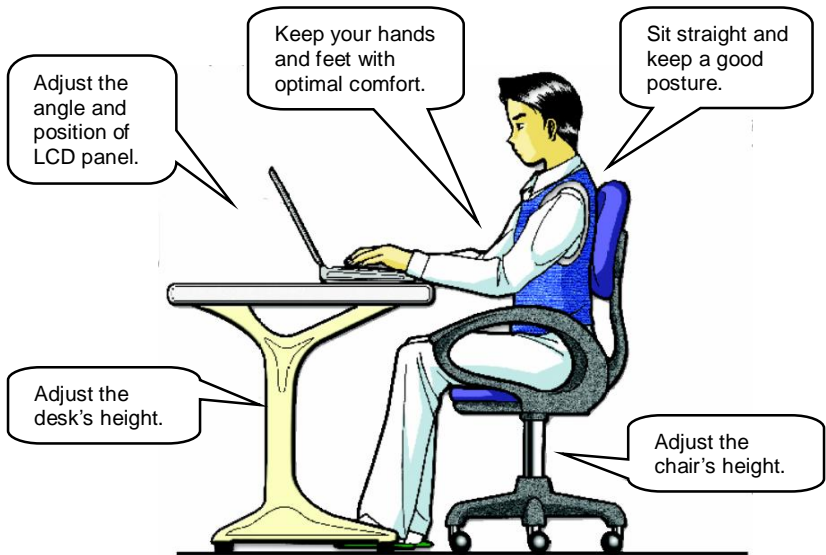

Have a Good Work Habit

Have a good work habit is important if you have to work with your Notebook for long periods of time; otherwise, it may cause discomfort or injury to you. Please keep the following tips in mind when operating.

- w Change your posture frequently.
- w Stretch and exercise you body regularly.
- w Remember to take breaks after working for a period of time.

Typewriter Keys

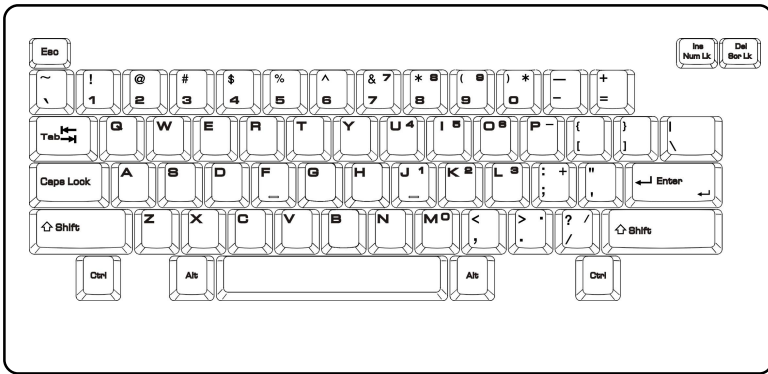

The function of these Typewriter keys is the major function of the keyboard, which is similar to the keys on a typewriter. It also provides several keys for special purposes, such as the [Ctrl], [Alt] and [Esc] key.





When the lock keys are pressed, the corresponding LEDs will light up to indicate their status:



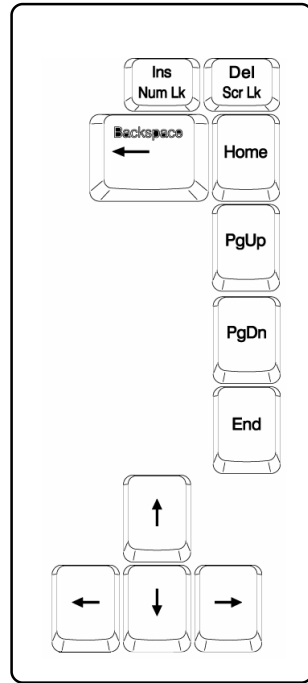

- n **Num Lock:** Press and hold the [Fn] key and press this key to toggle the Num Lock on and off. When this function is activated, you can use the numeric keys that are embedded in the typewriter keys.
- n **Caps Lock:** Press this key to toggle the Caps Lock on and off. When this function is activated, the letters you type are kept in uppercase.
- n **Scroll Lock:** Press and hold the [Fn] key and press this key to toggle the Scroll Lock on and off. This function is defined by individual programs, and it is usually used under DOS.

Cursor Keys



The keyboard provides four cursor (arrow) keys and **[Home]**, **[PgUp]**, **[PgDn]**, **[End]** keys at the lower right corner, which are used to control the cursor movement.



	Move the cursor left for one space.
	Move the cursor right for one space.
	Move the cursor up for one line.
	Move the cursor down for one line.

	Move to the previous page.
	Move to the next page.
	Move to the beginning of the line (or document).
	Move to the end of the line (or document).

The Backspace key, **[Ins]** and **[Del]** keys at upper right corner are use for editing purpose.

	This key is used to switch the typing mode between “insert” and “overtyping” modes.
	Press this key to delete one character to the right of the cursor and move the following text left for one space.
	Press this key to delete one character to the left of the cursor and move the following text left for one space.

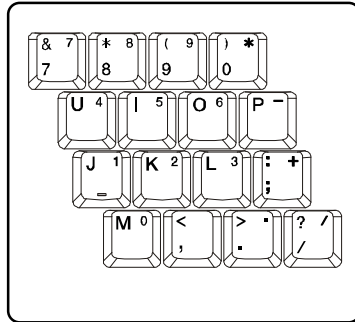

Numeric Keys

The keyboard provides a set of numeric keypad, which is embedded in the typewriter keys. When the Num Lock is activated, you can use these numeric keys to enter numbers and calculations.



















Function Keys

n Windows Keys

You can find the Windows Logo key () and one Application Logo key () on the keyboard, which are used to perform Windows-specific functions, such as opening the Start menu and launching the shortcut menu. For more information of the two keys, please refer to your Windows manual or online help.

n [Fn] Key

 + 	Switch the display output mode between the LCD, external monitor and Both.
 + 	Disable/enable Touchpad.
 + 	Decrease the LCD brightness.

 + 	Increase the LCD brightness.
 + 	Decrease the built-in speaker's volume.
 + 	Increase the built-in speaker's volume.
 + 	Disable the Notebook's audio function.
 + 	Force the Notebook into suspend mode (depending on the system configuration).