Bluetooth® 4.1 Stereo Audio Module

Features:

- Complete, Fully Certified, Embedded 2.4 GHz Bluetooth® Version 4.1 Module
- Bluetooth Classic (BDR/EDR)
- Bluetooth SIG Certified
- Onboard embedded Bluetooth Stack
- Transparent UART mode for seamless serial data over UART interface
- Easy to configure with Windows GUI or direct by MCU
- Firmware can be field upgradable via UART
- Compact surface mount module: 29 x 15 x 2.5 mm³
- Castellated surface mount pads for easy and reliable host PCB mounting
- Environmentally friendly, RoHS compliant
- Perfect for Portable Battery Operated Devices
- Internal Battery Regulator Circuitry
- Worldwide regulatory certifications
- Audio-In / Out
 - BM23 support digital audio I²S format.
 - BM20 support analog audio output.

Operational:

- Operating voltage: 3.0V to 4.2V
- Temperature range: -20°C to 70°C
- Simple, UART interface
- Integrated crystal, internal voltage regulator, and matching circuitry
- Multiple I/O pins for control and status

RF/Analog:

- Frequency: 2.402 to 2.480 GHz
- Receive Sensitivity: -91 dBm (2Mbps EDR)
- Power Output: class 2 / +4dBm max.
- Connection Distance: >10m (free space and no interference)

Audio processor

- Support 64 kb/s A-Law or μ -Law PCM format, or CVSD (Continuous Variable Slope Delta Modulation) for SCO channel operation.
- Noise suppression
- Echo suppression
- SBC and optional AAC decoding
- Packet loss concealment
- Build-in four languages (Chinese/ English/

Spanish/ French) voice prompts and 20 events for each one (This function can be set up in "IS20XXS_UI" tool.)

- Support SCMS-T

Audio Codec

- 20 bit DAC and 16 bit ADC codec
- 98dB SNR DAC playback

Peripherals

- Built-in Lithium-ion battery charger (up to 350mA)
- Integrate 3V, 1.8V configurable switching regulator and LDO
- Built-in ADC for battery monitor and voltage sense.
- A line-in port for external audio input
- Two LED drivers

Flexible HCI interface

- High speed HCI-UART (Universal Asynchronous Receiver Transmitter) interface (up to 921600bps)

MAC/Baseband/Higher Layer:

- Secure AES128 encryption
- Bluetooth profiles
 - HFP v1.6
 - HSP v1.1
 - A2DP v1.2
 - AVRCP v1.5
 - SPP v1.0
 - PBAP v1.0

Antenna:

- Printed Antenna

Compliance:

- Bluetooth SIG QDID: 58996
- Module certified for the United States (FCC) and Canada (IC), European Economic Area (CE), Korea (LTA), Taiwan (NCC) and Japan (MIC)

FIGURE 1:



General Description:

Stereo module is a fully-certified Bluetooth® Version 4.1 (BDR/EDR) module for designers who want to add Bluetooth® wireless audio and voice applications to their products.

This Bluetooth SIG certified module provides a complete wireless solution with Bluetooth stack, integrated antenna, and worldwide radio certifications in a compact surface mount package, 29x15x2.5 mm³.

This stereo module built-in Li-Ion charger and BM23 contain a digital audio interface. It supports HSP, HFP, SPP, A2DP, and AVRCP profiles. Both AAC and SBC codecs are supported for A2DP. Note that the customer must connect their own external analog CODEC/DSP/amplifier and MCU for audio output.

Applications:

- Bluetooth sound bar
- Bluetooth stereo speaker phone

Stereo Module

Table of Contents

1.0 DEVICE OVERVIEW	4
2.0 APPLICATION INFORMATION	10
3.0 ELECTRICAL CHARACTERISTICS	18
4.0 PRINTED ANTENNA INFORMATION.....	23
5.0 REFERENCE CIRCUIT	25
6.0 CERTIFICATION INFORMATION	27
7.0 MODULE OUTLINE AND REFLOW PROFILE	29
8.0 PACKAGING AND STORAGE INFORMATION	34
APPENDIX	37

TO OUR VALUED CUSTOMERS

It is our intention to provide our valued customers with the best documentation possible to ensure successful use of your Microchip products. To this end, we will continue to improve our publications to better suit your needs. Our publications will be refined and enhanced as new volumes and updates are introduced.

If you have any questions or comments regarding this publication, please contact the Marketing Communications Department via E-mail at docerrors@microchip.com. We welcome your feedback.

Most Current Data Sheet

To obtain the most up-to-date version of this data sheet, please register at our Worldwide Web site at:

<http://www.microchip.com>

You can determine the version of a data sheet by examining its literature number found on the bottom outside corner of any page. The last character of the literature number is the version number, (e.g., DS30000000A is version A of document DS30000000).

Errata

An errata sheet, describing minor operational differences from the data sheet and recommended workarounds, may exist for current devices. As device/documentation issues become known to us, we will publish an errata sheet. The errata will specify the revision of silicon and revision of document to which it applies.

To determine if an errata sheet exists for a particular device, please check with one of the following:

- Microchip's Worldwide Web site; <http://www.microchip.com>
- Your local Microchip sales office (see last page)

When contacting a sales office, please specify which device, revision of silicon and data sheet (include literature number) you are using.

Customer Notification System

Register on our web site at www.microchip.com to receive the most current information on all of our products.

Abbreviations List:

HFP: Hands-free Profile
AVRCP: Audio Video Remote Control Profile
A2DP: Advanced Audio Distribution Profile
PBAP: Phone Book Access Profile
HSP: Headset Profile
SPP: Serial Port Profile

Stereo Module

1.0 DEVICE OVERVIEW

The stereo module series include BM20 and BM23. The chip integrates Bluetooth 4.1 radio transceiver, PMU and DSP. Figure 1-1 and 1-2 shows the application block diagram.

FIGURE 1-1: BM20 Typical Application

The following depicts an example of BM20 module operate as an independent system or connected to an MCU.

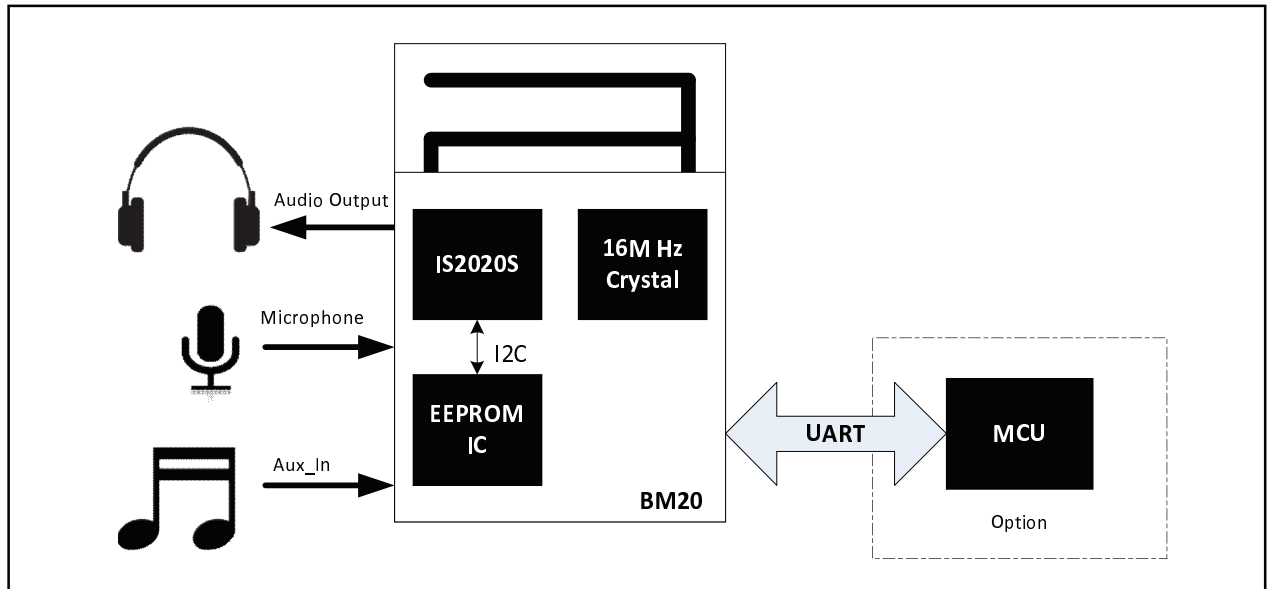
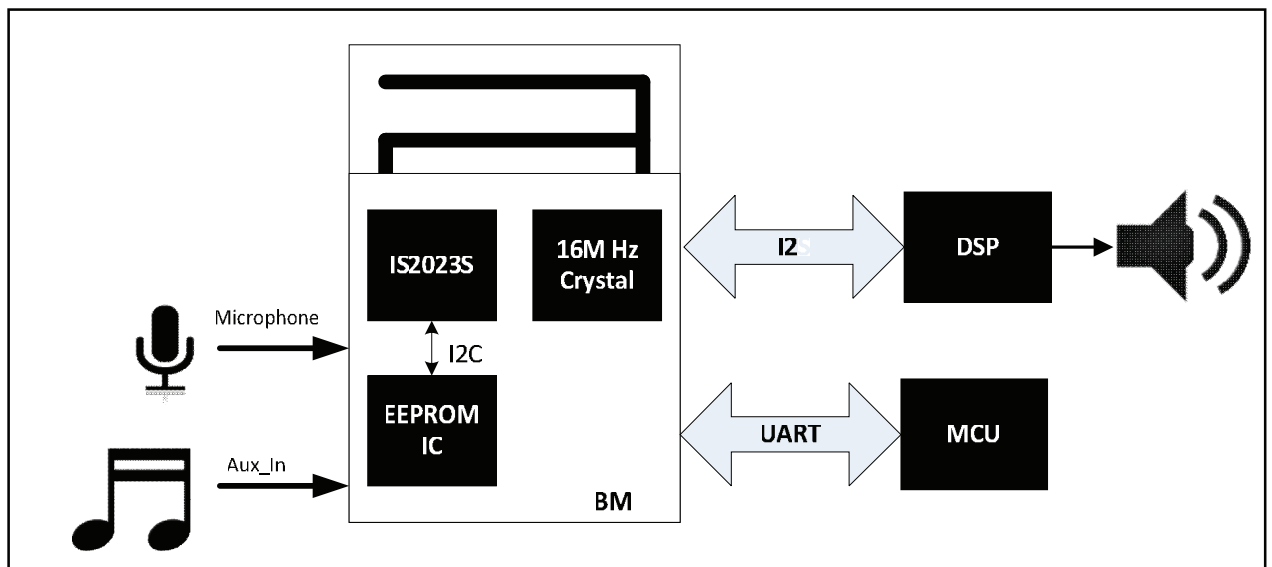

FIGURE 1-2: BM23 Typical Application

The following depicts an example of BM23 module connected to an MCU, external DSP/CODEC.



Stereo Module

1.1 INTERFACE DESCRIPTION

BM20 pin diagram is shown in Figure 1-3. The pin descriptions are shown in Table 1-1

FIGURE 1-3: BM20 PIN DIAGRAM

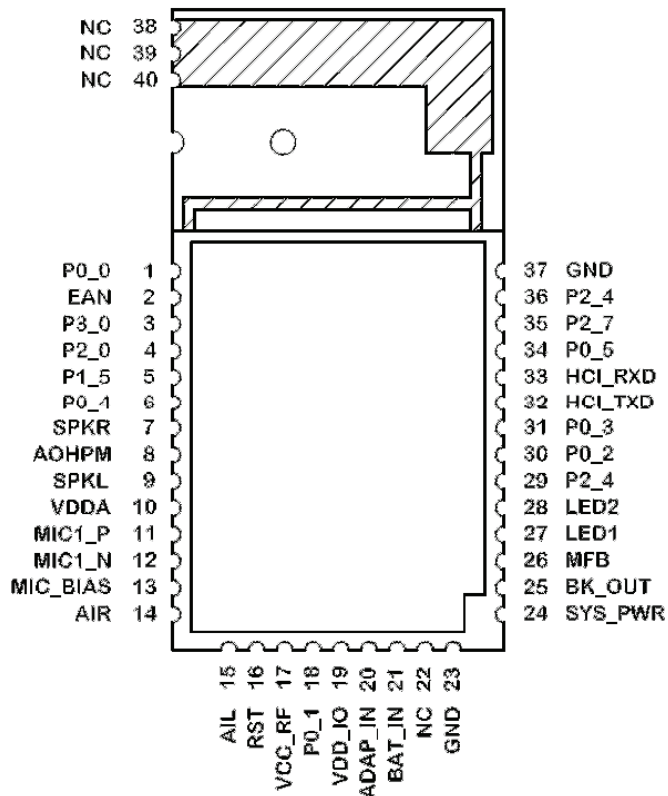

TABLE 1-1: BM20 PIN DESCRIPTION

Pin No.	Pin type	Name	Description
1	I/O	P0_0	IO pin, default pull-high input (Note 1) 1. Slide Switch Detector, active low. 2. UART TX_IND, active low.
2	I	EAN	Embedded ROM/External Flash enable H: Embedded; L: External Flash
3	I	P3_0	IO pin, default pull-high input (Note 1) Line-in Detector (default), active low.
4	I	P2_0	IO pin, default pull-high input System Configuration, H: Application L: Baseband(IBDK Mode)
5	I/O	P1_5	IO pin, default pull-high input (Note 1) 1. NFC detection pin, active low. 2. Out_Ind_0 3. Slide Switch Detector, active low. 4. Buzzer Signal Output
6	I/O	P0_4	IO pin, default pull-high input. (Note 1) 1. NFC detection pin, active low. 2. Out_Ind_0
7	O	SPKR	R-channel analog headphone output
8	O	AOHPM	Headphone common mode output/sense input.

Stereo Module

Pin No.	Pin type	Name	Description
9	O	SPKL	L-channel analog headphone output
10	P	VDDA	Positive power supply/reference voltage for CODEC, no need to add power to this pin.
11	I	MIC1_P	Mic 1 mono differential analog positive input
12	I	MIC1_N	Mic 1 mono differential analog negative input
13	P	MIC_BIAS	Electric microphone biasing voltage
14	I	AIR	R-channel single-ended analog inputs
15	I	AIL	L-channel single-ended analog inputs
16	I	RST	System Reset Pin, Low: reset
17	P	VCC_RF	1.28V RF LDO output, no need to add power to this pin.
18	I/O	P0_1	IO pin, default pull-high input (Note 1) 1. FWD key when class 2 RF (default), active low. 2. Class1 TX Control signal of external RF T/R switch, active high.
19	P	VDD_IO	Power output , no need to add power to this pin
20	P	ADAP_IN	5V Power adaptor input
21	P	BAT_IN	3.3V~4.2V Li-Ion battery input
22	-	NC	No Connection
23	P	GND	Ground Pin
24	P	SYS_PWR	System Power Output BAT mode: 3.3~4.2V Adapter mode: 4.0V
25	P	BK_OUT	1.8V buck output, no need to add power to this pin
26	I	MFB	1. Power key when in off mode 2. UART_RX_IND: MCU use to wakeup BT (Note 1)
27	I	LED1	LED Driver 1
28	I	LED2	LED Driver 2
29	I	P2_4	IO pin, default pull-high input System Configuration, L: Boot Mode with P2_0 low combination
30	I	P0_2	IO pin, default pull-high input (Note 1) Play/Pause key (default), active low.
31	I/O	P0_3	IO pin, default pull-high input (Note 1) 1. REV key (default), active low. 2. Buzzer Signal Output 3. Out_Ind_1 4. Class1 RX Control signal of external RF T/R switch, active high.
32	O	HCI_TXD	HCI-UART TX data
33	I	HCI_RXD	HCI-UART RX data
34	I	P0_5	IO pin, default pull-high input (Note 1) Volume down (default), active low.
35	I	P2_7	IO pin, default pull-high input (Note 1) Volume up key (default), active low.

Stereo Module

Pin No.	Pin type	Name	Description
36	I	P2_4	IO pin, default pull-high input System Configuration, L: Boot Mode with P2_0 low combination
37	P	GND	Ground Pin
38	-	NC	No Connection
39	-	NC	No Connection
40	-	NC	No Connection

- * I: signal input pin
- * O: signal output pin
- * I/O: signal input/output pin
- * P: power pin

Note 1: These button or functions can be setup by “IS20XXS_UI” tool.

Stereo Module

BM23 pin diagram is shown in Figure 1-4. The pin descriptions are shown in Table 1-2

FIGURE 1-4: BM23 PIN DIAGRAM

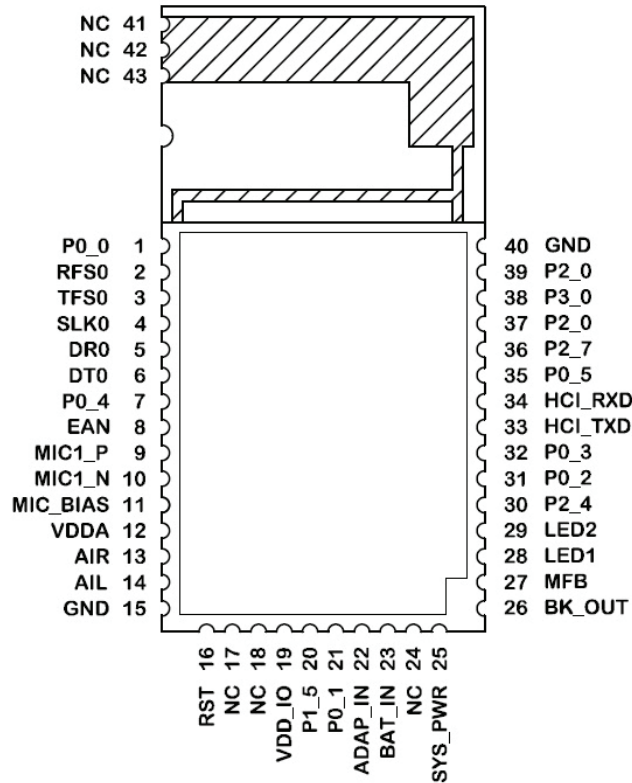

TABLE 1-2: BM23 PIN DESCRIPTION

Pin No.	Pin Type	Name	Description
1	I/O	PO_0	IO pin, default pull-high input (Note 1) UART TX_IND
2	I/O	RFS0	I ² S interface: DAC Left/Right Clock
3	I/O	TFS0	I ² S interface: ADC Left/Right Clock
4	I/O	SLK0	I ² S interface: Bit Clock
5	I	DR0	I ² S interface: DAC Digital Left/Right Data
6	O	DT0	I ² S interface: ADC Digital Left/Right Data
7	I/O	PO_4	IO pin, default pull-high input
8	I	EAN	Embedded ROM/External Flash enable High: ROM mode; Low: External Flash mode
9	I	MIC1_P	Mic 1 mono differential analog positive input
10	I	MIC1_N	Mic 1 mono differential analog negative input
11	P	MIC_BIAS	Power output, microphone biasing voltage
12	P	VDDA	Power output, reserve for external cap to fine tune audio frequency
13	I	AIR	Stereo analog line in, R-channel
14	I	AIL	Stereo analog line in, L-channel

Stereo Module

Pin No.	I/O	Name	Description
15	P	GND	Ground
16	I	RST_N	System Reset Pin, active when rising edge.
17	--	NC	--
18	--	NC	--
19	P	VDDIO	Power output, VDDIO pin, no need to add power to this pin
20	I/O	P1_5	IO pin, default pull-high input
21	I/O	P0_1	IO pin, default pull-high input
22	P	ADAP_IN	5V power adaptor input
23	P	BAT_IN	3.3~4.2V Li-ion battery input
24	--	NC	--
25	P	SYS_PWR	System Power Output BAT mode: 3.3~4.2V Adapter mode: 4.0V
26	P	BK_OUT	Power output, 1v8 pin, no need to add power to this pin
27	P	MFB	1. Power key when in off mode 2. UART_RX_IND: MCU use to wakeup BT
28	P	LED1	LED Driver 1, 4mA max
29	P	LED2	LED Driver 2, 4mA max
30	I	P2_4	IO pin, default pull-high input System Configuration, L: Boot Mode with P2_0 low combination
31	I/O	P0_2	IO pin, default pull-high input
32	I/O	P0_3	IO pin, default pull-high input
33	O	HCI_TXD	HCI-UART TX data
34	I	HCI_RXD	HCI-UART RX data
35	I/O	P0_5	IO pin, default pull-high input
36	I/O	P2_7	IO pin, default pull-high input
37	I/O	P2_0	IO pin, default pull-high input
38	I/O	P3_0	IO pin, default pull-high input
39	I	P2_0	IO pin, default pull-high input System Configuration, H: Application L: Baseband(IBDK Mode)
40	P	GND	Ground.
41	--	NC	--
42	--	NC	--
43	--	NC	--

- * I: signal input pin
- * O: signal output pin
- * I/O: signal input/output pin
- * P: power pin

Note 1: These button or functions can be setup by “IS20XXS_UI” tool.

2.0 APPLICATION INFORMATION

2.1 OPERATION WITH EXTERNAL MCU

Stereo module support UART command set to make an external MCU to control module. Here is the connection interface between BMXX and MCU.

FIGURE 2-1: INTERFACE BETWEEN MCU AND BMXX MODULE

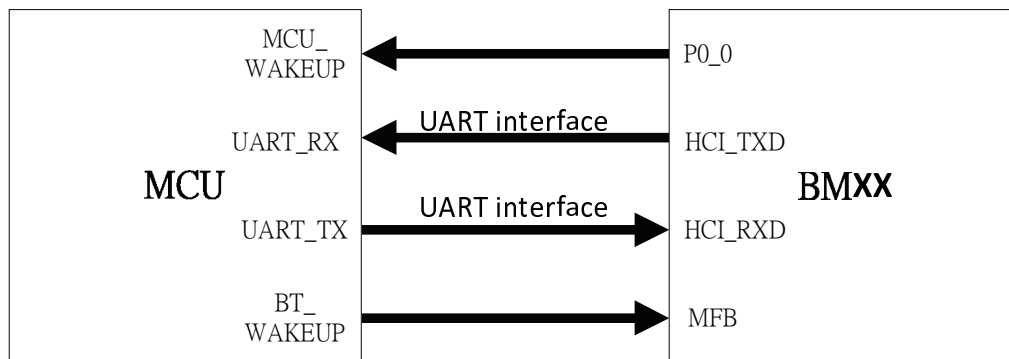

MCU can control module by UART interface and wakeup module by PWR pin. Stereo module provide wakeup MCU function by connect to P0_0 pin of module.

“UART Command Set” document provide all function which module support and UI tool will help you to set up your system support UART command.

For more detail description, please reference “UART_CommandSet_v154” document and “IS20XXS_UI” tool.

Stereo Module

Here are some suggestions of UART control signal timing sequence:
FIGURE 2-2: POWER ON/OFF SEQUENCE

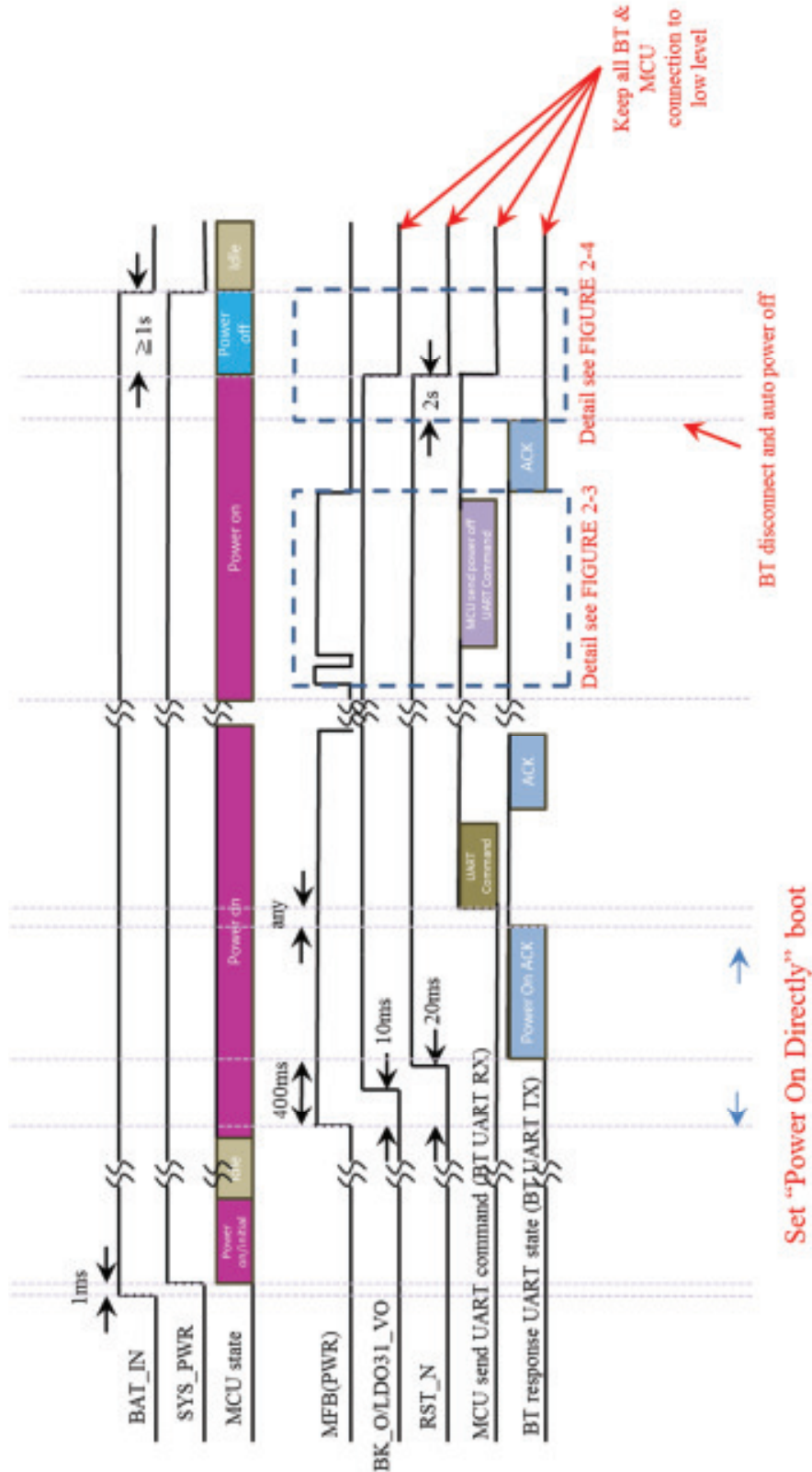

FIGURE 2-3: TIMING SEQUENCE OF RX INDICATION AFTER POWER ON

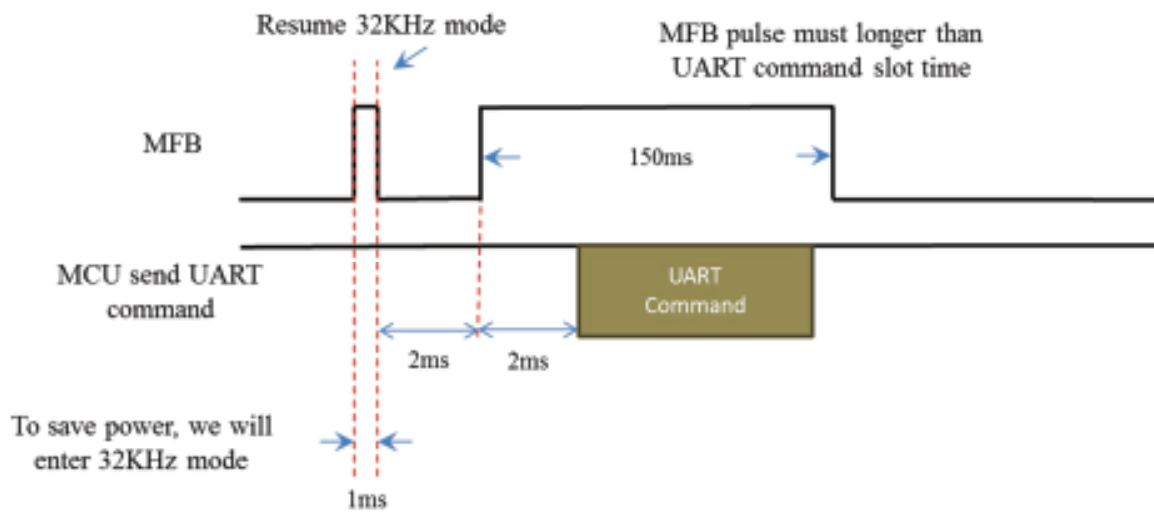
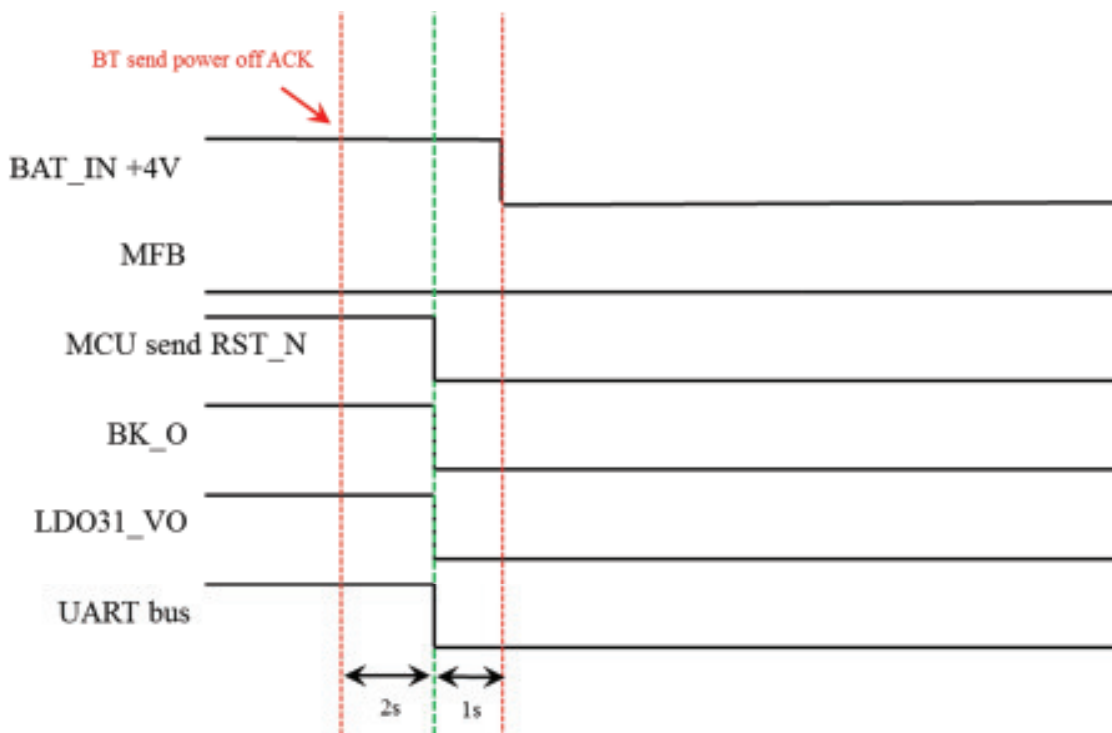

FIGURE 2-4: TIMING SEQUENCE OF POWER OFF



EEPROM clock= 100KHz
 For a byte write, $0.01\text{ms} \times 32\text{clock} \times 2 = 640\text{us}$
 If power drop faster than 640us, some issue may occurs, but the possibility is low

Stereo Module

FIGURE 2-5: TIMING SEQUENCE OF POWER ON (NACK)

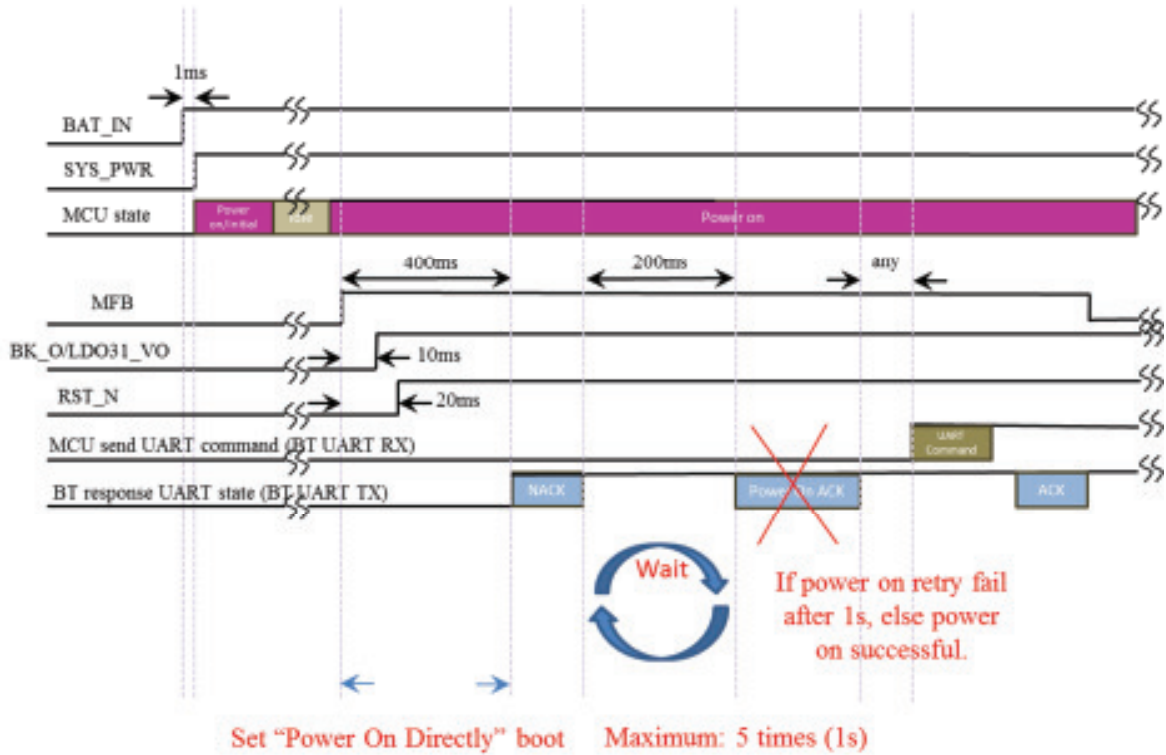

FIGURE 2-6: RESET TIMING SEQUENCE IF MODULE HANGS UP

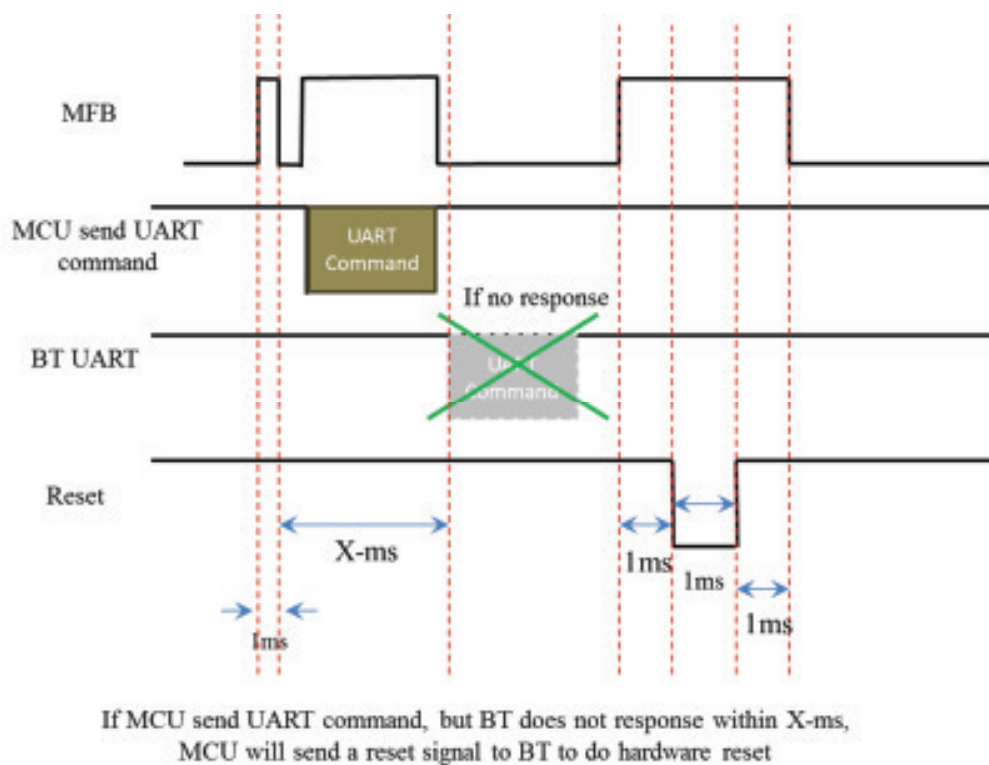
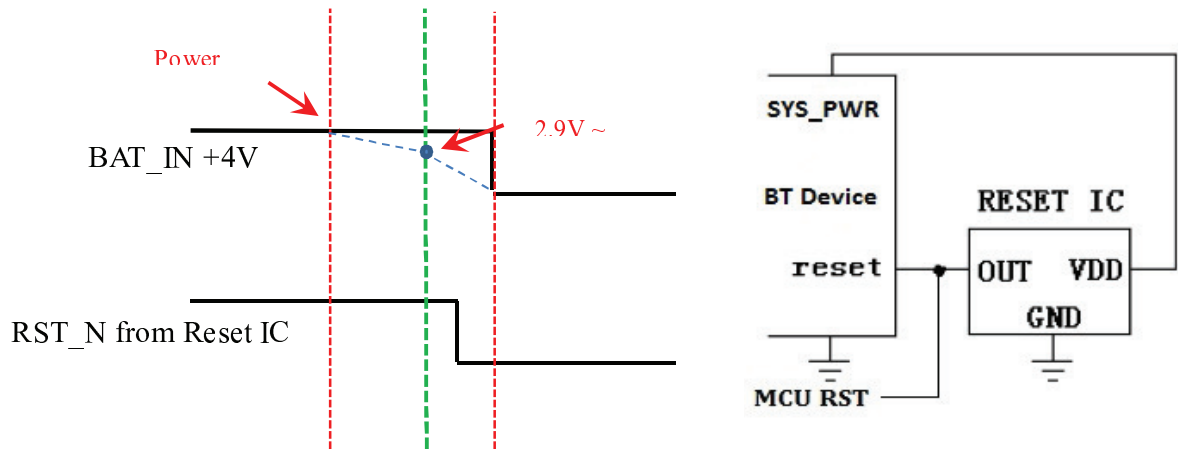

FIGURE 2-7: TIMING SEQUENCE OF POWER DROP PROTECTION



If BT's BAT use adaptor translates voltage by LDO, we recommend use "Reset IC" to avoid power off suddenly. Rest IC spec output pin must be "Open Drain" · delay time $\leq 10\text{ms}$

Recommend part: TCM809SVNB713 or G691L263T73

2.2 I²S Signal Application for BM23

BM23 support I²S digital audio signal interface to connect your external CODEC/DSP. It provide 8k Hz, 44.1k Hz and 48k Hz sampling rate; it also support 16 bits and 24bits data format. The I²S setting can be set up by UI and DSP tools.

The external CODEC/DSP needs to be connected to SLK0, RFS0, TFS0, DR0, and DT0 (pins 4, 2, 3, 5, and 6 respectively). The I²S signal connection between BM23 and external DSP as below:

FIGURE 2-9: MASTER MODE REFERENCE CONNECTION

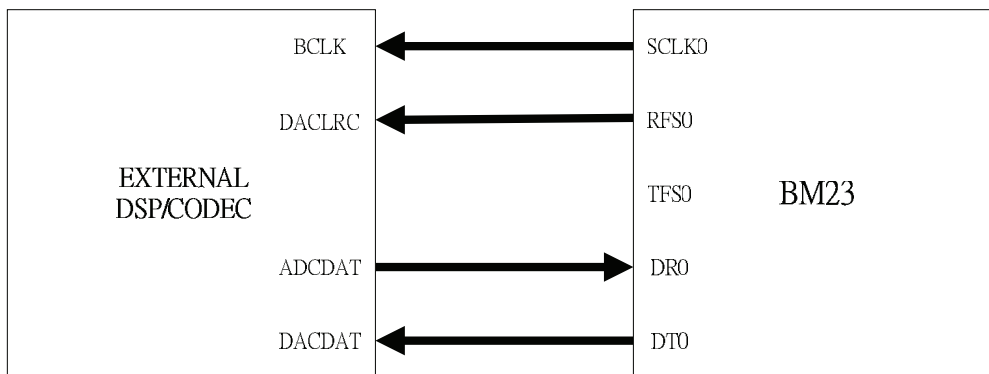
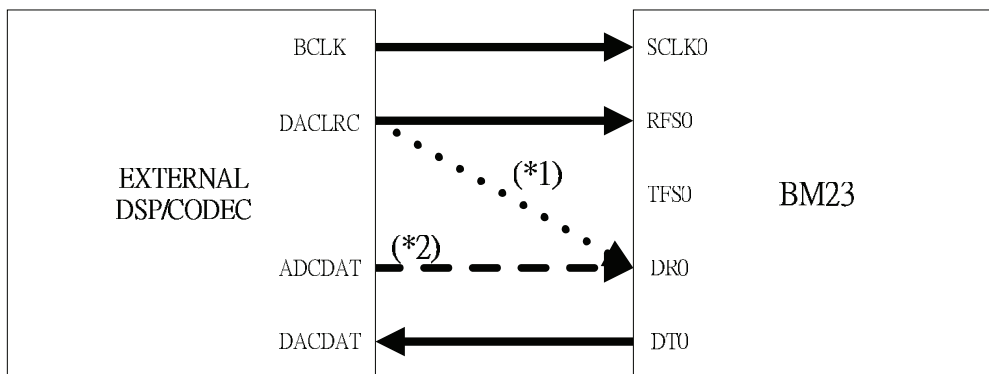

FIGURE 2-10: SLAVE MODE REFERENCE CONNECTION



Note 1: For 002 version chip or module, system should connect line 1 in slave mode figure.

And, system not support ADC signal from external DSP/CODEC.

Note 2: For other version chip or module, system should connect line 2 in slave mode figure.

About "Mast" or "Slave" mode setting, you can use "DSP Configuration Tool" to set up system.

Stereo Module

The clock and data timing as below:

FIGURE 2-11: TIMING FOR I²S MODES (both master and slave)

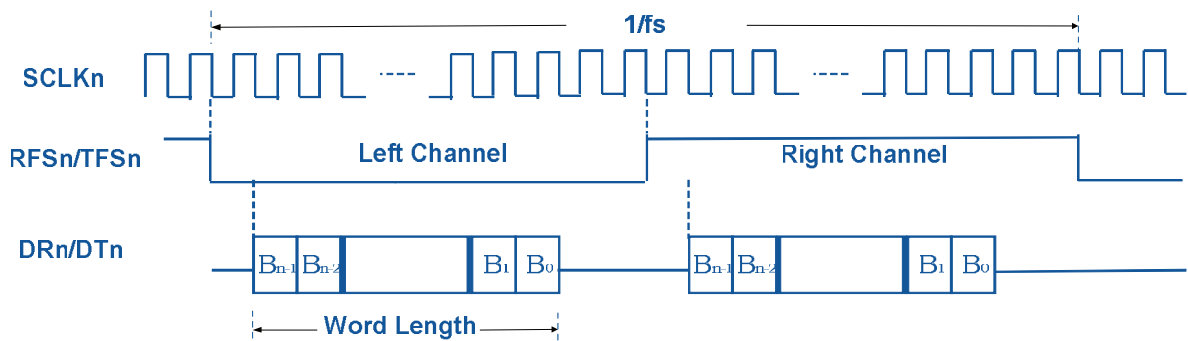
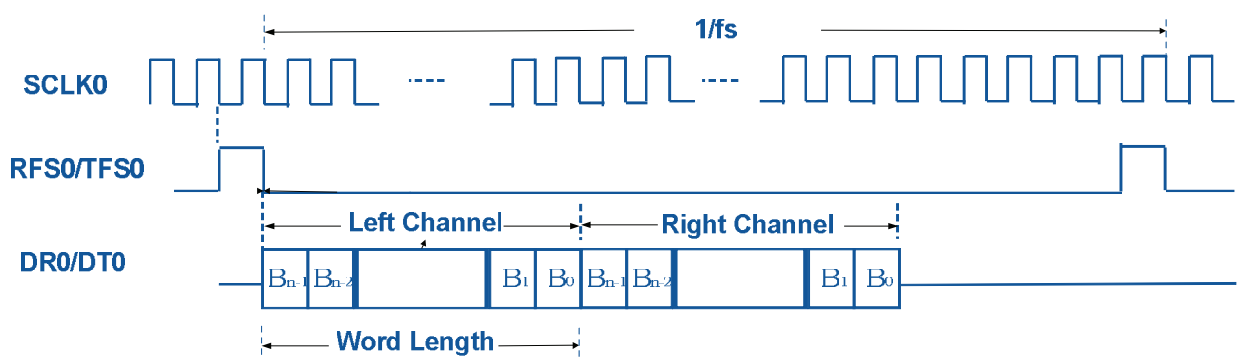

FIGURE 2-12: TIMING FOR PCM MODES (both master and slave)



2.3 RESET (RST_N)

RST is module reset pin which is active LOW. To reset the module, the RST_N must hold LOW for at least 63ns.

2.4 STATUS LED (LED1, LED2)

The status LED provide below status indication:

- Standby
- Inquiry
- Link
- Link Back
- Low Battery
- Page
- Battery Charging

Each status indication LED flashing sequence and brightness is configurable by UI tool.

Stereo Module

2.5 EXTERNAL CONFIGURATION

Stereo module can be configured and firmware programmed using an external configuration and programming tool available from Microchip. Figure 2-7 shows the configuration and firmware programming interface on BM23. It is recommended to include a pin header on the main PCB for development.

Configuration and firmware programming modes are entered accordingly to the system configuration I/O pins as shown in Table 2-1. Pin P20, P24 and EAN pin have internal pull-up.

FIGURE 2-13: EXTERNAL PROGRAMMING HEADER CONNECTIONS

(Here is the interface connect example of the BM23)

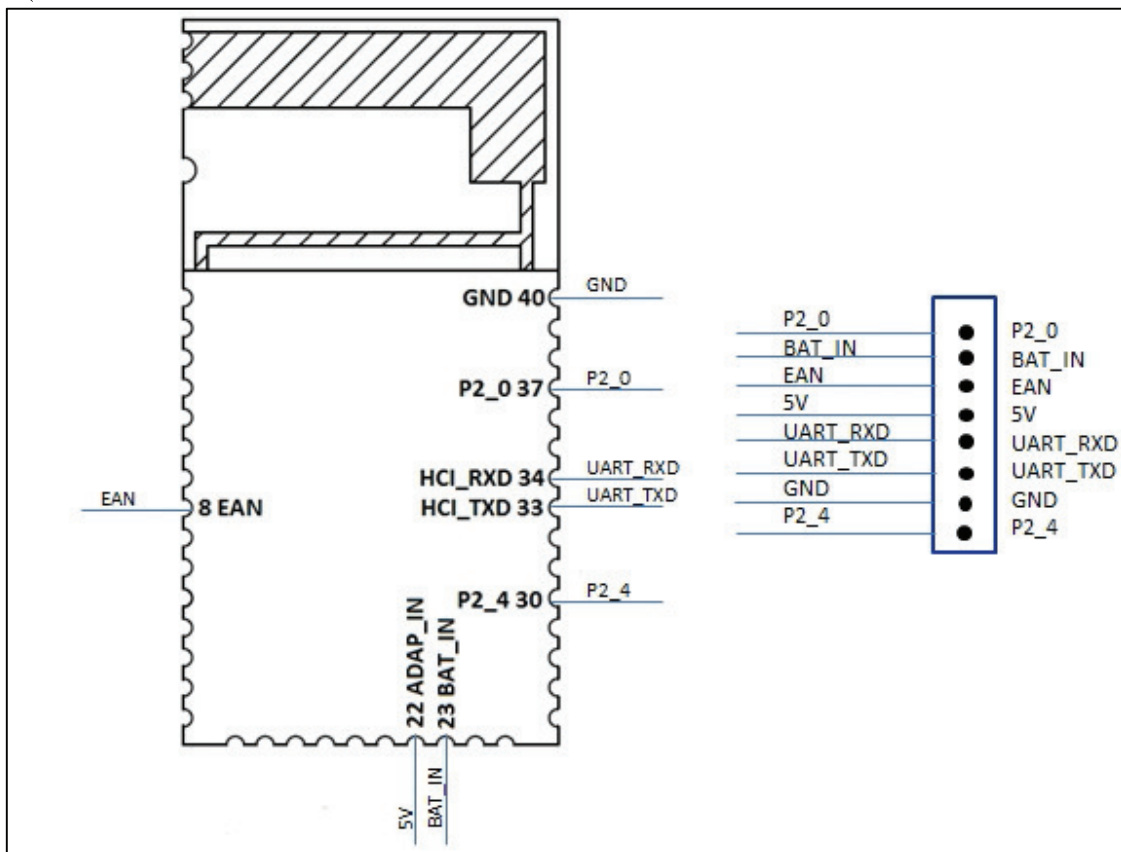

TABLE 2-1: SYSTEM CONFIGURATION SETTINGS

P20	P24	EAN	Operational Mode
High	High	High	APP mode (Normal operation)
Low	High	High	Test mode (Write EEPROM)
Low	Low	High	Write Flash (Firmware programming if flash build-in in chip)

Stereo Module

3.0 ELECTRICAL CHARACTERISTICS

Table 3-1: ABSOLUTE MAXIMUM SPECIFICATION

Symbol	Parameter	Min	Max	Unit
BAT_IN	Input voltage for battery	0	4.3	V
ADAP_IN	Input voltage for adaptor	0	7.0	V
T _{STORE}	Storage temperature	-65	+150	°C
T _{OPERATION}	Operation temperature	-20	+70	°C

Table 3-2: RECOMMENDED OPERATING CONDITION

Symbol	Parameter	Min	Typical	Max	Unit
BAT_IN	Input voltage for battery	3	3.7	4.2	V
ADAP_IN	Input voltage for adaptor	4.5	5	5.5	V
T _{OPERATION}	Operation temperature	-20	+25	+70	°C

Note:

Absolute and Recommended operating condition tables reflect typical usage for device.

TABLE 3-3: I/O AND RESET LEVEL

Parameter	Min.	Typ.	Max.	Units
I/O Supply Voltage (VDD_IO)	2.7	3.0	3.3	V
I/O Voltage Levels				
V _{IL} input logic levels low	-0.3		0.8	V
V _{IH} input logic levels high	2.0		3.6	V
V _{OL} output logic levels low			0.4	V
V _{OH} output logic levels high	2.4			V
RESET				
V _{TH,RES} threshold voltage		1.6		V

Note:

(1) VDD_IO voltage is programmable by EEPROM parameters.

(2) These parameters are characterized but not tested in manufacturing.

Stereo Module

Table 3-4: BATTERY CHARGER

Parameter	Min	Typical	Max	Unit	
ADAP_IN Input Voltage	4.5	5.0	5.5	V	
Supply current to charger only		3	4.5	mA	
Maximum Battery Fast Charge Current Note: ENX2=0	Headroom > 0.7V (ADAP_IN=5V)	170	200	240	mA
	Headroom = 0.3V (ADAP_IN=4.5V)	160	180	240	mA
Maximum Battery Fast Charge Current Note: ENX2=1	Headroom > 0.7V (ADAP_IN=5V)	330	350	420	mA
	Headroom = 0.3V (ADAP_IN=4.5V)	180	220	270	mA
Trickle Charge Voltage Threshold		3		V	
Battery Charge Termination Current, (% of Fast Charge Current)		10		%	

Note:

- (1) Headroom = $V_{ADAP_IN} - V_{BAT}$
- (2) ENX2 is not allowed to be enabled when $V_{ADAP_IN} - V_{BAT} > 2V$
- (3) These parameters are characterized but not tested in manufacturing.

Table 3-5: LED DRIVER

Parameter	Min	Typical	Max	Unit
Open-drain Voltage			3.6	V
Programmable Current Range	0		5.25	mA
Intensity Control		16		step
Current Step		0.35		mA
Power Down Open-drain Current			1	μA
Shutdown Current			1	μA

Note:

- (1) Test condition: SAR_VDD=1.8V, temperature=25 °C.
- (2) These parameters are characterized but not tested in manufacturing.

Stereo Module

Table 3-6: AUDIO CODEC ANALOGUE TO DIGITAL CONVERTER

T= 25°C, V_{dd}=3.0V, 1KHz sine wave input, Bandwidth = 20Hz~20KHz

Parameter (Condition)	Min.	Typ.	Max.	Unit
Resolution			16	Bits
Output Sample Rate	8		48	KHz
Signal to Noise Ratio Note: 1 (SNR @MIC or Line-in mode)		88		dB
Digital Gain	-54		4.85	dB
Digital Gain Resolution		2~6		dB
MIC Boost Gain		20		dB
Analog Gain			60	dB
Analog Gain Resolution		2.0		dB
Input full-scale at maximum gain (differential)		4		mV rms
Input full-scale at minimum gain (differential)		800		mV rms
3dB bandwidth		20		KHz
Microphone mode (input impedance)		24		KΩ
THD+N (microphone input) @30mVrms input		0.02		%

Note:

- (1) f_{in} =1KHz, B/W=20~20KHz, A-weighted, THD+N < 1%, 150mV_{pp} input
- (2) These parameters are characterized but not tested in manufacturing.

Stereo Module

Table 3-7: AUDIO CODEC DIGITAL TO ANALOGUE CONVERTER

T= 25°C, V _{dd} =3.0V, 1KHz sine wave input, Bandwidth = 20Hz~20KHz					
Parameter (Condition)	Min.	Typ.	Max.	Unit	
Over-sampling rate		128		f _s	
Resolution	16		20	Bits	
Output Sample Rate	8		48	KHz	
Signal to Noise Ratio <small>Note: 1</small> (SNR @cap-less mode) for 48kHz		96		dB	
Signal to Noise Ratio <small>Note: 1</small> (SNR @single-end mode) for 48kHz		98		dB	
Digital Gain	-54		4.85	dB	
Digital Gain Resolution		2~6		dB	
Analog Gain	-28		3	dB	
Analog Gain Resolution		1		dB	
Output Voltage Full-scale Swing (AVDD=2.8V)	495	742.5		mV rms	
Maximum Output Power (16Ω load)		34.5		mW	
Maximum Output Power (32Ω load)		17.2		mW	
Allowed Load	Resistive	8	16	O.C.	Ω
	Capacitive			500	pF
THD+N (16Ω load)			0.05	%	
Signal to Noise Ratio (SNR @ 16Ω load)			96	dB	

Note:

- (1) f_{in}=1KHz, B/W=20~20KHz, A-weighted, THD+N < 0.01%, 0dBFS signal, Load=100KΩ
 (2) These parameters are characterized but not tested in manufacturing.

Table 3-8: TRANSMITTER SECTION FOR BDR AND EDR

Parameter	Min	Typ	Max	Bluetooth specification	Unit
Maximum RF transmit power		3.0	4.0	-6 to 4	dBm
EDR/BDR Relative transmit power	-4	-1.2	1	-4 to 1	dB

Note:

The RF Transmit power is calibrated during production using MP Tool software and MT8852 Bluetooth Test equipment.

Test condition: VCC_RF= 1.28V, temperature=25 °C.

Stereo Module

Table 3-9: RECEIVER SECTION FOR BDR AND EDR

	Modulation	Min	Typ	Max	Bluetooth specification	Unit
Sensitivity at 0.1% BER	GFSK		-90		≤-70	dBm
Sensitivity at 0.01% BER	π/4 DQPSK		-91		≤-70	dBm
	8DPSK		-82		≤-70	dBm

Note:

- (1) Test condition: VCC_RF= 1.28V, temperature=25 °C.
- (2) These parameters are characterized but not tested in manufacturing.

Table 3-10: SYSTEM CURRENT CONSUMPTION OF ANALOG AUDIO OUTPUT

System Status	Typ.	Max.	Unit
System Off Mode	2	5	uA
Standby Mode	0.8		mA
Linked Mode	0.4		mA
SCO Link	7.8		mA
A2DP Link (V _{pp} =200mV; 1k tone signal)	10.7		mA

Note: Use BM20 EVB as test platform.

Test condition: BAT_IN= 3.8V, link with HTC EYE cell phone; distance between cell phone and EVB: 30cm.

Table 3-11: SYSTEM CURRENT CONSUMPTION OF DIGITAL AUDIO OUTPUT(I²S)

System Status	Typ.	Max.	Unit
System Off Mode	2	5	uA
Standby Mode	0.4		mA
Linked Mode	0.4		mA
SCO Link	9.3		mA
A2DP Link (1k tone signal)	11.7		mA

Note: Use BM23 EVB as test platform

Test condition: BAT_IN= 3.8V, link with HTC M8 cell phone; distance between cell phone and EVB: 30cm; I²S signal link with YAMAHA YDA174 EVB

4.0 PRINTED ANTENNA INFORMATION

4.1 MODULE RADIATION PATTERN

The stereo module contains a PCB printed antenna. The PCB printed antenna radiation pattern is shown in Figure 4-2.

FIGURE 4-1: ANTENNA KEEP OUT AREA EXAMPLES

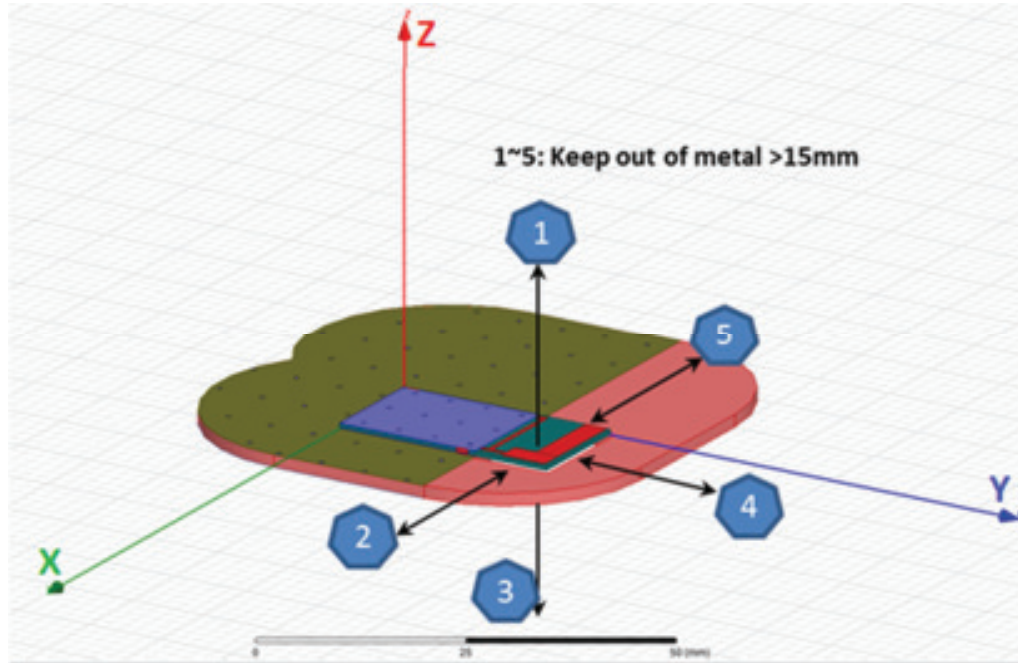
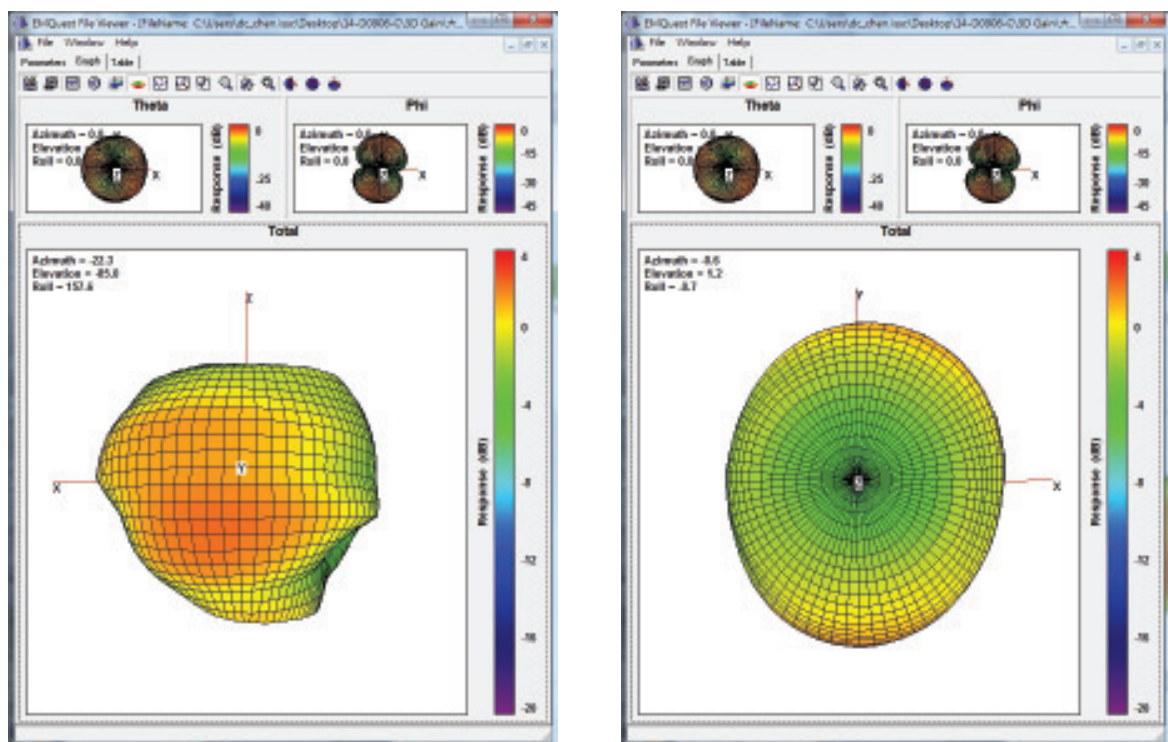

FIGURE 4-2: ANTENNA 3D RADIATION PATTERN @2441 MHz



4.2 MODULE PLACEMENT RULE

On the main PCB, the areas under the antenna should not contain any top, inner layer, or bottom copper as shown in Figure 4-1. A low-impedance ground plane will ensure the best radio performance (best range, lowest noise). The ground plane can be extended beyond the minimum recommended as need for the main PCB EMC noise reduction. For the best range performance, keep all external metal away from the ceramic chip antenna at least 15 mm.

Here are some examples of good and poor placement on a carrier board with GND plane.

FIGURE 4-3: MODULE PLACEMENT EXAMPLES

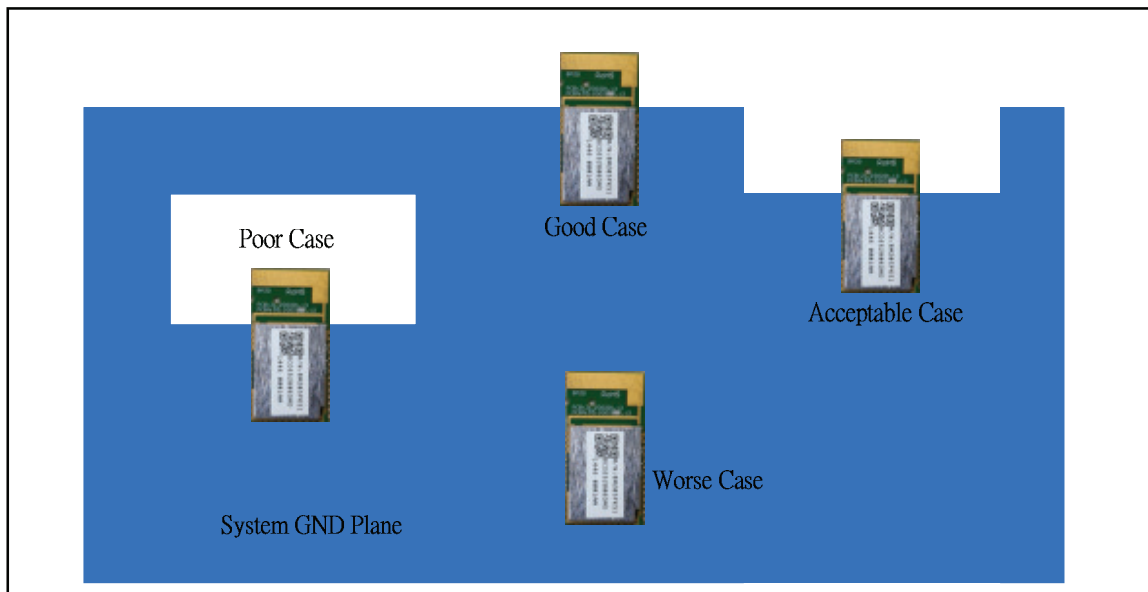
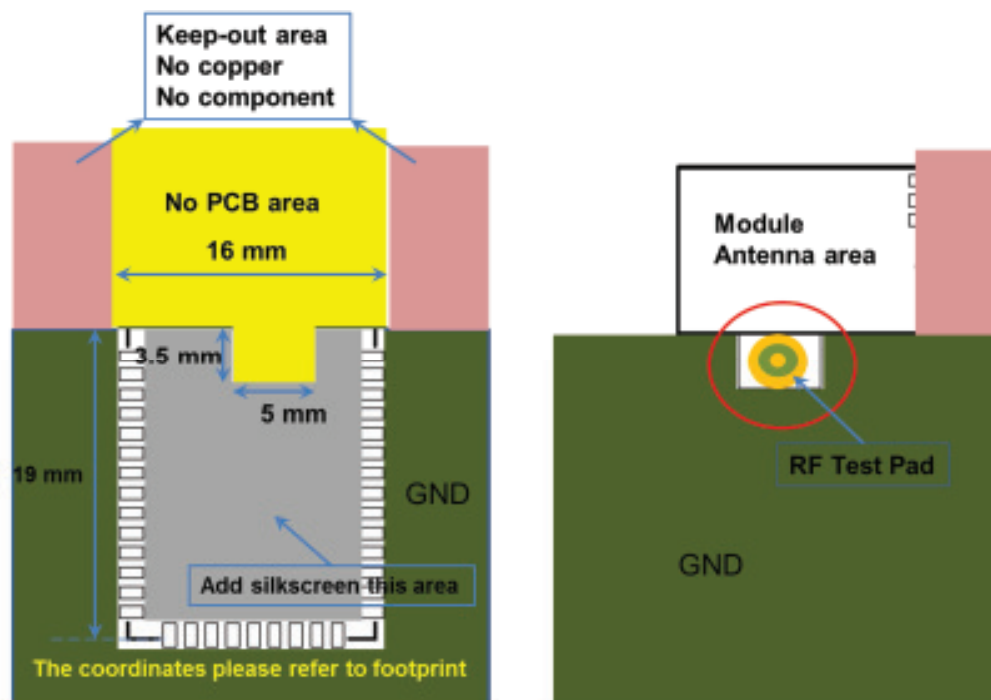
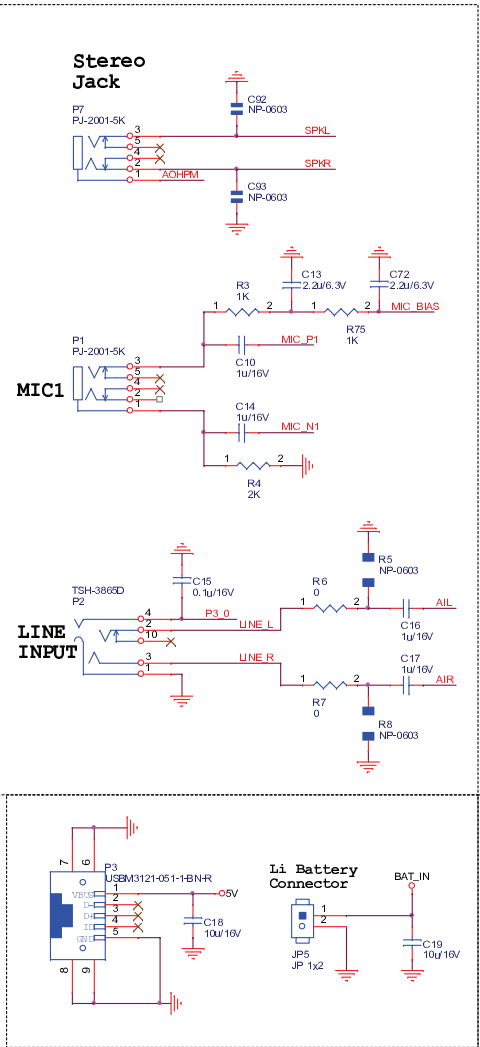
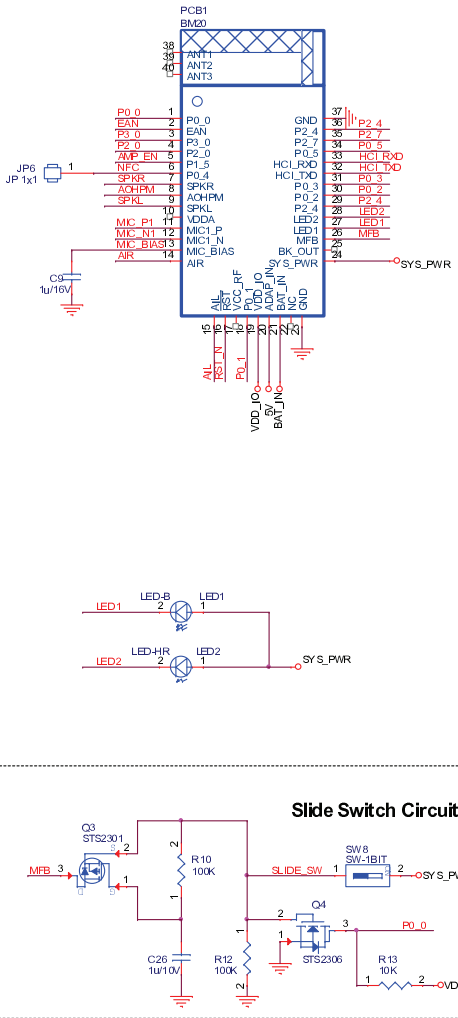
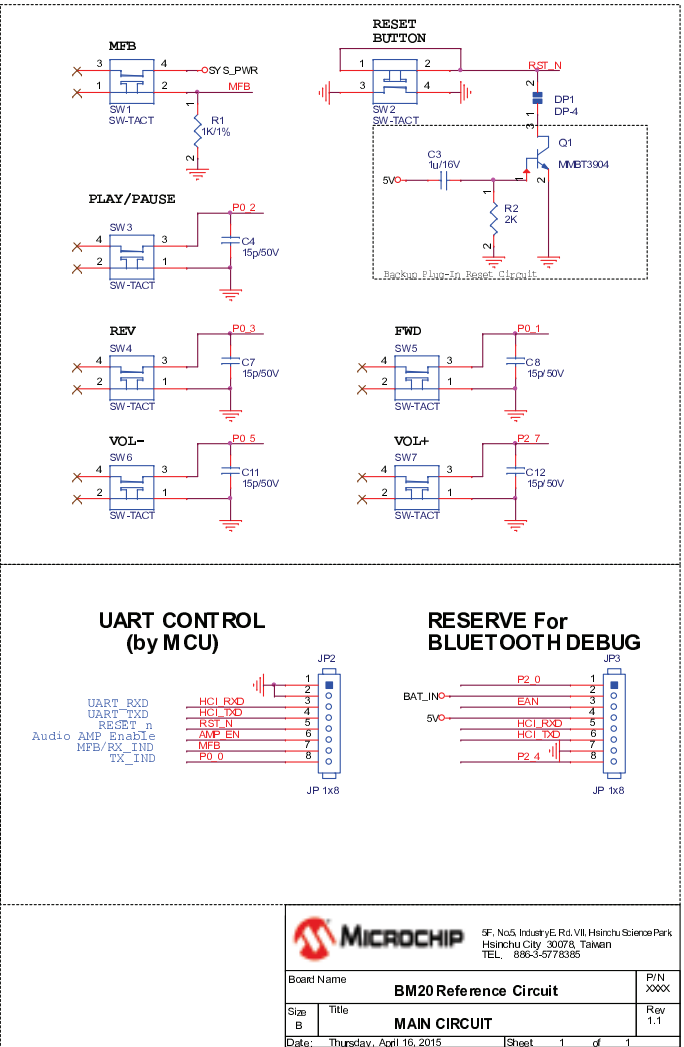

FIGURE 4-4: GND PLANE ON MAIN APPLICATION BOARD



5.0 REFERENCE CIRCUIT 5.1 BM20 REFERENCE CIRCUIT



		5F, No.5, Industry E. Rd, VII, Hsinchu Science Park Hsinchu City, 30078, Taiwan TEL: 886-3-5778385
Board Name	BM20 Reference Circuit	PIN XXXX
Size	B	Rev 1.1
Title		MAIN CIRCUIT
Date:	Thursday, April 16, 2015	Sheet 1 of 1

UART CONTROL (by MCU)

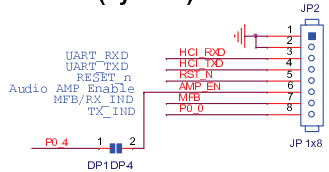

RESERVE For BLUETOOTH DEBUG

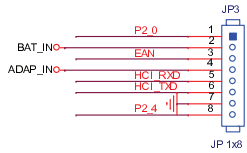

GPIO Description

P0_0	UART_TX_IND(Flash)
P0_4	Audio AMP Enable(ROM)
P2_0	System Configuration
P2_4	System Configuration
P3_0	LINE IN Detection
MFB	PWR/MFB/UART_RX_IND
EAN	System Configuration

MICROCHIP 5F, No.5 Industry E Rd, VII, Hsinchu Science Park, Hsinchu City, 30073, Taiwan
 TEL: 886-3-5778385

Board Name	Reference Circuit of BM23	PN	XXXX
Size	B	Title	Reference Circuit of BM23
Date:	Friday, March 13, 2015	Sheet	2 of 2
		Rev	1.0

I2S INTERFACE

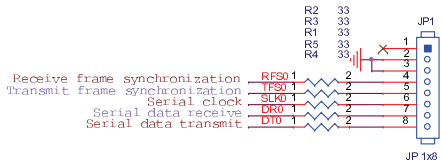

MIC INPUT

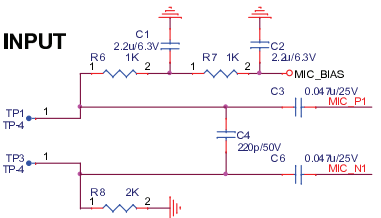

STEREO AUX LINE INPUT

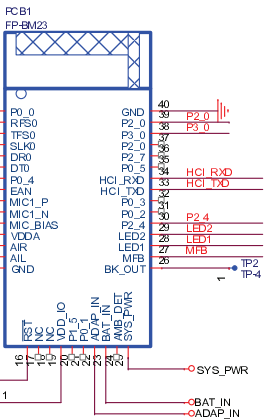
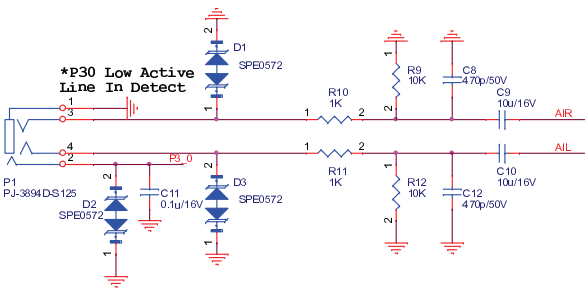

LED

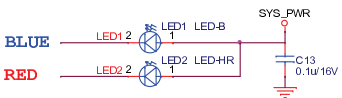

DC POWER SOURCE

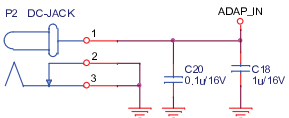

BATTERY CONNECTOR

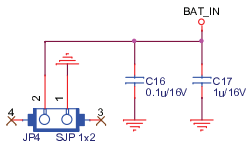

6.0 CERTIFICATION INFORMATION

6.1 BQTF INFORMATION

FIGURE 6-1: BM15/BM20/BM23/BM25 QDID Data

[<< Go Back <<](#)
[>> DISPLAY ICS DETAILS >>](#)

TPG Project	KleanWire IS2000 series (End Product)				
Member Company	ISSC Technologies Corp.				
Declaration ID	D023460				
QD ID	58996 Export ICS				
PRD 1.0 ID (QP ID)					
Wi-Fi® Certification ID					
Subsetted Projects	Date Created	Type	ICS		
	Jul 10, 2014	Main	ICS		
	Jul 13, 2014	Subset	ICS		
	Jul 14, 2014	Subset	ICS		
	Jul 14, 2014	Subset	ICS		
	Jul 14, 2014	Subset	ICS		
	Jul 14, 2014	Subset	ICS		
	Jul 14, 2014	Subset	ICS		
	Jul 14, 2014	Subset	ICS		
	Jul 14, 2014	Subset	ICS		
	Jul 14, 2014	Subset	ICS		
Design Name	ISSC BT4.1 KleanWire IS2000 series				
Design Model Number	BM15SPKXY/ BM20SPKXY/ BM23SPKXY/ BM25SPKXY X=A~Z,0~9, Y=0~9				
Hardware Version Number	IS2000				
Software Version Number	IS2000				
Qualification Assessment Date	July/13/2014				
Listing Date	July/14/2014				
Design Description	Bluetooth speaker/headset				
Product Type	End Product				
Specification Name	4.1				
Product List					
Brand	Model	URL	Description	Subset ID	Publish Date
	BM15SPKXY/ BM20SPKXY/ BM23SPKXY/ BM25SPKXY X=A~Z,0~9, Y=0~9		Bluetooth speaker/headset		Jul 14, 2014
	Technical Data Sheet (RIN)	(not available)			
Listed By	mei feng Huang				
BQE	Frankie Lin				
Referenced QDID Profile Information					
➤ QDID: 58996					

6.2 REGULATORY APPROVAL

BM23 has got these countries regulatory approval:

- United States; FCC ID: A8TBM23SPKXYC2A
- Canada; IC ID: 12246A-BM23SPKXYC2
- Europe
- Japan: 202-SMC067
- Korea; Certification No.: MSIP-CRM-S9S-BM23SPKXY
- Taiwan; NCC No.: CCAL15LP0270T3

BM20 has got these countries regulatory approval:

- United States: FCC ID: A8TBM20SPKXYNBZ
- Canada; IC ID: 12246A-BM20SPKS1
- Europe
- Japan: 202-SMD048
- Korea; Certification No.: MSIP-CRM-mcp-BM20SPKS1NBC
- Taiwan; NCC No.: CCAN15LP0460T2

For more information, please reference appendix.

Stereo Module

7.0 MODULE OUTLINE AND REFLOW PROFILE 7.1 MODULE DIMENSION AND PCB FOOT PRINT

FIGURE 7-1: BM20 Outline Dimension

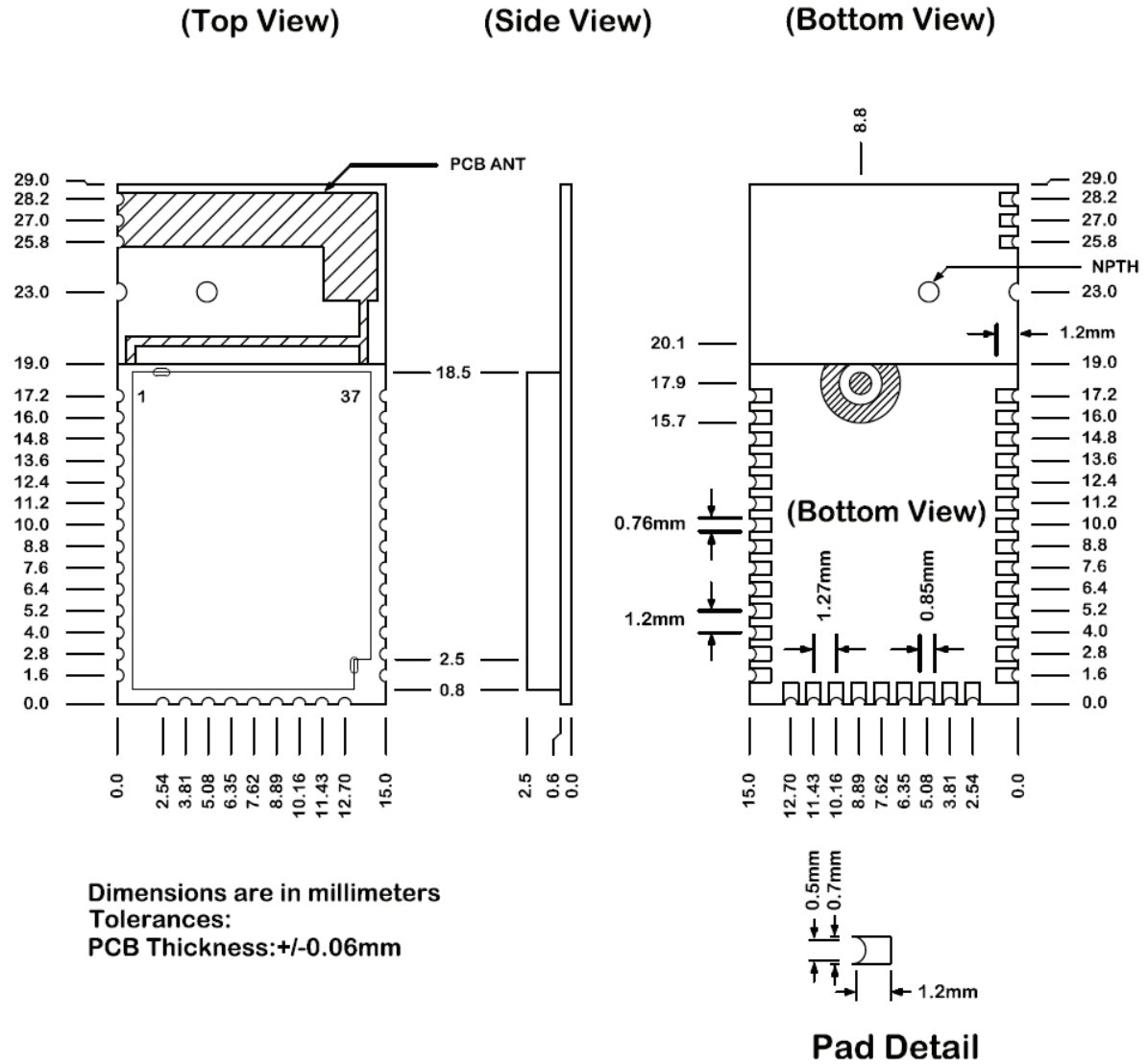

PCB dimension:

X : 15.0 mm

Y : 29.0 mm

Tolerances: 0.25 mm

Stereo Module

FIGURE 7-2: BM23 Outline Dimension

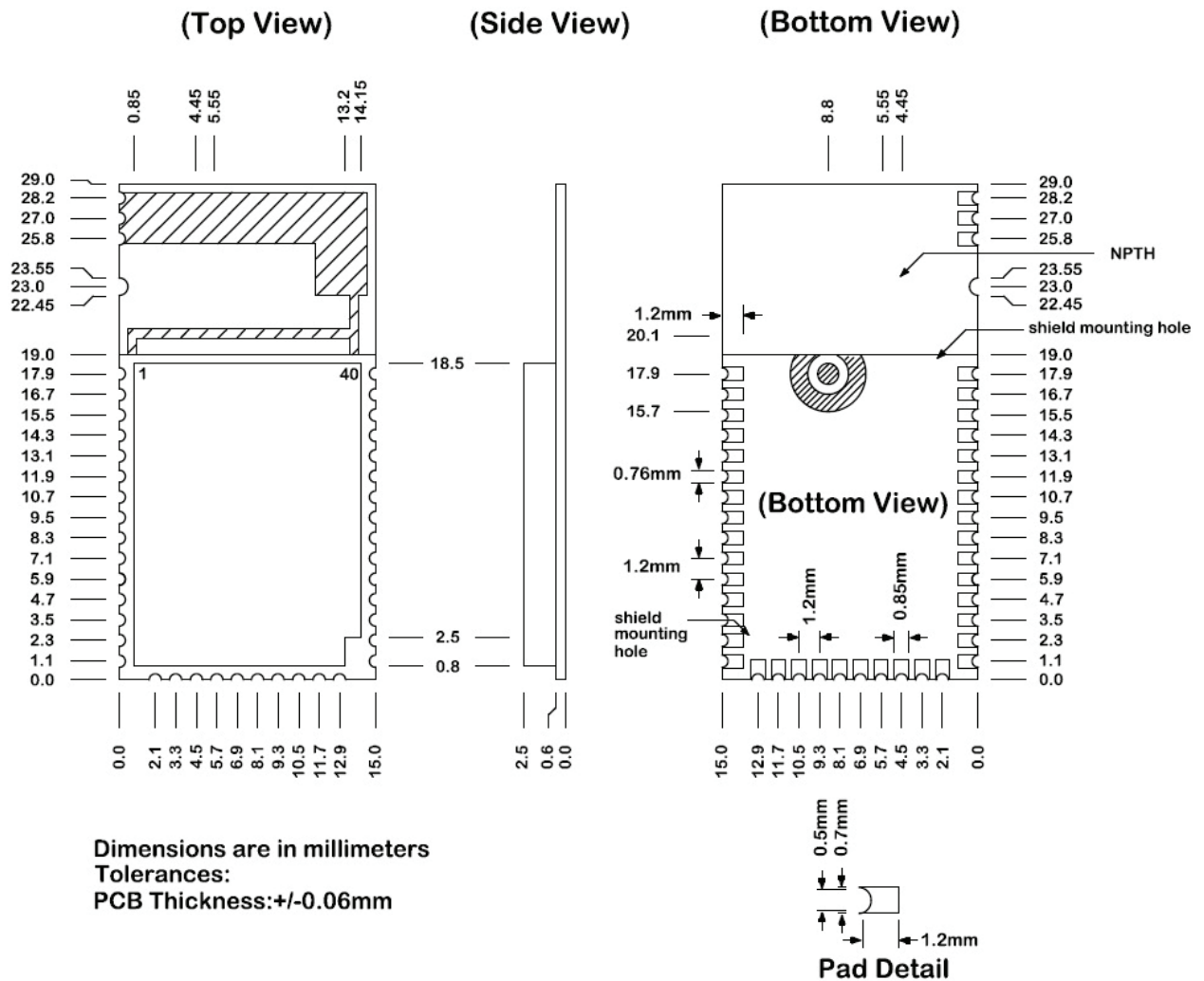

PCB dimension:

X : 15.0 mm

Y : 29.0 mm

Tolerances: 0.25 mm

Stereo Module

FIGURE 7-3: BM20 PCB FOOT PRINT

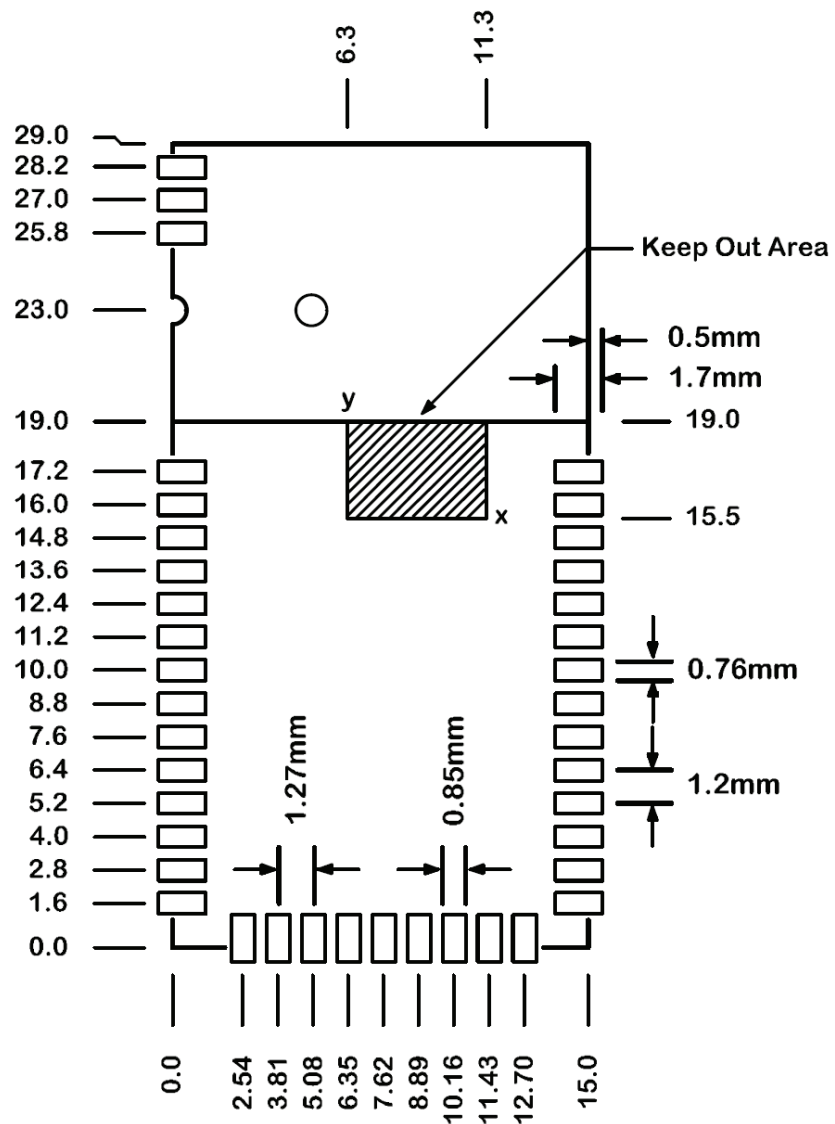

Note: The "Keep Out Area" is reserved for RF performance check.

Stereo Module

FIGURE 7-4: BM23 PCB FOOT PRINT

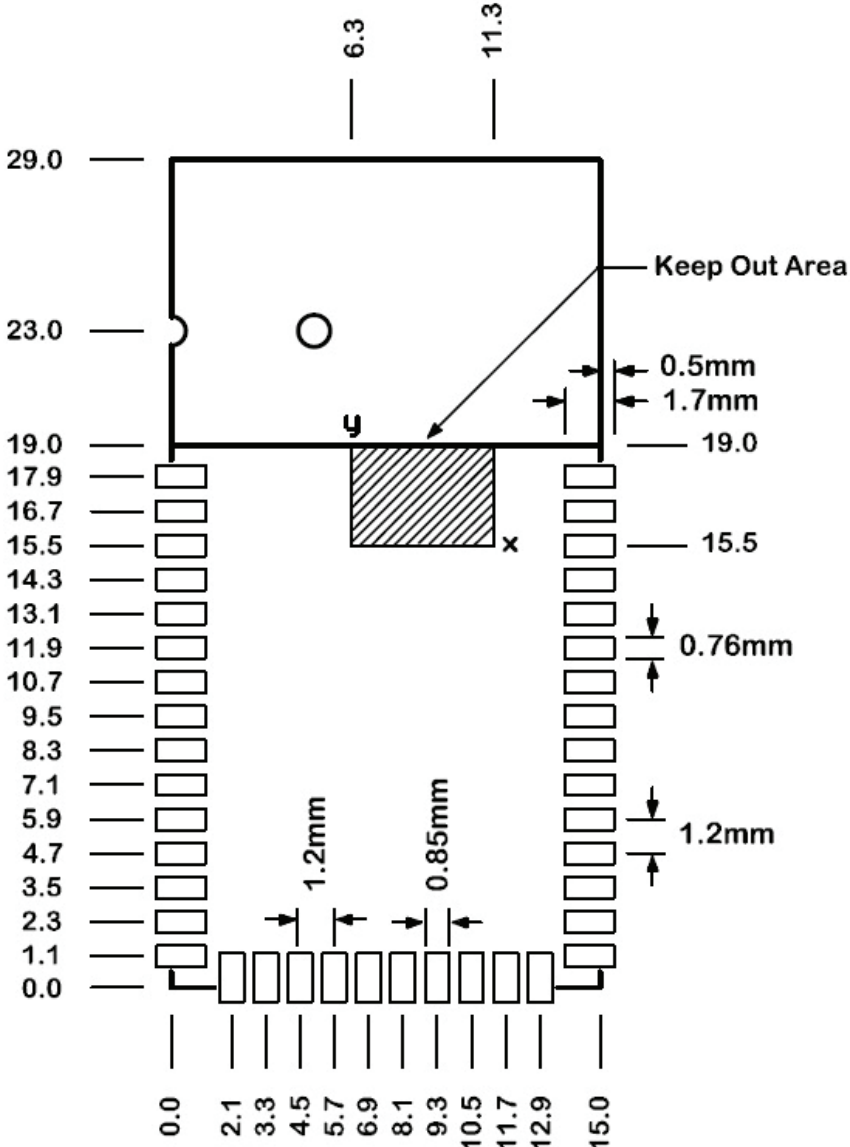

Note: The "Keep Out Area" is reserved for RF performance check.

7.2 REFLOW PROFILE

FIGURE 7-5: REFLOW PROFILE

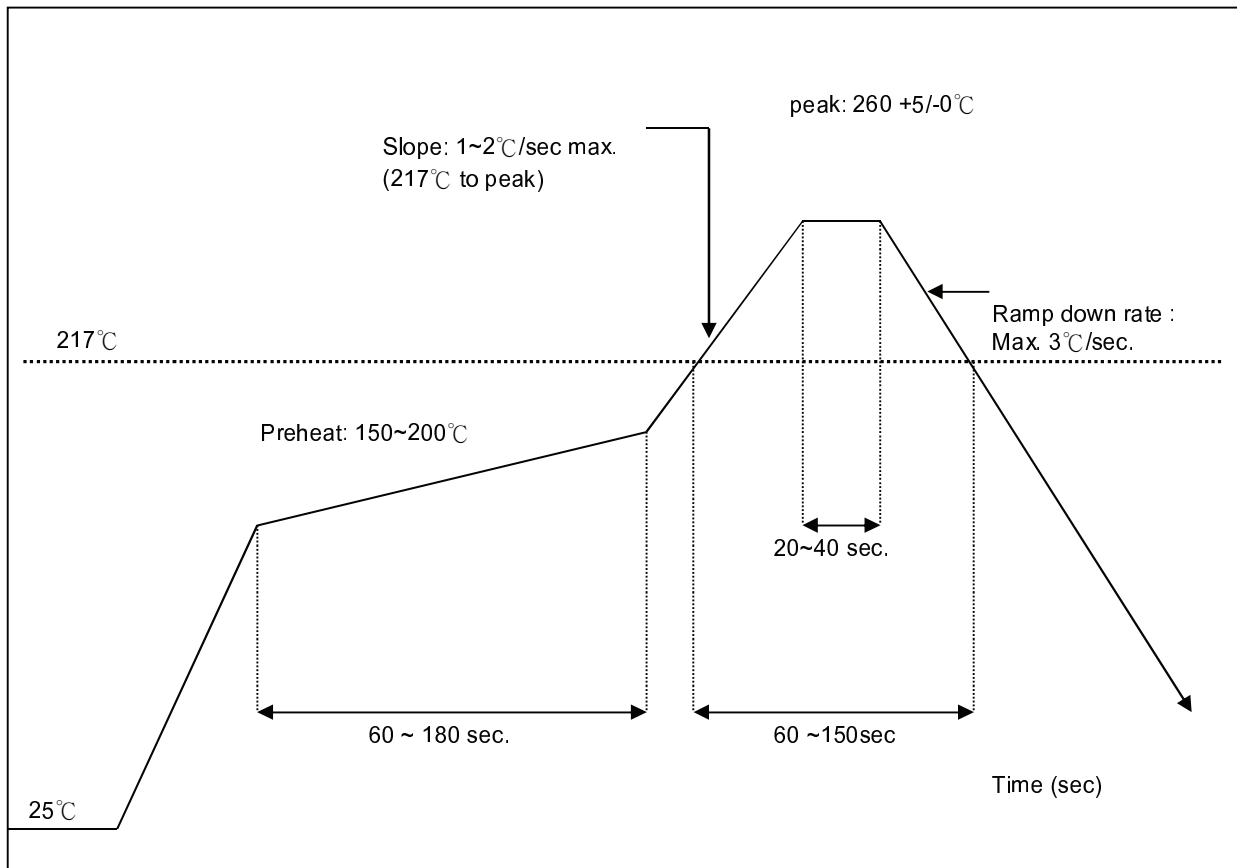

Soldering Recommendations

Stereo module was assembled using standard lead-free reflow profile IPC/JEDEC J-STD-020. The module can be soldered to the main PCB using standard leaded and lead-free solder reflow profiles. To avoid damaging of the module, the recommendations are listed as follows:

- Refer to Microchip Technology Application Note AN233 Solder Reflow Recommendation (DS00233) for the soldering reflow recommendations
- Do not exceed peak temperature (TP) of 250 degree C
- Refer to the solder paste data sheet for specific reflow profile recommendations
- Use no-clean flux solder paste
- Do not wash as moisture can be trapped under the shield
- Use only one flow. If the PCB requires multiple flows, apply the module on the final flow.

8.0 PACKAGING AND STORAGE INFORMATION

The module is packaged into trays (see following page) of sixty three (63) modules in a 7 x 9 format. These trays are then sealed into bags. Ten sealed bags are then placed in a box of 630 pieces with a dimension of 36 * 16 * 9.5 cm³.

The shelf life of each module in a sealed bag is 12 months at <40°C and <90% relative humidity. After a bag is opened, devices that will be subjected to reflow solder or other high temperature processes must be mounted within 168 hours (7 days) at factory conditions of <30°C and <60% relative humidity.

Stereo Module

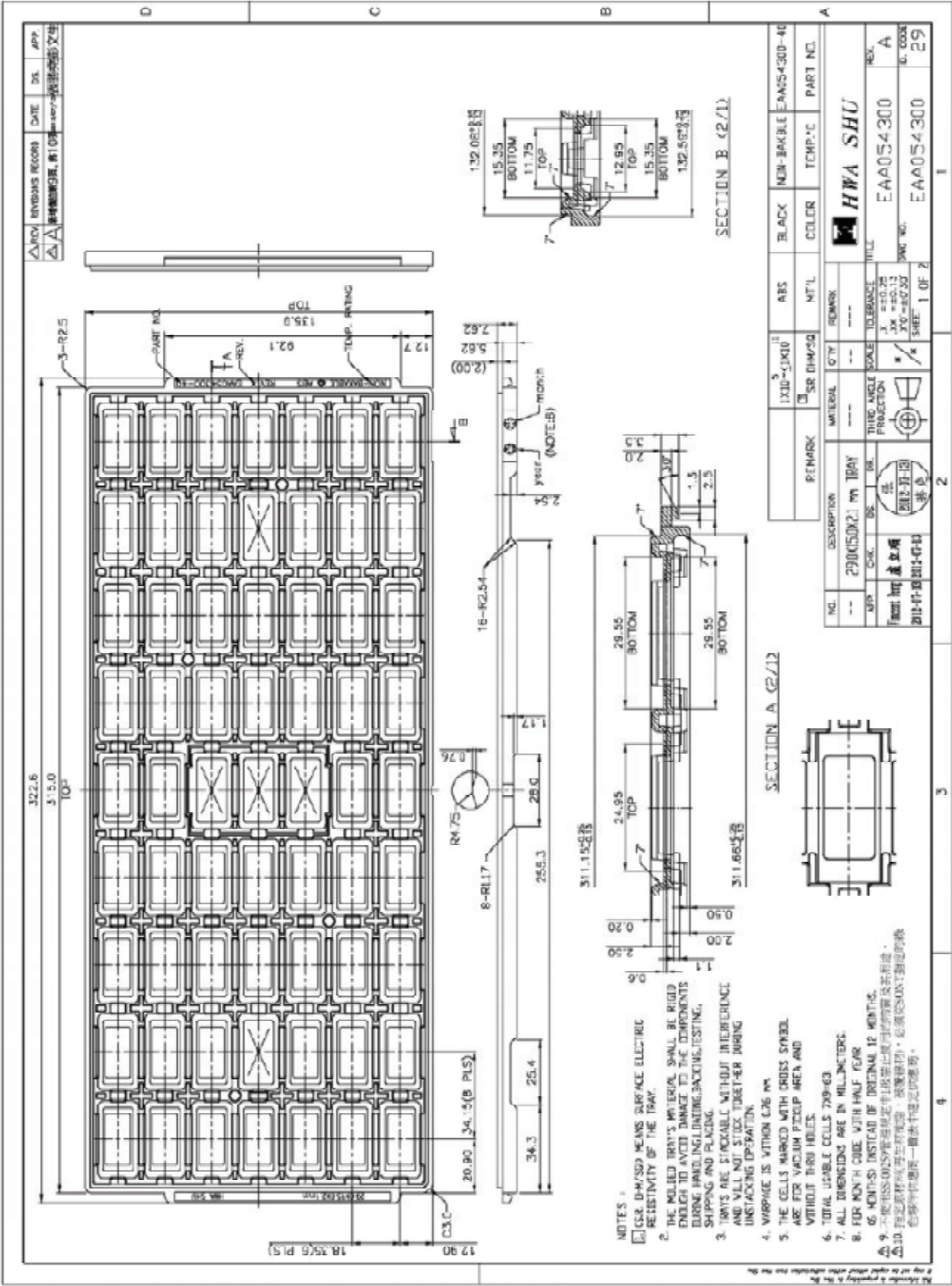

8.1 ORDERING INFORMATION

TABLE 5-1: Module Ordering Information

Part Number	Description
BM20SPKS1NBC	Bluetooth 4.1 BDR/EDR, Class 2 Surface Mount module with integrated antenna and shield
BM23SPKS1NB9	Bluetooth 4.1 BDR/EDR, Class 2 Surface Mount module with integrated antenna and shield

Note: The module can only be purchased through a Microchip representative.
Go to <http://www.microchip.com/> for current pricing and a list of distributors carrying Microchip products.

APPENDIX

A.1 United States

The module has received Federal Communications Commission (FCC) CFR47 Telecommunications, Part 15 Subpart C “Intentional Radiators” modular approval in accordance with Part 15.212 Modular Transmitter approval. Modular approval allows the end user to integrate the module into a finished product without obtaining subsequent and separate FCC approvals for intentional radiation, provided no changes or modifications are made to the module circuitry. Changes or modifications could void the user’s authority to operate the equipment. The end user must comply with all of the instructions provided by the Grantee, which indicate installation and/or operating conditions necessary for compliance.

The finished product is required to comply with all applicable FCC equipment authorizations regulations, requirements and equipment functions not associated with the transmitter module portion. For example, compliance must be demonstrated to regulations for other transmitter components within the host product; to requirements for unintentional radiators (Part 15 Subpart B “Unintentional Radiators”), such as digital devices, computer peripherals, radio receivers, etc.; and to additional authorization requirements for the non-transmitter functions on the transmitter module (i.e., Verification, or Declaration of Conformity) (e.g., transmitter modules may also contain digital logic functions) as appropriate.

A.1.1 LABELING AND USER INFORMATION REQUIREMENTS

The BM20/BM23 module has been labeled with its own FCC ID number, and if the FCC ID is not visible when the module is installed inside another device, then the outside of the finished product into which the module is installed must also display a label referring to the enclosed module. This exterior label can use wording as follows:

Contains Transmitter Module FCC ID:
A8TBM23SPKXYC2A or
Contains FCC ID: A8TBM23SPKXYC2A

This device complies with Part 15 of the FCC Rules. Operation is subject to the following two conditions: (1) this device may not cause harmful interference, and (2) this device must accept any interference received, including interference that may cause undesired operation

Contains Transmitter Module FCC ID:
A8TBM20SPKXYNBZ or
Contains FCC ID: A8TBM20SPKXYNBZ

This device complies with Part 15 of the FCC Rules. Operation is subject to the following two conditions: (1) this device may not cause harmful interference, and (2) this device must accept any interference received, including interference that may cause undesired operation

A user’s manual for the finished product should include the following statement:

Stereo Module

This equipment has been tested and found to comply with the limits for a Class B digital device, pursuant to part 15 of the FCC Rules. These limits are designed to provide reasonable protection against harmful interference in a residential installation. This equipment generates, uses and can radiate radio frequency energy, and if not installed and used in accordance with the instructions, may cause harmful interference to radio communications. However, there is no guarantee that interference will not occur in a particular installation. If this equipment does cause harmful interference to radio or television reception, which can be determined by turning the equipment off and on, the user is encouraged to try to correct the interference by one or more of the following measures:

- Reorient or relocate the receiving antenna.
- Increase the separation between the equipment and receiver.
- Connect the equipment into an outlet on a circuit different from that to which the receiver is connected.
- Consult the dealer or an experienced radio/TV technician for help.

Additional information on labeling and user information requirements for Part 15 devices can be found in KDB Publication 784748 available at the FCC Office of Engineering and Technology (OET) Laboratory Division Knowledge Database (KDB) <http://apps.fcc.gov/oetcf/kdb/index.cfm>.

3.1.2 RF EXPOSURE

All transmitters regulated by FCC must comply with RF exposure requirements. KDB 447498 General RF Exposure Guidance provides guidance in determining whether proposed or existing transmitting facilities, operations or devices comply with limits for human exposure to Radio Frequency (RF) fields adopted by the Federal Communications Commission (FCC).

From the FCC Grant: Output power listed is conducted. This grant is valid only when the module is sold to OEM integrators and must be installed by the OEM or OEM integrators. This transmitter is restricted for use with the specific antenna(s) tested in this application for Certification and must not be co-located or operating in conjunction with any other antenna or transmitters within a host device, except in accordance with FCC multi-transmitter product procedures.

3.1.3 HELPFUL WEB SITES

Federal Communications Commission (FCC): <http://www.fcc.gov>
FCC Office of Engineering and Technology (OET) Laboratory Division Knowledge Database (KDB): <http://apps.fcc.gov/oetcf/kdb/index.cfm>

A.2 Canada

The BM23 module has been certified for use in Canada under Industry Canada (IC) Radio Standards Specification (RSS) RSS-210 and RSS-Gen. Modular approval permits the installation of a module in a host device without the need to recertify the device.

A.2.1 LABELING AND USER INFORMATION REQUIREMENTS

Labeling Requirements for the Host Device (from Section 3.2.1, RSS-Gen, Issue 3, December 2010): The host device shall be properly labeled to identify the module within the host device.

The Industry Canada certification label of a module shall be clearly visible at all times when installed in

the host device, otherwise the host device must be labeled to display the Industry Canada certification

number of the module, preceded by the words “Contains transmitter module”, or the word “Contains”,

or similar wording expressing the same meaning, as follows:

Contains transmitter module IC: 12246A-BM23SPKXYC2

Contains transmitter module IC: 12246A-BM20SPKS1

User Manual Notice for License-Exempt Radio Apparatus (from Section 7.1.3 RSS-Gen, Issue 3, December 2010): User manuals for license-exempt radio apparatus shall contain the following or equivalent notice in a conspicuous location in the user manual or alternatively on the device or both:

This device complies with Industry Canada license-exempt RSS standard(s). Operation is subject to the following two conditions: (1) this device may not cause interference, and (2) this device must accept any interference, including interference that may cause undesired operation of the device.

Le présent appareil est conforme aux CNR d'Industrie Canada applicables aux appareils radio exempts de licence. L'exploitation est autorisée aux deux conditions suivantes: (1) l'appareil ne doit pas produire de brouillage, et (2) l'utilisateur de l'appareil doit accepter tout brouillage radioélectrique subi, même si le brouillage est susceptible d'en compromettre le fonctionnement.

Transmitter Antenna (from Section 7.1.2 RSS-Gen, Issue 3, December 2010): User manuals for transmitters shall display the following notice in a conspicuous location:

Stereo Module

Under Industry Canada regulations, this radio transmitter may only operate using an antenna of a type and maximum (or lesser) gain approved for the transmitter by Industry Canada. To reduce potential radio interference to other users, the antenna type and its gain should be so chosen that the equivalent isotropically radiated power (e.i.r.p.) is not more than that necessary for successful communication.

Conformément à la réglementation d'Industrie Canada, le présent émetteur radio peut fonctionner avec une antenne d'un type et d'un gain maximal (ou inférieur) approuvé pour l'émetteur par Industrie Canada. Dans le but de réduire les risques de brouillage radioélectrique à l'intention des autres utilisateurs, il faut choisir le type d'antenne et son gain de sorte que la puissance isotrope rayonnée équivalente (p.i.r.e.) ne dépasse pas l'intensité nécessaire à l'établissement d'une communication satisfaisante.

The above notice may be affixed to the device instead of displayed in the user manual. User manuals for transmitters equipped with detachable antennas shall also contain the following notice in a conspicuous location:

This radio transmitter (identify the device by certification number, or model number if Category II) has been approved by Industry Canada to operate with the antenna types listed below with the maximum permissible gain and required antenna impedance for each antenna type indicated. Antenna types not included in this list, having a gain greater than the maximum gain indicated for that type, are strictly prohibited for use with this device.

Conformément à la réglementation d'Industrie Canada, le présent émetteur radio peut fonctionner avec une antenne d'un type et d'un gain maximal (ou inférieur) approuvé pour l'émetteur par Industrie Canada. Dans le but de réduire les risques de brouillage radioélectrique à l'intention des autres utilisateurs, il faut choisir le type d'antenne et son gain de sorte que la puissance isotrope rayonnée équivalente (p.i.r.e.) ne dépasse pas l'intensité nécessaire à l'établissement d'une communication satisfaisante.

Immediately following the above notice, the manufacturer shall provide a list of all antenna types approved for use with the transmitter, indicating the maximum permissible antenna gain (in dBi) and required impedance for each.

A.2.2 OSURE

All transmitters regulated by IC must comply with RF exposure requirements listed in RSS-102 - Radio Frequency (RF) Exposure Compliance of Radiocommunication Apparatus (All Frequency Bands).

A.2.3 WEB SITES

Industry Canada: <http://www.ic.gc.ca/>

Stereo Module

A.3 Europe

The BM23 module is an R&TTE Directive assessed radio module that is CE marked and has been manufactured and tested with the intention of being integrated into a final product.

The BM23 module has been tested to R&TTE Directive 1999/5/EC Essential Requirements for Health and Safety (Article (3.1(a)), Electromagnetic Compatibility (EMC) (Article 3.1(b)), and Radio (Article 3.2) and are summarized in **Table 3-1: European Compliance Testing**. A Notified Body Opinion has also been issued.

The R&TTE Compliance Association provides guidance on modular devices in document **Technical Guidance Note 01** available at http://www.rtteca.com/html/download_area.htm.

Note: To maintain conformance to the testing listed in **Table A.3-1: European Compliance Testing**, the module shall be installed in accordance with the installation instructions in this data sheet and shall not be modified.

When integrating a radio module into a completed product the integrator becomes the manufacturer of the final product and is therefore responsible for demonstrating compliance of the final product with the essential requirements of the R&TTE Directive.

A.3.1 ABELING AND USER INFORMATION REQUIREMENTS

The label on the final product which contains the BM23 module must follow CE marking requirements. The R&TTE Compliance Association **Technical Guidance Note 01** provides guidance on final product CE marking.

A.3.2 ANTENNA REQUIREMENTS

From R&TTE Compliance Association document **Technical Guidance Note 01**:

Provided the integrator installing an assessed radio module with an integral or specific antenna and installed in conformance with the radio module manufacturer's installation instructions requires no further evaluation under Article 3.2 of the R&TTE Directive and does not require further involvement of an R&TTE Directive Notified Body for the final product. [Section 2.2.4]

The European Compliance Testing listed in **Table 3-1** was performed using the integral ceramic chip antenna.

TABLE A.3-1: EUROPEAN COMPLIANCE TESTING

Certificatio	Standards	Article	Laboratory	Report Number	Date
Safety	EN 60950-	(3.1(a))			
Health	EN 50371:2002-03				
EMC	EN 301 489-1 V1.8.1 (2008-04)	(3.1(b))			
	EN 301 489-17 V2.1.1 (2009-05)				
Radio	EN 300 328 V1.7.1 (2006-10)	(3.2)			
Notified Body					

A.3.3 HELPFUL WEB SITES

A document that can be used as a starting point in understanding the use of Short Range Devices (SRD) in Europe is the European Radio Communications Committee (ERC) Recommendation 70-03 E, which can be downloaded from the European Radio Communications Office (ERO) at: <http://www.ero.dk/>.

Additional helpful web sites are:

- Radio and Telecommunications Terminal Equipment (R&TTE):
http://ec.europa.eu/enterprise/rtte/index_en.htm
- European Conference of Postal and Telecommunications Administrations (CEPT):
<http://www.cept.org>
- European Telecommunications Standards Institute (ETSI):
<http://www.etsi.org>
- European Radio Communications Office (ERO):
<http://www.ero.dk>
- The Radio and Telecommunications Terminal Equipment Compliance Association (R&TTE CA):
<http://www.rtteca.com/>

A.4 Japan

The BM20/BM23 module has received type certification and is labeled with its own technical conformity mark and certification number as required to conform to the technical standards regulated by the Ministry of Internal Affairs and Communications (MIC) of Japan pursuant to the Radio Act of Japan.

Integration of this module into a final product does not require additional radio certification provided installation instructions are followed and no modifications of the module are allowed. Additional testing may be required:

- If the host product is subject to electrical appliance safety (for example, powered from an AC mains), the host product may require Product Safety Electrical Appliance and Material (PSE) testing. The integrator should contact their conformance laboratory to determine if this testing is required.
- There is an voluntary Electromagnetic Compatibility (EMC) test for the host product administered by VCCI: http://www.vcci.jp/vcci_e/index.html

A.4.1 LABELING AND USER INFORMATION REQUIREMENTS

The label on the final product which contains the BM20/BM23 module must follow Japan marking requirements. The integrator of the module should refer to the labeling requirements for Japan available at the Ministry of Internal Affairs and Communications (MIC) website.

The BM20/BM23 module is labeled with its own technical conformity mark and certification number. The final product in which this module is being used must have a label referring to the type certified module inside:

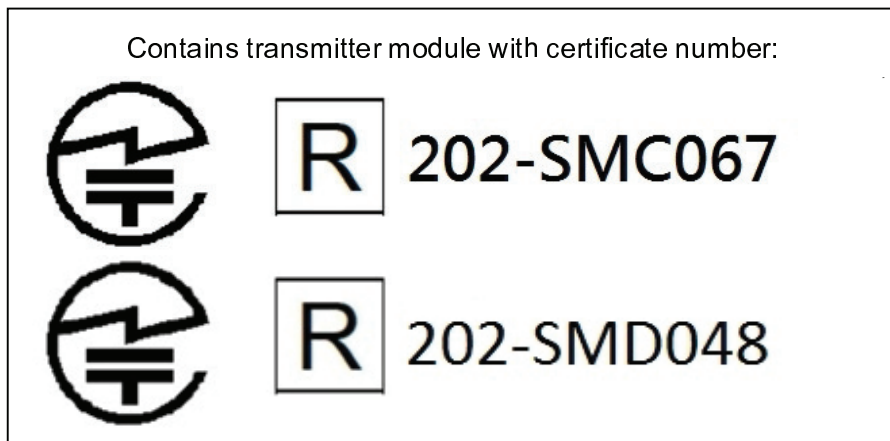

A.4.2 HELPFUL WEB SITES

Ministry of Internal Affairs and Communications (MIC):
<http://www.tele.soumu.go.jp/e/index.htm> Association of Radio Industries and Businesses (ARIB): <http://www.arib.or.jp/english/>

A.5 Korea

The BM23 module has received certification of conformity in accordance with the Radio Waves Act. Integration of this module into a final product does not require additional radio certification provided installation instructions are followed and no modifications of the module are allowed.

A.5.1 LABELING AND USER INFORMATION REQUIREMENTS

The label on the final product which contains the BM23 module must follow KC marking requirements.

The integrator of the module should refer to the labeling requirements for Korea available on the Korea

Communications Commission (KCC) website.

The BM23 module is labeled with its own KC mark. The final product requires the KC mark and certificate number of the module:

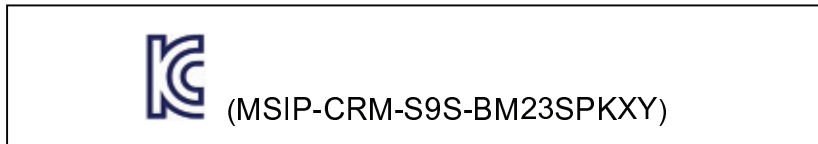

A.5.2 HELPFUL WEB SITES

Korea Communications Commission (KCC): <http://www.kcc.go.kr> National Radio Research Agency (RRA): <http://rra.go.kr>

A.6 Taiwan

The BM23 module has received compliance approval in accordance with the Telecommunications Act. Customers seeking to use the compliance approval in their product should contact Microchip Technology sales or distribution partners to obtain a Letter of Authority.

installation instructions are followed and no modifications of the module are allowed. Integration of this module into a final product does not require additional radio certification provided

A.6.1 LABELING AND USER INFORMATION REQUIREMENTS

The BM23 module is labeled with its own NCC mark and certificate number as below:



The user's manual should contain below warning (for RF device) in traditional Chinese:

注意!

依據 低功率電波輻射性電機管理辦法

第十二條 經型式認證合格之低功率射頻電機，非經許可，公司、商號或使用者均不得擅自變更頻率、加大功率或變更原設計之特性及功能。

第十四條 低功率射頻電機之使用不得影響飛航安全及干擾合法通信；經發現有干擾現象時，應立即停用，並改善至無干擾時方得繼續使用。前項合法通信，指依電信規定作業之無線電信。低功率射頻電機須忍受合法通信或工業、科學及醫療用電波輻射性電機設備之干擾。

A.6.2 HELPFUL WEB SITES

National Communications Commission (NCC): <http://www.ncc.gov.tw>



MICROCHIP

Worldwide Sales and Service

AMERICAS

Corporate Office
2355 West Chandler Blvd.
Chandler, AZ 85224-6199
Tel: 480-792-7200
Fax: 480-792-7277
Technical Support:
<http://www.microchip.com/support>
Web Address:
www.microchip.com

Atlanta
Duluth, GA
Tel: 678-957-9614
Fax: 678-957-1455

Austin, TX
Tel: 512-257-3370

Boston
Westborough, MA
Tel: 774-760-0087
Fax: 774-760-0088

Chicago
Itasca, IL
Tel: 630-285-0071
Fax: 630-285-0075

Cleveland
Independence, OH
Tel: 216-447-0464
Fax: 216-447-0643

Dallas
Addison, TX
Tel: 972-818-7423
Fax: 972-818-2924

Detroit
Novi, MI
Tel: 248-848-4000

Houston, TX
Tel: 281-894-5983

Indianapolis
Noblesville, IN
Tel: 317-773-8323
Fax: 317-773-5453

Los Angeles
Mission Viejo, CA
Tel: 949-462-9523
Fax: 949-462-9608

New York, NY
Tel: 631-435-6000

San Jose, CA
Tel: 408-735-9110

Canada - Toronto
Tel: 905-673-0699
Fax: 905-673-6509

ASIA/PACIFIC

Asia Pacific Office
Suites 3707-14, 37th Floor
Tower 6, The Gateway
Harbour City, Kowloon
Hong Kong
Tel: 852-2943-5100
Fax: 852-2401-3431

Australia - Sydney
Tel: 61-2-9868-6733
Fax: 61-2-9868-6755

China - Beijing
Tel: 86-10-8569-7000
Fax: 86-10-8528-2104

China - Chengdu
Tel: 86-28-8665-5511
Fax: 86-28-8665-7889

China - Chongqing
Tel: 86-23-8980-9588
Fax: 86-23-8980-9500

China - Hangzhou
Tel: 86-571-8792-8115
Fax: 86-571-8792-8116

China - Hong Kong SAR
Tel: 852-2943-5100
Fax: 852-2401-3431

China - Nanjing
Tel: 86-25-8473-2460
Fax: 86-25-8473-2470

China - Qingdao
Tel: 86-532-8502-7355
Fax: 86-532-8502-7205

China - Shanghai
Tel: 86-21-5407-5533
Fax: 86-21-5407-5066

China - Shenyang
Tel: 86-24-2334-2829
Fax: 86-24-2334-2393

China - Shenzhen
Tel: 86-755-8864-2200
Fax: 86-755-8203-1760

China - Wuhan
Tel: 86-27-5980-5300
Fax: 86-27-5980-5118

China - Xian
Tel: 86-29-8833-7252
Fax: 86-29-8833-7256

China - Xiamen
Tel: 86-592-2388138
Fax: 86-592-2388130

China - Zhuhai
Tel: 86-756-3210040
Fax: 86-756-3210049

ASIA/PACIFIC

India - Bangalore
Tel: 91-80-3090-4444
Fax: 91-80-3090-4123

India - New Delhi
Tel: 91-11-4160-8631
Fax: 91-11-4160-8632

India - Pune
Tel: 91-20-3019-1500

Japan - Osaka
Tel: 81-6-6152-7160
Fax: 81-6-6152-9310

Japan - Tokyo
Tel: 81-3-6880-3770
Fax: 81-3-6880-3771

Korea - Daegu
Tel: 82-53-744-4301
Fax: 82-53-744-4302

Korea - Seoul
Tel: 82-2-554-7200
Fax: 82-2-558-5932 or
82-2-558-5934

Malaysia - Kuala Lumpur
Tel: 60-3-6201-9857
Fax: 60-3-6201-9859

Malaysia - Penang
Tel: 60-4-227-8870
Fax: 60-4-227-4068

Philippines - Manila
Tel: 63-2-634-9065
Fax: 63-2-634-9069

Singapore
Tel: 65-6334-8870
Fax: 65-6334-8850

Taiwan - Hsin Chu
Tel: 886-3-5778-366
Fax: 886-3-5770-955

Taiwan - Kaohsiung
Tel: 886-7-213-7830

Taiwan - Taipei
Tel: 886-2-2508-8600
Fax: 886-2-2508-0102

Thailand - Bangkok
Tel: 66-2-694-1351
Fax: 66-2-694-1350

EUROPE

Austria - Wels
Tel: 43-7242-2244-39
Fax: 43-7242-2244-393

Denmark - Copenhagen
Tel: 45-4450-2828
Fax: 45-4485-2829

France - Paris
Tel: 33-1-69-53-63-20
Fax: 33-1-69-30-90-79

Germany - Dusseldorf
Tel: 49-2129-3766400

Germany - Munich
Tel: 49-89-627-144-0
Fax: 49-89-627-144-44

Germany - Pforzheim
Tel: 49-7231-424750

Italy - Milan
Tel: 39-0331-742611
Fax: 39-0331-466781

Italy - Venice
Tel: 39-049-7625286

Netherlands - Drunen
Tel: 31-416-690399
Fax: 31-416-690340

Poland - Warsaw
Tel: 48-22-3325737

Spain - Madrid
Tel: 34-91-708-08-90
Fax: 34-91-708-08-91

Sweden - Stockholm
Tel: 46-8-5090-4654

UK - Wokingham
Tel: 44-118-921-5800
Fax: 44-118-921-5820