

MICROCHIP ISSC Technologies Corp.
BM78SPPS5MC2,RN4678

Bluetooth® 4.0 Dual mode Module

Features:

- Bluetooth Classic (BR/EDR) and Low Energy (LE)
- Complete , Fully Certified, Embedded 2.4 GHz Bluetooth® Version 4.0 IC
- Bluetooth SIG Certified
- Transparent UART mode for seamless serial data over UART interface
- Easy to configure with Windows GUI or direct by MCU
- Firmware can be field upgradable via UART
- Compact surface mount module: 22 x 12 x 2.4 mm
- Castellated surface mount pads for easy and reliable host PCB mounting
- Perfect for Portable Battery Operated Devices
- Internal Battery Regulator Circuitry
- Worldwide regulatory certifications
- 1 LED and it has 16 steps Brightness.

Operational:

- Single operating voltage: 3.2V to 4.3V
- Temperature range: -20°C to 70°C Industrial
- Simple, UART interface
- Integrated crystal, internal voltage regulator, and matching circuitry
- Multiple I/O pins for control and status

RF/Analog:

- Frequency: 2.402 to 2.480 GHz
- Receive Sensitivity: -90 dBm (BR/EDR); -92 dBm (LE)
- Power Output: +2 dBm (typ.)

Data Throughput:

- 11k bps (BR/EDR)@ UART baud Rate is 115200 bps
- 8 Kbps (LE) UART baud Rate is 115200 bps

MAC/Baseband/Higher Layer:

- Secure AES128 encryption
- BTv3.0: GAP, SPP, SDP, RFCOMM and L2CAP
- BTv4.0: GAP, GATT, ATT, SMP and L2CAP.

FIGURE 1: BM78 TOP VIEW

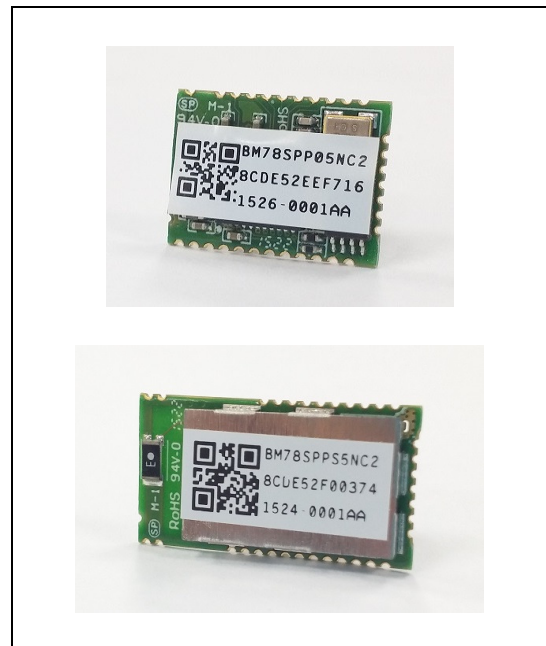

General Description:

The BM78 is a fully-certified Bluetooth® Version 4.0 (BR/EDR/LE) IC for designers who want to easily add dual mode Bluetooth® wireless capability to their products.

Delivering local connectivity for the Internet of Things (IoT), the IC bridges your product to Smart Phones and Tablets for convenient data transfer, control and access to cloud applications.

It supports GAP, SDP, SPP, and GATT profiles. Data is transferred over the Bluetooth link by sending/receiving data via transparent UART mode, making it easy to integrate with any processor or Microcontroller with a UART interface. Configuration is made easy using a Windows® based GUI or directly via UART

by a MCU

Applications:

- Mobile Point of Sales (mPOS)
- LED lighting (16 step)
- Wearables
- Digital Sports
- Fitness Devices
- Health Care/ Medical
- Automotive Accessories
- Home Automation
- Remote Control Toys

BM78SPPS5MC2 , RN4678

TO OUR VALUED CUSTOMERS

It is our intention to provide our valued customers with the best documentation possible to ensure successful use of your Microchip products. To this end, we will continue to improve our publications to better suit your needs. Our publications will be refined and enhanced as new volumes and updates are introduced.

If you have any questions or comments regarding this publication, please contact the Marketing Communications Department via E-mail at docerrors@microchip.com. We welcome your feedback.

Most Current Data Sheet

To obtain the most up-to-date version of this data sheet, please register at our Worldwide Web site at:

<http://www.microchip.com>

You can determine the version of a data sheet by examining its literature number found on the bottom outside corner of any page. The last character of the literature number is the version number, (e.g., DS30000000A is version A of document DS30000000).

Errata

An errata sheet, describing minor operational differences from the data sheet and recommended workarounds, may exist for current devices. As device/documentation issues become known to us, we will publish an errata sheet. The errata will specify the revision of silicon and revision of document to which it applies.

To determine if an errata sheet exists for a particular device, please check with one of the following:

- Microchip's Worldwide Web site; <http://www.microchip.com>
- Your local Microchip sales office (see last page)

When contacting a sales office, please specify which device, revision of silicon and data sheet (include literature number) you are using.

Customer Notification System

Register on our web site at www.microchip.com to receive the most current information on all of our products.

BM78SPPS5MC2 , RN4678

1.0 DEVICE OVERVIEW

The BM78 is a complete, fully certified, embedded 2.4 GHz Bluetooth® version 4.0 (BR/EDR/LE) wireless IC. It incorporates an on-board Bluetooth stack, cryptographic accelerator, power management subsystem, 2.4 GHz transceiver, and RF power amplifier (see **Figure 1**). With the BM78, designers can embed Bluetooth functionality rapidly into virtually any device.

The BM78 provides cost and time-to-market savings as a self-contained Bluetooth solution. The IC has been designed to provide integrators with a simple Bluetooth solution that features:

- Ease of integration and programming
- Vastly reduced development time
- Minimum system cost
- Interoperability with Bluetooth hosts
- Maximum value in a range of applications

The BM78 can independently maintain a low-power wireless connection. Low-power usage and flexible power management maximize the IC's lifetime in battery-operated devices. A wide operating temperature range allows use in indoor and outdoor environments (industrial temperature range).

The BM78 module comes in two varieties. The BM78SPPS3MC2 is a complete, fully regulatory certified module with integral ceramic chip antenna and shield. The BM78SPP03MC2 is a lower cost alternative with external antenna and no shield. The integrator is responsible for the antenna, antenna matching, and regulatory certifications.

The BM78 is a small, compact, surface mount module with castellated pads for easy and reliable host PCB mounting. The module is compatible with standard pick-and-place equipment.

TABLE 1-1: BM78 MODULE FAMILY TYPES

Device	Antenna	Shield	Regulatory Certifications
BM78SPPS5NC2	Integral ceramic chip	Yes	FCC, IC, CE, KCC, NCC, Japan
BM78SPP05NC2	External	No	NO

FIGURE 1: Block Diagram

BM78SPPS5MC2 , RN4678

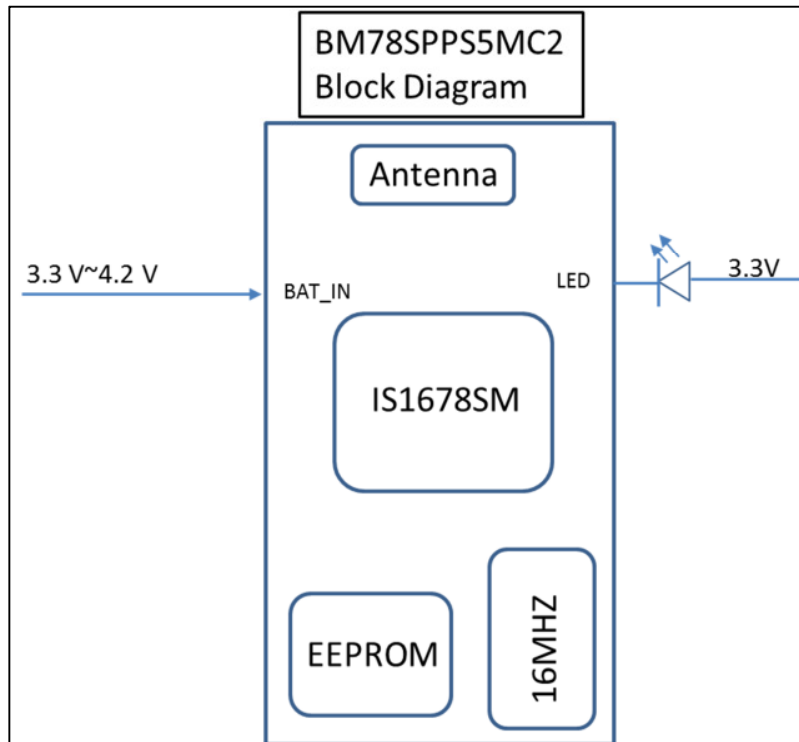
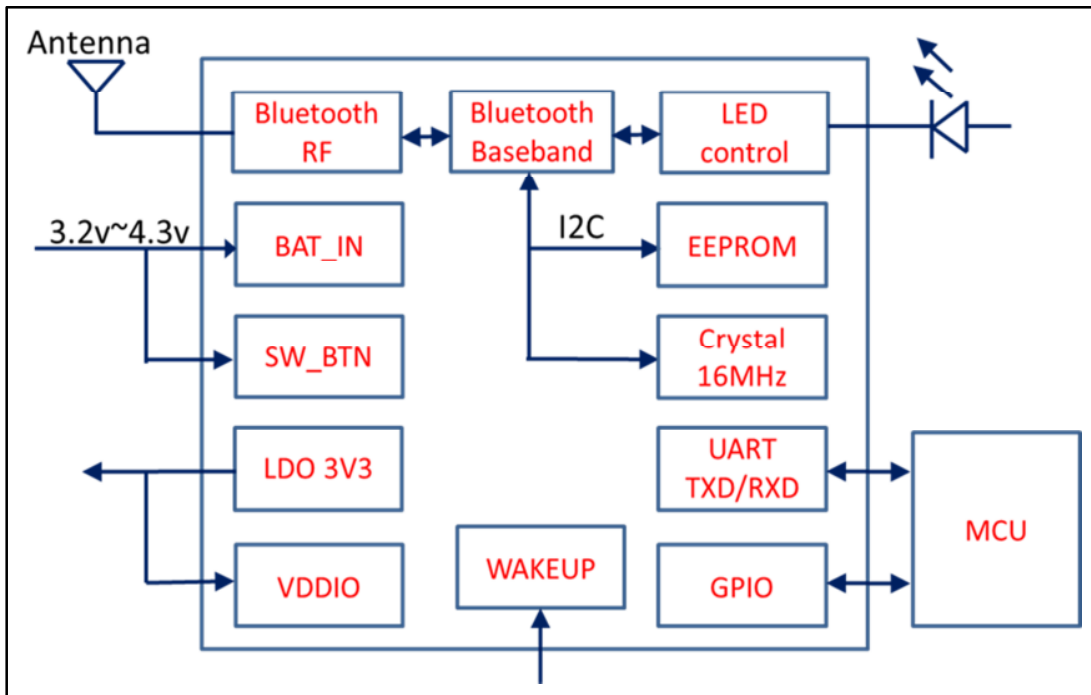

BM78SPPS5MC2 , RN4678

FIGURE 1-2: BM78SPPS5NC2 PIN DIAGRAM

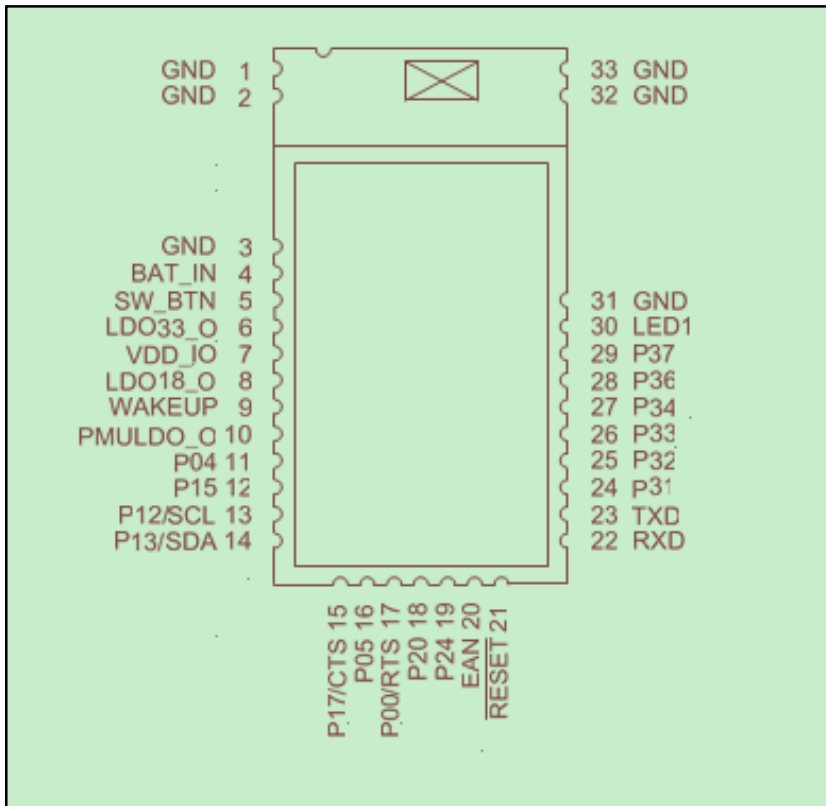
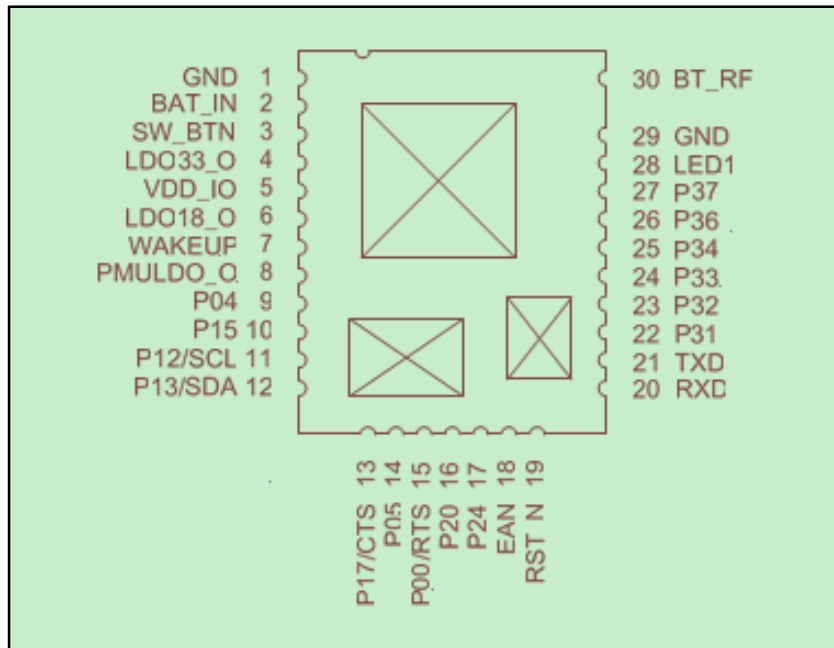

FIGURE 1-3: BM78SPP05NC2 PIN DIAGRAM



BM78SPPS5MC2 , RN4678

TABLE 1-1: PIN DESCRIPTION

5 pin	03 pin	Symbol	Type	Description
1	--	GND	Power	Ground reference
2	--	GND	Power	Ground reference
3	1	GND	Power	Ground reference
4	2	BAT_IN	Power	Battery Input. Main positive supply input. Connect to 10uF (X5R/X7R) capacitor.
5	3	SW_BTN	DI	Software Button H: Power On / L: Power Off
6	4	LDO33_O	Power	Internal 3.3V LDO regulator output. Connect to 10uF (X5R/X7R) capacitor.
7	5	VDD_IO	Power	I/O positive supply input. Ensure VDD_IO and MCU I/O voltages are compatible.
8	6	LDO18_O	Power	Internal 1.8V LDO regulator output. Connect to 10uF (X5R/X7R) capacitor.
9	7	WAKEUP	DI	Wakeup from shutdown mode (active low) (internal pull-up)
10	8	PMULDO_O	Power	Power management unit output. Connect to 1uF (X5R/X7R) capacitor.
11	9	P0_4	DO	UART_TX_IND: H: BM78 indicate UART data will be transmitted out after certain timing. (Setting by UI@ "MCU setting", default wait 5ms)*1 L: Otherwise. STATUS_IND_2: BM78 State indication , refer to P1_5
12	10	P1_5	DO	STATUS_IND: Bluetooth link status indication
13	11	P1_2/SCL	DO	I2C SCL (Do Not Connect)
14	12	P1_3/SDA	DIO	I2C SDA (Do Not Connect)
15	13	P1_7/CTS	DIO	Configurable Control or Indication pin or UART CTS (input)
16	14	P0_5	DIO	Configurable Control or Indication pin
17	15	P0_0/RTS	DIO	Configurable Control or Indication pin or UART RTS (output)
18	16	P2_0	DI	System configuration (internal pull-up)
19	17	P2_4	DI	System configuration (internal pull-up)
20	18	EAN	DI	System configuration (internal pull-down)
21	19	RST_N	DI	Module reset (active low) (internal pull-up) Apply a pulse of at least 63 ns.
22	20	RXD	DI	UART data input
23	21	TXD	DO	UART data output
24	22	P3_1	DIO	Configurable Control or Indication pin (when configured as input: internal pull-up)
25	23	P3_2	DIO	Configurable Control or Indication pin (when configured as input: internal pull-up)

BM78SPPS5MC2 , RN4678

26	24	P3_3	DIO	Configurable Control or Indication pin (when configured as input: internal pull-up)
27	25	P3_4	DIO	Configurable Control or Indication pin (when configured as input: internal pull-up)
28	26	P3_6	DIO	(Do Not Connect)
29	27	P3_7	DIO	Configurable Control or Indication pin (when configured as input: internal pull-up)
30	28	LED1	DO	Status LED
31	29	GND	Power	Ground reference
--	30	BT_RF	AIO	External antenna connection (50 ohm)
32	--	GND	Power	Ground reference
33	--	GND	Power	Ground reference

Note 1: Pin type abbreviation: A = Analog, D = Digital, I = Input, O = Output.

UI setting:

The screenshot displays the configuration interface for the device. The 'MCU Setting' section is highlighted with a blue box. The settings are as follows:

- Beacon Setting:**
 - Standby Timeout after Disconnection: 0x FF (0x01~0xFF, unit: 10.24s) Never deep power down
 - Discoverable under Standby Mode: Enable
- MCU Setting (highlighted):**
 - Wakeup External MCU Wait Time: 0x 01 (unit: 5 ms) total : 5 ms
- Misc.:**
 - Allow Into Low Power Mode Only In Standby: Disable
 - Switch Mode: Disable
 - SW Button Feature: Disable
- Version Control:**
 - EEPROM Footprint: BT5056SPP [16 characters]

Navigation buttons at the bottom include 'Previous', 'Next', and 'Finish'.

BM78SPPS5MC2 , RN4678

1.1 Power Tree

Figures 2-1 : Power Tree

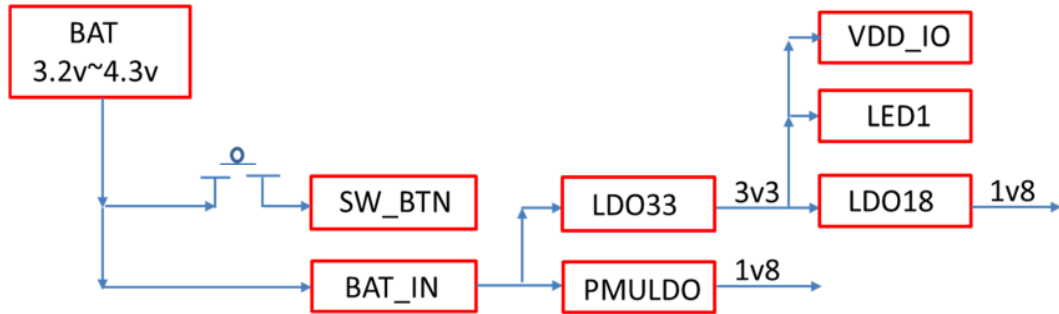

1.2 UART Interface

Figures 2-2 : Power and MCU interface examples.

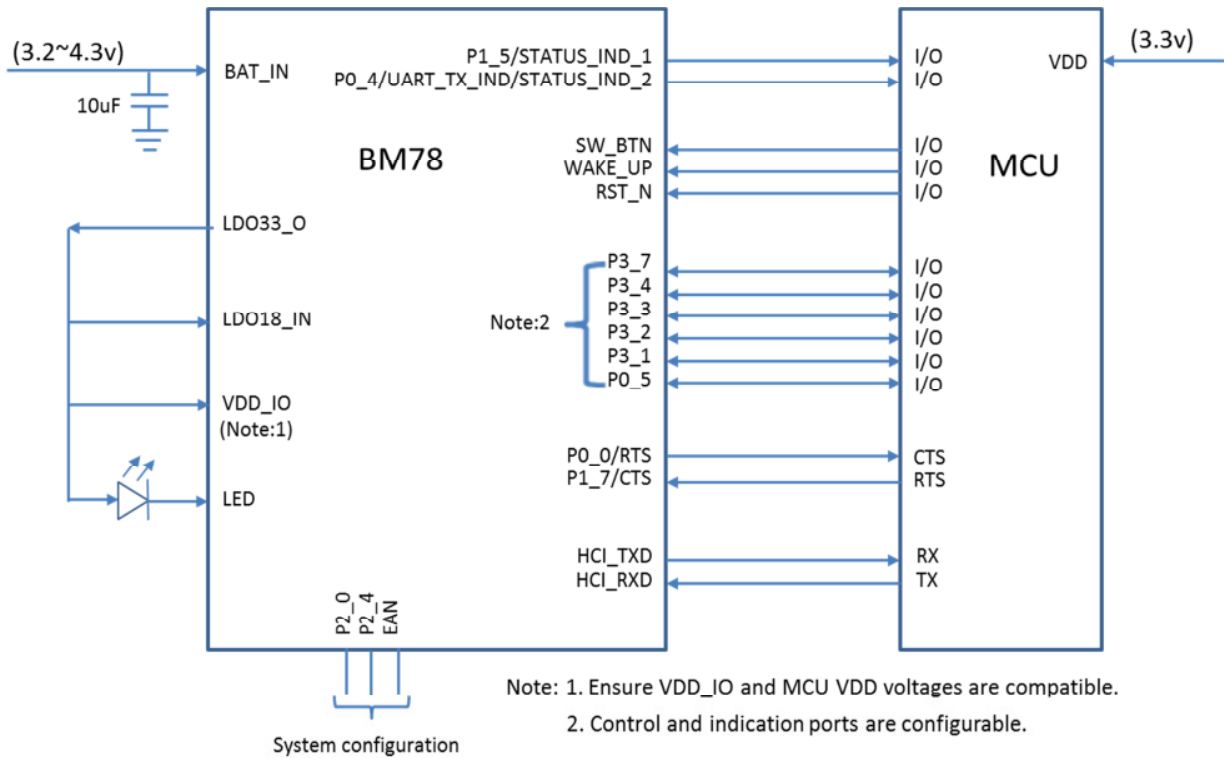
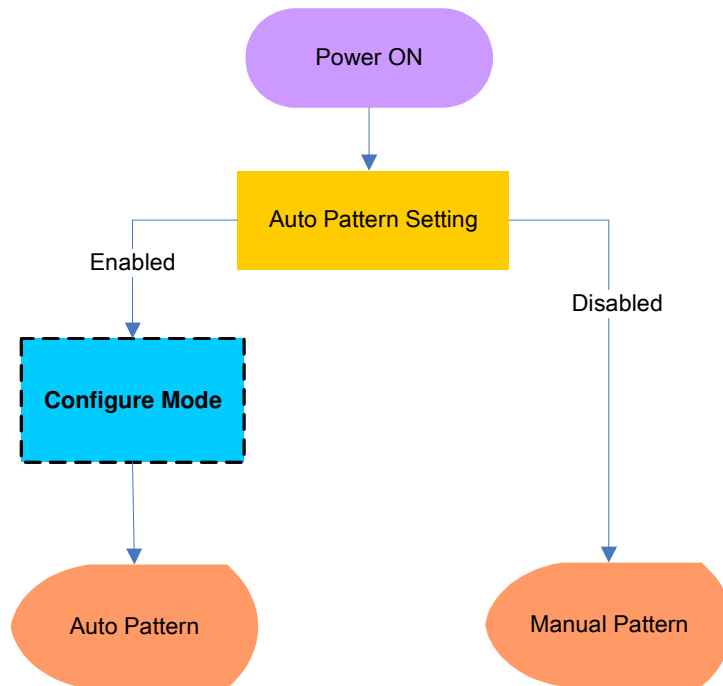

Figure 2-2 shows an example power scheme using a 3.3 volt to MCU VDD. Battery power is applied to BAT_IN pin. From the LDO33_O pin, voltage can be routed the VDD_IO pin and external circuitry including the MCU. This power scheme ensures that BM78 and MCU I/O voltages are compatible.

CAUTION: The internal 3.3volt LDO current source: 50mA maximum!!

2.0 Bluetooth behavior auto/manual pattern configuration



2.1 auto pattern

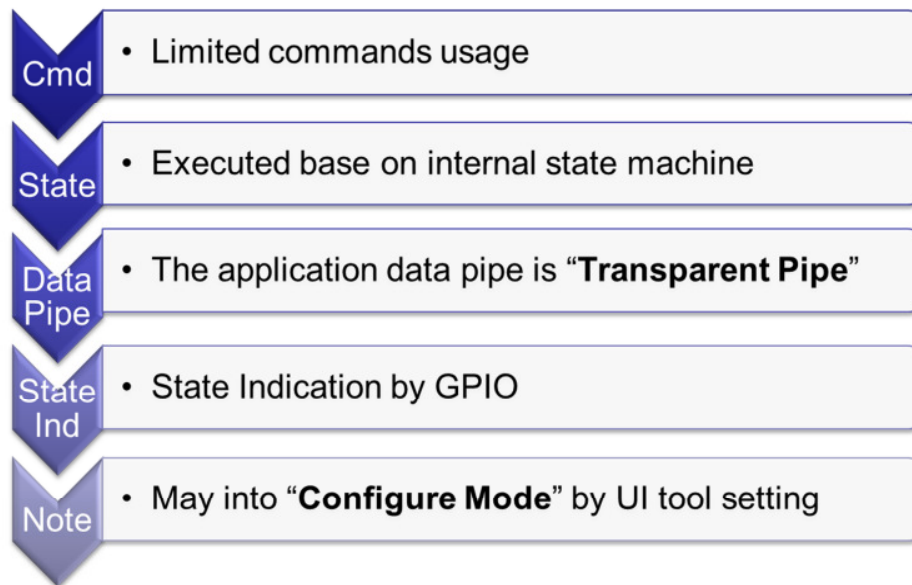

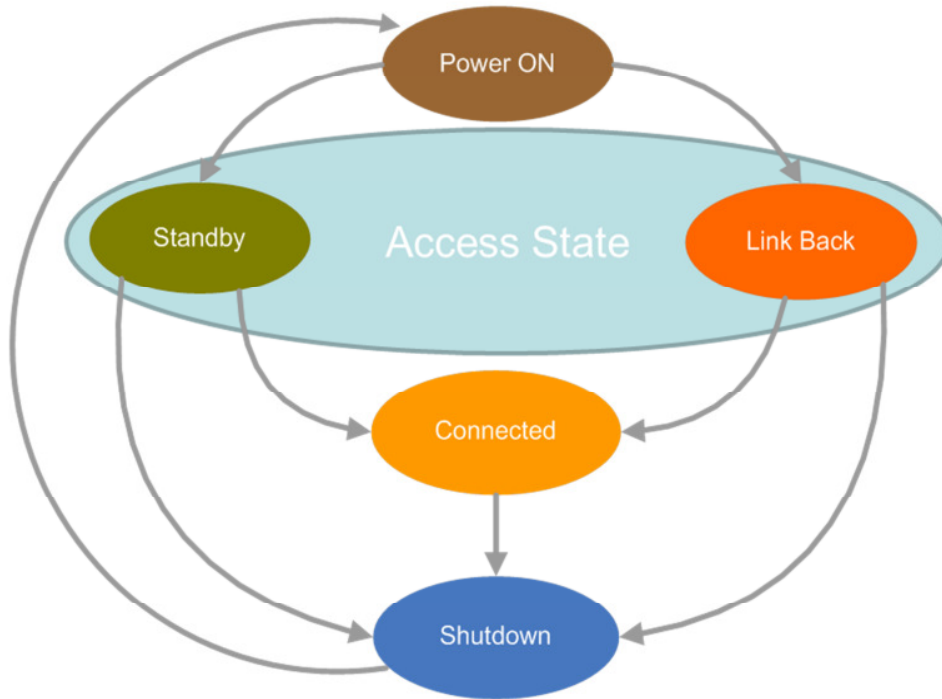

Access State	Configure mode
	Standby mode
	Link back mode
	Pairing Procedure
Link state	Connected mode
Shutdown state	Shutdown mode

2.2 Manual pattern

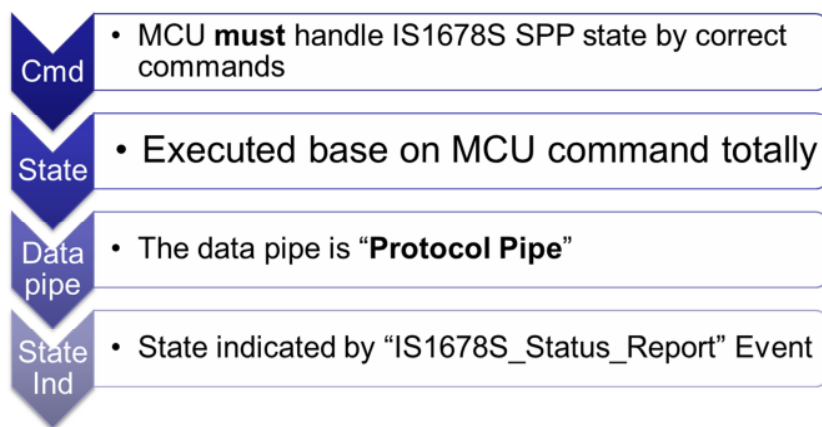

BM78SPPS5MC2 , RN4678

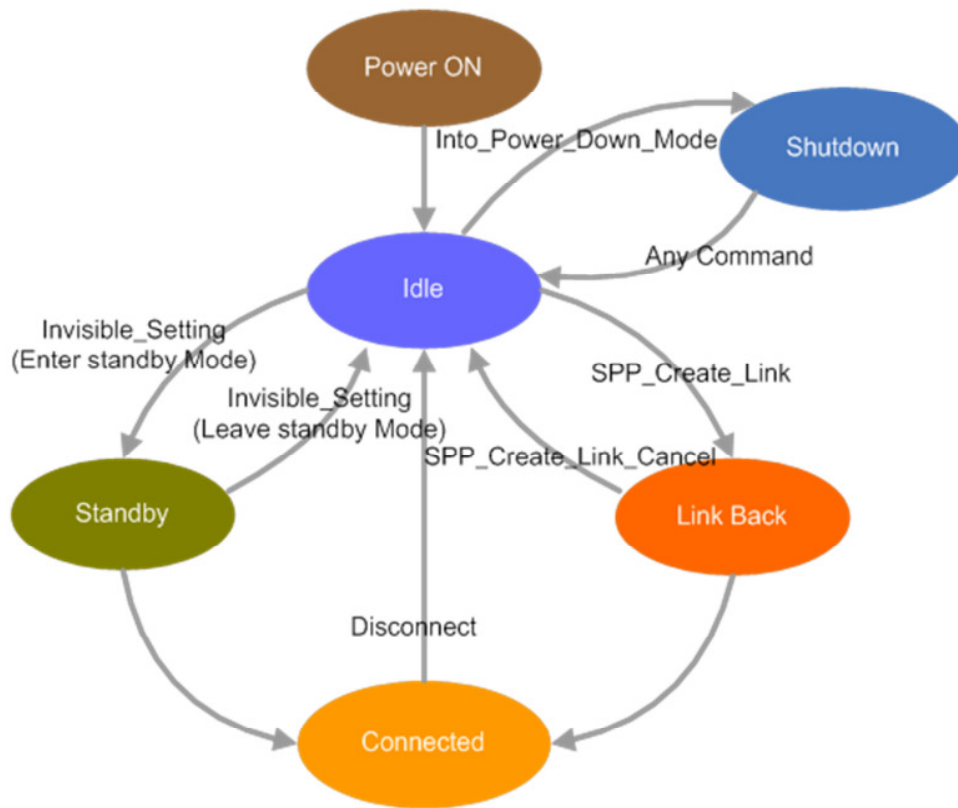

2.3 UI setting

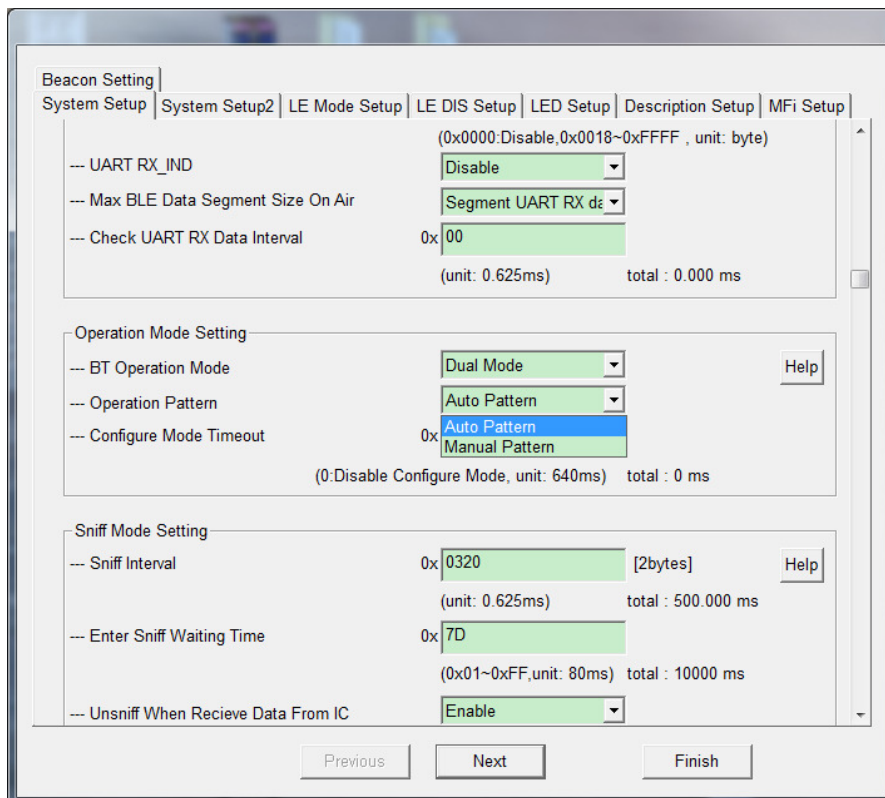

NOTE: Please reference ***“Application Note_IS1678S_Draft.docx”*** and ***“IS1678S Command Set v0 97 20140924.docx.”***

BM78SPPS5MC2 , RN4678

3.0 Control and Indication I/O Pins

I/O pins P0_0, P0_5, P1_7, P3_1, P3_2, P3_3, P3_4 and P3_7 are configurable control and indication I/O. Control signals are input to the BM78. Indication signals are output from the BM78.

Table 4-1 shows configurable I/O pin assignment to control and indication signals.

Note: that RTS can only be assigned to P0_0 and CTS is assigned to P1_7.

Configuring the BM78 can reference the *“Application Note_IS1678S_Draft.docx”* and *“IS1678S Command Set v0 97 20140924.docx.”*

TABLE 3-1: CONFIGURATION AND INDICATION I/O ASSIGNMENTS

	N/C	UART_RTS	UART_CTS	LOW_BATTERY_IND	RSSI_IND	GET WIFI INFO KEY	LINK_DROP_CONTROL (DISCONNECT)	UART_RX_IND	PAIRING_KEY	INQUIRY CONTROL	PROFILE_IND
P0_0		■	/								
P0_5	■	/	/								
P1_7		/	■								
P3_1		/	/							■	
P3_2		/	/				■				
P3_3		/	/					■			
P3_4		/	/						■		
P3_7		/	/	■							

BM78SPPS5MC2 , RN4678

3.1 UI setting

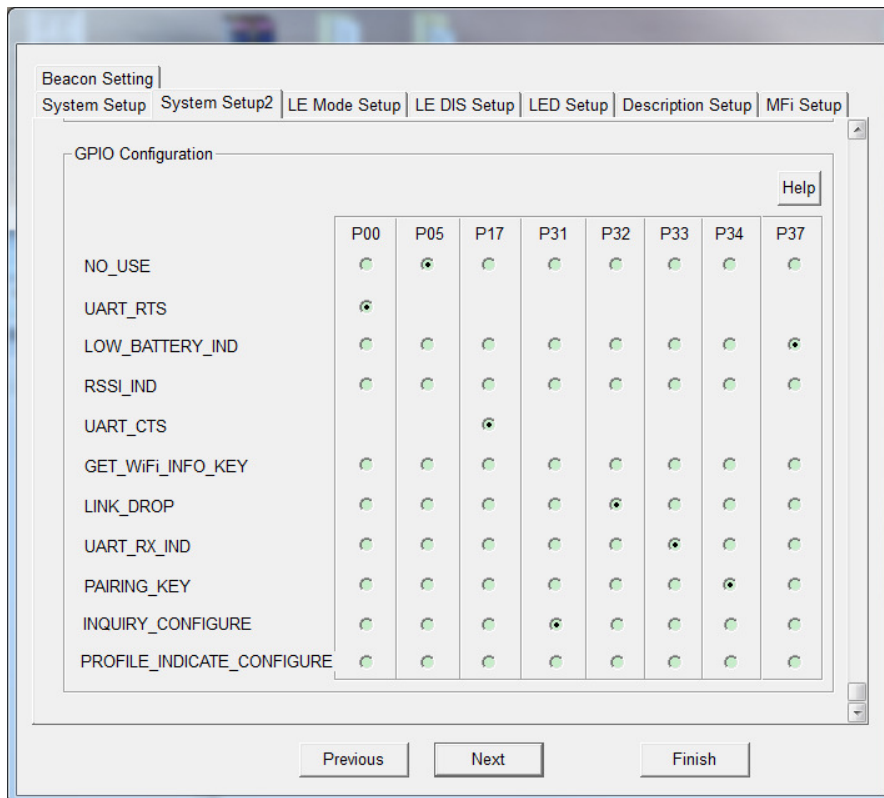

BM78SPPS5MC2 , RN4678

4.0 Status Indication I/O Pins

I/O pins P1_5 and P0_4 are Status Indicator 1 and 2 signals respectively. Together they provide status indication to the MCU as shown in **Table 4-1**.

TABLE 4-1: STATUS INDICATION

P1_5 /STATUS_IND_1	P0_4 /STATUS_IND_2	Indication
H	H	Power-on to setting default and Shutdown State. HH status should be stable for at least 500ms
H	L	Access state
L	H	Link state (UART data between being and stop transmitted)
L	L	Link state (UART data stop transmitted)

4.1 System Configuration

I/O pins P2_0, P2_4, and EAN place the BM78 into operation modes as shown in **Table 4-2**. P2_0, P2_4 and EAN each have internal pull-ups.

TABLE 4-2: SYSTEM CONFIGURATION SETTINGS

IC	P2_0	P2_4	EAN	Operational Mode
IS1678S	Low	High	High	Write EEPROM and test mode
	High	High	High	Normal operation / APP Mode

BM78SPPS5MC2 , RN4678

5.0 Software Button (SW_BTN)

The Software Button (SW_BTN) input pin powers the BM78 on (high) or off (low) in to S4 mode.

Figures 5-1 : SW_BTN Time (high) @APP mode

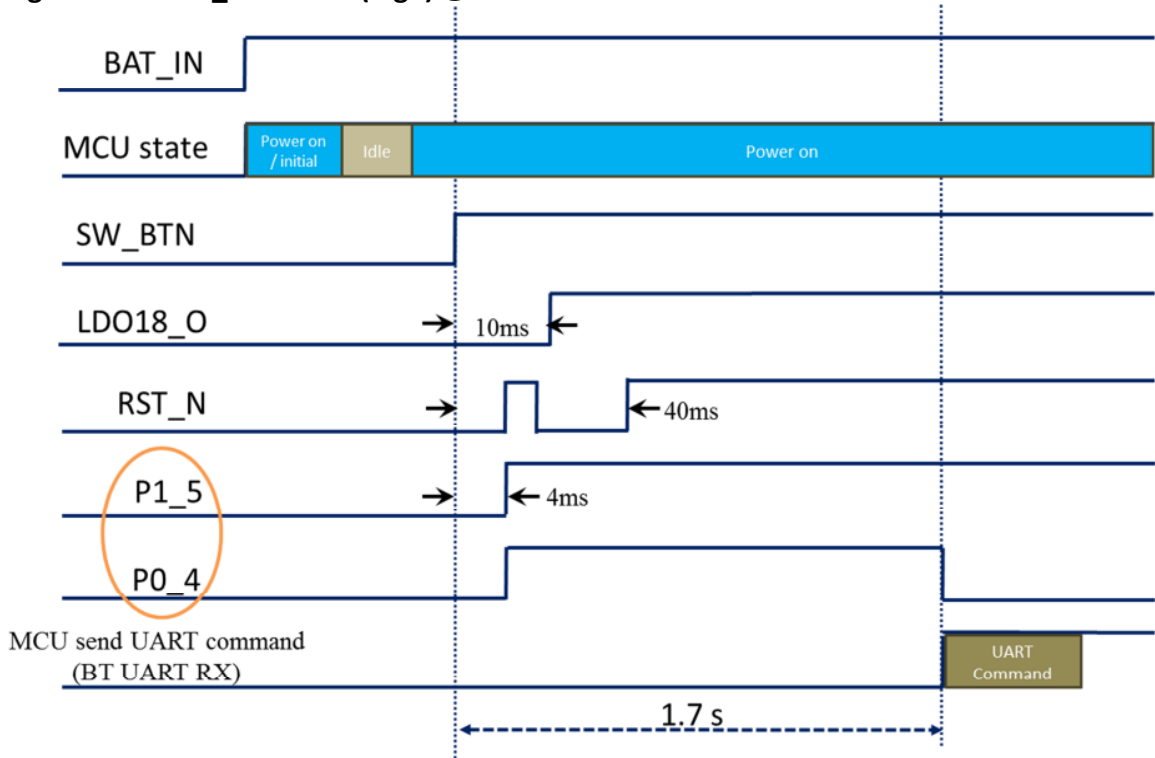

Note:

- A. P0_4/P1_5 state: Refer to table5-1
- B. Reset is floating.

Figures 5-2 : SW_BTN Time (low) at access states.

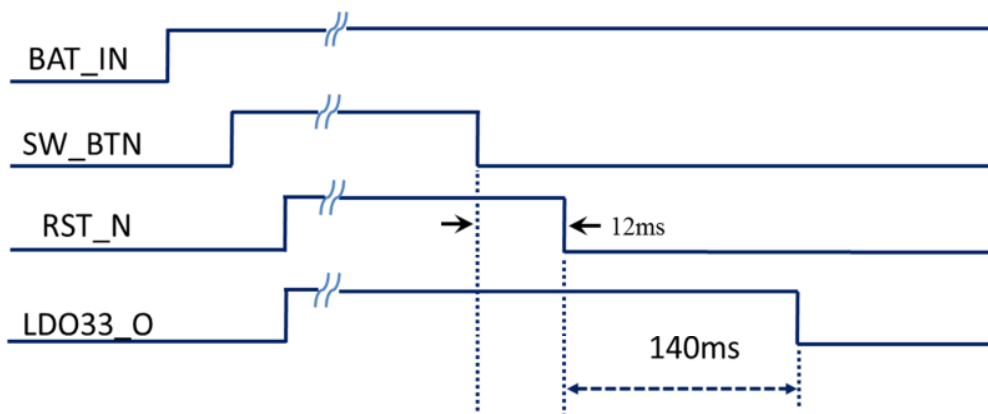

Note:

- A. SW_BTN pull low can't active on Shutdown State.
- B. Reset is floating.

Figures 5-3 : SW_BTN Time (low) at link states.

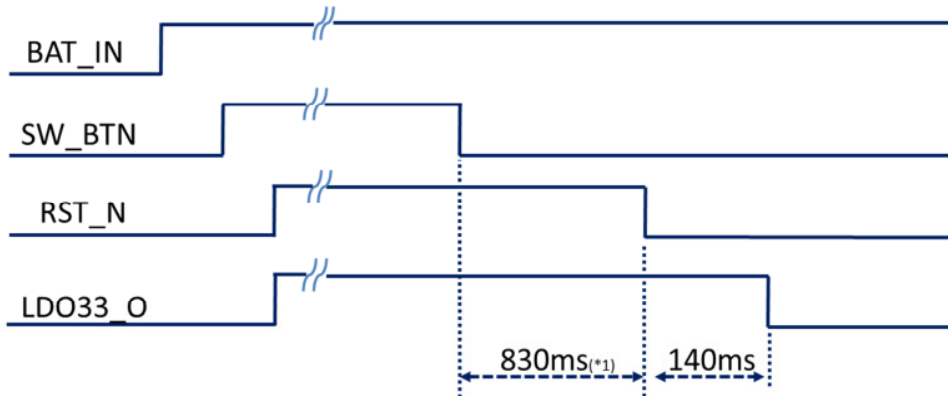

Note:

- C. *1: this time by iPhone LE mode disconnect time.
- D. SW_BTN pull low can't active on Shutdown State.
- E. Reset is floating.

6.0 WAKE UP

The Wake Up input pin wakes the BM78 from shutdown mode (active low).

Figures 6-1 : WAKE_UP Time at Shutdown State.

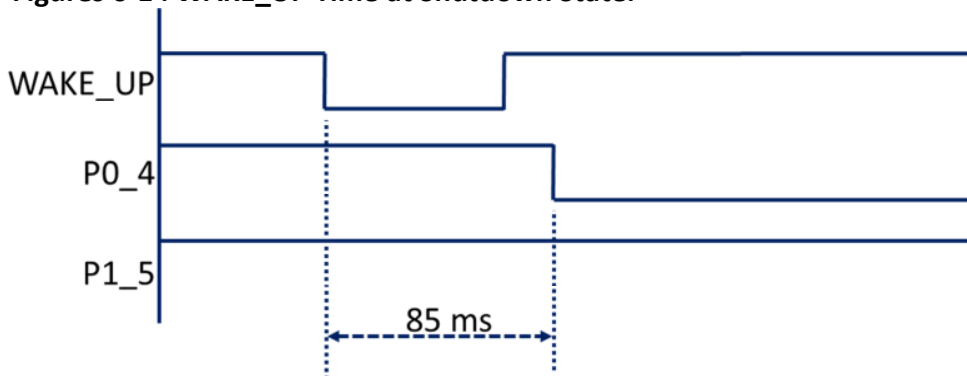

7.0 EXTERNAL RESET

A watchdog timer capable of reset the chip. It has an integrated Power-On Reset (POR) circuit that resets all circuits to a known power-on state. This action can also be driven by an external reset signal that can be used to externally control the device, forcing it into a power-on reset state. The RST signal input is active low and no connection is required in most applications.

Figures 7 -1 : Reset Time at Shutdown State.

BM78SPPS5MC2 , RN4678

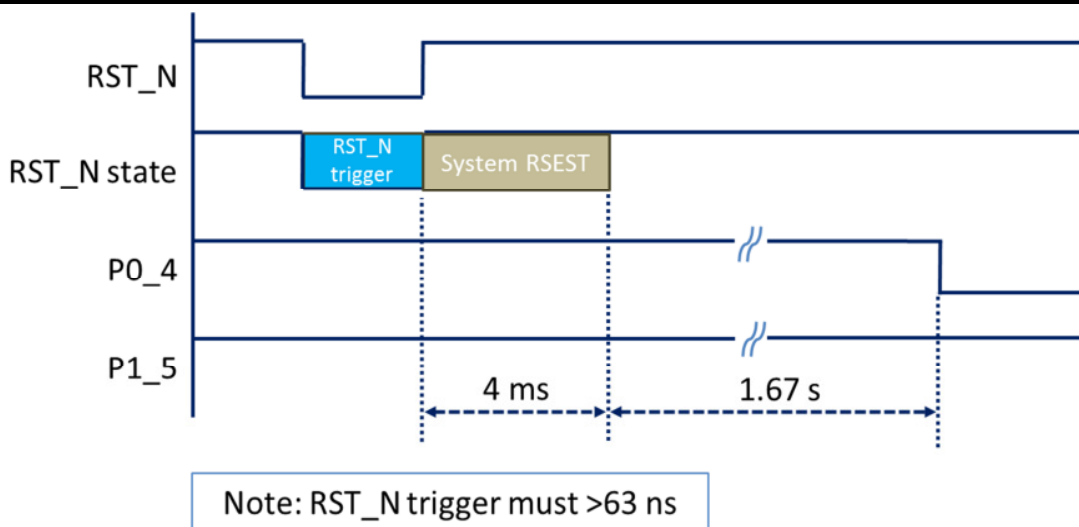

Note:

- Auto pattern can use external reset.
- Manual pattern can use external reset and reset command.

8.0 LED DRIVER

There are one dedicate LED drivers to control the LEDs. The LED can be connected directly with BM78. The LED max current is 4 mA and it has 16 steps to trim Brightness.

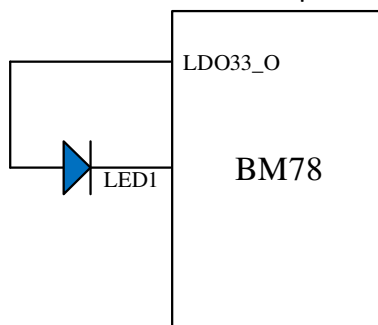

The status LED (LED1) indicates:

- Standby
- Link Back
- Low Battery
- Inquiry
- Link
- Page

Each indication is a configurable flashing sequence. LED brightness can also be configured.

9.0 MEMORY

A synchronous single port RAM interface is used. There are sufficient ROM and RAM to fulfill the requirement of processor. A register bank, a dedicated single port memory and a flash memory are connected to the processor bus. The processor coordinates all the link control procedures and data movement using a set of pointers registers.

BM78SPPS5MC2 , RN4678



BM78SPPS5MC2 , RN4678

10.0 Throughput

The BM78 UART pins TXD and RXD connect to the UART pins of the host MCU. It is highly recommended to use hardware flow control pins RTS and CTS. The BM78 hardware flow control is disabled by default and must be configured to enable. The UART Baud is configurable. The available signal rates are listed in **Table 10-1**.

TABLE 10-1: UART BAUD

Baud	Crystal Frequency (MHz)	Actual Baud	Error Rate (%)
921600	16	941176	2.12
460800	16	457143	-0.79
307200	16	307692	0.16
230400	16	231884	0.64
115200	16	117647	2.1
57600	16	57145	-0.97
38400	16	38462	0.16
28800	16	28623	-0.62
19200	16	19231	0.16
14400	16	14480	0.55
9600	16	9615	0.16
4800	16	4808	0.16
2400	16	2399	-0.03

TABLE 10-2: APP mode Throughput report

BR/EDR mode iPad mini (Wi-Fi disable){iOS 7.0.4 (11B554a)}				
921600 bps	echo Tx	echo Rx	Tx	Rx
Burst Throughput(byte/s)	14384.46	9845.31	14521.5	14333.3
Normal Throughput(byte/s)	8437.462	8375.28	6674.11	14399.4

BR/EDR mode iPad mini (Wi-Fi disable){iOS 7.0.4 (11B554a)}				
115200 bps	echo Tx	echo Rx	Tx	Rx
Burst Throughput(byte/s)	11080.55	9284.37	11640.3	11134.8
Normal Throughput(byte/s)	6248.758	6211.69	11513	11158.4

BR/EDR mode Android Samsung Note3/Android 4.3				
921600 bps	echo Tx	echo Rx	Tx	Rx
Normal Throughput(byte/s)	9727.704	9041.34	17030.1	10233.6

BM78SPPS5MC2 , RN4678

BR/EDR mode	Android Samsung Note3/Android 4.3			
115200 bps	echo Tx	echo Rx	Tx	Rx
Normal Throughput(byte/s)	11312.2	10548.5	9842.5	11436.4

LE mode	iPad mini (Wi-Fi disable){iOS 7.0.4 (11B554a)}		
115200 bps	TX	RX (response)	Rx (Reliable Burst Transmit)
Normal Throughput(byte/s)	7935.2	3337.3	7082.1

LE mode	iPad mini (Wi-Fi disable){iOS 7.0.4 (11B554a)}		
921600 bps	TX	RX (response)	Rx (Reliable Burst Transmit)
Normal Throughput(byte/s)	8063.2	3384.5	6839.9



BM78SPPS5MC2 , RN4678

11.0 Mounting Details

The BM78 SPPS5MC2 physical dimensions are shown in Figure 11-1, recommended host PCB footprint in Figure 11-2, and mounting suggestion in Figure 11-3. There should not be top copper layer near the test pin area shown in Figure 11-2. When laying out the host PCB, the areas under the antenna should not contain any top, inner layer, or bottom copper as shown in Figure 11-3. A low-impedance ground plane will ensure best radio performance (best range, lowest noise). Figure 11-3 shows a minimum ground plane area to the left and right of the module for best antenna performance. The ground plane can be extended beyond the minimum recommended as need for host PCB EMC noise reduction. For best range performance, keep all external metal away from the ceramic chip antenna at least 31 mm.

The BM78SPP03MC2 physical dimensions are shown in Figure 11-4, recommended host PCB footprint in Figure 11-5, and mounting suggestion in Figure 11-6. It is highly recommended to layout the host PCB as suggested in Figure 11-6. A low-impedance ground plane will ensure best radio performance (best range, lowest noise). Pin 30 (BT_RF) is a 50 ohm connection to an external antenna connector, PCB trace antenna, or component (ceramic chip) antenna through a host PCB 50 ohm micro-strip trace. This trace can be extended to include passive parts for antenna attenuation padding, impedance matching, or to provide test posts. It is recommended that the micro-strip trace be as short as possible for minimum loss and best impedance matching. If the micro-strip trace is longer, it should be a 50 ohm impedance. Figure 11-6 shows an example connection to U.FL connector.

Soldering Recommendations

The BM78 wireless module was assembled using standard lead-free reflow profile IPC/JEDEC J-STD-020. The module can be soldered to the host PCB using standard leaded and lead-free solder reflow profiles. To avoid damaging the module, the following recommendations are given:

- Microchip Technology Application Note AN233 Solder Reflow Recommendation (DS00233) provides solder reflow recommendations
- Do not exceed peak temperature (T_p) of 250 deg C
- Refer to the solder paste data sheet for specific reflow profile recommendations
- Use no-clean flux solder paste
- Do not wash as moisture can be trapped under the shield
- Use only one flow. If the PCB requires multiple flows, apply the module on the final flow.

BM78SPPS5MC2 , RN4678

FIGURE 11-1: BM78SPPS5NCS MODULE DIMENSIONS

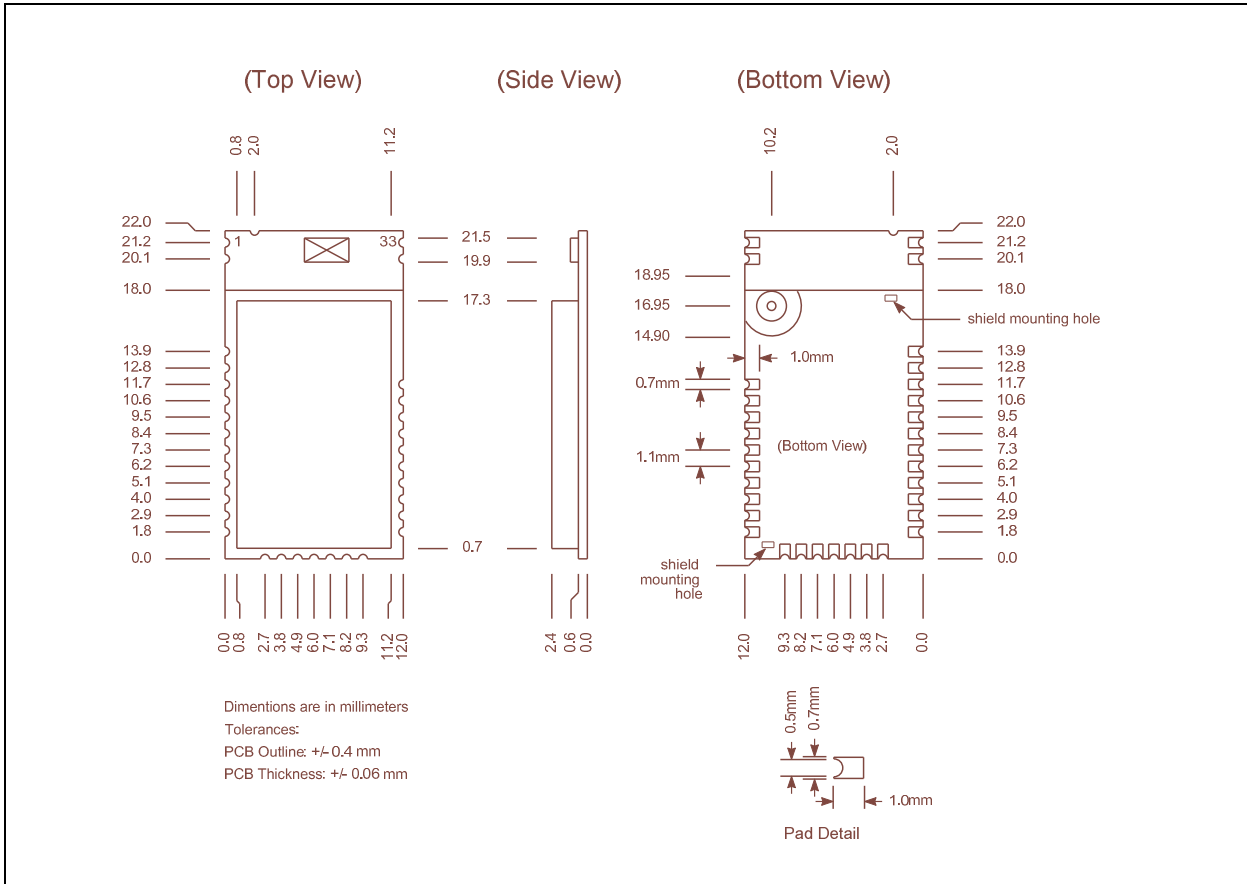
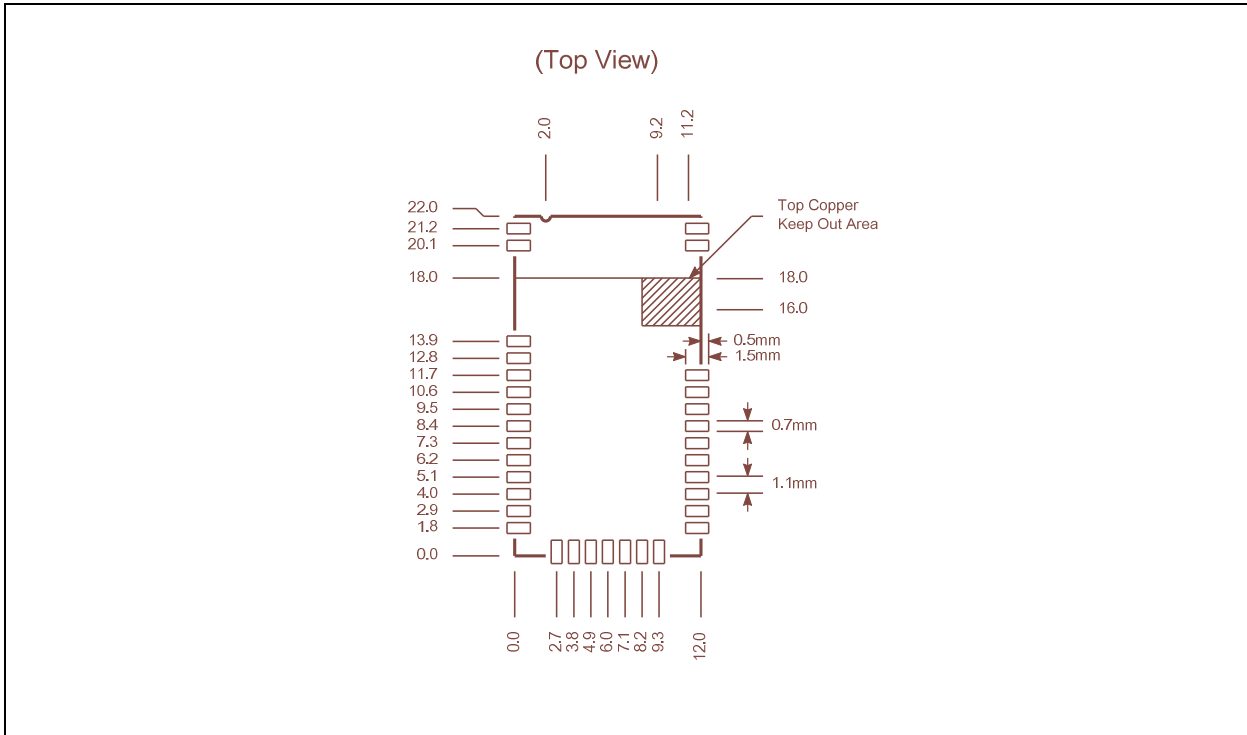
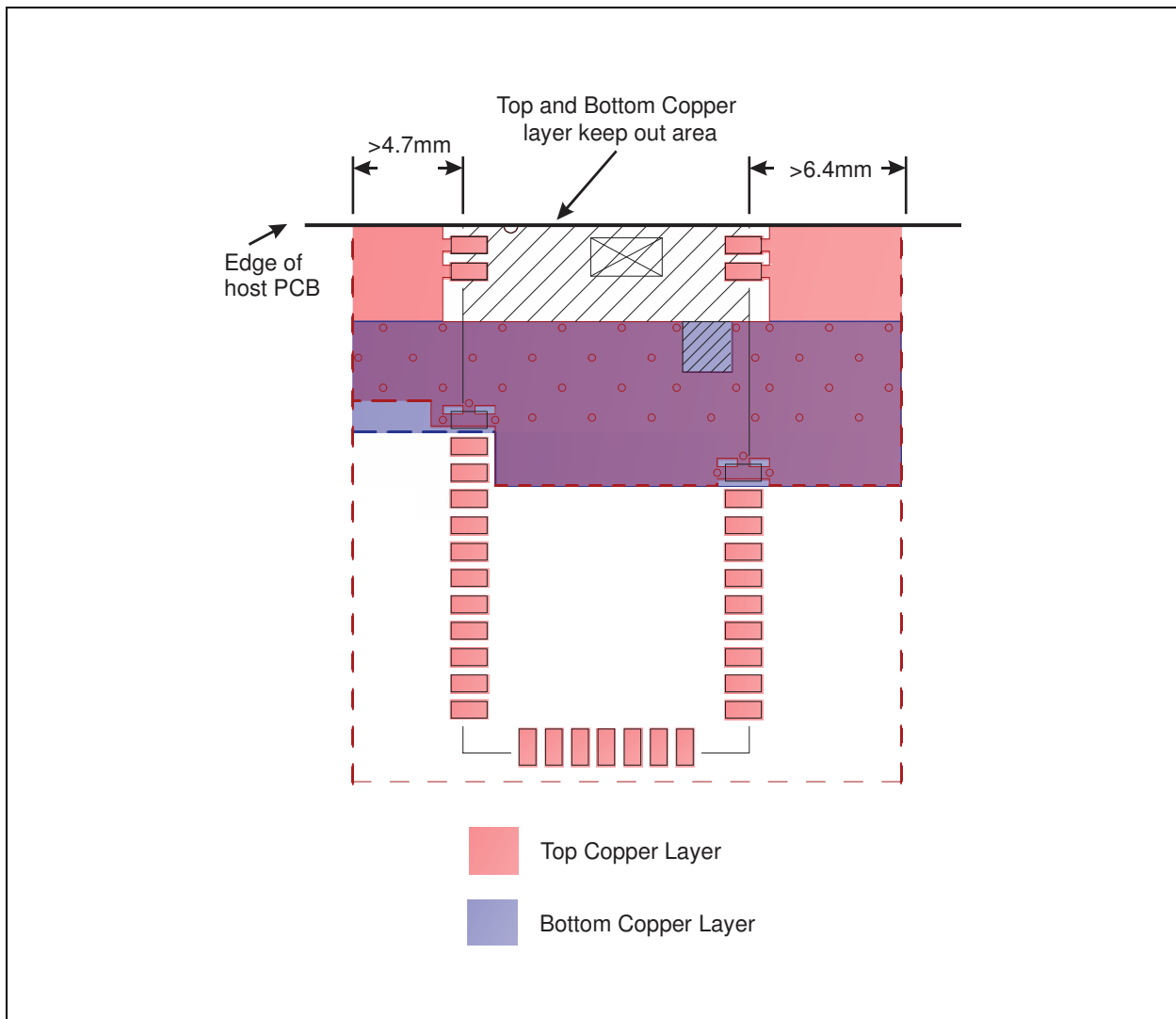

FIGURE 11-2: BM78SPPS5NC2 RECOMMENDED PCB FOOTPRINT



BM78SPPS5MC2 , RN4678

FIGURE 11-3: BM78SPPS5NCS HOST PCB MOUNTING SUGGESTION



BM78SPPS5MC2 , RN4678

FIGURE 11-4: BM78SPP05NCS MODULE DIMENSIONS

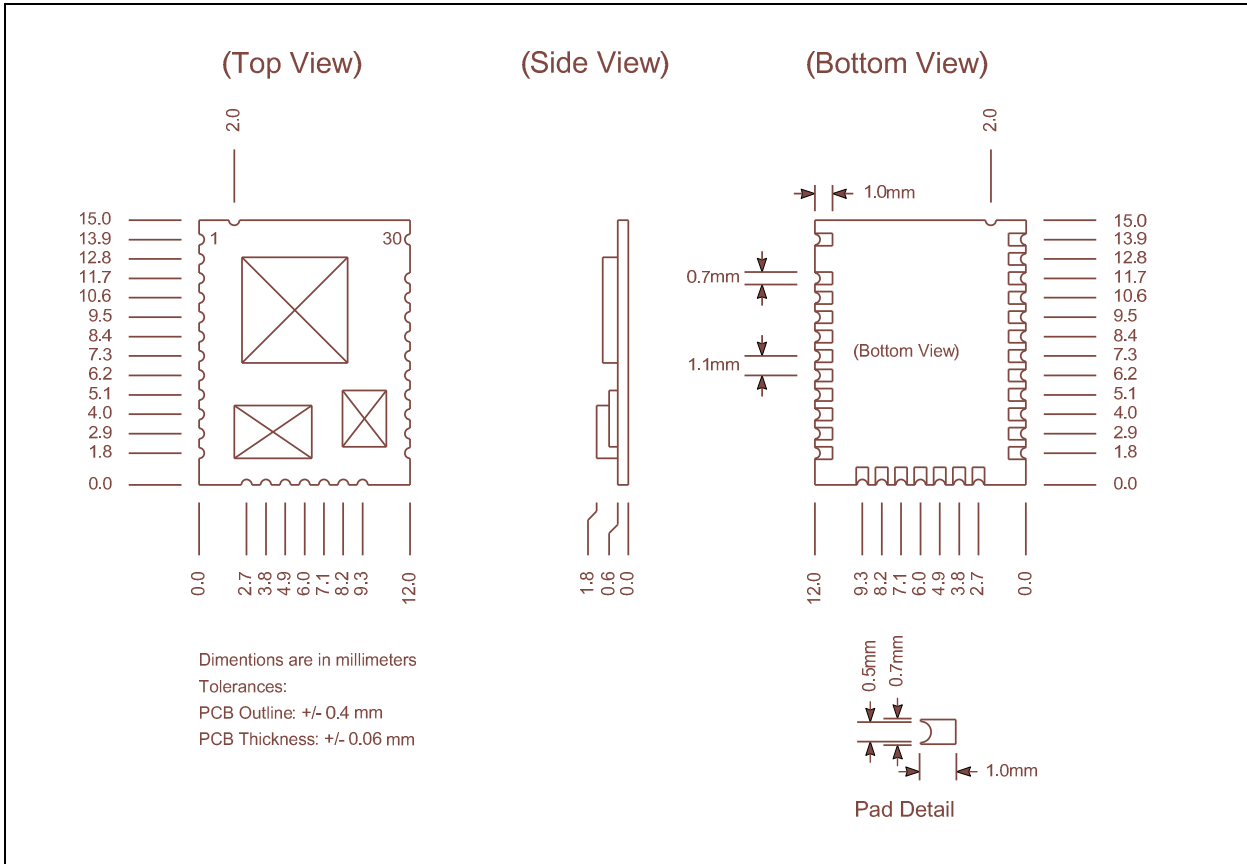
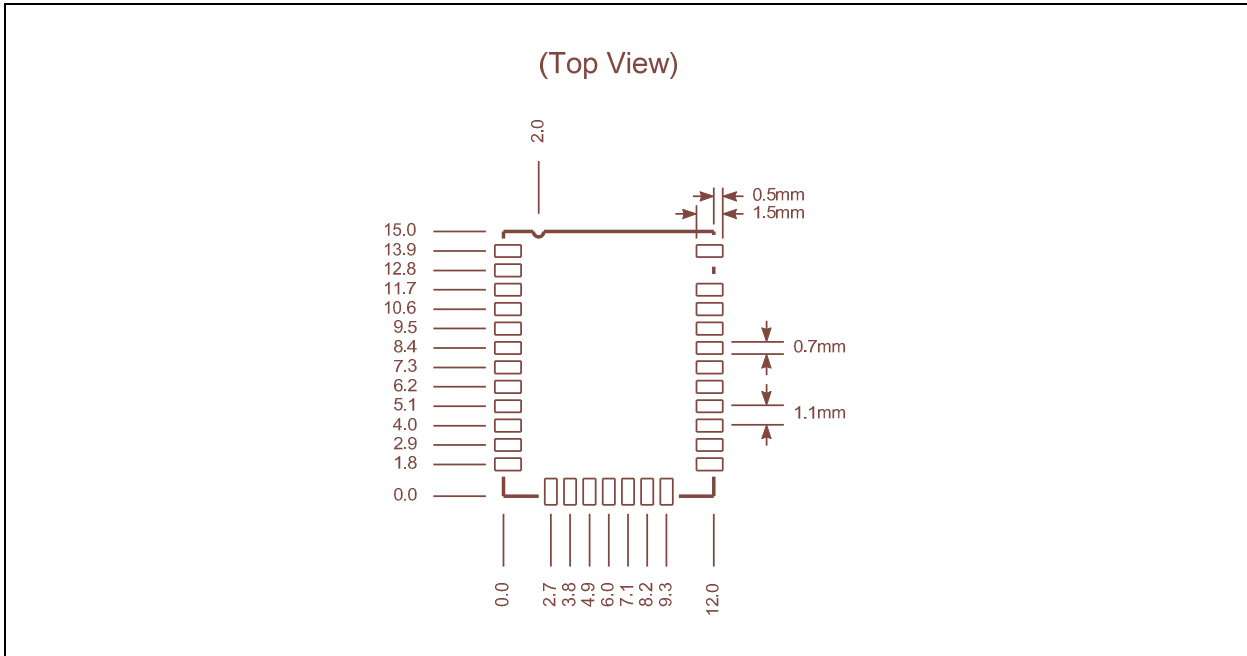
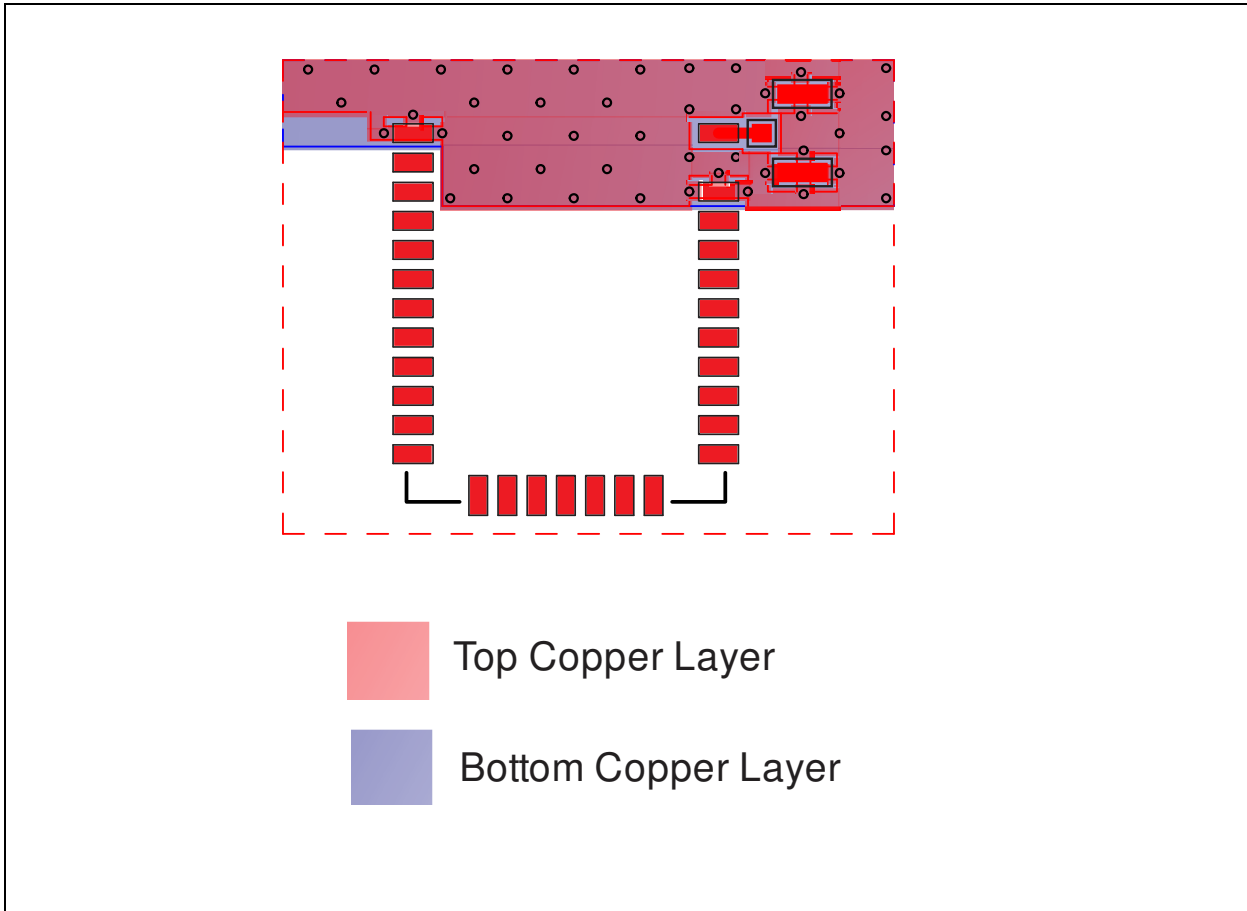

FIGURE 11-5: BM78SPP05NC2 RECOMMENDED PCB FOOTPRINT



BM78SPPS5MC2 , RN4678

FIGURE 11-6: BM78SPP05NCS HOST PCB MOUNTING SUGGESTION



BM78SPPS5MC2 , RN4678

12.0 ANTENNA PLACEMENT RULE

For Bluetooth product, antenna placement will affect whole system performance. Antenna need free space to transmit RF signal, it can't be surround by GND plane.

Here are some examples of good and poor placement on a Main Application board with GND plane.

FIGURE 12-1: KEEP OUT AREA SUGGESTION FOR ANTENNA

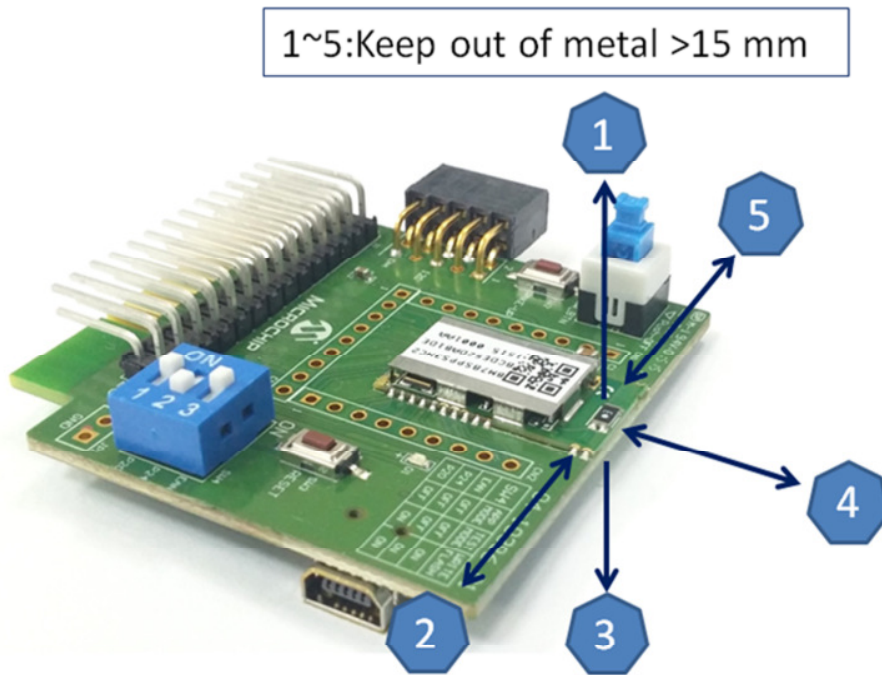

For more detail free space of antenna placement design, you can reference the design rule of antenna produce vendor.

BM78SPPS5MC2 , RN4678

12-2 BM78SPPS5NC2 Ceramic Chip Antenna

The BM78SPPS5NC2 module contains an integral ceramic chip antenna. The antenna performance on the module is shown in Figure 12-2.

FIGURE 12-2: BM78SPPS5NC2 ANTENNA RADIATION PATTERN

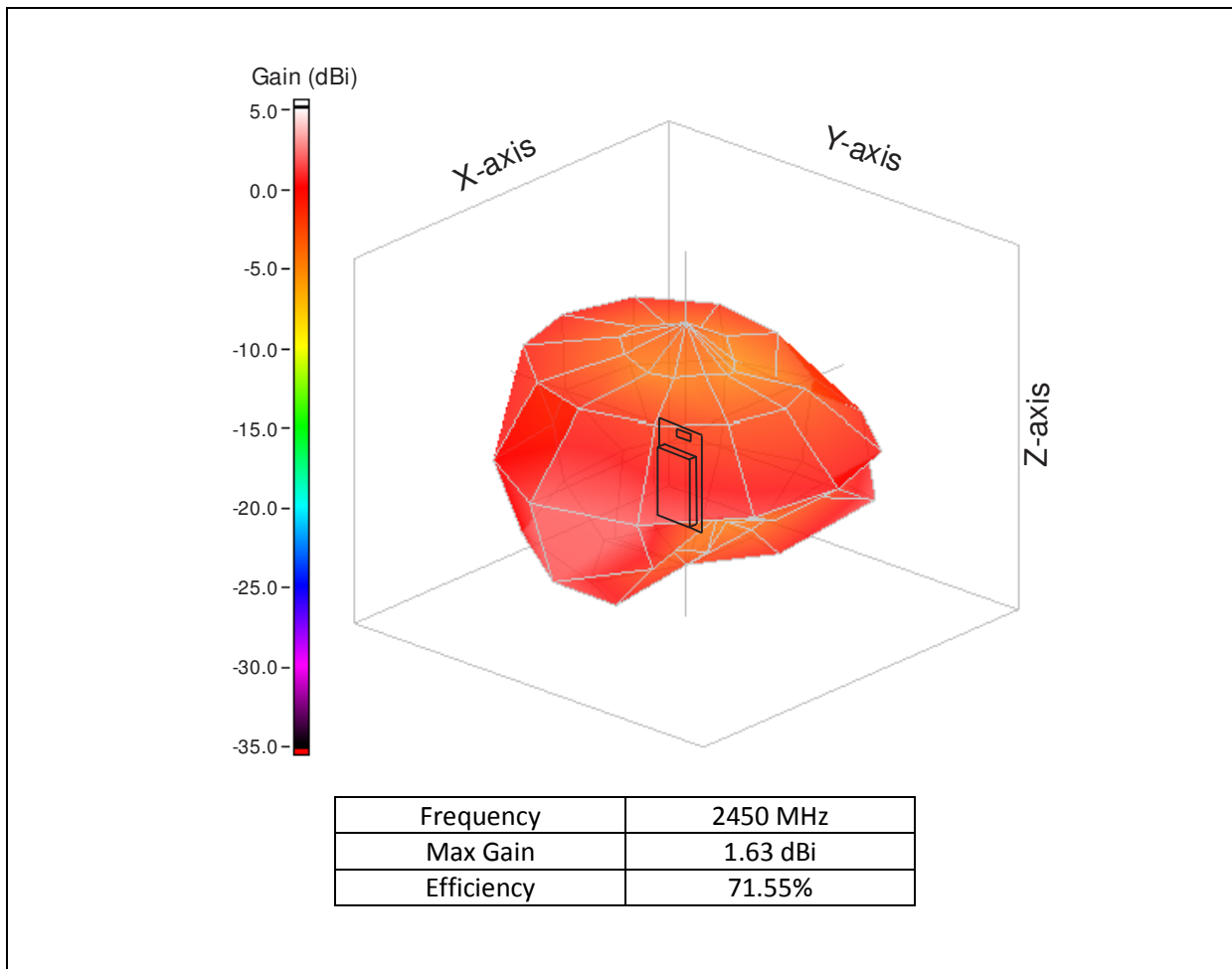

13.0 Electrical Characteristics

Recommended Operating Conditions

Rating		Min	Typ	Max
Storage temperature range		-65°C	+25°C	+150°C
Ambient Operating temperature range		-20°C	+25°C	+70°C
Relative Humidity (Operating)		10%		90%
Relative Humidity (Storage)		10%		90%
ESD	HBM		±2KV	
	MM		200V	
HTOL (*1)			1000 hrs	
Supply voltage : BAT_IN		3.2V		4.3V
SW_BTN		1.7V		4.3V
LED1				3.6V
Reset $V_{TH,res}$ threshold voltage			1.6V	
IOH				12mA
IOL				12mA
VIL input logic levels low		-0.3V		0.8V
VIH input logic levels high		2.0V		3.6V
VOL output logic levels low				0.4V
VOH output logic levels high		2.4V		
RF TX mode				43 mA
RF RX mode				37 mA

1) HTOL life test condition : +125°C , BAT_IN=4.2V, LDO33_O= 3.3V, LDO18_O=1.9V

1.8V LDO

(*1)(*2)	Min	Typ	Max	Unit
Operation Temperature	-20		70	°C
Input Voltage (V_{in}) ^(*3)	2.0		3.6	V
Output Current ($V_{IN}=3.0V$ /load regulation with 80mV drop)		100		mA
Quiescent Current ($V_{in} < 3.0V$)		13		uA

- 1) With 1uF capacitors at LDO18_O as the condition of IP verification.
- 2) Output voltage can calibration by MP tool

3.3V LDO

(*1)(*2)	Min	Typ	Max	Unit
Operation Temperature	-20		70	°C
Input Voltage (V_{in})	3.2		4.3	V
Output Current ($V_{IN}=3.6V$ / load regulation with 100mV drop)		100		mA
Quiescent Current($V_{IN}=3.6V$)		150		uA

- 1) With 10uF capacitor at LDO33_O as the condition of IP verification
- 2) Output voltage can calibration by MP tool

PMU LDO

(*1)(*2)	Min	Typ	Max	Unit
Operation Temperature	-20		70	°C
Input Voltage (V_{in})	3.2		4.3	V
Output Current ($V_{IN}=3.6V$ / load regulation with 0.3mV drop)		100		uA
Quiescent Current($V_{IN}=3.6V$)		120		uA

- 1) With 1uF capacitor at PMULDO_O as the condition of IP verification.
- 2) Output voltage can calibration by MP tool

SAR-ADC and Battery Voltage Detector

	Min	Typ	Max	Unit
Operation Temperature	-20		70	°C
AVDD_SAR power supply		1.8		V
SAR_BAT(BAT_IN)	1.1		4.5	V
Resolution		10		bit

Operating Current (including bandgap)			1	mA
Shutdown Current			1	uA

1) SAR_BAT is shorted to BAT_IN internally for battery voltage detection.

Intensity controllable LED driver

	Min	Typ	Max	Unit
Operation Temperature	-20		70	°C
Open-drain Voltage			3.6	V
Current Step		0.3		mA
Programmable Current Range	0		5	mA
Intensity control		16		step
Power down open-drain current			1	uA
Shutdown Current			1	uA

14.0 Radio Characteristics:

Transmitter Performance (25°C)

	Min	Typ	Max	Bluetooth specification	Unit
BDR power		2		-6 ~ +4	dBm
EDR power		0		-6 ~ +4	
LE power		2		-20 ~ +10	

NOTE:

- 1) The RF Transmit power calibrated during production using MP Tool software and MT8852 Bluetooth Test equipment.
- 2) Test condition: VCC_RF= 1.80V, temperature=25 °C.

Receiver Performance (25°C)

Basic Data Rate	Min	Typ	Max	Bluetooth specification	Unit
BDR Sensitivity		-90		≤-70	dBm
EDR 2M Sensitivity		-90			
EDR 3M Sensitivity		-82			
LE Sensitivity		-92			

NOTE:

- 1) Test condition: VCC_RF= 1.80V, temperature=25 °C.

15.0 System Current Consumption

SUPPLY CONSUMPTION – CLASSIC ⁽¹⁾

Parameter	Current (avg.) Units : mA	Notes
Standby mode	2.543	
shutdown mode	0.187	
Connected + Sniff, Master (no data)	0.541	No data was transmitted Sniff interval = 500ms
Connected + Sniff, Slave (no data)	0.551	No data was transmitted Sniff interval = 500ms
Data, Master	10.67	(Data transmitted at 115200 bps; block size=500)
Data, Slave	14.87	(Data transmitted at 115200 bps; block size=500)

Note 1: Classic BR/EDR, RX_IND Function Enabled

2. The DATA from IS1678S-151

SUPPLY CONSUMPTION –LOW ENERGY ⁽¹⁾

Parameter	Current (avg.) Units : mA	Notes
Shutdown mode	0.13	
LE fast advertising	1.21	LE fast advertising interval = 100 ms
	0.88	LE fast advertising interval = 160 ms
	0.48	LE fast advertising interval = 500 ms
	1.72	LE fast advertising interval = 100 ms + Beacon 100 ms
	0.62	LE fast advertising interval = 500 ms + Beacon 500 ms
Reduced Power advertising	0.39	LE Reduced Power advertising interval = 961 ms
	1.00	LE Reduced Power advertising interval = 961 ms+ Beacon 100 ms
	0.51	LE Reduced Power advertising interval = 961 ms + Beacon 500 ms
Connected (No data)	0.39	Connection interval = 1500 ms
	0.43	Connection interval = 600 ms
Connected (iPhone6→IC)	0.45	Connection interval = 500 ms
	0.60	Connection interval = 200 ms
Connected (IC→iPhone6)	6.6	Connection interval = 500 ms
	7.0	Connection interval = 200 ms

Note 1. Only Low Energy, RX_IND Function Enabled

2. The DATA from IS1678S-151

16.0 REFERENCE CIRCUIT

BM78 Reference Circuit

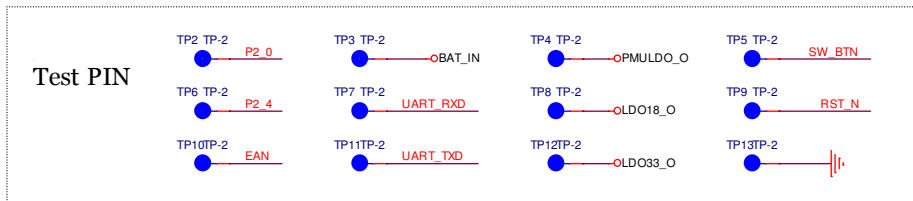
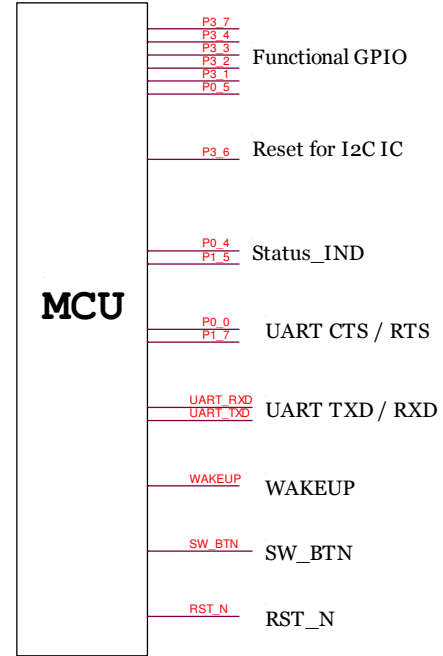
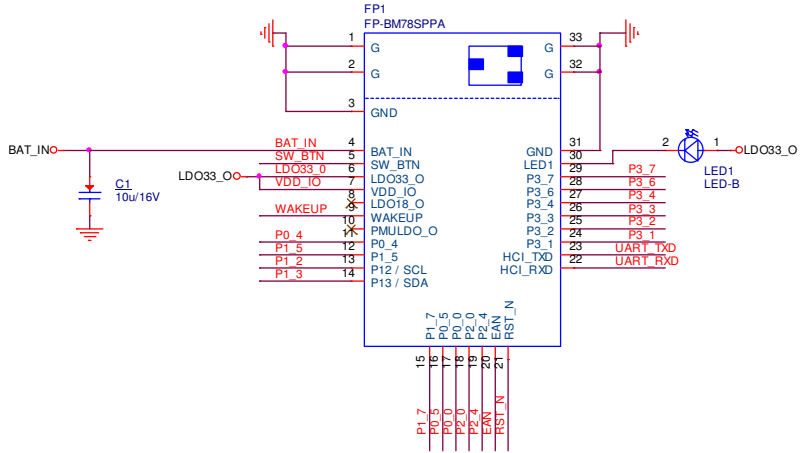

		5F, No.5, Industry E. Rd. VII, Hsinchu Science Park, Hsinchu City 30078, Taiwan TEL. 886-3-5778385
BM78S REFERENCE CIRCUIT		0222
Custom	MAIN CIRCUIT	1.0
Friday, April 24, 2015		2 4

1.0 REGULATORY APPROVAL

This section outlines the regulatory information for the BM78SSPS5MC2 module for the following countries:

- United States
- Canada
- Europe
- Australia
- Japan
- Korea
- Taiwan
- China

1.2 United States

The BM78SSPS5MC2 module has received Federal Communications Commission (FCC) CFR47 Telecommunications, Part 15 Subpart C “Intentional Radiators” modular approval in accordance with Part 15.212 Modular Transmitter approval. Modular approval allows the end user to integrate the BM78 module into a finished product without obtaining subsequent and separate FCC approvals for intentional radiation, provided no changes or modifications are made to the module circuitry. Changes or modifications could void the user’s authority to operate the equipment. The end user must comply with all of the instructions provided by the Grantee, which indicate installation and/or operating conditions necessary for compliance.

The finished product is required to comply with all applicable FCC equipment authorization regulations, requirements and equipment functions not associated with the transmitter module portion. For example, compliance must be demonstrated to regulations for other transmitter components within the host product; to requirements for unintentional radiators (Part 15 Subpart B “Unintentional Radiators”), such as digital devices, computer peripherals, radio receivers, etc.; and to additional authorization requirements for the non-transmitter functions on the transmitter module (i.e., Verification, or Declaration of Conformity) (e.g., transmitter modules may also contain digital logic functions) as appropriate.

1.2.1 LABELING AND USER INFORMATION REQUIREMENTS

The BM78 module has been labeled with its own FCC ID number, and if the FCC ID is not visible when the module is installed inside another device, then the outside of the finished product into which the module is installed must also display a label referring to the enclosed module. This exterior label can use wording as follows:

Contains Transmitter Module FCC ID: A8TBM78ABCDEF GH

or

Contains FCC ID: A8TBM78ABCDEF GH

This device complies with Part 15 of the FCC Rules. Operation is subject to the following two conditions: (1) this device may not cause harmful interference, and (2) this device must accept any interference received, including interference that may cause undesired operation

A user’s manual for the finished product should include the following statement:

This equipment has been tested and found to comply with the limits for a Class B digital device, pursuant to part 15 of the FCC Rules. These limits are designed to provide reasonable protection against harmful interference in a residential installation. This equipment generates, uses and can radiate radio frequency energy, and if not installed and used in accordance with the instructions, may cause harmful interference to radio communications. However, there is no guarantee that interference will not occur in a particular installation. If this equipment does cause harmful interference to radio or television reception, which can be determined by turning the equipment off and on, the user is encouraged to try to correct the interference by one or more of the following measures:

- Reorient or relocate the receiving antenna.
- Increase the separation between the equipment and receiver.
- Connect the equipment into an outlet on a circuit different from that to which the receiver is connected.
- Consult the dealer or an experienced radio/TV technician for help.

Additional information on labeling and user information requirements for Part 15 devices can be found in KDB Publication 784748 available at the FCC Office of Engineering and Technology (OET) Laboratory Division Knowledge Database (KDB) <http://apps.fcc.gov/oetcf/kdb/index.cfm>.

1.2.2 RF EXPOSURE

All transmitters regulated by FCC must comply with RF exposure requirements. KDB 447498 General RF Exposure Guidance provides guidance in determining whether proposed or existing transmitting facilities, operations or devices comply with limits for human exposure to Radio Frequency (RF) fields adopted by the Federal Communications Commission (FCC).

From the FCC Grant: Output power listed is conducted. This grant is valid only when the module is sold to OEM integrators and must be installed by the OEM or OEM integrators. This transmitter is restricted for use with the specific antenna(s) tested in this application for Certification and must not be co-located or operating in conjunction with any other antenna or transmitters within a host device, except in accordance with FCC multi-transmitter product procedures.

1.2.3 HELPFUL WEB SITES

Federal Communications Commission (FCC): <http://www.fcc.gov>
FCC Office of Engineering and Technology (OET) Laboratory Division Knowledge Database (KDB): <http://apps.fcc.gov/oetcf/kdb/index.cfm>

1.3 Canada

The BM78SPPS5MC2 module has been certified for use in Canada under Industry Canada (IC) Radio Standards Specification (RSS) RSS-210 and RSS-Gen. Modular approval permits the installation of a module in a host device without the need to recertify the device.

1.3.1 LABELING AND USER INFORMATION REQUIREMENTS

Labeling Requirements for the Host Device (from Section 3.2.1, RSS-Gen, Issue 3, December 2010): The host device shall be properly labeled to identify the module within the host device.

The Industry Canada certification label of a module shall be clearly visible at all times when installed in the host device, otherwise the host device must be labeled to display the Industry Canada certification number of the module preceded by the words "Contains transmitter module", or the word "Contains", or similar wording expressing the same meaning, as follows:

Contains transmitter module IC: 12246A-BM78SPPS5M2

User Manual Notice for License-Exempt Radio Apparatus (from Section 7.1.3 RSS-Gen, Issue 3, December 2010): User manuals for license-exempt radio apparatus shall contain the following or equivalent notice in a conspicuous location in the user manual or alternatively on the device or both:

This device complies with Industry Canada license-exempt RSS standard(s). Operation is subject to the following two conditions: (1) this device may not cause interference, and (2) this device must accept any interference, including interference that may cause undesired operation of the device.

Le présent appareil est conforme aux CNR d'Industrie Canada applicables aux appareils radio exempts de licence. L'exploitation est autorisée aux deux conditions suivantes: (1) l'appareil ne doit pas produire de brouillage, et (2) l'utilisateur de l'appareil doit accepter tout brouillage radioélectrique subi, même si le brouillage est susceptible d'en compromettre le fonctionnement.

1.3.2 RF EXPOSURE

All transmitters regulated by IC must comply with RF exposure requirements listed in RSS-102 - Radio Frequency (RF) Exposure Compliance of Radiocommunication Apparatus (All Frequency Bands).

(Get direct quote from Certificate and place here)

1.3.3 HELPFUL WEB SITES

Industry Canada: <http://www.ic.gc.ca/>

1.4 Europe

The BM78SPPS5MC2 module is an R&TTE Directive assessed radio module that is CE marked and has been manufactured and tested with the intention of being integrated into a final product.

The BM78 module has been tested to R&TTE Directive 1999/5/EC Essential Requirements for Health and Safety (Article (3.1(a)), Electromagnetic Compatibility (EMC) (Article 3.1(b)), and Radio (Article 3.2) and are summarized in **Table 3-1: European Compliance Testing**. A Notified Body Opinion has also been issued. All test reports are available on the BM78 product web page at <http://www.microchip.com/bm78>.

The R&TTE Compliance Association provides guidance on modular devices in document **Technical Guidance Note 01** available at http://www.rtteca.com/html/download_area.htm.

Note: To maintain conformance to the testing listed in **Table 3-1: European Compliance Testing**, the module shall be installed in accordance with the installation instructions in this data sheet and shall not be modified.

When integrating a radio module into a completed product the integrator becomes the manufacturer of the final product and is therefore responsible for demonstrating compliance of the final product with the essential requirements of the R&TTE Directive.

1.4.1 LABELING AND USER INFORMATION REQUIREMENTS

The label on the final product which contains the BM77 module must follow CE marking requirements. The R&TTE Compliance Association **Technical Guidance Note 01** provides guidance on final product CE marking.

1.4.2 ANTENNA REQUIREMENTS

From R&TTE Compliance Association document **Technical Guidance Note 01**:

Provided the integrator installing an assessed radio module with an integral or specific antenna and installed in conformance with the radio module manufacturer's installation instructions requires no further evaluation under Article 3.2 of the R&TTE Directive and does not require further involvement of an R&TTE Directive Notified Body for the final product. [Section 2.2.4]

The European Compliance Testing listed in **Table 3-1** was performed using the integral ceramic chip antenna.

TABLE 3-1: EUROPEAN COMPLIANCE TESTING

Certification	Standards	Article	Laboratory	Report Number	Date
Safety	EN 60950-1:2006+A11:2009+A1:2010	(3.1(a))			
Health	EN 50371:2002-03				

EMC	EN 301 489-1 V1.8.1 (2008-04)	(3.1(b))			
	EN 301 489-17 V2.1.1 (2009-05)				
Radio	EN 300 328 V1.7.1 (2006-10)	(3.2)			
Notified Body Opinion					

1.4.3 HELPFUL WEB SITES

A document that can be used as a starting point in understanding the use of Short Range Devices (SRD) in Europe is the European Radio Communications Committee (ERC) Recommendation 70-03 E, which can be downloaded from the European Radio Communications Office (ERO) at: <http://www.ero.dk/>.

Additional helpful web sites are:

- Radio and Telecommunications Terminal Equipment (R&TTE):
http://ec.europa.eu/enterprise/rtte/index_en.htm
- European Conference of Postal and Telecommunications Administrations (CEPT):
<http://www.cept.org>
- European Telecommunications Standards Institute (ETSI):
<http://www.etsi.org>
- European Radio Communications Office (ERO):
<http://www.ero.dk>
- The Radio and Telecommunications Terminal Equipment Compliance Association (R&TTE CA):
<http://www.rtteca.com/>

1.5 Australia

The Australia radio regulations do not provide a modular approval policy similar to the United States (FCC) and Canada (IC). However, BM77 module RF transmitter test reports can be used in part to demonstrate compliance in accordance with ACMA Radio communications "Short Range Devices" Standard 2004 (The Short Range Devices standard calls up the AS/NZS 4268:2008 industry standard). The BM77 module test reports can be used as part of the product certification and compliance folder. For more information on the RF transmitter test reports, contact Microchip Technology Australia sales office.

To meet overall Australian final product compliance, the developer must construct a compliance folder containing all relevant compliance test reports e.g. RF, EMC, electrical safety and DoC (Declaration of Conformity) etc. It is the responsibility of the integrator to know what is required in the compliance folder for ACMA compliance. All test reports are available on the BM78 product web page at <http://www.microchip.com>. For more information on Australia compliance, refer to the Australian Communications and Media Authority web site <http://www.acma.gov.au/>.

1.5.1 HELPFUL WEB SITES

The Australian Communications and Media Authority: www.acma.gov.au/.

1.6 Japan

The BM78SPPS5MC2 module has received type certification and is labeled with its own technical conformity mark and certification number as required to conform to the technical standards regulated by the Ministry of Internal Affairs and Communications (MIC) of Japan pursuant to the Radio Act of Japan.

Integration of this module into a final product does not require additional radio certification provided installation instructions are followed and no modifications of the module are allowed. Additional testing may be required:

- If the host product is subject to electrical appliance safety (for example, powered from an AC mains), the host product may require Product Safety Electrical Appliance and Material (PSE)

testing. The integrator should contact their conformance laboratory to determine if this testing is required.

- There is an voluntary Electromagnetic Compatibility (EMC) test for the host product administered by VCCI: http://www.vcci.jp/vcci_e/index.html

1.6.1 LABELING AND USER INFORMATION REQUIREMENTS

The label on the final product which contains the BM78 module must follow Japan marking requirements. The integrator of the module should refer to the labeling requirements for Japan available at the Ministry of Internal Affairs and Communications (MIC) website.

The BM78 module is labeled with its own technical conformity mark and certification number. The final product in which this module is being used must have a label referring to the type certified module inside:

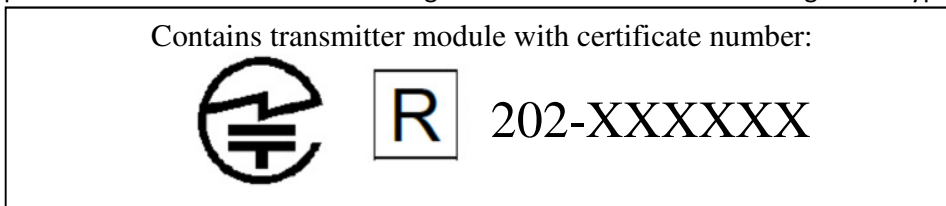

1.6.2 HELPFUL WEB SITES

Ministry of Internal Affairs and Communications (MIC): <http://www.tele.soumu.go.jp/e/index.htm>
Association of Radio Industries and Businesses (ARIB): <http://www.arib.or.jp/english/>

1.7 Korea

The BM78SPPS5MC2 module has received certification of conformity in accordance with the Radio Waves Act. Integration of this module into a final product does not require additional radio certification provided installation instructions are followed and no modifications of the module are allowed.

1.7.1 LABELING AND USER INFORMATION REQUIREMENTS

The label on the final product which contains the BM78 module must follow KC marking requirements. The integrator of the module should refer to the labeling requirements for Korea available on the Korea Communications Commission (KCC) website.

The BM78 module is labeled with its own KC mark. The final product requires the KC mark and certificate number of the module:

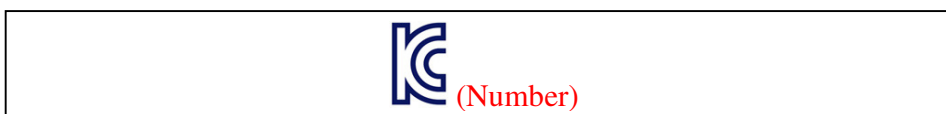

1.7.2 HELPFUL WEB SITES

Korea Communications Commission (KCC): <http://www.kcc.go.kr>
National Radio Research Agency (RRA): <http://rra.go.kr>

1.8 Taiwan

The BM78SPPS5MC2 module has received compliance approval in accordance with the Telecommunications Act. Customers seeking to use the compliance approval in their product should contact Microchip Technology sales or distribution partners to obtain a Letter of Authority.

Integration of this module into a final product does not require additional radio certification provided installation instructions are followed and no modifications of the module are allowed.

1.8.1 LABELING AND USER INFORMATION REQUIREMENTS

The BM77 module is labeled with its own NCC mark and certificate number as below:

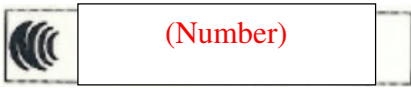

The user's manual should contain below warning (for RF device) in traditional Chinese:

注意！

依據 低功率電波輻射性電機管理辦法

第十二條 經型式認證合格之低功率射頻電機，非經許可，公司、商號或使用者均不得擅自變更頻率、加大功率或變更原設計之特性及功能。

第十四條 低功率射頻電機之使用不得影響飛航安全及干擾合法通信；經發現有干擾現象時，應立即停用，並改善至無干擾時方得繼續使用。

前項合法通信，指依電信規定作業之無線電信。

低功率射頻電機須忍受合法通信或工業、科學及醫療用電波輻射性電機設備之干擾。

1.8.2 HELPFUL WEB SITES

National Communications Commission (NCC): <http://www.ncc.gov.tw>

1.9 Other Regulatory Jurisdictions

Should other regulatory jurisdiction certification be required by the customer, or the customer need to recertify the module for other reasons, a certification utility is available. For further regulatory Certification Utility and documentation, contact ISSC Technologies Corp.

FIGURE 20-1: Reflow Profile

Standard : IPC/JEDEC J-STD-020

Condition :

Preheat : 150~200°C 、 60~120 seconds

Average ramp-up rate (217°C to peak): 3°C/sec max.

Temperature maintained above 217°C : 60~150 seconds

Time within 5°C of peak temperature: 30 ~ 40 seconds.

Peak temperature : 260 +5/-0 °C

Ramp-down rate (peak to 217°C) : 6°C/sec. max.

Time 25°C to peak temperature : 8 minutes max.

Cycle interval : 5 minutes

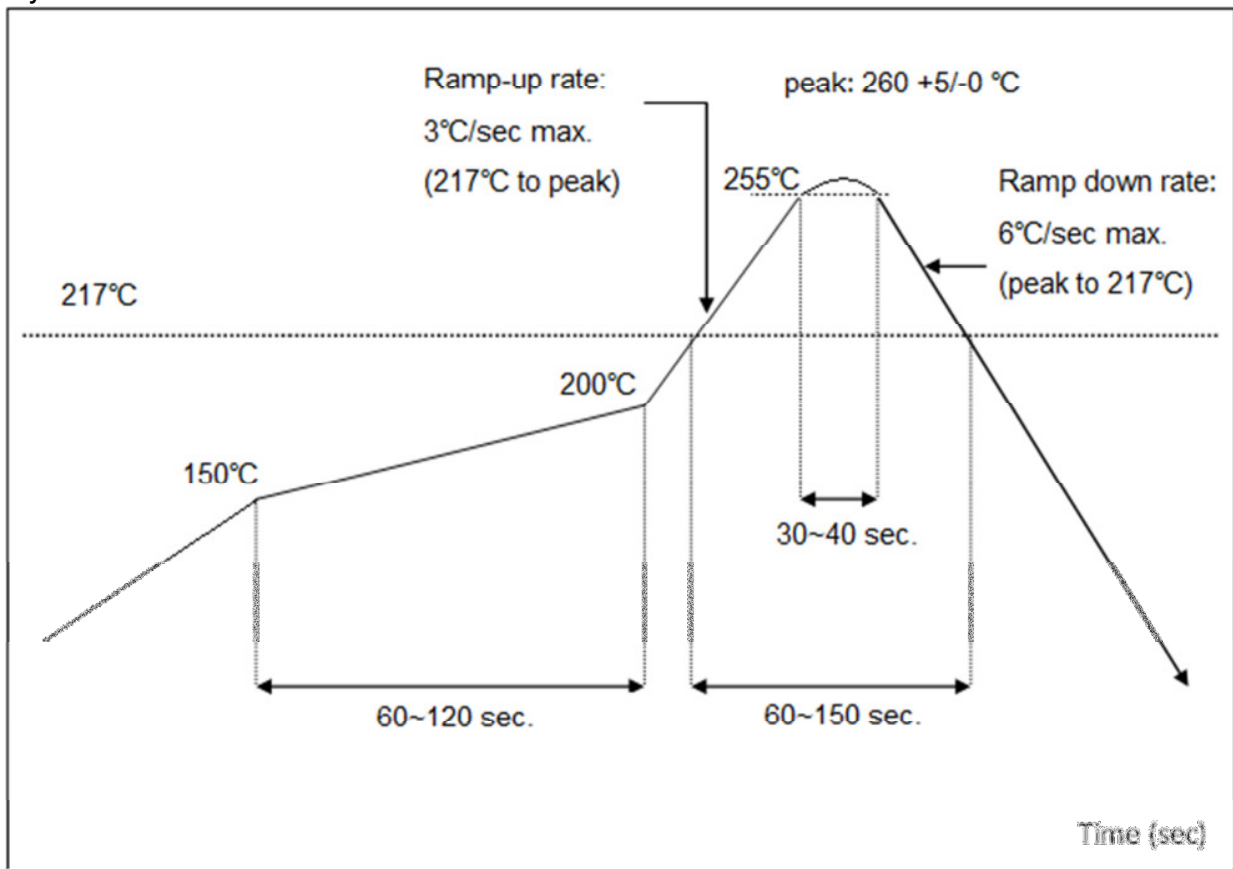

Soldering Recommendations

Stereo module was assembled using standard lead-free reflow profile IPC/JEDEC J-STD-020. The module can be soldered to the main PCB using standard leaded and lead-free solder reflow profiles. To avoid damaging of the module, the recommendations are listed as follows:

- Refer to Microchip Technology Application Note AN233 Solder Reflow Recommendation (DS00233) for the soldering reflow recommendations
- Do not exceed peak temperature (Tp) of 250 degree C
- Refer to the solder paste data sheet for specific reflow profile recommendations
- Use no-clean flux solder paste
- Do not wash as moisture can be trapped under the shield
- Use only one flow. If the PCB requires multiple flows, apply the module on the final flow.

ORDERING INFORMATION

TABLE 4-1: ORDERING INFORMATION

Part Number	Description
BM78SPPS5NC2-000---	Bluetooth® 4.0 Dual Mode, Class 2, Surface Mount module with integral antenna, with shield
BM78SPP05NC2-000---	Bluetooth® 4.0 Dual Mode, Class 2, Surface Mount module, external antenna, no shield

A.3.3 HELPFUL WEB SITES

A document that can be used as a starting point in understanding the use of Short Range Devices (SRD) in Europe is the European Radio Communications Committee (ERC) Recommendation 70-03 E, which can be downloaded from the European Radio Communications Office (ERO) at: <http://www.ero.dk/>.

Additional helpful web sites are:

- Radio and Telecommunications Terminal Equipment (R&TTE):
http://ec.europa.eu/enterprise/rtte/index_en.htm
- European Conference of Postal and Telecommunications Administrations (CEPT):
<http://www.cept.org>
- European Telecommunications Standards Institute (ETSI):
<http://www.etsi.org>
- European Radio Communications Office (ERO):
<http://www.ero.dk>
- The Radio and Telecommunications Terminal Equipment Compliance Association (R&TTE CA):
<http://www.rtteca.com/>



MICROCHIP

Worldwide Sales and Service

AMERICAS

Corporate Office
2355 West Chandler Blvd.
Chandler, AZ 85224-6199
Tel: 480-792-7200
Fax: 480-792-7277
Technical Support:
[http://www.microchip.com/
support](http://www.microchip.com/support)

Web Address:
www.microchip.com

Atlanta
Duluth, GA
Tel: 678-957-9614
Fax: 678-957-1455

Austin, TX
Tel: 512-257-3370

Boston
Westborough, MA
Tel: 774-760-0087
Fax: 774-760-0088

Chicago
Itasca, IL
Tel: 630-285-0071
Fax: 630-285-0075

Cleveland
Independence, OH
Tel: 216-447-0464
Fax: 216-447-0643

Dallas
Addison, TX
Tel: 972-818-7423
Fax: 972-818-2924

Detroit
Novi, MI
Tel: 248-848-4000

Houston, TX
Tel: 281-894-5983

Indianapolis
Noblesville, IN
Tel: 317-773-8323
Fax: 317-773-5453

Los Angeles
Mission Viejo, CA
Tel: 949-462-9523
Fax: 949-462-9608

New York, NY
Tel: 631-435-6000

San Jose, CA
Tel: 408-735-9110

Canada - Toronto
Tel: 905-673-0699
Fax: 905-673-6509

ASIA/PACIFIC

Asia Pacific Office
Suites 3707-14, 37th Floor
Tower 6, The Gateway
Harbour City, Kowloon
Hong Kong
Tel: 852-2943-5100
Fax: 852-2401-3431

Australia - Sydney
Tel: 61-2-9868-6733
Fax: 61-2-9868-6755

China - Beijing
Tel: 86-10-8569-7000
Fax: 86-10-8528-2104

China - Chengdu
Tel: 86-28-8665-5511
Fax: 86-28-8665-7889

China - Chongqing
Tel: 86-23-8980-9588
Fax: 86-23-8980-9500

China - Hangzhou
Tel: 86-571-8792-8115
Fax: 86-571-8792-8116

China - Hong Kong SAR
Tel: 852-2943-5100
Fax: 852-2401-3431

China - Nanjing
Tel: 86-25-8473-2460
Fax: 86-25-8473-2470

China - Qingdao
Tel: 86-532-8502-7355
Fax: 86-532-8502-7205

China - Shanghai
Tel: 86-21-5407-5533
Fax: 86-21-5407-5066

China - Shenyang
Tel: 86-24-2334-2829
Fax: 86-24-2334-2393

China - Shenzhen
Tel: 86-755-8864-2200
Fax: 86-755-8203-1760

China - Wuhan
Tel: 86-27-5980-5300
Fax: 86-27-5980-5118

China - Xian
Tel: 86-29-8833-7252
Fax: 86-29-8833-7256

China - Xiamen
Tel: 86-592-2388138
Fax: 86-592-2388130

China - Zhuhai
Tel: 86-756-3210040
Fax: 86-756-3210049

ASIA/PACIFIC

India - Bangalore
Tel: 91-80-3090-4444
Fax: 91-80-3090-4123

India - New Delhi
Tel: 91-11-4160-8631
Fax: 91-11-4160-8632

India - Pune
Tel: 91-20-3019-1500

Japan - Osaka
Tel: 81-6-6152-7160
Fax: 81-6-6152-9310

Japan - Tokyo
Tel: 81-3-6880-3770
Fax: 81-3-6880-3771

Korea - Daegu
Tel: 82-53-744-4301
Fax: 82-53-744-4302

Korea - Seoul
Tel: 82-2-554-7200
Fax: 82-2-558-5932 or
82-2-558-5934

Malaysia - Kuala Lumpur
Tel: 60-3-6201-9857
Fax: 60-3-6201-9859

Malaysia - Penang
Tel: 60-4-227-8870
Fax: 60-4-227-4068

Philippines - Manila
Tel: 63-2-634-9065
Fax: 63-2-634-9069

Singapore
Tel: 65-6334-8870
Fax: 65-6334-8850

Taiwan - Hsin Chu
Tel: 886-3-5778-366
Fax: 886-3-5770-955

Taiwan - Kaohsiung
Tel: 886-7-213-7830

Taiwan - Taipei
Tel: 886-2-2508-8600
Fax: 886-2-2508-0102

Thailand - Bangkok
Tel: 66-2-694-1351
Fax: 66-2-694-1350

EUROPE

Austria - Wels
Tel: 43-7242-2244-39
Fax: 43-7242-2244-393

Denmark - Copenhagen
Tel: 45-4450-2828
Fax: 45-4485-2829

France - Paris
Tel: 33-1-69-53-63-20
Fax: 33-1-69-30-90-79

Germany - Dusseldorf
Tel: 49-2129-3766400

Germany - Munich
Tel: 49-89-627-144-0
Fax: 49-89-627-144-44

Germany - Pforzheim
Tel: 49-7231-424750

Italy - Milan
Tel: 39-0331-742611
Fax: 39-0331-466781

Italy - Venice
Tel: 39-049-7625286

Netherlands - Drunen
Tel: 31-416-690399
Fax: 31-416-690340

Poland - Warsaw
Tel: 48-22-3325737

Spain - Madrid
Tel: 34-91-708-08-90
Fax: 34-91-708-08-91

Sweden - Stockholm
Tel: 46-8-5090-4654

UK - Wokingham
Tel: 44-118-921-5800
Fax: 44-118-921-5820