

RN-41/RN-41-N Class 1 Bluetooth Module

Features

- Fully qualified Bluetooth[®] version 2.1 module, supports version 2.1 + Enhanced Data Rate (EDR)
- Backwards-compatible with Bluetooth version 2.0, 1.2, and 1.1
- Postage stamp sized form factor, 13.4 mm x 25.8 mm x 2 mm
- Low power (30 mA connected, < 10 mA sniff mode)
- UART (SPP or HCI) and USB (HCI only) data connection interfaces
- Sustained SPP data rates: 240 Kbps (slave), 300 Kbps (master)
- HCI data rates: 1.5 Mbps sustained, 3.0 Mbps burst in HCI mode
- Embedded Bluetooth stack profiles included (requires no host stack): GAP, SDP, RFCOMM, and L2CAP protocols, with SPP and DUN profile support
- Bluetooth SIG qualified, end product listing
- Castellated SMT pads for easy and reliable PCB mounting
- Class 1 high power amplifier with on board ceramic RF chip antenna (RN-41) or without antenna (RN-41-N)
- Certifications: FCC, ICS, CE
- Environmentally friendly, RoHS compliant



Figure 1. RN-41 Block Diagram

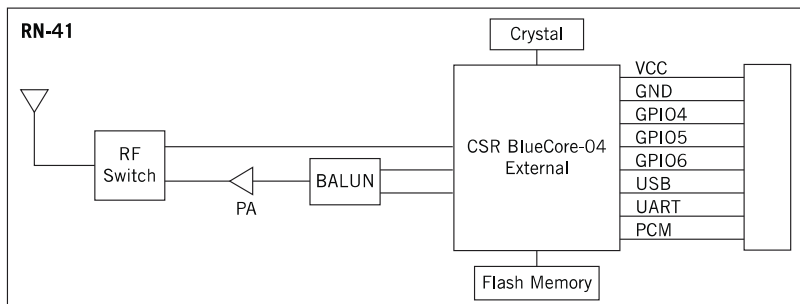

Applications

- Cable replacement
- Barcode scanners
- Measurement and monitoring systems
- Industrial sensors and controls
- Medical devices
- Asset tracking

Description

The RN-41 module is a small form factor, low power, class 1 Bluetooth radio that is ideal for designers who want to add wireless capability to their products without spending significant time and money developing Bluetooth-specific hardware and software. The RN-41 supports multiple interface protocols, is simple to design in, and is fully certified, making it a complete embedded Bluetooth solution. With its high-performance, on-chip antenna and support for Bluetooth EDR, the RN-41 delivers up to a 3-Mbps data rate for distances up to 100 meters. The RN-41 is also available without an antenna (RN-41-N).

OVERVIEW

- Baud rate speeds: 1,200 bps up to 921 Kbps, non-standard baud rates can be programmed
- Class I radio, 330' (100 m) range, 15 dBm output transmitter, -80 dBm typical receive sensitivity
- Frequency 2.402 ~ 2.480 MHz
- FHSS/GFSK modulation, 79 channels at 1-MHz intervals
- Secure communication, 128-bit encryption
- Error correction for guaranteed packet delivery
- Configuration via the local UART and over-the-air RF
- Auto-discovery/pairing does not require software configuration (supports instant cable replacement)
- Auto-connect master, I/O pin (DTR), and character-based trigger modes

The module's moisture sensitivity level (MSL) is 1. Table 1 shows the module's size and weight.

Table 1. Module Size & Weight

Parameter	RN-41	RN-41-N	Units
Size	13.4 x 25.8 x 2	13.4 x 19 x 2	mm
Weight	0.055	0.020	Oz.

Tables 2 through 5 provide detailed specifications for the module.

Table 2. Environmental Conditions

Parameter	Value
Temperature Range (Operating)	-40° C ~ 85° C
Temperature Range (Storage)	-40° C ~ 85° C
Relative Humidity (Operating)	.90%
Relative Humidity (Storage)	.90%

Table 3. Electrical Characteristics

Parameter	Min.	Typ.	Max.	Units
Supply Voltage (DC)	3.0	3.3	3.6	V
RX Supply Current		35	60	mA
TX Supply Current		65	100	mA
Average Power Consumption				
Standby/Idle (Default Settings)		25		mA
Connected (Normal Mode)		30		mA
Connected (Low-Power Sniff)		8		mA
Standby/Idle (Deep Sleep Enabled)	250	2.5		mA

Table 4. Radio Characteristics

Parameter	Frequency (GHz)	Min.	Typ.	Max.	Bluetooth Specification	Units
Sensitivity at 0.1% BER	2.402	-	-80	-86	≤ -70	dBm
	2.441	-	-80	-86		dBm
	2.480	-	-80	-86		dBm
RF Transmit Power	2.402	15.0	16.0		≤ 20	dBm
	2.441	15.0	16.0			dBm
	2.480	15.0	16.0			dBm
Initial Carrier Frequency Tolerance	2.402	-	5	75	75	kHz
	2.441	-	5	75		kHz
	2.480	-	5	75		kHz
20-dB Bandwidth for Modulated Carrier		-	900	1000	≤ 1000	kHz
Drift (Five Slots Packet)		-	15	-	40	kHz
Drift Rate		-	13	-	20	kHz
$\Delta f_{1\text{avg}}$ Maximum Modulation	2.402	140	165	175	> 140	kHz
	2.441	140	165	175		kHz
	2.480	140	165	175		kHz
$\Delta f_{2\text{avg}}$ Minimum Modulation	2.402	140	190	-	115	kHz
	2.441	140	190	-		kHz
	2.480	140	190	-		kHz

Table 5. Digital I/O Characteristics

3.0 V ≤ VDD ≤ 3.3 V	Min.	Typ.	Max.	Units
Input Logic Level Low	-0.4	-	+0.8	V
Input Logic Level High	0.7 VDD	-	VDD + 0.4	V
Output Logic Level Low	-	-	0.2	V
Output Logic Level High	VDD - 0.2	-	-	V
All I/O pins (Except reset) Default to Weak Pull Down	+0.2	+1.0	+5.0	uA

Figure 2 shows the pinout and Table 6 describes the pins.

Figure 2. RN-41/RN-41-N Pinout

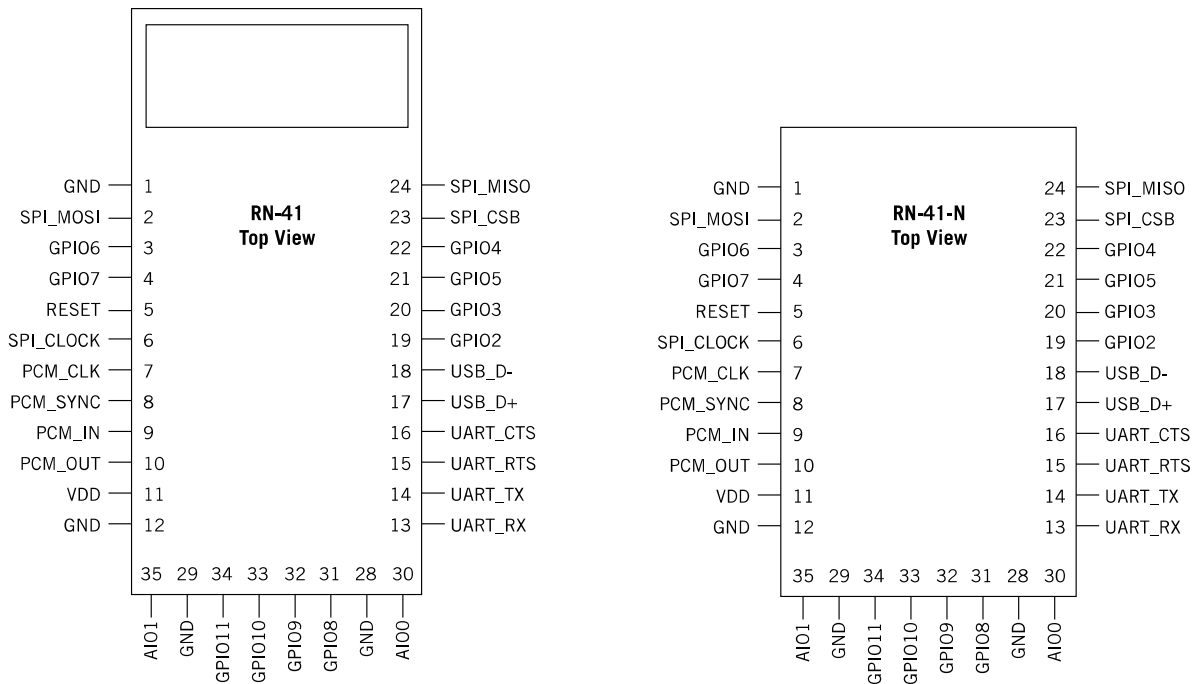

Table 6. Pin Description

Pin	Name	Description	Default
1	GND	Ground	–
2	SPI_MOSI	Programming only	No connect
3	GPIO6	Set Bluetooth master (high = auto-master mode)	Input to RN-41 with weak pulldown
4	GPIO7	Set baud rate (high = force 9,600, low = 115 K or firmware setting)	Input to RN-41 with weak pulldown
5	RESET	Active-low reset	Input to RN-41 with 1K pullup
6	SPI_CLK	Programming only	No Connect
7	PCM_CLK	PCM interface	No Connect
8	PCM_SYNC	PCM interface	No Connect
9	PCM_IN	PCM interface	No Connect
10	PCM_OUT	PCM interface	No Connect
11	VDD	3.3-V regulated power input	–
12	GND	Ground	–
13	UART_RX	UART receive input	Input to RN-41
14	UART_TX	UART transmit output	High level output from RN-41

Pin	Name	Description	Default
15	UART_RTS	UART RTS, goes high to disable host transmitter	Low level output from RN-41
16	UART_CTS	UART CTS, if set high, it disables transmitter	Low level input to RN-41
17	USB_D+	USB port	1.5 K pullup activated when USB port is ready (~500 ms after reset)
18	USB_D-	USB port	–
19	GPIO2	Status, high when connected, low otherwise	Output from RN-41
20	GPIO3	Auto discovery = high	Input to RN-41 with weak pulldown
21	GPIO5	Status, toggles based on state, low on connect	Output from RN-41
22	GPIO4	Set factory defaults	Input to RN-41 with weak pulldown
23	SPI_CSB	Programming only	No connect
24	SPI_MISO	Programming only	No connect
25 - 27	NC	RF pad, keep all traces and planes clear	–
28 - 29	GND	Ground	–
30	AIO0	Optional analog input	Not used
31	GPIO8	Status (RF data RX/TX)	Output from RN-41
32	GPIO9	I/O	Input to RN-41 with weak pulldown
33	GPIO10	I/O (remote DTR signal)	Input to RN-41 with weak pulldown
34	GPIO11	I/O (remote RTS signal)	Input to RN-41 with weak pulldown
35	AIO1	Optional analog input	Not Used

Figure 3 shows the module's physical dimensions.

Figure 3. RN-41/RN-41-N Physical Dimensions

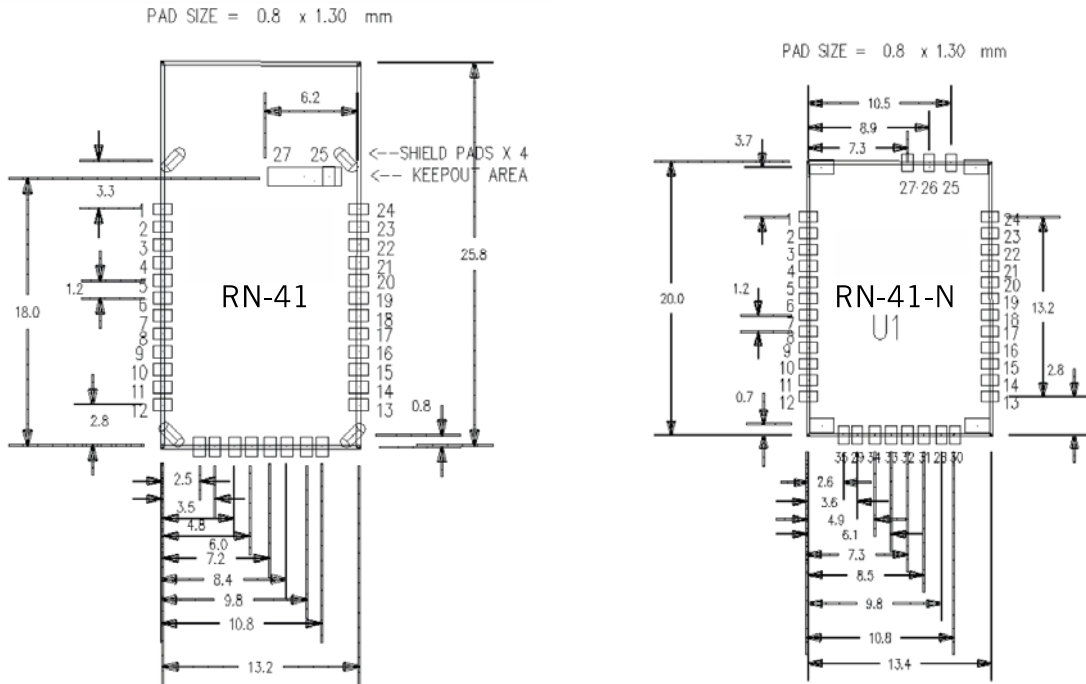

TYPICAL APPLICATION SCHEMATIC

Figure 4 shows a typical application schematic.

Figure 4. Application Schematic

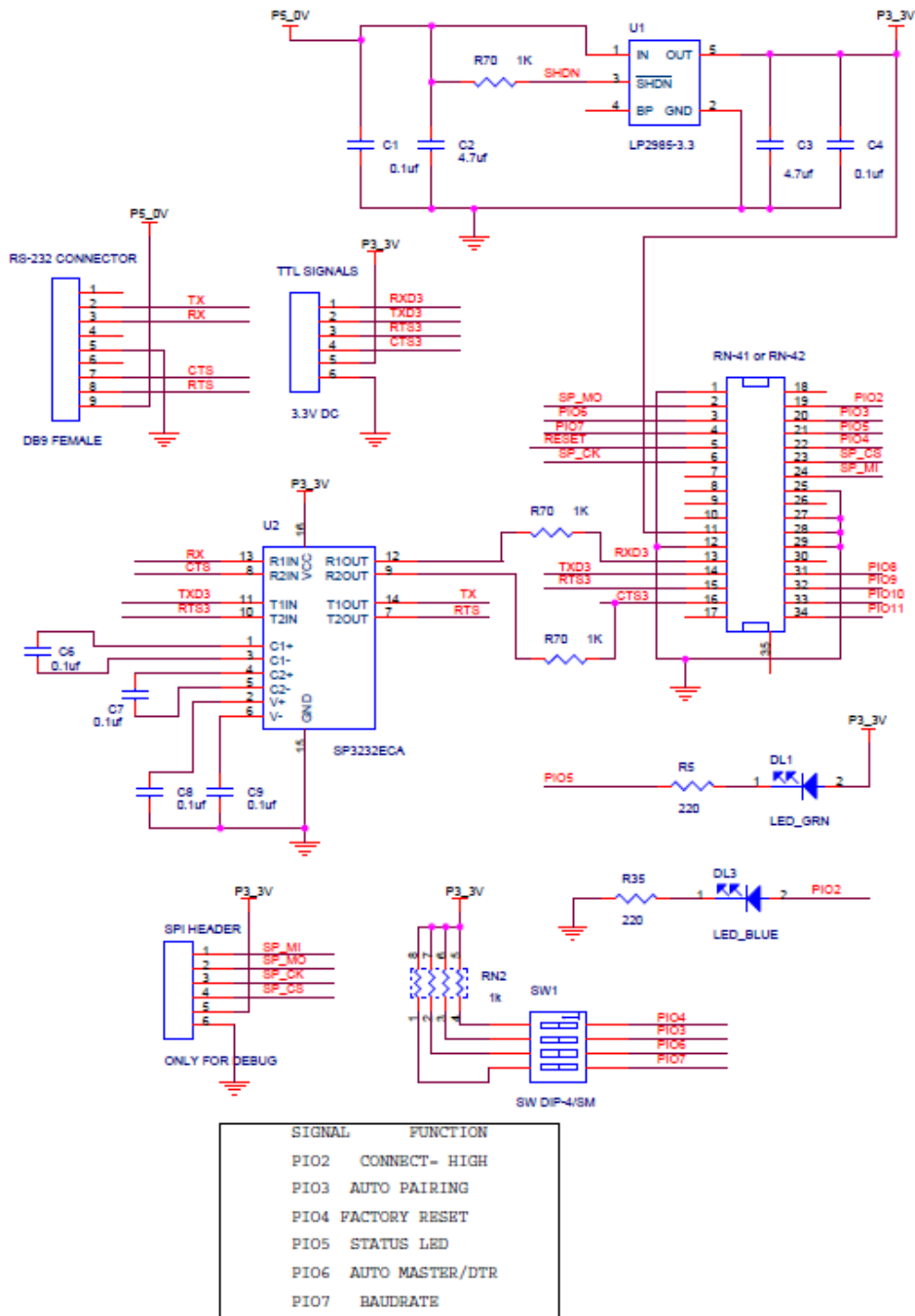

DESIGN CONCERNS

The following sections provide information on designing with the RN-41 module, including radio interference, factory reset, solder reflow profile, connection status, etc.

Reset Circuit

The RN-41 contains a 1k pullup to VCC, and the reset polarity is active low. The module's reset pin has an optional power-on-reset circuit with a delay, which should only be required if the input power supply has a very slow ramp or tends to bounce or have instability on power up. Often a microcontroller or embedded CPU I/O is available to generate the reset once power is stable. If not, designers can use one of the many low-cost power supervisor chips currently available, such as the MCP809, MCP102/121, and Torex XCG1F.

Factory Reset Using GPIO4

Roving Networks recommends that designers connect the GPIO4 pin to a switch, jumper, or resistor so it can be accessed. This pin can be used to reset the module to its factory default settings, which is critical in situations where the module has been misconfigured. To reset the module to the factory defaults, GPIO4 should be high on power-up and then toggle low, high, low, high with a 1 second wait between the transitions.

Connection Status

GPIO5 is available to drive an LED, and it blinks at various speeds to indicate status (see Table 7). GPIO2 is an output that directly reflects the connection state as shown in Table 8.

Table 7. GPIO5 Status

GPIO5 Status	Description
Toggle at 1 Hz	The module is discoverable and waiting for a connection.
Toggle at 10 Hz	The module is in command mode.
High	The module is connected to another device over Bluetooth.

Table 8. GPIO2 Status

GPIO2 Status	Description
High	The module is connected to another device over Bluetooth.
Low	The module is not connected over Bluetooth.

HCI Mode

Roving Networks offers the Host Controller Interface (HCI) mode in addition to the standard operational mode of its Bluetooth modules (standard mode refers to the on-board stack running on the module).

In HCI mode, the on-board stack is bypassed and the module is put in a state that runs the Bluetooth baseband. The HCI provides a command reference interface to the baseband controller and the link manager, and provides access to the hardware status and control registers. This interface provides a uniform method for accessing the Bluetooth baseband capabilities.

In this mode, the Bluetooth stack is no longer on-board the module. It is offloaded to the interfacing host processor. The Bluetooth module is used as a radio, performing the lower level MAC functionalities, while the application stack runs on the host processor.

Using the module in HCI mode allows designers to implement profiles that are not natively supported on the Bluetooth module.

NOTE: HCI mode requires a separate firmware build that must be loaded into the module's flash at the factory. Is not upgradeable in the field.

Roving Networks offers HCI mode in two hardware interfaces:

- HCI over UART
- HCI over USB

HCI over UART

In this mode, the hardware interface between the host processor and the Bluetooth module is the UART. You must interface the flow control signals between the host processor and the Bluetooth module for the HCI interface to work. Failure to do so can cause the host processor and the Bluetooth module to become out of sync and break the Bluetooth link.

HCI over USB

In this mode, the hardware interface between the host processor and the Bluetooth module is the USB. In this architecture, the Bluetooth module is the USB slave and the host processor is the USB host.

Using the USB interface offers the advantage of a faster data link between the Bluetooth module and the host processor. With this architecture, it is possible to achieve Bluetooth's theoretical maximum throughput of 3 Mbps.

Using the SPI Bus to Upgrade the Flash Memory

While not required, this bus is very useful for configuring the Bluetooth modules' advanced parameters. The bus is required when upgrading the module's firmware. The typical application schematic shown in Figure 4 shows a 6-pin header that can be implemented to gain access to this bus. A minimum-mode version might simply use the SPI signals (4 pins) and obtain ground and VCC from elsewhere in the design.

Minimizing Radio Interference

When laying out the carrier board for the RN-41 module, the areas under the antenna and shielding connections should not have surface traces, ground planes, or exposed vias (see Figure 5). For optimal radio performance, the RN-41 module's antenna end should protrude at least 5 mm beyond any metal enclosure.

Figure 5. Minimizing Radio Interference

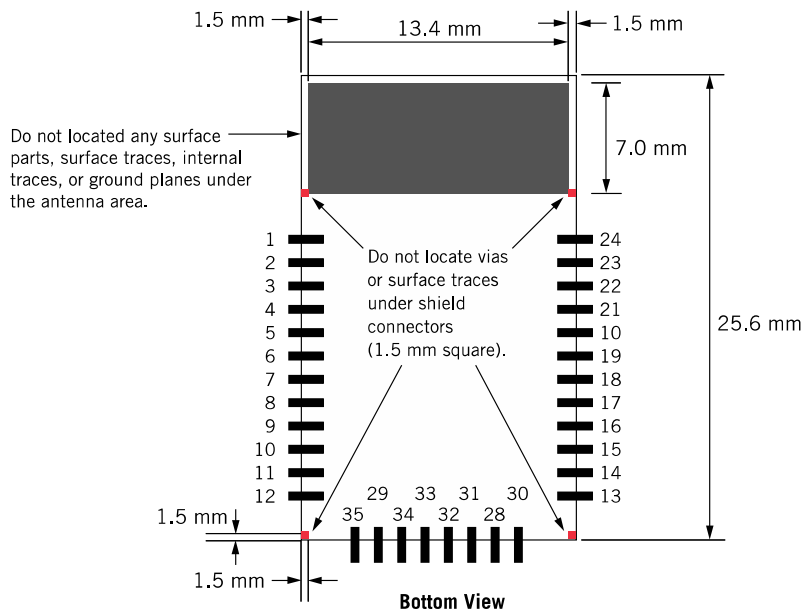

Because the RN-41-N does not contain an antenna, it does not carry regulatory approvals.

If designers use Roving Networks recommended design, they can file for a permissible antenna change and use Roving Networks' regulatory approvals. Roving Networks recommends the Yageo chip antenna for the RN-41-N module. For detailed information on this antenna, refer to the Yageo chip antenna data sheet on the Support page of the Roving Networks website at http://www.rovingnetworks.com/Support_Overview.

If designers choose to use another antenna, they must go through the regulatory approval process.

Solder Reflow Profile

The lead-free solder reflow temperature and times are:

- *Temperature*—230° C, 30 - 40 seconds, peak 250° C maximum
- *Preheat temperature*—165° ± 15° C, 90 to 120 seconds
- *Time*—Single pass, one time

COMPLIANCE INFORMATION

Table 9 describes the module's compliance information.

Table 9. Compliance Information (RN-41 Only)

Category	Country	Standard
Radio	USA FCC ID:	FCC CFR47 Part 15 C, para 15.247
		T9J-R41-1
	Europe	EN 300 328-1
		EN 300 328-2 2.4GHz
	Canada IC Canada ID:	IC RSS-210 low power comm. device 6514A-RN411
EMC	USA	FCC CFR47 Part 15 subclass B
	Europe	EN 55022 Class B radiated
		EN61000-4-2 ESD immunity
		EN61000-4-3 radiated field
		EN61000-4-6 RF immunity
		EN61000-4-8 power magnetic immunity
Bluetooth	LISTED	B013180
Environmental	RoHS	RoHS compliant

ORDERING INFORMATION

Table 10 provides ordering information.

Table 10. Ordering Information

Part Number	Description
RN-41	Standard Application firmware (SPP/DUN Master and Slave).
RN-41-HCI	HCI firmware (HCI over H4 UART).
RN-41-USB	USB firmware (HCI over USB port, slave device at 12-Mbps rate).
RN-41-HID	HID firmware supporting HID device and SPP profiles.
RN-41-N	Standard application firmware (SPP and DUN) without antenna.
RN-41-N-HCI	HCI firmware (HCI over H4 UART) without antenna.
RN-41-N-USB	USB firmware (HCI over USB port, slave device at 12-Mbps rate) without antenna.
RN-41-N-HID	HID firmware supporting HID device and SPP profiles without antenna.
For other configurations, contact Roving Networks directly.	



Go to <http://www.rovingnetworks.com> for current pricing and a list of distributors carrying Roving Networks products.

Federal Communication Commission Interference Statement

This equipment has been tested and found to comply with the limits for a Class B digital device, pursuant to Part 15 of the FCC Rules. These limits are designed to provide reasonable protection against harmful interference in a residential installation.

This equipment generates, uses and can radiate radio frequency energy and, if not installed and used in accordance with the instructions, may cause harmful interference to radio communications. However, there is no guarantee that interference will not occur in a particular installation. If this equipment does cause harmful interference to radio or television reception, which can be determined by turning the equipment off and on, the user is encouraged to try to correct the interference by one of the following measures:

- . Reorient or relocate the receiving antenna.
- . Increase the separation between the equipment and receiver.
- . Connect the equipment into an outlet on a circuit different from that to which the receiver is connected.
- . Consult the dealer or an experienced radio/TV technician for help.

FCC Caution: To assure continued compliance, any changes or modifications not expressly approved by the party responsible for compliance could void the user's authority to operate this equipment. (Example - use only shielded interface cables when connecting to computer or peripheral devices).

End Product Labeling

This transmitter module is authorized only for use in devices where the antenna may be installed such that 20 cm may be maintained between the antenna and users. The final end product must be labeled in visible area with the following: "Contains FCC ID: OA3-RA41N "

"

End Product Manual Information

The user manual for end users must include the following information in a prominent location "IMPORTANT NOTE: To comply with FCC RF exposure compliance requirements, the antenna used for this transmitter must be installed to provide a separation distance of at least 20cm from all persons and must not be colocated or operating in conjunction with any other antenna or transmitter." This device complies with part 15 of the FCC rules. Operation is subject to the following two conditions (1) This device may not cause harmful interference and (2) This device must accept any interference received, including interference that may cause undesired operation.

IMPORTANT NOTE: In the event that these conditions can not be met (for example certain laptop configurations or colocation with another transmitter), then the FCC authorization is no longer considered valid and the FCC ID can not be used on the final product. In these circumstances, the OEM integrator will be responsible for reevaluating the end product (including the transmitter) and obtaining a separate FCC authorization. This device is intended only for OEM integrators under the following conditions: The antenna must be installed such that 20 cm is maintained between the antenna and users. As long as a condition above is met, further transmitter test will not be required. However, the OEM integrator is still responsible for testing their end product for any additional compliance requirements required with this module installed (for example, digital device emissions, PC peripheral requirements, etc.).

This device complies with Part 15 of the FCC Rules and Canada licence-exempt RSS-210 standard. Operation is subject to the following two conditions:

OPERATIONS IS SUBJECT TO THE FOLLOWING TWO CONDITIONS:

- (1) THIS DEVICE MAY NOT CAUSE HARMFUL INTERFERENCE
- (2) THIS DEVICE MUST ACCEPT ANY INTERFERENCE RECEIVED, INCLUDING INTERFEERENCE THAT MAY UNDESIRE OPERATION.

Roving Networks, Inc.
102 Cooper Court
Los Gatos, CA 95032
+1 (408) 395-5300
www.rovingnetworks.com

Copyright © 2012 Roving Networks. All rights reserved. Roving Networks is a registered trademark of Roving Networks. Apple Inc., iPhone, iPad, iTunes, Made for iPhone are registered trademarks of Apple Computer.

Roving Networks reserves the right to make corrections, modifications, and other changes to its products, documentation and services at any time. Customers should obtain the latest relevant information before placing orders and should verify that such information is current and complete.

Roving Networks assumes no liability for applications assistance or customer's product design. Customers are responsible for their products and applications which use Roving Networks components. To minimize customer product risks, customers should provide adequate design and operating safeguards.

Roving Networks products are not authorized for use in safety-critical applications (such as life support) where a failure of the Roving Networks product would reasonably be expected to cause severe personal injury or death, unless officers of the parties have executed an agreement specifically governing such use.