

# **BR5811b User's Manual**

## **802.11A Carrier-Grade Weatherproof Wireless Outdoor Bridge System**

**Document No.: 50-5000(REV:0.3)**

**July 14, 2004.**

**FCC ID: MAD-XXXX**



## Revision History

---

Revision	Date of Issue	Scope	Author
0.1	June 28, 2004	First draft	Carl Yang
0.2	June 30, 2004		Carl Yang
0.3	July 14, 2004		Carl Yang



### FCC Notice:

This equipment has been tested and found to comply with the limits for a Class B digital device, pursuant to Part 15 of the FCC Rules. These limits are designed to provide reasonable protection against harmful interference in a residential installation. This equipment generates, uses and can radiate radio frequency energy and, if not installed and used in accordance with the instructions, may cause harmful interference to radio communications. However, there is no guarantee that interference will not occur in a particular installation. If this equipment does cause harmful interference to radio or television reception, which can be determined by turning the equipment off and on, the user is encouraged to try to correct the interference by one or more of the following measures:

- Reorient or relocate the receiving antenna.
- Increase the separation between the equipment and receiver.
- Connect the equipment into an outlet on a circuit different from that to which the receiver is connected.
- Consult the dealer or an experienced radio/TV technician for help.

Changes or modifications not expressly approved by the party responsible for compliance could void the user's authority to operate the equipment.

This device and its antenna(s) must not be co-located or operating in conjunction with any other antenna or transmitter.

Because standard antenna-connectors are used, this device is for professional installation only.

For the safety reason, people should not work in a location where the RF Exposure exceeds the limits. To get this, people who work with the antennas should be aware of the following rules:

- 1). When using the 8dbi or the 17dbi antenna, the user should keep at least 20 cm or more separation distance with the antenna.

- 2). When using the 23dbi antenna, the user should keep at least 30 cm or more separation distance with the antenna.

## **Disclaimer**

---

**MTI BR5811b Weatherproof Wireless Outdoor Bridge System User' s Manual**

**Document No.: 50-5000(REV:0.35), November 13, 2003.**

**COPYRIGHT ©2003 by Microelectronics Technology INC.**

**ALL RIGHTS RESERVED**

**No part of the publication may be reproduced, transmitted, transcribed, stored in a retrieval system, or translated into any language or computer language, in any form or any means, electronic, magnetic, chemical, manual or otherwise, without the prior written permission of Microelectronics Technology Inc. (MTI). No.1, Innovation RD II, Hsinchu Science-Based Industrial Park, Hsinchu 300, Taiwan, R.O.C.**

**MTI BR5811b is a registered trademark of Microelectronics Technology Inc.**

**Printed in the Taiwan, R.O.C.**

**The instructions in this manual have been carefully checked for accuracy and are presumed to be reliable. The accuracy and adequacy of this document are the responsibilities of Microelectronics Technology Inc. Please address any comments or corrections to Microelectronics Technology Inc.**

## Warranty

---

This Microelectronics Technology Inc. product is warranted against defects in materials and workmanship for a period of one year from date of shipment. During the warranty period, Microelectronics Technology Inc. will, at its option, either repair or replace products which to be defective.

For warranty service or repair, this product must be returned to a service facility designated by MTI. Buyer shall prepay shipping charges to MTI and MTI shall pay shipping charges to return the product to Buyer. However, Buyer shall pay all shipping charges, duties, and taxes for products returned to MTI from another country.

MTI warrants that its software and firmware designated by MTI for use with our product will execute its programming instructions when properly installed on this product. MTI does not warrant that the operation of the product, or software, or firmware will be uninterrupted or error free.

## Limitation of Warranty

---

The foregoing warranty shall not apply to defects resulting from improper or inadequate maintenance by Buyer, Buyer-supplied software or interfacing, unauthorized modification or misuse, operation outside of the environment specifications for this product, or improper site preparation or maintenance.

No other warranty is expressed or implied. MTI specifically disclaims the implied warranties of merchantability and fitness for a particular purpose.

## Trademark Disclosures

---

MTI has made every effort to provide disclosures when using trademarks owned by other companies. Trademarked designations appear throughout this publication. The publisher states that it is using the designations only for editorial purposes, and to the benefit of the trademark owner with no intent to infringe upon that trademark. The following trademarks are found in this manual:

**ATHEROS™** is a registered trademark of Atheros Communications Inc.

## Manual Conventions

---

The following conventions are followed in this manual:

- Bold** Bold type within paragraph text indicates commands, file names, directory names, paths, output, or returned values.
- Italic* Within commands, italics indicate a variable that the user must specify. Titles of manuals or other published documents are also set in italics.
- `Courier` The courier font indicates output or display.
- [ ] Within commands, items enclosed in square brackets are optional parameters or values that the user can choose to specify or omit.
- { } Within commands, items enclosed in braces are options from which the user must choose.
- | Within commands, the vertical bar separates options.
- ... An ellipsis indicates a repetition of preceding parameter.
- > The right angle bracket separates successive menu selection.

### Notices

---

**NOTE:** This message denotes neutral or positive information that calls out important points to the text. A note provides information that applies only in special cases.

---

**Caution:** Cautions call special attention to hazards that can cause system damage or data corruption, to a lesser degree than warnings.

**Warnings:** Warnings call special attention to hazards that can cause system damage, data corruption, personal injury, or death.

Microelectronics Technology Inc. (MTI) is very pleased for you purchase in this product. MTI BR5811b is a cost-effective way to expand or replace your local, wired networks (LANs). With this system, your wired networks can communicate with one another wired networks.

### Building to Building Connection

---

MTI 802.11a wireless outdoor turbo bridge BR5811b is a wireless building-to-building bridge solution. BR5811b provides data rate up to 108 Mbps and is best suited for enterprises, campus or off-site locations that require LAN or Internet access without the availability of wired networks to extend network coverage.

BR5811b provides point-to-point and point-to-multi-point connection capabilities. The wireless building-to-building bridging solution contains a state-of-the-art wireless Bridge, high gain performance 17dBi flat patch antenna and power-over-Ethernet technology. For further protection, the bridge and power-over-Ethernet adapter have built in lightning protector.

### Last Mile Solution

---

MTI's BR5811b provides the alternative solution for last-mile connection. By leveraging the 802.11's volume power and low cost, BR5811b Link provides very cost effective solution to carriers. With the cost effective wireless last mile solution, service provider can have fast deployment (time-to-market) and successful business models.

This document was written for user of the MTI BR5811b Weatherproof Wireless Outdoor Bridge System. First, we will introduction our system, help you to connect it and install the software, and describe the entire feature about the system.

This manual contains information on installing, operating, and maintaining the MTI BR5811b. Installation tasks include mechanical installation of the MTI BR5811b, connecting external equipment to the MTI BR5811b, and configuring the system. Operation tasks include modify operating parameters, monitoring status, and maintaining the system through troubleshooting and system repair procedures. This manual is intended for those people who install and operate the MTI BR5811b system.

### Documentation

---

The accompanying documentation comprises:

Manual - Hardware installation, description of the functions, operating modes and sample configurations

CD containing electronic documentation - Complete set of manuals for the product family, technical basics (such as information on wireless networks, general network technology, TCP/IP etc.), a workshop with detailed descriptions of sample applications, and a reference section including comprehensive description of the menus.

# Table of Contents

---

- Revision History .....2
- Disclaimer.....4
- Warranty .....5
- Limitation of Warranty .....5
- Trademark Disclosures .....5
- Manual Conventions .....6
- PREFACE .....7**
- Building to Building Connection.....7
- Last Mile Solution .....7
- Documentation .....7
- TABLE OF CONTENTS.....8**
- CHAPTER 1 INTRODUCTION..... 10**
- 1-1 System Requirements ..... 10
- 1-2 Product Configurations ..... 10
- 1-3 Specification..... 11
- 1-4 Hardware Architecture ..... 11
- CHAPTER 2 HARDWARE INSTALLATION ..... 13**
- 2-1 Unpacking the Equipment..... 13
- 2-2 Verifying the System Configuration..... 13
- 2-3 Installation Kit..... 13
- 2-4 Grounding ..... 14
- 2-5 ESD Protection ..... 14
- 2-6 Outline of MTI BR5811b..... 15
- 2-7 Installing the ODU ..... 16
- 2-8 Connecting the cable ..... 16



2-9 Align the Antenna (TBD).....	17
<b>CHAPTER 3 BRIDGE NETWORK CONFIGURATION .....</b>	<b>18</b>
3-1 Bridge Network Connections .....	18
3-2 Network Configuration .....	19
3-3 Bridge Initial Configurations .....	20
3-4 Web Browser.....	21
3-5 Bridge Web Server .....	22
3-6 Configuration Windows .....	24
3-7 Working with Configuration Windows .....	24
3-8 System Basic Configuration Window .....	25
3-9 System Advanced Configuration Window .....	26
3-10 Advanced Setup Window.....	27
3-11 Firmware Update Configuration Window .....	27
3-12 Statistics Windows .....	28
3-13 Bridge Statistics .....	28
3-14 Station Statistics .....	30
3-15 Bridge setup window .....	32
<b>APPENDIX A ACRONYMS &amp; ABBREVIATIONS.....</b>	<b>33</b>

## Chapter 1 Introduction

---

MTI 802.11a wireless outdoor turbo bridge, BR5811b is a wireless building-to-building bridge solution, BR5811b provide the data rate up to 108 Mbps that is best suited for enterprises, campus or off-site locations that require LAN or Internet access without the availability of wired networks to extend the network coverage. BR5811b provides the point to point and point to multi-point connection.

The wireless building-to-building bridging solution contains a state of the art wireless Bridge, high gain performance 17dBi flat panel antenna and Power over Ethernet. For further protection, the bridge and Power over Ethernet adapter have build in lightning protector.

Rates of 6 to 54 Mbps are supported in standard IEEE 802.11a modes, and up to 108 Mbps in Atheros Turbo Mode. All 802.11a transmission rates are supported across the 5.15 to 5.85 GHz spectrum.

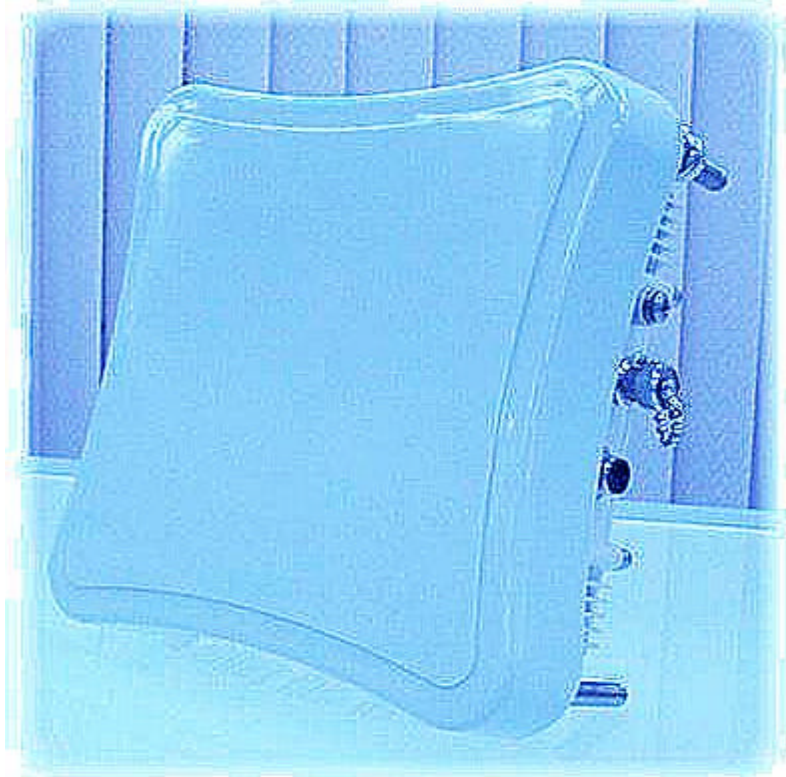

### 1-1 System Requirements

---

The Bridge contains a small boot executive that allows the main operating system software to be downloaded using the Ethernet port over an FTP connection. The Operating system software can also reside in the Flash memory of the Bridge, which allows booting without the need to download the operating system from the host PC over an FTP connection. A configuration file is created in Flash memory to store user-configurable parameters. A terminal or PC with an Ethernet connection is required to perform the initial Bridge configuration. An FTP server is required for firmware update to the Bridge.

### 1-2 Product Configurations

---

The base hardware is an outdoor mountable metal enclosure. The BR5811b can be managed via the network station remotely. The following are available product configurations:

- Fast Ethernet managed 802.11a wireless outdoor turbo bridge
- Outdoor Mounting Kit
- One POE Power Injector

- One POE Ethernet cable
- One POE Power Core
- User's Manual
- CD ROM

## 1-3 Specification

---

### ■ Radio

- Operating Band
  - 5.25 ~ 5.35GHz
  - 5.725 ~ 5.85 GHz
- Operating Channels 9 Channels
- Transmit output power
  - +20 dBm for 6 ~ 36 Mbps
  - +18 dBm for 48 Mbps
  - +16 dBm for 54 Mbps
- Receive Sensitivity
  - 91 dBm for 6Mbps
  - 89 dBm for 12Mbps
  - 87 dBm for 18Mbps
  - 84 dBm for 24Mbps
  - 80 dBm for 36Mbps
  - 75 dBm for 48Mbps
  - 70 dBm for 54Mbps
- Antenna
  - Build in +17dBi Flat Panel
  - External +23dBi Flat Panel
  - External +8dBi Omni Dipole
- Modulation Technology OFDM
- Media Access Technique CSMA/CA

### ■ Environment

- Operating Temperature -33 ~ +55°C
- Storage Temperature -40 ~ +80°C
- Humidity 0 ~ 95%, non-condensing
- Altitude 15,000 feet
- Lightning-Protection Built-In Surge Protection

### ■ Interface

- LAN 10/100 Ethernet Port

### ■ Power

- POE 48V DC, 18W Max

## ■ Physics

- Dimensions 198 x 198 x 63 mm
- Weight <2.0Kg

## ■ Miscellaneous

- Security 128-bit WEP
- Management web-based GUI
- Software Upgrade TFTP
- VPN Pass-through Yes

## 1-4 Hardware Architecture

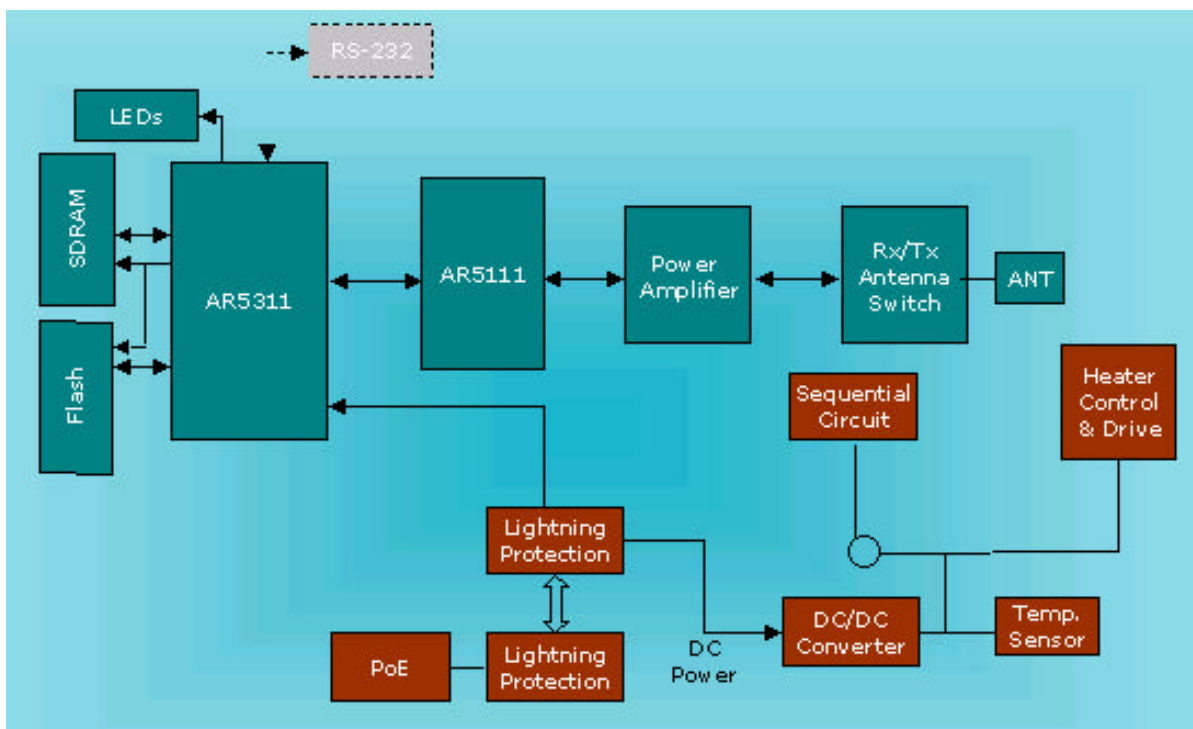

**WARNING:** If end users are allowed to upgrade firmware through the FTP server, confirm that the End User License Agreement (EULA) covers upgrades to the firmware. The Reference Design upgrade code permits direct upgrades of the Bridge from the configuration screen if a web browser is used. As a precaution, also use the EULA as the FTP startup text in the event some end users log in to the FTP server manually.

Use the Bridge Web Server for firmware updates. Refer to “ Firmware Update Configuration Window ” for information on the web server.

## Chapter 2 Hardware Installation

---

This chapter provides installation procedures are generally outlined as follows:

- Verify system configuration
- Installing the ODU
- Installing the POE
- Mounting and alignment the antenna
- Connecting external equipment

You may need to use Web Browser to change or set the MTI BR5811b system's operating parameters. Refer to chapter 3, Bridging network attachment and configuration, for more information.



### 2-1 Unpacking the Equipment

---

The tools required for unpacking the system equipment are:

- Utility knife
- Clean, flat working surface

Open the shipping containers, carefully remove the equipment and place it on a clean, flat working surface. Save the shipping and packing material in case the equipment has to be returned.

Check the equipment and installation kits against the packing list to ensure that the equipment part numbers, parts, and ancillary equipment included in the shipment match what is specified on the packing list. Shipments consist of an ODU and an installation kit in one container. Verify the configuration as described in verifying the System Configuration. If there are discrepancies between the packing list and the equipment received, contact your sales representative.

Inspect the equipment for any type of shipping damage. If any part of the shipment is damaged, contact your sales representative for repair or replacement instructions.

### 2-2 Verifying the System Configuration

---

The MTI BR5811b system consists of an Outdoor Unit (ODU), POE and an installation kit.

### 2-3 Installation Kit

---

Most of the materials needed for installation are supplied with the system. Some tools and equipment must be supplied by the user. Table lists materials in a typical installation kit. Refer to the packing list for a description of the exact contents.

Table Installation Kits (for 2" Steel or Stainless Steel Tube)

Item	Description	Quantity
1	<b>M-TYPE PLATE</b>	1EA
2	<b>L-TYPE PLATE</b>	1EA
3	<b>U-TYPE PLATE</b>	1EA
4	<b>NUT FLANGE M8-1.25 SS (PLATE ASM)</b>	3EA
5	<b>NUT FLANGE M8-1.25 SS (HOUSING ASM)</b>	4EA

## 2-4 Grounding

---

Proper grounding of equipment and structures is essential to prevent electrical damage to the MTI BR5811b system.

Grounding of all equipment at a radio site is required. Without proper grounding, voltage potentials between components of the system can cause electrical damage when interconnecting cables are installed.

It is recommended that the ODU be installed with lightning rod protection. Also, to avoid surge current caused by lightning circulating to the equipment earth system, connect the equipment earth system (true ground) to the lightning rod ground.

Please connect the ground node to the existing ground.

**Note: Ground wires and hardware are not provided in the installation kit.**

## 2-5 ESD Protection

---

ESD (electrostatic discharge) can damage electronic components. Even if components remain functional, ESD can cause latent damage that results in premature failure. Personnel and equipment must be properly grounded. Always wear proper ESD grounding straps during equipment installation, maintenance and repairs. Connect your ESD grounding strap to the ESD connector.

## 2-6 Outline of MTI BR5811b

---

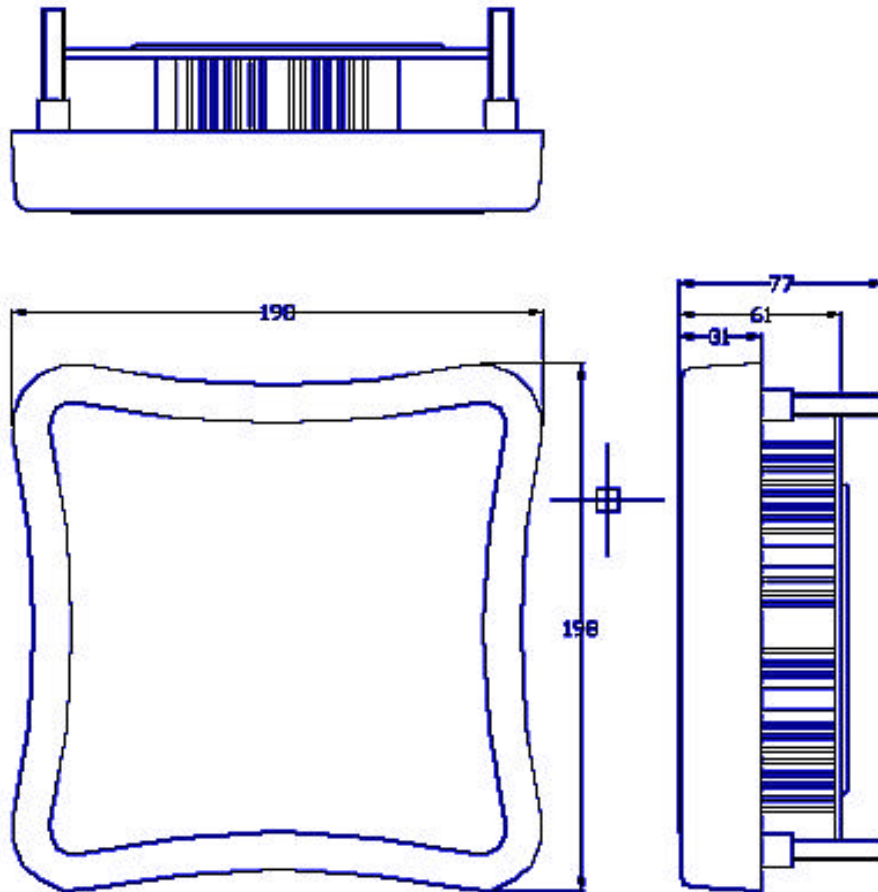

## 2-7 Installing the ODU

---

The MTI BR5811b can be mount on a 2” Steel or Stainless Steel Tube. You can reference the Figure.

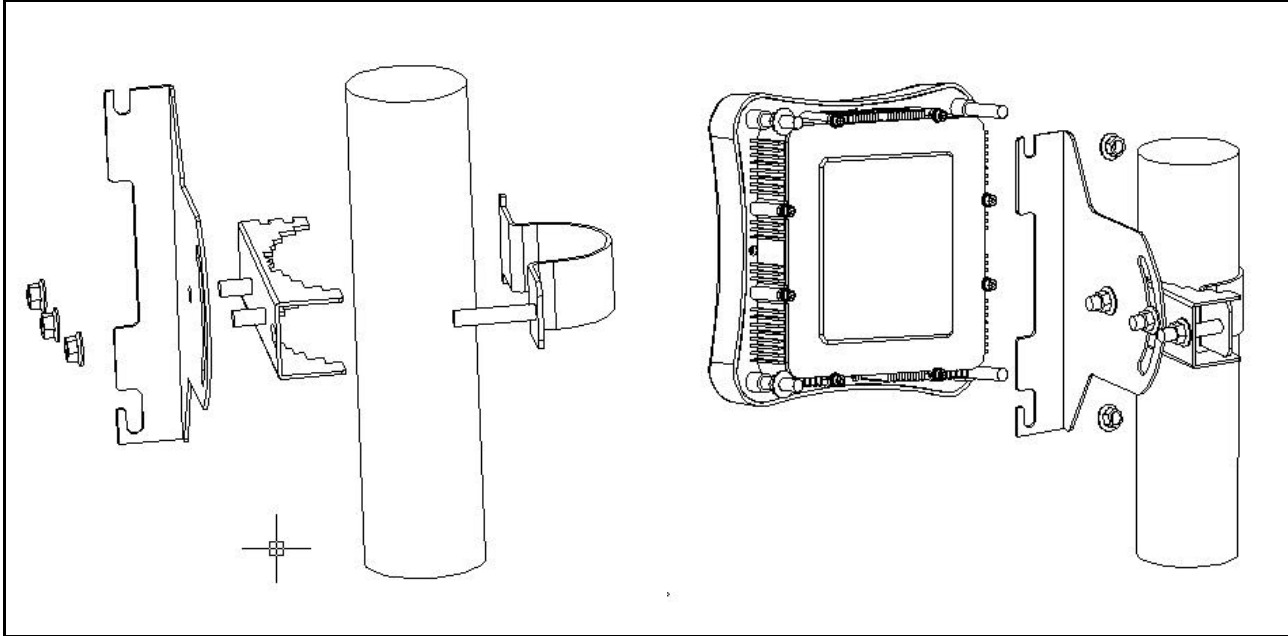

ODU Configuration

You can refer the photo here for installation.

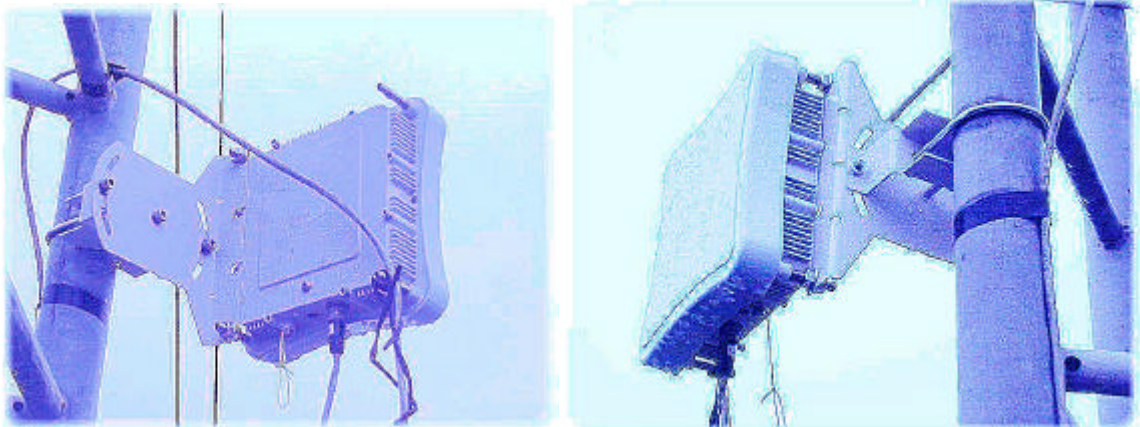

## 2-8 Connecting the cable

---

An Ethernet cable connects the ODU to the POE output port. The cable connects power to the ODU and allows Ethernet data to flow between Stations with Bridge system. Another Ethernet cable connects the station to POE input port. AC power is applied to the bridge system by connect it to POE AC adapter.



## 2-9 Align the Antenna (TBD)

---

Antenna alignment is performed with both the near-end and the far-end terminals operating. The antenna position is adjusted while monitoring the RSSI for antenna alignment voltage. The higher the RSSI voltage reading is, the stronger the signal. The range of the RSSI voltage reading is from 0 to 3.28VDC, and the resolution is 256 divisions.

Caution: To ensure optimum system performance, the main lobe of the antenna must be aligned with the center of the far end antenna. Rotate the antenna through the range of radiated power so the main lobe can be positively identified. Each side lobe is approximately 20 dB lower than the preceding lobe as you move away from the main lobe.

This antenna alignment procedure is applicable to both protected and non-protected system configurations. Align the antenna as follows:

Note: Repeat this procedure if the initial alignment does not produce the correct RSSI reading.

1. Consult your path calculation and adjust the radio 's attenuation level, so do not exceed the maximum receiving signal level.
2. Verify that the Bridge at the far end is operational.
3. At the near-end Bridge, remove the protective cap from the RSSI BNC connector.
4. Connect a voltmeter to the RSSI connector and set the voltmeter to measure VDC.
5. Pivot the antenna slowly in the azimuth direction. Monitor the voltmeter and locate the position where the voltage is minimum (null) and record the reading.
6. Monitor the voltmeter and pivot the antenna in the elevation direction. Pivot the antenna to the position where the voltage is minimum on the voltmeter and record the reading.
7. Repeat these steps as necessary to get an accurate reading.
8. Tighten all fasteners and check that the null has not changed. If the null has changed, repeat the procedure until the null is maintained after tightening the fasteners.
9. Disconnect the voltmeter and replace the RSSI protective cap.

Note: The signal level over the link is not optimal until both antennas are correctly aligned.

## Chapter 3 Bridge Network Configuration

This chapter provides procedures for connecting and configuring the Bridge to a Host PC (HPC). Configuration can be performed either from a web browser accessing the built-in web server. For detailed information on using the web server, refer to “ Bridge Web Server ” .

### 3-1 Bridge Network Connections

Connect the HPC to the Bridge using one of the following two methods:

- Use an Ethernet crossover cable (not supplied) to connect directly to the Ethernet port of the HPC. For more information on Ethernet cables, see Table.

Table Ethernet Port Configuration

Ethernet Port Number	Dumb Hub or Switch	Computer	Auto-Sensing Hub or Switch
0	Crossover cable	Straight cable	Crossover or straight cable
1	Straight cable	Crossover cable	Crossover or straight cable

- Use standard Ethernet cables (not supplied) to connect through a hub or Ethernet switch. See Figure for an example of the Bridge to the HPC connections.

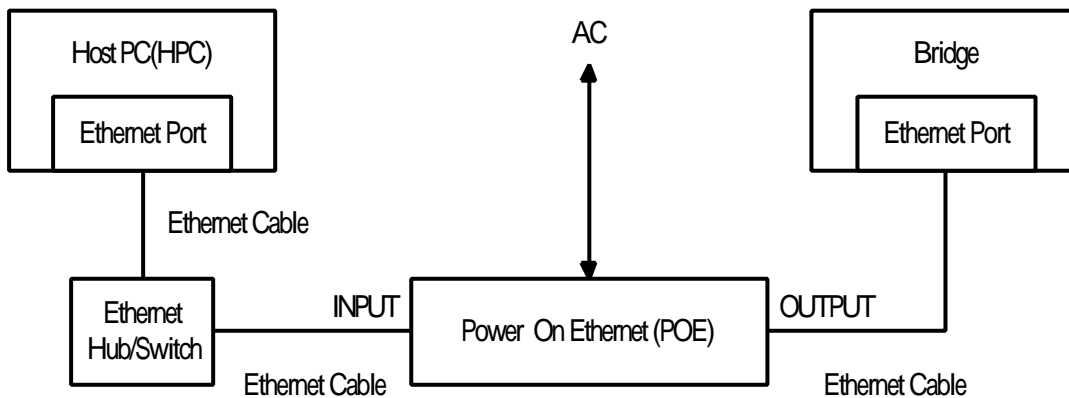

Bridge to the HPC connection

To establish the network connections, connect the Bridge Ethernet port to the HPC Ethernet card through the Ethernet hub/switch or an Ethernet crossover cable.

## 3-2 Network Configuration

---

Follow these steps to configure the HPC for Bridge network control:

- From the HPC 's Start menu, choose Settings and open the Network and Dial-up Connections dialog box.
- Right-click on the Local Area Connection icon that belongs to the Ethernet controller connected to the Bridge, and select Properties.
- Within the Local Area Connection Properties dialog box, choose Internet Protocol (TCP/IP) and click Properties.

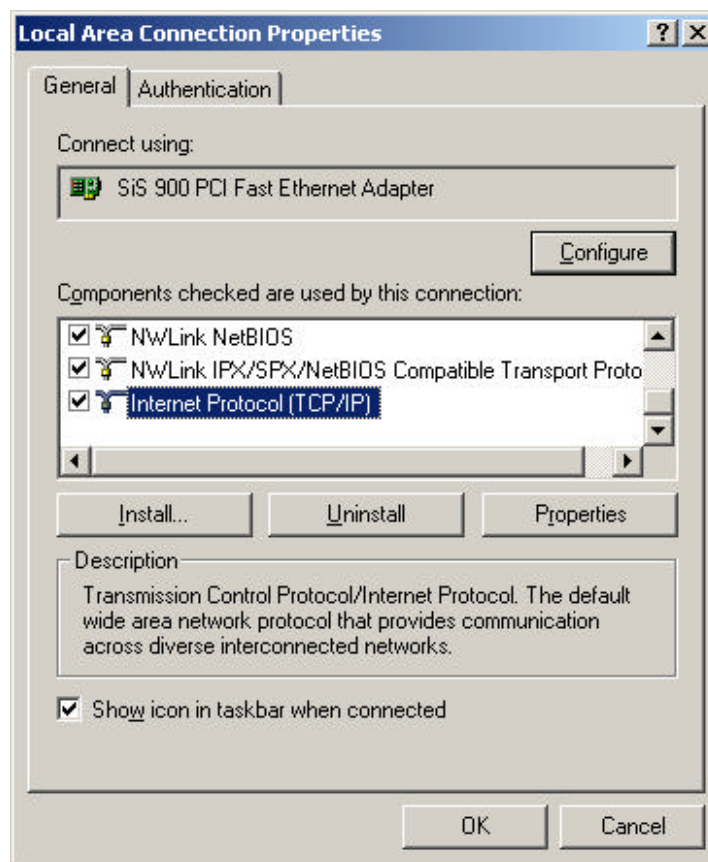

Local Area connection properties window

- Configure the following setting for the Ethernet connection in the Internet Protocol (TCP/IP) Properties dialog box.
  - User IP Address (Don't use the same IP address as your bridge)
  - LAN Mask Setting
  - Gateway Setting
  - DNS Server Setting

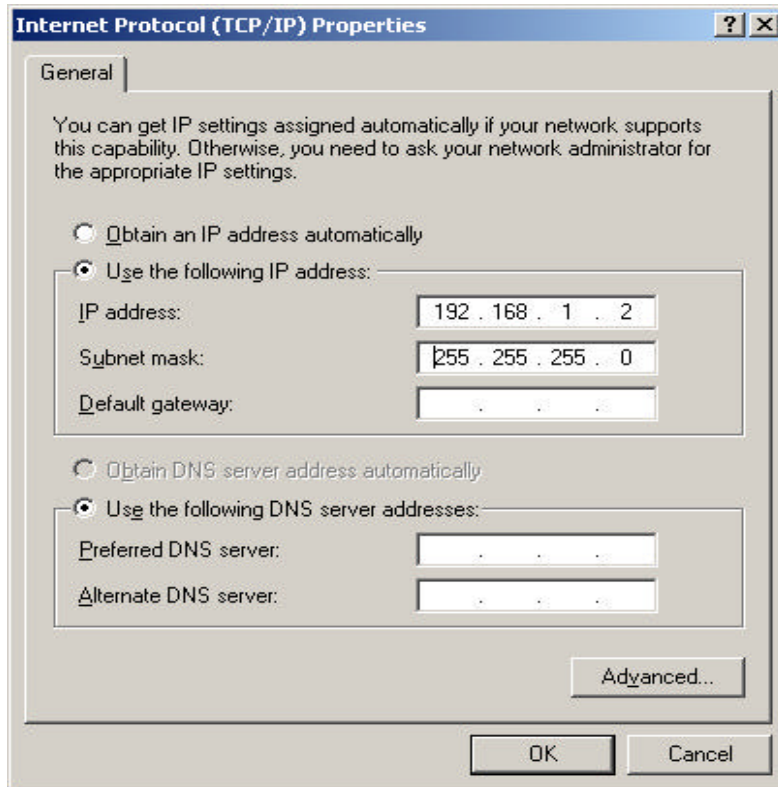

Internet protocol (TCP/IP) Properties dialog box

- Click OK to continue and close the Internet Protocol Properties dialog

## Notices

---

If you use the same HPC to ping/connect the same IP bridges, you must clear the route table in the HPC first. Otherwise, you won't find other bridge. In Microsoft Windows system, you can do it by enter following command in DOS command mode: (assume the ARP program is under the path of c:\windows\system32)

```
C:\windows\system32>ARP -D
```

---

## 3-3 Bridge Initial Configurations

---

This section describes how to configure the Bridge after booting from Flash memory. Refer to “ Firmware Update Configuration Window ” to load the Operating image file to the Flash file system, if the operating system software should be updated.

Configure the Bridge for its channel frequency and Service Set Identifier (SSID) unique to the application. This configuration can be done either through a web browser with access to the built-in Bridge web server. The Bridge can be configured at any time to tailor it for the application environment. For more information on configuring the Bridge using the web browser, refer to “ Bridge Web Server ” . The following description illustrates the use of the web browser

## 3-4 Web Browser

---

Follow these steps to configure the channel frequency and SSID using a web browser:

- Launch a web browser (Netscape Navigator or Internet Explorer are examples of commonly used web browsers).
- From the HPC, enter the IP address that is assigned to the Bridge as the URL address, for example **http://192.168.1.1**.

The Bridge Web Server homepage will appear (see Figure).

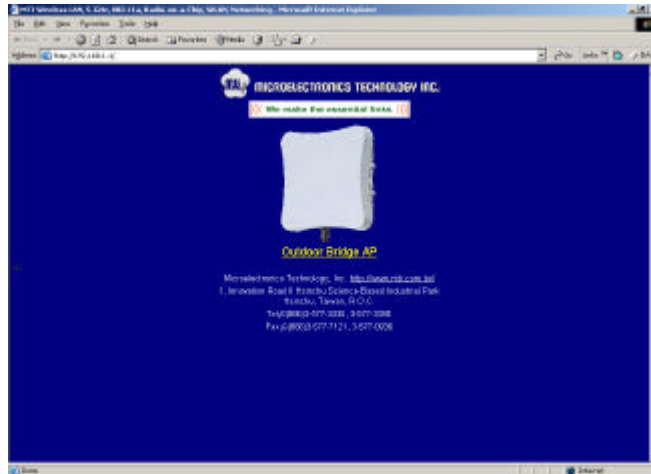

BRIDGE Web Server Homepage

- Select the Bridge Web Server hotlink.
- A dialog box appears requesting login authorization. When prompted, enter the following information to log in:

Log in: **Admin** (case-sensitive)

Password: **5up**

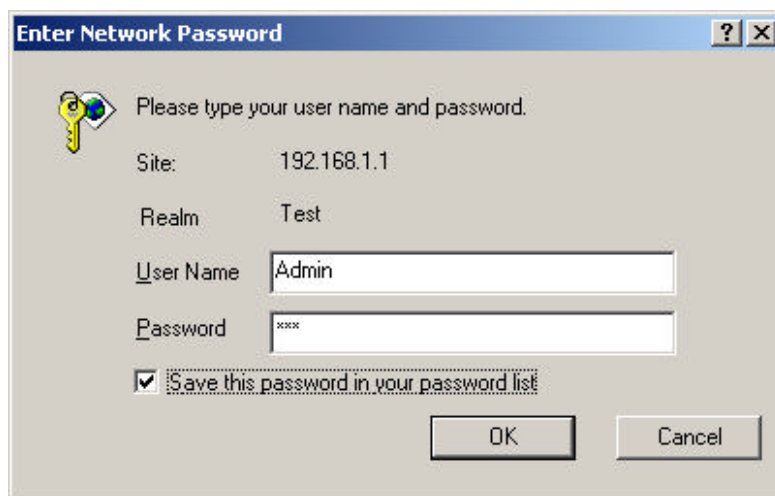

- Click OK to complete the login process. The Basic Configuration window appears (see Figure).

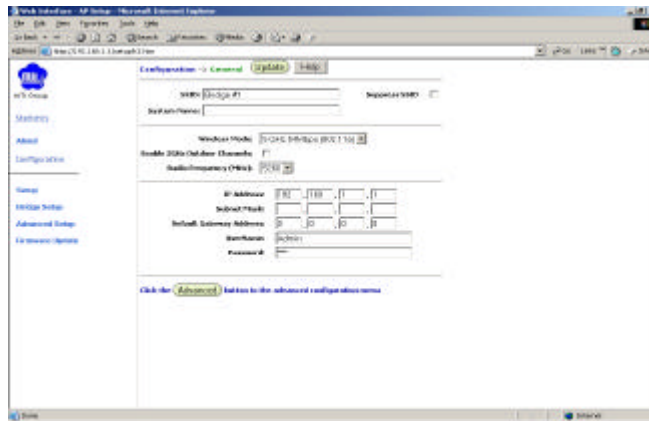

System Basic Configuration Window

- Enter the SSID (name or address) for the Bridge in the SSID field. The SSID must be 1 – 32 characters in length. To configure a single SSID to have more than one Bridge in a single SSID, specify a unique System Name for each Bridge within that single SSID.
- Specify the radio frequency operation of the Bridge by selecting the desired value from the Radio Channel drop-down menu. This value specifies the frequency the stations (STAs) under the Bridge are associating with in Infrastructure mode.
- Note that the radio channel is specified using the IEEE 802.11a standard.
- Click Update to commit the changes.



Change other settings at this time. After all configuration changes are complete; reboot the Bridge to enable them. To reboot the Bridge, click on the REBOOT Bridge button that appears.

**Reminder: Click the  buttons for changes to take effect.**

### 3-5 Bridge Web Server

---

Configure the Bridge either through a web browser interface to the Bridge web server. The web server resides in the Bridge and is accessible from any station (STA) that is connected to the Bridge Infrastructure network.

#### Accessing the Bridge Web Server

Follow these steps to access the Bridge Web Server:

- Launch a web browser (Netscape Navigator or Internet Explorer are examples of commonly used web browsers).
- From the HPC, enter the IP address that is assigned to the Bridge as the URL address. For example, enter **http://192.168.1.1**.

The Bridge Web Server homepage appears (see Figure).

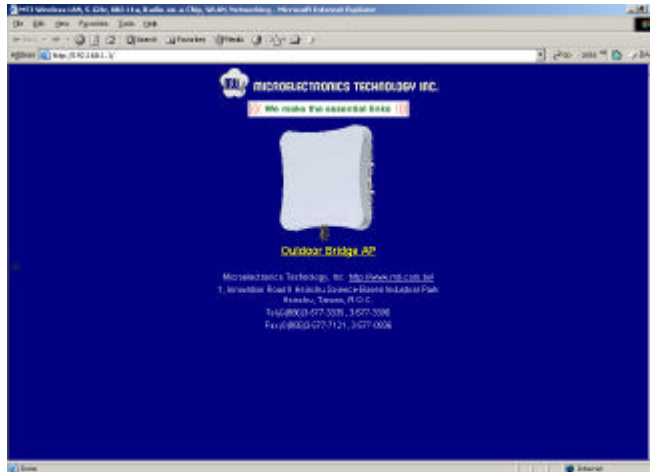

Bridge Web Server Homepage

- Select the MTI Outdoor Bridge Web Server hotlink.
- A dialog box appears requesting login authorization. When prompted, enter the following information to log in:  
Log in: **Admin** (case sensitive)  
Password: **5up**



- Click OK to complete the login process.

---

**NOTE:** The web browser must support frames and Java script must be enabled.

---

The Bridge Web Server Basic Configuration window appears (see Figure.)

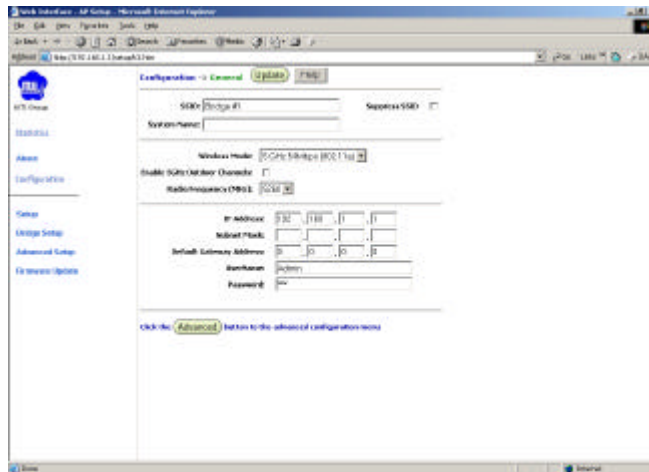

Basic Configuration Window

### 3-6 Configuration Windows

The Web Server Configuration windows allow viewing and editing of configuration information for the Bridge. The Web Server provides configuration windows for:

- System configuration parameters
- Radio configuration parameters
- Statistics
- Firmware updates

- Statistics
- About
- Configuration

---

- Setup
- Bridge Setup
- Advanced Setup
- Firmware Update

To access any of these Bridge configuration screens, click on the desired hotlink from the navigation bar on any configuration screen (see Figure)

### 3-7 Working with Configuration Windows

The Web Server Configuration windows provide a user-friendly interface to aid in quick configuration of the Bridge. After making any additions or changes to any configuration window, update the configuration file to save the changes. The new configuration is not in effect until the Bridge is rebooted.

Follow these steps to update configuration files:

- Enter the configuration updates or changes in the appropriate configuration fields.
- Click Update. 
- Click Reboot Bridge to make the changes effective.

**Reminder: Click the  buttons for changes to take effect.**

The web server loses connectivity with the Web Server as the Bridge reboots.

To reestablish the connection with the Web Server, wait until the Bridge has completed rebooting and navigate to the Web Server to resume communication.



## 3-8 System Basic Configuration Window

The System Basic Configuration window allows the setting of general operating information for the Bridge. Click on Configuration from any window to access the System Basic Configuration window (see Figure).

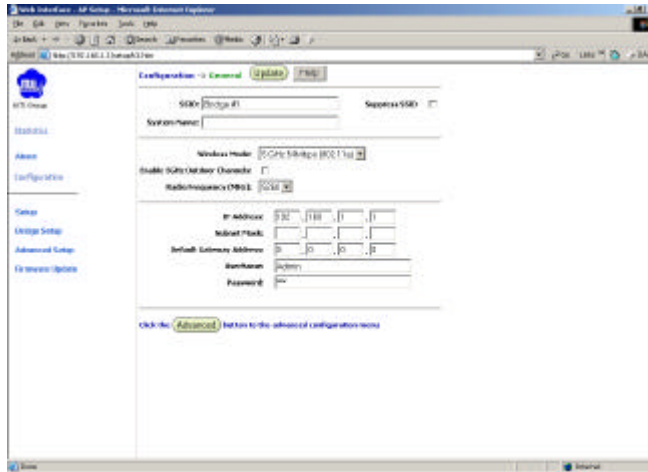

Bridge System Basic Configuration Window

Set the value of default gateway address to PC IP or router port IP.

Other settings can also be changed at this time.

Table A-2 summarizes the data fields on the System Basic Configuration window.

Table A-2. System Basic Configuration Window Field Descriptions

General Configuration Field	Description
SSID	Identification of the Bridge. Enter a number or address between 1 and 32 characters in length that the STAs are associating with in Infrastructure mode. More than one Bridge in an SSID can be specified here. Use the System Name field to uniquely identify each Bridge.
Suppress SSID	Use the checkbox to prevent broadcast of the Bridge 's SSID in beacons. When enabled, the SSID in beacons are not transmitted and only those STAs with prior knowledge of an Bridge 's SSID can associate with that Bridge.
System Name	Specifies a unique name for Bridge. Enter a unique text string of up to 32 characters in length. Both bridge A and B must have the same system name.
Wireless Mode	The wireless LAN mode specifies both frequency range and data rates.
Enable 5GHz Outdoor Channels	Click this button to Enable 5GHz radio operation
Radio Frequency (MHz)	Select the desired frequency of operation from the drop-down menu. The radio frequencies that appear in the Radio Channel drop-down menu are dependent on the wireless mode selection.
IP Address	Specifies the IP address of the Bridge.
Subnet Mask	Specifies the subnet mask for the Bridge.
Default Gateway Address	Specifies the default gateway for the Bridge.
User Name	Specifies the user name.
Password	Specifies the password.

## 3-9 System Advanced Configuration Window

The System Advanced Configuration window allows the setting of detail operating information for the Bridge. Click on **Advanced** button from any window to access the System Advanced Configuration window (see Figure below).

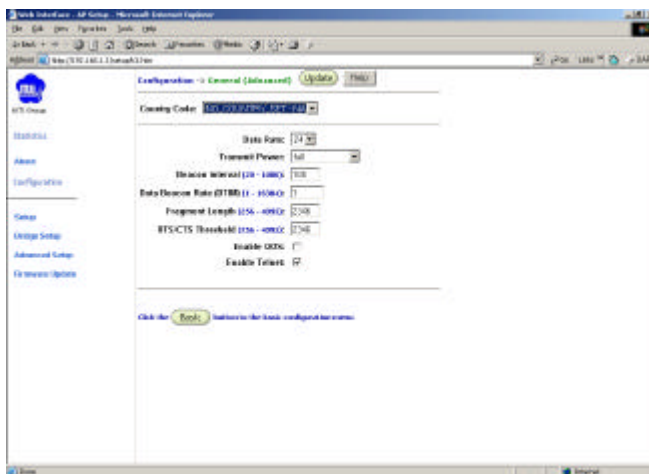

Table summarizes the data fields on the Radio Advanced Configuration window.

Table Radio Advanced Configuration Window Field Descriptions

Advanced Configuration Field	Description
Data Rate	Specifies rate of data transmission. Select the desired rate from the drop-down menu. The Best selection will adapt the rate to the best available.
Transmit Power	Specifies the level of transmit power. Choose the value of the transmit power from the dropdown menu. Decrease the transmit power if more than one AP is co-located using the same channel frequency.
Beacon Interval	Specifies the Beacon Interval value. Enter a value between 20 and 1000.
Data Beacon Rate	Specifies the Data Beacon Rate. Enter a value between 1 and 16384 that specifies the Delivery Traffic Indication Message (DTIM).
Fragment Length	Specifies the fragment length. Enter a value between 256 and 2346.
RTS/CTS Threshold	Specifies the value of the RTS/CTS threshold. Enter a value between 256 and 2346.

### 3-10 Advanced Setup Window

The Advanced Setup Window let you setup the distance between two bridges to make the traffic more efficiency. See the following figure for Advance Setup Window.

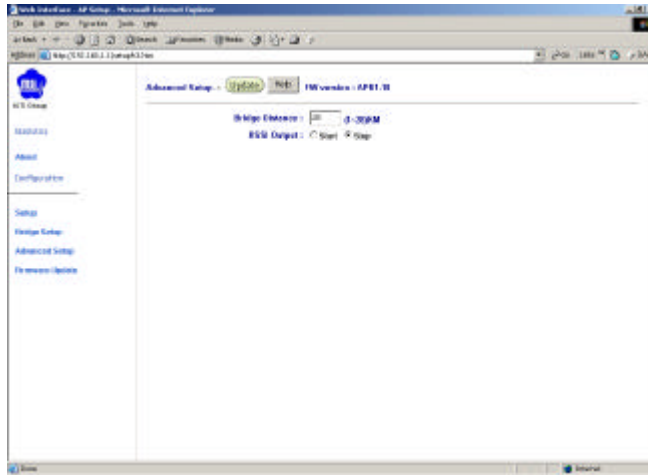

Bridge System Advance Setup Window

**NOTE:** Select the distance between both bridges used in point to point connection. It's not necessary to select exact distance value in this input, but using a value bigger than actual value is most important. A smaller value selected may cause link fail.

### 3-11 Firmware Update Configuration Window

The Firmware Update Basic Configuration window allows viewing of the FTP location of new firmware. The default values for the Host Name, Image Path, and Image Name appear in the window.

To access the Firmware Update window, click on Firmware Update in the navigation bar. The Firmware Update Configuration Window appears (see Figure).

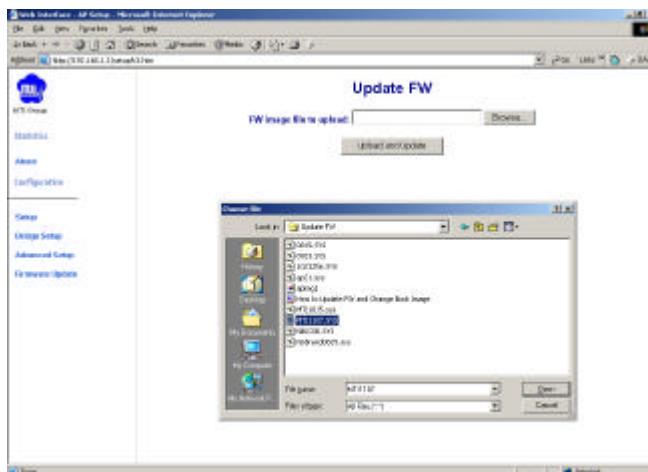

Bridge Firmware Update Configuration Window

Bridge uses the File Transfer Protocol (FTP) to download the Operating image from the HPC. An FTP server utility is required to perform the data transfer between the Bridge and HPC.

### 3-12 Statistics Windows

From the Bridge Web Server, choose the Statistics hyperlink to go to the Bridge Statistics window. By default, this is the first window that appears once the Bridge Web Server opens.

The Bridge Statistics window allows viewing of the assigned ID, MAC address, and current state of the Bridge and all stations currently part of its BSS (Basic Service Set). The top-level Statistics window automatically updates each minute.

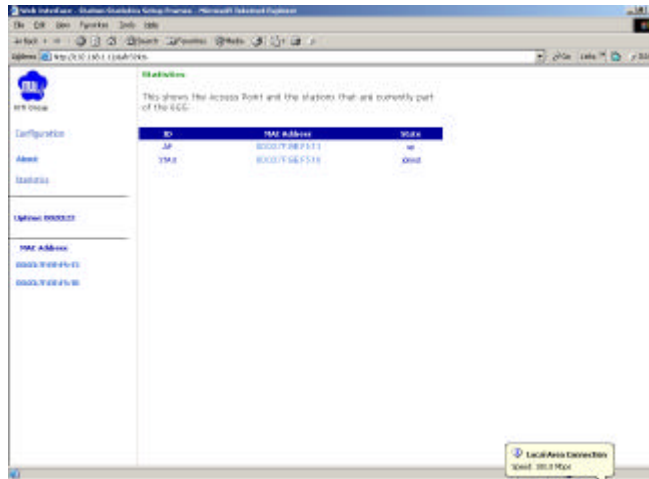

### 3-13 Bridge Statistics

To view statistics on the Bridge, click on the MAC address hyperlink for the desired Bridge in the Statistics window. The BSS Stats window for the selected Bridge will appear. See Figure for an example of a BSS Stats window for a Bridge.

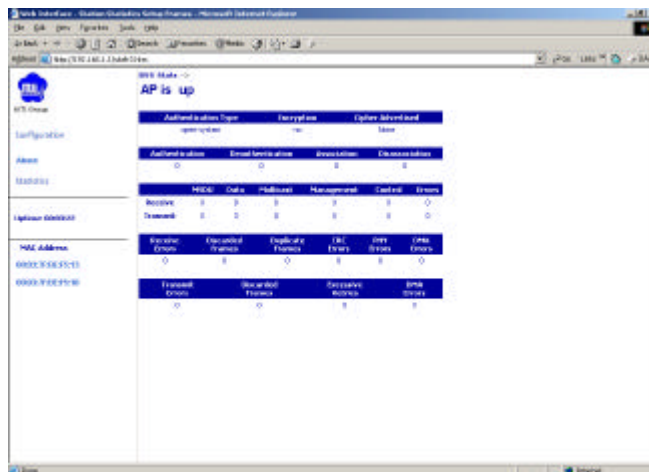

Basic Service Set Statistics Window for an Bridge

The BSS Stats window for Bridge is divided into sections that provide the Bridge configuration, Bridge SME statistics (station association information), or Bridge (Transmit and Receive) Statistics. Refer to Table for a description of the BSS Statistics for Bridge window fields.

Table. BSS Stats Field for Bridge Descriptions

BSS Stats Field	Description
State	Current state of the Bridge.
Authentication Type	Specifies open-system or shared key.
Encryption	Specifies the enabled state of encryption; either yes or no.
Cipher Advertised	Specifies current state of advertised cipher negotiations, AES and/or WEP, and None (clear).
Authentication/Deauthentication	Number of times a STA attempted authentication and deauthentication.
Association/Deassociation	Number of times a STA attempted associations and deassociations.
MSDU	Maximum Service Data Unit. Specifies the number of packets sent and received by the Bridge.
Data/Management/Control	Packets can either be data, control, or management. Specifies the number of packets sent and received for each.
Multicast	Specifies the number of multicast packets both sent and received.
Errors	Specifies the error count for both transmit and receive.
Receive Errors	Specifies the number of receive errors.
Discarded Frames	Specifies the number of receive discarded frames.
Duplicate Frames	Specifies the number of receive duplicate frames.
CRC Errors	Specifies the number of receive CRC errors.
PHY Errors	Specifies the number of receive PHY errors.
DMA Errors	Specifies the number of receive DMA errors.
Transmit Errors	Specifies the number of transmit errors.
Discarded Frames	Specifies the number of transmit discarded frames.
Excessive Retries	Specifies the number of transmit excessive retries.
DMA Errors	Specifies the number of transmit DMA errors.

The Bridge Stats window automatically updates every five seconds.

### 3-14 Station Statistics

To view statistics on any STA, click on the MAC address hyperlink for the desired STA. The BSS Stats window for the selected STA will appear. See Figure for an example BSS Stats window for a station.

The BSS Stats window for stations provides the station configuration and statistics for the selected station. (See figure)



Table summarizes the information fields on the BSS Stats window for a STA.

Table. BSS Stats Fields for STA Descriptions

BSS Stats Window for STA Field	Description
AID	The ID of the STA.
State	The current state of the STA
Power Save	Specifies the enabled state of the power save option; either yes or no.
Encryption	Specifies current state of encryption; AES and/or WEP, and None (clear).
Advertised Cipher	Specifies the supported cipher types.
Unicast Cipher	Specifies the current unicast cipher type used.
Multicast Cipher	Specifies the current multicast cipher type used.
Authentication/Deauthentication	Number of times a STA attempted authentication and deauthentication.
Association/Deassociation	Number of times a STA attempted associations and deassociations.
MSDU	Maximum Service Data Unit. Specifies the number of packets sent and received by the STA.
Data/Management/Control	Packets can either be data, control, or management. Specifies the number of packets sent and received for each.
Multicast	Specifies the number of multicast frames.
Errors	Specifies the error count for both transmit and receive sides.
Signal Strength	Specifies the strength of the transmit and receive signals in dBm.
Data Rate (Mbps)	Specifies the transmit and receive data rate in Mbps.
Receive Errors	Specifies the number of receive errors.
Discarded Frames	Specifies the number of receive discarded frames.
Duplicate Frames	Specifies the number of receive duplicate frames.
CRC Errors	Specifies the number of receive CRC errors.
PHY Errors	Specifies the number of receive PHY errors.
DMA Errors	Specifies the number of receive DMA errors.
Transmit Errors	Specifies the number of transmit errors.
Discarded Frames	Specifies the number of transmit discarded frames.
Excessive Retries	Specifies the number of transmit excessive retries.
DMA Errors	Specifies the number of transmit DMA errors.

## 3-15 Bridge setup window

---

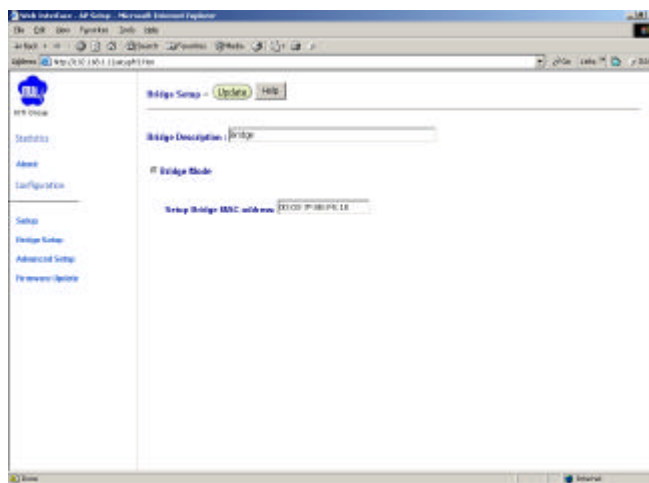

In this window, to input what the equipment it is. All the fields are described as following table:

Bridge window field	Description
Bridge Description	Enter your description for your bridge system
Operation Mode	Select which mode the equipment used: <ul style="list-style-type: none"><li>• AP Mode</li><li>• Bridge Mode (only this item active now)</li><li>• AP/Bridge Mode</li></ul>
Setup Bridge MAC address	Enter the MAC address for bridge installed on the other side.



## Appendix A Acronyms & Abbreviations

---

AC	Alternating Current	LAN	Local Area Network
ACL	Access Control List	MAC	Media Access Control
AES	Advanced Encryption Standard	MSDU	Maximum Service Data Unit
AID	Access Identifier	ODU	Outdoor Unit
AP	Access Point	PC	Personal Computer
BBS	Basic Service Set	PHY	Physical Layer
CLI	Command Line Interface	POE	Power Over Ethernet
CRC	Cyclic Redundancy Code	RADIUS	Remote Authentication Dial-In User Server/Service
DC	Direct Current	RSSI	Received Signal Strength Indication/Indicator
DMA	Direct Memory Access	SNMP	Simple Network Management Protocol
DNS	Domain Name Server/Service	SSID	Service Set Identifier
DOS	Disk Operating System	STA	station
ESD	Electrostatic Discharge	TBD	To Be Defined
EULA	End User License Agreement	TCP/IP	Transmission Control Protocol/Internet Protocol
FCC	Federal Communications Commission	TV	Television
FTP	File Transfer Protocol	VDC	Volts Direct Current
GIF	Graphic Interchange Format	WEP	Wired Equivalent Privacy
HPC	Host Personal Computer	VLAN	Virtual Local Area Network
ID	Identification/Identity/Identifier		
IEEE	Institute of Electrical & Electronics Engineers		
JPG	Joint Photographic Experts Group		