

Operating Manual

MHX-2400

2.4 GHz Spread Spectrum OEM Transceiver

Revision 1.20, January 31, 2001



Microhard Systems Inc.

#110, 1144 - 29th Ave. N.E.

Calgary, Alberta T2E 7P1

Phone: (403) 248-0028

Fax: (403) 248-2762

www.microhardcorp.com

MHX-2400

2.4 GHz

Spread-Spectrum Embedded Modem

WARNING

In order to comply with the FCC/IC adopted RF exposure requirements, this transmitter system will be installed by the manufacturer's reseller professional. Installation of all antennas must be performed in a manner that will provide at least 20 cm clearance from the front radiating aperture, to any user or member of the public.

This manual contains information of proprietary interest to Microhard Systems Inc. It has been supplied in confidence to purchasers and users of the MHX-2400, and by accepting this material the recipient agrees that the contents will not be copied or reproduced, in whole or in part, without prior written consent of Microhard Systems Inc.

Microhard Systems Inc. has made every effort to assure that this document is accurate and complete. However, the company reserves the right to make changes or enhancements to the manual and/or the product described herein at any time and without notice. Furthermore, Microhard Systems Inc. assumes no liability resulting from any omissions in this document, or out of the application or use of the device described herein.

Microhard Systems' products are appropriate for home, office, or industrial use, but are not authorized for utilization in applications where failure could result in damage to property or human injury or loss of life.

The electronic equipment described in this manual generates, uses, and radiates radio frequency energy. Operation of this equipment in a residential area may cause radio interference, in which case the user, at his own expense, will be required to take whatever measures necessary to correct the interference.

FCC Declaration of Conformity

This device complies with Part 15 of the FCC Rules. Operation is subject to the following two conditions: (1) this device may not cause harmful interference, and (2) this device must accept any interference received including interference that may caused undesired operation.

Microhard Systems Inc.'s products are warranted against all failures which occur as a result of defective material or workmanship within 12 months of purchase by the user. This warranty does not extend to products that, in the opinion of Microhard Systems Inc., have been subject to misuse, accidents, lightning strikes, improper installation or application, nor shall it extend to units which have, in Microhard Systems Inc.'s opinion, been opened, tampered with or repaired by an unauthorized facility.



Microhard Systems Inc.

Leaders in Wireless Telecom

#110, 1144 - 29th Ave. N.E.

Calgary, Alberta T2E 7P1

Phone: (403) 248-0028

Fax: (403) 248-2762

www.microhardcorp.com

© 2001 by Microhard Systems Inc., All Rights Reserved.

HyperTerminal is copyrighted by Hilgraeve Inc, and developed for Microsoft.

Microsoft and Windows are registered trademarks of Microsoft Corporation.

pcANYWHERE and Symantec are registered trademarks of Symantec Corp.

All other products mentioned in this document are trademarks or registered trademarks of their respective holders.

Manual Revision 1.20, January 31, 2001.

Contents

1.	Introduction	
1.0	Product Overview	1
1.1	Features	1
1.2	About this Manual	2
2.	Electrical/Physical	
2.0	Functional Block Diagram	3
2.1	Pinout	4
2.2	LED Operation	6
2.3	DC Characteristics	8
2.4	AC Characteristics	9
3.	Modes of Operation	11
3.1	Data Mode	11
3.2	Command Mode	12
3.2.1	AT Command Interface	13
3.3	Switching Between Command and Data Modes	13
4.	Configuration	
4.1	Quick Start Approach	15
4.2	AT Commands	16
	A - Answer	17
	E - Command Echo	17
	I - Identification	17
	O - Online Mode	17
	Q - Quiet Mode	17
	V - Result Codes Display	17
	W - Connection Result	18
	Z - Reset Modem and load stored configuration	18
	&C - DCD (Data Carrier Detect)	18
	&D - DTR (Data Terminal Ready)	18
	&F - Load Factory default configuration	18
	&K - Handshaking	18
	&S - DSR (Data Set Ready)	19
	&V - View Configuration	19
	&E - Framing Error Check	19
	&W - Write Configuration to memory	19
	Sxxx? - Read S register value	19
	Sxxx=yyy - Set S register value	19
	Command Result Codes	20
4.3	S Registers	21
	S Register 2 - Escape Code	21
	S Register 3 - CR Control Code	21
	S Register 4 - Linefeed Control Code	21
	S Register 5 - Backspace Control Code	21
	S Register 101 - Operating Mode	22
	S Register 102 - Serial Baud Rate	24
	S Register 103 - Wireless Link Rate	24
	S Register 104 - Network Address	25
	S Register 105 - Unit Address	25
	S Register 106 - Primary Hopping Pattern	25
	S Register 206 - Secondary Hopping Pattern	25
	S Register 107 - Encryption Key	27
	S Register 108 - Output Power Level	27
	S Register 109 - Hopping Interval	28
	S Register 110 - Data Format	29
	S Register 111 - Packet Minimum Size	29
	S Register 112 - Packet Maximum Size	29
	S Register 114 - Packet Size Control	29
	S Register 116 - Packet Character Timeout	29
	S Register 113 - Packet Retransmissions	30
	S Register 213 - Packet Retry Limit	31
	S Register 115 - Packet Repeat Interval	31
	S Register 117 - Modbus Mode	32
	S Register 118 - Roaming	33
	S Register 119 - Quick Enter to Command	33

	S Register 120 - RTS/DCD Framing.....	33
	S Register 121 - DCD Timeout.....	33
	S Register 122 - Remote Control.....	34
	S Register 123 - RSSI Reading.....	34
4.4	Diagnostics, Statistics and Remote Control.....	35
4.4.1	Spectrum Analyzer Feature.....	35
4.4.2	Statistics.....	35
4.4.3	Remote Control and Diagnostics.....	36
5.	Installation.....	39
5.1	Estimating the Gain Margin.....	39
5.2	Antennas and Cabling.....	41
5.2.1	Internal Cabling.....	41
5.2.2	Installing External Cables, Antennas and Lightning Arrestors.....	42
A.	Modem Command Summary.....	45
B.	Serial Interface.....	47
C.	Sample Schematic Diagram.....	49
D.	Factory Default Settings.....	51
E.	Performance Tables.....	53
F.	Hopping Tables.....	55
G.	Technical Specifications.....	57
H.	Glossary.....	61
I.	FCC RF Exposure.....	63

1. Introduction

1.0 Product Overview

The MHX-2400 is a high-performance embedded wireless data transceiver. Operating in the 2.4000-2.4835 GHz ISM band, this frequency-hopping spread-spectrum module is capable of providing reliable wireless data transfer between almost any type of equipment which uses an asynchronous serial interface. The small-size and superior RF performance of this module make it ideal for many applications. Typical uses for this module include:

- SCADA
- Traffic Control
- Remote Monitoring
- Fleet Management;
- Telemetry;
- Remote Camera/Robot Control;
- Security Systems; and,
- Display Signs.

While a pair of MHX-2400 modules can link two terminal devices (“point-to-point” operation), multiple modules can be used together to create a network of various topologies, including “point-to-multipoint” and “repeater” operation. Multiple independent networks can operate concurrently, so it is possible for unrelated communications to take place in the same or a nearby area without sacrificing privacy or reliability.

1.1 Features

Key features of the MHX-2400 include:

- transmission within a public, license-exempt band of the radio spectrum¹ – this means that it can be used without access fees (such as those incurred by cellular airtime);
- a serial I/O data port with handshaking and hardware flow control, allowing the MHX-2400 to interface directly to any equipment with an asynchronous serial interface.

¹

- 49 sets of user-selectable pseudo-random hopping patterns, intelligently designed to offer the possibility of separately operating multiple networks while providing security, reliability and high tolerance to interference;
- encryption key with 65536 user-selectable values to maximize security and privacy of communications;
- built-in CRC-16 error detection and auto re-transmit to provide 100% accuracy and reliability of data;
- ease of installation and use – the MHX-2400 module uses a subset of standard AT style commands, very similar to those used by traditional telephone line modems.

While the typical application for the MHX-2400 is to provide a short- to mid-range wireless communications link between DTEs, it can be adapted to almost any situation where an asynchronous serial interface is used and data intercommunication is required.

1.2 About this Manual

This manual has been provided as a guide and reference for installing and using MHX-2400 wireless modem modules. The manual contains instructions, suggestions, and information which will help you set up and achieve optimal performance from your equipment using the MHX-2400 module.

It is assumed that users of the MHX-2400 module have either system integration or system design experience. Chapter 2 details the requirements and connections of the MHX-2400 module. Chapter 3 describes the AT command register setup and configuration. The Appendices, including the Glossary of Terms, are provided as informational references which you may find useful throughout the use of this manual as well as during the operation of the wireless modem.

Throughout the manual, you will encounter not only illustrations that further elaborate on the accompanying text, but also several symbols which you should be attentive to:



Caution or Warning: Usually advises against some action which could result in undesired or detrimental consequences.



Point to Remember: Highlights a key feature, point, or step which is worth noting. Keeping these in mind will make using the MHX-2400 more useful or easier to use.



Tip: An idea or suggestion is provided to improve efficiency or to make something more useful.

With that in mind, enjoy extending the boundaries of your communications with the MHX-2400 module.

2. Electrical/Physical

2.0 Functional Block Diagram

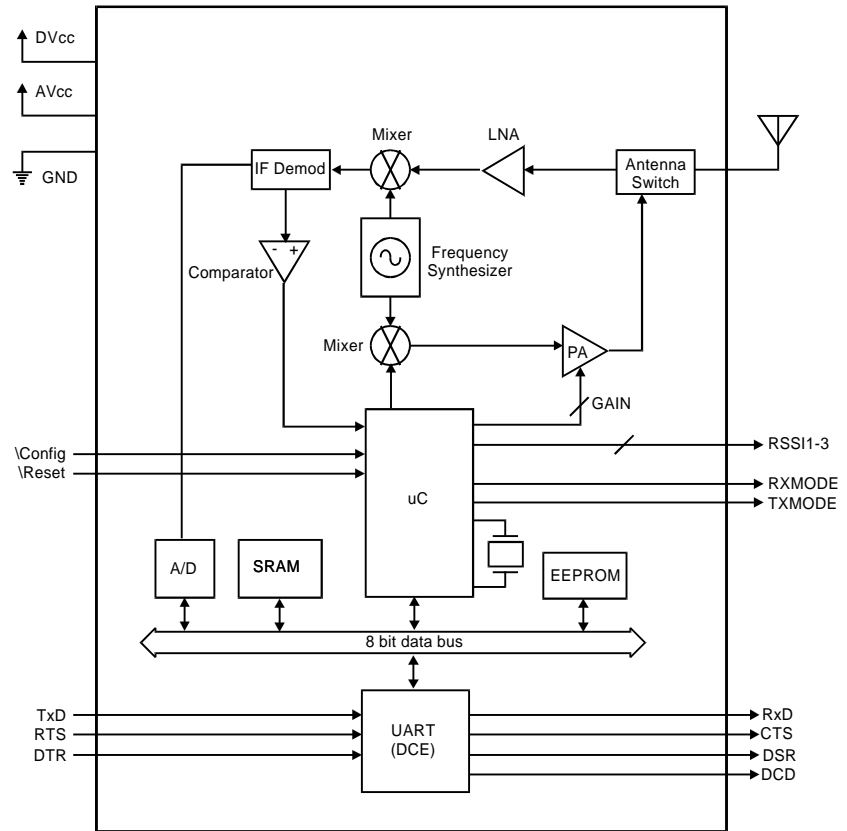

2.1 Pinout

Figure 1 provides a top-view pinout drawing of the MHX-2400 module. The corner pins (1,20,21,40) are labeled directly on the module.

AVcc	<input type="checkbox"/> 1	MHX-2400	40	<input type="checkbox"/> NC
AVcc	<input type="checkbox"/> 2		39	<input type="checkbox"/> NC
DVcc	<input type="checkbox"/> 3		38	<input type="checkbox"/> NC
DVcc	<input type="checkbox"/> 4		37	<input type="checkbox"/> NC
DVcc	<input type="checkbox"/> 5		36	<input type="checkbox"/> NC
DVcc	<input type="checkbox"/> 6		35	<input type="checkbox"/> NC
DVcc	<input type="checkbox"/> 7		34	<input type="checkbox"/> NC
NC	<input type="checkbox"/> 8		33	<input type="checkbox"/> RxMODE
\Config	<input type="checkbox"/> 9		32	<input type="checkbox"/> TxMODE
\Reset	<input type="checkbox"/> 10		31	<input type="checkbox"/> RSSI3
GND	<input type="checkbox"/> 11		30	<input type="checkbox"/> RSSI2
GND	<input type="checkbox"/> 12		29	<input type="checkbox"/> RSSI1
GND	<input type="checkbox"/> 13		28	<input type="checkbox"/> CTS
GND	<input type="checkbox"/> 14		27	<input type="checkbox"/> RTS
GND	<input type="checkbox"/> 15		26	<input type="checkbox"/> DSR
GND	<input type="checkbox"/> 16		25	<input type="checkbox"/> NC
GND	<input type="checkbox"/> 17		24	<input type="checkbox"/> DTR
NC	<input type="checkbox"/> 18		23	<input type="checkbox"/> TxD
NC	<input type="checkbox"/> 19		22	<input type="checkbox"/> RxD
NC	<input type="checkbox"/> 20		21	<input type="checkbox"/> DCD

Figure 1 - Pinout (Top View)

Pin Name	No.	Description	I/O
AVcc	1,2	Positive Supply for Radio Circuitry. See Section 2.3 for DC Characteristics	I
\Config	9	Leave unconnected. For factory use only. Do not ground	
CTS	28	RS-232 Clear to Send. Active low (TTL level) output. See Appendix B for a complete description of all RS-232 signals.	O
DCD	21	RS-232 Data Carrier Detect. Active low (TTL level) output.	O
DSR	26	RS-232 Data Set Ready. Active low (TTL level) output.	O
DTR	24	RS-232 Data Terminal Ready. Active low (TTL level) input.	I
DVcc	3-7	Positive Supply for Logic circuitry and I/O pins. See Section 2.3 for DC Characteristics	I

GND	11-17	Ground reference for logic, radio and I/O pins.	
\Reset	10	Active low reset input to the module. See Section 2.4 for timing information.	I
RSSI1	29	Receive Signal Strength Indicator 1. This output is the first of the three RSSI indicators to become active high as the signal strength increases. See Section 2.2 for details	O
RSSI2	30	Receive Signal Strength Indicator 2. This output is the second RSSI indicator to become active high as the signal strength increases. See Section 2.2 for details.	O
RSSI3	31	Receive Signal Strength Indicator 3. This output is the last RSSI indicator to become active high as the signal strength increases. See Section 2.2 for details.	O
RTS	27	RS-232 Request to Send. Active low (TTL level) input.	I
RxD	22	RS-232 Receive Data. TTL level output.	O
RX/SYNC	33	Active high output indicates receive and synchronization status. See Section 2.2.	O
TxD	23	RS-232 Transmit Data. TTL level input.	I
TXMODE	32	Active high output indicates module is transmitting data over the RF channel. See Section 2.2.	O

2.2 LED OPERATION

LED functionality is dependent on the mode of operation. Lines RX/SYNC, TXMODE, and RSSI1,2 and 3 are designed to drive LED's (active high).

MODE	LED		
	RX/Sync	TXMode	RSSI1,2,3
Power Up (S0=1, S119=1)	off	off	blink 500ms on/500ms off
Power Up (S0=1, S119=0)	off	off	off
Power Up (S0=0)	off	off	off
Command Mode	off	off	off
Data Mode - Master	on while receiving valid data packets from slaves and repeaters in the network	on for the first portion of each hop interval.	RSSI mode based on all received packets See Table 3
Data Mode - Repeater During Sync. Acquisition	off	off	alternating 300ms on
Data Mode - Repeater When Synchronized	on for first portion of hop interval	on for second portion of hop interval	RSSI mode based on packets received from Slaves* See Table 3
Data Mode - Slave During Sync. Acquisition	off	off	alternating 300ms on
Data Mode - Slave When Synchronized	on	on when transmitting a packet.	RSSI mode based on packets received from the Repeater or Master with which it communicates See Table 3

*If Slaves have been silent for 2 seconds, repeater will base its RSSI on packets received from the Master.

Signal strength, which is also reported in Register S123, is calculated based on the last four valid received packets with correct CRC, and represented by RSSI1, 2 and 3.

For slaves, packets are received on every single hop either from a repeater, or the master.

When calculating RSSI, the master takes into consideration all packets received from slaves and repeaters. Repeaters and slaves only transmit back to the master when they have information to send. Therefore, if no data is coming back to the master then RSSI will never get updated at the master, and the LED's will be off.

Table 3 - RSSI mode operation

Signal Strength (dBm)	RSSI1	RSSI2	RSSI3
-108	50% duty cycle	off	off
-101	on solid	off	off
-93	on solid	50% duty cycle	off
-86	on solid	on solid	off
-79	on solid	on solid	50% duty cycle
-71	on solid	on solid	on solid

2.3 DC Characteristics

Sym	Characteristic	Min	Typ	Max	Units
AV _{CC}	Radio Supply Voltage	4.9	5.0	5.5	V
DV _{CC}	Logic Supply Voltage	4.75	5.0	5.5	V
V _{POT}	Power On Reset Threshold Voltage	1.8	2	2.2	V
V _{RST}	Reset Pin Threshold Voltage		$\frac{DV_{CC}}{2}$		V
AI _{CCR}	Radio Supply Current in Receive Mode	96	107	117	mA
AI _{CCT0}	Radio Supply Current at 1mW Transmit	68	108	119	mA
AI _{CCT1}	Radio Supply Current at 10mW Transmit	111	123	135	mA
AI _{CCT2}	Radio Supply Current at 100mW Transmit	157	174	191	mA
AI _{CCT3}	Radio Supply Current at 1W Transmit	398	442	486	mA
DI _{CC}	Logic Supply Current	95	105	115	mA
V _{IL}	Input Low Voltage (Pins 23,24,27)	-0.5		.3DV _{CC}	V
V _{IH}	Input High Voltage (Pins 23,24,27)	0.6V _{CC}		V _{CC} +0.5	V
V _{OL}	Output Low Voltage (Pins 21,22,26,28-33)			0.6	V
V _{OH}	Output High Voltage (Pins 21,22,26,28-33)	4.2			V
IS _{RCE}	Sourcing Current (Pins 21,22,26,28-33)			10	mA



IMPORTANT:

For best performance, it is strongly recommended to use a separate, linearly regulated supply for V_{CC} Radio. Do not directly feed a switching power supply into V_{CC} Radio.



For OEM design simplicity, connect both the radio and logic V_{CC} connections together.



Caution: Using any other power supply which does not provide the proper voltage or current could damage the MHX-2400 module.

2.4 AC Characteristics

Sym	Characteristic	Min	Typ	Max	Units
T _{TOUT}	Reset Delay Time-Out Period		500		ms
T _{R2D}	Internal Reset to Data Mode*	0		5	s
T _{R2C}	Internal Reset to Command Mode		0		ms

*Unit will enter into Command Mode upon power up if register S0=0. Unit will enter into Data Mode upon power-up if register S0=1. When powering up into Data Mode, an additional delay of 5 seconds is added if Register S119=1. See page 20 for details.

Figure 2 provides timing information for both power-up reset and the \backslash Reset line operation. A fixed internal reset delay timer of roughly 500ms is triggered as the V_{POT} or V_{RST} threshold is reached.

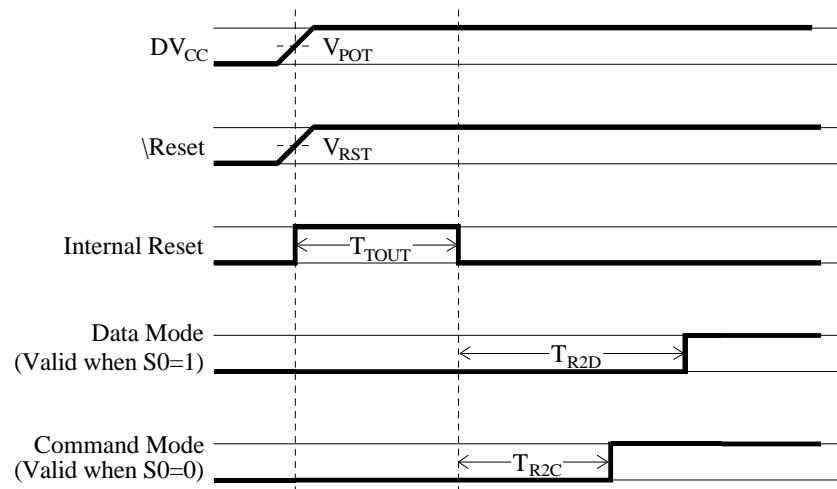

Figure 2. Reset Timing

3. Modes of Operation

The MHX-2400 modem can be easily configured to meet a wide range of needs and applications. The module is designed such that all communication is through one serial port (Pins 21 to 28 on the module). This port has two functions:

1. It provides the asynchronous interface with the host equipment for data that is sent/received on the RF channel. When operating in this fashion, the module is said to be in **data mode**.
2. It is also used for configuring and programming the module. When operating in this fashion, the module is said to be in **command mode**.

In addition to **data mode** and **command mode**, there is a third mode of operation called **diagnostics mode**. The module will always be in one of these three modes.

3.1 Data Mode

Data mode is the normal operating mode of the MHX-2400. When in data mode, the MHX-2400 is communicating with other MHX-2400 modules, and facilitating wireless asynchronous serial communication amongst two or more terminal devices. There are three basic elements to any MHX-2400 communications network:

- One module configured as the **Master**
- Zero or more modules configured as **Repeaters**
- One or more modules configured as **Slaves**

The function of the Master is to provide synchronization for the entire network, and to control the flow of data. There is always one Master per network. The Master is the ultimate destination for all data collected at the various Repeater's and Slave's serial ports. With the network set up for Point-to-Multipoint communication, all data received at the Master's serial port is transmitted to every Repeater and Slave in the network. The MHX-2400 is a frequency hopping transceiver, meaning that it "hops" to a new frequency after a predetermined time interval. This time interval is a fixed time set by the user, and can range from 14ms to 180ms. The MHX-2400 hops according to a pseudorandom pattern of 50 different channels.

When configured as a Slave, the MHX-2400 searches for synchronization with a Master. Network topologies consisting of a single *Master* and virtually any combination of *Slaves* and *Repeaters* may be deployed. The functionality of any particular MHX-2400 can be configured as follows:

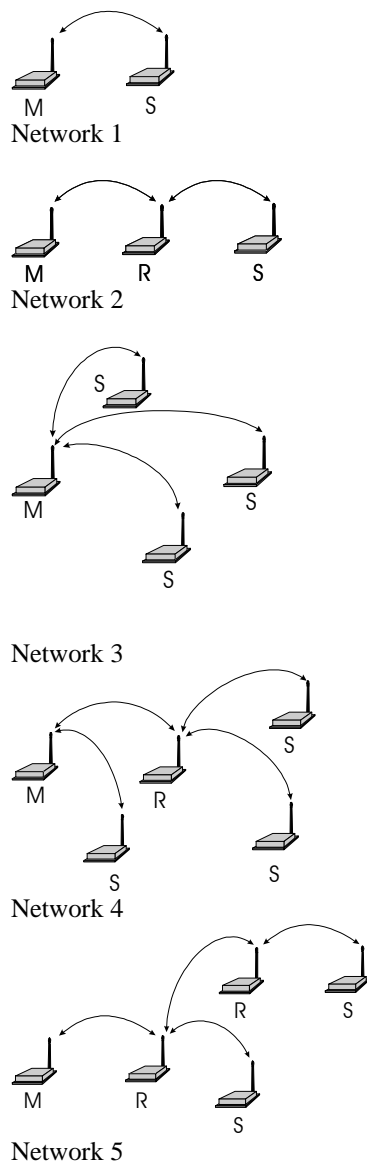

Figure 2 - Sample Network Topologies. Virtually any Combination of Slaves and Repeaters May be Used.

- **Master Point-to-Point:** The modem is configured to communicate with a single *Slave*, either directly, or through one or more *Repeaters*.
- **Master Point-to-Multipoint:** The modem is configured to communicate with one or more *Slaves* and/or *Repeaters*.
- **Slave:** The modem is configured to communicate with one *Master* either directly or through one or more *Repeaters*.
- **Repeater:** The modem is configured to pass information from either a *Master* or another *Repeater* onto subsequent *Repeaters* and/or *Slaves* and vice versa. The *Repeater* also acts as a *Slave* in the sense that, like a *Slave*, it passes information to/from its serial port.

Examples of different network topologies are shown in Figure 4. Network 1 shows Point-to-Point communication between a Master and Slave. Network 2 makes use of a Repeater to communicate with the Slave. Network 3 illustrates a simple Point-to-Multipoint network with no Repeaters. Networks 4 and 5 gives examples of Point-to-Multipoint networks consisting of both Repeaters and Slaves. There is effectively no restriction to the number of Repeaters and Slaves that can be added to a network. As seen in Network 4, a Master can communicate directly with both Slaves and Repeaters.

3.2 Command Mode

The MHX-2400 firmware has been designed to allow the user to customize the operation of the modem through an AT Command Interface. This interface is ideal for direct interface with another microcontroller or for higher level Windows-based software applications, but also contains user-friendly built-in register descriptions. These descriptions make it easy for the user to configure the unit by manually inputting AT Commands and modifying S-Register parameters, using any standard terminal program. The MHX-series development board is a useful tool for familiarizing yourself with the various operating parameters and user interface. Reference schematics for the development board can be found in Appendix G. To access the MHX-2400's command mode using the development board:

1. Insert the module into the socket with the antenna connector towards the edge of the board.
2. Attach the supplied antenna.
3. Connect a straight through serial cable between the DB9 connector and the serial port on your PC
4. Run any terminal application program such as Hyperterminal
5. Set the serial port to 9600 baud, 8N1
6. Apply power to the development board
7. While the three RSSI LED's are blinking, type 'MHX' (you have about 5 seconds to do this). The modem should respond with 'OK'.
8. Type 'AT&V <ENTER>'

3.2.1 AT Command Interface

At this point you should see a menu similar to the following appear:

```
BAUD = 9600
E1 Q0 V1 W0
DCD &C1   DTR &D0   Framing &E0   Handshaking &K3   DSR &S1
S0=1 S2=43 S3=13 S4=10 S5=8
Operating Mode           S101=1           Serial Baud Rate       S102=7
Wireless Link Rate       S103=2           Network Address        S104=1
Unit Address             S105=1           Hop Pattern            S106=0
Encryption Key           S107=1           Output Power           S108=2
Hop Interval             S109=4           Data Format             S110=1
Packet Min Size          S111=1           Packet Max Size        S112=43
Packet Retransmissions   S113=1           Quick enter to command S119=1
Packet Repeat Interval   S115=1           Character Timeout, ms  S116=8
RTS/DCD Framing, ms     S120=0           DCD Timeout, ms       S121=0
Secondary Hop Pattern    S206=2           Packet Retry Limit     S213=2
Average RSSI value       S123= -0 dBm    Modbus Mode            S117=0
Roaming                  S118=0           Packet Size Control    S114=0
Remote Control           S122=0
OK
```

The MHX-2400 is controlled through an AT Command line interface, using a command set which is very similar to a traditional Hayes telephone modem command set.

All line entries must be preceded by the characters 'AT'. The characters 'AT' are known as the attention characters and must be typed at the beginning of each command line. For example, to change the operating mode, type:

```
ATS101=2 <ENTER>
```

The modem should respond with 'OK.' The above command will set the operating mode to Master Point-to-Point.

Register settings are not immediately stored to non-volatile memory, therefore if the modem is powered down at this point, the Operating Mode would revert to its previous value. To store any recently updated command registers, the following "write" command must be entered.

```
AT&W <ENTER>
```

3.3 Switching Between Command and Data Modes

Your modem must be in **command mode** for it to execute a command. If you send characters when the modem is in **data mode**, the modem transmits the characters over the air.

Depending on its settings, the modem will either power up in command mode or data mode. Normally, when first received from the factory, the unit will power up into data mode. During the first five seconds after power-up, the user is given the opportunity to avoid entering into data mode but instead enter into command mode by typing 'MHX'.

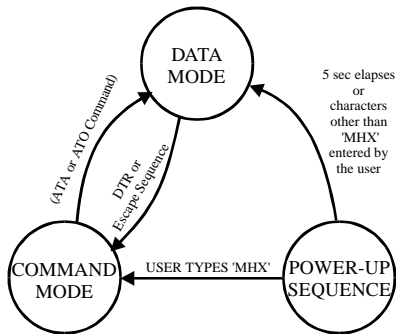

Figure 4A. S0=1, S119=1 (factory default)

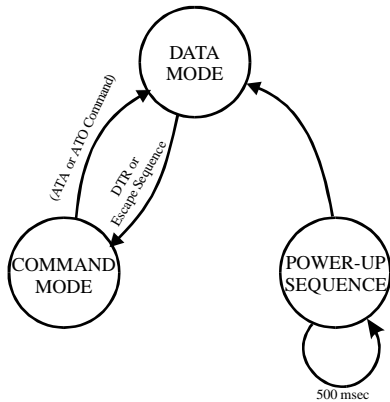

Figure 4B. S0=1, S119=0

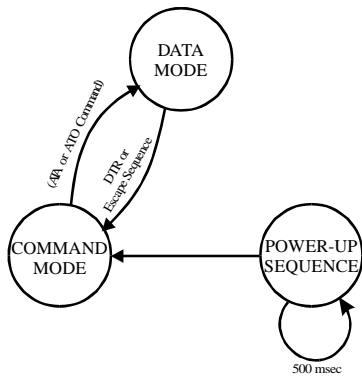

Figure 4C. S0=0



The escape sequence will not be accepted unless both the MHX-2400 and the terminal are set to the same baud rate

The terminal must be set for 9600 baud 8N1 in order for the modem to accept these characters. If 'MHX' is typed incorrectly, the modem will immediately enter into data mode. If the five seconds elapses without any response from the user, the modem will go into data mode.

In command mode, the module "autobauds," meaning that it will adapt to the baud rate of the DTE equipment to which it is connected. Therefore, when in command mode, you may change the baud rate of your equipment, and the MHX-2400 will automatically adjust to this baud rate once an AT string is issued. The new baud rate is stored in register S102. Several baud rates ranging from 2400 to 115200 may be selected.

You can place the modem into Data Mode from Command Mode either by:

- Issuing the answer command (ATA <ENTER>); or,
- Issuing the online command (ATO <ENTER>).

The modem will now attempt to communicate with other MHX-2400 modules. While in Data Mode, the modem will communicate through the serial port at the same baud rate as was last used in Command Mode².

To return to Command Mode, you can either:

- Send the escape sequence. (The escape sequence consists of 1 second of inactivity, followed by the characters '+++' followed by another second of inactivity.); or,
- Toggle the DTR line (depending on the &D parameter see pg 11).

The escape sequence must be issued at the baud rate that the modem has been set to. If the modem is set to 19200 baud, and the escape sequence is issued at 9600 baud, for example, the modem will not recognize it, and will not go into Command Mode.

Figure 4 provides a state diagram for power-up, command mode, and data mode. Note that there are three different variants of the state diagram which depend on the values of registers S0 and S119. See the appropriate sections for more details about these registers. The factory defaults are S0=1 and S119=1.

² It is possible to enter into Data Mode at a different baud rate from what is currently being used in Command Mode by issuing the command AT S102=x, where x is one of the valid baud rates. Care must be taken when setting the baud rate in this manner. If you issue another AT string after attempting to set the baud rate using AT S102 <ENTER>, the modem will again autobaud and automatically revert to the baud rate of the host equipment. For example, if your equipment is running at 9600 baud and you wish to set up the modem to run at 19200 baud, the following command line entry would be suitable:

AT S102=5&WA <ENTER>

The first part (S102=5) sets the baud rate to 19200. The next characters (&W) write this baud rate to memory. The last character (A) puts the modem into Data Mode. Once in Data Mode, the modem is unable to autobaud, and is fixed at 19200 baud. By combining several commands into one command line entry, and then immediately putting the modem online, the modem is not given a chance to autobaud back to 9600.

4. Configuration

This chapter provides a detailed description of the various operating parameters of the MHX-2400. Section 4.1 provides a quick-start approach which outlines the minimum requirements for establishing communication between two MHX-2400 modules. The settings will not necessarily provide optimal performance for your application, but will verify that the modules are functioning correctly.

Section 4.2 describes the AT Command interface, and the various AT Commands. Section 4.3 covers all S-Register parameters which affect the operation of the modem while in data mode, and Section 4.4 provides a description of all diagnostic features of the modem.

4.1 Quick Start Approach

There are several parameters that must be set in order to establish communication between a pair of MHX-2400 modules.

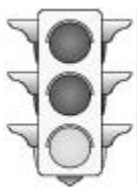

Warning: After testing the units for correct operation using the quick-start approach, be sure to modify some of the security parameters such as Network Address and Encryption Key, to avoid unintentional communication with other users of MHX-2400 products..

The MHX-2400 is equipped with four standard factory default settings. Instead of manually configuring each individual operating parameter, a global command may be used to quickly configure the modem for a particular type of operation. For example, to quickly implement Network 1, Factory default 1 would be applied to the Master, and Factory default 2 would be applied to the Slave. To quickly set up Network 2, apply Factory 1 to the Master, Factory 3 to the Repeater, and Factory 4 to the Slave. *These defaults will get you started and only ensure that a link can be established, but do not necessarily provide the best performance.* Optimization of the communications link is discussed in later sections.

To implement the basic network illustrated in Figure 6, Network 1,

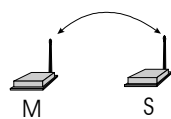

Network 1

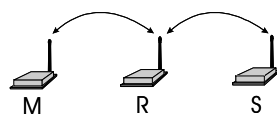

Network 2

Figure 6. Basic Networks

1. Insert the module into the development board socket with the antenna connector towards the edge of the board.
2. Attach the supplied antenna.
3. Connect a straight through serial cable between the DB9 connector and the serial port on your PC
4. Run any terminal application program such as Hyperterminal and set the terminal application's serial port settings to 9600 baud, 8N1
5. Apply power to the development board
6. While the three RSSI LED's are blinking, type 'MHX' (you have about 5 seconds to do this). The modem should respond with 'OK'.
7. Configure the unit to Factory Setting 1 by typing AT&F1 <return>. This puts the unit into Master Point-to-point mode.
8. Store these settings to memory by typing AT&W <return>.
9. Put the modem into Data Mode by typing ATA (or ATO) <return>
10. Perform above steps for the second unit, using Factory Setting 2 instead of Factory Setting 1. This will configure the second unit as a Slave.

The units should now be communicating. Remember, the parameters defined by Factory Settings 1 and 2 will likely not be the most ideal for your application, but will quickly allow you to test the units. A complete summary of the settings defined by all four factory settings can be found in Appendix C. Factory Default Settings.

Settings are not immediately stored in non-volatile memory, therefore, the command &W is issued to store the current configuration into non-volatile memory. Settings are retained even after powering down. All user selectable parameters for the MHX-2400 are described in detail in Sections 4.3 and 4.4:

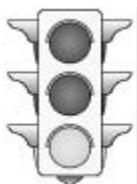

Checking the Link

To check if the units are communicating, observe the LED indicators on the development board which houses the Slave unit. If the link is good, up to three RSSI LED's Slave modem should be active along with the RX/Sync LED, and if the link is absent (due to a fault at one end or another, such as misconfiguration), the LED's will be in either "scanning mode" or inactive. See Section 2.2 for complete LED operation.

Characters typed at the Master terminal should appear at the Slave's terminal, and vice versa. Also, verify that the RX LED blinks as packets of data are received at the Master modem. As data is sent from Slave to Master, the RX indicator should blink on as correct packets of data are received. At this point, the Master's RSSI LED's should become active. It is recommended that if the MHX-2400 will be deployed in the field where large distances separate the units, the modems should be configured and tested in close proximity (e.g., in the same room) first to ensure a good link can be established and settings are correct. This will facilitate troubleshooting, should problems arise.

4.2 AT Commands

Several AT Commands are supported by the MHX-2400. These commands affect the operation of the modem in command mode and the transition between data and command modes. More commands and S-Register settings are discussed in Sections 4.3 and 4.4.

To make the command line more readable, you can insert as many spaces as desired. The command line holds up to 16 characters, not including the AT prefix. If you want to send more than one command line, wait for a response before entering the AT prefix at the start of the next command line.

To re-execute the previous command, enter A/. The modem will execute the previous command line.

When in Command Mode, the modem "autobauds", meaning that it will automatically adjust to the baud rate of the terminal. You may change the terminal baud rate while in Command Mode without losing communication with the modem.

For the AT command protocol, an escape sequence consists of three consecutive escape codes preceded and followed by at least 1 second of inactivity. Typically, the '+' character is used as the escape code.

+++ preceded and followed by 1 second of inactivity



The escape sequence will not be accepted unless both the MHX-2400 and the terminal are set to the same baud rate

Note that the terminal must be configured to the same baud rate as the modem in order for the modem to recognize the escape sequence. The modem is unable to “autobaud” while in Data Mode.

The following is a description of all available commands. ‘*’ denotes standard factory settings. All of the following commands must be preceded by “AT”.

A Answer

The A command puts the modem into data mode, where the modem attempts to communicate with other compatibly configured modems (Type ATA <return>).

E Command Echo

Your modem is preset to return (or echo) commands to the host microprocessor when in Command Mode.

E0 No Command Echo
***E1** Command Echo

I Identification

The I command returns various modem information settings.

I1 Product Code (MHX-910)
I2 Issue ROM Check (OK or ERROR)
I3 Product Identification (Firmware Version)
I4 Firmware Date
I5 Firmware Copyright
I6 Firmware Time
I7 Serial Number

O On-line Mode

The O command puts the modem into data mode. This command is identical to the A command.

Q Quiet Mode

Your modem is preset to send responses when it executes commands, and there after to keep the host informed of its status.

***Q0** Enable modem responses
Q1 Disable modem responses

V Result Codes display

Your modem can either display result codes as words or numbers.

V0 Display Result Codes as numbers
***V1** Display Result Codes as words

W Connection Result

This parameter determines the modem response at the transition from Data Mode to Command Mode

***W0** Reports computer (DTE) baud rate as CONNECT xxxx
W1 Reports wireless rate between modems as CARRIER xxxx.
W2 Reports modem (DCE) baud rate as CONNECT xxxx



Refer to Appendix A (page 19) for a summary of the modem commands

Z Reset and load stored configuration

The Z command resets the modem and loads the stored configuration.

&C DCD (Data Carrier Detect)

The &C command controls the modem's DCD output signal to the host microprocessor. This command determines when the DCD is active.

&C0 DCD is always ON

***&C1** DCD on when modems are synchronized. DCD is always on when unit is configured as Master.

&C2 DCD used for output data framing and Modbus mode. See page 25 for details.

&D DTR (Data Terminal Ready)

The &D command controls what action the modem performs when the DTR input line is toggled. The DTR input is controlled by the host microprocessor.

***&D0** DTR line is ignored

&D1 Not Supported

&D2 DTR disconnects and switches to Command Mode

&D3 DTR disconnects and resets modem. Modem will remain in this state until DTR again goes active.

&F Load Factory Default Configuration

The &F command resets the modem and loads the default factory configuration.

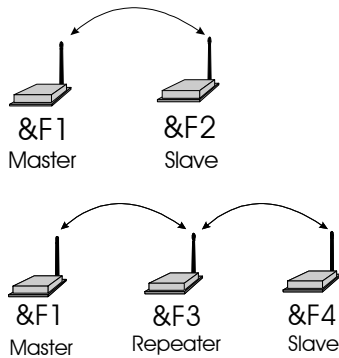

&F1 Master Point-to-Multipoint. Designed to communicate with modems configured as &F2 or &F3.

&F2 Slave. Designed to communicate with another modem configured as &F1.

&F3 Repeater. Designed to communicate with modems configured as &F1 and &F4.

&F4 Slave working with factory default Repeater and factory default Master. Communicates directly with Repeater configured as &F3.

&K Handshaking

The &K command controls the handshaking between the modem and host microprocessor.

&K0 Disable handshaking

&K2 RTS/CTS input data framing. See page 25 for details.

***&K3** Enable hardware handshaking (RTS/CTS)

&S DSR (Data Set Ready)

The **&S** command controls the DSR line for the modem, and determines when it is active

&S0 DSR is always ON

***&S1** DSR is ON in Data Mode, OFF in Command Mode

&S2 DTR/DSR signaling. With **&S2**, Slaves and repeaters output the state of the master's DTR on their local DSR line. Master outputs the state of a slave's DTR on its local DSR line only in point-to-point mode (i.e., DTR is a two-way signal transfer in point-to-point mode, and a one-way signal transfer in point-to-multipoint mode).

&V View Configuration

The **&V** command displays all **S** registers and their current values.

&E Framing Error Check

This command enables or disables Framing Error Check. When enabled, the modem looks for the stop bit. If the stop bit is absent, the byte is thrown out. When enabled, the modem also does a parity check. Note that the data format (number of data bits, parity type, and number of stop bits) is defined by **S** register 110.

***&E0** Disable Framing Error Check

&E1 Enable Framing Error Check

&W Write Configuration to Memory

The **&W** command stores the active configuration into the modem's non-volatile memory.

Sxxx? Read S register value

This command causes the modem to display the current setting of **S** register xxx.

Sxxx=yyy Set S register value (see section 3.3 S-Registers)

This command sets the specified **S** register to a value specified by yyy.



Configuration options are not stored in non-volatile memory until the WRITE command (**&W**) is executed

AT Command Result Codes

The MHX-2400 module can display the results of a command as either text strings or numerical data. The following chart shows resulting text string and corresponding numeric result.

0	OK
3	NO CARRIER
4	ERROR
7	CONNECT 2400
8	CONNECT 3600
9	CONNECT 4800
10	CONNECT 7200
12	CONNECT 9600
13	CONNECT 14400
14	CONNECT 19200
15	CONNECT 28800
17	CONNECT 38400
18	CONNECT 57600
33	CONNECT 115200
62	CARRIER 45000
64	CARRIER 20000



Refer to Appendix A (page 19) for a summary of the S-Registers.



S Registers 2 through 5 cannot be stored to non-volatile memory.

4.3 S Registers

The S Registers described in this section affect the operating characteristics of the modem.

S Register 0 - Auto Answer

If this register is set to zero, the modem will power up in command mode. If this register is set to one, the modem will power up in data mode.

S Register 2 - Escape Code

This register contains the ASCII value of the escape character.

The default value (decimal 43) is equivalent to the ASCII character '+'. Values greater than 127 disable the escape feature and prevent you from returning to the Command Mode. This register cannot be stored to non-volatile memory. If the modem is reset, or powered down, the default value is restored.

Default is '+' (decimal 43).

S Register 3 - CR Control Code

This register contains the ASCII value of the carriage return character.

This is the character that is used to end the command line and is also the character that appears after the modem sends a response. This register cannot be stored to non-volatile memory. If the modem is reset, or powered down, the default value is restored.

Default is 'CR' (decimal 13).

S Register 4 - Linefeed Control Code

Register S4 sets the ASCII value of the linefeed character.

The modem sends the linefeed character after sending a carriage return character when sending text responses. This register cannot be stored to non-volatile memory. If the modem is reset, or powered down, the default value is restored.

Default is 'LF' (decimal 10).

S Register 5 - Backspace Control Code

Register S5 sets the ASCII value of the backspace character.

This character is both the character created by entering BACKSPACE and the character echoed to move the cursor to the left. This register cannot be stored to non-volatile memory. If the modem is reset, or powered down, the default value is restored.

Default is 'BS' (decimal 8).



Only one Master can exist for each network.

S Register 101 - Operating Mode

The Operating Mode (register S101) partly defines the “personality” of the MHX-2400 module. Allowable settings for this register are 1 through 5 as follows:.

- S101=1 Master Point to Multipoint
- S101=2 Master Point to Point
- S101=3 Slave
- S101=4 Repeater
- S101=5 Master - Diagnostics (see Section 4.4)

The default for this register depends on which factory default is selected as shown below:

- Default for Factory Setting &F1 is 1 (Master Point-to-Multipoint)
- Default for Factory Setting &F2 is 3 (Slave)
- Default for Factory Setting &F3 is 4 (Repeater)
- Default for Factory Setting &F4 is 3 (Slave)

1)Master - Point to Multipoint. In any given network, there is always only one Master. All other units should be configured as either Slaves or Repeaters. When defined as a Point-to-Multipoint Master, the modem broadcasts data to all Slaves and Repeaters in the network, and is also the ultimate destination for data transmitted by all Slaves and Repeaters. In addition, the Master defines the following network parameters to be utilized by all other modems in the network (See the appropriate sections for a complete description of these parameters):

- Maximum Packet Size (S112)
- Minimum Packet Size (S111)
- Wireless Link Rate (S103)
- Hop Interval (S109)

2)Master - Point to Point. This mode of operation is identical to Master Point-to-Multipoint, with the exception that the Master only broadcasts to one particular Slave or Repeater. The modem with which communication occurs is defined by the Unit Address (S105). For example, if a Slave has been assigned Unit Address 100, and the Master wishes to communicate with that Slave, the Master must also be assigned a Unit Address of 100. If there are Repeaters in the network, they will pass the packet through to the Slave, and vice versa. Because Repeaters also have Slave functionality (i.e., a Repeater can be connected to a terminal), the Master can choose to communicate solely with a Repeater. This would be accomplished by assigning the same Unit Address to both the Master and the Repeater.

3) Slave. Up to 65534 Slaves may exist in a network, all of which communicate with the common Master (either directly or via Repeater(s)). Slaves cannot directly communicate with other. Slaves only provide acknowledgement for packets of data sent by the Master when the Master is in Point-to-Point mode. In multipoint mode, multiple slaves would conflict with one another if they were all trying to acknowledge the Master at the same time. The Master does, however, send acknowledgements to all messages it receives from Slaves. The Master initiates communications by sending a broadcast message to all Slaves. All Slaves are free to respond in a “Slotted ALOHA” fashion, meaning that each Slave can choose one of several windows in which to transmit. If there happens to be two Slaves attempting to talk at the same time, the Master may not receive the data, and the Slaves therefore would not get an acknowledgement. At this point, the Slaves would attempt to get the information through at random time intervals, thus attempting to avoid any more conflicts. Special parameters which control the Slave’s response characteristics can be modified with S Registers S115 and S213.

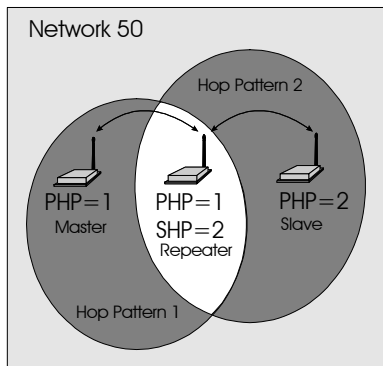

Figure 3 - Repeater Operation

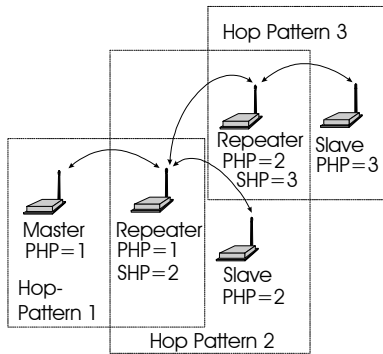

Figure 4 - A Network Utilizing Three Hopping Patterns



If there is no DTE connected to the Repeater, turn off handshaking (&K0) and set the baud rate to 115K.

4) Repeater. A more precise title would be Repeater/Slave, because a Repeater also has much of the same functionality as a Slave. A terminal can be connected at the Repeater location and communicate with the Master terminal. There is no restriction to the number of Repeaters in a network, allowing for communication over virtually limitless distances. The presence of one Repeater in a network automatically degrades system throughput by half. Additional Repeaters, regardless of the quantity, do not diminish system throughput any further. To understand Repeater operation, consider the module as belonging to two hopping patterns at the same time: The Primary Hopping Pattern and the Secondary Hopping Pattern. In Figure 3, the Master belongs to Hopping Pattern 1, and communicates with the Repeater on this hopping pattern. The Slave belongs to Hopping Pattern 2, and communicates with the Repeater on this hopping pattern. The whole system belongs to Network 50 (i.e., all units must be assigned the same Network Address (S104), which in this case was selected to be 50. Note that Slaves and Master only communicate on their respective Primary Hopping Pattern. Repeaters communicate on the Primary Hopping Pattern when communicating with the Master (or with another Repeater between itself and the Master). Repeaters communicate on their Secondary Hopping Pattern when communicating with Slaves (or with another Repeater between itself and the Slaves). Figure 4 shows another example.

If the Repeater is not also being used as a Slave (there is no DTE connected to the serial port), it is recommended that the Repeater’s baud rate be set to 115K, and that handshaking be disabled (&K0). This will help ensure a smooth flow of data through the network.

S Register 102 - Serial Baud Rate

The Serial Baud Rate is the current speed that the modem is using to communicate with the DTE. In command mode, the module “autobauds,” meaning that it will adapt to the baud rate of the DTE equipment to which it is connected. Therefore, when in command mode, you may change the baud rate of your equipment, and the MHX-2400 will automatically adjust to this baud rate once an AT string is issued. The new baud rate is stored in register S102. If you issue a command to change the value of S102, the instant you issue another command, the baud rate will revert back to that of the DTE equipment. Therefore, it is advisable to operate in Command Mode at the desired baud rate for Data Mode.

See page 14 for additional information.

The possible values are:

1	115200
2	57600
3	38400
4	28800
5	19200
6	14400
7	9600
8	7200
9	4800
10	3600
11	2400

It is generally advisable to choose the highest rate that your terminal equipment will handle to maximize performance, unless a limitation on the available bandwidth is desired. If the DTE is a personal computer, the port can usually be used reliably at 115200. Issuing the &Fx command (factory default) does not affect the current setting of S102.



The Master determines the Wireless Link Rate. This setting on all other modems is ignored..

S Register 103 - Wireless Link Rate

The Wireless Link Rate is the speed and optimization method for which modems will communicate over the RF link. It is only necessary to set this parameter on the Master unit. Units configured as Repeaters and Slaves will ignore this setting, and adjust automatically to the rate of the Master.

The allowable settings are:

2	Fast without Forward Error Correction
*4	Fast with Forward Error Correction

Depending on the application requirements, each mode will provide different throughput and performance. Appendix E. Performance Tables give some indication of the performance to be expected in each mode.

In general, Forward Error Correction (FEC) reduces throughput, but in some environments will actually increase throughput. FEC can reduce the number of bad data packets, and hence reduce the need to retransmit.



Select a Network Address and assign it to all units which will be included in the network.

S Register 104 - Network Address

The Network Address defines the membership to which individual units can be a part of. By establishing a network under a common Network Address, the network can be isolated from any other concurrently operating network. As well, the Network Address provides a measure of privacy and security. Only those units which are members of the network will participate in the communications interchange. Valid values for the Network Address range from 0 to 65535, inclusive.

To enhance privacy and reliability of communications where multiple networks may operate concurrently in close proximity, it is suggested that an atypical value be chosen – perhaps something meaningful yet not easily selected by chance or coincidence.

Default is 1.



Use the same Unit Address on both units for point-to-point mode. In multipoint mode, set each Slave and Repeater to a different Unit Address.

S Register 105 - Unit Address

In point-to-point operation, the Unit Address on both the Master and Slave (or Repeater) units must be the same. In a multipoint system, the Unit Address uniquely identifies each Slave and Repeater from one another. Each unit in a multipoint system must have a unique Unit Address ranging from 1 to 65535. Do not use 0 as a Unit Address, and do not use a Unit Address more than once within the same Network. This is required because the Master must be able to acknowledge each unit individually, based on the Unit Address.



Valid Unit Addresses are 1 to 65535.

S Register 106 - Primary Hopping Pattern

S Register 206 - Secondary Hopping Pattern

Since the MHX-2400 is a frequency-hopping modem, the carrier frequency changes periodically according to one of 64 pseudo-random patterns, defined by the Primary and Secondary Hopping Patterns. Valid entries for each are 0 through 63. Patterns 0 through 57 are pre-programmed, with details provided in Appendix F. Patterns 58 through 63 are user-editable patterns. See Appendix F for details.

The concept of Primary and Secondary Hopping Patterns was introduced in the discussion of S Register 101 (Operating Mode).

Using the designations $M[a,]$ $Rx[a,b]$ and $Sx[a]$ where:

- M indicates Master;
- R indicates Repeater;
- S indicates Slave;
- x is the Unit Address;
- a is the primary hopping pattern; and,
- b is the secondary hopping pattern;

the following diagrams illustrate the methodology for deploying simple to complicated networks:

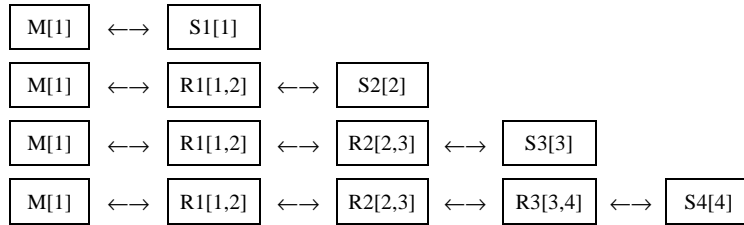
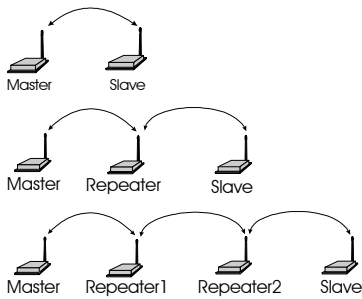

It is reasonable to consider a Repeater as being both a Slave and a Master, alternating between Primary and Secondary Hopping Patterns as the unit changes channel. Consider R1 in the illustration below. When communicating with the Master, R1 is acting like a Slave on Primary Hopping Pattern 1. When communicating with R2 and S4, R1 is acting like a Master on Secondary Hopping Pattern 2. If multiple Repeaters are used, they should have different Secondary Hopping Patterns:

 Slaves and Masters do not use Secondary Hopping Patterns

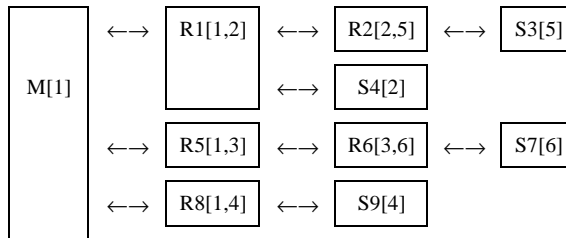

Note that all units have a unique Unit Address.

 Remember to assign a unique Unit Address (1 to 65535) to each unit in the system

Networks of any complexity can be created by linking multiple Repeaters and Slaves:

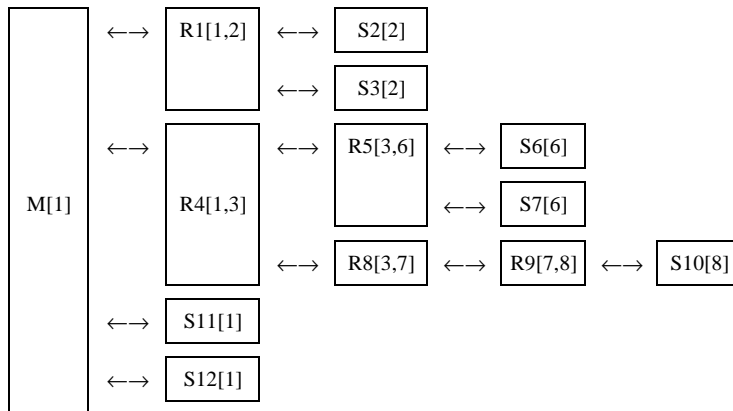

With a limitation of 49 hopping patterns, one might suspect that there is a limitation to the number of repeaters in a system. However, if the units are far enough away from one another, hopping patterns may be reused in different sections of the network, without causing interference.



All units within a network must use the same encryption key.

S Register 107 - Encryption Key

The Encryption Key provides a measure of security and privacy of communications by rendering the transmitted data useless without the correct key on the receiver. Valid Encryption Keys range from 0 to 65535.

Keep in mind that all units within the network must use the same key for communications to succeed.

S Register 108 - Output Power Level

The Output Power Level determines at what power the MHX-2400 transmits. The MHX-2400's sensitive receiver can operate with very low power levels, so it is recommended that the lowest power necessary is used; using excessive power contributes to unnecessary "RF pollution".

The allowable settings are:

0	10 mW	*4	500 mW
1	50 mW	*5	750 mW
2	100 mW	*6	1 W
*3	250 mW		



*The MHX-2400, when sold with antennas with gain higher than 6dBi, shall be factory limited to no more than 100 mW. Only settings 0, 1 and 2 are available.

Ideally, you should test the communications performance between units starting from a low power level and working upward until the RSSI is sufficiently high and a reliable link is established. Although the conditions will vary widely between applications, typical uses for some of the settings are described below:

Power	Use
10 mW	For in-building use, typically provides a link up to 300 feet on the same floor or up/down a level. Outdoors, distances of 10 km can be achieved if high-gain (directional) antennas are placed high above ground level and are in direct line-of-sight.
50 mW	200-500 ft indoors, 8-15 km* outdoors.
100 mW	400-800 ft indoors, 15-25 km* outdoors.
1000 mW (1 W)	Typically provides communications up to a distance of 1000 feet or more in-building on the same floor or up/down a few levels, depending on building construction (wood, concrete, steel, etc.). In ideal line-of-sight conditions, up to 30 km* or more can be achieved. Note that only an antenna with a gain of no more than 6 dBi may be used. Any higher is a violation of FCC rules. See IMPORTANT warning below.

* These outdoor distances assume antennas are mounted at least 100 ft above ground level



FCC Regulations

IMPORTANT:

FCC Regulations allow up to 36 dBi effective radiated power (ERP). Therefore, the sum of the transmitted power (in dBm), the cabling loss and the antenna gain cannot exceed 36 dBi.

1 mW = 0 dBm

10 mW = 10 dBm

100 mW = 20 dBm

1000 mW = 30 dBm

For example, when transmitting 1 Watt (30 dBm), the antenna gain cannot exceed $36 - 30 = 6$ dBi.

Microhard Systems Inc. limits the MHX-2400's transmitted power to 100mW for all units purchased with antennas with gain above 6dBi.



The hopping interval is controlled by the master. The slave and repeater units will use the hopping interval setting from the master.

S Register 109 - Hopping Interval

This option determines the frequency at which the modems change channel. Note that the Master controls this parameter for the entire network. This setting is ignored in units configured as Slaves or Repeaters.

The allowable settings are:

1	8 msec
2	12 msec
3	16 msec
4	20 msec
5	30 msec
6	45 msec
7	80 msec
*8	120 msec



Warning: Communication will fail if the hopping interval is not set according to the guidelines of Appendix E.;

Some of the shorter hop intervals are incompatible in combination with:

- repeaters in the system;
- the value set for link rate (S103); and,
- larger maximum packet sizes (S112).

See Appendix E for optimal Hopping Interval settings in relation to packet size and link rate.

S Register 110 - Data Format

This register determines the format of the data on the serial port. Allowable settings are:

*1	8 bits, No Parity, 1 Stop
2	8 bits, No Parity, 2 Stop
3	8 bits, Even Parity, 1 Stop
4	8 bits, Odd Parity, 1 Stop
5	7 bits, No Parity, 1 Stop
6	7 bits, No Parity, 2 Stop
7	7 bits, Even Parity, 1 Stop
8	7 bits, Odd Parity, 1 Stop
9	7 bits, Even Parity, 2 Stop
10	7 bits, Odd Parity, 2 Stop
11	9 bits, No Parity, 1 Stop

S Register 111 - Packet Minimum Size

S Register 112 - Packet Maximum Size

S Register 114 - Packet Size Control

S Register 116 - Packet Character Timeout

These settings determine the conditions under which the modem will transmit accumulated data over the air.

S Register 111 - Minimum Size

Valid entries for this register are 1 to 255 bytes, which defines the minimum number of bytes to receive from the DTE before encapsulating them in a packet and transmitting over the air.

Note that if register S114=0 at any particular Repeater or Slave, that Repeater or Slave will ignore its own S111 register and abide by the Master's S111 setting. If S114=1 at any particular Repeater or Slave, that Repeater or Slave will use its own local S111 setting. The default for S111 is 1 byte.

S Register 112 - Maximum Size

This setting has a range of 2 to 255, and defines the maximum number of bytes from the DTE which should be encapsulated in a packet. This value should be greater than the minimum packet size, but not smaller than is necessary for reliable communications. If the wireless link is consistently good and solid, a maximum size of 255 will yield the best throughput (depending on the higher level protocols of the connected equipment). However, if the link is poor (*e.g.*, experiencing excessive interference) and data is frequently retransmitted, the maximum packet size should be reduced. This decreases the probability of errors within packets, and reduces the amount of traffic in the event that retransmissions are required.

Note that if register S114=0 at any particular Repeater or Slave, that Repeater or Slave will ignore its own S112 register and abide by the Master's S112 setting. If S114=1 at any particular Repeater or Slave, that Repeater or Slave will use its own local S112 setting. The default for S112 is 255 bytes.



When S114=0, the Minimum and Maximum Packet Size is controlled by the Master, therefore, the Slave and Repeater units will use the Minimum and Maximum Packet Size setting from the Master. When S114=1, Slave and Repeater units will use their local S111 and S112 settings for packet size control

S Register 114 - Packet Size Control

This register, when set to 1, allows for Repeater and Slaves' local S111 and S112 to override those of the Master. This may be useful for controlled asymmetrical data flow. The master always transmits in the first portion of the hop interval, with slaves and repeaters responding back to the master on the second portion of the hop interval. Setting the master's max packet size smaller than that of the slave would ensure that the master uses less of the available time within the hop interval for transmitting data, thereby allocating more time for the slave.

S Register 116 - Packet Character Timeout

This register has valid entries of 0 to 254 milliseconds. The Packet Character Timeout timer looks for gaps in the data being received from the DTE. The timer is only activated after the Minimum Packet Size has been accumulated in the modem. After which, if the timer detects a gap in the data exceeding the Packet Character Timeout value, the modem will transmit the data.

The MHX-2400 will accumulate data in its buffers from the DTE until one of the following requirements is met (whichever occurs first):

- The Maximum Packet Size (in bytes) has been accumulated;
- The Minimum Packet Size has been accumulated AND the Packet Character Timeout interval has elapsed.

The default for the Packet Character Timeout is 9 ms. If set to 0 ms, the unit will buffer exactly the minimum packet size before transmitting.

S Register 113 - Packet Retransmissions

This register applies to both Master Point-to-Multipoint and Repeater operation. It does not apply to Slave or to Master Point-to-Point operation. The Master will retransmit each data packet exactly the number of times defined by the Packet Retransmissions parameter. The Master retransmits once at the beginning of each hopping interval until the limit is reached. This parameter is not necessary in Slave units since all Slaves receive acknowledgement from the Master, and needn't blindly retransmit if it has knowledge that the Master has received the packet. Similarly, this parameter is not used by the Master during Point-to-Point communication since the Master only would be required to retransmit if no acknowledgement were received from the Slave. As discussed previously, the Repeater effectively behaves as both a Master and a Slave. When the Repeater is tuned to its Secondary Hopping Pattern (acting as a Master), the Packet Retransmissions Parameter comes into play. The Repeater will re-send packets of data on to Slaves or other Repeaters exactly the number of times defined by the Packet Retransmissions parameter.

Recipients of the packet will discard any duplicates. The valid settings for this parameter are 0 to 255 retransmissions. The default is 2.

S Register 213 - Packet Retry Limit

Packet Retry Limit is analogous to Packet Retransmissions, but specifically applies to Slaves, Repeaters and Point-to-Point Masters. This parameter is not used by the Master in Point-to-Multipoint networks. Because the Slave has the advantage of receiving acknowledgements from the Master, it is not necessary to blindly retransmit each packet. If the Slave does not get an acknowledgement on the next hop, it will retransmit its packet. This will continue until the Packet Retry Limit is reached or an acknowledgement is received. If the limit is reached, the modem will give up and discard the data. Valid settings are 0 to 255 retries. The default value is 2.

The Repeater makes use of this parameter when it is tuned to its Primary Hopping Pattern and is acting like a Slave. Likewise, the Master in a Point-to-Point network uses this parameter because it is expecting to receive acknowledgement from a Slave. Acknowledgements from Slaves cannot be carried through repeaters back to the Master. Therefore in point-to-point networks that make use of repeaters, care must be taken not to set the Packet Retry Limit too high.

S Register 115 - Packet Repeat Interval

A parameter that is specific to Slaves and Repeaters is the Packet Repeat Interval.

The allowable settings are 1 through 255. The default is 1.

This parameter defines a range of random numbers that the Slave will use as the next slot in which it will attempt to send the packet. For example, if this register is set to 7, the Slave will choose a number between one and seven as the next slot in which to transmit. Suppose the random number generator picks 5, then the Slave will transmit in the fifth time slot. A Slave will transmit a maximum of once per hopping interval, however, depending on the duration of the hopping interval and the maximum packet size, more than one slot per hop is potentially available. The Slave will transmit more frequently when a Repeat Interval with a smaller range is selected. Choose 1 to have the Slave transmit in the first available slot. Choose higher intervals for less frequent transmission, or to avoid collisions between many Slaves in the system.

This register is always disregarded and taken as S115=1 in Point-to-Point mode.

S Register 117 - Modbus Mode

Modbus Mode allows for the MHX-2400 to be fully Modbus compatible. For Modbus operation, the general requirement is to get the packet of data to the receiving serial port with no gaps in the data. The MHX-2400 incorporates a "Modbus Mode" which implements a delay at the receiving modem to ensure that no gaps are introduced. For most applications, the following settings are suitable for Modbus operation:

1. Set Modbus Mode parameter S117 = 1
2. Set the minimum packet size (S111) to 1 byte
3. Set the character timeout S116 (rounded to the nearest ms) to roughly 2.5 byte lengths. For example, at 9600 baud,
$$S116 = 1/9600 \times 10 \times 2.5 \times 1000 = 2.6\text{ms}$$

Rounded up, S116 = 3ms
4. Set parameter S121 = 3 byte lengths. For example, at 19200 baud
$$S121 = 1/19200 \times 10 \times 3 \times 1000 = 1.56\text{ms.}$$

Rounded up, S121 = 2ms
5. Set S120 as follows:
Slave Side
$$S120 = (\text{Hop Interval in ms}) \times (1 + \# \text{ of Master retransmissions}) \times (1 + \# \text{ of Repeaters over 1})$$

eg. Hop Interval S109=4 (20 ms),
Master Retransmissions S113=1
Number of Repeaters in system = 2; then,
$$S120 = 20 \times (1 + 1) \times (1 + 1) = 80 \text{ ms}$$

Master Side
$$S120 = (\text{Hop Interval in ms}) \times (1 + \# \text{ of Repeaters over 1})$$
6. Try to set the hop interval as short as possible while still ensuring adequate throughput. It is recommended to set the Hop Interval and Maximum Packet Size as specified in Appendix E. Performance Tables. For example, for Master to Slave communication with no FEC, If a throughput of 60kbps is required, set the Hop Interval S109=3, and set the Maximum Packet Size S112=110.

The allowable settings for this register are:

*0	Disabled
1	Enabled

S Register 118 - Roaming

This mode is activated on slaves and repeaters by setting register S118=1. In this mode, a slave/repeater looks for synchronization with a Master having the same network address and encryption key, but without regard for the hopping pattern S106. Once the slave/repeater finds such a master, it tunes to that master's hopping pattern. If synchronization is lost, the slave/repeater will again begin searching for a new master. Using this algorithm, a mobile unit can 'roam' and automatically synchronize with a new master once it loses communication with the previous one.

The allowable settings for this register are:

*0 **Disabled**
1 **Enabled**

S Register 119 - Quick Enter to Command

By setting this register to 1, a delay of 5 seconds is introduced at power-up before the modem goes into data mode. If, during these 5 seconds, the user enters 'MHX' the modem will instead go into Command Mode, and reply with 'OK'. The terminal baud rate must be set to 9600 baud. If an incorrect character is entered, the modem will immediately go into Data Mode. The default setting is 1 - Enabled.

S Register 120 - RTS/DCD Framing

S Register 121 - DCD Timeout

The MHX-2400 supports two special types of data framing:

- Input (or RTS/CTS) Data Framing; and,
- Output (or DCD) Data Framing

Input Data Framing is enabled by configuring the Handshaking Parameter as &K2. This type of framing makes use of the S120 parameter as illustrated in Figure 5. Parameter S120 can be set to any value between 0 and 254 ms.

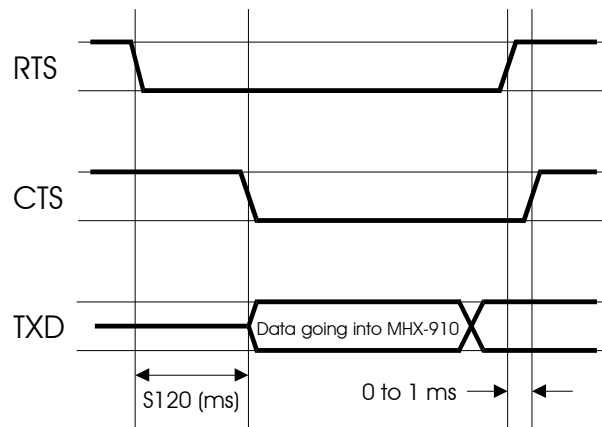

Figure 5 - Input Data Framing

To enable output (DCD) data framing, set the Data Carrier Detect parameter as &C2. This type of framing uses both S120 and S121 registers as shown in Figure 6. Valid ranges for each parameter are 0 to 254 ms

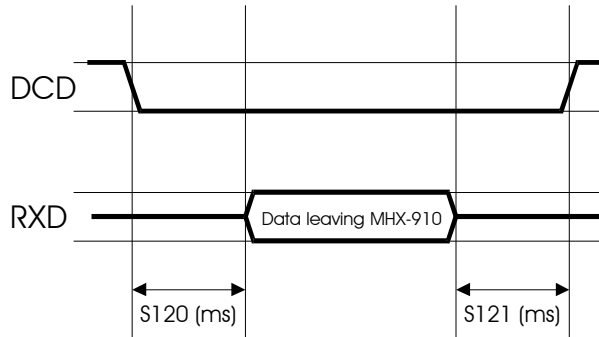

Figure 6 - Output Data Framing

S Register 122 - Remote Control

This register either disables or enables remote control at a repeater or slave unit. When disabled, a slave/repeater's settings may be remotely read by the master, but may not be remotely modified. When enabled, the slave/repeater allows the network master full remote control access. See Section 4.4.3 for details. The default is 0 - disabled.

S Register 123 - RSSI Reading

This register displays the average signal strength in dBm over the previous four hop intervals. The value in this register is also reflected in status lines RSSI1,2 and 3. See Section 2.2 for a description of RSSI, and how it is derived.

4.4 Diagnostics, Statistics and Remote Control

The MHX-2400 provides several commands which are very useful for troubleshooting and analyzing the performance of the radio system.

4.4.1 Spectrum Analyzer Feature (ATG)

Issuing the command ATG <return>, causes the MHX-2400 to perform a sweep of the entire operating spectrum, giving a signal strength read-out in dBm for each channel as shown below:

```
Noise level, '*'- mean value, '.'- max value
ch 1  -138dBm  *
ch 2  -139dBm  *
ch 3  -139dBm  *
ch 4  -139dBm  *
ch 5  -139dBm  *
ch 6  -139dBm  *
ch 7  -130dBm  *
ch 8  -116dBm  *
ch 9  -135dBm  *
...
ch 127 -135dBm *
Paging -135dBm *
```

Channel 1 is at frequency 902.4 MHz, with all subsequent channels in 200 kHz increments. This feature also displays average received signal strength for 12 channels above the 902-928 MHz ISM band. This area of the spectrum is used by paging networks.

When deploying a network, the spectrum analyzer feature is useful for determining which parts of the ISM band may be noisy. This knowledge can be used to select an appropriate hopping pattern, or for creating a custom hopping pattern which avoids those frequencies.

In addition, the presence of extremely high paging noise (> -25dBm) may indicate a need to install Microhard's external cavity filter in line with the antenna. See Chapter 5 for details.

4.4.2 Statistics (ATP)

The ATP <return> command provides a list of several statistics as follows:

```
# of data packets sent = 0
# of data packets received = 0
# of Slave's retries = 0
# of Slave's packets dropped = 0
# of Slave's sync errors = 0
# of CRC errors = 0
OK
```

The MHX-2400 starts the statistics count at zero each time the unit is powered up, or after the ATP command has been issued. By entering the ATP command, all statistics are cleared back to zero. The maximum limit for each statistic is 65535.

4.4.3 Remote Control and Diagnostics (S101=5)

This is a very powerful tool which allows user to remotely configure and interrogate all units in a multipoint system from the Master unit. Simply by having knowledge of the unit address of each slave/repeater in the system, users can set the unit address of the master to match that of the slave/repeater of interest, set S101=5, go online, and interrogate/modify virtually all parameters of the remote repeater/slave unit. It should be noted that when the master goes online, all other units belonging to the network will synchronize with the master, but only the unit whose unit address matches the master's will respond to the master's diagnostic commands.

In addition, in diagnostics mode, the master can change its unit address 'on-the-fly,' avoiding the delays of going into command mode, modifying the unit address, going back online and re-synchronizing with the entire network, before interrogating a new slave/repeater. The master's unit address can be changed while still maintaining synchronization with the entire network, allowing for quick and efficient diagnostic sessions with all remote units. Ensure that register S122=1 on any slave/repeater that you wish to remotely modify.

Table 4 provides a diagnostics command summary. The first column is a list of commands that may be issued at the master. The second column is the corresponding remote register. In general, any command issued without any additional parameters is a read command. For example, if you type:

```
0 <return>
```

The remote slave/repeater will send back the value of its S101 register. On the Master terminal screen, you would see:

```
0    (this is the 0 that you typed, echoed back locally)
3    (this indicates that the remote's S101=3)
```

If you type:

```
04 <return>
```

This command would change the remote's operating mode to S101=4 (repeater). The remote unit should return 'OK'. Remember, if the remote's S122=0 (remote control disabled), the remote will respond with 'ERROR'. In Table 6, Column 1, the meanings of the format is as follows:

COMMAND	A command without (x) indicates that you may not add any additional parameters. i.e., you may only read back the value of the remote's register. You may not modify that register. The only exception to this is the WRITE command 'e'. Type 'e' to force the write command (&W) at the remote modem.
COMMAND(x)	Indicates this command may be sent with or without a parameter. Issuing this command without a parameter reads the corresponding remote's register. Issuing this command with the additional parameter 'x' changes the corresponding remote's register to 'x'. Remember, any changes you wish to retain in the event of a powerdown or reset should be stored to non-volatile memory by issuing the write command 'e'.

Table 6 - Remote Control and Diagnostics

Command	Remote Register	Description
0(x)	S101	Operating Mode
1	S102	Baud Rate
2(x)	S108	Output Power
3(x)	S110	Data Format
4(x)	S115	Repeat Interval
5(x)	S116	Character Timeout
6(x)	S120	RTS/DCD Framing
7(x)	S121	DCD Timeout
8(x)	S117	Modbus Mode
9(x)	S213	Retry Limit
a	test string	Read back 'OK' from remote
a1	test string	Read back 'Microhard Systems, Inc.' from remote
a2	test string	Read back 64 character test string from remote
a3	test string	Read back 255 character test string from remote
b(x)	&E	Framing
c(x)	&C	DCD
d(x)	&K	Handshaking
e	&W	Write
f	S123	RSSI
g(x)	S104	Network Address
h(x)	S106	Hopping Pattern
I(x)	S206	Secondary Hopping Pattern
j(x)	S113	Retransmissions
k1	statistics	Read # of data packets sent
k2	statistics	Read # of data packets received
k3	statistics	Read # of Slave's retries
k4	statistics	Read # of Slave's packets dropped
k5	statistics	Read # of Slave's sync errors
k6	statistics	Read # of CRC errors
k255	statistics	Clear statistics
l(x)	S119	Quick Enter to Command Mode
m(x)	S118	Roaming
n(x)	S114	Packet Size Control
o(x)	S111	Min Packet Size
p(x)	S112	Max Packet Size

5. Installation



The installation, removal or maintenance of all antenna components must be carried out by qualified and experienced professionals.

The installation, removal or maintenance of all antenna components must be carried out by qualified and experienced professionals.

The MHX-2400 complies with FCC part 15 at the modular level for operation in the license-free 902-928 MHz ISM band. This chapter provides guidelines for installing and deploying equipment which incorporates the MHX-2400 module.

5.1 Estimating the Gain Margin

Successful communication between CompactRF modules is dependent on three main factors:

- System Gain
- Path Loss
- Interference

System gain is a calculation in dB describing the performance to be expected between a transmitter-receiver pair. The number can be calculated based on knowledge of the equipment being deployed. The following four factors make up a system gain calculation:

1. Transmitter power (user selectable 0, 10, 20 or 30 dBm)
2. Transmitter gain (transmitting antenna gain minus cabling loss between the transmitting antenna and the MHX-2400 module)
3. Receiver gain (Receiving antenna gain minus cabling loss between the receiving antenna and the module)
4. Receiver sensitivity (Specified as -105 dBm on the MHX-2400 module)

In the following illustration, the transmitting antenna has a gain of 6 dB, and the receiving antenna has a gain of 3 dB. The cable loss between the module and the antenna is 2 dB on both the transmitting and receiving side.

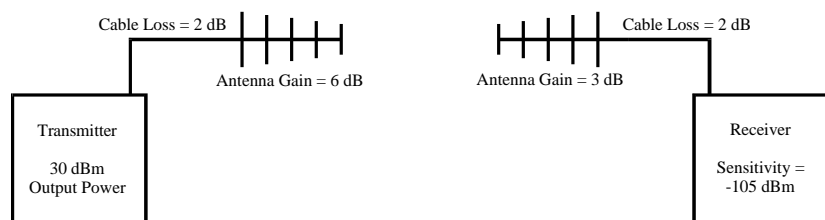

The power level has been set to 30 dBm (1W) on the transmitter, and the receiver sensitivity for the MHX-2400 is -105 dBm.

System gain would be calculated to be:

$$30 - 2 + 6 + 3 - 2 + 105 = 140 \text{ dB.}$$

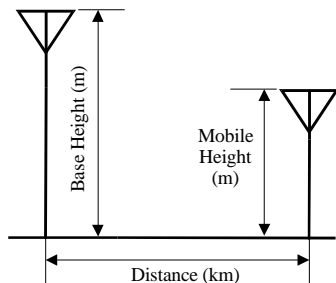

When deploying your system, care must be taken to ensure the **path loss** (reduction of signal strength from transmitter to receiver in dB) between equipment does not exceed the system gain (140 dB in the above example). It is recommended to design for a **gain margin** of at least 10 dB to ensure reliable communication. Gain margin is the difference between system gain and path loss. Referring to the same example, suppose the path loss is 100 dB, the gain margin would be 40 dB, which is more than adequate for reliable communication.

Path loss is a very complicated calculation which mainly depends on the terrain profile, and the height of the antennas off the ground.

The following table provides path loss numbers for varying antenna heights and antenna separation: These numbers are real averages taken from rural environments. They do not apply to urban, non-line-of-sight environments.

Distance (km)	Base Height (m)	Mobile Height (m)	Path Loss (dB)
5	15	2.5	116.5
5	30	2.5	110.9
8	15	2.5	124.1
8	15	5	117.7
8	15	10	105
16	15	2.5	135.3
16	15	5	128.9
16	15	10	116.2
16	30	10	109.6
16	30	5	122.4
16	30	2.5	128.8

Once the equipment is deployed, you can verify the signal strength by entering into Command Mode and reading Register S123. This register provides the average signal strength in dBm. The minimum strength for communication is roughly -105 dBm. For consistent reliable communication, you should try to deploy the equipment such that signal strength exceeds -95 dBm.

5.2 Antennas and Cabling

This section describes the recommended procedure for installing cabling and antennas for use with the MHX-2400 module.

5.2.1 Internal Cabling

The most common method for installing the module is to run a cable from the module's MCX connector to a reverse TNC bulkhead connector on the chassis of the equipment as shown in Figure 11. This cable can be purchased from Microhard Systems.

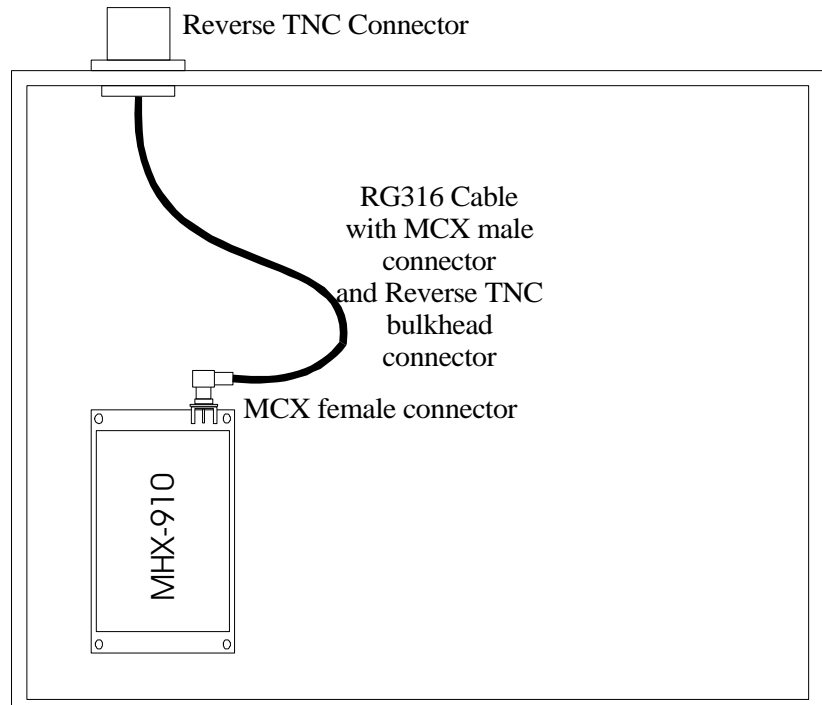

Figure 11. Suggested Internal Cabling

Cable losses are negligible for the short piece used within the chassis. Additional losses up to 0.5 dB may be present in the MCX and Reverse TNC connections.

5.2.2 Installing External Cables, Antennas and Lightning Arrestors

The installation, removal or maintenance of all antenna components must be carried out by qualified and experienced professionals.



The installation, removal or maintenance of all antenna components must be carried out by qualified and experienced professionals.

Never work on an antenna system when there is lightning in the area.



Never work on an antenna system when there is lightning in the area.

Direct human contact with the antenna is potentially unhealthy when the MHX-2400 is generating RF energy. Always ensure that the MHX-2400 equipment is powered down during installation.



Direct human contact with the antenna is potentially unhealthy when the MHX-2400 is generating RF energy. Always ensure that the MHX-2400 equipment is powered down during installation.

Surge Arrestors

The most effective protection against lightning is to install two lightning (surge) arrestors. One at the antenna, and the other at the interface with the equipment. The surge arrestor grounding system should be fully interconnected with the transmission tower and power grounding systems to form a single, fully integrated ground circuit. Typically, both ports on surge arrestors are N-female.

Cabling

The following coax cables are recommended:

Cable	Loss (dB/100ft)
LMR 195	10.7
LMR 400	3.9
LMR 600	2.5

Factors to take into consideration when choosing a cable are:

- price;
- bend radius limitations (the lower performance cables generally can bend more sharply)
- performance requirements; and,
- distance between the equipment and the antenna.

When installing the cable, always begin fastening at the top near the antenna connector/surge arrestor. The cable must be supported at the top with a hose clamp or wrap lock, and at 5 ft intervals down the length of the tower. Over-tightening the fasteners will dent the cable and reduce performance. If properly grounded surge arrestors are not installed at both the top and the bottom of the cable, then the cable should be grounded to the tower at these locations using a cable grounding kit. If the tower is non-conductive, then a separate conductor, physically separate from the cable, should be run down the tower.

Antenna

Before choosing an antenna, you should have some knowledge of the path loss and the topology of the equipment. If the equipment is in a fixed location and is to communicate with only one other unit also in a fixed location, then a Yagi antenna is suitable. Choose a Yagi with enough gain to ensure adequate gain margin. When deploying the Yagi, point the antenna towards the intended target, ensuring the antenna elements are perpendicular to the ground.

If the equipment must communicate with multiple or mobile transceivers, then select an Omni-directional antenna with appropriate gain.

The Effective Radiated Power (ERP) emitted from the antenna cannot exceed +36 dBm ERP.

With the MHX-2400 set to full power, ERP is calculated as follows:

$$\text{ERP} = 30 - (\text{Cabling and Connector Losses}) + (\text{Antenna Gain}) < 36$$

Use the guidelines in the previous section for calculating cable and connector losses. If cabling and connector losses are 2 dB, then the maximum allowable gain of the antenna will be 8 dB.

External Filter

Although the MHX-2400 is capable of filtering out RF noise in most environments, there are circumstances that require external filtering. Paging towers, and cellular base stations in close proximity to the MHX-2400 antenna can desensitize the receiver. Microhard Systems' external cavity filter eliminates this problem. The filter has two N-female ports and should be connected in line at the interface to the RF equipment.

Weatherproofing

Type N and RTNC connectors are not weatherproof. All connectors should be taped with rubber splicing tape (weatherproofing tape), and then coated with a sealant.



To comply with FCC regulations, you must limit ERP to 36 dBm or less.

A. Modem Command Summary

The following provides a command summary for the MHX-2400 module. Factory settings are denoted with a ‘*’.

AT Commands

A	Answer
E	Command Echo E0 No Echo * E1 Command Echo
I	Identification I0 Product Code I2 ROM Checksum test I3 Firmware Version I4 Firmware Date I5 Copyright I6 Firmware Time
O	On-line Mode
Q	Quiet Mode * Q0 Enables Result Codes Q1 Disables Result Codes
V	Result Codes Display V0 Display as Numbers * V1 Display as Words
W	Connection Result * W0 Reports DTE as CONNECT xxxx W1 Reports computer (DTE) rate and wireless rate between modems as CARRIER xxxx. W2 Reports DCE as CONNECT xxxx
Z	Reset and load stored configuration
&C	DCD (Data Carrier Detect) &C0 DCD is always on * &C1 DCD is on when modems are synchronized &C2 DCD used for output data framing
&D	DTR (Data Terminal Ready) &D0 DTR ignored * &D2 DTR disconnects and switches to command &D3 DTR disconnects and resets modem
&F	Load Factory Default &F1 Master &F2 Slave &F3 Repeater &F4 Slave through Repeater
&K	Handshaking &K0 Disable Handshaking &K2 RTS/CTS Input Framing * &K3 Enable Handshaking
&S	DSR (Data Set Ready) &S0 DSR is always on * &S1 DSR on in data, off in command mode
&V	View Configuration
&W	Write configuration to memory
Sxx?	Read S register value
Sxx=yy	Set S register value

Result Codes

0	OK	12	CONNECT 9600
3	NO CARRIER	13	CONNECT 14400
4	ERROR	14	CONNECT 19200
7	CONNECT 2400	15	CONNECT 28800
8	CONNECT 3600	17	CONNECT 38400
9	CONNECT 4800	18	CONNECT 57600
10	CONNECT 7200	33	CONNECT 115200
64	CARRIER 20000	62	CARRIER 45000

S Registers

S0	Auto Answer [0...255] 0 = power up in Command Mode, non-zero = power up in Data Mode
S2	Escape code [0...255] default ‘+’
S3	CR character [0...255] default <cr>
S4	Line Feed [0...255] default <lf>
S5	Backspace [0...255] default <bs>
S101	Operating Mode 1 - Master Point to Multipoint 2 - Master Point to Point 3 - Slave 4 - Repeater
S102	Serial Baud Rate *1 = 115200, 2 = 57600, 3 = 38400 4 = 28800, 5 = 19200, 6 = 14400 7 = 9600, 8 = 7200, 9 = 4800, 10 = 3600, 11 = 2400
S103	Wireless Link Rate 2 = Fast w/o FEC *4 = Fast with FEC
S104	Network Address [0...65535]
S105	Unit Address [1...65535]
S106	Primary Hopping Pattern [0...50]
S206	Secondary Hopping Pattern [0...50]
S107	Encryption Key [0...65535]
S108	Output Power Level 0 = 10 mW, 1 = 50 mW, *2 = 100 mW, 3 = 250 mW 4 = 500 mW, 5 = 750 mW, 6 = 1W
S109	Hopping Interval 1 = 8 msec, 2 = 12 msec, 3 = 16 msec, 4 = 20 msec, 5 = 30 msec, 6 = 45 msec, 7 = 80 msec, *8 = 120 msec
S110	Data Format * 1 = 8N1, 2 = 8N2, 3 = 8E1, 4 = 8O1 5 = 7N1, 6 = 7N2, 7 = 7E1, 8 = 7O1 9 = 7E2, 10 = 7O2, 11 = 9N1
S111	Packet Minimum Size [1...Maximum Size]
S112	Packet Maximum Size [2...255]
S113	Packet Retransmissions [0...255]
S213	Packet Retry Limit [0...255]
S115	Packet Repeat Interval [1..255] Default = 1
S116	Packet Character Timeout [0...254 ms]
S117	Modbus Mode *0 = Disabled, 1 = Enabled
S120	RTS/DCD Framing Interval [0...254 ms]
S121	DCD Timeout [0...254 ms]

B. Serial Interface

The MHX-2400 module uses 8 pins on the header connector for asynchronous serial I/O. The interface conforms to standard RS-232 signals without level shifting, so direct connection to a host microprocessor is possible.

The signals in the asynchronous serial interface are described below:

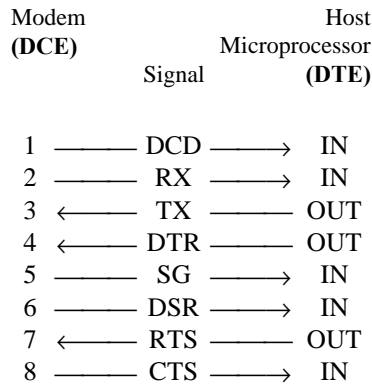

Arrows denote the direction that signals are asserted (e.g., DCD originates at the DCE and tells the DTE that a carrier is present).

DCD *Data Carrier Detect* - **Output from Modem** - When asserted (TTL low), DCD informs the DTE that a communications link has been established with another MHX-2400.

RX *Receive Data* - **Output from Modem** - Signals transferred from the MHX-2400 are received by the DTE via RX.

TX *Transmit Data* - **Input to Modem** - Signals are transmitted from the DTE via TX to the MHX-2400.

DTR *Data Terminal Ready* - **Input to Modem** - Asserted (TTL low) by the DTE to inform the modem that it is alive and ready for communications.

SG *Signal Ground* - Provides a ground reference for all signals transmitted by both DTE and DCE.

DSR *Data Set Ready* - **Output from Modem** - Asserted (TTL low) by the DCE to inform the DTE that it is alive and ready for communications. DSR is the modem's equivalent of the DTR signal.

RTS *Request to Send* - **Input to Modem** - A "handshaking" signal which is asserted by the DTE (TTL low) when it is ready. When hardware handshaking is used, the RTS signal indicates to the DCE that the host can receive data.

CTS *Clear to Send* - **Output from Modem** - A "handshaking" signal which is asserted by the DCE (TTL low) when it has enabled communications and transmission from the DTE can commence. When hardware handshaking is used, the CTS signal indicates to the host that the DCE can receive data.

Notes: It is typical to refer to RX and TX from the perspective of the DTE. This should be kept in mind when looking at signals relative to the modem (DCE); the modem *transmits* data on the RX line, and *receives* on TX.

"DCE" and "modem" are often synonymous since a modem is typically a DCE device.

"DTE" is, in most applications, a device such as a host microprocessor.

C. Sample Schematic Diagram

The following is a sample microprocessor implementation with a MICROCHIP PIC 16C74 and the MHX-2400. The MHX-2400 performs no level shifting on the serial port, so direct connection to the host microprocessor is possible.

DO NOT CONNECT THE MHX-2400 TO RS 232 DRIVER OUTPUTS. DAMAGE TO THE UNIT MAY RESULT.

On this implementation, the onboard SCI of the PIC 16C74 is directly connected pins 2 and 3 of the MHX-2400. The bi-directional Port D is used for asserting or monitoring control signals from the MHX-2400.

The RESET signal is momentary active low signal asserted by the host microprocessor.

RESET initializes the MHX-2400 and places the system in a known state. This signal should be set high after the host microprocessor has been reset.

The CONFIG line is reserved for factory use. This signal should be set high.

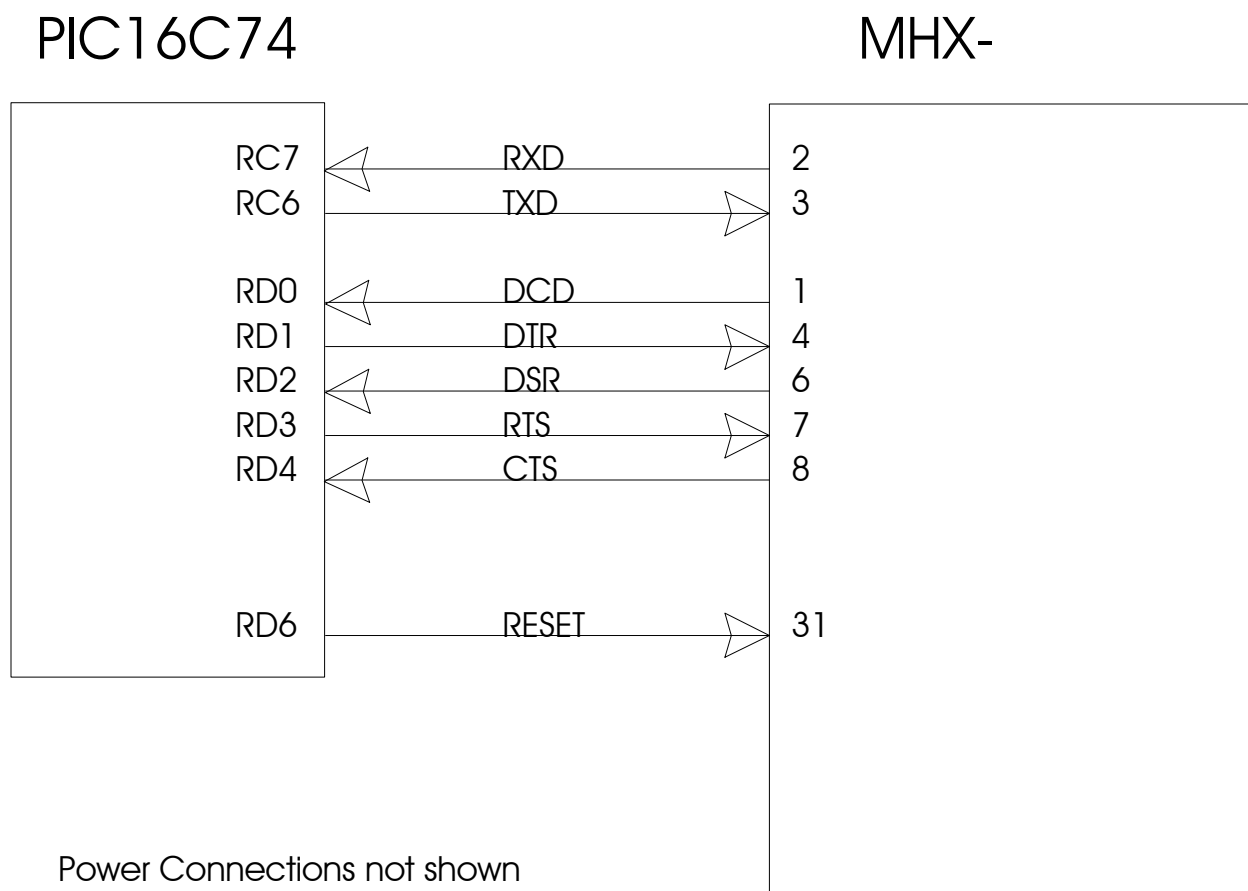

D. Factory Default Settings

AT&F1 - Master Default Settings

E1, Q0, V1, W0, S0=0, S2=43, S3=13, S4=10, S5=8

DCD	&C1 (On)
DTR	&D0 (DTR is ignored)
Framing	&E0 (Disabled)
Handshaking	&K3 (Enabled)
DSR	&S1 (On in Data, Off in Command)
Operating Mode	S101=1 (Master P-MP)
Serial Baud Rate	S102=1 (115kbaud)
Wireless Link Rate	S103=4 (Fast, FEC)
Network Address	S104=1
Unit Address	S105=1
Primary Hop Pattern	S106=0
Encryption Key	S107=1
Output Power	S108=2 (100mW)
Hop Interval	S109=8
Data Format	S110=1 (8N1)
Packet Minimum Size	S111=1
Packet Maximum Size	S112=255
Packet Retransmissions	S113=2
Packet Repeat Interval	S115=1 (Don't Care)
Character Timeout (ms)	S116=8
Modbus Mode	S117=0
RTS/DCD Framing (ms)	S120=0
DCD Timeout (ms)	S121=0
Secondary Hop Pattern	S206=2 (Don't Care)
Packet Retry Limit	S213=2 (Don't Care)

AT&F2 - Slave Default Settings

E1, Q0, V1, W0, S0=1, S2=43, S3=13, S4=10, S5=8

DCD	&C1 (On when modems are synced)
DTR	&D0 (DTR is ignored)
Framing	&E0 (Disabled)
Handshaking	&K3 (Enabled)
DSR	&S1 (On in Data, Off in Command)
Operating Mode	S101=3 (Slave)
Serial Baud Rate	S102=1 (115kbaud)
Wireless Link Rate	S103=4 (Fast, FEC) (Set by Master)
Network Address	S104=1
Unit Address	S105=2
Primary Hop Pattern	S106=0
Encryption Key	S107=1
Output Power	S108=2 (100mW)
Hop Interval	S109=8 (Set by Master)
Data Format	S110=1 (8N1)
Packet Minimum Size	S111=1 (Set by Master)
Packet Maximum Size	S112=255 (Set by Master)
Packet Retransmissions	S113=2 (Don't Care)
Packet Repeat Interval	S115=1
Character Timeout (ms)	S116=9
Modbus Mode	S117=0
RTS/DCD Framing (ms)	S120=0
DCD Timeout (ms)	S121=0
Secondary Hop Pattern	S206=2 (Don't Care)
Packet Retry Limit	S213=2

AT&F3 - Repeater Default Settings

E1, Q0, V1, W0, S0=1, S2=43, S3=13, S4=10, S5=8

DCD	&C1 (On when modems are synced)
DTR	&D0 (DTR is ignored)
Framing	&E0 (Disabled)
Handshaking	&K3 (Enabled)
DSR	&S1 (On in Data, Off in Command)
Operating Mode	S101=4 (Repeater)
Serial Baud Rate	S102=1 (115kbaud)
Wireless Link Rate	S103=4 (Fast, FEC) (Set by Master)
Network Address	S104=1
Unit Address	S105=3
Primary Hop Pattern	S106=0
Encryption Key	S107=1
Output Power	S108=2 (100mW)
Hop Interval	S109=8 (Set by Master)
Data Format	S110=1 (8N1)
Packet Minimum Size	S111=1 (Set by Master)
Packet Maximum Size	S112=255 (Set by Master)
Packet Retransmissions	S113=2
Packet Repeat Interval	S115=1
Character Timeout (ms)	S116=8
Modbus Mode	S117=0
RTS/DCD Framing (ms)	S120=0
DCD Timeout (ms)	S121=0
Secondary Hop Pattern	S206=2
Packet Retry Limit	S213=2

AT&F4 - Slave Through Repeater Default Settings

E1, Q0, V1, W0, S0=1, S2=43, S3=13, S4=10, S5=8

DCD	&C1 (On when modems are synced)
DTR	&D0 (DTR is ignored)
Framing	&E0 (Disabled)
Handshaking	&K3 (Enabled)
DSR	&S1 (On in Data, Off in Command)
Operating Mode	S101=3 (Slave)
Serial Baud Rate	S102=1 (115kbaud)
Wireless Link Rate	S103=4 (Fast, FEC) (Set by Master)
Network Address	S104=1
Unit Address	S105=4
Primary Hop Pattern	S106=2
Encryption Key	S107=1
Output Power	S108=2 (100mW)
Hop Interval	S109=8 (Set by Master)
Data Format	S110=1 (8N1)
Packet Minimum Size	S111=1 (Set by Master)
Packet Maximum Size	S112=255 (Set by Master)
Packet Retransmissions	S113=2 (Don't Care)
Packet Repeat Interval	S115=1
Character Timeout (ms)	S116=8
Modbus Mode	S117=0
RTS/DCD Framing (ms)	S120=0
DCD Timeout (ms)	S121=0
Secondary Hop Pattern	S206=2 (Don't Care)
Packet Retry Limit	S213=2

E. Performance Tables

The scope of this appendix is to find the best possible performance and maximum packet size at different modes of operation. The setup assumes a baud rate of 115k, no retries and no retransmissions..

	Hop Interval	Optimal Packet Size (bytes)	Throughput (kbps)*
Slave to Master Communication. (No Repeater) Link Rate = Fast NO FEC	1 (8 ms)	14	20
	2 (12 ms)	66	52
	3 (16 ms)	110	66
	4 (20 ms)	154	74
	5 (30 ms)	255	83
	6 (45 ms)	255	56
	7 (80 ms)	255	31
	8 (120 ms)	255	21
Slave to Master Communication. (No Repeater) Link Rate = Fast WITH FEC	1 (8 ms)	5	4
	2 (12 ms)	34	22
	3 (16 ms)	54	28
	4 (20 ms)	76	32
	5 (30 ms)	130	38
	6 (45 ms)	210	43
	7 (80 ms)	255	30
	8 (120 ms)	255	20
Repeater to Master Direct Communication. Link Rate = Fast NO FEC	1 (8 ms)	N/A	N/A
	2 (12 ms)	3	1
	3 (16 ms)	22	13
	4 (20 ms)	44	21
	5 (30 ms)	101	32
	6 (45 ms)	178	39
	7 (80 ms)	255	31
	8 (120 ms)	255	21
Repeater to Master Direct Communication. Link Rate = Fast WITH FEC	1 (8 ms)	N/A	N/A
	2 (12 ms)	N/A	N/A
	3 (16 ms)	5	2
	4 (20 ms)	16	6
	5 (30 ms)	43	12
	6 (45 ms)	80	16
	7 (80 ms)	174	20
	8 (120 ms)	255	20
Slave to Master Through One or More Repeaters. Link Rate = Fast NO FEC	1 (8 ms)	N/A	N/A
	2 (12 ms)	3	1
	3 (16 ms)	22	13
	4 (20 ms)	43	21
	5 (30 ms)	93	31
	6 (45 ms)	174	38
	7 (80 ms)	255	31
	8 (120 ms)	255	21
Slave to Master Through One or More Repeaters. Link Rate = Fast WITH FEC	1 (8 ms)	N/A	N/A
	2 (12 ms)	N/A	N/A
	3 (16 ms)	N/A	N/A
	4 (20 ms)	14	6
	5 (30 ms)	40	12
	6 (45 ms)	80	16
	7 (80 ms)	174	19
	8 (120 ms)	255	20

F. Hopping Patterns

This Appendix provides a guide for selecting appropriate hopping patterns (S106,S206). There are 49 hopping patterns: Patterns have been designed to notch out certain segments of the ISM band.

Pattern Number	Spectrum Used
0 - 7	2.4012 - 2.4824 GHz
8 - 10	2.4012 - 2.4312 GHz
11 - 13	2.4052 - 2.4352 GHz
14 - 16	2.4092 - 2.4392 GHz
17 - 19	2.4132 - 2.4432 GHz
20 - 22	2.4172 - 2.4472 GHz
23 - 25	2.4212 - 2.4512 GHz
26 - 28	2.4252 - 2.4552 GHz
29 - 31	2.4292 - 2.4592 GHz
32 - 34	2.4332 - 2.4632 GHz
35 - 37	2.4372 - 2.4672 GHz
38 - 40	2.4412 - 2.4712 GHz
41 - 43	2.4452 - 2.4752 GHz
44 - 46	2.4492 - 2.4792 GHz
47 - 48	2.4520 - 2.4820 GHz

Patterns 44 to 48 may be manually edited by entering AT&H at the Command Line. Each pattern must use a channel only once, and must consist of exactly 76 channels. There are 202 channels available ranging from Channel 1 at 2.4016 GHz up to Channel 202 at 2.4820 GHz

G. Technical Specifications

Electrical/Physical

Data Interface	Asynchronous Serial Port, TTL Levels
Signals	Sig. Gnd, TX, RX, DCD, DSR, DTR, RTS, CTS
Bandwidth / Data Rate	2,400 - 115,200 bps, uncompressed half-duplex, Approx. 100 kbps sustained in intelligent asymmetrical full-duplex transmission mode
Communications Range ¹	30 kilometres (19 miles)
Power Requirements	5 VDC, 1.0 Amp
Power Consumption	700 mA max, 450 mA typical at 1W transmit; 200 mA receive
Operating Frequency	2.4000 GHz to 2.4835 GHz
System Gain	135 dB
Sensitivity	-105 dBm
Output Power	10, 50, 100, 250, 500, 750, 1000mW (user-selectable)
Spreading Code	Frequency Hopping
Hopping Patterns	20 pseudo-random, user-selectable
Error Detection	CRC-16 with auto re-transmit
Error Correction	User-selectable Forward Error Correction (FEC)
Dimensions (LxWxH)	Encl: 3.5" x 2.1" x 1." (90 mm x 53 mm x 25 mm)
Weight	75 grams
Operating Environment	Temperature: -40 to +70°C Humidity: 5 to 95%, non-condensing
Storage Temperature	-40 to 90°C

1. Clear line-of-sight, elevated high-gain antennas.

H. Glossary

Terminology Used in the MHX-2400 Operating Manual

Asynchronous communications A method of telecommunications in which units of single bytes of data are sent separately and at an arbitrary time (not periodically or referenced to a clock). Bytes are “padded” with start and stop bits to distinguish each as a unit for the receiving end, which need not be synchronized with the sending terminal.

Attenuation The loss of signal power through equipment, lines/cables, or other transmission devices. Measured in decibels (dB).

Bandwidth The information-carrying capacity of a data transmission medium or device, usually expressed in bits/second (bps).

Baud Unit of signaling speed equivalent to the number of discrete conditions or events per second. If each signal event represents only one bit condition, then baud rate equals bits per second (bps) – this is generally true of the serial data port, so *baud* and *bps* have been used interchangeably in this manual when referring to the serial port; this is not always the case during the DCE-to-DCE communications, where a number of modulation techniques are used to increase the bps rate over the baud rate.

Bit The smallest unit of information in a binary system, represented by either a 1 or 0. Abbreviated “b”.

Bits per second (b/s or bps) A measure of data transmission rate in serial communications. Also see *baud*.

Byte A group of bits, generally 8 bits in length. A byte typically represents a character of data. Abbreviated “B”.

Characters per second (cps) A measure of data transmission rate for common exchanges of data. A character is usually represented by 10 bits: an 8-bit byte plus two additional bits for marking the start and stop. Thus, in most cases (but not always), *cps* is related to *bits per second (bps)* by a 1:10 ratio.

CRC (Cyclic Redundancy Check) An error-detection scheme for transmitted data. Performed by using a polynomial algorithm on data, and appending a checksum to the end of the packet. At the

receiving end, a similar algorithm is performed and checked against the transmitted checksum.

Crossover cable (Also known as rolover, null-modem, or modem-eliminator cable) A cable which allows direct DTE-to-DTE connection without intermediate DCEs typically used to bridge the two communicating devices. Can also be used to make cabled DCE-to-DCE connections. The name is derived from “crossing” or “rolling” several lines, including the TX and RX lines so that transmitted data from one DTE is received on the RX pin of the other DTE and vice-versa.

Data Communications Equipment (DCE, also referred to as Data Circuit-Terminating Equipment, Data Set) A device which facilitates a communications connection between *Data Terminal Equipment* (DTEs). Often, two or more compatible DCE devices are used to “bridge” DTEs which need to exchange data. A DCE performs signal encoding, decoding, and conversion of data sent/received by the DTE, and transmits/receives data with another DCE. Common example is a modem.

Data Terminal Equipment (DTE) An end-device which sends/receives data to/from a DCE, often providing a user-interface for information exchange. Common examples are computers, terminals, and printers.

dBm Stands for “Decibels referenced to one milliwatt (1 mW)”. A standard unit of power level commonly used in RF and communications work. n dBm is equal to $10^{(n/10)}$ milliwatt, so 0dBm = 1mW, -10dBm = 0.1mW, -20dBm = 0.01mW, etc.

DCE See *Data Communications Equipment*.

DTE See *Data Terminal Equipment*.

Flow Control A method of moderating the transmission of data so that all devices within the communications link (DTEs and DCEs) transmit and receive only as much data as they can handle at once. This prevents devices from sending data which cannot be received at the other end due to conditions such as a full buffer or hardware not in a ready state. This is ideally handled by hardware using flow-control and handshaking signals, but

can be controlled also by software using X-ON/X-OFF (transmitter on/off) commands.

Frequency-hopping A type of *spread spectrum* communication whereby the carrier frequency used between transmitter and receiver changes repeatedly in a synchronized fashion according to a specified algorithm or table. This minimizes unauthorized jamming (interference) and interception of telecommunications.

Full-duplex Where data can be transmitted, simultaneously and independently, bi-directionally.

Half duplex Exists when the communications medium supports bi-directional transmission, but data can only travel in one direction at the same time.

Handshaking A flow-control procedure for establishing data communications whereby devices indicate that data is to be sent and await appropriate signals that allow them to proceed.

Line-of-sight Condition in which a transmitted signal can reach its destination by travelling a straight path, without being absorbed and/or bounced by objects in its path.

Master The station which controls and/or polls one or more Slave stations in a point-to-point or point-to-multipoint network. Often functions as a server or hub for the network.

Non-volatile memory Memory which retains information which is written to it.

Null modem cable See *Crossover cable*.

Point-to-point A simple communications network in which only two DTEs are participants.

Point-to-multipoint A communications network in which a *Master* DTE communicates with two or more *Slave* DTEs.

Repeater A device which automatically amplifies or restores signals to compensate for distortion and/or attenuation prior to retransmission. A repeater is typically used to extend the distance for which data can be reliably transmitted using a particular medium or communications device.

RS-232 (Recommended Standard 232; more accurately, RS-232C or EIA/TIA-232E) Defined by the EIA, a widely known standard electrical and physical interface for linking DCEs and DTEs for serial data communications. Traditionally specifies a 25-pin D-sub connector, although many newer devices use a compact 9-pin connector with only the essential signaling lines used in asynchronous serial communications.

Lines have two possible states: “high” (on, active, asserted, carrying +3 to +25 V) or “low” (off, inactive, disasserted, carrying -3 to -25 V).

RTU (Remote Terminal Unit) A common term describing a DTE device which is part of a wide-area network. Often a RTU performs data I/O and transmits the data to a centralized station.

Serial communications A common mode of data transmission whereby character bits are sent sequentially, one at a time, using the same signaling line. Contrast with parallel communications where all bits of a byte are transmitted at once, usually requiring a signal line for each bit.

Shielded cable Interface medium which is internally shrouded by a protective sheath to minimize external electromagnetic interference (“noise”).

Slave A station which is controlled and/or polled by the Master station for communications. Typically represents one end of a point-to-point connection, or one of the terminal nodes in a point-to-multipoint network. Often a RTU is linked by a Slave DCE.

Spread spectrum A method of transmitting a signal over a wider bandwidth (using several frequencies) than the minimum necessary for the originally narrowband signal. A number of techniques are used to achieve spread spectrum telecommunications, including *frequency hopping*. Spread spectrum provides the possibility of sharing the same band amongst many users while increasing the tolerance to interference and noise, and enhancing privacy of communications.

Throughput A measure of the rate of data transmission passing through a data communication system, often expressed as bits or characters per second (bps or cps).

I. FCC RF Exposure

FCC RF Exposure Warning

In order to comply with the FCC/IC adopted RF exposure requirements, this transmitter system will be installed by the manufacturer's reseller professional. Installation of all antennas must be performed in a manner that will provide at least 20 cm clearance from the front radiating aperture, to any user or member of the public.